



This is a digital copy of a book that was preserved for generations on library shelves before it was carefully scanned by Google as part of a project to make the world's books discoverable online.

It has survived long enough for the copyright to expire and the book to enter the public domain. A public domain book is one that was never subject to copyright or whose legal copyright term has expired. Whether a book is in the public domain may vary country to country. Public domain books are our gateways to the past, representing a wealth of history, culture and knowledge that's often difficult to discover.

Marks, notations and other marginalia present in the original volume will appear in this file - a reminder of this book's long journey from the publisher to a library and finally to you.

### **Usage guidelines**

Google is proud to partner with libraries to digitize public domain materials and make them widely accessible. Public domain books belong to the public and we are merely their custodians. Nevertheless, this work is expensive, so in order to keep providing this resource, we have taken steps to prevent abuse by commercial parties, including placing technical restrictions on automated querying.

We also ask that you:

- + *Make non-commercial use of the files* We designed Google Book Search for use by individuals, and we request that you use these files for personal, non-commercial purposes.
- + *Refrain from automated querying* Do not send automated queries of any sort to Google's system: If you are conducting research on machine translation, optical character recognition or other areas where access to a large amount of text is helpful, please contact us. We encourage the use of public domain materials for these purposes and may be able to help.
- + *Maintain attribution* The Google "watermark" you see on each file is essential for informing people about this project and helping them find additional materials through Google Book Search. Please do not remove it.
- + *Keep it legal* Whatever your use, remember that you are responsible for ensuring that what you are doing is legal. Do not assume that just because we believe a book is in the public domain for users in the United States, that the work is also in the public domain for users in other countries. Whether a book is still in copyright varies from country to country, and we can't offer guidance on whether any specific use of any specific book is allowed. Please do not assume that a book's appearance in Google Book Search means it can be used in any manner anywhere in the world. Copyright infringement liability can be quite severe.

### **About Google Book Search**

Google's mission is to organize the world's information and to make it universally accessible and useful. Google Book Search helps readers discover the world's books while helping authors and publishers reach new audiences. You can search through the full text of this book on the web at <http://books.google.com/>

KQ-580

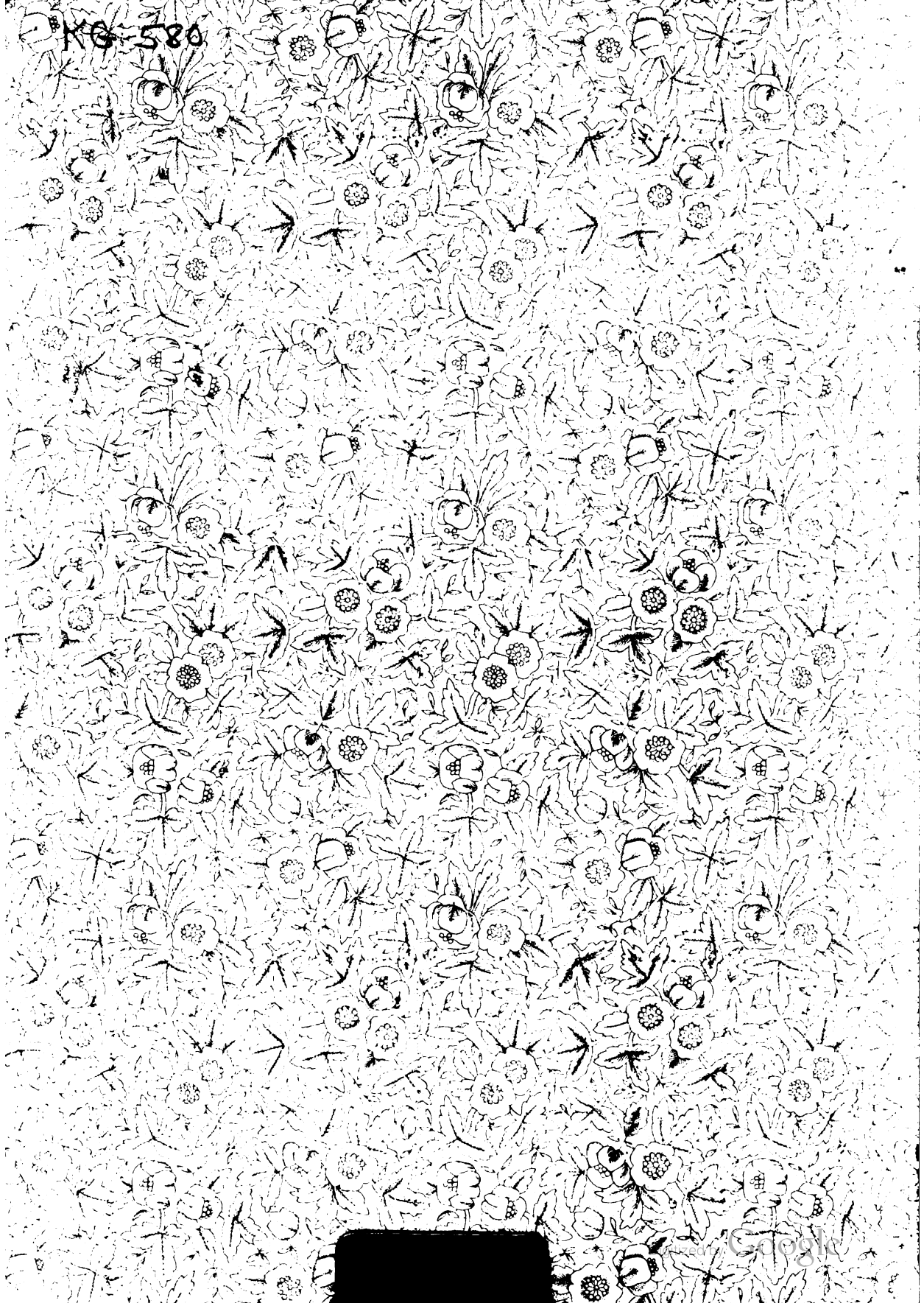









THE  
ENCYCLOPÆDIA BRITANNICA

A

DICTIONARY

OF

ARTS, SCIENCES, AND GENERAL LITERATURE

**Ninth Edition—Popular Reprint**

*VOLUME III.*

NEW YORK  
HENRY G. ALLEN AND COMPANY  
PUBLISHERS

1888.

KG 580



---

ARGYLE PRESS,  
PRINTING AND BOOKBINDING  
24 & 26 WOOSTER ST., N. Y.

---



# Encyclopædia Britannica.—VOL. III.

## PRINCIPAL CONTENTS.

- ATHENS.** Rev. EDWARD L. HICKS, M.A., Fellow of Corpus Christi College, Oxford.  
**ATHLETIC SPORTS.** H. F. WILKINSON, one of the Editors of "The Field."  
**ATLANTIC.** WILLIAM B. CARPENTER, M.D., C.B., LL.D., F.R.S.  
**ATMOSPHERE.** ALEX. BUCHAN, Secretary of the Meteorological Society of Scotland.  
**ATOM.** J. CLERK MAXWELL, D.C.L., F.R.S., Professor of Experimental Physics, University of Cambridge.  
**ATTICA.** Rev. HENRY F. TOZER, M.A., F.R.G.S., Author of "Geography of Greece."  
**ATTRACTION.** Prof. G. CLERK MAXWELL.  
**AUGUSTAN HISTORY.** RICHARD GARNETT, British Museum.  
**AUGUSTINE.** Very Rev. Principal TULLOCH.  
**AUGUSTUS.** Very Rev. CHARLES MERRIVALE, LL.D., D.D., Dean of Ely.  
**AUSTRALIA.** R. ACTON.  
**AUSTRIA.** DAVID KAY, F.R.G.S.  
**AXIOM.** G. CROOM ROBERTSON, Professor of Logic, University College, London.  
**BABYLONIA.** Rev. A. H. SAYCE, M.A., Fellow and Tutor of Queens College, Oxford.  
**BACON.** ROBERT ADAMSON, M.A., Professor of Political Economy, Owens College, Manchester.  
**BAGHDAD.** Sir HENRY C. RAWLINSON, K.C.B., D.C.L., late President of Royal Geographical Society.  
**BAKING.** JAMES PATON, Kelvingrove Industrial Museum, Glasgow.  
**BALANCE.** WILLIAM DITTMAR, M.D., Professor of Chemistry, Andersonian University, Glasgow.  
**BALANCE OF POWER.** HENRY REEVE, C.B., Clerk to H.M. Privy Council.  
**BALLADS.** ANDREW LANG.  
**BALLOT.** W. C. SMITH, LL.B., Advocate.  
**BALTIC.** Dr CARPENTER, C.B.  
**BANKING.** LEONARD H. COURTNEY, M.P.  
**BANKRUPTCY.** EDMUND ROBERTSON, Professor of Roman Law, University College, London.  
(AMERICAN LAW) J. LOWELL.  
**BAPTISM.** Prof. T. M. LINDSAY, D.D.  
**BAPTISTS.** Rev. F. W. GOTCH, LL.D.  
**BARBADOS.** J. L. OHLSON, Secretary to West India Committee, London.  
**BAROMETER.** ALEX. BUCHAN, F.R.S.E.  
**BARRACKS.** Col. CHAS. B. EWART, C.B., Deputy Director of Works for Barracks.  
**BASILICA.** Rev. Canon VENABLES.  
**BATHS.** Dr JOHN MACPHERSON, Author of "Baths and Wells of Europe."  
**BATTLE.** Col. CHARLES CHENEY, R.E.  
**BEARD.** JOHN DORAN, Ph.D., late Editor of "Notes and Queries."  
**BEAUMONT AND FLETCHER.** ALGERNON CHARLES SWINBURNE.  
**BECHWANA.** Rev. Dr MOFFAT.  
**BEE.** JOHN HUNTER, late Hon. Secretary British Bee-Keeper's Association.  
**BEETHOVEN.** F. HUEFFER, Author of "Wagner and the Music of the Future."  
**BELGIUM.** DAVID KAY, F.R.G.S.  
**BELL.** Rev. H. E. HAWES, M.A., Author of "Music and Morals."  
**BELLINI.** Prof. SIDNEY COLVIN, University of Cambridge.  
**BELLOWS.** A. B. MACDOWALL, London.  
**BENGAL.** W. W. HUNTER, LL.D., Statistician to Government of India.  
**BENTHAM.** T. E. HOLLAND, M.A., B.C.L., Chichele Professor of International Law, Oxford.  
**BENTLEY.** Rev. MARK PATTISON, Rector of Lincoln College, Oxford, Author of "Isaac Casaubon, 1659-1616"  
**BERKELEY.** Prof. ROBERT ADAMSON, Owens College, Manchester  
**BERLIN.** Rev. G. P. DAVIES.  
**BEZIQUE.** HENRY JONES ("CAVENDISH").  
**BIBLE.** Prof. W. ROBERTSON SMITH, Free Church College, Aberdeen, etc.  
**BIBLIOGRAPHY.** E. FAIRFAX TAYLOR.  
**BILLIARDS.** G. F. PARDON ("Capt. CRAWLEY").  
**BIOLOGY.** Prof. HUXLEY and W. T. THISTLETON DYER, M.A.  
**BIRDS.** Prof. W. K. PARKER, Royal College of Surgeons, London; and Prof. ALFRED NEWTON, Cambridge.  
**BIRMINGHAM.** J. T. BUNCE, Editor "Birmingham Daily Post."  
**BISHOP.** Sir TRAVERS TWISS, Q.C.  
**BISMUTH.** H. BAUERMAN, Fellow of the Geological Society.  
**BLACK SEA.** Dr CARPENTER, C.B.  
**BLEACHING.** JAMES PATON, Kelvingrove Industrial Museum, Glasgow.  
**BLIND.** F. J. CAMPBELL.  
**BLOCK MACHINERY.** THOMAS MORLEY, F.I.N.A.  
**BLOW PIPE.** A. B. MACDOWALL.  
**BOCCACCIO.** F. HUEFFER, Author of "Wagner and the Music of the Future."  
**BOETIUS.** JAMES DONALDSON, LL.D., Author of "Early Christian Literature."



# ENCYCLOPÆDIA BRITANNICA.

## A T H E N S

**A**THENS. (Ἀθήναι, ΑΘΗΝΑΙ) was the name of as many as nine towns in various parts of the Grecian world, among which *Athens Diades*, in the N.W. of Eubœa, a town belonging to the Athenian confederation, is worthy of mention. But it was the capital of Attica which invested the name of Athens with an undying charm for the poet, the artist, the philosopher, the historian, for all time. It is situated in long 23° 44' E., lat. 37° 58' N., towards the south of the central plain (πεδῖον) of Attica, about 4½ miles from the harbour of Piræus, and nearly 4 from the Bay of Phalerum. The survey of Pausanias (i. 2-30), when compared with existing remains, and supplemented by the numerous incidental notices of ancient authors, enables us to form a more perfect conception of the topography of ancient Athens than of any other Greek city. Recent excavations have added greatly to our knowledge of it, and the literature of the subject is very extensive (see p. 11, *infra*). Our object in this article will be to treat of the topography of Athens from an historical point of view, and to show how the rise, the greatness, the decline of the city may be read in the history of its buildings.

There seems little reason to doubt that the earliest settlement on Athenian soil was upon the cliff afterwards famous as the Acropolis. Such is the express statement of Thucydides (ii. 15), who observes that the Acropolis was commonly termed at Athens ἡ πόλις, much as the oldest part of London is styled "The City." The earliest inhabitants appear to have been Pelasgians; and though it was the boast of the Athenians that they alone of all Greek states were indigenous (*αὐτόχθονες*), yet their town would from the first have received accessions from various parts of the continent, the peaceful poverty of Attica affording a welcome refuge in those early and unsettled times (Thucyd., i. 2). The most accessible portion of the Acropolis is the western side, where it is joined by a neck of hill to the Areopagus. On this side there existed down to later times the remains of fortifications built by the earliest inhabitants, with nine doorways, one within the other, called τὸ Πιλοσυκίον, or τὸ Ἐννεύρωλον. This fort protected the only entrance to the citadel, which was surrounded by a wall, and artificially levelled for the reception of buildings. Within this fortified enclosure stood the shrine of Athena Polias (Homer, *Iliad*, ii. 449; *Odyssey*,

vii. 81), afterwards known as the Erechtheum,—and an altar of Zeus Polieus, where the strange sacrifices of the Dipolis were celebrated. A Prytaneum, containing the hearth-fire of the state, and serving as the residence of the king, would be another indispensable feature in the primitive town. But while the king and some of the most sacred families probably had dwellings within the fortress itself, Thucydides (ii. 15) points out that a great part of the early population dwelt outside its walls, under the south side of the cliff, probably without fortification, but retiring to the citadel in times of peril. In this quarter, towards the Ilissus, stood the oldest Athenian sanctuary of Dionysus, in a region called *Alveai*, from having been literally a marsh in early times. Not far off, and nearer the stream, stood the temple of Zeus Olympius, said to be founded by Deucalion (Pausan., i. 18), of which more will be said presently, the precinct of Gæa Olympia, and other sacred places. Here also was the fountain of Callirrhoe, afterwards ornamented by the Pisistratids, and called Enneacrunus, the water of which was sought for sacred purposes long after the city had outgrown these early limits (Thucyd., ii. 15). The region we have been describing formed the nucleus of the later city, and therefore, at the subdivision of all Attica into demes, this quarter was distinguished by the name *Κυδαθηναίων*.

To the west of the Acropolis there extends from N. to S. a range of hills, the three most prominent heights of which are commonly known respectively as the Hill of the Nymphs, the Pnyx, and the Museum,—the Nymphs' Hill being separated from the Acropolis by the Areopagus, which intervenes between. Everywhere upon the slopes of the hills just mentioned traces have lately been discovered of ancient dwellings hewn out of the solid rock. But while all these rock-dwellings are extremely ancient, yet some appear less primitive than others; it is remarked that those which exist on the Areopagus and on the hill-sides nearest to the Acropolis are of a smaller and ruder type, those more distant from the citadel being somewhat more convenient in plan and extent. Legend declares the Athenians to have originally dwelt in rock-hewn caves (Dyer's *Athens*, ch. i.), and it would seem that primitive Athens gradually extended itself from the Acropolis in this W. and S.W. direction. This quarter was afterwards

known as the intramural deme of Melite, a name derived, perhaps, from the balm which then grew there (the *κόσμος μελίτεια* of Theocr., iv. 25).<sup>1</sup> The historian E. Curtius (*Attische Studien*, pt. i.) has, indeed, gone so far as to regard these rock-dwellings as earlier than the occupation of the Acropolis itself. But the contrary opinion of Thucydides is worth something, and the natural strength of the Acropolis would make it the most obvious spot for primitive occupation. Accordingly, we shall not be giving too free a licence to our imagination if we conceive of primitive Athens as a twofold settlement, partly on the Acropolis and the low ground at its southern foot, and partly upon the eastern slopes of the hills on the west. It may even have been the consolidation of these two villages into one township that gave rise to the legend ascribing to Theseus the *ενοικισμός* or consolidation of Attica. It would be natural for legend to assign to one definite time, and connect with one great mythical name, that process of unification which probably was as gradual as it was spontaneous. As the population of the early town continued to increase, two more districts seem to have been incorporated—Collytus, extending from the east of Melite, between the Acropolis and Areopagus, and Cerameicus, or the "Potters' quarter" ("Tuileries"), which extended from the same two hills towards the north and north-west. The regions we have now described appear to have made up the Athens of Solonian times. The earliest historical event which illustrates Athenian topography is the rising of Cylon (Herod., v. 71; Thucyd., i. 126; Pausan., i. 28). The narratives of that event imply that the Acropolis was already fortified by the Enneapylum, that the Areopagus was already the seat of the court which bore its name (see Areopagus), and that near the entrance of the citadel stood an altar of the Semnæ, or Furies, at which Cylon and his partisans were slain. This altar has been immortalised by Æschylus in the splendid conclusion of the *Eumenides*. Another sacred spot in early Athens must have been the *Leocorium*, where Hipparchus was assassinated (Thucyd., i. 20; vi. 57). This was a shrine erected in honour of the daughters of Leo, who were sacrificed by their father to Athena, in order to avert a pestilence. The nature of the legend testifies to the antiquity of the site. The words of Thucydides respecting Cylon imply that the early city was already surrounded by a ring-wall, and this probably remained intact until the invasion of the Persians, although the buildings within the walls underwent great alteration and improvements under the government of Pisistratus and his sons.

The reign of the Pisistratids was recognised by the ancients as marking an important era in Athenian topography. We have already mentioned the fountain of Enneacernus as being built by them. It was Pisistratus who laid the foundations of the great temple of Zeus Olympius upon the ancient site above mentioned. His magnificent design had an eventful history: left unfinished by its author, the Athenians, perhaps from dislike to the "tyrant," made no effort to complete it. At length, after receiving additions from various foreign princes, it was completed by Hadrian (c. 130 A.D.), and formed the grandest edifice in the region of the city which, in acknowledgment of the imperial munificence, was called Hadrianopolis. The Olympium was one of the largest temples in the world; but of its 124 Corinthian columns only 15 are now standing. The *Pythium*, or sanctuary of the Pythian

Apollo near the Olympium, was also ascribed to Pisistratus, whose grandson and namesake dedicated an altar within it (Thucyd., vi. 54). To Pisistratus was ascribed the founding of the *Lycæium*, or temple of Apollo Lyceus, which stood on the right bank of the Ilissus, a short distance from the city. The names both of Pericles and Lycurgus the orator are also associated with this building; yet it is not known who added the gymnasium close by, which afterwards became famous as the favourite haunt of Aristotle, and the birthplace of the Peripatetic philosophy. The yet more famous seat of the rival philosophy seems also to have owed something to the Pisistratids, for Hipparchus was said to have enclosed the *Academy* with a wall. This was a gymnasium surrounded by pleasant gardens lying to the N. of the city, about a mile from the Dipylum gate. It owes all its fame, of course, to its connection with Plato, who lived, taught, and was buried there. This site, so full of glorious memories, cannot now be identified with certainty. Its trees, like those of the Lycæium, were despoiled by Sulla to make implements of war. The name of Pisistratus is connected with another important site. Professor E. Curtius (*Attische Studien*, pt. 2), supposes that the most ancient Athenian market lay on the S. of the Acropolis, and that the Pisistratids superseded it by a new market at the northern foot of the Areopagus. Be this as it may, we are sure that, as early as their times, this site formed the centre of Athenian commercial and civic life. The narrow valley between the Pnyx Hill and the Areopagus, where older topographers placed the Agora, is not a spacious enough site for the purpose. The obvious locality for an Agora would be the rectangular space enclosed by the Areopagus on the S., by the Acropolis on the E., and on the W. by the eminence occupied by the Theseium. To the N. and N.E. no barrier existed; accordingly, the entrance was from the Dipylum gate on the N.W., and on the N.E. the market received extension in Roman times. The Agora thus stood in the region known as Cerameicus. But as the Cerameicus extended for some miles in a N.W. direction, it became divided by the city wall into the outer and the inner Cerameicus. The outer Cerameicus was an agreeable suburb, lying on the road to the Academy and Colonus, the home of Sophocles; and it was here that citizens who died in their country's wars received a public burial. Through gate Dipylum one passed into the inner Cerameicus, the most important quarter of which was naturally the Agora itself; and so it was common to speak of the Agora as "The Cerameicus." How much this market-place may have owed to the designs of the Pisistratids we cannot now determine. The statues of Harmodius and Aristogiton formed a conspicuous ornament of the south portion, and Thucydides (vi. 54) informs us that the grandson and namesake of Pisistratus adorned the Agora by building the altar of the twelve gods. If the Agora belongs to the age of Pisistratus, some of the civic buildings within it would also be coeval with him. Such were the Stoa Basileus, or Portico, where the archon basileus presided; the Bouleuterium, where the senate of 500 held its sittings; the Tholus close by it, where the Prytanes of the senate sacrificed—a circular building with a dome of stone, from whence it gained its name; and the Prytanæum, said to be founded by Theseus (Thucyd., ii. 15), which contained the hearth-fire of the state, and where the Prytanes and public benefactors had the privilege of dining at the public expense. The statues of the ten heroes (eponyms), who gave their names to the Athenian tribes, decorated the Agora probably from the first; against these statues were affixed public notices and proclamations. Other buildings in the Agora of later and ascertained dates will be enumerated in their proper place.

<sup>1</sup> Many of the names of the Attic demes, and indeed of Greek local names everywhere, were derived from plants and flowers; see Tozer's *Lectures on the Geography of Greece*, p. 338: "The most plausible derivation that has been suggested for the name 'Αθήραι is from ἀθή, the root of ἄθος, a flower; and Lobeck proposed to translate it by 'Florentia.'"—(*Ibid.*, p. 161).

The revolution which expelled the Pisistratids (510 a.c.), and gave Athens a free government, left its mark upon the topography of the city. The old Pelasgic fortress (τὸ Ἐρετρικόν), in which "the tyrants" had for a time held out, was now broken down, and the site occupied by its ruins was devoted by the Delphic oracle to eternal desolation. Only in the Peloponnesian war, when the country population was crowded within the city walls, do we read of this spot being occupied by dwellings (Thucyd., ii. 17). Another work which may probably be assigned to the age of Clisthenes is the first arrangement of the Pnyx, or place of public assembly. The hill that is commonly known as the Pnyx Hill contains one of the most remarkable ruins in Athens; the silence, however, of Pausanias respecting what was probably in his day already a mere ruin has occasioned some doubt concerning its proper identification. The spot in question consists of two terraces sloping down the hill towards the Areopagus, from S.W. to N.E. The upper terrace, indeed, does not slope, but is levelled out of the solid rock near the summit of the hill, being about 65 yards in length (E. to W.), and about 43 in breadth at its broadest part (N. to S.) It is bounded at the back (S.) by a rock-wall, and at the W. end there stands a cubical block, allowed to rise out of the solid rock when this upper terrace was levelled. There is good reason for considering this as the altar for the sacrifices (τὰ θύσια) with which every assembly of the ecclesia was opened (Bursian, *Philologus*, 1854, p. 369, *foli.*; Dyer, *Athens*, p. 462). The lower and considerably larger terrace is separated from the upper terrace by another wall cut out of the solid rock. This wall, which is nearly 126 yards long, is not quite straight, but encroaches slightly upon the upper terrace, and forms at the centre a very obtuse angle. At this point there rises, projecting from the wall, a large cubical mass, cut out of the solid rock, resembling somewhat, though on a larger scale, the altar described above. It is itself 11 feet square and 5 feet high, and stands on a platform consisting of three very massive steps. This remarkable monument has been recognised by tradition as the σκῆλα τοῦ Δημοσθένους, and almost every traveller since Chandler's time has regarded it as no other than the famous bema of the ancient Athenian assembly. The rock-wall from which it projects forms the chord of a vast semicircular space, the enclosure of its arc being a wall of "Cyclopean" masonry. The radius of the semicircle measures between 76 and 77 yards from this outer wall to the bema. Here, then, was the auditorium of the Pnyx. But several difficulties beset the identification. Towards the bottom of the lower bema Prof. E. Curtius (*Attische Studien*, pt. i.) has discovered another similar though smaller bema. Again, Plutarch asserts that the bema which had originally faced towards the sea was by the Thirty Tyrants turned round the other way, in their hatred of the maritime democracy. Moreover, if the block of marble above mentioned be rightly identified as the bema, then it would have the auditorium sloping downwards from it, an arrangement ill suited for addressing a tumultuous popular assembly. Dr Curtius accordingly pronounces the entire identification to be a mistake, and would regard this spot as a primitive precinct and rock-altar of the Most High Zeus. It would not be difficult, if space allowed, to disprove Dr Curtius's theory. Far more reasonable is the view of Dr Dyer (*Athens*, App. iii.) He thinks that the lower and smaller bema discovered by Dr Curtius was the bema of Clisthenes, which did (however much Plutarch's statement is discredited by his own absurd explanation) face in the direction of the sea. The orator would thus speak from the arc of the semicircle, having the audience above him. The Thirty may well have defaced the Pnyx, and it would have been natural for Thrasylus after the anarchy to restore it on

a large scale, hewing out what is still known as the bema, giving the semicircular wall a wider sweep, and raising the tiers of seats at least to a level with the new bema, if not above it. For there is no reason to suppose that the surface of the lower terrace has undergone no change in the lapse of centuries, or that the "Cyclopean" wall surrounding it never exceeded its present height.

A building of greater architectural importance and of equal interest belongs to this same period. Dramatic performances at Athens originally took place in wooden theatres extemporised for the occasion; but the fall of one of these led, in the year 500 a.c., to the erection of the marble theatre on a site already consecrated to Dionysus as the *Lenæum*, upon the S.E. slope of the Acropolis. (Suidas, s. v. Ἰπέρβια.) We may be sure that the first stone theatre was comparatively simple in construction, consisting of a *κοίλον* or auditorium, with tiers of rock-hewn seats, and an *ὄρχηστρά*, or space for the chorus, while the stage itself and its furniture were of wood. The excavation of the Dionysiac theatre in 1862 has made every one familiar with the row of marble thrones for the various priests and officers of state, the elaborate masonry of the stage, the orchestra floor, and other features. But these and other interesting decorations of the theatre belong to a later age. It was under the administration of Lycurgus the orator (337 a.c.) that the building was first really completed; and many of the sculptures which have been lately brought to light belong to a restoration of the theatre in the 2d, or perhaps even in the 3d, century A.D.<sup>1</sup>

Enough has now been said of the condition of Athens before the Persian War. It was surrounded by a ring-wall of narrow circuit, some doubtful traces of which are supposed to remain. At its centre stood the Acropolis, already crowded with temples and sanctuaries, some upon the summit, some built at its foot, and others—like the famous grotto of Pan, on the N.W. slope—mere caves in its rocky sides.

The Persian invasion, which forced the Athenians to take refuge in their "wooden walls," and to leave their city at the mercy of the barbarian, marked an important epoch in the annals of Athenian building. Upon the retreat of Mardonius, the Athenians returned to Attica to find their city virtually in ruins. Its fortifications and public buildings had been destroyed or burnt, and the private dwellings had been wantonly defaced or ruined by neglect. Amid the enthusiasm of hope which followed upon the great deliverance of Greece, a natural impulse led the Athenians to rear their city more glorious from its ruins. Themistocles fanned their patriotism with the foresight of a statesman, and Athens rose again with marvellous rapidity. This haste, however, though creditable to their patriotism, and, indeed, necessary in order to forestall the jealous opposition of Sparta, was not without its evils. The houses were rebuilt on their old sites, and the lines of the old streets, narrow and irregular as they had been, were too readily followed. A similar haste marked the rebuilding of the city walls, a work in which men and women, old and young, took zealous part, not scrupling to dismantle any building or monument, private or public, which could supply materials for the building. But in rebuilding the walls Themistocles gave them a wider circuit, especially towards the N. and N.E. (Thucyd., i. 90, 93). At the same time he determined to construct new harbours, and to fortify the Piræus, regarding the navy of Athens as her principal source of strength. It is doubtful whether the "Long Walls" formed a distinct portion of his designs; but he may certainly be regarded as the founder of the greatness

<sup>1</sup> The best account yet given of the Dionysiac theatre is to be found in Dr Dyer's recent work on Athens.

of Athens, the works and embellishments carried out by Pericles being only a fulfilment of the far-sighted aims of Themistocles. Thucydides (ii. 13) makes the circuit of the city wall to be 43 stades (about 5½ miles), exclusive of the unguarded space between walls; this is found to correspond accurately enough with the existing remains. In tracing the circuit of the ancient walls, we may take our start from the N.W. side of the city, at the one gate whose site is absolutely certain, the Thriasian gate (called also the Sacred gate, as opening upon the sacred way to Eleusis, and also τὸ Διῦλον, as consisting of two gates, perhaps one within the other), which is marked by the modern church of the Holy Trinity, a little N. of the bottom of Harmes Street—a spot attractive to the modern tourist through the beautiful "street of tombs" here laid bare by recent excavations. From the Thriasian gate the wall of Themistocles ran due E. for some distance; thence, skirting the modern theatre, it ran N.E., parallel to the modern Piræus Street as far as the Bank, when it returned in a S.E. direction across the site of the present Mint, as far as the Chamber of Deputies. Thence towards the S.E. it included nearly all the modern Royal Gardens, and then ran S.W., following the zig-zag of the hills above the north bank of the Ilissus, until westwards by a straight course parallel with the Acropolis it reached the Museum Hill. Thence it may be traced in a direction N.W. and N., following more or less the contour of the hills, until we return to our starting-point at the Dipylum gate. Eight other gates (exclusive of wickets, κλισίαι, which must have existed) are mentioned by ancient authors—the Piræan, Hippades, Melitides, Itonian, Diomaian, Diocharis, Panopia, and Acharnian. Their exact sites cannot be certainly fixed, but some of them may be determined within narrow limits, such as the Piræan gate, which led out of the Agora, and opened upon the long walls. Having completed the defences of the city proper, among which must be included the building of the north wall of the Acropolis (Dyer, p. 121), Themistocles proceeded to fortify the Piræus.

Athens, like most of the old Greek towns, was built, for greater security, at a distance from the coast, and only when more settled times brought her greater prosperity was a harbour formed at the nearest bay of Phalerum, near the modern church of St George. It is said that Themistocles would gladly have transported the Athenian population bodily from the upper city to the coast, there to form a great maritime state. Though this was impossible, yet he could strengthen Athens on the seaward side. The isthmus of Piræus, though somewhat more distant than Phalerum, presented obvious advantages as a seaport. It formed on its north side the spacious and secure basin of Piræus (now Port Drako), the north and south shores of which towards the entrance fall back into two smaller bays—harbours within the harbour—known respectively as the κωφὸς λιμὴν and κάβαρος. The neck of the isthmus on the south is formed by Port Zea (now Phanari), the entrance of which was secured by Phreattys, the headland of Munychia. Round to the east of the district of Munychia, again, and facing Phalerum, was the harbour known anciently as Munychia, and now as Port Stratiotiki. Themistocles thus, in giving up Port Phalerum, gave Athens three harbours instead of one. The fortifications of Piræus were conceived on a grand scale, and carried out with no sign of hurry. The whole circuit of Piræus and of the town of Munychia was enclosed alike on the sea and land sides by walls of immense thickness and strength, which were carried up to a height of more than 60 feet—this being only half the height intended by Themistocles! (see Grote, *Hist. Greece*, c. xlv.) The laying out of the new seaport belonged rather to the regime of Pericles (Grote, c. xlvii.) It was then that

Hippodamus, the eccentric architect, planned the Agora which bore his name; and the various public buildings which adorned Piræus doubtless arose with growth of Athenian commerce. The harbour-basin was lined with porticoes, which served as warehouses and bazaars. Two theatres existed in the town, and numerous temples. The local deity was Artemis Munychia; but the large number of foreigners (μέτροικοι) who became naturalised at this port led to the introduction of many foreign forms of worship. Artemis herself came to be identified with the Thracian Bendis, and her festival (τὰ Βανδίσια) is referred to in the immortal opening of Plato's *Republic*.

If not a part of the original designs of Themistocles, it was at least a natural development of them, to carry "Long Walls" from the newly-fortified Piræus to the upper city, and thus combine them both into one grand system of fortification. The experiment of connecting a town by long walls with its port had been already tried between Megara and Nisæa (Grote, *Hist. Greece*, c. xlv.), and it was now repeated on a grander scale under Cimon. From the portion of the city wall between the Museum and the Nymphs' Hill a sort of bastion was thrown out to S.W. so as to form an irregular triangle, from the apex of which a "long wall," about 4 miles long, was carried down to the N. portion of the Piræan fortifications; this was termed τὸ βόρειον τεῖχος. Another "long wall" of somewhat shorter length ran down to the wall of Phalerum, which had hitherto served as the port of Athens; this was τὸ θαλασσίον τεῖχος. A third wall, between the two, parallel to the first, and but a few yards from it (τὸ νότιον τεῖχος, τὸ δὲ μίσην τεῖχος), was afterwards added by Pericles, and the maritime fortifications of Athens became complete. But the city owed still more to the munificence of Cimon. Out of the spoils of his Persian campaign he fortified the S. side of the Acropolis with a remarkably solid wall, which terminated in a sort of bastion at the W. end. Here he reared a little temple of Athena Nike (otherwise called the Wingless Victory), although the existing sculptures of the frieze are pronounced on account of their style to belong to a somewhat later date (Pausan., i. 28, 3; Corn. Nep., *Cimon*, ii; Plutarch, *Cimon*, xiii.) It was Cimon who first set the example of providing the citizens with agreeable places for promenade (Plutarch, *ibid.*), by planting the Agora with plane trees, and laying out the Academy with trees and walks. It is probable that some of the porticoes in the Agora were built by Cimon; at all events, the most beautiful one amongst them was reared by Pisianax, his brother-in-law, and the paintings with which Polygnotus, his sister's lover, adorned it (representing scenes from the military history of Athens, legendary and historical) made it ever famous as the Ἰσθμὸς τοῦ αἰῶνος. One more building, the most perfect existing relic of ancient Athens, was also built by Cimon. The Theseium (as we still may venture to call it, in spite of the doubts lately cast upon its identification)<sup>1</sup> is a hexastyle Doric temple standing on an eminence due N. of the Areopagus, and is the first object which meets the eye of the tourist who approaches the city from the Piræus. Having served in Byzantine times for a Christian church, it is now a museum of antiquities, and contains some of the choicest treasures discovered by recent excavations.

We have now brought this sketch of Athenian topography down to the most distinguished period of Athenian history and Athenian architecture—the era of Pericles. As the champion of Hellenic freedom against the Persians, as the head of the Ionic confederation, Athens had suddenly grown to be the foremost city in Greece. But when one by one the confederate states sank into the position of subject-

<sup>1</sup> See Dyer, *Athens*, p. 230, *fol.*, who thinks it is really the temple of the Amazons.

allies; when the *symploce* of Athens passed insensibly into a *reparatio* (Thucyd., ii. 63); when the contribution of ships and men was commuted in most cases for a money payment, and the funds of the confederation were transferred from the Apollonium at Delos to the Athenian Acropolis,—an enormous revenue became at the disposal of the Athenian Government. It is to their credit that so little of it found its way into private pockets. It was natural for the thoughts of a Greek, especially of an Athenian, to turn to the decoration of his city; it was politic that the central city of the Ionian confederacy should be adorned with a beauty equal to her prestige. The buildings connected with the name of Cimon had been chiefly for utility or defence; those of Pericles were mainly ornamental. The first edifice completed by him seems to have been the Odeion, on the E. of the Dionysiac theatre, to serve as a place for recitations by rhapsodists, and for musical performances. It was burnt by Aristion during Sulla's siege of Athens, but afterwards rebuilt. Mention has already been made of the building of the Long Walls and the laying out of the Piræus by Pericles; but it was the Acropolis itself which witnessed the greatest splendours of his administration. Within its limited area arose buildings and statues, on which the genius of Phidias the sculptor, of Ictinus and Mnesicles the architects, were employed for years; while multitudes of artists and craftsmen of all kinds were busied in carrying out their grand designs.<sup>1</sup> The spoils of the Persian War had already been consecrated under Cimon to the honour of the national goddess, in the erection of a colossal statue of Athena by Phidias between the entrance of the Acropolis and the Erechtheium; her warlike attitude gained her the title of *Πρόμαχος*, and the gleam of her helmet's plume and uplifted spear was hailed by the homeward seaman as he doubled Cape Sunium (Pausan., i. 28). But the national deity was to receive yet greater honours at the hand of Pericles. That an old temple stood on the site afterwards occupied by the Parthenon is proved, less by the doubtful expressions of Herodotus (viii. 51, 55), and the testimony of later compilers like Hesychius, than by recent excavations, which reveal that a large temple must have been at least begun upon this spot when the Persian invaders destroyed the old buildings of the Acropolis by fire. Here, then, Pericles proceeded to rear what has ever since been known as the Parthenon. The designer of this masterpiece of architecture was Ictinus; the foundations of the old temple were at his suggestion extended in length and breadth, and thus arose upon the S. side of the Acropolis a magnificent temple of the virgin goddess. It was completed in the year 438 a.u. It stood upon the highest platform of the Acropolis, so that the pavement of the peristyle of the Parthenon was on a level with the capitals of the columns of the east portico of the Propylæa. The temple was built entirely of white marble from the quarries of Mount Pentelicus. Ascending a flight of three steps, you passed through the great east entrance into the Pronaos, wherein was stored a large collection of sacred objects, chiefly of silver. From the Pronaos a massive door led into the *cella*, called *Hecontopedes* (*ἑκαστόπυδος*), because it measured in length 100 Attic feet. The treasure here bestowed consisted chiefly of chaplets and other objects of gold. The west portion of the *cella* was railed off (by *κρύλλιδες*), and formed the *Parthenon* proper, i.e., the adytum occupied by the chryselephantine statue by Phidias of Athena Parthenos,—a work which yielded the pre-eminence only to one other statue by the same artist, viz., the Zeus at Olympia. In this adytum were stored a number of silver bowls and other articles employed at the Panathenæic festi-

vals. The westernmost compartment at the rear of the *cella* was the Opisthodomus, which served as the national treasury; hither poured in the tribute of the Athenian allies. It is important to remember that the Parthenon was never intended as a temple of worship; for this purpose there already existed another temple, presently to be described as the Erechtheium,—standing upon the primeval site of that contest between Athena and Poseidon which established the claim of the goddess to the Attic citadel and soil. The Parthenon was simply designed to be the central point of the Panathenæic festival, and the storehouse for the sacred treasure. The entire temple should be regarded as one vast *ἀνάθημα* to the national deity, not as a place for her worship. Thus directly in front of her statue in the *cella* there stood an erection, which has been mistaken for an altar, but which is more probably to be regarded as the platform which the victorious competitors in the Panathenæic contests ascended to receive, as it were from the hand of the goddess, the golden chaplets and vases of olive oil that formed the prizes (see Michaelis's *Parthenon*, p. 31). This consideration lends significance to the decorations of the building, which were the work of Phidias. Within the outer portico, along the outside of the top of the wall of the building, ran a frieze 3 feet 4 inches in height, and 520 feet in total length, on which were sculptured figures in low relief<sup>2</sup>, representing the Panathenæic procession. Nearly all of these sculptures are in the British Museum, and the entire series has been recently made complete by casts from the other fragments, and arranged in the order of the original design. The marvellous beauty of these reliefs, which was heightened originally by colour, has been long familiar to all the world from numerous illustrated descriptions. The procession of youths and maidens, of priests and magistrates, of oxen for sacrifice, of flute-players and singers, followed by the youthful chivalry of Athens on prancing steeds—is represented as wending its way from the west towards the eastern entrance.<sup>3</sup> Outside of the building, on the N. and S. sides, the metopes between the Doric triglyphs were filled with sculptures representing scenes from the mythical history of Athens. But the glory of the Parthenon were the sculptures of the E. and W. pediments. Unhappily but a few figures remain, and none are wholly perfect, of the statues which formed these groups; and Pausanias appears to have thought it superfluous to give a minute description of objects so familiar to every connoisseur and traveller. The sculptures on the eastern pediment related to the birth of Athena; the central group was early destroyed by the Byzantine Christians in converting the Parthenon into a church, with the Pronaos for its apse. But nearly all the subordinate figures are preserved in a more or less injured condition in the British Museum. The noble head of the horse of the car of Night, the seated female figures of "The Fates," and the grand torso commonly known as the "Theseus," are familiar to us all. It would be out of place here even to enumerate the many attempts that have been made to reconstruct the groups of either pediment. The sculptures on the W. represented the contest between Athena and Poseidon for the possession of Attica; and although scarcely any portions of these figures are now existing, yet they are better known to us than the E. pediment by means of the faithful (if clumsy) sketches made by the Frenchman Carrey in 1674, when they were in a comparatively perfect state. Those who desire to know all that is to be known concerning the sculptures of the Parthenon should consult the beautiful work of Michaelis, *Der Parthenon*, while the

<sup>1</sup> See the remarks of Mr Raskin, *Aratra Pentelica*, p. 174.

<sup>2</sup> He who desires to enjoy these sculptures, should come from a perusal of Michaelis's eloquent work *Der Parthenon*, and spend a day in the British Museum with the guide-book in his hand.

<sup>3</sup> See the animated description in Pintarch, *Pericles*, 12, *fol.*

measurements and architectural details of the edifice have never been so splendidly given as by our countryman Penrose, in his *Principles of Athenian Architecture*.

We will turn now to the other buildings of the Acropolis, none of which, however, are so full of significance as the Parthenon itself. For, indeed, standing as it does on the highest point of Athenian soil, its erection marked the culminating point of Athenian history, literature, politics, and art. The "Birth of Athena," over the eastern entrance, may symbolise to us the sudden growth of Athenian greatness, while in the contest between the armed goddess of peaceful wisdom and the violent god of sea, which adorned the western front, we may see an allegory of the long struggle between the agricultural and the maritime interests which forms the central thread of Athenian history.

Opposite to the Parthenon, on the northern edge of the Acropolis, stands another remarkable temple, far smaller in size, and built in the most graceful forms of the Ionic order. The Erechtheum appears to be designed expressly to contrast with the severe sublimity of the Parthenon; and on the side which confronts those mighty Doric shafts, the columns of the smaller building are allowed to transform themselves into Canephori. The temple of Athena Polias, which contained the ancient wooden image of the goddess, and formed the centre of her worship, suffered from fire in the Persian War (479 B.C.). A building so sacred would hardly have been allowed to remain for long in ruins; but it was reserved for Pericles to set about a complete restoration of it. However, the Peloponnesian War seems to have interrupted his designs, and in the year 409 B.C. the edifice was still unfinished,<sup>1</sup> and soon after this it was totally destroyed by fire. But soon afterwards it must have been rebuilt, without doubt retaining all its original features. The temple in its present state consists of an oblong cella extending from E. to W. From each side of the W. end of the cella projects a portico, forming a sort of transept. The eastern portico formed the temple of Athena Polias, upon the site of her ancient contest with Poseidon. The west portion was the Pandroseum, dedicated to Athena Pandrosus. The building thus formed two temples in one, and is styled by Pausanias a *δωδεκθεῖον*. It seems at a later time to have been commonly called the Erechtheum, because of a tradition that Erechtheus was buried on this site.

Among the many glories of the Acropolis, the Propylæa are described by Pausanias as being exceptionally magnificent (i. 22). They rivalled even the Parthenon, and were the most splendid of all the buildings of Pericles. The western end of the Acropolis, which furnished, and still furnishes, the only access to the summit of the hill, was about 160 feet in breadth,—a frontage so narrow, that to the artists of Pericles it appeared practicable to fill up the space with a single building, which, in serving the main purpose of a gateway, should contribute to adorn as well as to guard the citadel. This work, which rivalled the Parthenon in felicity of execution, and surpassed it in boldness and originality of design, was begun in the archonship of Euthymenes, in the year 437 B.C., and completed in five years, under the directions of the architect Mnésicles. Of the space which formed the natural entrance to the Acropolis, 58 feet near the centre were left for the grand entrance, and the remainder on either side was occupied by wings projecting 32 feet in front of the central colonnade. The entire building received the name of Propylæa from its forming the vestibule to the five door-

ways, still in existence, by which the citadel was entered. The wall in which these doors were pierced was thrown back about 50 feet from the front of the artificial opening of the hill, and the whole may therefore be said to have resembled a modern fortification, although, in fact, the Propylæa was designed, not for defence, but for decoration. The whole building was of Pentelic marble. The Megaron or great vestibule in the centre consisted of a front of six fluted Doric columns, mounted upon four steps, which supported a pediment, and measured 5 feet in diameter and nearly 29 in height, with an intercolumniation of 7 feet, except between the two central columns, which were 13 feet apart, in order to furnish space for a carriage-way. Behind this Doric colonnade was a vestibule 43 feet in depth, the roof of which was sustained by six inner columns in a double row, so as to divide the vestibule into three aisles or compartments; and these columns, although only three feet and a half in diameter at the base, were, including the capitals, nearly 34 feet in height, their architraves being on the same level with the frieze of the Doric colonnade. The ceiling was laid upon marble beams, resting upon the lateral walls and the architraves of the two rows of Ionic columns,—those covering the side aisles being 22 feet in length, and those covering the central aisles 17 feet, with a proportional breadth and thickness. Enormous masses like these, raised to the roof of a building, standing upon a steep hill, and covered with a ceiling which all the resources of art had been employed to beautify, might well overcome the reserve of a matter-of-fact topographer like Pausanias, and at once account for and justify the unusual warmth of his language when he is speaking of the roof of the Propylæa (i. 22). Of the five doors at the extremity of the vestibule, the width of the central and largest was equal to the space between the two central columns of the Doric portico in front, and the same also as that between the two rows of Ionic columns in the vestibule; but the doors on either side of the principal one were of diminished height and breadth, and the two beyond these again were still smaller in both dimensions. These five gates or doors led from the vestibule into a back portico 18 feet in depth, which was fronted with a Doric colonnade and pediment of the same dimensions as those of the western or outer portico, but placed on a higher level, there being five steps of ascent from the western to the level of the eastern portico. From the latter or inner portico there was a descent of one step into the adjacent part of the platform of the Acropolis.

The wings of the Propylæa were nearly symmetrical in front, each presenting on this side a wall adorned only with a frieze of triglyphs, and with antæ at the extremities. The inner or southernmost column of each wing stood in a line with the great Doric columns of the Megaron; and as both these columns and those of the wings were upon the same level, the three porticoes were all connected together, and the four steps which ascended to the Megaron were continued also along the porticoes of the two wings. But here the symmetry of the building ended; for, in regard to interior size and distribution of parts, the wings were exceedingly dissimilar. In the northern or left wing, a porch of 12 feet in depth conducted by three doors into a chamber of 34 feet by 26, the porch and chamber thus occupying the entire space behind the western wall of that wing; whereas the southern or right wing consisted only of a porch or gallery of 26 feet by 16, which, on the S. and E. sides, was formed by a wall connected with and of the same thickness as the lateral wall of the Megaron, and, on the W. side, had its roof supported by a narrow pilaster, standing between the N.W. column of the wing and an antæ, which terminated its southern wall. In front of the southern or right wing of the

<sup>1</sup> An important inscription in the British Museum gives a survey of the works as they stood in that year, drawn up by a commission appointed for the purpose. See *Greek Inscriptions in the British Museum*, vol. i. No. 35.



Propylæa there stood, so late as the year 1676, the small Ionic temple dedicated to Athena Nike, and commonly known by the ancients as the temple of the Wingless Victory (*Níky árrwpes*), which has already been mentioned as probably one of the buildings of Cimon. Perhaps before the 18th century this building was pulled down by the Turks, and the only remains of it—parts of the frieze built into a wall—which were known in his day were carried off by Lord Elgin, and are now in the British Museum. In 1835 careful excavations were made under the directions of Professor Ross, when not only were the remains of the Propylæa opened up far more clearly than before, but also nearly all the fragments of this little temple of Victory were discovered; they had been used for building a Turkish battery, and so preserved. Thus the temple was at once restored by a reconstruction of the original fragments. Few quarters of ancient Athens have received more advantage from judicious excavation in recent years than this western end of the Acropolis.

From the disastrous termination of the Peloponnesian war to the yet more fatal defeat at Chæroneia, the architectural history of Athens is a blank, only interrupted by the restoration of the Long Walls and the rebuilding of the fortifications of Piræus by Conon, both of which had been destroyed by Lysander. The financial genius of the orator Lycurgus, whose administration lasted from 338 to 325 B.C., replenished to some extent the exhausted resources of his country. He reorganised her finance, he catalogued and rearranged the sacred and national treasures, and brought order and efficiency into every department of state. This new impulse made itself felt in building activity. The Dionysiac theatre was now first completed; and though, as we have already seen, many of the sculptures and other marbles recently uncovered on its site are the restorations of a very much later age, yet we may confidently assume that in all material points the theatre as we are now able to view it represents the condition of the building as it stood in the time of Lycurgus. Another remarkable work which signalled his administration was the Panathenæic Stadium. On the southern side of the Ilissus, at right angles to the stream, a hollow space was scooped out of the soil, some 680 feet in length and 130 in breadth. It is possible that the site had been used for gymnastic contests before the orator's time; it was he, however, who first undertook to level it properly and lay it out. But it was reserved for the munificence of Herodes Atticus finally to complete it. He furnished the place with magnificent seats of Pentelic marble, tier upon tier, capable of accommodating, at the very least, 40,000 spectators. An attempt was recently made to excavate the Stadium, but it was found that every trace of antiquity had been destroyed, the marble having been used as a quarry for building purposes.

The administration of Lycurgus is an important era in Athenian architecture; for after his time we never seem to hear of any more buildings having been reared by the Athenian Government. The best-known extant edifices of the period immediately following were the work of wealthy private persons. Round the eastern end of the Acropolis, starting from the eastern entrance of the Dionysiac theatre, then leaving the Odeium of Pericles to the left, and thence sweeping westward to the Agora, there ran a street which formed a favourite promenade in ancient Athens, commonly known as the "Street of Tripods." It gained this name from the small votive shrines which adorned it, supporting upon their summit the bronze tripods which had been obtained as prizes in the choragic contests. The tripods thus mounted often themselves served as a frame to some masterpiece of sculpture, such, for example, as the famous satyr of Praxiteles. It had early become the custom to

dedicate the prize tripods within the sacred precincts of the theatre; but when this space was filled, they gradually extended all along this street, and their erection was made more and more a matter of private display. One of these shrines still stands, and is well known as the monument of Lysicrates. It bears the following inscription upon its architrave:—"Lysicrates, son of Lysitheides, of the deme Cicynna, was choragus; the tribe Acanantis gained the prize with a chorus of boys; Theon accompanied them upon the flute; Lysiades of Athens taught them; Eusnetus was archon." In other words, the date of this monument was 335 B.C. Fifteen years after that a somewhat similar shrine was reared at the topmost summit of the back of the great theatre, where an ancient grotto was by Thrasylus converted into a choragic monument. The Byzantine Christians transformed the building into a chapel of the Virgin, under the title of Panaghia Spiliotissa, or Our Lady of the Grotto. Early travellers describe this little shrine as consisting of three pilasters engaged in a plain wall, surmounted by an inscribed architrave; above was supported a figure of Dionysus, now preserved, but in a much injured state, in the British Museum. On the top of the statue originally rested the tripod that formed the prize of Thrasylus.

The Macedonian period again marks a new epoch in the history of Athenian topography. Henceforward almost every embellishment Athens received was at the hands of the various foreign princes, whose tastes inclined them to patronise a city so rich in historical associations, and so ready to reward each new admirer with an equal tribute of servile adulation. But whatever decoration the city might owe to royal vanity or munificence, her connection with these foreign potentates brought her far more of injury than advantage. She became entangled in their wars, and usually found herself upon the losing side.

Upon the death of Alexander the Athenians claimed their liberty, but they at once had to submit to Antipater (322 B.C.), who placed a garrison in Munychia. It perhaps was he who defaced the ancient Pnyx; at all events, from this time forward the political oratory of Athens became silent for ever. In 318 B.C. Demetrius the Phalerean was made governor of Athens by Cassander, and received every kind of homage from his servile subjects. But as soon as the other Demetrius, surnamed Poliorcetes, appeared in the Piræus, the Athenians welcomed him with open arms. For restoring to them the forms of democracy he was extolled with abject adulation, and had assigned to him a residence in the Opisthodomus of the Parthenon itself, where he profaned the sanctuary of the virgin goddess with unbridled sensuality. Upon the defeat of Antigonus at Ipsus (301 B.C.), Demetrius fled from Athens, and under Lachares, the leading demagogus of the time, the city enjoyed the shadow of independence. But the demagogus soon developed into a tyrant, and when Demetrius reappeared in 296 B.C. and besieged the city, Lachares had to fly from the indignation of the citizens, taking with him the golden shields that adorned the eastern front of the Acropolis, and having rifed the chryselephantine statue itself. Again, in 268 B.C., Athens endured a long siege from Antigonus Gonatas, who laid waste the surrounding country. Still more disastrous was the ineffectual siege by Philip V. in 200 B.C., who, pitching his camp at Cynosarges, destroyed everything that lay around—the temple of Heracles, the gymnasium there, and the Lyceium as well. At length, in 146 B.C., Greece became a Roman province, and Athens succumbed peacefully to the Roman yoke.

During the inglorious period of Athenian history which has just been sketched, several new buildings were reared by the munificence of foreign princes. Ptolemy Philadelphus

gave his name to a large gymnasium—the Ptolemæum—built by him near the Theseium. Attalus I, king of Pergamus, erected a stoa on the north-east of the Agora, and laid out a garden in the Academy. His successor, Eumenes II (197–159 B.C.), built another stoa near the great theatre. Antiochus Epiphanes designed the completion of the Olympium, a work which was interrupted by his death.

Under the rule of the Romans Athens enjoyed the privileges of a *libera civitas*, i.e., no garrison was introduced into the town, no tribute was levied upon it, and the constitution was nominally left unaltered. The Areopagus, indeed, under Roman influence, recovered some of its ancient power, and was made to take precedence of the more democratic assemblies of the Boule and Ecclesia. The revision also of the laws by Hadrian would, of course, introduce some changes. Yet it may surely be maintained that Athens under the Roman dominion was in a far better position than in the days before the taking of Corinth by Mummius, when she had been at the mercy of each successive Macedonian pretender. The Romans appear to have shown a remarkable respect for the feelings of the Athenian people. It would be superfluous here to recall the warm expressions of admiration which fall from Cicero and Horace when speaking of Athens. A visit to Athens was regarded by the educated Roman as a kind of pilgrimage.<sup>1</sup> One great disaster Athens did indeed undergo at the hands of Rome; this was the siege and plunder of the city by Sulla in the Mithridatic War. Yielding to the threats of the king and the representations of the villainous Aristion, the Athenians had joined the cause of the king of Pontus, and Sulla deliberately resolved to gratify his revenge (*Athenensis*, v. 47, *fol.*; *Plut.*, *Sulla*, 12). After a protracted siege, in which the inhabitants suffered the extreme of famine, mocked at once by the insolence of Aristion within, and pressed by a remorseless foe without, Athens at length was taken on March 1, 86 B.C. Many of the public buildings (happily not the most important) were overthrown, much of the sacred treasure was rifled by the soldiers, and many works of art, together with the library of Apollonius, containing the collections of Aristotle and Theophrastus, were carried off by the cultivated Sulla. The loss of life was also great: large numbers were butchered by the soldiery, and the Agora of Cerameicus flowed with blood. We are told that Sulla was wont to take credit for having "spared Athens." He did not indeed destroy it, but his conduct on this occasion alone would suffice to fix an indelible stain upon his memory. With this disastrous exception, Athens prospered under the Roman rule, and students from all parts of the Græco-Roman world flocked thither to attend the lectures of the philosophers and rhetoricians, or to view the countless works of art that adorned the city. Athenian society grew more and more academic. The current tone of educated circles was antiquarian even to pedantry.<sup>2</sup> The inscriptions relating to the Roman period clearly reveal to us the chief interests of contemporary Athenian life. Epitaphs in abundance testify to the *θεοειδαιμονία* which delighted in proper names derived from deities and religious ceremonies,<sup>3</sup> and the pride of genealogical pedantry. Honorary decrees abound to justify the charge of adulation which was the reproach of the later Athenians. But the commonest class of monuments are the gymnastic inscriptions, which give

us lists of the students from all quarters who, while pursuing their studies at Athens, enrolled themselves at a gymnasium, and there had the advantage of a social life and regular discipline, which reminds one somewhat of the college system in the English universities.<sup>4</sup>

But enough has now been said of the condition of Athenian society under the Roman rule; it is time to enumerate the embellishments which the city received during this period. It is uncertain at what exact date the Horologium of Andronicus of Cyrrhus was erected, which is generally known as the Tower of the Winds. It is first mentioned by Varro (*De Re Rust.*, iii. 5, 17), and is therefore older than 35 B.C., though certainly not earlier than the Roman conquest. This monument, so familiar to every scholar, is described by Virruvius (i. 6, 4) as an octagonal tower of marble. It stands at what anciently formed the eastern extremity of the Roman Agora, presently to be described. On each face, beneath the cornice, is sculptured the figure of the wind which blew from the corresponding quarter; on the top of the roof was a pedestal supporting a bronze triton (now destroyed), which was constructed to turn with the wind, and to point out the wind's quarter with a wand which he held in his hand. The sculptured figures of the winds are in good preservation, though of a declining period of art. They represent the four cardinal points and the intermediate quarters between these. Each has his emblems: Boreas, the north wind, blows his noisy conch; Notus, the rainy south wind, bears his water-jar; Zephyrus, the west wind, has his lap full of flowers, and so on. Under each figure are the remains of a sun-dial; and besides all these external features, the interior was constructed to form a water-clock, supplied with water from the spring at the Acropolis called Clepsydra. Thus in cloudy weather a substitute was provided for the dial and the sun.

The Agora in Cerameicus has already been described, and it was there noticed that the name Cerameicus often appears to be employed alone to denote the Agora. This may be easily accounted for. By the munificence of Julius Cæsar and of Augustus, a propylæum of four Doric columns, which still exist, was reared at the N.E. extremity of the Cerameicus Agora. The space between the central columns is about 12 feet, between the side columns not quite 5 feet. Over the pediment is a pedestal, with an inscription in honour of Lucius Cæsar, the grandson of Augustus, whose equestrian statue it appears to have supported. This propylæum has by some archaeologists been regarded as a portico of a temple to Athens Archegetis, to whom we learn, from an inscription on the architrave, that the building was dedicated out of the moneys given by Julius and Augustus. But there can be no reasonable doubt that these columns formed the entrance into a new Agora, dedicated to Athens Archegetis, just as it was customary with the Romans to dedicate a forum to some deity, and intended chiefly, it would seem, for the sale of the olive oil which formed so large and characteristic an export from Athens. This appears to be proved by the lengthy inscription (see Böckh, *Corp. Inscr. Græc.*, No. 355) which exists immediately within the entrance, and contains an edict of the Emperor Hadrian regulating the sale of oil and the duties payable upon it. It is easy to understand how, after the erection of the Roman Agora, the old market would be styled *ἡ ἀγορὴ τῆς Κεραμεικῆς* or simply Cerameicus, while the new oil-market would be distinguished as the

<sup>1</sup> The beautiful elegy of Propertius, beginning "Magnum iter ad doctas proficiscor Athenas" (iv. 21), is worth referring to.

<sup>2</sup> See note in No. 81 of *Great Inscriptions in the British Museum*, also No. 93.

<sup>3</sup> *Cf. ibid.*, No. 47; and Cumanides, *Ἐκρηγαστὸν Ἀρριεῖς ἐκρηγαστῶν, παλαιῶν*.

<sup>4</sup> See *Greek Inscriptions in the British Museum*, No. 89, and *fol.* The best account of the condition of Athens under the Romans may be found in a dissertation by H. L. Ahrens, *De Athenarum statu politico*, &c., and another by Professor Dittenberger, *De Ephebis Athenis*.

Agora.<sup>1</sup> The "Tower of the Winds," which had previously been erected, formed, with its useful timepieces, an appropriate embellishment at the north-eastern extremity. The market was enclosed by a wall, and it was reserved for Hadrian to complete its decoration by building a magnificent stoa on its northern side. Augustus himself received the honour of a small circular shrine upon the Acropolis, dedicated to Augustus and Roma. His son-in-law Agrippa was honoured by an equestrian statue in front of the Propylæa, the pedestal of which still exists. The Agrippæum was a theatre erected by Agrippa in the Cerameicus. It is possible, moreover, that the Diogeneium—the only gymnasium mentioned in the Ephæbic inscriptions of the imperial period—was built about this time. Its site has recently been thought to have been discovered about 200 yards east of the Tower of the Winds. Whatever licentiousness and misgovernment might mark the reign of succeeding emperors, they at all events refrained from doing injury to Athens. It had been proposed to finish the great temple of Zeus Olympius in honour of Augustus, but the design fell through, and it was reserved for Hadrian to finally complete the building of this magnificent temple, some six centuries from the time when the first stone was laid.

The reign of Hadrian made literally a new era in the history of Athens.<sup>2</sup> For Greece, and especially for Athens, this emperor entertained a passionate admiration. He condescended to hold the office of archon eponymus; in his honour a thirteenth tribe, Hadrianis, was instituted; and the emperor shared with Zeus the title of Olympius, and the honours of the newly-finished temple. While, however, many portions of the city bore witness to his munificence, it was in the south-eastern quarter that most of his new buildings arose, in the neighbourhood of the Olympium. This suburb was accordingly styled Hadrianopolis, or New Athens, to distinguish it from the old city of Theseus and of Themistocles. The arch of Hadrian still stands in a fairly perfect state, and marks the boundary between the ancient town and the new suburb embellished by Hadrian. On the north-western front of the architrave is the inscription *αὐτῷ εἰς Ἀθήνας Ἐρωτεύς ἡ πρὶν πόλις*; on the other front, *αὐτῷ εἰς Ἀδριανουῦ καὶ σὺν Ἐρωτεύς πόλις*. At the same time many of the older buildings underwent restoration at his command. Nor was his bounty shown in works of building alone. He ceded to the Athenians the island of Cephallenia, and bestowed upon them large presents of money, and an annual largess of corn.

The immediate successors of Hadrian were guided by his example. Antoninus Pius completed an aqueduct which Hadrian had commenced for bringing water into the town from the Cephissus. Marcus Aurelius visited Athens for the purpose of initiation at the Eleusinian mysteries.

The list of distinguished persons who made themselves famous as benefactors of Athens may be said to close with the name of Herodes Atticus the rhetorician. Herodes had counted Marcus Aurelius amongst his pupils, and was sure of a distinguished career at Rome; but, like the friend of Cicero, he preferred the more peaceful atmosphere of Greece and took the surname of Atticus. His ambition was to excel as a sophist, but he owed his fame yet more to the enormous wealth he inherited from his father, which he spent in works of public munificence. Various towns of Greece and even of Italy were enriched by his bounty, but Athens most of all. In addition to his many other benefactions, two architectural works in parti-

cular immortalised his name. One was the Stadium, which he adorned with magnificent marble seats. The other was the Odeium (see Pausan., vii. 20), the ruins of which are still to be seen under the south-west of the Acropolis. An odeium resembled a theatre in its general plan and the purposes it served: it differed apparently in being roofed in. The ancient theatres were open to the sky; but the most remarkable feature of this odeium, built by Herodes in honour of his deceased wife Regilla, was its roof of cedar, fragments of which were actually discovered in the excavations made upon this site in 1857.

It is a fortunate circumstance that the best and only extant account of ancient Athens came from the pen of a traveller who visited the city just at the time when the munificence of Hadrian and of Herodes had left nothing more to be added to its embellishment. The Odeium of Regilla, indeed, had not been commenced when Pausanias visited Athens, and he describes it later on in his seventh book. We may place his tour through Athens about the year 170 A.D. His manner of description is as methodical as a modern guide-book, and his very knowledge and appreciation of the endless masterpieces of Grecian art prevent him from covering his pages, like some modern tourists, with rapturous word-painting and expressions of delight. He begins his account of Athens (bk. i. ch. i.-ii. § 1) with a description of the Piræus and the harbours, and his first tour is along the road from Phalerum to the city, where he enters by the Itonian gate, within which he finds a monument to the Amazon Antiopa. In his next tour (ch. ii. § 2—ch. v.) he supposes us to start again from Piræus, and approach the city along the remains of the Long Wall. Thus entering the city by the Piræan gate,<sup>3</sup> he conducts us along the southern side of the old Agora (which he styles the Cerameicus), describing all the buildings that occur upon the way, from the Stoa Basileus and another stoa near it, adorned with a statue of Zeus Eleutherius, in an eastward direction past the temple of Apollo Patrons, the Metroum, the Bouleuterium, and Tholus, and other buildings, which lay at the northern and north-eastern foot of the Areopagus. This walk ends with the mention of the temple Eucleia and the Eleusinium. It is not easy to see why Pausanias here introduces an account of the fountain Enneacrurus and the temple of Demeter and Core, which every archæologist hitherto has placed near the Ilissus, in the south-eastern extremity of the city.<sup>4</sup> In his next walk (ch. xiv. § 5—xviii. § 3), having already described the south side of the Cerameicus Agora, he starts again from the Stoa Basileus, describes the buildings on the west and north of the Agora, and then enters the new or Roman Agora. In this tour he mentions the altar of Mercy, the gymnasium of Ptolemy, the Theseum, the temple of Aglauros, and the Prytaneium. In his next walk he starts from the Prytaneium, and proceeding eastward (ch. xviii. § 4, xix.), he mentions the temples of Sarapis and of Ileoithia, until, leaving the eastern end of the Acropolis at some distance on his right hand, he passes through the arch of Hadrian, and describes the Olympium and the other buildings of that emperor. This tour included the temple of Aphrodite *ἔν Κήποις*, the Cynosarges, the Stadium, and other buildings on both sides of the Ilissus. For his next walk he returns again to the Prytaneium (ch. xx.—xxviii. § 3), and enters the Street of Tripoda, which leads him to the temple and theatres of Dionysus, which he describes. Thus he at length reaches the western extremity

<sup>1</sup> The name Cerameicus is never used by writers of pre-Roman times for the old market; they always speak of "the Agora." Pausanias uses both words in their more modern meanings respectively.

<sup>2</sup> Many inscribed documents are found, dated "from Hadrian's first visit." See Dittenberger in the *Herwan*, 1872. p. 213.

<sup>3</sup> Curtius and others are probably mistaken in supposing the Dipylum to be the gate intended by Pausanias.

<sup>4</sup> Dr Dyer, in his recent work on Athens, Appendix I., endeavours to explain this difficulty by assuming the existence of two fountains called Callirrhoe, one of which (Enneacrurus) he places on the north-west of the Acropolis.

of the Acropolis, and entering through the Propylæa, he describes in order each object which adorned the summit, with an accuracy fully borne out by recent excavations. His last walk in Athens (ch. xxviii. § 4, xxix. § 1) conducts us through the various buildings at the western base of the Acropolis. From the temple of the Semnæ he passes to the court of the Areopagus, and the mention of this leads him to speak of the other judicial courts of Athens. The rest of his first book is occupied with an account of the suburbs of Athens—the Academy, the sacred way to Eleusis, &c., and the topography of Attica in general.

A few words may suffice to describe the ultimate fate of Athens. In the reign of Valerian the northern barbarians first appeared in the north of Greece, where they laid siege to Thessalonica. This extraordinary apparition having alarmed all Greece, the Athenians restored their city wall, which Sulla had dismantled, and otherwise placed the town in a state of defence sufficient to secure it against a *coup-de-main*. But under Gallienus, the next emperor, Athens was besieged, and the archonship abolished, upon which the strategos or general, who had previously acted as inspector of the Agora, became the chief magistrate. Under Claudius the city was taken, but recovered soon afterwards. Constantine the Great gloried in the title of General of Athens, which had been conferred upon him, and expressed high satisfaction on obtaining from the people the honour of a statue with an inscription,—a distinction which he acknowledged by sending to the city a yearly gratuity of grain. He also conferred on the governor of Attica and Athens the title of *Μέγας Δούξ*, or Grand Duke, which soon became hereditary, and his son Constans bestowed several islands on the city, in order to supply it with corn. In the time of Theodosius I., that is, towards the end of the 4th century, the Goths laid waste Thessaly and Epirus; but Theodorus, general of the Greeks, acted with so much prudence, that he saved the Greek cities from pillage and the inhabitants from captivity, a service which was most gratefully acknowledged. But this deliverance proved only temporary. The fatal period was now fast approaching, and, in a real barbarian, Athens was doomed to experience a conqueror yet more remorseless than Sulla. This was Alaric, king of the Goths, who, under the Emperors Arcadius and Honorius, overran both Italy and Greece, sacking, pillaging, and destroying. Never, indeed, did the fury even of barbarian conquest discharge itself in a fiercer or more desolating tempest. The Peloponnesian cities were overturned; Arcadia and Lacedæmon were both laid waste; the gulfs of Lepanto and Ægina were illuminated with the flames of Corinth; and the Athenian matrons were dragged in chains to satisfy the brutal desires of the barbarians. The invaluable treasures of antiquity were removed; stately and magnificent structures were reduced to heaps of ruin; and Athens, stripped of the monuments of her ancient splendour, was compared by Synesius, a writer of that age, to a victim of which the body had been consumed, and the skin only remained.

After this dreadful visitation Athens sank into insignificance, and became as obscure as it had once been illustrious. We are indeed informed that the cities of Hellas were put in a state of defence by Justinian, who repaired the walls of Corinth, which had been overturned by an earthquake, and those of Athens, which had fallen into decay through age. But from the time of this emperor a chasm of nearly seven centuries ensues in its history; except that, about the year 1150, it furnished Roger, the first king of Sicily, with a number of artificers, who there introduced the culture of silk, which afterwards passed into Italy. The worms, it seems, had been brought from India to Constantinople in the reign of Justinian.

Doomed, apparently, to become the prey of every spoiler, Athens again emerges from oblivion in the 13th century, under Baldwin and his crusaders, at a time when it was besieged by a general of Theodorus Lascaris, the Greek emperor. In 1427 it was taken by Sultan Amurath II.; but some time afterwards it was recovered from the infidels by another body of crusaders under the marquis of Montferrat, a powerful baron of the West, who bestowed it, along with Thebes, on Otho de la Roche, one of his principal followers. For a considerable time both cities were governed by Otho and his descendants, with the title of dukes; but being unable to maintain themselves in their Greek principality, they were at length succeeded by Walter of Brienne, who, soon after his succession, was expelled by his new subjects, aided by the Spaniards of Catalonia. The next rulers of Athens were the Acciajuoli, an opulent family of Florence, in whose possession it remained until 1455, when it was taken by Omar, a general of Mahomet II., and thus fell a second time into the hands of the barbarians. The victorious sultan settled a Mahometan colony in his new conquest, which he incorporated with the Ottoman empire; and Athens, as well as Greece, continued to form an integral part of the Turkish dominions, until the treaty of Adrianople in 1829, following up the provisions and stipulations of the treaty of London, 7th July 1827, established within certain limits the new state of Greece, of which Athens is now the capital.

From the period of the Ottoman conquest to the commencement of the insurrection in 1821 Athens was only known in history by two attempts, on the part of the Venetians, to expel the Turks and make themselves masters of the city. The first of these took place in 1464, only nine years after its capture by the Osmanlis, and proved an entire failure. But the second, which was undertaken in 1687, more than two centuries later, was crowned with a temporary and fatal success. In the month of September of that year, Count Königsmark, a Swede in the service of Venice, having disembarked at the Piræus a force of 8000 foot and 870 horse, forming part of the armament under Francesco Morosini, afterwards doge, marched to Athens, and having summoned the citadel without effect, he erected a battery of heavy ordnance on the hill of the Pnyx, and placing two mortars near the Latin convent at the western foot of the Acropolis, bombarded it for several days. The fire of the cannon was chiefly directed against the Propylæa, and the modern defences below that edifice, whilst the mortars continued, without intermission, to throw shells into the citadel. The consequence was, that the beautiful little temple of Nike Apteros, the frieze of which is now in the British Museum, was completely destroyed by the breaching battery, and the Parthenon, besides being greatly injured by the bursting of the shells, was, towards the close of the attack, almost rent in pieces by the explosion of a powder magazine, which reduced the middle of the temple to a heap of ruins, threw down the whole of the wall at the eastern extremity, and precipitated to the ground every statue on the eastern pediment. The western extremity was fortunately less injured, and a part of the Opisthodomos was still left standing, together with some of the lateral columns of the peristyle adjoining to the cell. But the shock was nevertheless abundantly disastrous; and when the Turks afterwards regained possession of the citadel (from which, on this occasion, they were expelled), they did all in their power to complete the destruction which the Venetians had so vigorously begun, by defacing, mutilating, or burning for lime every fragment of the edifice within their reach.

In the course of the revolutionary war Athens sustained three sieges. The first was laid by the Greeks in 1822. Having carried the town by storm, and driven

the Turks into the citadel, they established a strict blockade of the fortress, which was continued until the advance of the Pasha at the head of 4000 men induced them to abandon their enterprise, and fly, with the Athenians, to Salamis and Ægina. Two months afterwards, the Pasha having left Athens to the defence of 1500 men, the Greeks again ventured to attack the town, and succeeded in obliging the Turks to seek refuge in the citadel, which they forthwith determined to besiege; but, from ignorance and want of means, no progress whatever was made in the operation until they obtained possession of the well which supplied the garrison with water, when the Turks agreed to capitulate upon condition of being immediately embarked with their families and sent to Asia Minor. On various pretences, however, embarkation was delayed from time to time; and when intelligence at length arrived that a large Turkish force was advancing upon Athens, the Palicari, instead of manning the walls and preparing for a vigorous defence, rushed in a body to the houses where the prisoners were confined, and commenced an indiscriminate massacre. For this atrocity it is no palliation to remember that the Greek character had morally suffered from centuries of servitude, and that they had terrible arrears of vengeance to exact. The third siege was laid by the Turks in 1826. The Greeks had left a strong garrison in the Acropolis, with provisions for several months; and a spring of water having been discovered in the cave of Pan, and enclosed by Odysseus within the defences of the citadel, there was no danger of its being starved into a surrender. But the Turks having established batteries near the Pnyx and on the hill of the Museum, and having drawn a line of trenches round the citadel, with the view of intercepting all communication between the besieged and the Greek army, the garrison was hard pressed; and although Colonel Fabvier succeeded in forcing his way through the Turkish lines with 500 men and a supply of ammunition, and thus affording immediate relief, yet the total defeat of the Greek army under General Church at the battle of Athens, fought in the hope of raising the siege, led soon afterwards to the surrender of the Acropolis, which remained in the hands of the Turks until the termination of the revolutionary war.

In 1812 Athens could boast of a population of 12,000 souls, but during the war the greater part of the city was laid in ruins, and most of the inhabitants were dispersed. In 1834 it was declared the capital of the new kingdom of Greece. Great exertions have been made since then to restore the city; streets have been opened, levelled, widened; the ancient sewers have been cleared and repaired, and the marshes of Cephissus drained. Excavations of ancient sites and buildings have been carried out,—

chiefly through the efforts of the Archaeological Society of Athens, but the antiquaries and scholars of all Europe have anxiously watched their endeavours, and France and Prussia have vied with Great Britain in the prosecution of Athenian discovery. The Theseum has become a treasury of ancient sculpture, and a new archaeological museum has been also erected to contain the ever-increasing stores of ancient inscriptions and sculptures. The royal palace is a large building of Pentelic marble, situated in the eastern quarter of the city, on the highest part of the gentle eminence which rises from the level of the Ilissus and Cephissus towards Lycabettus. The University (*πανεπιστήμιον*) was founded in 1837, and numbers over 1200 students, while its staff of 52 professors includes the names of some of the most learned Greek archaeologists in Europe. In fact, the schools and other educational institutions of Athens are very numerous, and thoroughly efficient. The archaeological journals of Athens are full of information concerning the progress of excavations, and publish the texts of newly-discovered inscriptions. The population in 1871 was over 48,000, exclusive of the population of the Piræus, which would bring the total up to about 60,000. The harbour is visited by ships of all nations. A railway connects the Piræus with the city, and enters the ancient town about half-way between the site of the Dipylum and Piræan gates. The terminus stands in the midst of what once was the Agora in Cerameicus. The principal street is Hermes Street, running from west to east, a little north of the terminus, until it reaches the royal palace. Two other good streets, Athená Street and Æolus Street, traverse this at right angles. The other streets, with the exception of Stadium Street on the N.E., between the chamber of deputies and the University, are generally narrow and winding. Altogether, Athens, like the rest of Greece, is in a condition of increasing prosperity, and reaps the blessings of freedom. It is true that in our own country the ardent philhellenism of forty years ago has cooled down, and Greece is no longer an object of popular and sentimental admiration. Yet never did the scholars of Europe turn with keener zeal to the study of her ancient monuments; and if Attica were cleared for ever of brigands, and furnished with satisfactory roads, then in numbers tenfold greater than now would reverent travellers from the west of Europe delight to make their pilgrimage to the birthplace of philosophy, literature, and art.

The following are some of the most important works on the subject:—Leake's *Topography of Athens*; Wordsworth's *Athens and Attica*; Burian's *Geographie von Griechenland*, and article "Athens" in Pauly's *Real-Encyclopædie*, 2d ed.; E. Curtius's *Attische Studien*; Dyer's *Ancient Athens*; Wachsmuth's *Die Stadt Athen in Alterthum*. (E. L. H.)

**ATHENS**, the name of several towns in the United States of America, the chief of which are the following:—

(1.) The capital of a county of the same name in the S.E. of the state of Ohio, finely situated on the Hocking River. It is the seat of the Ohio university, which was founded in 1804. Population of county, 23,768. (2.) The capital of Clarke county, Georgia, on the W. bank of the Oconee River. It is the seat of the Georgia university, which was founded in 1801, and the central town of a large cotton-growing district. Population in 1870, 4251, of whom 1967 were coloured.

**ATHERTON**, or **CHOWBENT**, a township in the parish of Leigh and hundred of West Derby, in Lancashire, 200 miles from London. It is one of those places which have grown to wealth and populousness through the extension of the cotton trade. Besides its factories, it has collieries and ironworks. Population in 1871, 7531.

**ATHIAS**, **יוסף**, a celebrated rabbi and printer at Amsterdam, whose editions of the Hebrew Bible are noted for the general correctness of the text. Although he was a learned Hebraist, there are occasional errors in the points, especially in the edition of 1661, but many of these were corrected in that of 1667. He also printed several editions of the Bible in the corrupted Hebrew spoken by the Jews of Spain, Germany, Poland, and England. He died in 1700.

**ATHLETÆ** (*ἀθληταί*), among the Greeks and Romans, was the designation of persons who contended for prizes (*ἀθλα*) in the public games, exclusive of musical and other contests, where bodily strength was not called into play, though here also the word was sometimes applied, and it was even extended to horses which had won a race, and again metaphorically, e.g., to persons who had exerted themselves in good deeds (*ἀθλητὸς τῶν καλῶν ἔργων*). On the other

hand, the term was restricted so as to exclude those who, for mere exercise, without the incentive of a prize, practised in the daily gymnastic competitions. For such the name was *ἀγωναῖοι*, and this distinction was the more necessary in the later period of Greek history, when trained athletes became a professional class (400–300 B.C.) Yet it was not the value of the prizes themselves which led men to devote their lives to athletic exercises. That was at most very insignificant. But from the heroic legends of competitions for prizes, such as those at the obsequies of Patroclus (*Iliad*, xxiii. 257, *fol.*), from the great antiquity of the four national games of Greece (the Olympian, Pythian, Nemean, and Isthmian, with the local Panathenæa at Athens), and from the high social position of the competitors in early times, there gradually became attached to victory in one of these games so much glory, that the townsmen of a victor were ready, and frequently did, erect a statue to him, receive him in triumph, and care for him for the rest of his life. Against specially trained athletes the better class of citizens refused to compete, and the lists of the public games being thus left practically open only to professionals, training became more a matter of system and study, particularly in regard to diet, which was rigorously prescribed for the athletes by a public functionary, styled the *Ἀλεῖπτες*, who also had to save their bodies when practising. At one time their principal food consisted of fresh cheese, dried figs, and wheat bread. Afterwards meat was introduced, generally beef or pork; but the bread and meat were taken separately, the former at breakfast (*ἀπαιρον*), the latter at dinner (*δειπνον*). Except in wine, the quantity was unlimited, and the capacity of some of the heavy weights (*βαρεῖς ἀθληταί*) must have been, if such stories as those about Milo are true, enormous. Cases of death from apoplexy are not unknown among them. The Tarentine Iocus was an example of the strictest abstinence. Their instruction consisted, besides the ordinary gymnastic exercises of the palestra, in carrying heavy loads, lifting weights, bending iron rods, striking at a suspended leather sack (*κρίβκος*) filled with sand or flour, taming bulls, &c. Boxers had to practise delving the ground, to strengthen their upper limbs. The competitions open to athletes were in running, leaping, throwing the discus, wrestling, boxing, and the Pancratium, or combination of boxing and wrestling. Victory in this last was the highest achievement of an athlete, and was reserved only for men of extraordinary strength. The competitors were naked, having their bodies salved with oil. Boxers wore the *castus*, i.e., straps of leather, round the wrists and forearms, with a piece of metal in the fist, which was sometimes employed with great barbarity. An athlete could begin his career as a boy in the contests set apart for boys. He could appear again as a youth against his equals, and though always unsuccessful, could go on competing till the age of 35, when he was debarred, it being assumed that after this period of life he could not improve. It sometimes happened that an athlete would agree to allow his rival to win; but for that and other cases of dishonesty a fine was imposed, and the money expended in erecting statues, called *Zētes*, with warning inscriptions. The most celebrated of the Greek athletes whose names have been handed down are Milo, Hippothenes, Polydamas, Promachus, and Glaucus. Cyrene, famous in the time of Pindar for its athletes, appears to have still maintained its reputation to at least the time of Alexander the Great; for in the British Museum are to be seen six prize vases carried off from the games at Athens by natives of that district. These vases, found in the tombs, probably, of the winners, are made of clay, and painted on one side with a representation of the contest in which they were won, and on

the other side with a figure of Pallas Athena, with an inscription telling where they were gained, and in some cases adding the name of the eponymous magistrate of Athens, from which the exact year can be determined. Among the Romans, fond as they were of exhibitions of physical skill and strength, the profession of athletes was entirely an exotic, and was even under the empire with difficulty transplanted from Greece. The system and the athletes themselves were always purely Greek. (A. S. M.)

ATHLETIC SPORTS. Although this term is undoubtedly derived from the ancient *ἀθληταί*, the derivation does not exactly indicate its present meaning, inasmuch as our modern athletes are distinctly defined to be amateurs, in contradistinction to professionals. In fact, the former pursue the agonistic art, and should be styled "agonistics," if we may be allowed to invent such a word, rather than athletes. How the pastime came to be thus named in Britain some fifteen years ago it is hard to say. Till about 1860, all exercises wherein the feet played the principal part were rightly styled "pedestrianism." Up to that period all prizes, whether contended for by amateurs or professionals, were invariably in money. As the practice of the pastime, however, rapidly spread amongst the former, it was naturally found they were loth to compete on the same terms with, and for similar trophies as, the latter. Hence arose the modern definition of an amateur athlete, viz., "Any person who has never competed in an open competition, or for public money, or for admission money, or with professionals for a prize, public money, or admission money; nor has ever at any period of his life, taught, or assisted in the pursuit of athletic exercises as a means of livelihood; nor is a mechanic, artisan, or labourer." The moment this definition was brought into force a wide barrier arose between the two classes, and amateurs ceased to compete for money prizes amongst themselves, or against professionals, on any terms, unless they were willing to forfeit their status. A generic term was required for the new pastime, and in lieu of a better it was entitled "athletic sports," and its votaries "athletes." Hence the haphazard origin of the name. The birthplace of the modern pastime was undoubtedly the great universities and the military and public schools. Cricket has always been justly considered the national game of Great Britain during the summer months, and football fills the same position in the winter. For a month or six weeks in spring and autumn the weather and condition of the ground are in a transition state, and fit for neither of these pastimes, and athletic sports step in and appropriately fill the vacuum. About the year 1812 the Royal Military College at Sandhurst inaugurated modern athletic sports; but the example was not followed till about 1840, when Rugby School, Eton College, Harrow School, Shrewsbury Royal School, and the Royal Military Academy, Woolwich, came to the front. Fifteen years later college meetings had become pretty general both at Oxford and Cambridge. Kensington Grammar School had founded the first annual series of gatherings held in London, whilst Cheltenham College led the van amongst English public schools. After a few months' negotiations the first Oxford v. Cambridge annual meeting was held in 1864, and is justly considered the premier *réunion* of the whole year, the interest shown and the attendance of spectators being little, if anything, less than at the annual boat race between the same two seats of learning. Two years later the annual amateur championship meeting was founded in London, when the Oxford and Cambridge victors meet representatives from all parts of the United Kingdom, and contend for the "blue ribands" of the various events. The principal athletic society at present in existence is undoubtedly the "London Athletic Club," which takes the lead in all matters pertaining to athletics throughout the United Kingdom. In

England, moreover; there is now scarcely a country town, sea-side watering-place, cricket, rowing, or football club of importance, and probably not a single university or school, which does not hold its annual gathering for athletic purposes. Across the border the professional still far eclipses the amateur element, and there is no meeting of amateurs which can by any means be compared with the autumn Highland gatherings at Braemar and elsewhere. Until recently the two classes contended indiscriminately together, and the prowess displayed by such amateurs as the late Professor Wilson affords ample testimony that gentlemen were quite capable of holding their own against professionals. The number of annual amateur gatherings held in Scotland is, however, extremely limited, and scarcely extends beyond the universities and chief schools connected with Edinburgh, St Andrews, Glasgow, and Aberdeen. In Ireland the origin of the pastime is again attributable to the leading university, viz., Trinity College, Dublin, where the decision of isolated events, from about the year 1845, has given rise to the meetings now annually held in the picturesque College Park at Dublin. The Irish civil service meeting was inaugurated in 1867, since which time the pastime has made marvellous strides in the island, as is testified by important meetings now held annually in Belfast, Cork, and Galway; whilst the recently formed Irish Champion Athletic Club takes the lead, and stands in the same relation to Ireland as the London Athletic Club does to the whole of Great Britain. Athletic sports are also now extending on the Continent, at many great watering-places where Englishmen are in the habit of congregating. Our great colonies of India, Australia, New Zealand, and Canada, too, as well as the United States of America, Buenos Ayres, China, and even Japan, are not without their annual gatherings for competitors of the Anglo-Saxon race. The contests now classified under the name "athletic sports" are, walking, running, leaping, throwing the hammer, and putting the weight. Leaping and running are respectively identical with the *άλμα* and *δρόμος* of the ancient pentathlon; whereas throwing the hammer and putting the weight bear some resemblance to throwing the *δάρκος*. Spear-hurling, *ἀκόντιον*, is never practised but by a few gymnastic societies; and wrestling, *πάλη*, between amateurs is rarely witnessed. Running and leaping, however, are nearly always combined on every occasion in two descriptions of contests, viz., steeplechasing and hurdle-racing. Race-walking finds most votaries in London, the northern counties of England, and in Ireland, all distances, from 1 mile to 7, being in vogue amongst amateurs. Running comprises all distances from 100 yards up to 4 miles. Leaping may be divided into three principal heads, viz., running high-leaping, running wide-leaping, and running pole-leaping, which are found to be included in nearly every athletic programme. Adjuncts to these are the running hop-step-and-jump, standing high-leaping, and standing wide-leaping, all of which are favourite pastimes in the northern and midland counties of England. Vaulting, too, is sometimes practised, but belongs rather to the gymnasium than outdoor athletic arena. Steeplechasing proper can only be practised over natural courses across country. Its home is to be found at Rugby School, and amongst members of hare-and-hounds' clubs, who keep themselves in exercise thereby during the winter months. Artificial steeplechase courses are often made on athletic grounds; but the leaps are generally far too sensational, and constructed rather to afford merriment to the spectators than a fair test of the competitors' leaping powers. A prettier sight than a well-contested hurdle race can scarcely be imagined; but few first class hurdle racers are met with outside the universities and public schools. Scotland is undoubtedly the birthplace both of hammer throw-

ing and putting the weight, yet they are now practised at nearly every English and Irish meeting. 16 lb is the usual weight of the missile except in Ireland, where a 42-lb, and sometimes a 56-lb weight are put, though in a very unsatisfactory fashion. Athletic sports may be practised in a well-rolled grass field, but the best arena is an enclosure, with a regularly laid down running track, the foundation made of clinkers and rubble, and the surface of well-rolled fine cinder ashes. (H. F. W.)

ATHLONE, a market-town and parliamentary borough of Ireland, lying partly in West Meath and partly in Roscommon, 76 miles W. of Dublin. The River Shannon divides the town into two portions, which are connected by a handsome new bridge, opened in 1844. The rapids of the Shannon at this point are obviated by means of a canal about a mile long, which renders the navigation of the river practicable for 71 miles above the town. In the war of 1688 the possession of Athlone was considered of the greatest importance, and it consequently sustained two sieges, the first by William III. in person, which failed, and the second by General Ginkell, who, in the face of the Irish, forded the river and took possession of the town, with the loss of only fifty men. At the time of the last war with France it was strongly fortified on the Roscommon side, the works covering 15 acres and containing two magazines, an ordnance store, an armoury with 15,000 stand of arms, and barracks for 1500 men. There are two parish churches, two Roman Catholic parochial chapels, a Franciscan and Augustinian chapel, Presbyterian, Baptist, and Methodist meeting-houses, a court-house, bridewell, a union work-house, and two branch banks. It has a woollen factory, as well as other industries, and an active trade is carried on with Shannon harbour and Limerick by steamers, and with Dublin by the Grand and Royal Canals and several railway lines, while the importance of its fairs and markets is increasing. There is also a valuable fishery in the river. Market-days, Tuesday and Saturday. The borough returns one member to parliament. Population in 1871, 6566; constituency in 1873, 336.—Thom's *Irish Almanac* for 1875.

ATHOR, ΑΘΥΡΑ, ΗΛΘΟΡ, the name of the Egyptian divinity corresponding to Aphrodite or Venus. Her name meant "the abode of Hor" or Horus, and she was the mother of that deity in some of his types, and as such a form of Isis, of whom she was a higher or celestial manifestation. Her name occurs as early as the 4th dynasty, when she is styled the mistress of the tree, or sycamore, *neha*, or the tree of the south. Besides the local titles of the different cities over which she presided, she was entitled regent of the gods, living mistress of the upper and lower world, mistress of the heaven and regent of the West, and pupil or eye of Ra, or the Sun, with whom she was connected. In her celestial character she is represented as an Egyptian female holding a sceptre, her head surmounted by the sun's disk, horns, and uræus, and her flesh coloured blue, the colour of the heaven, or yellow, that of gold and beauty (according to Egyptian notions), a term also applied to Aphrodite in Greek mythology. In her terrestrial character she was the goddess who presided over sports and dancing, music and pleasure, like the Greek Aphrodite, the goddess of love; but her particularly special type was the white or spotted cow, the supposed mother of the sun. The solar deities Shu and Tefnut were her children. In certain legends she is mentioned as the seven cows of Athor, which appear in the Ritual or Book of the Dead. These cows, like the *Μοίρα*, or fates of Greek mythology, appeared at the births of legendary persons, and predicted the course and events of their lives. It is in this capacity that Athor is connected with Ptah, or the Egyptian Hephaestus, and is allied to Sekhet or Bast, called the wife

or mistress of Ptah, the seven cows being the mystical companions of the Apis, the second life or incarnation of the god of Memphis. She was also represented under the attributes and with the titles of the goddess Nut, or the Egyptian Rhea. The cow of Athor wore on its head the solar disk, and hawk feather plumes, like Amen Ra; and in this character as the great cow she has on some monuments her human head replaced by that of a cow wearing a disk, or the disk and plumes. This emblem also appears in her type at a later period, when her head is represented with long tresses curled into a spiral at the end, and she has the ears of a cow instead of human ears. Her head is then surmounted by a doorway or its cornice, emblem of the abode of the sun, which she represented. This is sometimes surmounted by the disk and horns. The handle of the sistrum, a musical instrument with bars, was generally made in shape of this head and cornice, as were also the capitals of the columns of Abusimbel, Denderah, and other temples, and the ægis and prows of certain arks. As the goddess of beauty and youth, many of the queens of Egypt assumed her type and attributes, and young females after death, at the Ptolemaic and subsequent periods, had their names preceded by that of the goddess, as both sexes had "Oairis" from the period of the 19th dynasty, that of Athor being a later substitute, and for females only. The third month of the Egyptian year was named Athor after her, and the fish *aten* or *latus*, a kind of carp, was sacred to her. The names and titles of Athor were very numerous, and she is named in the inscriptions the lady or mistress of Silsilis, Abusimbel, Pselcis, Ombos, Hermonthis, Apollonopolis Magna, and Heliopolis; but the chief site of her worship was Denderah, or Tentyris, where she is mentioned under many names, and all the different festivals held in her honour are recorded in the calendar of the temple. Athor is one of the oldest of the Egyptian deities, and her worship continued till the fall of Pantheism and substitution of Christianity. Her worship passed from Egypt to the neighbouring isles, cow-headed figures of the goddess having been discovered in Cyprus. Her figures and representation are common. Jablonski, *PantA.*; Wilkinson, *Manners and Customs*, iv. 387; Birch, *Gall. Antiq.*, p. 25; Duemichen, *Bauurkunde der Dendera*, Leip. 1865.

(s. r.)

ATHOS is, strictly speaking, the terminal peak of the most eastern of the three peninsular promontories which stretch south from the coast of Turkey (*Macedonia*), like the prongs of a trident, into the Archipelago. The name is, however, frequently extended to the whole peninsula which was formerly known as Acte. The peak rises like a pyramid, with a steep summit of white marble, to a height of 6780 feet, and can be seen at sunset from the plain of Troy on the one hand, and on the other from the slopes of Olympus. The whole peninsula is remarkable for the beauty of its scenery, with rocky heights and richly-wooded flanks, ravines "embowered from the light," and glimpses or free outlook over the surrounding sea. The climate is for the most part healthy and pleasant, though the western side is perhaps too much exposed to the heats of summer; and Lucian assures us that in ancient times the inhabitants were famous for longevity. Several towns, such as Sane, Dium, Olophyrus, Cleonæ, are mentioned by Greek and Latin writers as existing in the Peninsula; but none of them seem to have attained any great importance, and the most remarkable event in the ancient history of Athos is the construction by Xerxes of a ship-canal across the isthmus between the outer sea and the Singitic gulf. Traces of this canal, which was regarded by Juvenal as a Greek myth, have been found almost right across the neck of land, and leave no doubt of the truth of the story. In more modern times the district of Athos has been famous for

the number of hermits and monks that have found shelter in its retreats. No fewer than 935 churches, chapels, and oratories are said to exist, and many of the communities possess considerable wealth. It is believed that, with the exception of the dwellings of Pompeii, some buildings in



Sketch-Map of Athos.

Athos are the oldest specimens of domestic architecture in Europe; the shrines are in many cases richly decorated with goldsmith's work of great antiquity; the wealth of the monastic libraries in illuminated manuscripts has long been celebrated; and nowhere, according to Mr Tozer, can the Byzantine school of painting be studied with equal advantage. The date of the oldest religious foundation in the peninsula is not clearly ascertained, and the traditional chronology of the monks themselves can hardly be trusted. A bull of Romanus Lecapenus speaks of the restoration of the monastery of Xeropotamu in 924, and as early as 885 a rescript of Basil the Macedonian forbids the molestation of the "holy hermits." Lavra, on Mount Athos proper, was founded by St Athanasius in 960; the village of Carys or "The Hazels," was appointed as the seat of government about the same time; and shortly afterwards there followed the establishments Iveron (Ἰβήρων), Vatopedi (Βατοπέδιον), and Sphigmenu (τοῦ Ἐσφιγμένου). The family of the Comneni (1056-1204) bestowed great privileges on the existing monasteries, and added to their number. In the reign of Alexius the first purely Slavonic monastery (that of Chilandari) was founded by the Servian prince Stephen Nemenja. The taking of Constantinople by the Latins in 1204 brought persecution and pillage on the monks; this reminded them of earlier Saracenic invasions, and led them to appeal for protection to Pope Innocent III., who gave them a favourable reply. Under the Paleologi they recovered their prosperity, and were enriched by gifts from various sources. In the 14th century the peninsula became the chosen retreat of several of the emperors, and the monasteries were thrown into commotion by the famous dispute about the mystical Hesychasts. Their numbers were gradually increased by the foundation of St Dionysius, Simopetra, Constamonitu, Russico, St Paul. In the 15th century the monks made terms with the Turkish conqueror Amurath, and have since been molested by none of the sultans, except Soliman the Magnificent, who laid waste some parts of the peninsula. In 1545 Stavroniceta, the last monastery, was added to the list. The hospodars of Wallachia, who were recognised as the protectors of Athos, enriched the communities with lands; but a process of secularisation was commenced by



Capodistrias, who confiscated their holdings in Greece; and more recently they have been stripped of their possessions in the Danubian principalities. They still retain some property in parts of the Archipelago. A Turkish official resides at Caryes, and collects the taxes, which amount to about ten shillings a head; but for the most part the peninsula is autonomous, being governed by an administrative body of four presidents (*ἐπιστάται*), one of whom bears the title of "First Man of Athos," and a representative body called the Holy Synod, which consists of twenty members, one from each of the monasteries proper. These twenty communities are partly Cœnobitic, with a common stock and a warden, and partly Idiorrhhythmic, with a kind of republican government and great individual liberty. Besides these regular monasteries, there are a number of *ἀσκήτια*, or sketes, which consist of several small associations gathered round a central church and numerous little communities known as *καθίσματα*, or retreats, as well as genuine hermitages. Harmony is not always maintained between the different establishments, as was shown by a bitter dispute about a water-course between Cutlumsis and Pantocratoros, which led to the interference of the British consuls of Salonica and Cavalla, in answer to an appeal from some Ionian monks who were British subjects (1853). For the most part, however, the inhabitants of Athos are quiet and moderately industrious. They are said to number about 3000, all men; for no female, even of the lower animals, is permitted to desecrate the precincts of the Holy Mountain.

"*Descriptio Montis Atho et exil. ejus Monast.*," by Jo. Comnens in Montfaucon's *Palæographia Græca*; Georgiades, *Description of Present State of Samos, Patmos, Nicaria, and Mount Athos*, Lond. 1678; Lieut. Webber Smith, "On Mount Athos," &c., in *Journ. Roy. Geog. Soc.*, 1837; Curson, *Visits to Monasteries in the Levant*, 1849; Falmerayer, *Fragments aus dem Orient*, 1845; Gass, *Commentatio Historica*, &c., and *Zur Geschichte*, &c., 1866; Ramner's *Hist. Taschenbuch*, 1860 (art. by Fischon); Report by M. Minoia Minas, 1846; J. Müller, *Denkmäler in den Klöstern von Athos*; Langlois, *Athos*, &c.; Didron's *Iconographie Chrétienne*, 1844; *Journal Asiatique*, 1867; Tozer's *Highlands of Turkey*, 1869.

ATHY, a market-town of Ireland, county of Kildare, 34 miles S.W. of Dublin. It is a station on the Great Southern and Western Railway, and is intersected by the river Barrow, which is here crossed by a bridge of five arches. It has a church, a Roman Catholic chapel, a Presbyterian and a Methodist meeting-house, court-house, jail, two banks, hospital, dispensary, barracks, &c. Adjoining the town is a small chapel, an ancient cemetery, and a small Dominican monastery. Previous to the Union it

returned two members to the Irish parliament. The principal trade is in corn, which is ground at the neighbouring mills. Population in 1871, 4510.

ATINA, a town of Naples, province of Terra di Lavoro, near the Melfa, and 12 miles S.E. of Sora. It has a cathedral, convent, and hospital, with about 5000 inhabitants; but it is chiefly remarkable for its ancient remains, consisting of portions of its walls, the ruins of an extensive aqueduct, and numerous other structures, besides monuments and inscriptions. The city is of great antiquity, and was a place of importance down to the days of the Roman empire. It is remarkable now, as of old, for the exceptional coolness of its situation.

ATITLAN, a lake in the department of Solola, in Guatemala, 20 miles long, with an average breadth of 9 miles. It seems to occupy the crater of an extinct volcano, and its depth is reported to be very great. The scenery in the neighbourhood is striking and picturesque, the volcano of Atitlan rearing its head 12,500 feet above the level of the sea. A little Indian town, Santiago de Atitlan, nestles at the foot of the mountain.

ATLANTA, the capital of Georgia, one of the United States of North America, is situated about 7 miles to the S.E. of the Chattahoochee River, at an elevation of 1100 feet above the sea. Laid out in 1845, and incorporated as a city in 1847, it has since rapidly increased. It is the centre of a large trade in grain and cotton, and has extensive railway communication in all directions. Engineering work of various kinds is carried on, as well as the manufacture of cast-iron, flour, and tobacco. There are two national and two savings banks. Educational institutions are numerous, and comprise the North Georgia Female College, Oglethorpe College, a medical college, a university for men of colour, and a variety of schools. The state library contains upwards of 16,000 volumes. There are about thirty churches of different denominations, the Methodists being most largely represented, and one of their churches ranking among the finest buildings in the city. During the war Atlanta was the centre of important military operations, and suffered greatly in consequence (1864). It was strongly fortified by the Confederates, and defended, first by General Joseph E. Johnston, and then by General Hood, against the attack of General Sherman. Hood was compelled to evacuate the city, and Sherman afterwards retired to Chattanooga,—movements which occasioned the destruction by fire of the greater part of the buildings, both public and private. Population—(1860), 9554; (1870), 21,789.

## A T L A N T I C O C E A N

THE designation Atlantic Ocean, originally given to the sea that lies beyond the great range of Atlas in North-western Africa, has come to be applied, with the extension of geographical knowledge, to the whole of that vast ocean which occupies the wide and deep trough that separates the New from the Old World. Its limits are variously defined; some geographers regarding it as extending from pole to pole, whilst others consider it as bounded at its northern and southern extremities by the Arctic and Antarctic circles respectively. As the peculiarity of the physical conditions of the Polar Seas renders it on every account more appropriate to describe them under a separate head (POLAR REGIONS), the Atlantic will be here treated as bounded at the north by the Arctic circle, which nearly corresponds with the natural closing-in of its basin by the approach of the coasts of Norway and Greenland with Iceland lying between them; while at the south, where the basin is at its widest, its only boundary is the Antarctic

circle. The line which separates its southern extension from the Indian Ocean may be considered to be the meridian of Cape Agulhas, the southernmost point of the African continent; whilst the boundary between the South Atlantic and South Pacific would be formed in like manner by the meridian of Cape Horn. Although the Baltic and the Mediterranean are commonly regarded as appendages to the Atlantic, yet their physical conditions are so peculiar as to require separate treatment. (See BALTIC and MEDITERRANEAN.)

Every physical geographer who has written upon the Atlantic has noticed the curious parallelism between its eastern and its western borders,—their salient and retiring angles corresponding very closely to each other. Thus, beginning at the north we see that the projection formed by the British Islands (which extends much further westwards at 100 fathoms below the surface than it does above the sea-level), answers to the wide entrance to Baffin's Bay;

whilst, on the other hand, the projection of the American coast at Newfoundland answers to the Bay of Biscay. Further south, the great rounded prominence of Northern Africa corresponds with the vast bay that stretches from Nova Scotia to St Thomas; whilst the angular projection of South America towards the east corresponds with that receding portion of the mid-African coast-line which is known as the Gulf of Guinea.

This correspondence suggested to Humboldt the idea that the Atlantic basin was originally excavated by a very violent rush of water from the south, which, being repulsed by the mountain ranges of Brazil, was directed by them towards the coast of Africa, and formed the Gulf of Guinea; being there checked and turned to the west by the mountains of Upper Guinea, the stream excavated the Caribbean Sea and the Gulf of Mexico; and issuing thence, it ran between the mountains of North America and Western Europe, until it gradually diminished in velocity and force, and at length subsided. Another writer speaks of the basin of the Atlantic as an immense rift, made by some terrible force, which rent the surface-land asunder, but left the edges of the ravine to show by their form that they had once been connected. For neither of these speculations, however, is there the smallest foundation in fact. What has to be accounted for, indeed, in regard to either of the great areas at present covered by water, is not so much the excavation of its sea-bed, as its segregation from an ocean originally universal by the boundaries that now enclose it; in other words, not so much the depression of the bottom of its basin as the elevation of its sides. Not only is the proportion of the land-surface of the globe to its water-surface scarcely more than one-third (being as 1 to 2.78), but the entire mass of the land which thus covers little more than one-fourth of the surface of the globe is quite insignificant in comparison with that of the water which covers the remaining three-fourths. For whilst the average elevation of the whole land is certainly less than one-fifth of a mile, giving from 9 to 10 millions of cubic miles as the total mass of land that rises above the sea-level, the average depth of the sea (so far as at present known) may be taken at about 2 miles, giving a total of nearly 290 millions of cubic miles of water, which is therefore about *thirty times* the mass of the land. From the computation of Keith Johnston, it appears that, "if we conceive an equalising line, which, passing around the globe, would leave a mass of the earth's crust above it, just sufficient to fill up the hollow which would be left below it, this line would then fall nearly a mile below the present level of the sea." This is tantamount to saying that, if the solid crust of the earth could be conceived to be smoothed down to one uniform level, its entire surface would be covered with water to the depth of about a mile. Hence it is obvious that as the elevation of that crust into land over certain areas must be accompanied by a corresponding depression of the sea-bed over other areas, such depression, augmenting in those areas the previous depth of the aqueous covering of the globe, would be quite sufficient to account for the existence of the great oceanic basins, without any excavating action. And a confirmation of this view is found in the fact, ascertained by recent soundings, that the deepest local depressions of the sea-bed are met with in the neighbourhood of islands that have been raised by volcanic agency. Further, as the quantity of solid matter that must have been removed (on Humboldt's hypothesis) in the excavation of the Atlantic valley must have been nearly four times as great as that which forms the whole known land of the globe, and as it is impossible to conceive of any mode in which such a mass can have been disposed of, we may dismiss that hypothesis as not only untenable in regard to the Atlantic basin, but

as equally inapplicable to any other valley of similar width and depth.<sup>1</sup>

The general direction of geological opinion, indeed, has of late been, on physical grounds, towards the high antiquity of the great oceanic basins, not exactly as at present bounded, but as areas of depression having the same relation as they have now to the areas of elevation which form the great continents. Thus Sir Charles Lyell was strongly impressed by the fact that the mean depth of the sea is not improbably fifteen times as great as the mean height of the land; and that depressions of the sea-bottom to a depth of three miles or more extend over wide areas, whilst elevations of the land to similar height are confined to a few peaks and narrow ridges. Hence, he remarked, "while the effect of vertical movements equalling 1000 feet in both directions, upward and downward, is to cause a vast transposition of land and sea in those areas which are now continental, and adjoining to which there is much sea not exceeding 1000 feet in depth, movements of equal amount would have no tendency to produce a sensible alteration in the Atlantic or Pacific Oceans, or to cause the oceanic and continental areas to change places. Depressions of 1000 feet would submerge large areas of the existing land; but fifteen times as much movement would be required to convert such land into an ocean of average depth, or to cause an ocean three miles deep to replace any one of the existing continents."<sup>2</sup> And Professor Dana, who, more than any other geologist, has studied the structure of the existing continents and the succession of changes concerned in their elevation, has been led, by the consideration of the probable direction of the forces by which that elevation was effected, to conclude that the defining of the present continental and oceanic areas began with the commencement of the solidification of the earth's crust. "The continental areas are the areas of least contraction, and the oceanic basins those of the greatest, the former having earliest had a solid crust. After the continental part was thus stiffened, and rendered comparatively unyielding, the oceanic part went on cooling, solidifying, and contracting throughout; consequently, it became depressed, with the sides of the depression somewhat abrupt. The formation of the oceanic basins and continental areas was thus due to 'unequal radial contraction.'" In the opinion of Professor Dana, there has never been any essential change in the relations of these great features. "It is hardly possible," he says, "to conceive of any conditions of the contracting forces that should have allowed of the continents and oceans in after time changing places, or of oceans, as deep nearly as existing oceans, being made where are now the continental areas; although it is a necessary incident to the system of things that the continental plateaus should have varied greatly in their outline and outer limits, and perhaps thousands of feet in the depths of some portions of the overlying seas, and also that the oceans should have varied in the extent of their lands." . . . "The early defining, even in Archæan times, of the final features of North America, and the conformity to one system visibly marked out in every event through the whole history—in the positions of its outlines and the formations of its rocks, in the character of its oscillations, and the courses of the mountains from time to time raised—sustain the statement that the American continent is a regular growth. The same facts also make it evident that the oceanic areas between which the continent

<sup>1</sup> The case of such a shallow trough as that of the English Channel, of the former continuity of whose sides there is ample evidence, whilst its bottom is nowhere 500 feet beneath the surface, is obviously altogether different. The extraordinary depth of the Mediterranean basin, on the other hand, affords strong reason for regarding it as, like the Atlantic, a portion of the original area of depression, circumscribed by the elevation of its borders.

<sup>2</sup> *Principles of Geology*, 11th ed. vol. i. p. 249

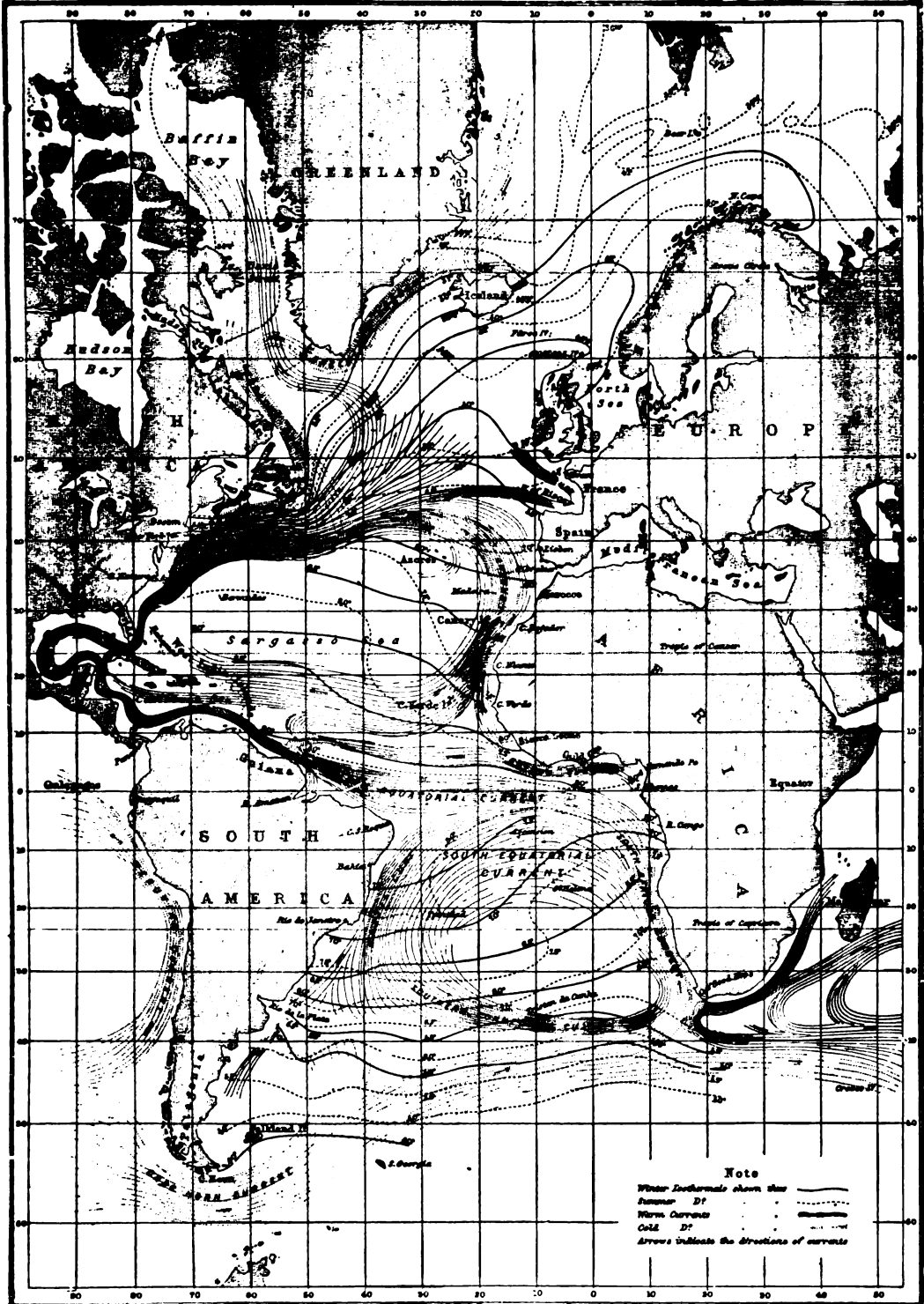



lies have been chief among the regions of the earth's crust that have used the pent-up force in the contracting sphere to carry forward the continental developments. If this was true of the North American continent, the same in principle was law for all continents.<sup>1</sup>

*Dimensions of the Atlantic.*—The length of the Atlantic basin, considered as extending from the Arctic to the Antarctic circle, is nearly 8000 geographical miles. The nearest approach of its boundaries is between Greenland and Norway, whose coasts are only about 800 miles apart. They thence recede from each other towards the south, as far as the parallel of 30° N. lat., where, between the peninsula of Florida and the western coast of Morocco, there is an interval of 70° of longitude, or about 3600 geographical miles. The channel then rapidly narrows as it passes southward, so that between Cape St Roque in Brazil (5° S. lat.) and the coast of Sierra Leone (between 5° and 8° N. lat.) the African and American continents approach within 1500 miles of each other. The sudden eastward recession of the African coast as it approaches the equator, and the westward trend of the South American coast-line between Cape St Roque and Cape Horn, widen out the South Atlantic basin to the same breadth as that of the North Atlantic in the parallel of 30° N.,—the interval between the Cape of Good Hope and the estuary of La Plata, in the parallel of 35° S., being no less than 73½° of longitude, or about 3600 geographical miles.

The depth of the North Atlantic has been more carefully and systematically examined than that of any other oceanic basin; and the general contours of its undulating sea-bed may now be regarded as pretty well determined. Putting aside the older soundings as utterly untrustworthy, and accepting only those taken by the modern methods, whose reliability has been amply tested by the accordance of diversified experiences, we can now assert with confidence that scarcely any portion of its floor has a depth exceeding 3000 fathoms, or about 3¼ miles, the greatest depth determined by the recent "Challenger" soundings, which was that of a limited depression about a hundred miles to the north of St Thomas, having been 3875 fathoms, or about 4¼ miles. Except in the neighbourhood of its coast-lines, and in certain shallower areas to be presently specified, the floor of the basin at its widest part seems to lie at a depth of from 2000 to 3000 fathoms, its slopes being extremely gradual. The central portion of the principal basin of the North Atlantic, however, is occupied by a plateau of irregular shape, of which a considerable part lies at a less depth than 2000 fathoms. Of this plateau the Azores may be regarded as the culmination; and that group being taken as its centre, it may be said to extend to the north as far as lat. 50°, and to the south-west as far as the tropic of Cancer. The northern extension of this plateau narrows out into a sort of isthmus, which connects it with the plateau that occupies a great part of the Atlantic basin to the north of 50° N. lat.; and it is across this isthmus, and along the bottom of the deep narrow valley on either side of it, that the telegraph cables are laid between Ireland and Newfoundland. Whether its south-western prolongation, known as the "Dolphin Rise" (fig. 1, *infra*) extends to the equator, so as to become continuous with the elevated area which culminates in St Paul's rocks, and by a further southward extension becomes continuous either with the volcanic elevation of St Helena and Ascension Island, or with the elevation in the middle of the South Atlantic which culminates in the island of Tristan da Cunha (fig. 2), has not yet been ascertained. According to the view already suggested as to the formation of the Atlantic basin, the plateau might

be regarded as representing the original sea-bed (from which the Azores have been lifted up by volcanic action); whilst the deep valleys on either side of it are "areas of subsidence" answering to the "areas of elevation" of the land that borders them.

Generally speaking, the depths of these valleys increase pretty rapidly with the distance from the shore-line, so that the contour-lines of one and two miles follow the shore-lines pretty closely. But there are two localities in which shallow water extends to a much greater distance from land than it appears to do elsewhere. One of these lies in the neighbourhood of the British Isles. For a distance of about 230 miles to the westward of Ireland there is a slope of only about 6 feet in a mile; but in the next 20 miles there is a fall of 9000 feet, after which there is little change of level for 1200 miles. Hence as the depth of the sea immediately surrounding the British Isles is nowhere 100 fathoms (so that an elevation of their whole area to that amount would unite these islands not only to each other but also to the continent of Europe), it is obvious that the platform on which they rest is really, although now submerged, a part of the land-mass of Europe. Another of these extensive shallows is that of which the Banks of Newfoundland form the highest part; and of the existence of this a probable explanation may be found in the accumulation of the rock-masses that are brought down by icebergs every summer from the coasts of Greenland and Labrador. For it is now generally admitted that these icebergs are really parts of glaciers, that were originally formed on the mountain-slopes of Greenland and Labrador, and then descended valleys which open out on their coasts, so as, on arriving at the mouths of these valleys, to detach themselves and float away, being borne southwards by the Folar Current to be presently described. Most Arctic icebergs of which a near view can be obtained are observed to have upon them a considerable number of pieces of rock, sometimes of a very considerable size; and these are of course deposited on the sea-bed when the icebergs melt (which they usually do on the borders of the Gulf Stream), thus forming a vast conglomerate bed, to which parallels are not improbably to be found in various geological epochs.

*Geological Age of the Atlantic Basin.*—Guided by the principle that great oceanic basins are to be considered rather as original marine areas that have been limited by the elevation of their boundaries, than as having been formed by the excavation of terrestrial areas, we have to inquire what evidence there is that the basin of the Atlantic has undergone any considerable change within a comparatively recent period.

As has been pointed out by Prof. Wyville Thomson (*Depths of the Sea*, p. 473), it is difficult to show that any oscillations have occurred in the north of Europe since the termination of the Secondary period, to a greater extent than from 4000 to 5000 feet,—this being the extreme vertical depth between the base of the Tertiaries and the highest point at which Tertiary or post-Tertiary shells are found on the slopes and ridges of mountains. Such oscillations, while considerably modifying the boundaries of the Atlantic, would not seriously affect the condition of the deeper parts of its sea-bed; and hence it may be concluded that the two deep valleys, one on the European side of the modern volcanic platform of the Azores, and the other on the American, each having a width of 600 or 700 miles, and an average depth of 15,000 feet, could neither have been formed by such oscillations, nor could, when once formed, have been converted into dry land. It will be presently shown that this idea of the existence of an Atlantic basin corresponding generally to that now existing, as far back as the later Secondary period, is strongly supported by the evidence

<sup>1</sup> "On some Results of the Earth's Contraction from Cooling," in *Amer. Journ. of Science*, June 1873.

recently obtained of the continuity of animal life on the Atlantic sea-bed from the Cretaceous epoch to the present time.

Important information as to the changes which the seabed of the Atlantic has undergone within the later geological periods, may be gathered from the structure of the islands which lift themselves above its surface. Along its eastern border, at no considerable distance from the coast of North Africa, there are three principal groups,—the Madeiras, Canaries, and Cape Verd,—all of which have an evidently volcanic origin, and rise up from the eastern slope of the basin, where it is progressively shallowing towards its continental shore-line. Further out, in mid-ocean, lies the group of the Azores, which also is volcanic, and rises from the plateau already spoken of; but between this area and the slope from which the Madeiras and Canaries are based is a very deep channel, ranging downwards to at least 15,000 feet; and a like depth is also found between the Azores and the coast of Portugal. The structure of all these groups of islands gives obvious indications of their formation by separate igneous eruptions in a sea of great depth; and the earliest of these eruptions seems to have taken place in the later Miocene period. As soon as the first solid lavas raised their heads above water, and were thus exposed to the action of the waves, fragments were detached and rounded on the shore; and these being swept off, with the *débris* resulting from their attrition, formed deposits of various kinds upon the slope of the cone, in which corals, shells, &c., were embedded. These fossiliferous deposits have been subsequently elevated to heights of from 1500 to 2000 feet above the level of the sea, showing a rise of the base of the craters; progressive additions have been made to their upper part by the piling up of basaltic and trachytic lavas.<sup>1</sup> That this state of activity still continues is proved by the fact that in 1811 a new island was temporarily formed in the Azores group, off St Michael, by the throwing-up of ashes, and the formation of a cone about 300 feet high, with a crater in the centre. This island, to which the name Sabrina was given, was soon washed away by the waves. And only a few years since, another submarine eruption in this neighbourhood was indicated by earthquakes, jets of steam and columns of smoke, and floating masses of scorise. All these considerations concur (as Sir Charles Lyell, *loc. cit.*, justly urges) to negative on geological grounds the hypothesis which has been advocated by some eminent naturalists, that the Azores, Madeiras, and Canaries are the last remaining fragments of a continuous area of land which once connected them with the west of Europe and North Africa.

Proceeding to the south of the equator, we meet with similar evidence of volcanic activity in the structure of the only two islands, Ascension and St Helena, which lie near the line stretching from the Cape Verd group to the Cape of Good Hope; and these also arise from a plateau of considerably less depth than the circumjacent area whose eastern slope gradually shallows to the coast of South Africa. This plateau stretches in a north-westerly direction towards the equator, so as to meet it in from 20° to 22° W. long.; and here indications of volcanic activity—earthquakes, troubled water, floating scorise, and columns of smoke—have been several times observed since the middle of the last century, betokening the probable formation of an island or an archipelago in that locality.

Nearly midway between the southern prolongations of the African and American continents, the solitary peak of Tristan da Cunha (fig. 2) lifts itself above the ocean; this also is volcanic, and seems to rise from a broad base

<sup>1</sup> See Sir C. Lyell's account of them in his *Principles of Geology*, 11th ed. p. 407, *egg*.

of general elevation resembling the plateau of the North Atlantic.

The entire chain of the Greater and Lesser Antilles, which stretches from the delta of the Orinoco to the peninsula of Florida, and forms the eastern boundary of the Caribbean Sea, seems to have been in like manner elevated by volcanic action. That this elevation, like that of the groups of islands on the eastern side of the Atlantic, took place for the most part during the later Tertiary period, is shown by the occurrence of shells, corals, &c., of upper Miocene age, in the upraised sedimentary beds of several of the islands; while the presence of "fringing reefs" of coral around the shores of many of the West India islands is an indication that they lie in an area in which elevation is still proceeding. The channels by which they are separated are so deep as to render it very unlikely that there was ever a continuity of land between them; and the occasional recurrence of earthquakes and volcanic eruptions at different points of this "line of fire," shows that the plutonic action by which the islands were raised is still going on beneath.

The case is very different, however, in regard to the Bermuda group, which constitutes a singular exception to the general fact of the absence in the Atlantic of those coral islands that are so numerous in the Pacific. This group consists of about 300 islands, of which, however, only five are of any considerable size; and these rise from a shoal or platform of about 23 miles long by 13 miles broad, the channels between the islands being very shallow, while at a small distance from the edge of the shoal, the bottom rapidly deepens to 15,000 feet. The islands are entirely composed of upraised beds of coral, shells, &c. (the highest elevation being only about 180 feet above the sea-level); and the shoal itself appears to have the like structure throughout, no traces of any other rock than a limestone formed by the metamorphoses of coral being anywhere met with. Hence, as this insular platform proves to be the summit of a submarine column of 15,000 feet high, rising from a very small base, and as nothing we know of the structure of mountains—volcanic or other—would justify us in supposing that a column of such a height could be formed in any other way than by coral growth, the structure of the Bermuda group would seem to indicate a progressive subsidence of the bed of this part of the Atlantic during its formation, corresponding to that which (according to the well-known views of Mr Darwin) is at present in progress over a large area of the Pacific. It is probable that this coral growth was determined in the first instance by the existence of a submarine mountain, of which the summit lay near the surface, or lifted itself above it; that as soon as this came to be submerged, the coral formation commenced; and that by its continued growth at the summit, at a rate equal to that of the subsidence of its base, the platform has been kept up to the sea-level. The slight elevation which has raised its highest portion above that level may not improbably have taken place in connection with the much larger recent elevations already referred to.

Thus, then, we have evidence of considerable recent local modifications in the level of the Atlantic sea-bed, without any such change as would affect its general character as an ocean basin; while all geological probability seems in favour of the remoteness of the principal depression of the Atlantic area, even if we do not regard it as dating back to the period when the surface of the globe was first undergoing solidification.

*Currents of the Atlantic.*—By the term "current" will be here meant that sensible movement of ocean water in particular directions which can be generally traced, directly or indirectly, to the action of wind upon its surface. A

current thus directly impelled by wind is termed a "drift-current," whilst a current whose onward movement is sustained by the *vis a tergo* of a drift-current is called a "stream-current." But there is another source of current-movement, which has been overlooked by most writers on this subject, namely, the indraught which necessarily takes place to keep up the level of any area from which the surface-water is constantly being drifted away. Such currents, which may be designated as "indraught" or "supply currents," complete the "horizontal circulation" that must necessarily take place in any oceanic area of which one part is subjected to the action of a wind almost constantly blowing in the same direction. Of such a circulation we have a very characteristic example in the South Atlantic, the principal currents of which we shall see to be very easily accounted for.

The initial movement of the current-system, alike of the North and of the South Atlantic, is given by the trade-winds, which are continually driving the water of the inter-tropical region from the African towards the American side of the basin, so as to produce what is known as the *Equatorial Current*. The position of the northern and southern boundaries of this current shifts, like the area of the trade-winds, in accordance with the northward and southward declination of the sun;—a steady westward drift being generally met with to the north of the tropic of Cancer in the summer of the northern hemisphere, and to the south of the tropic of Capricorn in the summer of the southern, whilst in the winter of each hemisphere the border of the drift lies within the tropic of that hemisphere. But as the *thermal equator* lies from two to three degrees to the north of the *geographical equator*, the entire zone of the trade-winds, and of the Equatorial Current propelled by them, is wider on the northern than on the southern side of the latter; and while the northerly trade often reaches 30° N. in July, and rarely extends south in January within 2° or 3° of the geographical equator, the southerly trade does not extend farther than 25° S. in January, and generally crosses the equator in July, even extending occasionally as far as 5° N. As between the northerly and southerly trades there is a region of "equatorial calms," so there is a corresponding interval between the northern and southern divisions of the Equatorial Current; and in this interval there is a counter-current (resembling the "back-water" often to be noticed in a stream that is flowing rapidly past some obstacle, such as a vessel at anchor, or a projecting angle of a river-bank), that runs eastwards, sometimes with considerable velocity, towards the Bight of Biafra, which may be considered the "head-water" of the Equatorial Current. From the recent observations of Capt. Nares in the "Challenger," it appears that the Equatorial Current, like other drift-currents, is very shallow, its depth being not much greater than 50 fathoms. He estimates its rate at the surface to be about 0.75 miles per hour, or 18 miles per day, whilst at 50 fathoms it only moves at about half that rate.<sup>1</sup> Its surface temperature generally ranges between 75° and 80°; but the thermometer falls to 60° at a depth of little more than 100 fathoms,—the temperature of this belt of water, as will be hereafter shown, being kept down by the continual rising of polar water from below.

The Equatorial Current passes directly across the Atlantic towards the chain of the Antilles and the coast of South America; and as not only the whole of the northern division, but a considerable part of the southern, strikes the American coast-line to the north of the salient angle of Cape St Roque (about 5° S. lat.), the portion of the current which is deflected into the northern hemisphere is much greater than that which is turned to the southward. It is

a general fact, that where a current encounters any partial obstruction,—such as a coast-line meeting it obliquely, a narrowing of its channel, the lateral pressure of another current, or even that of a mass of stationary water,—its velocity increases; and so the portion of the Equatorial Current that is pressed to the northward by the coast-line between Cape St Roque and the mouth of the Orinoco (known in the first part of its course as the *Cape St Roque Current*, and afterwards as the *Guiana Current*) acquires a greatly augmented rate, running ordinarily at the rate of from 30 to 50 miles, and occasionally at a rate of 80 miles, in the 24 hours. Entering the Caribbean Sea, it is reinforced by the portion of the Equatorial Current which flows in between the Lesser Antilles; and it then passes westwards along the northern coast of South America, until it is deflected northwards by the coast-line of Central America, and driven between the peninsula of Yucatan and the western extremity of Cuba into the Gulf of Mexico, at the rate of from 30 to 60 miles per day. A portion of it passes direct to the N.E. along the northern shore of Cuba; but by far the larger part sweeps round the gulf, following the course of its coast-line, and approaches the coast of Cuba from the N.W. as a broad deep stream of no great velocity, seldom running at more than 30 miles per day. The reunited current, being met by the Equatorial Current from the outside, which is pressing to the west along the north coast of Cuba and between the Bahama isles, is deflected northwards through the passage termed the Florida Channel, which is bounded on the one side by the southern extremity of the peninsula of Florida, and on the other by the coast of Cuba and the Bahamas. The rate of movement of the powerful current that flows through this channel, henceforth known as the *Gulf Stream*, is considerably augmented in its narrowest part, which is also its shallowest; but although its velocity sometimes reaches 4 (nautical) miles per hour, or even more, its *average* rate through the whole year may be confidently stated at not more than 2 miles per hour, or 48 miles per day.<sup>2</sup>

The Gulf Stream current, however, does not by any means occupy the whole of the sectional area of the Florida Channel; for it is separated from the American coast by a band of cold water, which occupies about three-eighths of its total breadth of 40 miles, and which also dips under the outflowing current. The movement of the cold superficial band is perceptibly inwards, and that of the cold under-stratum is presumably so; and it is the opinion of the American surveyors that the depth of the warm outward current is not more than one-third of that of the channel through which it flows. It is probable that the rate of movement decreases from the surface downwards; but upon this point we have as yet no certain information. The meaning of the cold inflow will hereafter become apparent.

The course taken by the Gulf Stream in the first instance is nearly parallel to the line of the United States coast, from which it is everywhere separated by a band of cold water,—the boundary line between the two being so distinct as to be known as the "cold wall." It does not show for some time any great disposition to spread itself out laterally, though a division into alternate bands of warmer and colder water, the cause of which seems to lie in the contour of the bottom of the Florida Channel, becomes perceptible before it reaches Charleston, and is very marked off Cape Hatteras. The Stream there presents the form of a fan, its three warm bands spreading out over the Atlantic surface to an aggregate breadth of 167 miles,

<sup>2</sup> This statement, which is much lower than that adopted by most writers on the Gulf Stream, is based on the entire aggregate of observations collected by the Meteorological Department, which further show that, for six months of the year, the monthly mean averages only 1.4 miles per hour, or 34 miles per day, whilst for the other six months it only averages 2½ miles an hour, or 60 miles per day.

<sup>1</sup> Mr Laughton, however, states the average velocity to be between 30 and 30 miles per day.

whilst two cold bands of an aggregate breadth of 53 miles are interposed between them. The innermost warm band is the one which exhibits the highest temperature and greatest rate of flow its velocity being greatest where it is pressed on laterally by the Arctic Current, so that a rate of 4 miles per hour is occasionally observed. Capt. Nares estimates the depth of the Stream in this part of its course at about 100 fathoms, and its rate of flow in the line of most rapid movement at 3 miles per hour. The outermost band, on the other hand, graduates insensibly, both as to temperature and rate of movement, into the general surface-water of the Atlantic. It is when passing Sandy Hook that the Gulf Stream takes its decided turn eastwards.—this change in its direction being partly due to the eastward bend of the United States coast-line, and partly to the excess of easterly momentum which it brings from the lower latitude in which it issued from the Florida Channel. Its general rate of flow past Nantucket seems not to exceed 1 mile per hour, and to be frequently less; but several degrees to the eastward of this, the current has been found occasionally running at the rate of 4 miles an hour,—this acceleration being probably due to the lateral pressure of the Arctic Current, which, during the early months of the year, is driven southwards at the rate of 10 or 12 miles per day by the N. and N.W. winds then prevailing along the coast of Labrador, and which, turning westwards round the south of Newfoundland, keeps close to the coast of the United States (being left behind in the rotation of the earth, in consequence of its deficiency of easterly momentum), and follows it southwards, everywhere separating it from the Gulf Stream.

By the gradual thinning-out and expansion of the Gulf Stream after passing the Banks of Newfoundland, by the progressive reduction of its rate of movement, and by the loss of that excess of temperature which previously distinguished it, as well as of its peculiar blue colour (which probably depends on its holding in suspension the finest particles of the river-silt brought down by the Mississippi), this remarkable current so far loses all its special attributes, as to be no longer recognisable to the east of the meridian of 30° W. long.,—there degenerating into the general easterly drift of that region of the Atlantic which is kept up by the prevalence of westerly winds, sometimes called "anti-trades." Where the Florida Current or true Gulf Stream can last be distinctly recognised, it forms a stratum not more than 50 fathoms in thickness; and it is there flowing almost due east, at a rate which would require about 100 days to bring it to the Land's End. The only valid evidence of the extension of any part of it to the western shores of Europe (the amelioration of their temperature being otherwise accounted for, while the transport of trunks of trees, drift-timber, fruits, shells, &c., to the Western Hebrides, the Orkney, Shetland, and Faroe islands, and the coast of Norway, may be fairly set down to the surface-drift sustained by the prevalence of S.W. winds) is afforded by the variable current known as *Remnell's*, which, flowing eastwards into the southern part of the Bay of Biscay, is deflected in a N.W. direction by the trend of its coast-line, so as to cross the British Channel towards the Scilly Islands, whence it passes to the S.W. coast of Ireland, its strength mainly depending on the continued prevalence of the westerly anti-trades. (See Plate L.)

Of the whole mass of water, on the other hand, that is brought into the mid-Atlantic by the Gulf Stream, it may be stated with confidence that the larger proportion turns southward to the east of the Azores, and helps to form the *North African Current*; the other tributary of which may be considered as originating as far north as Cape Finisterre, under the influence of the northerly winds which prevail

along the coast of Portugal. As this current flows past the entrance to the Strait of Gibraltar, a part of it, forming what is known as the *Gibraltar Current*, is drawn in to keep up the level of the Mediterranean, which would otherwise be reduced by the excess of evaporation from its surface; but the greater part keeps its course southwards along the Marocco coast, reinforcing the south-flowing extension of the Gulf Stream. On arriving at the border of the northerly trade, the *North African Current* divides into two parts,—the western division being at once carried into the course of the equatorial drift, whilst the eastern, which may be considered as essentially an indraught or supply current, follows the African coast-line, and turns eastward into the Gulf of Guinea, forming the *Guinea Current*, which, coalescing with the eastward "back-water" already mentioned, flows pretty constantly, sometimes with considerable rapidity, towards the Bight of Biafra. There it meets the *South African Current*, which forms the other great feeder of the Equatorial Current; and the circulation thus completed may be considered as recommencing from this "head-water." The large area of comparatively still water which lies in the interior of this North Atlantic circulation is called the *Sargasso Sea*,—a corruption of the name (*Mar de Sargazo*) which it received from Columbus and the early Spanish navigators, on account of the quantity of sea-weed that floats on its surface. The boundaries of this area, which is of an irregularly elliptical shape, and nearly equals that of Continental Europe, are somewhat variable; but it may be considered to lie between the parallels of 20° and 35° N., and between the meridians of 30° and 60° W. Into it is collected a large proportion of the drift or wreck which floats about the North Atlantic.

Proceeding now to the South Atlantic, we meet with a circulation of the same kind, uncomplicated by any embaying of the Equatorial Current. The smaller division of this current which strikes the coast of South America to the south of Cape St Roque flows along the coast of Brazil at the rate of from 12 to 20 miles a day, forming the *Brazil Current*, which, however, is separated from the land by an intervening band of lower temperature, that has, during the winter months, a distinct flow towards the equator. The *Brazil Current* can be traced southwards, by its temperature rather than by its movement, as far as the estuary of the La Plata, before reaching which, however, a great part of it takes an easterly direction, and crosses the Atlantic towards the Cape of Good Hope, forming what is known as the *Southern Connecting Current*. The easterly movement of this current seems to be partly due to the westerly anti-trades, and partly to the excess of easterly momentum which is retained by the *Brazil Current* in its southward course from Cape St Roque; whilst it partly depends also on the junction of an Antarctic current that flows N.E. from Cape Horn, meeting the *Brazil Current* off the estuary of La Plata, just as the Arctic Current meets the Gulf Stream off Newfoundland,—dense fogs being produced, in the one case as in the other, through the precipitation of the vapour overlying the Equatorial Current, by the colder air that overlies the Polar. On meeting the coast of South Africa, the *Southern Connecting Current* turns northwards, and runs towards the Bight of Biafra, forming the *South African Current*, the movement of which is partly sustained by the southerly winds which prevail along that coast, but is partly attributable to the indraught set up to supply the efflux of the Equatorial Current. In its passage thither, however, the part of it most distant from the land is draughted westwards by the southern trade, forming the most southerly portion of the equatorial drift. Between this and the *Southern Connecting Current* is a central space, lying between the



parallels of 20° and 30° S., and the meridians of 0° and 25° W., over which there are no regular currents; and to this the name Sargasso Sea is sometimes applied by analogy, although its surface has no covering of sea-weed. (See Plate I.)

*Temperature of the Atlantic.*—The distribution of surface temperature over the area of the Atlantic has now been made out with considerable accuracy; and it corresponds closely with what has been already stated as the course of the surface currents. There is, of course, a seasonal change, alike in its northern and in its southern division, this change being more and more marked as we recede from the equator. Following the course of the mean annual isotherms, however, we find that they cross the South Atlantic at nearly regular intervals, in an east and west direction, the principal departure from that direction being shown at their western end in the bend they take towards the south under the influence of the warm Brazil Current, and at their eastern in the still stronger bend they take towards the north under the influence of the cold South African Current, which reduces to about 75° the temperature of the southern equatorial that flows alongside the Guinea Current, whose temperature is 82°. In the North Atlantic, however, the influence of the movement of oceanic water on the surface-temperature is very much more marked. The annual isotherms, which cross the Sargasso Sea with nearly regular parallelism, and on the African side tend somewhat to the south, where they meet the colder water of the North African Current, show a strong northward bend on the American side, along the early course of the Gulf Stream; but as its excess of temperature above that of the Atlantic generally diminishes as we trace it towards the Banks of Newfoundland, this northward deflection progressively becomes less. The marked contrast in temperature which is often there exhibited between two contiguous bands of water,—a thermometer hanging from a ship's bow showing a temperature of 70°, whilst another hanging from the stern shows only 40°,—is due not so much to the elevation produced by the Gulf Stream as to the depression produced by the Arctic Current. This depression manifests itself in the southward bend given, on the American side, alike to the summer and the winter isotherms (see Plate), beyond the summer isotherm of 70° and the winter isotherm of 60°, which may be considered as having nearly their normal position; whilst the northward tendency of these same isotherms on the European side not less conspicuously indicates a flow of warm water towards the western coasts of the British Isles, Norway, and even Iceland and Spitzbergen. It has been customary to regard this flow as an extension of the Gulf Stream; but if that term be limited (as it ought) to the current that issues from the Gulf of Mexico through the Florida Channel, the hypothesis is found to be untenable so soon as the thermal phenomena of that current are carefully examined. For, in the first place, the popular idea that the Gulf Stream retains its high temperature with little diminution during its passage first northwards and then eastwards is clearly disproved by observation, as is shown by the following table of average temperatures taken at different seasons in the warmest of its bands:—

	Latitude.	Winter.	Spring.	Summer.	Autumn.
Florida Channel.....	25 N.	77	78	83	82
Off Charlestown .....	33 N.	75	77	82	81
Off Cape Hatteras .....	35 N.	72	73	80	76
S. E. of Nantucket Shoals	35 N.	67	68	80	72
S. of Nova Scotia .....	38 N.	62	67	78	69

From this it appears that, while the high surface-tempera-

ture with which the Gulf Stream leaves the Florida Channel is retained in summer, with only 5° reduction as far as Nova Scotia, there is a reduction of 5° in winter during its northward passage to Cape Hatteras, and a further reduction of no less than 10° during its eastward passage from Cape Hatteras to Nova Scotia, making a total reduction of 15°. In spring, again, there is a total reduction of 11°, and in autumn of 13°; and in both cases the reduction during the eastward flow under the parallel of 35° N. is greater than the reduction in the northward flow from 25° N. to 35° N. The explanation of this is plainly to be found in the fact that in the early part of the course of the Gulf Stream its superheated stratum is a thick one, so that when its superficial film is cooled down by a superincumbent atmosphere of lower temperature, it is replaced by the uprising of a deeper stratum having nearly its original temperature. But as the stream spreads out superficially, its superheated stratum becomes proportionally thinner, and will consequently be more and more rapidly cooled down by the superincumbent atmosphere. Even supposing, therefore, that it were not subjected to any special cooling influence, it appears certain that, as the rate of the current slackens and its depth diminishes, the cooling process must continue at an increased rate, so as to bring down the surface-temperature of the stream to the normal isotherm of the locality, long before it could reach the shores of Europe. But it has been shown that when it passes Newfoundland the Gulf Stream is subjected to a special cooling influence—that of the Labrador Current with its fleet of icebergs, which melt away when borne into it; and this produces such an immediate reduction of its surface-temperature, that it thenceforth shows very little excess, although its sub-surface stratum still appears to be warmer than that of the ocean through which it flows.

But, further, the Gulf Stream, where it is last recognisable as a current, is flowing due east, and its southern portion turns first south-east and then south, whilst, on the other hand, the course of the isothermal lines (see Plate) clearly shows that the flow of warm water which carries them northward spreads across the whole breadth of the Atlantic, from the British Isles to Labrador, even extending up to the west of north into Rafin's Bay. When we contrast this immense body of north-moving water with the thinned-out film of what is by comparison a mere rivulet, it becomes obvious (1) that its northward flow cannot be attributable to the *vis a tergo* of the Florida Current, whilst (2) its convection of heat to the Arctic Sea cannot be accounted for by any amount of excess of temperature that is limited to a small depth, since the temperature of such a stratum, moving north-east at a rate of (at most) 4 or 5 miles per day, must soon be brought down to that of the atmosphere above it.

Influenced by these considerations, several eminent hydrographers, both British and American, have been disposed to deny, not only that the temperature of the North Atlantic is modified in any considerable degree by the true Gulf Stream, but that any other agency than that of warm S.W. winds is concerned in producing the climatic amelioration popularly attributed to it. They maintained, in fact, that the surface-temperature of the North Atlantic and Arctic Seas follows that of the superincumbent air,—the atmospheric temperature not being in any degree raised by that of warmer water beneath. This doctrine, however, is found to be inconsistent with the results of careful comparisons recently instituted between marine and atmospheric temperatures along the western coasts of Scotland, the Orkney, Shetland, and Faroe Islands, and especially with those obtained along the western coast of Norway. For it is found that during the winter months there is a constant excess of sea-temperature above that of the air, averaging

6°·2 Fahr. along the western coast of Scotland and its islands, and rising to 14°·5 at Fruholm near the North Cape. And it is also a very significant fact (ascertained by the careful inquiries of Mr Buchan), that while the *summer* isotherms cross the British Islands nearly east and west (the temperature diminishing pretty regularly from south to north), the *winter* isotherms traverse them nearly north and south (the temperature, diminishing from west to east); whilst in Ireland the isotherms seem to envelope the islands in their folds, which increase in warmth from the centre of the island to its sea-board. So in Norway the isothermal lines run parallel to the coast-line, and this alike in summer and in winter,—the temperature falling in winter, and rising in summer, with the increase of distance from the sea. Nothing could prove more conclusively than such facts as these (taken in connection with the absence of ice in the harbours of Norway, even as far north as Hammerfest, through the whole winter) the dependence of the mild winter climate of the north-western coasts of Europe upon the proximity of a sea which is warmer than the superincumbent atmosphere; and we have now to inquire how this great N.E. movement of a stratum of warm water sufficiently thick to retain a surface-temperature considerably higher than that of the air above it is to be accounted for.

The solution of the problem seems to be afforded by the doctrine of a *General Oceanic Circulation*, sustained by opposition of temperature only, which was first distinctly propounded in 1845 by Professor Lenz of St Petersburg, on the basis of observations made by him during the second voyage of Kotzebue (1825–1828). Others had been previously led to surmise that “Polar Currents” flow along the floors of the great oceans, even as far as the equator, balancing the superficial counter-currents which are observable in the opposite direction. But Lenz was led to conclude that the whole of the deeper portion of the great ocean-basins in communication with the polar areas is occupied by polar water, which is constantly, though slowly, flowing towards the equator; whilst conversely the whole upper stratum of equatorial water is as constantly, though slowly, flowing towards one or both of the poles. And he particularly dwelt on the existence of a belt of water under the equator, colder than that which lies either north or south of it, as an evidence that polar water is there continually rising from beneath towards the surface,—a phenomenon which, he considered, admits of no other explanation. He further adduced the low salinity of equatorial water (previously noticed by Humboldt, and confirmed by his own observations), compared with that of tropical water, as evidence that the equatorial water of the surface is derived from the polar underflow. And he attributed the maintenance of this circulation to the continually renewed disturbance of equilibrium between the polar and equatorial columns,—the greater lateral (because downward) pressure of the former<sup>1</sup> causing a *bottom outflow* of polar water in the direction of the latter, whilst the reduction of level thus occasioned will produce a *surface indraught* from the warmer towards the colder areas.

The doctrine of Lenz, so far from meeting with the general acceptance to which it had a fair claim,—alike on theoretical grounds and from its accordance with the facts ascertained by careful observation,—seems to have been put aside and forgotten, a preference being given to the doctrine of the prevalence of a uniform deep-sea temperature of 39°, which was supposed to be established by the

<sup>1</sup> It must be borne in mind that sea water does not expand like fresh water in cooling below 39°·2, but continues to contract down to its freezing point, which lies between 27° and 25° Fahr., according as it is still or agitated.

thermometric observations made in the voyages of D'Urville and Sir James Ross. No such precaution was taken, however, in these observations as that to which Lenz had recourse, to obviate the effects of the tremendous pressure (1 ton per square inch for every 800 fathoms of depth) to which deep-sea thermometers are exposed; and it is now certain that the temperatures at great depths recorded by D'Urville and Ross were several degrees too high.

It was in entire ignorance of the doctrine of Lenz, and under the influence of that of D'Urville and Ross, which had been stamped with the great weight of Sir John Herschel's weight of authority,<sup>2</sup> that Dr Carpenter commenced in 1868 (in concert with Professor Wyville Thomson) a course of inquiry into the thermal condition of the deep sea, which at once convinced him of the fallacy of the uniform 39° doctrine, and led him to conclusions essentially accordant with those of Lenz. For in the channel of from 500 to 600 fathoms' depth between the north of Scotland and the Faroe Islands, they found the deeper half to be occupied by a stratum of glacial water, whose temperature ranged downwards from 32° to 29°·5; whilst the upper half was occupied by a stratum warmer than the normal temperature of the latitudes. This phenomenon was interpreted by Carpenter as indicating a deep glacial flow from N.E. to S.W., and a warm upper flow from S.W. to N.E.; and finding that to the west of this channel, on the border of the deep Atlantic basin, the excess of warmth extended to a depth of more than 500 fathoms, he came to the conclusion that the north-moving stratum which brought it could not be an extension of the true Gulf Stream, but must be urged on by some much more general force. A series of temperature-soundings taken along the west of Ireland, the Bay of Biscay, and the coast of Portugal, confirmed him in this view, by showing that the division between an upper warm stratum and a cold under-stratum exists in the North Atlantic at a depth of from 700 to 900 fathoms, the whole mass of water below this having either flowed into the basin from the polar area, or having had its temperature brought down to from 39° to 36°·5 by mixture with the polar inflow. And this conclusion was confirmed by the result of temperature-soundings taken at corresponding depths and under the same parallels of latitude in the Mediterranean; for as they showed a uniform temperature of from 54° to 56°, from beneath the stratum of 100 fathoms that was superheated by direct insolation, to the very bottom, it became clear that depth *per se* could have no effect in reducing the bottom-temperature; and that the cause of the excess of temperature in the mass of water occupying the Mediterranean basin above that of Atlantic water at the same depths, lies in the seclusion of the former from the polar underflow which brings down the deep temperature of the latter. This conclusion having received marked confirmation from temperature-soundings taken in the Eastern seas, was put forward by Carpenter as justifying the doctrine of a *vertical* oceanic circulation sustained by opposition of temperature only, quite independent of and distinct from the *horizontal* circulation produced by wind,—which doctrine he expressed in terms closely corresponding with those that had been used by Lenz. And the collection of data for the establishment or confutation of this doctrine was one of the objects of the “Challenger” expedition, which has already made, in the determination of the thermal stratification of the Atlantic between 38° N. lat. and 38° S. lat., what may be fairly characterised as the grandest single contribution ever yet made to terrestrial physics.

The following are the most important of the facts thus

<sup>2</sup> See his *Physical Geography of the Globe*, originally published in the eighth edition of this *Encyclopædia*.

established:—Of the water which fills the deep trough of the North Atlantic (fig. 1) between Tenerife (lat.  $28\frac{1}{2}^{\circ}$  N.) and St Thomas (lat.  $18\frac{1}{2}^{\circ}$  N.), divided by the "Dolphin rise" into an eastern and western basin, by far the larger

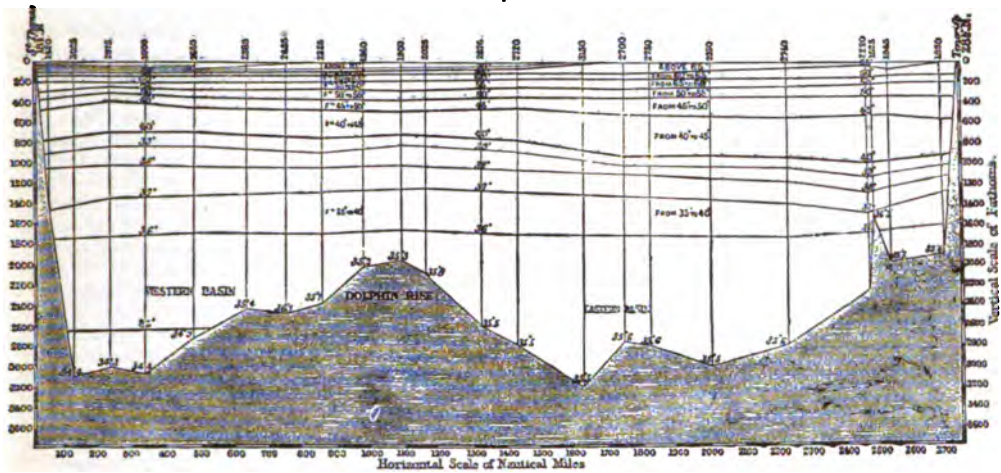

FIG. 1.—Section of North Atlantic Ocean between St Thomas and Tenerife.

mass has a temperature ranging from  $40^{\circ}$  downwards, in the eastern basin, to a bottom-temperature of  $35\frac{1}{2}^{\circ}$ , whilst in the western basin—apparently under the influence of the Antarctic underflow—the bottom-temperature sinks to  $34^{\circ}\cdot 4$ . A tolerably regular descent is shown in this section, from a surface-temperature rising near St Thomas to  $75^{\circ}$ , to the bathymetrical isotherm of  $45^{\circ}$ , which lies between 400 and 600 fathoms' depth; there is then a stratum between  $45^{\circ}$  and  $40^{\circ}$ , of which the thickness varies from about 250 to 450 fathoms, the isotherm of  $40^{\circ}$  lying at between 750 and 1000 fathoms' depth, while below this, down to the bottom at between 2000 and 3000 fathoms, the further reduction to  $34^{\circ}\cdot 4$  is very gradual.

The same general condition prevails in the South Atlantic (fig. 2), between Abrolhos Island (lat.  $18^{\circ}$  S.) on the coast of Brazil, and the Cape of Good Hope (lat.

$34\frac{1}{2}^{\circ}$  S.), this trough also being divided into two basins by the elevation of the bottom which culminates in the island of Tristan da Cunha. The temperature of the water that occupies it, however, is lower through its whole vertical range than that of the North Atlantic. The stratification is nearly uniform from the surface downwards to the isotherm of  $40^{\circ}$ , which lies at from 300 to 450 fathoms' depth, the isotherms of  $39^{\circ}$  and  $38^{\circ}$  also lying within about 500 fathoms; there is then a slower reduction down to the isotherm of  $35^{\circ}$ , which lies between 1400 and 1800 fathoms; while the whole sea-bed is covered by a stratum of about 600 fathoms' thickness, whose temperature ranges downwards from  $35^{\circ}$  to  $33^{\circ}$ . The whole of this deepest stratum is colder than any water that is found in the corresponding portion of the North Atlantic, except near St Thomas

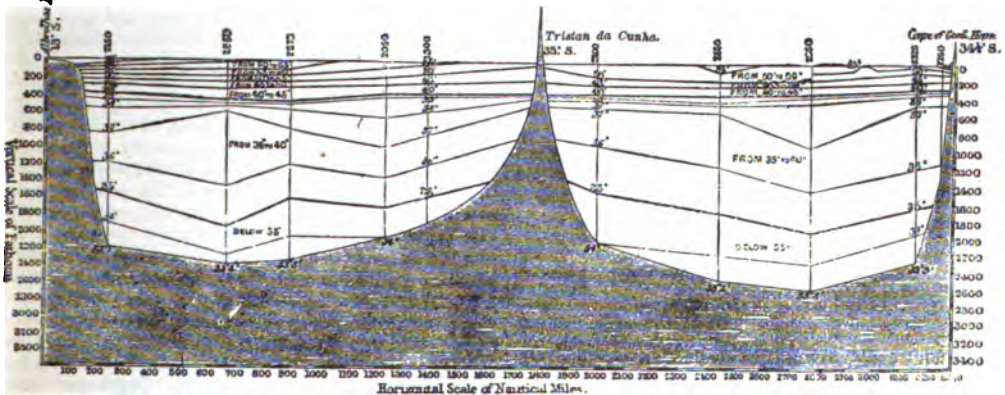

FIG. 2.—Section of South Atlantic.

It is not a little remarkable that the sub-surface stratum of water, having a temperature above  $40^{\circ}$ , is thinner under the equator than it is in any other part of the Atlantic from the Faroe Islands to the Cape of Good Hope. Notwithstanding the rise of the surface-temperature to  $76^{\circ}$ - $80^{\circ}$ , the thermometer descends in the first 300 fathoms more rapidly than anywhere else; so that polar water is met with, as shown in fig. 3, at a much less depth than in the

North Atlantic (fig. 1), and 100 fathoms nearer to the surface than even in the colder South Atlantic (fig. 2); whilst the temperature of the bottom is but little above  $32^{\circ}$ . Thus the influence of the polar underflow is more pronounced under the equator than it is elsewhere: as is distinctly seen in the section shown in fig. 4, which is taken in a north and south direction so as to exhibit the relation of the thermal stratification of the North to that

of the South Atlantic, and of both to that of the equatorial

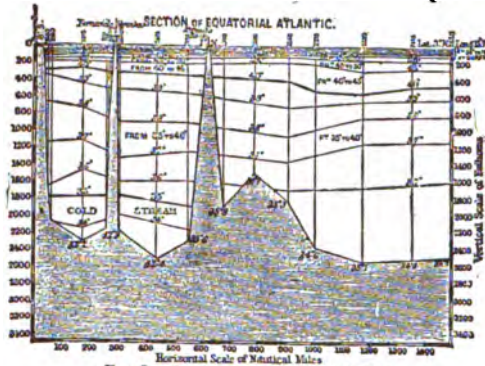

FIG. 3.—Section of Equatorial Atlantic.

belt. The isotherm of 40°, which in lat. 22° N. lies at a

depth of about 700 fathoms, gradually rises as the equator is approached; and it is between the equator and 7° S., where the surface-temperature rises to nearly 80°, that cold water is soonest reached,—the isotherm of 40° rising to within 300 fathoms of the surface, while that of 55°, which in lat. 38° N. lies at nearly 400 fathoms' depth, and in lat. 22° N. at about 250 fathoms, actually comes up under the equator within 100 fathoms of the surface. At the same time, while the bottom-temperature under the equator is the lowest anywhere met with, namely, 32° 4', the thickness of the stratum beneath the isotherm of 35° is not less than 600 fathoms. In passing southwards, the superficial isotherms are observed to separate again from each other, partly by the reduction of the surface-temperature, and partly by the descent of the isotherm of 40° to a depth of something less than 400 fathoms, which it keeps with little reduction as far south as the Cape of Good Hope. The significance of these facts becomes more remarkable, when we consider that if a portion of the oceanic area under the equator were to be secluded, like the Mediterranean or the

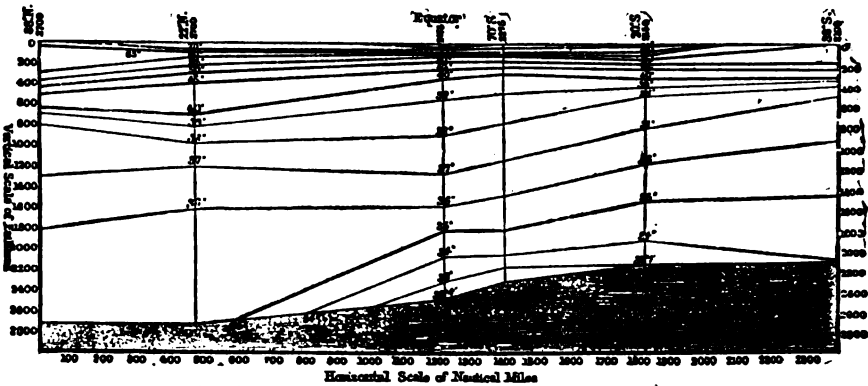

FIG. 4.—Section of Mid-Atlantic, taken nearly north and south.

Red Sea, from all but local influences, the temperature of its water from the sub-surface stratum downwards to the bottom—whatever its depth—would be its *isothermal* or mean winter-temperature, which, in the equatorial zone, would be certainly not below 75°.

Nothing, Dr Carpenter contends, could more conclusively support the general doctrine of a *Vertical Oceanic Circulation* sustained by opposition of temperature, than the precise conformity of the facts thus determined by observation to the predictions which his confidence in the theory had led him to put forth. These predictions were essentially as follows:—

"1. That instead of the local depressions of bottom-temperature imputed by previous writers to polar currents, the temperature of every part of the deep sea-bed in communication with either of the polar areas would be not many degrees above that of the polar areas themselves.

"2. That this general depression of bottom-temperature would be found to depend, not upon such a shallow glacial stream as might be maintained to be a return from the polar areas of water propelled towards them by wind-currents, but upon a creeping flow of the whole under-stratum, having a thickness of from 1000 to 2000 fathoms.

"3. That as the depression of bottom-temperature in any part of the general oceanic basin would be proportional to the freedom of communication between its deeper portion and that of one or other of the polar areas, the bottom-temperature of the South Atlantic would probably range downwards to 32°, while that of the North Atlantic would not be below 35°, except where it first receives the Arctic flow, or comes under the influence of the Antarctic underflow, which would very probably extend itself to the north of the equator.

"4. That as the Arctic and Antarctic underflows must meet at or near the equator, whilst the surface-stratum is there continually being draughted off thence towards either pole, there would be a

continual ascent of glacial water under the line, showing itself by a nearer approach of cold water to the surface in the *inter-tropical* than in the *extra-tropical* zone."

It was further pointed out by Lenz, and more recently (in ignorance of his doctrine) by Carpenter, that additional evidence of such ascent is furnished by the low salinity of the surface-water of the equatorial belt corresponding with that of polar water. For, as was originally observed by Humboldt, then by Lenz himself, and subsequently by many other voyagers, the specific gravity of the surface-water of the Atlantic gradually increases as either tropic is approached from the polar side of its own hemisphere, reaches its maximum a little nearer the equator, and then rapidly diminishes, coming down under the equator to the standard of polar water. Thus a mean of eight observations taken in the "Challenger" expedition between Bermuda (32° N.) and St Thomas (18½° N.) gave 1027.2 as the sp. gr. of *surface-water*, whilst a mean of seventeen observations between the Cape Verd Islands (16½° N.) and Bahia (13° S.) gave a sp. gr. of only 1026.3. Now, since between St Thomas and Bermuda the eight "Challenger" observations of *bottom* (polar) water gave a mean sp. gr. of 1026.3, whilst between Cape Verd and Bahia the mean sp. gr. of the *bottom-water* was even slightly lower (the results being

<sup>1</sup> That the bottom-temperature beneath the equator was lower than any that was met with in the South Atlantic, is attributable to the circumstance that, in consequence of unfavourable weather, the temperature-soundings were taken at intervals too wide to detect the deep channel through which the *coldest* Antarctic water doubtless flowed towards the equator.

in all cases expressed according to a common standard of temperature), such a close conformity subsists between the salinity of the equatorial water of the surface and that of the polar waters of the bottom, as can scarcely be accounted for in any other way than by the continual and tolerably rapid ascent of the latter.

Another indication of this ascent is given by the moderation of the surface-temperature of oceanic water, even under the equator. If there were no ascent of colder water from beneath, there seems no reason why the constant powerful insolation to which equatorial water is subjected should not raise the temperature of its surface to the highest possible elevation. The limit to that elevation, which is obviously set by the cooling influence of evaporation, is probably that which is met with in the Red Sea, where the monthly average for August rises to  $86\frac{1}{2}^{\circ}$  and for September to  $88^{\circ}$ , whilst the maxima rise much higher, temperatures of  $100^{\circ}$ ,  $106^{\circ}$ ,  $100^{\circ}$ , and  $96^{\circ}$  having been noted on four consecutive days. Moreover, along the Guinea Coast, and especially in the Bight of Biafra, the surface-temperature is stated to range as high as  $90^{\circ}$ . But in these cases there is no reduction of surface-temperature by the upward movement of polar water; for this is altogether excluded from the Red Sea by the shallowness of the Strait of Babelmandeb, whilst the depth of the bottom along the Guinea Coast is too small to allow of its being overflowed by the glacial stratum. Now, over the deeper parts of the equatorial Atlantic the surface-temperature usually ranges between  $75^{\circ}$  and  $80^{\circ}$ ; and this is its ordinary range in the Mediterranean during the months of August and September. That the temperature of an equatorial ocean should be thus kept down to that of a sea of which the greater part lies between the parallels of  $40^{\circ}$  and  $35^{\circ}$ , can scarcely be accounted for in any other way than by the continual uprising of polar waters from beneath.

The same principle, once admitted, fully accounts for that amelioration of the cold of north-western Europe, which (as already shown) cannot be fairly attributed to the Florida Current or true Gulf Stream. For it is obvious that a continual efflux of the lower stratum from the polar areas towards the equatorial must involve a continual indraught of the upper stratum towards the polar areas; and this indraught will be much more marked in the Northern than in the Southern Atlantic, on account of the progressive narrowing of the former, whilst the latter progressively widens out. Of such a slow northerly set of a stratum of water, extending downwards to a depth of at least 600 fathoms, we have evidence in a comparison of the temperature-soundings taken in the "Porcupine" expedi-

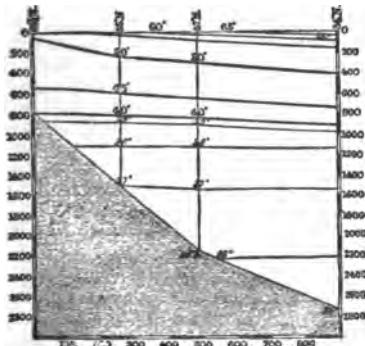

FIG. 5.—Section of North Atlantic, taken nearly north and south.

tions of 1869 and 1870, between the coast of Portugal ( $34^{\circ}$  N.) and the Faroe Islands ( $59\frac{1}{2}^{\circ}$  N.), from which the section fig. 5, has been worked out. For it is there

seen that, although the surface-temperature is reduced by the thinning-out of the superficial stratum, there is but a slight change in the position of the bathymetrical isotherms of  $45^{\circ}$  and  $40^{\circ}$ ; so that there is an obvious continuity of a stratum of many hundred fathoms' thickness between these two points, notwithstanding their separation by  $25\frac{1}{2}^{\circ}$  of latitude. The contrast between the position of the isotherm of  $40^{\circ}$  at 800 fathoms' depth off the Faroes, and its position at less than 300 fathoms' depth under the equator, is most remarkable. We have seen that the isotherm in the latter area would not be below  $75^{\circ}$ , and yet we find water colder than  $40^{\circ}$  lying at within 300 fathoms of the surface; whilst, on the other hand, the normal isotherm at  $59\frac{1}{2}^{\circ}$  N. would certainly be below  $40^{\circ}$  (probably no more than  $35^{\circ}$ ), and yet we find water above  $43^{\circ}$  extending downwards to 600 fathoms, and water above  $40^{\circ}$  to 800 fathoms. Thus the vertical oceanic circulation carries a vast mass of water which is below the normal off the coast of Portugal, into a region where it is above the normal, with very little loss of heat by the way, except in its surface-film; and a little consideration will show that such a movement must be much more effectual as a heater than a corresponding movement of a thin stratum of much warmer water. For the latter, when it passes beneath an atmosphere much colder than itself, will soon be brought down to a like standard, not having warmer water from below to take its place when it has been cooled down; whilst in the former, each surface-layer, when cooled below the temperature of the warmer stratum beneath, will sink and be replaced by it. Now since the true Gulf Stream, when we last know it, has been so thinned out that it could not long retain any excess of temperature, it seems inconceivable that it should exert any decided effect on the temperature of the Faroes and the coast of Norway, unless (as supposed by Dr Petermann and Professor Wyrville Thomson) its thickness undergoes an increase from less than 100 fathoms to 600. But since the course of Dr Petermann's isotherms shows that the northward flow extends across the whole breadth of the Atlantic between Newfoundland and the British Isles—a distance of about 2000 miles—we are required to believe that a rivulet (for such it is by comparison) of 60 miles' breadth and 100 fathoms' depth (see section, fig. 5), of which the greater part turns southwards round the Azores, and of which the remainder is flowing due east when we last recognise it, is able to impart a northerly movement to a stratum of 2000 miles in breadth, and at least 600 fathoms' depth. On the other hand, the eastward set of this stratum, considered as a northward indraught into the polar area, is readily accounted for by the excess of easterly momentum which it derives from the earth's rotation, this being only half as rapid in lat.  $60^{\circ}$  as it is under the equator; and since there is a still more rapid reduction in the rate of this rotation in yet higher latitudes, the continually increasing excess of easterly momentum will give to the northward flow a progressively stronger eastward set.

On the other hand, the deficiency of easterly momentum in the cold underflow coming from the pole towards the equator will tend to produce a lagging-behind, or westward set of that underflow; and this has been shown by the "Challenger" temperature-soundings to be the case,—the cold deep strata of the Western Atlantic surging upwards along the slope of the North American coast-line, as is shown in fig. 6, where we see not only the bathymetrical isotherms of  $60^{\circ}$ ,  $55^{\circ}$ , and  $50^{\circ}$ , but the yet deeper isotherms of  $45^{\circ}$  and  $40^{\circ}$ , successively rising to the surface as we approach the land; while at a depth of only 83 fathoms, a temperature of  $35^{\circ}$  was encountered, which, at no great distance to the south, would only be found at a depth of 2000 fathoms. That the cold water should thus run up-

hill is quite conformable to what we see in other cases, in which a heavier under-stratum has a definite set towards a slope; and whilst the existence of such a westerly set in, *ex hypothesi*, a necessary consequence of the southerly movement of the Arctic under-flow, no other explanation of it has been suggested. We now see that the cold Labrador Current overlies a band of water as cold as itself; and the southward extension of this cold band, far beyond that of any definite current - movement, and its

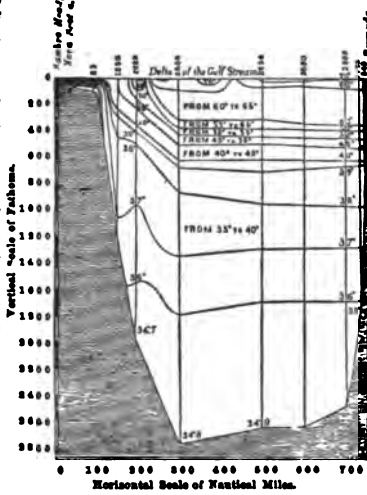

FIG. 6.—Section from Bermuda to Halifax.

entrance into the Gulf of Mexico, through the Florida Channel, at the side of and beneath the outflowing Gulf Stream, are thus accounted for.

The remarkable accordance of so many facts of actual observation, in the Atlantic area, with the probabilities deducible from a theory whose soundness can scarcely be disputed, seems now to justify the admission of the general (vertical) oceanic circulation sustained by opposition of temperature as an accepted doctrine of terrestrial physics.

*Distribution of Organic Life.*—All that will be attempted under this head will be to indicate the general conditions that seem, from recent researches, to have the greatest influence on the distribution of plants and animals through this great oceanic basin.

The distribution of marine plants seems mainly determined by light, temperature, and depth,—a further influence being exerted by the character of the shores. The diminution of light in its passage through sea-water is so rapid, that the quantity which penetrates to a depth of 250 or 300 fathoms may be regarded as almost infinitesimal; and in conformity with this we find a very rapid diminution of Algal life below the depth of 100 fathoms. The upper stratum is occupied for the most part by the larger and coarser forms of the *Fucacea*, or olive-green sea-weeds, whilst the more delicate *Ceramiacea*, or red sea-weeds, frequent deeper waters; and, as it appears from experiments made in aquaria that the latter do not flourish in full light, but grow well in shadow, it may be concluded that their preference for a moderate depth is rather for reduced light and stillness than for depth *per se*. At a depth of 150 fathoms very few ordinary sea-weeds maintain their ground; and below this we seldom find any Algae, save the Corallines and Nullipores consolidated by calcareous deposit. The distribution of particular types over different parts of the Atlantic area appears to be mainly regulated by temperature; and this would seem to be remarkably the case with the floating *Diatomacea*, which, though they form green bands in the surface-water of polar seas, have not been encountered in like abundance in the Atlantic, and do not contribute largely, by the subsidence of their siliceous *lorica*, to the composition of its bottom-deposit. Although it is the habit of the larger Algae to grow from a base of attachment (their roots serving no other purpose however,

than that of anchorage), the enormous mass of Gulf-weed found in the Sargasso Sea seems quite independent of any such attachment. It was at one time supposed that this originally grew on the Bahama and Florida shores, and was torn thence by the powerful current of the Gulf Stream; but it seems certain that if such was its original source, the "Gulf-weed" now lives and propagates whilst freely floating on the ocean-surface, having become adapted by various modifications to its present mode of existence.

The distribution of the animals that habitually live in that upper stratum of the ocean whose degree of warmth varies with the latitude, seems mainly determined by temperature. Thus the "right whale" of Arctic seas, and its representative in the Antarctic, seems never to enter the inter-tropical area, generally keeping away from even the temperate seas, whilst, on the other hand, the sperm-whale ranges through the parts of the ocean where the "right whales" are never seen.

The distribution of fishes seems generally to follow the same rule; as does also that of floating mollusks. Thus the little *Chio* (a Pteropod mollusk), which is a principal article of the food of the "right whales" in polar seas, is rarely met with in the Atlantic, where, however, other pteropods, as *Hyalaea*, present themselves in abundance. On the other hand, the warmer parts of its area swarm with Salpa-chains, which are not frequent in higher latitudes; and the few representatives of the Nautiloid Cephalopoda, that were so abundant in Cretaceous seas, are now restricted to tropical or sub-tropical areas. And the distribution of the mollusks, echinoderms, and corals, which habitually live on the bottom, seems to be determined, within certain limits at least, by temperature rather than by depth.

The bathymetrical range to which animal life of any higher type than the Rhizopodal might extend, was until recently quite unknown; but the researches initiated by Prof. Wyville Thomson and Dr Carpenter in 1868, and since prosecuted by the "Challenger" expedition, have fully established the existence of a varied and abundant fauna in ocean-depths ranging downwards to 2000 fathoms. And these researches have further established that the distribution of this fauna is mainly determined by the temperature of the sea-bed; so that whilst in the channel between the north of Scotland and the Faeroes there were found at the same depths, and within a few miles of each other, two faunas almost entirely distinct—one a boreal and the other a warmer-temperate—on sea-beds having respectively the temperatures of 30° and 43°, various types to which a low temperature is congenial are traceable continuously along the whole abyssal sea-bed that intervenes between those northern and southern polar areas within which they present themselves at or near the surface. And hence it becomes clear that, since glacial types are even now being embedded in the strata which are in process of formation beneath the equator, no inferences as to terrestrial climate can be drawn from the character of marine deposits.

One very remarkable feature which presents itself over a large proportion of the Atlantic basin is the abundance of the minute *Globigerina* and other Foraminifera, the accumulation of whose shells, and of their disintegrated remains, is giving rise to a calcareous deposit of unknown thickness, that corresponds in all essential particulars to Chalk. This deposit, in some parts of the North Atlantic, is replaced by an Arctic drift of fine sand, whilst in other parts there is a mixture of arenaceous and of calcareous components, such as is found in certain beds of the Cretaceous formation. Now on the surface of this deposit there have been found so many living types, especially belonging to the groups of Echinoderms, Corals, Siliceous Sponges, and Foraminifera, which closely correspond with types hitherto regarded as characteristic of the Cretaceous epoch, that the question naturally suggests itself whether

the existing are not the mutual descendants of the fossil types,—the differences they present being not greater than may be fairly attributed to the prolonged action of differences of temperature, food, pressure, &c. And when these facts are taken in connection with those previously stated as to the probable remoteness of the period when (if ever) the present sea-bed of the Atlantic was dry land, the doctrine first put forth by Prof. Wyville Thomson, that there has been a continuous formation of Globigerina-mud on the bottom of the Atlantic from the Cretaceous epoch to the present time—or, in other words, that the formation of chalk on the sea-bed of the Atlantic did not cease with the elevation of the European area, but has been going on through the whole Tertiary period,—must be admitted as (to say the least) a not improbable hypothesis. That some considerable change took place at the conclusion of the Cretaceous epoch, by which the temperature of the upper stratum was lowered, so as to be no longer compatible with the existence of the fishes and chambered cephalopods characteristic of the Cretaceous fauna, may be fairly assumed from their disappearance; but this would not so much affect the deeper part of the basin, in which those lower types that seem more capable of adapting themselves to changes in external conditions would continue to hold their ground. That the like conditions had prevailed also through long previous geological periods, may be surmised from the persistence, over various parts of the Atlantic sea-bed, of the *Apicrinis* type, which carries us back to the Oolitic formation, and of

the *Pentacrinus* type, which has come down with very little alteration from the Liassic; whilst many existing *Terebratulida* do not differ more from Oolitic types than the latter differ among each other. Going back still further, we find in the persistence of certain Foraminiferal types from the Carboniferous limestone to the present time, and in the character of its deep-sea beds, a strong indication that they originated in a Foraminiferal deposit, representing in all essential particulars that which is now going on; while the persistence of the *Lingula* from the early Silurian strata to the present time suggests the question whether certain oceanic areas may not have remained in the condition of deep sea throughout the whole subsequent succession of geological changes.

BIBLIOGRAPHY.—In addition to the ordinary sources of information, the following publications may be specially referred to for recent information in regard to the physical geography of the Atlantic:—"Reports of the Deep-Sea Explorations carried on in H.M. Steam-vessels 'Lightning,' 'Porcupine,' and 'Shearwater,'" in *Proceedings of the Royal Society* for 1868, 1869, 1870, and 1872; "On the Gibraltar Current, the Gulf Stream, and the General Oceanic Circulation," in the *Journal of the Royal Geographical Society* for 1871; and "Further Inquiries on Oceanic Circulation" (containing a summary of the "Challenger" Temperature Survey of the Atlantic), in the same journal for 1874; *Currents and Surface-Temperature of the North and South Atlantic*, published by the Meteorological Committee; and *The Depths of the Sea*, by Prof. Wyville Thomson. (w.s.c.)

ATLANTIS, ATALANTIS, or ATLANTICA, an island mentioned by Plato and other classical writers, concerning the real existence of which many disputes have been raised. In the *Timæus*, Critias relates how his grandfather Critias had been told by Solon some remarkable events in early Athenian history which he had learned from the Egyptian priests at Sais, whose records went much further back than the native accounts. "The most famous of all the Athenian exploits," Solon had been told, "was the overthrow of the island Atlantis. This was a continent lying over against the pillars of Hercules, in extent greater than Libya and Asia put together, and was the passage to other islands and to another continent, of which the Mediterranean Sea was only the harbour; and within the pillars the empire of Atlantis reached to Egypt and Tyrrhenia. This mighty power was arrayed against Egypt and Hellas and all the countries bordering on the Mediterranean. Then did your city bravely, and won renown over the whole earth. For at the peril of her own existence, and when the other Hellenes had deserted her, she repelled the invader, and of her own accord gave liberty to all the nations within the pillars. A little while afterwards there was a great earthquake, and your warrior race all sank into the earth; and the great island of Atlantis also disappeared in the sea. This is the explanation of the shallows which are found in that part of the Atlantic ocean."—(Jowett's *Introduction to the Timæus*.) Such is the main substance of the principal account of the island furnished by the ancients,—an account which, if not entirely fictitious, belongs to the most nebulous region of history. The story may embody some popular legend, and the legend may have rested on certain historical circumstances; but what these were it is (as the numerous theories advanced on the subject may be held as proving) impossible now to determine.

ATLAS (*Ἄτλας*), in *Greek Mythology*, called sometimes a son of Japetus and the nymph Asia, or of Uranus and Gaia, and at other times traced to a different parentage, but always known as the being who supported on his

shoulders the pillars on which the sky rested. He knew the depths of the sea (*Odyssey*, vii. 245), and in the first instance seems to have been a marine creation. The pillars which he supported were thought to rest in the sea, immediately beyond the most western horizon. But by the time of Herodotus (iv. 184), a mountain is suggested as best suited to hold up the heavens, and the name of Atlas is transferred to a hill in the N.W. of Africa. Then the name is traced to a king of that district, rich in flocks and herds, and owning the garden of the Hesperides. Finally, Atlas was explained as the name of a primitive astronomer. He was the father of the Pleiades and Hyades. Perseus encountered him when he searched for Medusa. Heracles took the burden of the sky from his shoulders, but cleverly contrived to replace it. Atlas bearing up the heavens is mentioned as being represented on early works of art, e.g., on the chest of Cypselus (Pausan., v. 18, 1), and on the throne of Apollo at Amyclæ (Pausan., iii. 18, 7); and this subject occurs on several existing works of art.

ATLAS, a mountain-chain of Northern Africa, between the great desert of the Sahara and the Mediterranean. The range has been but partially explored, and geographers differ as to its extent, some considering it to reach from Cape Ghir on the Atlantic to Cape Bon, the north-east point of Tunis, while others include under the name the whole mountain system between Cape Nun and the greater Syrtis. In this latter sense it forms the mountain-land of the countries of Morocco, Algeria, Tunis, and Tripoli. It is composed of ranges and groups of mountains, enclosing well-watered and fertile valleys and plains, and having a general direction from W. to E. The highest peaks are supposed to attain an elevation of nearly 15,000 feet; and although none of them reach the height of perpetual snow, some of their loftiest summits are covered with snow during the greater part of the year. Mount Miltain, 27 miles S.E. of the city of Morocco, was ascertained by Captain Washington to be 11,400 feet high. The greatest heights are in Morocco, from which point they appear to diminish in

elevation as they extend towards the E. These mountains, except the loftier summits, are, for the most part, covered with thick forests of pine, oak, cork, white poplar, wild olive, and other trees. The inferior ranges seem to be principally composed of Secondary limestone, which, at a greater elevation, is succeeded by micaceous schist and quartz-rock; and the higher chains are said to consist of granite, gneiss, mica-slate, and clay-slate. The Secondary and Tertiary formations are frequently disturbed and upraised by trap-rocks of comparatively modern date. Lead iron copper, antimony, sulphur, and rock-salt occur

frequently; and in the Marocco portion of the range gold and silver are said to exist. In the Algerian division are mines of copper, lead, silver, and antimony. The lion, hyena, boar, and bear are common throughout the mountains. None of the rivers which take their rise in the system are of any great importance. The Taflet is absorbed in the sands; the Tensaif and Draa flow into the Atlantic; and about five or six find their way to the Mediterranean. Dr Hooker has explored the botany of many parts of the range, and the travels of Bohlfs have added largely to our general knowledge of it.

## A T M O S P H E R E

**A**TMOSPHERE is the name applied to the invisible elastic envelope which surrounds the earth, the gaseous matter of which it is composed being usually distinguished by the name of air. Storms and weather generally, solar and terrestrial radiation, the disintegration of rocks, animal and vegetable life, twilight, and the propagation of sound, are some of the more striking phenomena which are either to a large extent or altogether dependent on the atmosphere. That air possesses weight may be shown by the simple experiment of taking a hollow globe filled with air and weighing it; then removing the contained air by means of an air-pump, and again weighing the globe, when it will be found to weigh less than at first. The difference of the two results is the weight of the air which has been removed. From Regnault's experiments, 100 cubic inches of dry air, or air containing no aqueous vapour, under a pressure of 30 English inches of mercury, and at a temperature of 60° Fahr., weigh 31.03629 grains; and since 100 cubic inches of distilled water at the same pressure and temperature weigh 25.252½ grains, it follows that air is 813.67 times lighter than water.

Air as an elastic fluid exerts pressure upon the earth or any substance on which it rests, the action of a boy's sucker and of a water-pump being familiar instances showing the pressure of the atmosphere. When air is removed from a water-pump, the water rises in the pump only to a certain height; for as soon as the water has risen to such a height that the weight of the column of water in the pump above the level of the surface of the water in the well just balances the pressure exerted by the atmosphere on the surface of the well, it ceases to rise. If the pressure of the atmosphere be increased, the water will rise higher in the pump; but if diminished, the level of the water will sink. The height to which the water rises within the pump thus varies with the pressure of the atmosphere, the height being generally about 34 feet. Since a given volume of mercury weighed *in vacuo* at a temperature of 62° Fahr. is 13.569 times heavier than the same volume of water, it follows that a column of mercury will rise *in vacuo* to a height 13.569 times less than a column of water, or about 30 inches. If we suppose, then, the height of the mercurial column to be 30 inches, which is probably near the average height of the barometer at sea-level, and its base equal to a square inch, it will contain 30 cubic inches of mercury; and since one cubic inch of mercury contains 3426.7 grains, the weight of 30 cubic inches will be nearly 14.7304 lb *avoirdupois*. Thus the pressure of the atmosphere is generally, at least in these latitudes, at sea-level equal to 14.7304 lb on each square inch of the earth's surface. Sir John Herschel has calculated that the total weight of an atmosphere averaging 30 inches of pressure is about 11½ trillions of pounds; and that, making allowance for the space occupied by the land above the sea, the mass of such an atmosphere is about ~~very~~ part of that of the earth itself. This enormous

pressure is exerted on the human frame in common with all objects on the earth's surface, and it is calculated that a man of the ordinary size sustains a pressure of about 14 tons; but as the pressure is exerted equally in all directions, and permeates the whole body, no inconvenience arises in consequence of it.

A pressure agreeing approximately with the average atmospheric pressure at sea-level is often used as a unit of pressure. This unit is called an *atmosphere*, and is employed in measuring pressures in steam-engines and boilers. The value of this unit which has been adopted, in the metrical system, is the pressure of 760 millimètres (29.922 Eng. inches) of the mercurial column at 0° C. (32° Fahr.) at Paris, which amounts in that latitude to 1.033 kilogrammes on the square centimetre. In the English system, an *atmosphere* is the pressure due to 29.905 inches of the mercurial column at 32° Fahr. at London, amounting there to nearly 14½ lb weight on the square inch. The latter atmosphere is thus 0.99968 of that of the metrical system.

As regards the distribution of atmospheric pressure over the globe, there was little beyond conjecture, drawn from theoretical considerations and for the most part erroneous, till the publication in 1868 of Buchan's memoir "On the Mean Pressure of the Atmosphere and the Prevailing Winds over the Globe."<sup>1</sup> By the monthly isobaric charts and copious tables which accompanied the memoir, this important physical problem was first approximately solved. Since then the British Admiralty has published charts showing the mean pressure of the atmosphere over the ocean.<sup>2</sup> The more important general conclusions regarding the geographical distribution of atmospheric pressure are the following:—

There are two regions of high pressure, the one north and the other south of the equator, passing completely round the globe as broad belts of high pressure. They enclose between them the low pressure of tropical regions, through the centre of which runs a narrower belt of still lower pressure, towards which the north and south trades blow. The southern belt of high pressure lies nearly parallel to the equator, and is of nearly uniform breadth throughout; but the belt north of the equator has a very irregular outline, and great differences in its breadth and in its inclination to the equator,—these irregularities being due to the unequal distribution of land and water in the northern hemisphere. Taking a broad view of the subject, there are only three regions of low pressure,—one round each pole, bounded by or contained within the belts of high pressure just referred to, and the equatorial belt of low pressure. The most remarkable of these, in so far as yet known, is the region of low pressure surrounding the south pole, which appears to remain pretty constant

<sup>1</sup> *Trans. Roy. Soc. Edin.*, vol. xxv. p. 575.

<sup>2</sup> *Physical Charts of the Pacific, Atlantic, and Indian Oceans*, Lond. 1872.



during the whole year. The depression round the north pole is divided into two distinct centres, at each of which there is a diminution of pressure greatly lower than the average north polar depression. These two centres lie in the north of the Atlantic and Pacific Oceans respectively. The distribution of pressure in the different months of the year differs widely from the annual average, particularly in January and July, the two extreme months. In January the highest pressures are over the continents of the northern hemisphere,—and the larger the continental mass the greater the pressure,—and the lowest pressures are over the northern portions of the Atlantic and Pacific, South America and South Africa, and the Antarctic Ocean. In the centre of Asia the mean pressure of the atmosphere in this month is fully 30·400 inches, whereas in the North Atlantic, round Iceland, it is only 29·340 inches, or upwards of an inch lower than in Central Asia. The area of high barometer is continued westwards through Central and Southern Europe, the North Atlantic between 5° and 45° N. lat., North America, except the north and north-west, and the Pacific for some distance on either side of 15° N. lat. It is thus an exaggerated form of the high belt of annual mean pressure, spreading, however, over a much greater breadth in North America, and a still greater breadth in Asia.

In July, on the other hand, the mean pressure of Central Asia is only 29·468 inches, or nearly an inch lower than during January; or, putting this striking result in other words, about a thirtieth of the pressure of the atmosphere is removed from this region during the hottest months of the year as compared with the winter season. The lowest pressures of the northern hemisphere are now distributed over the continents, and the larger the continental mass the greater is the depression. At the same time, the highest are over the ocean between 50° N. and 50° S. lat., particularly over the North Atlantic and the North Pacific between 25° and 40° N. lat., and in the southern hemisphere over the belt of high mean annual pressure, which in this month reaches its maximum height. Pressure is high in South Africa and in Australia, just as in the winter of the northern hemisphere pressures are high over the continents.

Over the ocean, if we except the higher latitudes, atmospheric pressure is more regular throughout the year than over the land. In the ocean to westwards of each of the continents there occurs at all seasons an area of high pressure, from 0·10 inch to 0·30 inch higher than what prevails on the coast westward of which it lies. The distance of these spaces of high pressure is generally about 30° of longitude; and their longitudinal axes lie, roughly speaking, about the zones of the tropics. The maximum is reached during the winter months, and these areas of high pressure are most prominently marked west of those continents which have the greatest breadth in 30° lat.; and the steepest barometric gradients are on their eastern sides. It is scarcely possible to over-estimate the importance of these regions of high and low mean pressures, from their intimate bearing on atmospheric physics, but more particularly from their vital connection with prevailing winds and the general circulation of the atmosphere. This relation will be apprehended when it is considered that winds are simply the flowing away of the air from regions where there is a surplus (regions of high pressure) to where there is a deficiency of air (regions of low pressure). Everywhere over the globe this transference takes place in strict accordance with Buys-Ballot's "Law of the Winds," which may be thus expressed:—The wind neither blows round the space of lowest pressure in circles returning on themselves, nor does it blow directly toward that space; but it takes a direction intermediate, approaching, however, more

nearly to the direction and course of circular curves than of radii to a centre. More exactly, the angle is not a right angle, but from 45° to 80°. Keeping this relation between wind and the distribution of pressure in mind, the isobaric lines give the proximate causes of the prevailing winds over the globe, and through these the prominent features of climates. As regards the ocean, the prevailing winds indicate the direction of the drift-currents and other surface-currents, and thereby the anomalous distribution of the temperature of the sea as seen in the Chili, Guinea, and other ocean currents, and the peculiarly marked climates of the coasts past which these currents flow, are explained; for observations have now proved that the prevailing winds and surface-currents of all oceans are all but absolutely coincident.

As regards the annual march of pressure through the months of the year, curves representing it for the different regions of the earth differ from each other in every conceivable way. It is only when the results are set down in their proper places on charts of the globe that the subject can be well understood. When thus dealt with, many of the results are characterised by great beauty and simplicity. Thus, of all influences which determine the barometric fluctuation through the months, the most important are the temperature, and through the temperature the humidity. Comparing, then, the average pressure in January with that in July, which two months give the greatest possible contrasts of temperature, the following is the broad result:—

The January exceeds the July pressure over the whole of Asia except Kamtchatka and the extreme north-east, the greatest excess being near the centre of the continent; over Europe to south and east of a line drawn from the White Sea south-westward to the Naze, thence southward to the mouth of the Weser, then to Tours, Bordeaux, and after passing through the north of Spain, out to sea at Coruña; over North America, except the north-east and north-west. On the other hand, the July exceeds the January pressure generally over the whole of the southern hemisphere, over the northern part of the North Atlantic and regions immediately adjoining (the excess amounting in Iceland to 0·397 inch), and over the northern part of the North Pacific and surrounding regions. Thus the pressure which is so largely removed from the Old and New Continents of the northern hemisphere in July is transferred, partly to the southern hemisphere, and partly to the northern portions of the Atlantic and Pacific Oceans.

Atmospheric pressure is more uniformly distributed over the globe in April and October than in any of the other months. In May and November, being the months immediately following, occur the great annual rise and fall of temperature; and since these rapid changes take place at very different rates, according to the relative distribution of land and water in each region, a comparison of the geographical distribution of May with that for the year brings out in strong relief the more prominent causes which influence climate, and some of the more striking results of these causes. This comparison shows a diminution of pressure in May over tropical and sub-tropical regions, including nearly the whole of Asia, the southern half of Europe, and the United States. An excess prevails over North America to the north of the Lakes, over Arctic America, Greenland, the British Isles, and to the north of a line passing through the English Channel in a north-easterly direction to the Arctic Sea. The excess in the southern hemisphere includes the southern half of south America and of Africa, the whole of Australia, and adjacent parts of the ocean. The influence of the land of the southern hemisphere, which in this month is colder than the surrounding seas, brings about an excess of pressure; on the other hand, the influence of land over those regions

which are more immediately under the sun brings about a lower pressure, interesting examples of which occur in India, the Malayan Archipelago, and the Mediterranean, Black, and Caspian Seas. In many cases the lines of pressure follow more or less closely the contours of the coasta. Thus the diminution is greater over Italy and Turkey than over the Adriatic and Black Seas. The greatest diminution occurs in Central Asia, where it exceeds 0.200 inch, and the greatest excess round Iceland, where it exceeds 0.200 inch. It is to the position of Great Britain, with reference to the deficiency of pressure on the one hand and the excess on the other, that the general prevalence of east winds at this season is due. These easterly winds prevail over the whole of Northern Europe, as far south as a line drawn from Madrid and passing in a north-easterly direction through Geneva, Munich, &c. To the south of this line the diminution of pressure is less, and over this region the winds which are in excess are not easterly, but southerly. Crossing the Mediterranean, and advancing on Africa, we approach another region of lower pressure, towards which easterly and north-easterly winds again acquire the ascendancy, as at Malta, Algeria, &c.

This, in many cases great, variation of the pressure in the different months of the year must be kept carefully in view in deducing heights of places from observations made by travellers of the pressure of atmosphere, by the barometer or the temperature of boiling water. In reducing the observations, it is necessary to assume a sea-level pressure if the place is at a considerable distance from any meteorological observatory. Previous to the publication of Buchan's *Mean Pressure of the Atmosphere*, it appears that a mean sea-level pressure of 29.92 or 30.00 inches was in such cases universally assumed. The mean pressure at Barnaul, Siberia, being 29.536 inches in July, 30.293 inches in January, and 29.954 inches for the year, it follows that, by the former method of calculating the heights, observations made in January to ascertain the height of Lake Balkash would make the lake 350 feet too high, and observations made in July would make it 330 feet too low,—the difference of the two observations, each set being supposed to be made under the most favourable circumstances, and with the greatest accuracy, being 680 feet. This illustration will serve to account for many of the discrepancies met with in books regarding the heights of mountains and plateaus.

Of the periodical variations of atmospheric pressure, the most marked is the daily variation, which in tropical and sub-tropical regions is one of the most regular of recurring phenomena. In higher latitudes the diurnal oscillation is masked by the frequent fluctuations to which the pressure is subjected. If, however, hourly observations be regularly made for some time, the hourly oscillation will become apparent. The results show two maxima occurring from 9 to 11 A.M. and 9 to 11 P.M., and two minima occurring from 3 to 6 A.M. and 3 to 6 P.M. The following are the extreme variations for January, April, July, and October from the daily mean pressure at Calcutta, deduced from the observations made during six years, viz., 1857-62:—

	A.M.				P.M.			
	Min.	Hour.	Max.	Hour.	Min.	Hour.	Max.	Hour.
January .....	Inch. -0.028	3	Inch. +0.079	10	Inch. -0.053	4	Inch. +0.110	10
April .....	-0.020	3	+0.070	9	-0.071	4	+0.116	10
July .....	-0.119	3	+0.040	10	-0.061	4	+0.029	10
October .....	-0.026	3	+0.064	9	-0.047	4	+0.118	10

Similarly the maxima and minima at Vienna, with the hour of their occurrence, are as follows :

	A.M.				P.M.			
	Min.	Hour.	Max.	Hour.	Min.	Hour.	Max.	Hour.
January .....	Inch. -0.008	6	Inch. +0.118	10	Inch. -0.020	3	Inch. +0.112	10
April .....	-0.003	5	+0.211	10	-0.027	5	+0.114	11
July .....	+0.003	3	+0.023	9	-0.028	5	+0.009	11
October .....	-0.010	3	+0.020	10	-0.015	4	+0.008	10

These two illustrations may be regarded as typical, to a large extent, of the diurnal barometric oscillations in tropical and temperate regions. At Calcutta the amounts are large, and the dates of the occurrence of the maxima and minima very regular from 3 to 4 and 9 to 10 A.M. and P.M. respectively. On the other hand, the oscillations at Vienna are much smaller and more variable in amount, and the dates of occurrence of the critical phases take place through a wider interval, viz., from 3 to 6 and 9 to 11 A.M. and P.M. respectively.

Though the diurnal barometric oscillations are among the best-marked of meteorological phenomena, at least in tropical and sub-tropical regions, yet none of these phenomena, except perhaps the electrical, could be named respecting whose geographical distribution so little is really known, whether as regards the amount of variation, the hour of occurrence of the critical phases, or, particularly, the physical causes on which the observed differences depend. This arises chiefly from the want of a sufficient number of ascertained facts; and to remedy this deficiency, observations have, in the preparation of this present article, been collected and calculated from upwards of 250 places in different parts of the globe, and the data set down on charts. The chief results of this inquiry are the following, attention being entirely confined to the chief oscillation, viz., that occurring from the A.M. maximum to the P.M. minimum.

*The A.M. Maximum.*—In January this occurs from 9 to 10 in tropical and temperate regions as far as 50° N. lat.; in higher latitudes the time of occurrence varies from 8 A.M. to noon. In July it occurs from 9 to 10 everywhere only as far as about 40° N. lat.; the time at Tiflis (41° 42' N. lat.) being between 7 and 8 A.M. In higher latitudes the time varies from 8 to 11 A.M., the last hour being general in north-western Europe.

*The P.M. Minimum.*—In January this occurs from 3 to 4 P.M. nearly everywhere over the globe, a few exceptions occurring in north-western Europe, the extremes being 2 P.M. at Utrecht and 6 P.M. at St Petersburg. It is quite different in July, when the time from 3 to 4 P.M. is regularly kept as far north as about 40° N. lat. In higher latitudes the hour is very generally 5, but at some places it is as early as 4 P.M., and at others as late as 6 P.M.

In the northern hemisphere, in summer, the afternoon minimum falls to a greater extent below the mean of the day than the forenoon maximum rises above it, at 62 per cent. of the stations; but in winter the percentage is only 61. In the southern hemisphere the same relation is observed in the summer and winter months, thus showing that in the summer of both hemispheres the influence of the sun tends to lower the minimum at 3 to 4 P.M. to a greater extent than to raise the 9 to 10 A.M. maximum.

*Decrease between Morning Maximum and Afternoon Minimum.*—Of the four daily oscillations, this is the most important. When the amounts at different places are entered on charts of the globe, it is seen that the amplitude of this fluctuation is, speaking generally, greatest in the tropics, diminishing as we advance into higher latitudes; greater over the land than over the sea, increasing greatly on proceeding inland; nearly always greater with a dry than with a moist atmosphere; and generally, but by no means always, it is greatest in the month of highest

temperature and greatest dryness combined. The regions of largest amplitude include the East India Islands, Eastern Peninsula, India, Arabia, tropical Africa, and tropical South and Central America, where it either closely approaches or exceeds 0.100 inch. At Silchar, in Assam, it is 0.133 inch. In the tropical parts of the ocean the oscillation is from 0.020 to 0.030 inch less than on land. The influence of the Mediterranean Sea in lessening the amount over all regions bordering it is very strongly marked. The line showing an oscillation of 0.050 inch crosses North America about lat. 44°, curves southward at some distance from the east coast to lat. 23°, then north-eastward along the coast of Africa, passes eastwards near the north coast of that continent, thence strikes northwards, cutting the eastern part of the Black Sea, and eastward across the Caspian to a point to northward of Peking, and then bends southward to the Loo Choo Islands. The line of 0.020 inch cuts the N.W. of Spain and N.W. of France, and runs northward through Great Britain as far as the Tweed, thence to Christiania, then southwards to Copenhagen and to Cracow, the latitude of which it follows eastward through Asia.

The more marked seasonal changes are these:—In India the oscillations during the dry and wet seasons, or in January and July, respectively, are—Bombay, 0.120 and 0.067 inch; Poonah, 0.133 and 0.059 inch; and Calcutta, 0.132 and 0.091 inch. At Madras, where the rain-bringing characters of the monsoons are reversed, the numbers are 0.114 and 0.115 inch, and at Roorkee, where rain falls all the year round, 0.088 and 0.079. Again, at Aden, in Arabia, where the weather of July is peculiarly hot and dry, the oscillation in December is 0.106, but in July it rises to 0.137 inch. The point to be insisted on here is, that, whatever be the cause or causes to which the daily barometric oscillation is due, the absolute amount is largely dependent on comparatively local influences.

While illustrations similar to the above may be adduced from many other parts of the globe, showing the influence in the same direction of prevailing dry or wet, hot or cold seasons on the amplitude of the oscillation, the North Atlantic and regions adjoining present an apparent exception to the law which seems to be indicated by these results. The whole of the North Atlantic, particularly north of lat. 20°, and the sea-boards which bound it, to which the Mediterranean and its immediate sea-board may be added, are strikingly characterised by a small summer oscillation; and this diminution is most strongly marked along the eastern part of the ocean. Thus, in July, at Ponta Delgada, in the Azores, the oscillation is only 0.06 inch; at Angra do Heroísmo, also in the Azores, 0.010 inch; at Funchal, Madeira, 0.011 inch; at Oporto, 0.018; Lisbon, 0.030; and Lagos, 0.021; at Naples and Palermo, 0.008; and at Malta, 0.020 inch. Now, with reference to this extensive region, it is to be noted that the rainfall of July is either zero or very small; and yet with this dry state of the atmosphere and high temperature (the annual maximum occurring at the time), this oscillation is extraordinarily diminished, being exactly the reverse of what takes place during the dry and wet seasons in India. The diminution on the western half of the Atlantic, though not so great, is also striking, the January and July oscillations being 0.056 and 0.036 inch in Barbadoes, 0.080 and 0.056 at Jamaica, 0.082 and 0.054 at Havanna, 0.053 and 0.024 in the Bahamas, and 0.054 and 0.022 in Bermuda. Over the whole of the region here indicated the rainfall of July is largely in excess of that of January. The apparently exceptional character of this region is probably due to the circumstance, that at this time of the year the sun's rays fall perpendicularly over a more diversified surface of the earth, that is, on a greater extent of land, than at any other season. At this time the Mediterranean,

which is completely shut in by land, and the Atlantic, which is bounded by two great continents, show a much smaller oscillation than prevails over the land adjoining them, and the lines of equal oscillation now attain their annual maximum. On the other hand, in January, when the sun's rays fall perpendicularly over the most uniform surface, or over the maximum extent of ocean, the lines are almost everywhere parallel with the parallels of latitude.

Again, on advancing inland from the Atlantic, the effects of comparatively local influences are very striking, as the following mean July oscillations, from places situated in lines running in different directions, show:—Dublin, 0.012; Oxford, 0.022; Ostend, 0.009; Brussels, 0.019; Vienna, 0.049; Odessa, 0.024; and Tiflis, 0.077; Limerick, 0.010; Helston, 0.007; Paris, 0.020; Geneva, 0.045; Turin, 0.052; Rome, 0.036; Palermo, 0.008; and Malta, 0.020. But the most remarkable illustration is the following, the places being all situated between 38° and 42° N. lat.: San Francisco, 0.068; Fort Churchill, 0.091; Washington, 0.063; Angra do Heroísmo, 0.006; Lisbon, 0.030; Campo Maior, 0.054; Palermo, 0.008; Tiflis, 0.077; and Peking, 0.060.

It follows from what has been stated that much which has been written regarding these fluctuations, and in explanation of them, does not rest on facts; and nearly everything yet requires to be done in the way of collecting data towards the representation and explanation of the daily oscillations of atmospheric pressure which are, as regards two-thirds of the globe, perhaps, as already stated, the most regular of recurring phenomena, and an explanation of which cannot but throw much light on many of the more important and difficult problems of the atmosphere. The data chiefly required are—barometric data from which the amplitude of the four daily oscillations can be represented in their distribution and times of occurrence for each of the months; temperature data, comparable *inter se*, from which the diurnal march of temperature for each month can be ascertained; hygrometric data for hourly values; rain data also for the hours; wind observations conducted on a satisfactory and uniform plan; together with magnetic and electrical observations. It is singularly unfortunate that the disposition of meteorologists of recent years has been to recommend as hours of observations for places which observe only twice or thrice daily, hours which do not correspond with the times when the great barometric and thermometric daily phases occur; hence these phases cannot be noted except at the great observatories, which are too few and far apart to give sufficient data for the proper discussion of many of those questions.

Since the two maxima of daily pressure occur when the temperature is about the mean of the day, and the two minima when it is at its highest and lowest respectively, there is thus suggested a connection between the daily barometric oscillations and the daily march of temperature; and similarly a connection with the daily march of the amount of vapour and humidity of the air. The view entertained by many of the causes of the daily oscillations may be thus stated:—The *forenoon maximum* is conceived to be due to the rapidly increasing temperature, and the rapid evaporation owing to the great dryness of the air at this time of the day, and to the increased elasticity of the lowermost stratum of air which results therefrom, until a steady ascending current has set in. As the day advances, the vapour becomes more equally diffused upwards through the air, an ascending current, more or less strong and steady, is set in motion, a diminution of elasticity follows, and the pressure falls to the *afternoon minimum*. From this point the temperature declines, a system of descending currents set in, and the air of the lowermost stratum

approaches more nearly the point of saturation, and from the increased elasticity, the pressure rises to the *evening maximum*. As the deposition of dew proceeds, and the fall of temperature and consequent downward movement of the air are arrested, the elasticity is again diminished, and pressure falls to the *morning minimum*. Since the view propounded some years ago, that if the elastic force of vapour be subtracted from the whole pressure, what remains will show only one daily maximum and minimum, has not been confirmed by observation, it follows that the above explanation is quite insufficient to account for the phenomena; indeed, the view can be regarded in no other light than simply as a tentative hypothesis.

Singularly enough, Lamont and Broun, a few years ago, were led, independently of each other, to form an opinion that the daily barometric oscillations were due to the magneto-electric influence of the sun. It admits of no doubt, looking at the facts of the case so far as they have been disclosed, that the daily barometric oscillations originate with the sun, and that more than the sun's influence as exerted on the diurnal march of the temperature and humidity of the atmosphere is concerned in bringing them about. But from the facts adduced, it is equally certain that, be the originating cause what it may, its effects are enormously modified by the distribution of land and water over the globe, by the wind, and by the absolute and relative humidity of the atmosphere. The smallness of the amount of the summer oscillation from the forenoon maximum to the afternoon minimum over the North Atlantic as far south as lat. 30°, and its diminished amount, as far south at least as the equator, will no doubt play an important part in the unravelling of this difficulty.

One of the most important steps that could be taken would be an extensive series of observations from such countries as India, which offers such splendid contrasts of climate at all seasons, has a surface covered at one place with the richest vegetation, and at others with vast stretches of sandy deserts, and presents extensive plateaus and sharp ascending peaks—all which conditions are indispensable in collecting the data required for the solution of this vital problem of atmospheric physics.

The ancients thought that air was one of the four elements from which all things originated, and this doctrine continued to prevail till 1774, when Priestley discovered oxygen gas, and showed it to be a constituent part of air. Nitrogen, the other constituent of air, first called *azote*, was discovered soon after, and the marked differences between these two gases could not fail to strike the most careless observer. It is remarkable that Scheele independently discovered both oxygen and nitrogen, and was the first to enunciate the opinion that air consists essentially of a mixture of these two gases. From experiments made by him to ascertain their relative volumes he concluded that the proportions are 27 volumes of oxygen and 73 volumes of nitrogen. It was left to Cavendish to show from 500 analyses that the relative proportions were practically constant, and that the proportion is 20.833 per cent. of oxygen. The results obtained by Cavendish, though not attended to for many years after they were published, have been shown by recent and more refined analyses to be wonderfully exact. The most recent analyses of specimens of air collected under circumstances which ensure that it is of average purity, give as a mean result the following:—

	Volume.
Oxygen.....	20.96 per cent.
Nitrogen.....	79.00    "
Carbonic acid.....	0.04       "
	100.00

The circumstances under which these proportions vary,

and the other gases and substances which are found in the air, will be afterwards adverted to.

Besides these three constituents of air, there is a fourth, viz., the vapour of water, from which no air, even at the lowest temperatures yet observed, is wholly free, so that absolutely dry air does not exist in the free atmosphere. The dry air of the atmosphere—oxygen (inclusive of ozone), nitrogen, and carbonic acid—is always a gas, and its quantity is constant from year to year; but the vapour of water does not always remain in the gaseous state, and the quantity present in the atmosphere is, by the processes of evaporation and condensation, varying every instant. Water evaporates at all temperatures, even the lowest, and rises into the air in the form of an invisible elastic gas called aqueous vapour. The elasticity of vapour varies with the temperature. At 0° Fahr. it is capable of sustaining a pressure equal to 0.044 inch of the mercurial barometer, as calculated from Regnault's experiments; at 32° (freezing), 0.131 inch; at 60°, 0.518 inch; at 80°, 1.023 inch; and at 100°, 1.918 inch, being nearly  $\frac{1}{4}$  the average pressure of the atmosphere.

In investigating the hygrometry of the atmosphere, the chief points to be ascertained are—(1), the temperature of the air; (2), the dew-point; (3), the elastic force of vapour, or the amount of barometric pressure due to the vapour present; (4), the quantity of vapour in, say, a cubic foot of air; (5), the additional vapour required to saturate a cubic foot of air; (6), the relative humidity; and (7), the weight of a cubic foot of air at the pressure at the time of observation. The vapour of the atmosphere is observed by means of the hygrometer (see *HYGROMETER*), of which it is only necessary here to refer to *Regnault's* as the most exact, and *August's* as the most convenient, and, consequently, the one in most general use. August's hygrometer consists of a dry and a wet bulb, with which are observed the temperature of the air and the temperature of evaporation. Of these two observed data, the formula of reduction, as deduced from Apjohn's investigations, is as follows:—Let  $F$  be the elastic force of saturated vapour at the dew-point,  $f$  the elastic force at the temperature of evaporation,  $d$  the difference between the dry and wet bulb, and  $b$  the barometric pressure, then

$$F = f - \frac{d}{98} \times \frac{b}{30}$$

when the reading of the wet bulb is above 32°; and

$$F = f - \frac{d}{96} \times \frac{b}{30}$$

when below it. From Regnault's values of the elastic force of vapour,  $f$  is found, and  $d$  and  $b$  being observed,  $F$  is calculated. From  $F$  the dew-point is found. In calculating relative humidity, saturation is usually assumed to be 100, perfectly dry air 0. The humidity is found by dividing the elastic force at the dew-point by the elastic force at the temperature of the air, and multiplying the quotient by 100.

The elastic force may be regarded as representing approximately the absolute quantity of vapour suspended in the air. It may be termed the absolute humidity of the atmosphere. Since the chief disturbing influences at work in the atmosphere are the forces called into play by its aqueous vapour, a knowledge of the geographical distribution of this constituent through the months of the year is of the utmost possible importance. Hence every effort ought to be made to place the observation of the hygrometry of the air, and the reduction of the observed data, on a sounder basis than has yet been done. As regards geographical distribution, the elastic force is greatest within the tropics, and diminishes towards the poles: it is greater over

the ocean, and decreases on advancing inland; greater in summer than in winter; and greater at midday than in the morning. It diminishes with the height generally; but in particular cases, different strata are superimposed on each other, differing widely as regards dryness and humidity, and the transitions from the one to the other are often sharp and sudden.

The relative humidity of the air may be regarded as the degree of approach to saturation. It is greatest near the surface of the earth during night, when the temperature, being at or near the daily minimum, approaches the dew-point; it is also great in the morning, when the sun's rays have evaporated the dew, and the vapour is as yet only diffused a little way upwards; and it is least during the greatest heat of the day.

Between the humidity, both absolute and relative, of the air and the temperature there is a vital and all-important connection. Observation shows that when the quantity of vapour in the air is great, and also when the relative humidity is high, temperature falls little during the night, even though the sky be perfectly clear; but when the quantity of vapour is small, or the relative humidity is low, temperature rapidly falls. On the other hand, during the day the temperature rises slowly, when the quantity of vapour is great, or relative humidity high, even though the sky be clear, but when the quantity of vapour is small, and humidity low, temperature rapidly rises. These facts are explained by the circumstance that perfectly dry air is diathermanous, that is, it allows radiant heat to pass through it without being sensibly warmed thereby. Add vapour to this air, and its diathermancy is diminished. The diathermancy is also reduced if the temperature approach nearer to the dew-point; in other words, if the relative humidity be increased. Hence, with an increase of vapour or with increased humidity, the effects of both solar and terrestrial radiation are much less felt on the surface of the earth—the vapour screen performing, in truth, one of the most important conservative functions of the atmosphere.

Since ascending currents fall in temperature as they ascend, through diminished pressure and consequent dilatation, they increase their relative humidity; and since descending currents increase in temperature, and consequently reduce their relative humidity, it follows that, over a region from which ascending currents rise, solar and terrestrial radiation is very considerably obstructed, but over a region upon which currents descend, radiation is much less obstructed. Most of our exceptionally hot summer and cold winter weather is to be explained in this way, on which occasions there is generally observed a high barometric pressure overspreading a comparatively limited region, on which a slow downward movement of the air proceeds.

Of the solar heat which reaches the surface of the globe, that part which falls on the land may be regarded as wholly absorbed by the thin superficial layer exposed to the heating rays; and since there is no mobility in the particles of the land, the heat can be communicated downwards only by conduction. On the other hand, the solar heat which falls on water is not, as in the case of land, arrested at the surface, but penetrates to a considerable depth, the heating effect being in the case of clear water appreciably felt at a depth of from 500 to 600 feet. Since the heat daily received by the ocean from the sun is diffused downwards through a very considerable depth, the surface of the ocean on which the atmosphere rests is much less heated during the day than is the surface of the land. Similarly it is also less cooled during the night by terrestrial radiation.

This points to a chief acting force on which the great movements of the atmosphere depend, viz., simultaneous

local irregularities in the distribution of temperature in the atmosphere. The local expansion of the atmosphere by heat during the day is greatest over land, where the air is clear, dry, and comparatively calm, and least over the ocean, where the sky is clouded, and the air loaded with moisture. On the other hand, the local contraction by cold during night is greatest over land, where the air is clear, dry, and calm, or nearly so, and least over the ocean, where the air is clouded, and loaded with moisture. As familiar illustrations of atmospheric movements resulting from local expansions by heat and contractions by cold, we may refer to the land and sea breezes, and what depend upon exactly the same principle, the dry and rainy monsoons in different parts of the globe. But the illustration of the principle on the broadest scale is the system of atmospheric circulation known as the equatorial and polar currents of the atmosphere, which originate in the unequal heating by the sun of the equatorial, temperate, and polar regions.

The other principal motive force in atmospheric circulation depends on the aqueous vapour. The many ways in which this element acts as a motive force will be seen when it is considered that a large quantity of sensible heat disappears in the process of evaporation, and reappears in the process of condensation of the vapour into rain or cloud; that saturated air is specifically lighter than dry air; and that the absolute and relative amount of the vapour powerfully influences both solar and terrestrial radiation. The question to be carefully considered here is, how in these ways the vapour produces local irregularities in the distribution of atmospheric pressure, thus giving rise to serial movements which set in to restore the equilibrium that has thus been disturbed.

It is from these local irregularities—using the word local in a very wide sense—in the distribution of atmospheric pressure, whether the irregularities originate in the temperature or aqueous vapour, that all winds, from the lightest breeze to the most destructive hurricane, take their rise; for, as already stated, wind is merely the flowing away of the air from where there is a surplus of it to where there is a deficiency.

In examining weather charts embracing a considerable portion of the earth's surface, such, for instance, as those published in the *Journal of the Scottish Meteorological Society*, vol. ii. p. 198, which include a large part of the northern hemisphere, there are seen two different systems of pressure changing their forms and positions on the globe from day to day—one set being systems of low pressure marked off by concentric isobars enclosing pressures successively lower as the central space is approached, and the other set being systems of high pressure marked off by roughly concentric isobars bounding pressures successively higher towards their centres. These two systems are essentially distinct from each other, and without some knowledge of them the circulation of the atmosphere cannot be understood.

1. *Areas of Low Pressure, or Cyclones.*—The annexed woodcut, fig. 1, is a good representation of a cyclone which passed over north-western Europe on the morning of 2d November 1863. The pressure in the central space is 28.9 inches, from which it rises successively, as shown by the isobars, to 29.1, 29.3, 29.5, 29.7, and 29.9 inches. The arrows show the direction and force of the wind, the force rising with the number of feathers on the arrows. The two chief points to be noted are the following:—(1.) The *direction* of the arrows shows a vorticose motion of the air inwards upon the space of lowest pressure, the motion being contrary to that of the hands of a watch. It will be observed that the winds blow in conformity with what is known as Buys-Ballot's "Law of the Winds," already

referred to, but which may be otherwise thus put:—Stand with your back to the wind, and the lowest barometer, or centre of depression, will be to your left in the northern hemisphere (in the southern hemisphere to the right); this rule holds universally.

(2.) The force of the wind is proportional to the barometric gradient, or the quotient of the distance between two places stated in miles by the difference of pressure stated in inches of mercury as observed at the two places. Hence, in the Channel, where the isobars are close together, winds are high, but in the north of Scotland, where the isobars are far apart, winds are light. This rule also holds universally, though the exact relation requires still to be worked out by observation. As regards the important climatic elements of temperature and moisture, the air in the S.S.E. half of the cyclone is mild and humid, and much rain falls; but in the other half it is cold and dry, and little rain falls. A succession of low pressures passing eastward, in a course lying to northwards of Great Britain, is the characteristic of an open winter in Great Britain; on the other hand, if the cyclones follow a course lying to the southward, the winters are severe. This is a chief point of climatic importance connected with the propagation eastward of these cyclonic areas.

#### 2. Areas of High Pressures, or Anticyclones—The accom-

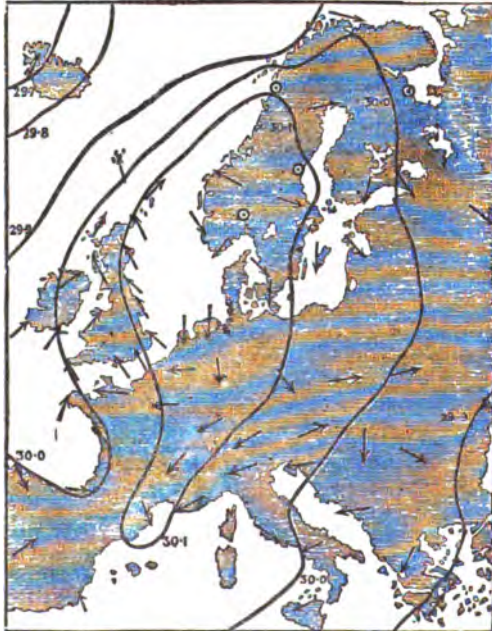

FIG. 2.—Weather chart, showing anticyclone.

panying weather chart, fig. 2, for 2-4th August 1868, represents an anticyclone or region of high pressure, which

overspread the greater part of Europe at that time. Here the highest pressure is in the centre of the system, and, as usually happens, the isobars are less symmetrical than those near the centre of a cyclone. The winds, as usual in anticyclones, are light; this, however, is the essential point of difference—the winds do not flow inwards upon the centre, but outwards from the region of high pressure; and it will be observed that in many cases they cut the isobars at nearly right angles. Another important point of difference is in the air over the region covered by the anticyclone being, particularly in its central portion, very dry, and either clear or nearly free from clouds.

Climatically, the significance of the anticyclone consists in the space covered for the time by it being, on account of its dryness and clearness, more fully under the influence of both solar and terrestrial radiation; and consequently in winter it is accompanied with great cold, and in summer with great heat. As shown by Buchan, in reviewing the weather of north-western Europe for 1868, the intense heat which prevailed in Great Britain during 2-4th August of that year was due to the high barometric pressure accompanying this anticyclone, the comparative calmness of the atmosphere, the clearness of the sky, the dryness of the air, and the strong insolation which took place under these circumstances.

Thus, then, the tendency of the winds on the surface of the earth is to blow round and in upon the space where pressures are low and out of the space where pressures are high. Now, since vast volumes of air are in this way poured into the space where pressure is low, without increasing that pressure, and, on the other hand, vast volumes flow out of the space where pressure is high, without diminishing that pressure, it necessarily follows that the air poured in is not allowed to accumulate over this space, but must escape into other regions; and also that the air which flows out from the anticyclonic region must have its place supplied by fresh accessions from above. In other words, the central space of the cyclone is occupied by a vast ascending current, which after rising to a considerable height flows away as upper currents into surrounding regions; and the central space of the anticyclone is filled by a slowly descending current, which is fed from upper currents, blowing towards it from neighbouring regions. When the area of observation is made sufficiently wide, cyclones are seen to have one, or sometimes more, anticyclones in proximity to them, the better marked anticyclones having two, and sometimes more, cyclones in their vicinity. In fig. 2, a part of a cyclone in Iceland is seen, and another cyclone in the Crimea accompanied the anticyclone there figured. Hence the cyclone and the anticyclone are properly to be regarded as counterparts, belonging to one and the same great atmospheric disturbance.

From this it follows that observations of the winds cannot be conducted, and the results discussed, on the supposition that the general movement of the winds felt on the earth's surface is horizontal, it being evident that the circulation of the atmosphere is effected largely through systems of ascending and descending currents. The only satisfactory way of discussing the winds, viewed especially in their climatic relations, is that recently proposed by Köppen of St Petersburg, and applied by him with very fruitful results in investigating the weather of that place during 1872 and 1873. In attempting an explanation of these phenomena, we are met with several as yet insuperable obstacles—(1.) An imperfect knowledge of the mode

<sup>1</sup> *Atlas Météorologique de l'Observatoire Impérial, Année 1868.* D. 39.

of formation and propagation of low-pressure systems; (2.) Imperfect knowledge of the relations of the formation of cloud and aqueous precipitation to barometric fluctuations; (3.) A want of information with reference to the merely mechanical effects of ascending, descending, and horizontal currents of air or the barometric pressure; in other words, we do not know how far the barometric pressure is an indication of the mass of air in the column vertically over it, when that column is traversed by air-currents; (4.) An almost total absence of really good wind observations; and (5.) Deficient information in nearly everything that respects aqueous vapour—its relation to radiant heat, both solar and terrestrial; its mode of diffusion vertically and horizontally in the free atmosphere, especially from an evaporating surface; the influence which its condensation into cloud and rain exerts on aerial currents,—in regard to all which more satisfactory methods of observing this vital element, and discussing the results of observation, are greatly to be desired. There are here large important fields of inquiry awaiting experimental and observational physicists.

The law of the dilatation of gases, known as the "Law of Boyle" or "Law of Mariotte," is this: The volume occupied by a gas is in inverse ratio to the pressure under which it exists, if the temperature remains the same; or the density of a gas is proportioned to its pressure. Consequently, air under a pressure equal to that of two atmospheres will occupy only half the volume it occupied under the pressure of one atmosphere; under the pressure of three atmospheres, one-third of that volume, &c. By doubling the pressure we double the elasticity. If, however, the temperature be increased, and the air occupy the same space, the pressure will be increased; but if the pressure is to remain the same, the air must occupy a larger space. From Regnault's experiments, it is concluded that the co-efficient which denotes increase of elasticity for 1° Fahr. of air whose volume is constant equals '002036; and that the co-efficient which denotes increase of volume for 1° Fahr. of air whose elasticity is constant equals '002039.

Those portions of the atmosphere in contact with the earth are pressed upon by all the air above them. The air at the top of a mountain is pressed upon by all the air above it, while all the portion below it, or lying between the top of the mountain and the surface of the sea, exerts no pressure whatever upon it. Thus the pressure of the atmosphere constantly diminishes with the height. If, then, the pressure of the atmosphere at two heights be observed, and if at the same time the mean temperature and humidity of the whole stratum of air lying between the two levels were known, the difference in height between the two places could be calculated. For the development of this principle, see BAROMETRIC MEASUREMENTS OF HEIGHTS.

The air thus diminishing in density as we ascend, if it consists of ultimate atoms, as is no doubt the case, it follows that the limit of the atmosphere will be reached at the height where the force of gravity downwards upon a single particle is equal to the resisting force arising from the repulsive force of the particles. It was long supposed, from the results of observations on the refraction of light, that the height of the atmosphere did not exceed 45 miles; but from the observations of luminous meteors, whose true character as comical bodies was established a few years ago, it is inferred that the height of the atmosphere is at least 120 miles, and that, in an extremely attenuated form, it may even reach 200 miles.

Though there are considerable differences in the specific gravities of the four constituent gases of the atmosphere, viz, oxygen, nitrogen, carbonic acid gas, and aqueous vapour, there is yet no tendency to separation among them,

owing to the law of diffusion obtaining among elastic fluids mixed together. While the proportion of these gases is in a general sense constant, there are, however, constant differences in the amounts of oxygen and nitrogen in the air of unwholesome places, as first shown by Regnault. The following figures, showing the volume per cent. of oxygen, rest on the authority of Dr Angus Smith, who has given much attention to this subject:—Sea-shore of Scotland and Atlantic (lat. 43° 5' N., long. 17° 12' W.), 20.99; tops of Scottish hills, 20.98; in sitting-room feeling close but not excessively so, 20.89; backs of houses and closets, 20.70; under shafts in metalliferous mines, 20.424; when candles go out, 18.50; when it is very difficult to remain in the air many minutes, 17.20. The variations in the amounts of carbonic acid in different situations are great; thus—in the London parks it is .0301; on the Thames, .0343; where fields begin, .0369; in London streets in summer, .0380; during fogs in Manchester, .0679; in workahops it rises to .3000, and in the worst parts of theatres to .3200; and the largest amount, found in Cornwall mines, is 2.5000.

Great differences have been observed by Dr A. Smith between country rain and town rain: country rain is neutral; town rain, on the other hand, is acid, and corrodes metals and even stones and bricks, destroying mortar rapidly, and readily spoiling many colours. Much information has been obtained regarding impurities in the air of towns and other places by examining the rain collected in different places. The air freed from impurities is that collected at the sea-coast and at considerable heights. Again, ammonia is found to diminish, while nitric acid increases, in ascending to, at least, habitable heights. As regards organic matter in the air, it corresponds to a considerable extent with the density of the population. As might have been supposed from the higher temperature, more nitric acid is contained in rain collected on the Continent than in the British Islands. This inquiry, which is only yet in its infancy, will doubtless continue to be vigorously prosecuted, particularly since we may hope thereby to arrive at the means of authoritatively defining the safe limits of the density of population, and the extent to which manufactures may be carried on within a given area. The influence of atmospheric impurities on the public health has received a good deal of attention.

The relation of weather to mortality is a very important inquiry, and though a good deal has been known regarding the question for some time, yet it has only recently been systematically inquired into by Dr Arthur Mitchell and Mr Buchan, the results of the investigation which deals with the mortality of London being published in the *Journal of the Scottish Meteorological Society* (New Series, Nos. 43 to 46). Considering the weather of the year as made up of several distinct climates differing from each other according to temperature and moisture and their relations to each other, it may be divided into six distinct climates, characterised respectively by cold, cold with dryness, dryness with heat, heat, heat with moisture, and cold with moisture. Each of these six periods has a peculiar influence in increasing or diminishing the mortality, and each has its own group of diseases which rise to the maximum, or fall to the minimum mortality, or are subject to a rapid increase or a rapid decrease. The mortality from all causes and at all ages shows a large excess above the average from the middle of November to the middle of April, from which it falls to the minimum in the end of May; it then slowly rises, and on the third week of July suddenly shoots up almost as high as the winter maximum of the year, at which it remains till the second week of August, falling thence as rapidly as it rose to a secondary minimum in October. Regarding the summer excess, which is so abrupt in its rise and fall, it is almost altogether

due to the enormous increase of the mortality among mere infants under one year of age; and this increase is due not only to deaths at one age, but to deaths from one class of diseases, viz, bowel complaints. If the deaths from bowel complaints be deducted from the deaths from all causes, there remains an excess of deaths in the cold months, and a deficiency in the warm months. In other words, the curve of mortality is regulated by the large number of deaths from diseases of the respiratory organs. The curve of mortality for London, if mere infants be excepted, has thus an inverse relation to the temperature, rising as the temperature falls, and falling as the temperature rises. On the other hand, in Victoria, Australia, where the summers are hotter and the winters milder, the curves of mortality and temperature are directly related to each other—mortality and temperature rising and falling

together; the reason being that in Victoria deaths from bowel complaints are much greater, and those from diseases of the respiratory organs much less than in London.

The curves show that the maximum annual mortality from the different diseases groups around certain specific conditions of temperature and moisture combined. Thus, *cold and moist weather* is accompanied with a high death-rate from rheumatism, heart diseases, diphtheria, and measles; *cold weather*, with a high death-rate from bronchitis, pneumonia, &c.; *cold and dry weather*, with a high death-rate from brain diseases, whooping-cough, convulsions; *warm and dry weather*, with a high death-rate from suicide and small-pox; *hot weather*, with a high death-rate from bowel complaints; and *warm moist weather* with a high death-rate from scarlet and typhoid fevers. (See CLIMATE.) (A. B.)

**ATMOSPHERIC RAILWAY**, a railway in which the pressure of air is used directly or indirectly to propel carriages, as a substitute for steam. It was devised at a time when the principles of propulsion were not so well understood as they are now, and when the dangers and inconveniences attendant on the use of locomotives were very much exaggerated. It had been long known that small objects could be propelled for great distances through tubes by air pressure, but a Mr Vallance, of Brighton, seems to have been the first to propose the application of this system to passenger traffic. He projected (about 1825) an atmospheric railway, consisting of a wooden tube about 6 feet 6 inches in diameter, with a carriage running inside it. A diaphragm fitting the tube, approximately air-tight, was attached to the carriage, and the air exhausted from the front of it by a stationary engine, so that the atmospheric pressure behind drove the carriage forward. Later inventors, commencing with Henry Pinkus (1835), for the most part kept the carriages altogether outside the tube, and connected them by a bar with a piston working inside it, this piston being moved by atmospheric pressure in the way just mentioned. The tube was generally provided with a slot upon its upper side, closed by a continuous valve or its equivalent, and arrangements were made by which this valve should be opened to allow the passage of the driving bar without permitting great leakage of air. About 1840, Messrs Clegg & Samuda made various experiments with an atmospheric tube constructed on this principle upon a portion of the West London Railway, near Wormwood Scrubs. The apparent success of these induced the Dublin

and Kingstown Railway to adopt Clegg & Samuda's scheme upon an extension of their line from Kingstown to Dalkey, where it was in operation in 1844. Later on, the same system was adopted on a part of the South Devon line and in several other places, and during the years 1844-1846 the English and French patent records show a very large number of more or less practicable and ingenious schemes for the tubes, valves, and driving gear of atmospheric railways. The atmospheric system was nowhere permanently successful, but in all cases was eventually superseded by locomotives, the last atmospheric line being probably that at St Germain, which was worked until 1862. Apart from difficulties in connection with the working of the valve, the maintenance of the vacuum, &c., other great practical difficulties, which had not been indicated by the experiments, soon made themselves known in the working of the lines. Above all, it was found that stationary engines, whether hauling a rope or exhausting a tube, could never work a railway with anything like the economy or the convenience of locomotives, a point which is now regarded as settled by engineers, but which was not so thoroughly understood thirty years ago. Lately, the principle of the atmospheric railway has been applied on a very large scale in London and elsewhere, under the name of "PNEUMATIC DESPATCH" (q.v.), to the transmission of small parcels in connection with postal and telegraph work, for which purpose it has proved admirably adapted. (See paper by Prof. Sternberg of Karlsruhe in Hensinger von Waldegg's *Handbuch für specielle Eisenbahntechnik*, vol. i. pt. 2, cap. xvii.)

## A T O M

**A T O M** (*ἄτομος*) is a body which cannot be cut in two. The atomic theory is a theory of the constitution of bodies, which asserts that they are made up of atoms. The opposite theory is that of the homogeneity and continuity of bodies, and asserts, at least in the case of bodies having no apparent organisation, such, for instance, as water, that as we can divide a drop of water into two parts which are each of them drops of water, so we have reason to believe that these smaller drops can be divided again, and the theory goes on to assert that there is nothing in the nature of things to hinder this process of division from being repeated over and over again, times without end. This is the doctrine of the infinite divisibility of bodies, and it is in direct contradiction with the theory of atoms.

The atomists assert that after a certain number of such divisions the parts would be no longer divisible, because each of them would be an atom. The advocates of the

continuity of matter assert that the smallest conceivable body has parts, and that whatever has parts may be divided.

In ancient times Democritus was the founder of the atomic theory, while Anaxagoras propounded that of continuity, under the name of the doctrine of homœomeria (*ὁμοιομέρεια*), or of the similarity of the parts of a body to the whole. The arguments of the atomists, and their replies to the objections of Anaxagoras, are to be found in Lucretius.

In modern times the study of nature has brought to light many properties of bodies which appear to depend on the magnitude and motions of their ultimate constituents, and the question of the existence of atoms has once more become conspicuous among scientific inquiries.

We shall begin by stating the opposing doctrines of atoms and of continuity before giving an outline of the state of



molecular science as it now exists. In the earliest times the most ancient philosophers whose speculations are known to us seem to have discussed the ideas of number and of continuous magnitude, of space and time, of matter and motion, with a native power of thought which has probably never been surpassed. Their actual knowledge, however, and their scientific experience were necessarily limited, because in their days the records of human thought were only beginning to accumulate. It is probable that the first exact notions of quantity were founded on the consideration of number. It is by the help of numbers that concrete quantities are practically measured and calculated. Now, number is discontinuous. We pass from one number to the next *per saltum*. The magnitudes, on the other hand, which we meet with in geometry, are essentially continuous. The attempt to apply numerical methods to the comparison of geometrical quantities led to the doctrine of incommensurables, and to that of the infinite divisibility of space. Meanwhile, the same considerations had not been applied to time, so that in the days of Zeno of Elea time was still regarded as made up of a finite number of "moments," while space was confessed to be divisible without limit. This was the state of opinion when the celebrated arguments against the possibility of motion, of which that of Achilles and the tortoise is a specimen, were propounded by Zeno, and such, apparently, continued to be the state of opinion till Aristotle pointed out that time is divisible without limit, in precisely the same sense that space is. And the slowness of the development of scientific ideas may be estimated from the fact that Bayle does not see any force in this statement of Aristotle, but continues to admire the paradox of Zeno. (Bayle's *Dictionary*, art. "Zeno"). Thus the direction of true scientific progress was for many ages towards the recognition of the infinite divisibility of space and time.

It was easy to attempt to apply similar arguments to matter. If matter is extended and fills space, the same mental operation by which we recognise the divisibility of space may be applied, in imagination at least, to the matter which occupies space. From this point of view the atomic doctrine might be regarded as a relic of the old numerical way of conceiving magnitude, and the opposite doctrine of the infinite divisibility of matter might appear for a time the most scientific. The atomists, on the other hand, asserted very strongly the distinction between matter and space. The atoms, they said, do not fill up the universe; there are void spaces between them. If it were not so, Lucretius tells us, there could be no motion, for the atom which gives way first must have some empty place to move into.

"Quaspropter locus est intactus, inane, vacansque  
 Quod si non esset, nulla ratione moveri  
 Res possent; namque, officium quod corporis exstat,  
 Officium atque obstat, id in omni tempore adesset  
 Omnibus: haud igitur quicquam procedere posset,  
 Principium quoniam cedendi nulla daret res."  
 —*De Rerum Natura*, l. 385.

The opposite school maintained then, as they have always done, that there is no vacuum—that every part of space is full of matter, that there is a universal plenum, and that all motion is like that of a fish in the water, which yields in front of the fish because the fish leaves room for it behind.

"Cedere squamigeris latices nitentibus aiant  
 Et liquidas aperire vias, quia post loca pisces  
 Linquant, quo possint cedentes confluere undae."  
 373.

In modern times Descartes held that, as it is of the essence of matter to be extended in length, breadth, and thickness, so it is of the essence of extension to be occu-

piated by matter, for extension cannot be an extension of nothing.

"Ac proinde si quaeratur quid fiet, si Deus auferat omne corpus quod in aliquo vase continetur, et nullum aliud in ablato locum venire permittat? respondendum est, vasis latera sibi invicem hoc ipso fore contigua. Cum enim inter duo corpora nihil interjacet, necesse est ut se mutuo tangant, ac manifeste repugnat ut distent, sive ut inter ipsa sit distantia, et tamen ut ista distantia sit nihil; quia omnis distantia est modus extensionis, et ideo sine substantia extensa esse non potest."—*Principia*, ii. 18.

This identification of extension with substance runs through the whole of Descartes's works, and it forms one of the ultimate foundations of the system of Spinoza. Descartes, consistently with this doctrine, denied the existence of atoms as parts of matter, which by their own nature are indivisible. He seems to admit, however, that the Deity might make certain particles of matter indivisible in this sense, that no creature should be able to divide them. These particles, however, would be still divisible by their own nature, because the Deity cannot diminish his own power, and therefore must retain his power of dividing them. Leibnitz, on the other hand, regarded his monad as the ultimate element of everything.

There are thus two modes of thinking about the constitution of bodies, which have had their adherents both in ancient and in modern times. They correspond to the two methods of regarding quantity—the arithmetical and the geometrical. To the atomist the true method of estimating the quantity of matter in a body is to count the atoms in it. The void spaces between the atoms count for nothing. To those who identify matter with extension, the volume of space occupied by a body is the only measure of the quantity of matter in it.

Of the different forms of the atomic theory, that of Boscovich may be taken as an example of the purest monadism. According to Boscovich matter is made up of atoms. Each atom is an indivisible point, having position in space, capable of motion in a continuous path, and possessing a certain mass, whereby a certain amount of force is required to produce a given change of motion: Besides this the atom is endowed with potential force, that is to say, that any two atoms attract or repel each other with a force depending on their distance apart. The law of this force, for all distances greater than say the thousandth of an inch, is an attraction varying as the inverse square of the distance. For smaller distances the force is an attraction for one distance and a repulsion for another, according to some law not yet discovered. Boscovich himself, in order to obviate the possibility of two atoms ever being in the same place, asserts that the ultimate force is a repulsion which increases without limit as the distance diminishes without limit, so that two atoms can never coincide. But this seems an unwarrantable concession to the vulgar opinion that two bodies cannot co-exist in the same place. This opinion is deduced from our experience of the behaviour of bodies of sensible size, but we have no experimental evidence that two atoms may not sometimes coincide. For instance, if oxygen and hydrogen combine to form water, we have no experimental evidence that the molecule of oxygen is not in the very same place with the two molecules of hydrogen. Many persons cannot get rid of the opinion that all matter is extended in length, breadth, and depth. This is a prejudice of the same kind with the last, arising from our experience of bodies consisting of immense multitudes of atoms. The system of atoms, according to Boscovich, occupies a certain region of space in virtue of the forces acting between the component atoms of the system and any other atoms when brought near them. No other system of atoms can occupy the same region of space at the same time, because, before it could do so, the mutual

action of the atoms would have caused a repulsion between the two systems insuperable by any force which we can command. Thus, a number of soldiers with firearms may occupy an extensive region to the exclusion of the enemy's armies, though the space filled by their bodies is but small. In this way Boscovich explained the apparent extension of bodies consisting of atoms, each of which is devoid of extension. According to Boscovich's theory, all action between bodies is action at a distance. There is no such thing in nature as actual contact between two bodies. When two bodies are said in ordinary language to be in contact, all that is meant is that they are so near together that the repulsion between the nearest pairs of atoms belonging to the two bodies is very great.

Thus, in Boscovich's theory, the atom has continuity of existence in time and space. At any instant of time it is at some point of space, and it is never in more than one place at a time. It passes from one place to another along a continuous path. It has a definite mass which cannot be increased or diminished. Atoms are endowed with the power of acting on one another by attraction or repulsion, the amount of the force depending on the distance between them. On the other hand, the atom itself has no parts or dimensions. In its geometrical aspect it is a mere geometrical point. It has no extension in space. It has not the so-called property of impenetrability, for two atoms may exist in the same place. This we may regard as one extreme of the various opinions about the constitution of bodies.

The opposite extreme, that of Anaxagoras—the theory that bodies apparently homogeneous and continuous are so in reality—is, in its extreme form, a theory incapable of development. To explain the properties of any substance by this theory is impossible. We can only admit the observed properties of such substance as ultimate facts. There is a certain stage, however, of scientific progress in which a method corresponding to this theory is of service. In hydrostatics, for instance, we define a fluid by means of one of its known properties, and from this definition we make the system of deductions which constitutes the science of hydrostatics. In this way the science of hydrostatics may be built upon an experimental basis, without any consideration of the constitution of a fluid as to whether it is molecular or continuous. In like manner, after the French mathematicians had attempted, with more or less ingenuity, to construct a theory of elastic solids from the hypothesis that they consist of atoms in equilibrium under the action of their mutual forces, Stokes and others showed that all the results of this hypothesis, so far at least as they agreed with facts, might be deduced from the postulate that elastic bodies exist, and from the hypothesis that the smallest portions into which we can divide them are sensibly homogeneous. In this way the principle of continuity, which is the basis of the method of Fluxions and the whole of modern mathematics, may be applied to the analysis of problems connected with material bodies by assuming them, for the purpose of this analysis, to be homogeneous. All that is required to make the results applicable to the real case is that the smallest portions of the substance of which we take any notice shall be sensibly of the same kind. Thus, if a railway contractor has to make a tunnel through a hill of gravel, and if one cubic yard of the gravel is so like another cubic yard that for the purposes of the contract they may be taken as equivalent, then, in estimating the work required to remove the gravel from the tunnel, he may, without fear of error, make his calculations as if the gravel were a continuous substance. But if a worm has to make his way through the gravel, it makes the greatest possible difference to him whether he tries to push right against a piece of gravel, or directs his course through

one of the intervals between the pieces; to him, therefore, the gravel is by no means a homogeneous and continuous substance.

In the same way, a theory that some particular substance, say water, is homogeneous and continuous may be a good working theory up to a certain point, but may fail when we come to deal with quantities so minute or so attenuated that their heterogeneity of structure comes into prominence. Whether this heterogeneity of structure is or is not consistent with homogeneity and continuity of substance is another question.

The extreme form of the doctrine of continuity is that stated by Descartes, who maintains that the whole universe is equally full of matter, and that this matter is all of one kind, having no essential property besides that of extension. All the properties which we perceive in matter he reduces to its parts being movable among one another, and so capable of all the varieties which we can perceive to follow from the motion of its parts (*Principia*, ii. 23). Descartes's own attempts to deduce the different qualities and actions of bodies in this way are not of much value. More than a century was required to invent methods of investigating the conditions of the motion of systems of bodies such as Descartes imagined. But the hydrodynamical discovery of Helmholtz that a vortex in a perfect liquid possesses certain permanent characteristics, has been applied by Sir W. Thomson to form a theory of vortex atoms in a homogeneous, incompressible, and frictionless liquid, to which we shall return at the proper time.

#### OUTLINE OF MODERN MOLECULAR SCIENCE, AND IN PARTICULAR OF THE MOLECULAR THEORY OF GASES.

We begin by assuming that bodies are made up of parts, each of which is capable of motion, and that these parts act on each other in a manner consistent with the principle of the conservation of energy. In making these assumptions, we are justified by the facts that bodies may be divided into smaller parts, and that all bodies with which we are acquainted are conservative systems, which would not be the case unless their parts were also conservative systems.

We may also assume that these small parts are in motion. This is the most general assumption we can make, for it includes, as a particular case, the theory that the small parts are at rest. The phenomena of the diffusion of gases and liquids through each other show that there may be a motion of the small parts of a body which is not perceptible to us.

We make no assumption with respect to the nature of the small parts—whether they are all of one magnitude. We do not even assume them to have extension and figure. Each of them must be measured by its mass, and any two of them must, like visible bodies, have the power of acting on one another when they come near enough to do so. The properties of the body, or medium, are determined by the configuration and motion of its small parts.

The first step in the investigation is to determine the amount of motion which exists among the small parts, independent of the visible motion of the medium as a whole. For this purpose it is convenient to make use of a general theorem in dynamics due to Clausius.

When the motion of a material system is such that the time-average of the quantity  $\sum(mv^2)$  remains constant, the state of the system is said to be that of stationary motion. When the motion of a material system is such that the sum of the moments of inertia of the system, about three axes at right angles through its centre of mass, never varies by more than small quantities from a constant value, the system is said to be in a state of stationary motion.

The kinetic energy of a particle is half the product of its mass into the square of its velocity, and the kinetic energy of a system is the sum of the kinetic energy of all its parts.

When an attraction or repulsion exists between two points, half the product of this stress into the distance between the two points is called the *virial* of the stress, and is reckoned positive when the stress is an attraction, and negative when it is a repulsion. The virial of a system is the sum of the virials of the stresses which exist in it. If the system is subjected to the external stress of the pressure of the sides of a vessel in which it is contained, this stress will introduce an amount of virial  $\frac{2}{3}pV$ , where  $p$  is the pressure on unit of area and  $V$  is the volume of the vessel.

The theorem of Clausius may now be stated as follows :— In a material system in a state of stationary motion the time-average of the kinetic energy is equal to the time-average of the virial. In the case of a fluid enclosed in a vessel

$$\frac{1}{2}\Sigma(mv^2) = \frac{2}{3}pV + \frac{1}{2}\Sigma\Sigma(Rr),$$

where the first term denotes the kinetic energy, and is half the sum of the product of each mass into the mean square of its velocity. In the second term,  $p$  is the pressure on unit of surface of the vessel, whose volume is  $V$ , and the third term expresses the virial due to the internal actions between the parts of the system. A double symbol of summation is used, because every pair of parts between which any action exists must be taken into account. We have next to show that in gases the principal part of the pressure arises from the motion of the small parts of the medium, and not from a repulsion between them.

In the first place, if the pressure of a gas arises from the repulsion of its parts, the law of repulsion must be inversely as the distance. For, consider a cube filled with the gas at pressure  $p$ , and let the cube expand till each side is  $n$  times its former length. The pressure on unit of surface according to Boyle's law is now  $\frac{p}{n^2}$ , and since the area of a face of the cube is  $n^2$  times what it was, the whole pressure on the face of the cube is  $\frac{1}{n}$  of its original value.

But since everything has been expanded symmetrically, the distance between corresponding parts of the air is now  $n$  times what it was, and the force is  $n$  times less than it was. Hence the force must vary inversely as the distance.

But Newton has shown (*Principia*, bk. i prop. 93) that this law is inadmissible, as it makes the effect of the distant parts of the medium on a particle greater than that of the neighbouring parts. Indeed, we should arrive at the conclusion that the pressure depends not only on the density of the air but on the form and dimensions of the vessel which contains it, which we know not to be the case.

If, on the other hand, we suppose the pressure to arise entirely from the motion of the molecules of the gas, the interpretation of Boyle's law becomes very simple. For, in this case

$$pV = \frac{1}{3}\Sigma(mv^2).$$

The first term is the product of the pressure and the volume, which according to Boyle's law is constant for the same quantity of gas at the same temperature. The second term is two-thirds of the kinetic energy of the system, and we have every reason to believe that in gases when the temperature is constant the kinetic energy of unit of mass is also constant. If we admit that the kinetic energy of unit of mass is in a given gas proportional to the absolute temperature, this equation is the expression of the law of Charles as well as of that of Boyle, and may be written—

$$pV = R\theta,$$

where  $\theta$  is the temperature reckoned from absolute zero, and  $R$  is a constant. The fact that this equation expresses with considerable accuracy the relation between the volume, pressure, and temperature of a gas when in an extremely rarified state, and that as the gas is more and more compressed the deviation from this equation becomes more apparent, shows that the pressure of a gas is due almost entirely to the motion of its molecules when the gas is rare, and that it is only when the density of the gas is considerably increased that the effect of direct action between the molecules becomes apparent.

The effect of the direct action of the molecules on each other depends on the number of pairs of molecules which at a given instant are near enough to act on one another. The number of such pairs is proportional to the square of the number of molecules in unit of volume, that is, to the square of the density of the gas. Hence, as long as the medium is so rare that the encounter between two molecules is not affected by the presence of others, the deviation from Boyle's law will be proportional to the square of the density. If the action between the molecules is on the whole repulsive, the pressure will be greater than that given by Boyle's law. If it is, on the whole, attractive, the pressure will be less than that given by Boyle's law. It appears, by the experiments of Regnault and others, that the pressure does deviate from Boyle's law when the density of the gas is increased. In the case of carbonic acid and other gases which are easily liquefied, this deviation is very great. In all cases, however, except that of hydrogen, the pressure is less than that given by Boyle's law, showing that the virial is on the whole due to attractive forces between the molecules.

Another kind of evidence as to the nature of the action between the molecules is furnished by an experiment made by Dr Joule. Of two vessels, one was exhausted and the other filled with a gas at a pressure of 20 atmospheres; and both were placed side by side in a vessel of water, which was constantly stirred. The temperature of the whole was observed. Then a communication was opened between the vessels, the compressed gas expanded to twice its volume, and the work of expansion, which at first produced a strong current in the gas, was soon converted into heat by the internal friction of the gas. When all was again at rest, and the temperature uniform, the temperature was again observed. In Dr Joule's original experiments the observed temperature was the same as before. In a series of experiments, conducted by Dr Joule and Sir W. Thomson on a different plan, by which the thermal effect of free expansion can be more accurately measured, a slight cooling effect was observed in all the gases examined except hydrogen. Since the temperature depends on the velocity of agitation of the molecules, it appears that when a gas expands without doing external work the velocity of agitation is not much affected, but that in most cases it is slightly diminished. Now, if the molecules during their mutual separation act on each other, their velocity will increase or diminish according as the force is repulsive or attractive. It appears, therefore, from the experiments on the free expansion of gases, that the force between the molecules is small but, on the whole, attractive.

Having thus justified the hypothesis that a gas consists of molecules in motion, which act on each other only when they come very close together during an encounter, but which, during the intervals between their encounters which constitute the greater part of their existence, are describing free paths, and are not acted on by any molecular force, we proceed to investigate the motion of such a system.

The mathematical investigation of the properties of such

a system of molecules in motion is the foundation of molecular science. Clausius was the first to express the relation between the density of the gas, the length of the free paths of its molecules, and the distance at which they encounter each other. He assumed, however, at least in his earlier investigations, that the velocities of all the molecules are equal. The mode in which the velocities are distributed was first investigated by the present writer, who showed that in the moving system the velocities of the molecules range from zero to infinity, but that the number of molecules whose velocities lie within given limits can be expressed by a formula identical with that which expresses in the theory of errors the number of errors of observation lying within corresponding limits. The proof of this theorem has been carefully investigated by Boltzmann,<sup>1</sup> who has strengthened it where it appeared weak, and to whom the method of taking into account the action of external forces is entirely due.

The mean kinetic energy of a molecule, however, has a definite value, which is easily expressed in terms of the quantities which enter into the expression for the distribution of velocities. The most important result of this investigation is that when several kinds of molecules are in motion and acting on one another, the mean kinetic energy of a molecule is the same whatever be its mass, the molecules of greater mass having smaller mean velocities. Now, when gases are mixed their temperatures become equal. Hence we conclude that the physical condition which determines that the temperature of two gases shall be the same is that the mean kinetic energies of agitation of the individual molecules of the two gases are equal. This result is of great importance in the theory of heat, though we are not yet able to establish any similar result for bodies in the liquid or solid state.

In the next place, we know that in the case in which the whole pressure of the medium is due to the motion of its molecules, the pressure on unit of area is numerically equal to two-thirds of the kinetic energy in unit of volume. Hence, if equal volumes of two gases are at equal pressures the kinetic energy is the same in each. If they are also at equal temperatures the mean kinetic energy of each molecule is the same in each. If, therefore, equal volumes of two gases are at equal temperatures and pressures, the number of molecules in each is the same, and therefore, the masses of the two kinds of molecules are in the same ratio as the densities of the gases to which they belong.

This statement has been believed by chemists since the time of Gay-Lussac, who first established that the weights of the chemical equivalents of different substances are proportional to the densities of these substances when in the form of gas. The definition of the word molecule, however, as employed in the statement of Gay-Lussac's law is by no means identical with the definition of the same word as in the kinetic theory of gases. The chemists ascertain by experiment the ratios of the masses of the different substances in a compound. From these they deduce the chemical equivalents of the different substances, that of a particular substance, say hydrogen, being taken as unity. The only evidence made use of is that furnished by chemical combinations. It is also assumed, in order to account for the facts of combination, that the reason why substances combine in definite ratios is that the molecules of the substances are in the ratio of their chemical equivalents, and that what we call combination is an action which takes place by a union of a molecule of one substance to a molecule of the other.

This kind of reasoning, when presented in a proper form and sustained by proper evidence, has a high degree of

cogency. But it is purely chemical reasoning; it is not dynamical reasoning. It is founded on chemical experience, not on the laws of motion.

Our definition of a molecule is purely dynamical. A molecule is that minute portion of a substance which moves about as a whole, so that its parts, if it has any, do not part company during the motion of agitation of the gas. The result of the kinetic theory, therefore, is to give us information about the relative masses of molecules considered as moving bodies. The consistency of this information with the deductions of chemists from the phenomena of combination, greatly strengthens the evidence in favour of the actual existence and motion of gaseous molecules.

Another confirmation of the theory of molecules is derived from the experiments of Dulong and Petit on the specific heat of gases, from which they deduced the law which bears their name, and which asserts that the specific heats of equal weights of gases are inversely as their combining weights, or, in other words, that the capacities for heat of the chemical equivalents of different gases are equal. We have seen that the temperature is determined by the kinetic energy of agitation of each molecule. The molecule has also a certain amount of energy of internal motion, whether of rotation or of vibration, but the hypothesis of Clausius, that the mean value of the internal energy always bears a proportion fixed for each gas to the energy of agitation, seems highly probable and consistent with experiment. The whole kinetic energy is therefore equal to the energy of agitation multiplied by a certain factor. Thus the energy communicated to a gas by heating it is divided in a certain proportion between the energy of agitation and that of the internal motion of each molecule. For a given rise of temperature the energy of agitation, say of a million molecules, is increased by the same amount whatever be the gas. The heat spent in raising the temperature is measured by the increase of the whole kinetic energy. The thermal capacities, therefore, of equal numbers of molecules of different gases are in the ratio of the factors by which the energy of agitation must be multiplied to obtain the whole energy. As this factor appears to be nearly the same for all gases of the same degree of atomicity, Dulong and Petit's law is true for such gases.

Another result of this investigation is of considerable importance in relation to certain theories,<sup>2</sup> which assume the existence of æthers or rare media consisting of molecules very much smaller than those of ordinary gases. According to our result, such a medium would be neither more nor less than a gas. Supposing its molecules so small that they can penetrate between the molecules of solid substances such as glass, a so-called vacuum would be full of this rare gas at the observed temperature, and at the pressure, whatever it may be, of the ætherial medium in space. The specific heat, therefore, of the medium in the so-called vacuum will be equal to that of the same volume of any other gas at the same temperature and pressure. Now, the purpose for which this molecular æther is assumed in these theories is to act on bodies by its pressure, and for this purpose the pressure is generally assumed to be very great. Hence, according to these theories, we should find the specific heat of a so-called vacuum very considerable compared with that of a quantity of air filling the same space.

We have now made a certain definite amount of progress towards a complete molecular theory of gases. We know the mean velocity of the molecules of each gas in metres per second, and we know the relative masses of the molecules of different gases. We also know that the molecules of one and the same gas are all equal in mass. For if they

<sup>1</sup> *Sitzungsberichte der K. K. Akad., Wien*, 8th Oct. 1868.

<sup>2</sup> See Gustav Hansemann, *Die Atome und ihre Bewegungen*. 1871. (H. G. Mayer.)

are not, the method of dialysis, as employed by Graham, would enable us to separate the molecules of smaller mass from those of greater, as they would stream through porous substances with greater velocity. We should thus be able to separate a gas, say hydrogen, into two portions, having different densities and other physical properties, different combining weights, and probably different chemical properties of other kinds. As no chemist has yet obtained specimens of hydrogen differing in this way from other specimens, we conclude that all the molecules of hydrogen are of sensibly the same mass, and not merely that their mean mass is a statistical constant of great stability.

But as yet we have not considered the phenomena which enable us to form an estimate of the actual mass and dimensions of a molecule. It is to Clausius that we owe the first definite conception of the free path of a molecule and of the mean distance travelled by a molecule between successive encounters. He showed that the number of encounters of a molecule in a given time is proportional to the velocity, to the number of molecules in unit of volume, and to the square of the distance between the centres of two molecules when they act on one another so as to have an encounter. From this it appears that if we call this distance of the centres the diameter of a molecule, and the volume of a sphere having this diameter the volume of a molecule, and the sum of the volumes of all the molecules the molecular volume of the gas, then the diameter of a molecule is a certain multiple of the quantity obtained by diminishing the free path in the ratio of the molecular volume of the gas to the whole volume of the gas. The numerical value of this multiple differs slightly, according to the hypothesis we assume about the law of distribution of velocities. It also depends on the definition of an encounter. When the molecules are regarded as elastic spheres we know what is meant by an encounter, but if they act on each other at a distance by attractive or repulsive forces of finite magnitude, the distance of their centres varies during an encounter, and is not a definite quantity. Nevertheless, the above statement of Clausius enables us, if we know the length of the mean path and the molecular volume of a gas, to form a tolerably near estimate of the diameter of the sphere of the intense action of a molecule, and thence of the number of molecules in unit of volume and the actual mass of each molecule. To complete the investigation we have, therefore, to determine the mean path and the molecular volume. The first numerical estimate of the mean path of a gaseous molecule was made by the present writer from data derived from the internal friction of air. There are three phenomena which depend on the length of the free path of the molecules of a gas. It is evident that the greater the free path the more rapidly will the molecules travel from one part of the medium to another, because their direction will not be so often altered by encounters with other molecules. If the molecules in different parts of the medium are of different kinds, their progress from one part of the medium to another can be easily traced by analysing portions of the medium taken from different places. The rate of diffusion thus found furnishes one method of estimating the length of the free path of a molecule. This kind of diffusion goes on not only between the molecules of different gases, but among the molecules of the same gas, only in the latter case the results of the diffusion cannot be traced by analysis. But the diffusing molecules carry with them in their free paths the momentum and the energy which they happen at a given instant to have. The diffusion of momentum tends to equalise the apparent motion of different parts of the medium, and constitutes the phenomenon called the internal friction or viscosity of gases. The diffusion of energy tends to equalise the

temperature of different parts of the medium, and constitutes the phenomenon of the conduction of heat in gases.

These three phenomena—the diffusion of matter, of motion, and of heat in gases—have been experimentally investigated,—the diffusion of matter by Graham and Loschmidt, the diffusion of motion by Oscar Meyer and Clerk Maxwell, and that of heat by Stefan.

These three kinds of experiments give results which in the present imperfect state of the theory and the extreme difficulty of the experiments, especially those on the conduction of heat, may be regarded as tolerably consistent with each other. At the pressure of our atmosphere, and at the temperature of melting ice, the mean path of a molecule of hydrogen is about the 10,000th of a millimetre, or about the fifth part of a wave-length of green light. The mean path of the molecules of other gases is shorter than that of hydrogen.

The determination of the molecular volume of a gas is subject as yet to considerable uncertainty. The most obvious method is that of compressing the gas till it assumes the liquid form. It seems probable, from the great resistance of liquids to compression, that their molecules are at about the same distance from each other as that at which two molecules of the same substance in the gaseous form act on each other during an encounter. If this is the case, the molecular volume of a gas is somewhat less than the volume of the liquid into which it would be condensed by pressure, or, in other words, the density of the molecules is somewhat greater than that of the liquid.

Now, we know the relative weights of different molecules with great accuracy, and, from a knowledge of the mean path, we can calculate their relative diameters approximately. From these we can deduce the relative densities of different kinds of molecules. The relative densities so calculated have been compared by Lorenz Meyer with the observed densities of the liquids into which the gases may be condensed, and he finds a remarkable correspondence between them. There is considerable doubt, however, as to the relation between the molecules of a liquid and those of its vapour, so that till a larger number of comparisons have been made, we must not place too much reliance on the calculated densities of molecules. Another, and perhaps a more refined, method is that adopted by M. Van der Waals, who deduces the molecular volume from the deviations of the pressure from Boyle's law as the gas is compressed.

The first numerical estimate of the diameter of a molecule was that made by Loschmidt in 1865 from the mean path and the molecular volume. Independently of him and of each other, Mr Stoney, in 1868, and Sir W. Thomson, in 1870, published results of a similar kind—those of Thomson being deduced not only in this way, but from considerations derived from the thickness of soap bubbles, and from the electric action between zinc and copper.

The diameter and the mass of a molecule, as estimated by these methods, are, of course, very small, but by no means infinitely so. About two millions of molecules of hydrogen in a row would occupy a millimetre, and about two hundred million million million of them would weigh a milligramme. These numbers must be considered as exceedingly rough guesses; they must be corrected by more extensive and accurate experiments as science advances; but the main result, which appears to be well established, is that the determination of the mass of a molecule is a legitimate object of scientific research, and that this mass is by no means immeasurably small.

Loschmidt illustrates these molecular measurements by a comparison with the smallest magnitudes visible by means of a microscope. Nobert, he tells us, can draw 4000 lines in the breadth of a millimetre. The intervals between

these lines can be observed with a good microscope. A cube, whose side is the 4000th of a millimetre, may be taken as the *minimum visibile* for observers of the present day. Such a cube would contain from 60 to 100 million molecules of oxygen or of nitrogen; but since the molecules of organised substances contain on an average about 50 of the more elementary atoms, we may assume that the smallest organised particle visible under the microscope contains about two million molecules of organic matter. At least half of every living organism consists of water, so that the smallest living being visible under the microscope does not contain more than about a million organic molecules. Some exceedingly simple organisms may be supposed built up of not more than a million similar molecules. It is impossible, however, to conceive so small a number sufficient to form a being furnished with a whole system of specialised organs.

Thus molecular science sets us face to face with physiological theories. It forbids the physiologist from imagining that structural details of infinitely small dimensions can furnish an explanation of the infinite variety which exists in the properties and functions of the most minute organisms.

A microscopic germ is, we know, capable of development into a highly organised animal. Another germ, equally microscopic, becomes, when developed, an animal of a totally different kind. Do all the differences, infinite in number, which distinguish the one animal from the other, arise each from some difference in the structure of the respective germs? Even if we admit this as possible, we shall be called upon by the advocates of Pangenesis to admit still greater marvels. For the microscopic germ, according to this theory, is no mere individual, but a representative body, containing members collected from every rank of the long-drawn ramification of the ancestral tree, the number of these members being amply sufficient not only to furnish the hereditary characteristics of every organ of the body and every habit of the animal from birth to death, but also to afford a stock of latent gemmules to be passed on in an inactive state from germ to germ, till at last the ancestral peculiarity which it represents is revived in some remote descendant.

Some of the exponents of this theory of heredity have attempted to elude the difficulty of placing a whole world of wonders within a body so small and so devoid of visible structure as a germ, by using the phrase structureless germs.<sup>1</sup> Now, one material system can differ from another only in the configuration and motion which it has at a given instant. To explain differences of function and development of a germ without assuming differences of structure is, therefore, to admit that the properties of a germ are not those of a purely material system.

The evidence as to the nature and motion of molecules, with which we have hitherto been occupied, has been derived from experiments upon gaseous media, the smallest sensible portion of which contains millions of millions of molecules. The constancy and uniformity of the properties of the gaseous medium is the direct result of the inconceivable irregularity of the motion of agitation of its molecules. Any cause which could introduce regularity into the motion of agitation, and marshal the molecules into order and method in their evolutions, might check or even reverse that tendency to diffusion of matter, motion, and energy, which is one of the most invariable phenomena of nature, and to which Thomson has given the name of the dissipation of energy.

Thus, when a sound-wave is passing through a mass of

air, this motion is of a certain definite type, and if left to itself the whole motion is passed on to other masses of air, and the sound-wave passes on, leaving the air behind it at rest. Heat, on the other hand, never passes out of a hot body except to enter a colder body, so that the energy of sound-waves, or any other form of energy which is propagated so as to pass wholly out of one portion of the medium and into another, cannot be called heat.

We have now to turn our attention to a class of molecular motions, which are as remarkable for their regularity as the motion of agitation is for its irregularity.

It has been found, by means of the spectrocope, that the light emitted by incandescent substances is different according to their state of condensation. When they are in an extremely rarefied condition the spectrum of their light consists of a set of sharply-defined bright lines. As the substance approaches a denser condition the spectrum tends to become continuous, either by the lines becoming broader and less defined, or by new lines and bands appearing between them, till the spectrum at length loses all its characteristics and becomes identical with that of solid bodies when raised to the same temperature.

Hence the vibrating systems, which are the source of the emitted light, must be vibrating in a different manner in these two cases. When the spectrum consists of a number of bright lines, the motion of the system must be compounded of a corresponding number of types of harmonic vibration.

In order that a bright line may be sharply defined, the vibratory motion which produces it must be kept up in a perfectly regular manner for some hundreds or thousands of vibrations. If the motion of each of the vibrating bodies is kept up only during a small number of vibrations, then, however regular may be the vibrations of each body while it lasts, the resultant disturbance of the luminiferous medium, when analysed by the prism, will be found to contain, besides the part due to the regular vibrations, other motions, depending on the starting and stopping of each particular vibrating body, which will become manifest as a diffused luminosity scattered over the whole length of the spectrum. A spectrum of bright lines, therefore, indicates that the vibrating bodies when set in motion are allowed to vibrate in accordance with the conditions of their internal structure for some time before they are again interfered with by external forces.

It appears, therefore, from spectroscopic evidence that each molecule of a rarefied gas is, during the greater part of its existence, at such a distance from all other molecules that it executes its vibrations in an undisturbed and regular manner. This is the same conclusion to which we were led by considerations of another kind at p. 39.

We may therefore regard the bright lines in the spectrum of a gas as the result of the vibrations executed by the molecules while describing their free paths. When two molecules separate from one another, after an encounter, each of them is in a state of vibration, arising from the unequal action on different parts of the same molecule during the encounter. Hence, though the centre of mass of the molecule describing its free path moves with uniform velocity, the parts of the molecule have a vibratory motion with respect to the centre of mass of the whole molecule, and it is the disturbance of the luminiferous medium communicated to it by the vibrating molecules which constitutes the emitted light.

We may compare the vibrating molecule to a bell. When struck, the bell is set in motion. This motion is compounded of harmonic vibrations of many different periods, each of which acts on the air, producing notes of as many different pitches. As the bell communicates its motion to the air, these vibrations necessarily decay, some

<sup>1</sup> See F. Galton, "On Blood Relationship," *Proc. Roy. Soc.*, June 13, 1872.

of them faster than others, so that the sound contains fewer and fewer notes, till at last it is reduced to the fundamental note of the bell.<sup>1</sup> If we suppose that there are a great many bells precisely similar to each other, and that they are struck, first one and then another, in a perfectly irregular manner, yet so that, on an average, as many bells are struck in one second of time as in another, and also in such a way that, on an average, any one bell is not again struck till it has ceased to vibrate, then the audible result will appear a continuous sound, composed of the sound emitted by bells in all states of vibration, from the clang of the actual stroke to the final hum of the dying fundamental tone.

But now let the number of bells be reduced while the same number of strokes are given in a second. Each bell will now be struck before it has ceased to vibrate, so that in the resulting sound there will be less of the fundamental tone and more of the original clang, till at last, when the peal is reduced to one bell, on which innumerable hammers are continually plying their strokes all out of time, the sound will become a mere noise, in which no musical note can be distinguished.

In the case of a gas we have an immense number of molecules, each of which is set in vibration when it encounters another molecule, and continues to vibrate as it describes its free path. The molecule is a material system, the parts of which are connected in some definite way, and from the fact that the bright lines of the emitted light have always the same wave-lengths, we learn that the vibrations corresponding to these lines are always executed in the same periodic time, and therefore the force tending to restore any part of the molecule to its position of equilibrium in the molecule must be proportional to its displacement relative to that position.

From the mathematical theory of the motion of such a system, it appears that the whole motion may be analysed into the following parts, which may be considered each independently of the others:—In the first place, the centre of mass of the system moves with uniform velocity in a straight line. This velocity may have any value. In the second place, there may be a motion of rotation, the angular momentum of the system about its centre of mass remaining during the free path constant in magnitude and direction. This angular momentum may have any value whatever, and its axis may have any direction. In the third place, the remainder of the motion is made up of a number of component motions, each of which is an harmonic vibration of a given type. In each type of vibration the periodic time of vibration is determined by the nature of the system, and is invariable for the same system. The relative amount of motion in different parts of the system is also determinate for each type, but the absolute amount of motion and the phase of the vibration of each type are determined by the particular circumstances of the last encounter, and may vary in any manner from one encounter to another.

The values of the periodic times of the different types of vibration are given by the roots of a certain equation, the form of which depends on the nature of the connections of the system. In certain exceptionally simple cases, as, for instance, in that of a uniform string stretched between two fixed points, the roots of the equation are connected by simple arithmetical relations, and if the internal structure of a molecule had an analogous kind of simplicity, we might expect to find in the spectrum of the molecule a

series of bright lines, whose wave-lengths are in simple arithmetical ratios.

But if we suppose the molecule to be constituted according to some different type, as, for instance, if it is an elastic sphere, or if it consists of a finite number of atoms kept in their places by attractive and repulsive forces, the roots of the equation will not be connected with each other by any simple relations, but each may be made to vary independently of the others by a suitable change of the connections of the system. Hence, we have no right to expect any definite numerical relations among the wave-lengths of the bright lines of a gas.

The bright lines of the spectrum of an incandescent gas are therefore due to the harmonic vibrations of the molecules of the gas during their free paths. The only effect of the motion of the centre of mass of the molecule is to alter the time of vibration of the light as received by a stationary observer. When the molecule is coming towards the observer, each successive impulse will have a shorter distance to travel before it reaches his eye, and therefore the impulses will appear to succeed each other more rapidly than if the molecule were at rest, and the contrary will be the case if the molecule is receding from the observer. The bright line corresponding to the vibration will therefore be shifted in the spectrum towards the blue end when the molecule is approaching, and towards the red end when it is receding from the observer. By observations of the displacement of certain lines in the spectrum, Dr Huggins and others have measured the rate of approach or of recession of certain stars with respect to the earth, and Mr Lockyer has determined the rate of motion of tornadoes in the sun. But Lord Rayleigh has pointed out that according to the dynamical theory of gases the molecules are moving hither and thither with so great velocity that, however narrow and sharply-defined any bright line due to a single molecule may be, the displacement of the line towards the blue by the approaching molecules, and towards the red by the receding molecules, will produce a certain amount of widening and blurring of the line in the spectrum, so that there is a limit to the sharpness of definition of the lines of a gas. The widening of the lines due to this cause will be in proportion to the velocity of agitation of the molecules. It will be greatest for the molecules of smallest mass, as those of hydrogen, and it will increase with the temperature. Hence the measurement of the breadth of the hydrogen lines, such as C or F in the spectrum of the solar prominences, may furnish evidence that the temperature of the sun cannot exceed a certain value.

#### ON THE THEORY OF VORTEX ATOMS.

The equations which form the foundations of the mathematical theory of fluid motion were fully laid down by Lagrange and the great mathematicians of the end of last century, but the number of solutions of cases of fluid motion which had been actually worked out remained very small, and almost all of these belonged to a particular type of fluid motion, which has been since named the irrotational type. It had been shown, indeed, by Lagrange, that a perfect fluid, if its motion is at any time irrotational, will continue in all time coming to move in an irrotational manner, so that, by assuming that the fluid was at one time at rest, the calculation of its subsequent motion may be very much simplified.

It was reserved for Helmholtz to point out the very remarkable properties of rotational motion in a homogeneous incompressible fluid devoid of all viscosity. We must first define the physical properties of such a fluid. In the first place, it is a material substance. Its motion is

<sup>1</sup> Part of the energy of motion is, in the case of the bell, dissipated in the substance of the bell in virtue of the viscosity of the metal, and assumes the form of heat, but it is not necessary, for the purpose of illustration, to take this cause of the decay of vibrations into account.

continuous in space and time, and if we follow any portion of it as it moves, the mass of that portion remains invariable. These properties it shares with all material substances. In the next place, it is incompressible. The form of a given portion of the fluid may change, but its volume remains invariable; in other words, the density of the fluid remains the same during its motion. Besides this, the fluid is homogeneous, or the density of all parts of the fluid is the same. It is also continuous, so that the mass of the fluid contained within any closed surface is always exactly proportional to the volume contained within that surface. This is equivalent to asserting that the fluid is not made up of molecules; for, if it were, the mass would vary in a discontinuous manner as the volume increases continuously, because first one and then another molecule would be included within the closed surface. Lastly, it is a perfect fluid, or, in other words, the stress between one portion and a contiguous portion is always normal to the surface which separates these portions, and this whether the fluid is at rest or in motion.

We have seen that in a molecular fluid the interdiffusion of the molecules causes an interdiffusion of motion of different parts of the fluid, so that the action between contiguous parts is no longer normal but in a direction tending to diminish their relative motion. Hence the perfect fluid cannot be molecular.

All that is necessary in order to form a correct mathematical theory of a material system is that its properties shall be clearly defined and shall be consistent with each other. This is essential; but whether a substance having such properties actually exists is a question which comes to be considered only when we propose to make some practical application of the results of the mathematical theory. The properties of our perfect liquid are clearly defined and consistent with each other, and from the mathematical theory we can deduce remarkable results, some of which may be illustrated in a rough way by means of fluids which are by no means perfect in the sense of not being viscous, such, for instance, as air and water.

The motion of a fluid is said to be irrotational when it is such that if a spherical portion of the fluid were suddenly solidified, the solid sphere so formed would not be rotating about any axis. When the motion of the fluid is rotational the axis and angular velocity of the rotation of any small part of the fluid are those of a small spherical portion suddenly solidified.

The mathematical expression of these definitions is as follows:—Let  $u, v, w$  be the components of the velocity of the fluid at the point  $(x, y, z)$ , and let

$$\alpha = \frac{dv}{dz} - \frac{dw}{dy}, \quad \beta = \frac{dw}{dx} - \frac{du}{dz}, \quad \gamma = \frac{du}{dy} - \frac{dv}{dx} \quad (1),$$

then  $\alpha, \beta, \gamma$  are the components of the velocity of rotation of the fluid at the point  $(x, y, z)$ . The axis of rotation is in the direction of the resultant of  $\alpha, \beta,$  and  $\gamma,$  and the velocity of rotation,  $\omega,$  is measured by this resultant.

A line drawn in the fluid, so that at every point of the line

$$\frac{1}{\alpha} \frac{dx}{ds} = \frac{1}{\beta} \frac{dy}{ds} = \frac{1}{\gamma} \frac{dz}{ds} = \frac{1}{\omega} \quad (2),$$

where  $s$  is the length of the line up to the point  $x, y, z,$  is called a vortex line. Its direction coincides at every point with that of the axis of rotation of the fluid.

We may now prove the theorem of Helmholtz, that the points of the fluid which at any instant lie in the same vortex line continue to lie in the same vortex line during the whole motion of the fluid.

The equations of motion of a fluid are of the form

$$\rho \frac{du}{dt} + \frac{dp}{dx} + \rho \frac{dV}{dx} = 0 \quad (3),$$

when  $\rho$  is the density, which in the case of our homogeneous incompressible fluid we may assume to be unity, the operator  $\frac{d}{dt}$  represents the rate of variation of the symbol to which it is prefixed at a point which is carried forward with the fluid, so that

$$\frac{du}{dt} = \frac{du}{dt} + u \frac{du}{dx} + v \frac{du}{dy} + w \frac{du}{dz} \quad (4),$$

$p$  is the pressure, and  $V$  is the potential of external forces. There are two other equations of similar form in  $y$  and  $z$ . Differentiating the equation in  $y$  with respect to  $z,$  and that in  $z$  with respect to  $y,$  and subtracting the second from the first, we find

$$\frac{d}{ds} \frac{dv}{dt} - \frac{d}{dy} \frac{dw}{dt} = 0 \quad (5).$$

Performing the differentiations and remembering equations (1) and also the condition of incompressibility,

$$\frac{du}{dx} + \frac{dv}{dy} + \frac{dw}{dz} = 0 \quad (6),$$

we find

$$\frac{d\alpha}{dt} = \alpha \frac{du}{dx} + \beta \frac{du}{dy} + \gamma \frac{du}{dz} \quad (7).$$

Now, let us suppose a vortex line drawn in the fluid so as always to begin at the same particle of the fluid. The components of the velocity of this point are  $u, v, w.$  Let us find those of a point on the moving vortex line at a distance  $ds$  from this point where

$$ds = u dx + v dy + w dz \quad (8).$$

The co-ordinates of this point are

$$x + \alpha ds, \quad y + \beta ds, \quad z + \gamma ds \quad (9),$$

and the components of its velocity are

$$u + \frac{d\alpha}{dt} ds + v + \frac{d\beta}{dt} ds, \quad w + \frac{d\gamma}{dt} ds \quad (10).$$

Consider the first of these components. In virtue of equation (7) we may write it

$$u + \frac{d\alpha}{dx} \alpha ds + \frac{d\alpha}{dy} \beta ds + \frac{d\alpha}{dz} \gamma ds \quad (11),$$

or

$$u + \frac{d\alpha}{dx} \frac{dx}{ds} ds + \frac{d\alpha}{dy} \frac{dy}{ds} ds + \frac{d\alpha}{dz} \frac{dz}{ds} ds \quad (12),$$

or

$$u + \frac{d\alpha}{ds} ds \quad (13).$$

But this represents the value of the component  $u$  of the velocity of the fluid itself at the same point, and the same thing may be proved of the other components.

Hence the velocity of the second point on the vortex line is identical with that of the fluid at that point. In other words, the vortex line swims along with the fluid, and is always formed of the same row of fluid particles. The vortex line is therefore no mere mathematical symbol, but has a physical existence continuous in time and space.

By differentiating equations (1) with respect to  $x, y,$  and  $z$  respectively, and adding the results, we obtain the equation—

$$\frac{d\alpha}{dx} + \frac{d\beta}{dy} + \frac{d\gamma}{dz} = 0 \quad (14).$$

This is an equation of the same form with (6), which expresses the condition of flow of a fluid of invariable density. Hence, if we imagine a fluid, quite independent of the original fluid, whose components of velocity are  $\alpha, \beta, \gamma,$  this imaginary fluid will flow without altering its density.

Now, consider a closed curve in space, and let vortex



lines be drawn in both directions from every point of this curve. These vortex lines will form a tubular surface, which is called a vortex tube or a vortex filament. Since the imaginary fluid flows along the vortex lines without change of density, the quantity which in unit of time flows through any section of the same vortex tube must be the same. Hence, at any section of a vortex tube the product of the area of the section into the mean velocity of rotation is the same. This quantity is called the *strength* of the vortex tube.

A vortex tube cannot begin or end within the fluid; for, if it did, the imaginary fluid, whose velocity components are  $\alpha, \beta, \gamma$ , would be generated from nothing at the beginning of the tube, and reduced to nothing at the end of it. Hence, if the tube has a beginning and an end, they must lie on the surface of the fluid mass. If the fluid is infinite the vortex tube must be infinite, or else it must return into itself.

We have thus arrived at the following remarkable theorems relating to a finite vortex tube in an infinite fluid:—(1.) It returns into itself, forming a closed ring. We may therefore describe it as a vortex ring. (2.) It always consists of the same portion of the fluid. Hence its volume is invariable. (3.) Its strength remains always the same. Hence the velocity of rotation at any section varies inversely as the area of that section, and that of any segment varies directly as the length of that segment. (4.) No part of the fluid which is not originally in a state of rotational motion can ever enter into that state, and no part of the fluid whose motion is rotational can ever cease to move rotationally. (5.) No vortex tube can ever pass through any other vortex tube, or through any of its own convolutions. Hence, if two vortex tubes are linked together, they can never be separated, and if a single vortex tube is knotted on itself, it can never become unknotted. (6.) The motion at any instant of every part of the fluid, including the vortex rings themselves, may be accurately represented by conceiving an electric current to occupy the place of each vortex ring, the strength of the current being proportional to that of the ring. The magnetic force at any point of space will then represent in direction and magnitude the velocity of the fluid at the corresponding point of the fluid.

These properties of vortex rings suggested to Sir William Thomson<sup>1</sup> the possibility of founding on them a new form of the atomic theory. The conditions which must be satisfied by an atom are—permanence in magnitude, capability of internal motion or vibration, and a sufficient amount of possible characteristics to account for the difference between atoms of different kinds.

The small hard body imagined by Lucretius, and adopted by Newton, was invented for the express purpose of accounting for the permanence of the properties of bodies. But it fails to account for the vibrations of a molecule as revealed by the spectroscope. We may indeed suppose the atom elastic, but this is to endow it with the very property for the explanation of which, as exhibited in aggregate bodies, the atomic constitution was originally assumed. The massive centres of force imagined by Boscovich may have more to recommend them to the mathematician, who has no scruple in supposing them to be invested with the power of attracting and repelling according to any law of the distance which it may please him to assign. Such centres of force are no doubt in their own nature indivisible, but then they are also, singly, incapable of vibration. To obtain vibrations we must imagine molecules consisting of many such centres, but, in so doing, the possibility of these centres being separated altogether is again introduced.

Besides, it is in questionable scientific taste, after using atoms so freely to get rid of forces acting at sensible distances, to make the whole function of the atoms an action at insensible distances.

On the other hand, the vortex ring of Helmholtz, imagined as the true form of the atom by Thomson, satisfies more of the conditions than any atom hitherto imagined. In the first place, it is quantitatively permanent, as regards its volume and its strength,—two independent quantities. It is also qualitatively permanent as regards its degree of implication, whether “knottedness” on itself or “linkedness” with other vortex rings. At the same time, it is capable of infinite changes of form, and may execute vibrations of different periods, as we know that molecules do. And the number of essentially different implications of vortex rings may be very great without supposing the degree of implication of any of them very high.

But the greatest recommendation of this theory, from a philosophical point of view, is that its success in explaining phenomena does not depend on the ingenuity with which its contrivers “save appearances,” by introducing first one hypothetical force and then another. When the vortex atom is once set in motion, all its properties are absolutely fixed and determined by the laws of motion of the primitive fluid, which are fully expressed in the fundamental equations. The disciple of Lucretius may cut and carve his solid atoms in the hope of getting them to combine into worlds; the follower of Boscovich may imagine new laws of force to meet the requirements of each new phenomenon; but he who dares to plant his feet in the path opened up by Helmholtz and Thomson has no such resources. His primitive fluid has no other properties than inertia, invariable density, and perfect mobility, and the method by which the motion of this fluid is to be traced is pure mathematical analysis. The difficulties of this method are enormous, but the glory of surmounting them would be unique.

There seems to be little doubt that an encounter between two vortex atoms would be in its general character similar to those which we have already described. Indeed, the encounter between two smoke rings in air gives a very lively illustration of the elasticity of vortex rings.

But one of the first, if not the very first desideratum in a complete theory of matter is to explain—first, mass, and second, gravitation. To explain mass may seem an absurd achievement. We generally suppose that it is of the essence of matter to be the receptacle of momentum and energy, and even Thomson, in his definition of his primitive fluid, attributes to it the possession of mass. But according to Thomson, though the primitive fluid is the only true matter, yet that which we call matter is not the primitive fluid itself, but a mode of motion of that primitive fluid. It is the mode of motion which constitutes the vortex rings, and which furnishes us with examples of that permanence and continuity of existence which we are accustomed to attribute to matter itself. The primitive fluid, the only true matter, entirely eludes our perceptions when it is not endued with the mode of motion which converts certain portions of it into vortex rings, and thus renders it molecular.

In Thomson's theory, therefore, the mass of bodies requires explanation. We have to explain the inertia of what is only a mode of motion, and inertia is a property of matter, not of modes of motion. It is true that a vortex ring at any given instant has a definite momentum and a definite energy, but to show that bodies built up of vortex rings would have such momentum and energy as we know them to have is, in the present state of the theory, a very difficult task.

It may seem hard to say of an infant theory that it is bound to explain gravitation. Since the time of Newton,

<sup>1</sup> “On Vortex Atoms,” *Proc. Roy. Soc. Edin.*, 18th February 1867.

the doctrine of gravitation has been admitted and expounded, till it has gradually acquired the character rather of an ultimate fact than of a fact to be explained.

It seems doubtful whether Lucretius considers gravitation to be an essential property of matter, as he seems to assert in the very remarkable lines—

“ Nam et tantundem est in laus glomera, quantum  
Corporis in plumbo est, tantundem pendere par est;  
Corporis officium est quoniam premere omnia deorsum.”  
—*De Rerum Natura*, l. 261.

If this is the true opinion of Lucretius, and if the downward flight of the atoms arises, in his view, from their own gravity, it seems very doubtful whether he attributed the weight of sensible bodies to the impact of the atoms. The latter opinion is that of Le Sage, of Geneva, propounded in his *Lucrèce Newtonien*, and in his *Traité de Physique Mécanique*, published, along with a second treatise of his own, by Pierre Prevost, of Geneva, in 1818.<sup>1</sup> The theory of Le Sage is that the gravitation of bodies towards each other is caused by the impact of streams of atoms flying in all directions through space. These atoms he calls ultramundane corpuscles, because he conceives them to come in all directions from regions far beyond that part of the system of the world which is in any way known to us. He supposes each of them to be so small that a collision with another ultramundane corpuscle is an event of very rare occurrence. It is by striking against the molecules of gross matter that they discharge their function of drawing bodies towards each other. A body placed by itself in free space and exposed to the impacts of these corpuscles would be banded about by them in all directions, but because, on the whole, it receives as many blows on one side as on another, it cannot thereby acquire any sensible velocity. But if there are two bodies in space, each of them will screen the other from a certain proportion of the corpuscular bombardment, so that a smaller number of corpuscles will strike either body on that side which is next the other body, while the number of corpuscles which strike it in other directions remains the same.

Each body will therefore be urged towards the other by the effect of the excess of the impacts it receives on the side furthest from the other. If we take account of the impacts of those corpuscles only which come directly from infinite space, and leave out of consideration those which have already struck mundane bodies, it is easy to calculate the result on the two bodies, supposing their dimensions small compared with the distance between them.

The force of attraction would vary directly as the product of the areas of the sections of the bodies taken normal to the distance and inversely as the square of the distance between them.

Now, the attraction of gravitation varies as the product of the masses of the bodies between which it acts, and inversely as the square of the distance between them. If, then, we can imagine a constitution of bodies such that the effective areas of the bodies are proportional to their masses, we shall make the two laws coincide. Here, then, seems to be a path leading towards an explanation of the law of gravitation, which, if it can be shown to be in other respects consistent with facts, may turn out to be a royal road into the very arcana of science.

Le Sage himself shows that, in order to make the effective area of a body, in virtue of which it acts as a screen to the streams of ultramundane corpuscles, proportional to the mass of the body, whether the body be large or small, we must admit that the size of the solid atoms of the body is exceedingly small compared with the distances between

them, so that a very small proportion of the corpuscles are stopped even by the densest and largest bodies. We may picture to ourselves the streams of corpuscles coming in every direction, like light from a uniformly illuminated sky. We may imagine a material body to consist of a congeries of atoms at considerable distances from each other, and we may represent this by a swarm of insects flying in the air. To an observer at a distance this swarm will be visible as a slight darkening of the sky in a certain quarter. This darkening will represent the action of the material body in stopping the flight of the corpuscles. Now, if the proportion of light stopped by the swarm is very small, two such swarms will stop nearly the same amount of light, whether they are in a line with the eye or not, but if one of them stops an appreciable proportion of light, there will not be so much left to be stopped by the other, and the effect of two swarms in a line with the eye will be less than the sum of the two effects separately.

Now, we know that the effect of the attraction of the sun and earth on the moon is not appreciably different when the moon is eclipsed than on other occasions when full moon occurs without an eclipse. This shows that the number of the corpuscles which are stopped by bodies of the size and mass of the earth, and even the sun, is very small compared with the number which pass straight through the earth or the sun without striking a single molecule. To the streams of corpuscles the earth and the sun are mere systems of atoms scattered in space, which present far more openings than obstacles to their rectilinear flight.

Such is the ingenious doctrine of Le Sage, by which he endeavours to explain universal gravitation. Let us try to form some estimate of this continual bombardment of ultramundane corpuscles which is being kept up on all sides of us.

We have seen that the sun stops but a very small fraction of the corpuscles which enter it. The earth, being a smaller body, stops a still smaller proportion of them. The proportion of those which are stopped by a small body, say a 1 lb shot, must be smaller still in an enormous degree, because its thickness is exceedingly small compared with that of the earth.

Now, the weight of the ball, or its tendency towards the earth, is produced, according to this theory, by the excess of the impacts of the corpuscles which come from above over the impacts of those which come from below, and have passed through the earth. Either of these quantities is an exceedingly small fraction of the momentum of the whole number of corpuscles which pass through the ball in a second, and their difference is a small fraction of either, and yet it is equivalent to the weight of a pound. The velocity of the corpuscles must be enormously greater than that of any of the heavenly bodies, otherwise, as may easily be shown, they would act as a resisting medium opposing the motion of the planets. Now, the energy of a moving system is half the product of its momentum into its velocity. Hence the energy of the corpuscles, which by their impacts on the ball during one second urge it towards the earth, must be a number of foot-pounds equal to the number of feet over which a corpuscule travels in a second. That is to say, not less than thousands of millions. But this is only a small fraction of the energy of all the impacts which the atoms of the ball receive from the innumerable streams of corpuscles which fall upon it in all directions.

Hence the rate at which the energy of the corpuscles is spent in order to maintain the gravitating property of a single pound, is at least millions of millions of foot-pounds per second.

What becomes of this enormous quantity of energy? If the corpuscles, after striking the atoms, fly off with a

<sup>1</sup> See also *Constitution de la Matière*, &c., par le P. Lera, Paris, 1869.

velocity equal to that which they had before, they will carry their energy away with them into the ultramundane regions. But if this be the case, then the corpuscles rebounding from the body in any given direction will be both in number and in velocity exactly equivalent to those which are prevented from proceeding in that direction by being deflected by the body, and it may be shown that this will be the case whatever be the shape of the body, and however many bodies may be present in the field. Thus, the rebounding corpuscles exactly make up for those which are deflected by the body, and there will be no excess of the impacts on any other body in one direction or another.

The explanation of gravitation, therefore, falls to the ground if the corpuscles are like perfectly elastic spheres, and rebound with a velocity of separation equal to that of approach. If, on the other hand, they rebound with a smaller velocity, the effect of attraction between the bodies will no doubt be produced, but then we have to find what becomes of the energy which the molecules have brought with them but have not carried away.

If any appreciable fraction of this energy is communicated to the body in the form of heat, the amount of heat so generated would in a few seconds raise it, and in like manner the whole material universe, to a white heat.

It has been suggested by Sir W. Thomson that the corpuscles may be so constructed so to carry off their energy with them, provided that part of their kinetic energy is transformed, during impact, from energy of translation to energy of rotation or vibration. For this purpose the corpuscles must be material systems, not mere points. Thomson suggests that they are vortex atoms, which are set into a state of vibration at impact, and go off with a smaller velocity of translation, but in a state of violent vibration. He has also suggested the possibility of the vortex corpuscle regaining its swiftness and losing part of its vibratory agitation by communion with its kindred corpuscles in infinite space.

We have devoted more space to this theory than it seems to deserve, because it is ingenious, and because it is the only theory of the cause of gravitation which has been so far developed as to be capable of being attacked and defended. It does not appear to us that it can account for the temperature of bodies remaining moderate while their atoms are exposed to the bombardment. The temperature of bodies must tend to approach that at which the average kinetic energy of a molecule of the body would be equal to the average kinetic energy of an ultramundane corpuscle.

Now, suppose a plane surface to exist which stops all the corpuscles. The pressure on this plane will be  $p = NMu^2$  where  $M$  is the mass of a corpuscle,  $N$  the number in unit of volume, and  $u$  its velocity normal to the plane. Now, we know that the very greatest pressure existing in the universe must be much less than the pressure  $p$ , which would be exerted against a body which stops all the corpuscles. We are also tolerably certain that  $N$ , the number of corpuscles which are at any one time within unit of volume, is small compared with the value of  $N$  for the molecules of ordinary bodies. Hence,  $Mu^2$  must be enormous compared with the corresponding quantity for ordinary bodies, and it follows that the impact of the corpuscles would raise all bodies to an enormous temperature. We may also observe that according to this theory the habitable universe, which we are accustomed to regard as the scene of a magnificent illustration of the conservation of energy as the fundamental principle of all nature, is in reality maintained in working order only by an enormous expenditure of external power, which would be nothing less than ruinous if the supply were drawn from anywhere else than from the infinitude of space, and which, if the contrivances of the most eminent mathematicians should be

found in any respect defective, might at any moment tear the whole universe atom from atom.

We must now leave these speculations about the nature of molecules and the cause of gravitation, and contemplate the material universe as made up of molecules. Every molecule, so far as we know, belongs to one of a definite number of species. The list of chemical elements may be taken as representing the known species which have been examined in the laboratories. Several of these have been discovered by means of the spectroscope, and more may yet remain to be discovered in the same way. The spectroscope has also been applied to analyse the light of the sun, the brighter stars, and some of the nebulae and comets, and has shown that the character of the light emitted by these bodies is similar in some cases to that emitted by terrestrial molecules, and in others to light from which the molecules have absorbed certain rays. In this way a considerable number of coincidences have been traced between the systems of lines belonging to particular terrestrial substances and corresponding lines in the spectra of the heavenly bodies.

The value of the evidence furnished by such coincidences may be estimated by considering the degree of accuracy with which one such coincidence may be observed. The interval between the two lines which form Fraunhofer's line D is about the five hundredth part of the interval between B and G on Kirchhoff's scale. A discordance between the positions of two lines amounting to the tenth part of this interval, that is to say, the five thousandth part of the length of the bright part of the spectrum, would be very perceptible in a spectroscope of moderate power. We may define the power of the spectroscope to be the number of times which the smallest measurable interval is contained in the length of the visible spectrum. Let us denote this by  $p$ . In the case we have supposed  $p$  will be about 5000.

If the spectrum of the sun contains  $n$  lines of a certain degree of intensity, the probability that any one line of the spectrum of a gas will coincide with one of these  $n$  lines is

$$1 - \left(1 - \frac{1}{p}\right)^n = \frac{n}{p} \left(1 - \frac{n-1}{2} \frac{1}{p} + \dots\right),$$

and when  $p$  is large compared with  $n$ , this becomes nearly  $\frac{n}{p}$ . If there are  $r$  lines in the spectrum of the gas, the probability that each and every one shall coincide with a line in the solar spectrum is approximately  $\frac{n^r}{p^r}$ .

Hence, in the case of a gas whose spectrum contains several lines, we have to compare the results of two hypotheses. If a large amount of the gas exists in the sun, we have the strongest reason for expecting to find all the  $r$  lines in the solar spectrum. If it does not exist, the probability that  $r$  lines out of the  $n$  observed lines shall coincide with the lines of the gas is exceedingly small. If, then, we find all the  $r$  lines in their proper places in the solar spectrum, we have very strong grounds for believing that the gas exists in the sun. The probability that the gas exists in the sun is greatly strengthened if the character of the lines as to relative intensity and breadth is found to correspond in the two spectra.

The absence of one or more lines of the gas in the solar spectrum tends of course to weaken the probability, but the amount to be deducted from the probability must depend on what we know of the variation in the relative intensity of the lines when the temperature and the pressure of the gas are made to vary.

Coincidences observed, in the case of several terrestrial substances, with several systems of lines in the spectra of the heavenly bodies, tend to increase the evidence for the

doctrine that terrestrial substances exist in the heavenly bodies, while the discovery of particular lines in a celestial spectrum which do not coincide with any line in a terrestrial spectrum does not much weaken the general argument, but rather indicates either that a substance exists in the heavenly body not yet detected by chemists on earth, or that the temperature of the heavenly body is such that some substance, undecomposable by our methods, is there split up into components unknown to us in their separate state.

We are thus led to believe that in widely-separated parts of the visible universe molecules exist of various kinds, the molecules of each kind having their various periods of vibration either identical, or so nearly identical that our spectroscopes cannot distinguish them. We might argue from this that these molecules are alike in all other respects, as, for instance, in mass. But it is sufficient for our present purpose to observe that the same kind of molecule, say that of hydrogen, has the same set of periods of vibration, whether we procure the hydrogen from water, from coal, or from meteoric iron, and that light, having the same set of periods of vibration, comes to us from the sun, from Sirius, and from Arcturus.

The same kind of reasoning which led us to believe that hydrogen exists in the sun and stars, also leads us to believe that the molecules of hydrogen in all these bodies had a common origin. For a material system capable of vibration may have for its periods of vibration any set of values whatever. The probability, therefore, that two material systems, quite independent of each other, shall have, to the degree of accuracy of modern spectroscopic measurements, the same set of periods of vibration, is so very small that we are forced to believe that the two systems are not independent of each other. When, instead of two such systems, we have innumerable multitudes all having the same set of periods, the argument is immensely strengthened.

Admitting, then, that there is a real relation between any two molecules of hydrogen, let us consider what this relation may be.

We may conceive of a mutual action between one body and another tending to assimilate them. Two clocks, for instance, will keep time with each other if connected by a wooden rod, though they have different rates if they were disconnected. But even if the properties of a molecule were as capable of modification as those of a clock, there is no physical connection of a sufficient kind between Sirius and Arcturus.

There are also methods by which a large number of bodies differing from each other may be sorted into sets, so that those in each set more or less resemble each other. In the manufacture of small shot this is done by making the shot roll down an inclined plane. The largest specimens acquire the greatest velocities, and are projected farther than the smaller ones. In this way the various pellets, which differ both in size and in roundness, are sorted into different kinds, those belonging to each kind being nearly of the same size, and those which are not tolerably spherical being rejected altogether.

If the molecules were originally as various as these leaden pellets, and were afterwards sorted into kinds, we should have to account for the disappearance of all the molecules which did not fall under one of the very limited number of kinds known to us; and to get rid of a number of indestructible bodies, exceeding by far the number of the molecules of all the recognised kinds, would be one of the severest labours ever proposed to a cosmogonist.

It is well known that living beings may be grouped into a certain number of species, defined with more or less precision, and that it is difficult or impossible to find a series of individuals forming the links of a continuous chain between one species and another. In the case of living beings,

however, the generation of individuals is always going on, each individual differing more or less from its parents. Each individual during its whole life is undergoing modification, and it either survives and propagates its species, or dies early, accordingly as it is more or less adapted to the circumstances of its environment. Hence, it has been found possible to frame a theory of the distribution of organisms into species by means of generation, variation, and discriminative destruction. But a theory of evolution of this kind cannot be applied to the case of molecules, for the individual molecules neither are born nor die, they have neither parents nor offspring, and so far from being modified by their environment, we find that two molecules of the same kind, say of hydrogen, have the same properties, though one has been compounded with carbon and buried in the earth as coal for untold ages, while the other has been "occluded" in the iron of a meteorite, and after unknown wanderings in the heavens has at last fallen into the hands of some terrestrial chemist.

The process by which the molecules become distributed into distinct species is not one of which we know any instances going on at present, or of which we have as yet been able to form any mental representation. If we suppose that the molecules known to us are built up each of some moderate number of atoms, these atoms being all of them exactly alike, then we may attribute the limited number of molecular species to the limited number of ways in which the primitive atoms may be combined so as to form a permanent system.

But though this hypothesis gets rid of the difficulty of accounting for the independent origin of different species of molecules, it merely transfers the difficulty from the known molecules to the primitive atoms. How did the atoms come to be all alike in those properties which are in themselves capable of assuming any value?

If we adopt the theory of Boecovich, and assert that the primitive atom is a mere centre of force, having a certain definite mass, we may get over the difficulty about the equality of the mass of all atoms by laying it down as a doctrine which cannot be disproved by experiment, that mass is not a quantity capable of continuous increase or diminution, but that it is in its own nature discontinuous, like number, the atom being the unit, and all masses being multiples of that unit. We have no evidence that it is possible for the ratio of two masses to be an incommensurable quantity, for the incommensurable quantities in geometry are supposed to be traced out in a continuous medium. If matter is atomic, and therefore discontinuous, it is unfitted for the construction of perfect geometrical models, but in other respects it may fulfil its functions.

But even if we adopt a theory which makes the equality of the mass of different atoms a result depending on the nature of mass rather than on any quantitative adjustment, the correspondence of the periods of vibration of actual molecules is a fact of a different order.

We know that radiations exist having periods of vibration of every value between those corresponding to the limits of the visible spectrum, and probably far beyond these limits on both sides. The most powerful spectroscopes can detect no gap or discontinuity in the spectrum of the light emitted by incandescent lime.

The period of vibration of a luminous particle is therefore a quantity which in itself is capable of assuming any one of a series of values, which, if not mathematically continuous, is such that consecutive observed values differ from each other by less than the ten thousandth part of either. There is, therefore, nothing in the nature of time itself to prevent the period of vibration of a molecule from assuming any one of many thousand different observable

values. That which determines the period of any particular kind of vibration is the relation which subsists between the corresponding type of displacement and the force of restitution thereby called into play, a relation involving constants of space and time as well as of mass.

It is the equality of these space- and time-constants for all molecules of the same kind which we have next to consider. We have seen that the very different circumstances in which different molecules of the same kind have been placed have not, even in the course of many ages, produced any appreciable difference in the values of these constants. If, then, the various processes of nature to which these molecules have been subjected since the world began have not been able in all that time to produce any appreciable difference between the constants of one molecule and those of another, we are forced to conclude that it is not to the operation of any of these processes that the uniformity of the constants is due.

The formation of the molecule is therefore an event not belonging to that order of nature under which we live. It is an operation of a kind which is not, so far as we are aware, going on on earth or in the sun or the stars, either now or since these bodies began to be formed. It must be referred to the epoch, not of the formation of the earth or of the solar system, but of the establishment of the existing order of nature, and till not only these worlds and systems, but the very order of nature itself is dissolved, we have no reason to expect the occurrence of any operation of a similar kind.

In the present state of science, therefore, we have strong reasons for believing that in a molecule, or if not in a molecule, in one of its component atoms, we have something which has existed either from eternity or at least from times anterior to the existing order of nature. But besides this atom, there are immense numbers of other atoms of the same kind, and the constants of each of these atoms are incapable of adjustment by any process now in action. Each is physically independent of all the others.

Whether or not the conception of a multitude of beings existing from all eternity is in itself self-contradictory, the conception becomes palpably absurd when we attribute a relation of quantitative equality to all these beings. We are then forced to look beyond them to some common cause or common origin to explain why this singular relation of equality exists, rather than any one of the infinite number of possible relations of inequality.

Science is incompetent to reason upon the creation of matter itself out of nothing. We have reached the utmost limit of our thinking faculties when we have admitted that, because matter cannot be eternal and self-existent, it must have been created. It is only when we contemplate not matter in itself, but the form in which it actually exists, that our mind finds something on which it can lay hold.

That matter, as such, should have certain fundamental properties, that it should have a continuous existence in space and time, that all action should be between two portions of matter, and so on, are truths which may, for aught we know, be of the kind which metaphysicians call necessary. We may use our knowledge of such truths for purposes of deduction, but we have no data for speculating on their origin.

But the equality of the constants of the molecules is a fact of a very different order. It arises from a particular distribution of matter, a *collocation*, to use the expression of Dr Chalmers, of things which we have no difficulty in imagining to have been arranged otherwise. But many of the ordinary instances of collocation are adjustments of constants, which are not only arbitrary in their own nature, but in which variations actually occur; and when it is pointed out that these adjustments are beneficial to living beings, and are therefore instances of benevolent design, it is replied that those variations which are not conducive to the growth and multiplication of living beings tend to their destruction, and to the removal thereby of the evidence of any adjustment not beneficial.

The constitution of an atom, however, is such as to render it, so far as we can judge, independent of all the dangers arising from the struggle for existence. Plausible reasons may, no doubt, be assigned for believing that if the constants had varied from atom to atom through any sensible range, the bodies formed by aggregates of such atoms would not have been so well fitted for the construction of the world as the bodies which actually exist. But as we have no experience of bodies formed of such variable atoms this must remain a bare conjecture.

Atoms have been compared by Sir J. Herschel to manufactured articles, on account of their uniformity. The uniformity of manufactured articles may be traced to very different motives on the part of the manufacturer. In certain cases it is found to be less expensive as regards trouble, as well as cost, to make a great many objects exactly alike than to adapt each to its special requirements. Thus, shoes for soldiers are made in large numbers without any designed adaptation to the feet of particular men. In another class of cases the uniformity is intentional, and is designed to make the manufactured article more valuable. Thus, Whitworth's bolts are made in a certain number of sizes, so that if one bolt is lost, another may be got at once, and accurately fitted to its place. The identity of the arrangement of the words in the different copies of a document or book is a matter of great practical importance, and it is more perfectly secured by the process of printing than by that of manuscript copying.

In a third class not a part only but the whole of the value of the object arises from its exact conformity to a given standard. Weights and measures belong to this class, and the existence of many well-adjusted material standards of weight and measure in any country furnishes evidence of the existence of a system of law regulating the transactions of the inhabitants, and enjoining in all professed measures a conformity to the national standard.

There are thus three kinds of usefulness in manufactured articles—cheapness, serviceableness, and quantitative accuracy. Which of these was present to the mind of Sir J. Herschel we cannot now positively affirm, but it was at least as likely to have been the last as the first, though it seems more probable that he meant to assert that a number of exactly similar things cannot be each of them eternal and self-existent, and must therefore have been made, and that he used the phrase "manufactured article" to suggest the idea of their being made in great numbers.

(J. C. M.)

ATOOL, one of the larger Sandwich Islands, in the South Pacific Ocean. Towards the N.E. and N.W. the country is rugged and broken, but to the southward it is more level. The hills rise from the sea with a gentle acclivity, and, at a little distance back, are covered with wood; the central peaks attain an elevation of 7000 feet.

The chief ports are Waimea and Hanalei. The island was one of the stations chosen for the observation of the transit of Venus in 1874. It is nearly 40 miles in length, and contains about 10,000 inhabitants. Long. 159° 40' W., lat. 21° 57' N.

ATRATO, a river of Colombia, South America, which,

after a course of 250 miles, almost due N., for the most part through a low and swampy region, falls into the Gulf of Uraba or Darien. The gold and platinum mines of Choco were on some of its affluents, and its sands are still auriferous. The river has attracted considerable attention in connection with schemes for the construction of a ship-canal across the isthmus. It is navigable for small vessels for about 140 miles.

**ATREK** or **ARRUCK**, a river which rises in the mountains of Khorasan, and flows W. along the borders of Persia and the Russian possessions, till it falls in the south-eastern corner of the Caspian, a short distance to the N. of Ashurada.

**ATREUS**, in *Greek Legend*, a son of Pelops, had, with his brother Thyestes, settled in Mycenæ, where he succeeded Eurystheus in the sovereignty, in which he was secured by the possession of a lamb or ram with a golden fleece. His wife Aërope, a daughter of Minos, bribed by Thyestes, assisted the latter to carry off the ram. But Zeus, in the interest of Atreus, wrought a miracle, causing the sun which before had risen in the west to rise in the east. Thyestes was driven from Mycenæ, but returned to his brother begging to be forgiven. Atreus, appearing to welcome him, invited him to a banquet to eat of his own son, whom he had slain. From this crime followed the ills which befel Agamemnon, the son of Atreus (*Æschylus, Agam.* 1583, *fol.*)

**ATRI** or **ATRIA**, the ancient *Hadria*, a town of Naples, in the province of Abruzzo Ulteriore I., situated on a steep mountain 5 miles from the Adriatic, and 18 miles S.E. of Teramo. It is the see of a bishop, and has a cathedral, a parish church, and several convents and hospitals. It contains 9877 inhabitants. Remains of the ancient city have been discovered to the S. of the present site, consisting of the ruins of a theatre and baths, with pavements, and vases of Greek manufacture. It was a very flourishing commercial port at an early period, but had declined into a small town in the time of Strabo. Its modern revival has been furthered by the excavation of new canals.

**ATRIUM**, the principal apartment in a Roman house, was entered through the *œtium* or *janua*, which opened off the *vestibulum*, a clear space between the middle of the house and the street, formed by the projection of the two sides. It was generally quadrangular in shape, and was roofed all over, with the exception of a square opening, called *compluvium*, towards which the roofs sloped, and by which the rain-water was conducted down to a basin (*impluvium*) fixed in the floor. The opening in the roof seems sometimes to have been called *impluvium* (Terence, *Eun.*, iii. 5; *Phorm.*, iv. 4). In the early periods of Roman civilisation, the atrium was the common public apartment, and was used for the reception of visitors and clients, and for ordinary domestic purposes, as cooking and dining. In it were placed the ancestral pictures, the marriage-couch, the *focus*, or hearth, and generally a small altar. Here, too, were kept the looms at which the mistress of the house sat and span with her maid-servants. At a somewhat later period, and among the wealthy, separate apartments were built for kitchens and dining-rooms, and the atrium was kept as a general reception room for clients and visitors. It appears sometimes to have been called *cavadium*, but the relation of these two is somewhat obscure. According to some authorities, the *cavadium* was simply the open space formed when the impluvium was surrounded with pillars to support the roof; according to others, the *cavadium* was really the principal room, to which the atrium served as an antechamber.

**ATRIUM**, in *Ecclesiastical Antiquities*, denotes an open place or court before a church. It consisted of a large area or square plat of ground, surrounded with a portico or

cloister, situated between the porch or vestibule and the body of the church. In the centre was placed a fountain, wherein the worshippers washed their hands before entering church. In the atrium those who were not suffered to advance farther, and more particularly the first class of penitents, stood to solicit the prayers of the faithful as they went into the church. It was also used as a burying-ground, at first only for distinguished persons, but afterwards for all believers.

**ATROPHY** (a priv., *τροφή*, nourishment), a term in medicine used to describe a state of wasting due to some interference with the function of healthy nutrition. In the living organism there are ever at work changes involving the waste of its component tissues, which render necessary, in order to the preservation of life, the supply and proper assimilation of nutritive material. It is also essential for the maintenance of health that a due relation exist between these processes of waste and repair, so that the one may not be in excess of the other. When the appropriation of nutriment exceeds the waste, hypertrophy or increase in bulk of the tissues takes place. (See *HYPER-TROPHY*.) When, on the other hand, the supply of nutritive matter is suspended or diminished, or when the power of assimilation is impaired, atrophy or wasting is the result. Thus the whole body becomes atrophied in many diseases; and in old age every part of the frame, with the single exception of the heart, undergoes atrophic change. Atrophy may, however, affect single organs or parts of the body, irrespective of the general state of nutrition, and this may be brought about in a variety of ways. One of the most frequently observed of such instances is atrophy from disease, or cessation of function. Thus, when a limb is deprived of the natural power of motion, either by paralysis or by painful joint disease, the condition of exercise essential to its nutrition being no longer fulfilled, atrophy of all its textures sooner or later takes place. The brain in imbeciles is frequently observed to be shrivelled, and in many cases of blindness there is atrophy of the optic nerve and optic tract. This form of atrophy is likewise well exemplified in the case of those organs and structures of the body which subserve important ends during foetal life, but which, ceasing to be necessary after birth, undergo a sort of natural atrophy, such as the thymus gland, and certain vessels specially concerned in the foetal circulation. The uterus after parturition undergoes a certain amount of atrophy, and the ovaries, after the child-bearing period, become shrunken. Atrophy of a part may also be caused by interruption to its normal blood supply, as in the case of the ligature or obstruction of an artery. Again, long standing disease, by affecting the nutrition of an organ and by inducing the deposit of morbid products, may result in atrophy, as frequently happens in affections of the liver and kidneys. Parts that are subjected to continuous pressure are liable to become atrophied, as is sometimes seen in internal organs which have been pressed upon by tumours or other morbid growths, and is well illustrated in the case of the feet of Chinese ladies, which are prevented from growing by persistent compression exercised from birth. Atrophy may manifest itself simply by loss of substance; but, on the other hand, it is often found to co-exist with degenerative changes in the textures affected and the formation of adventitious growth, so that the part may not be reduced in bulk although atrophied as regards its proper structure. Thus, in the case of the heart, when affected with fatty degeneration, there is atrophy of the proper muscular texture, which, however, being largely replaced by fatty matter, the organ may undergo no diminution in volume, but may, on the contrary, be increased in size. Atrophy is usually a gradual and slow process, but sometimes it proceeds rapidly. In the disease known by the

name of *acute yellow atrophy of the liver*, that organ undergoes such rapidly destructive change as results in its shrinking to half, or one-third, of its normal size in the course of a few days.

The term *progressive muscular atrophy* (synonyms, *wasting or creeping palsy*) is applied to an affection of the muscular system, which is characterised by the atrophy and subsequent paralysis of certain muscles, or groups of muscles, and is associated with morbid changes in the anterior roots of the nerves of the spinal cord. This disease begins insidiously, and is often first observed to affect the muscles of one hand, generally the right. The attention of the sufferer is first attracted by the power of the hand becoming weakened, and then there is found to be a wasting of certain of its muscles, particularly those of the ball of the thumb. Gradually other muscles in the arms and legs become affected in a similar manner, their atrophy being attended with a corresponding diminution in power. Although sometimes arrested, this disease tends to progress, involving additional muscles, until in course of time the greater part of the muscular system is implicated, and a fatal result ensues. (J. O. A.)

ATROPOS (a priv., and *σπέρω*, to turn), the eldest of the three Moirai, Parca, or Fates. Her name, The Unalterable, indicates the part generally played by her, viz., that of rendering the decisions of her sisters irreversible or immutable. This is the function ascribed to her by Plato (*Rep.*, x. 620), who also assigns to her supremacy over future events (617). Ancient authorities, however, are not unanimous in their distribution of the parts of the three sisters. Atropos is most frequently represented with scales, a sun-dial, or a cutting instrument, the "abhorred shears," with which she alits the thin-spun thread of life that has been placed on the spindle by Clotho and drawn off by Lachesis. See PAROS.

ATTACHMENT, in *English Law*, is a process from a court of record, awarded by the justices at their discretion, on a bare suggestion, or on their own knowledge, and is properly grantable in cases of contempt. It differs from arrest, in that he who arrests a man carries him to a person of higher power to be forthwith disposed of; but he that attaches keeps the party attached, and presents him in court at the day assigned, as appears by the words of the writ. Another difference is, that arrest is only upon the body of a man, whereas an attachment is often upon his goods. It is distinguished from distress in not extending to lands, as the latter does; nor does a distress touch the body, as an attachment does. Every court of record has power to fine and imprison for contempt of its authority. Attachment being merely a process to bring the defendant before the court, is not necessary in cases of contempt in the presence of the court itself. Attachment will be granted against peers and members of Parliament, only for such gross contempts as rescues, disobedience to the Queen's writs, and the like. Attachment will not lie against a corporation. The County Courts in this respect are regulated by the 9 and 10 Vict. c. 95, § 113, and the 12 and 13 Vict. c. 101, § 2. They can only punish for contempts committed in presence of the court. (See CONTEMPT OF COURT.) Attachments are granted on a rule in the first instance to show cause, which must be personally served before it can be made absolute, except for non-payment of costs on a master's allocatur, and against a sheriff for not obeying a rule to return a writ or to bring in the body. The offender is then arrested, and when committed will be compelled to answer interrogatories, exhibited against him by the party at whose instance the proceedings have been had; and the examination when taken is referred to the master, who reports thereon, and on the contempt being reported, the court gives judgment according to its dis-

cretion, in the same manner as upon a conviction for a misdemeanour at common law. Sir W. Blackstone observes that "this method of making the defendant answer upon oath to a criminal charge is not agreeable to the genius of the common law in any other instance," and it may be added that the elasticity of the legal definitions of contempt of court, especially with respect to comments on judicial proceedings, is the subject of much complaint.

ATTACHMENT OUT OF CHANCERY enforced answers and obedience to decrees and orders of that court, now merged in the High Court of Justice under the Judicature Act, 1873, and was made out without order upon an affidavit of the due service of the process, &c., with whose requirements compliance was sought. A corporation, however, is proceeded against by distringas and not by attachment. It was formerly competent to the plaintiff to compel the appearance of a defendant in Chancery by attachment, but the usual course was to enter appearance for him in case of default. By the proposed rules under the Judicature Act, 1873, a writ of attachment is to have the same force and effect as the old attachment out of Chancery. It is one of the modes of execution allowed for the recovery of property other than land or money.

ATTACHMENT OF THE FOREST is the proceeding in the Courts of Attachments, Woodmote, or Forty Days' Courts. These courts have now fallen into absolute desuetude. They were held before the verderers of the royal forests in different parts of the kingdom once in every forty days, for the purpose of inquiring into all offences against "vert and venison." The attachment is by the bodies of the offenders, if taken in the very act of killing venison, or stealing wood, or preparing so to do, or by fresh and immediate pursuit after the act is done; else they must be attached by their goods. These attachments were received by the verderers and enrolled, and certified under their seals to the Court of Justice seat, or Swainmote, which formed the two superior of the forest courts.

ATTACHMENT, FOREIGN, is an important custom prevailing in the city of London, whereby a creditor may attach money owing to his debtor, or property belonging to him in the possession of third parties. The person holding the property or owing the money must be within the city at the time of being served with the process, but all persons are entitled to the benefit of the custom. The plaintiff having commenced his action, and made a satisfactory affidavit of his debt, is entitled to issue attachment, which thereupon affects all the money or property of the defendant in the hands of the third party, who in these proceedings is called the *garnishee*. The garnishee, of course, has as against the attachment all the defences which would be available to him against the defendant, his alleged creditor. The garnishee may plead payment under the attachment, if there has been no fraud or collusion, in bar to an action by the defendant for his debt or property. The court to which this process belongs is the Mayor's Court of London, the procedure in which is regulated by 20 and 21 Vict. c. 157. This custom, and all proceedings relating thereto, are expressly exempted from the operation of the Debtor's Act, 1869. Similar customs exist in Bristol and a few other towns in England, and also in Scotland. See ARREST and ARRESTMENT.

ATTACHMENT OF DEBTS.—It was suggested by the common law commissioners in 1853 that a remedy analogous to that of Foreign Attachment might be made available to creditors, after judgment, against debts due to their debtors. Accordingly, the Common Law Procedure Act, 1854, enacted that any creditor, having obtained judgment in the superior courts, should have an order that

the judgment debtor might be examined as to any debts due and owing to him before a master of the court. On affidavit that the judgment was still unsatisfied, and that any other person within the jurisdiction was indebted to the judgment debtor, the judge was empowered to attach all debts due from such third person (called the *garnishee*) to the judgment debtor, to answer the judgment debt. This order binds the debts in the hands of the garnishee, and if he does not dispute his liability execution issues against him at once. If he disputes his liability the question must be tried. Payment by the garnishee or execution against him is a complete discharge as against the judgment debtor. These provisions were, by an order in Council of 18th Nov. 1867, extended to the County Courts. (By 33 and 34 Vict. c. 30, it is enacted that no order for the attachment of the wages of any servant, labourer, or workman shall be made by the judge of any court of record or inferior court.) The proposed rules and regulations under the Judicature Act, 1873, retain the process for attachment of debts as established by the Procedure Act of 1854.

ATTAINER, in the *Law of England*, was the immediate and inseparable consequence from the common law upon the sentence of death. When it was clear beyond all dispute that the criminal was no longer fit to live, he was called *attaint*, *atinctus*, stained or blackened, and could not, before the 6 and 7 Vict. c. 85, § 1, be a witness in any court. This attainder took place after judgment of death, or upon such circumstances as were equivalent to judgment of death, such as judgment of outlawry on a capital crime, pronounced for absconding from justice. Conviction without judgment was not followed by attainder. The consequences of attainder were—1st, Forfeiture; 2d, Corruption of blood. On attainder for treason, the criminal forfeited to the Crown his lands, rights of entry on lands, and any interest he might have in lands for his own life or a term of years. For murder, the offender forfeited to the Crown the profit of his freeholds during life, and in the case of lands held in fee-simple, the lands themselves for a year and a day; subject to this, the lands escheated to the lord of the fee. These forfeitures related back to the time of the offence committed. Forfeitures of goods and chattels ensued not only on attainder, but on conviction for a felony of any kind, or on flight from justice, and had no relation backwards to the time of the offence committed. By *corruption of blood*, "both upwards and downwards," the attainted person could neither inherit nor transmit lands. The lands escheated to the lord of the fee, subject to the Crown's right of forfeiture. The doctrine of attainder has, however, ceased to be of much importance. By the 33 and 34 Vict. c. 23, it is enacted that henceforth no confession, verdict, inquest, conviction, or judgment of or for any treason or felony, or *felo de se*, shall cause any attainder or corruption of blood, or any forfeiture or escheat. Sentence of death, penal servitude, or imprisonment with hard labour for more than twelve months, after conviction for treason or felony, disqualifies from holding or retaining a seat in Parliament, public offices under the Crown or otherwise, right to vote at elections, &c., and such disability is to remain until the punishment has been suffered or a pardon obtained. Provision is made for the due administration of convicts' estates, in the interests of themselves and their families. Forfeiture consequent on outlawry is exempted from the provisions of the Act.

*Bills of Attainder* in Parliament ordinarily commence in the House of Lords; the proceedings are the same as on other bills, but the parties affected by them may appear by counsel and witnesses in both Houses. In the case of an impeachment, the House of Commons is prosecutor and the House of Lords judge; but proceedings by Bill of

Attainder are *legislative* in form, and the consent of Crown, Lords, and Commons is therefore necessary.

ATTALIA, an ancient city of Pamphylia, which derived its name from Attalus II, king of Pergamum. It seems to have been a place of considerable importance, and is most probably to be identified with the modern Adalia, Antalia, or Sataliah, as it is variously called. See SATALIAH.

ATTAR, or OTTO, of ROSES, a well-known perfume of great strength, is an essential oil of roses, prepared chiefly in Hindustan and Persia. See OILS and PERFUMERY.

ATTENTION, in *Psychology*, may be defined as the concentration of consciousness, or the direction of mental energy upon a definite object or objects. By means of it we either bring within the circle of our conscious life perceptions and ideas which would not otherwise have risen from their obscurity, or render clearer and more distinct some of those already under notice. Its mode of operation and the effects produced by it may be compared with the concentration of visual activity on some definite part of the field of vision, and the clearer perception of the limited portion which is thereby attained. In both cases the result is brought about, not by effecting any change in the perceptions themselves, but simply by isolating them, and considering them to the exclusion of all other objects. Since all consciousness involves discrimination, i.e., isolation of one object from others, it involves attention, which might therefore be defined as the necessary condition of consciousness. Such a definition is, however, too general, and throws no light upon the nature of the process whereby our mental energy is strengthened in particular cases. This increase of force, when consciousness is directed to any one object to the exclusion of others, is partly to be explained by reference to the general law that, as the amount of intellectual energy at our disposal is limited, the greater the number of objects over which it is spread, the less will each receive, *pluribus intentus, minor est ad singula sensus*; and conversely, the greater the concentration, the fewer must be the objects attended to. In addition to this general law of limitation, there are special circumstances which determine the amount of consciousness we shall bestow on any object. In the first place, there are certain mechanical influences only partly subject to the will, such as the force or vividness of the impression, the interest attaching to an object, the trains of associated ideas excited, or the emotions roused by its contemplation. There is, secondly, an exercise of volition employed in fixing the mind upon some definite object; this is a purely voluntary act, which can be strengthened by habit, is variable in different individuals, and to which, as being its highest stage, the name Attention is sometimes restricted. The general law of the limitation of conscious activity, pointed out above, throws considerable light on the nature of abstraction and its relation to Attention. It is clear that concentration of consciousness upon any one attribute or attributes of an object involves withdrawal of consciousness from all other attributes. This withdrawal is, logically and etymologically, Abstraction, which is thus the negative side of Attention, or, as Hamilton expresses it, the two processes form the negative and positive poles of the same mental act.

ATTERBOM, PER DANIEL AMADEUS, a Swedish poet, was born in Ostergöthland in 1790, studied in the University of Upsala from 1805 to 1815, became Professor of Philosophy there in 1828, and died in 1855. He was the leader in the great romantic movement which revolutionised Swedish literature. In 1807, when in his 17th year, he founded at Upsala an artistic society, called the Aurora League, the members of which included Palmblad, Elgström, Hedborn, and other youths, whose names were destined to



take a foremost rank in the belles-lettres of their generation. Their first newspaper, *Polyæm*, was a crude effort, soon abandoned, but in 1810 there began to appear a journal, *Fosforus*, edited by Atterbom, which lasted for a considerable time, and finds a place in classic Swedish literature. It consisted entirely of poetry and æsthetic-polemical essays; it introduced the study of the newly-arisen Romantic school of Germany, and formed a vehicle for the early works, not of Atterbom only, but of Hammarsköld, Dahlgren, Palmblad, and other eminent poets. Among Atterbom's independent works the most celebrated is *Lycksalighetens ö* (*The Fortunate Island*), a romantic drama of extraordinary beauty, published in 1823. Before this he had published a cycle of lyrics, *The Flowers*, of a mystical character, somewhat in the manner of Novalis. Of a great drama, *Fogel blå* (*The Blue Bird*), only a fragment is preserved, but what exists is among the most exquisite of his writings. As a purely lyrical poet he has not been excelled in Sweden, but his popularity has been endangered, partly by his weakness for allegory and symbolism, partly by his consistent adoption of the mannerisms of Tieck and Novalis. His renown during his lifetime was unbounded.

ATTERBURY, FRANCIS, a man who holds a conspicuous place in the political, ecclesiastical, and literary history of England, was born in the year 1662, at Middleton in Buckinghamshire, a parish of which his father was rector. Francis was educated at Westminster School, and carried thence to Christ Church a stock of learning which, though really scanty, he through life exhibited with such judicious ostentation that superficial observers believed his attainments to be immense. At Oxford, his parts, his taste, and his bold, contemptuous, and imperious spirit soon made him conspicuous. Here he published, at twenty, his first work, a translation of the noble poem of *Abesalom and Ahithophel* into Latin verse. Neither the style nor the versification of the young scholar was that of the Augustan age. In English composition he succeeded much better. In 1687 he distinguished himself among many able men who wrote in defence of the Church of England, then persecuted by James II., and calumniated by apostates who had for lucre quitted her communion. Among these apostates none was more active or malignant than Obediah Walker, who was master of University College, and who had set up there, under the royal patronage, a press for printing tracts against the established religion. In one of these tracts, written apparently by Walker himself, many aspersions were thrown on Martin Luther. Atterbury undertook to defend the great Saxon Reformer, and performed that task in a manner singularly characteristic. Whoever examines his reply to Walker will be struck by the contrast between the feebleness of those parts which are argumentative and defensive, and the vigour of those parts which are rhetorical and aggressive. The Papists were so much galled by the sarcasms and invectives of the young polemic, that they raised a cry of treason, and accused him of having, by implication, called King James a Judas.

After the Revolution, Atterbury, though bred in the doctrines of non-resistance and passive obedience, readily swore fealty to the new Government. In no long time he took holy orders. He occasionally preached in London with an eloquence which raised his reputation, and soon had the honour of being appointed one of the royal chaplains. But he ordinarily resided at Oxford, where he took an active part in academical business, directed the classical studies of the undergraduates of his college, and was the chief adviser and assistant of Dean Aldrich, a divine now chiefly remembered by his catches, but renowned among his contemporaries as a scholar, a Tory, and a High-

Churchman. It was the practice, not a very judicious practice, of Aldrich, to employ the most promising youths of his college in editing Greek and Latin books. Among the studious and well-disposed lads who were, unfortunately for themselves, induced to become teachers of philology when they should have been content to be learners, was Charles Boyle, son of the earl of Orrery, and nephew of Robert Boyle, the great experimental philosopher. The task assigned to Charles Boyle was to prepare a new edition of one of the most worthless books in existence. It was a fashion among those Greeks and Romans who cultivated rhetoric as an art, to compose epistles and harangues in the names of eminent men. Some of these counterfeits are fabricated with such exquisite taste and skill, that it is the highest achievement of criticism to distinguish them from originals. Others are so feebly and rudely executed, that they can hardly impose on an intelligent schoolboy. The best specimen which has come down to us is perhaps the *Oration for Marcellus*, such an imitation of Tully's eloquence as Tully would himself have read with wonder and delight. The worst specimen is perhaps a collection of letters purporting to have been written by that Phalaris who governed Agrigentum more than 500 years before the Christian era. The evidence, both internal and external, against the genuineness of these letters is overwhelming. When, in the 15th century, they emerged, in company with much that was far more valuable, from their obscurity, they were pronounced spurious by Politian, the greatest scholar of Italy, and by Erasmus, the greatest scholar on our side of the Alps. In truth, it would be as easy to persuade an educated Englishman, that one of Johnson's *Ramblers* was the work of William Wallace, as to persuade a man like Erasmus, that a pedantic exercise, composed in the trim and artificial Attic of the time of Julian, was a despatch written by a crafty and ferocious Dorian, who roasted people alive many years before there existed a volume of prose in the Greek language. But though Christ Church could boast of many good Latinists, of many good English writers, and of a greater number of clever and fashionable men of the world than belonged to any other academic body, there was not then in the college a single man capable of distinguishing between the infancy and the dotage of Greek literature. So superficial, indeed, was the learning of the rulers of this celebrated society, that they were charmed by an essay which Sir William Temple published in praise of the ancient writers. It now seems strange, that even the eminent public services, the deserved popularity, and the graceful style of Temple, should have saved so silly a performance from universal contempt. Of the books which he most vehemently eulogised, his eulogies proved that he knew nothing. In fact, he could not read a line of the language in which they were written. Among many other foolish things, he said that the letters of Phalaris were the oldest letters and also the best in the world. Whatever Temple wrote attracted notice. People who had never heard of the *Epistles of Phalaris* began to inquire about them. Aldrich, who knew very little Greek, took the word of Temple who knew none, and desired Boyle to prepare a new edition of these admirable compositions which, having long slept in obscurity, had become on a sudden objects of general interest.

The edition was prepared with the help of Atterbury, who was Boyle's tutor, and of some other members of the college. It was an edition such as might be expected from people who would stoop to edit such a book. The notes were worthy of the text; the Latin version worthy of the Greek original. The volume would have been forgotten in a month, had not a misunderstanding about a manuscript arisen between the young editor and the

greatest scholar that had appeared in Europe since the revival of letters, Richard Bentley. The manuscript was in Bentley's keeping. Boyle wished it to be collated. A mischief-making bookseller informed him that Bentley had refused to lend it, which was false, and also that Bentley had spoken contemptuously of the letters attributed to Phalaris, and of the critics who were taken in by such counterfeits, which was perfectly true. Boyle, much provoked, paid, in his preface, a bitterly ironical compliment to Bentley's courtesy. Bentley revenged himself by a short dissertation, in which he proved that the epistles were spurious, and the new edition of them worthless; but he treated Boyle personally with civility as a young gentleman of great hopes, whose love of learning was highly commendable, and who deserved to have had better instructors.

Few things in literary history are more extraordinary than the storm which this little dissertation raised. Bentley had treated Boyle with forbearance; but he had treated Christ Church with contempt; and the Christ Churchmen, wherever dispersed, were as much attached to their college as a Scotchman to his country, or a Jesuit to his order. Their influence was great. They were dominant at Oxford, powerful in the Inns of Court and in the College of Physicians, conspicuous in Parliament and in the literary and fashionable circles of London. Their unanimous cry was that the honour of the college must be vindicated, that the insolent Cambridge pedant must be put down. Poor Boyle was unequal to the task, and disinclined to it. It was, therefore, assigned to his tutor Atterbury.

The answer to Bentley, which bears the name of Boyle, but which was, in truth, no more the work of Boyle than the letters to which the controversy related were the work of Phalaris, is now read only by the curious, and will in all probability never be reprinted again. But it had its day of noisy popularity. It was to be found not only in the studies of men of letters, but on the tables of the most brilliant drawing-rooms of Soho Square and Covent Garden. Even the beaux and coquettes of that age, the Wildairs and the Lady Lurewells, the Mirabella, and the Millamants, congratulated each other on the way in which the gay young gentleman, whose erudition sat so easily upon him, and who wrote with so much pleasantry and good breeding about the Attic dialect and the anapestic measure, Sicilian talents and Thericlean cups, had bantered the queer prig of a doctor. Nor was the applause of the multitude undeserved. The book is, indeed, Atterbury's masterpiece, and gives a higher notion of his powers than any of those works to which he put his name. That he was altogether in the wrong on the main question, and on all the collateral questions springing out of it, that his knowledge of the language, the literature, and the history of Greece, was not equal to what many freshmen now bring up every year to Cambridge and Oxford, and that some of his blunders seem rather to deserve a flogging than a refutation, is true; and therefore it is that his performance is, in the highest degree, interesting and valuable to a judicious reader. It is good by reason of its exceeding badness. It is the most extraordinary instance that exists of the art of making much show with little substance. There is no difficulty, says the steward of Molière's miser, in giving a fine dinner with plenty of money: the really great cook is he who can set out a banquet with no money at all. That Bentley should have written excellently on ancient chronology and geography, on the development of the Greek language, and the origin of the Greek drama, is not strange. But that Atterbury should, during some years, have been thought to have treated these subjects much better than Bentley, is strange indeed. It is true that the champion of Christ Church

had all the help which the most celebrated members of that society could give him. Smalridge contributed some very good wit; Friend and others some very bad archaeology and philology. But the greater part of the volume was entirely Atterbury's: what was not his own was revised and retouched by him; and the whole bears the mark of his mind—a mind inexhaustibly rich in all the resources of controversy, and familiar with all the artifices which make falsehood look like truth, and ignorance like knowledge. He had little gold; but he beat that little out to the very thinnest leaf, and spread it over so vast a surface, that to those who judged by a glance, and who did not resort to balances and tests, the glittering heap of worthless matter which he produced seemed to be an inestimable treasure of massy bullion. Such arguments as he had he placed in the clearest light. Where he had no arguments, he resorted to personalities, sometimes serious, generally ludicrous, always clever and cutting. But, whether he was grave or merry, whether he reasoned or sneered, his style was always pure, polished, and easy.

Party spirit then ran high; yet, though Bentley ranked among Whigs, and Christ Church was a stronghold of Toryism, Whigs joined with Tories in applauding Atterbury's volume. Garth insulted Bentley, and extolled Boyle in lines which are now never quoted except to be laughed at. Swift, in his *Battle of the Books*, introduced with much pleasantry Boyle, clad in armour, the gift of all the gods, and directed by Apollo in the form of a human friend, for whose name a blank is left which may easily be filled up. The youth, so accoutred and so assisted, gains an easy victory over his uncourteous and boastful antagonist. Bentley, meanwhile, was supported by the consciousness of an immeasurable superiority, and encouraged by the voices of the few who were really competent to judge the combat. "No man," he said, justly and nobly, "was ever written down but by himself." He spent two years in preparing a reply, which will never cease to be read and prized while the literature of ancient Greece is studied in any part of the world. This reply proved not only that the letters ascribed to Phalaris were spurious, but that Atterbury, with all his wit, his eloquence, his skill in controversial fence, was the most audacious pretender that ever wrote about what he did not understand. But to Atterbury this exposure was matter of indifference. He was now engaged in a dispute about matters far more important and exciting than the laws of Zaleucus and the laws of Charondas. The rage of religious factions was extreme. High Church and Low Church divided the nation. The great majority of the clergy were on the High Church side; the majority of King William's bishops were inclined to latitudinarianism. A dispute arose between the two parties touching the extent of the powers of the Lower House of Convocation. Atterbury thrust himself eagerly into the front rank of the High Churchmen. Those who take a comprehensive and impartial view of his whole career will not be disposed to give him credit for religious zeal. But it was his nature to be vehement and pugnacious in the cause of every fraternity of which he was a member. He had defended the genuineness of a spurious book simply because Christ Church had put forth an edition of that book; he now stood up for the clergy against the civil power, simply because he was a clergyman, and for the priests against the episcopal order, simply because he was as yet only a priest. He asserted the pretensions of the class to which he belonged in several treatises written with much wit, ingenuity, audacity, and acrimony. In this, as in his first controversy, he was opposed to antagonists whose knowledge of the subject in dispute was far superior to his; but in this, as in his first controversy, he imposed on the multitude by bold assertion,

by sarcasm, by declamation, and, above all, by his peculiar knack of exhibiting a little erudition in such a manner as to make it look like a great deal. Having passed himself off on the world as a greater master of classical learning than Bentley, he now passed himself off as a greater master of ecclesiastical learning than Wake or Gibbon. By the great body of the clergy he was regarded as the ablest and most intrepid tribune that had ever defended their rights against the oligarchy of prelates. The Lower House of Convocation voted him thanks for his services; the University of Oxford created him a doctor of divinity; and soon after the accession of Anne, while the Tories still had the chief weight in the Government, he was promoted to the deanery of Carlisle.

Soon after he had obtained this preferment the Whig party rose to ascendancy in the state. From that party he could expect no favour. Six years elapsed before a change of fortune took place. At length, in the year 1710, the prosecution of Sacheverell produced a formidable explosion of High Church fanaticism. At such a moment Atterbury could not fail to be conspicuous. His inordinate zeal for the body to which he belonged, his turbulent and aspiring temper, his rare talents for agitation and for controversy, were again signally displayed. He bore a chief part in framing that artful and eloquent speech which the accused divine pronounced at the bar of the Lords, and which presents a singular contrast to the absurd and scurrilous sermon which had very unwisely been honoured with impeachment. During the troubled and anxious months which followed the trial, Atterbury was among the most active of those pamphleteers who inflamed the nation against the Whig ministry and the Whig Parliament. When the ministry had been changed and the Parliament dissolved, rewards were showered upon him. The Lower House of Convocation elected him prolocutor. The Queen appointed him dean of Christ Church on the death of his old friend and patron Aldrich. The college would have preferred a gentler ruler. Nevertheless, the new head was received with every mark of honour. A congratulatory oration in Latin was addressed to him in the magnificent vestibule of the hall; and he in reply professed the warmest attachment to the venerable house in which he had been educated, and paid many gracious compliments to those over whom he was to preside. But it was not in his nature to be a mild or an equitable governor. He had left the chapter of Carlisle distracted by quarrels. He found Christ Church at peace; but in three months his despotic and contentious temper did at Christ Church what it had done at Carlisle. He was succeeded in both his deaneries by the humane and accomplished Smalridge, who gently complained of the state in which both had been left. "Atterbury goes before, and sets everything on fire. I come after him with a bucket of water." It was said by Atterbury's enemies that he was made a bishop because he was so bad a dean. Under his administration Christ Church was in confusion, scandalous altercations took place, opprobrious words were exchanged; and there was reason to fear that the great Tory college would be ruined by the tyranny of the great Tory doctor. He was soon removed to the bishopric of Rochester, which was then always united with the deanery of Westminster. Still higher dignities seemed to be before him. For, though there were many able men on the Episcopal bench, there were none who equalled or approached him in parliamentary talents. Had his party continued in power it is not improbable that he would have been raised to the archbishopric of Canterbury. The more splendid his prospects the more reason he had to dread the accession of a family which was well known to be partial to the Whigs. There is every reason to believe that he was one of those

politicians who hoped that they might be able, during the life of Anne, to prepare matters in such a way that at her decease there might be little difficulty in setting aside the Act of Settlement and placing the Pretender on the throne. Her sudden death confounded the projects of these conspirators. Atterbury, who wanted no kind of courage, implored his confederates to proclaim James III., and offered to accompany the heralds in lawn sleeves. But he found even the bravest soldiers of his party irresolute, and exclaimed, not, it is said, without interjections which ill became the mouth of a father of the church, that the best of all causes and the most precious of all moments had been pusillanimously thrown away. He acquiesced in what he could not prevent, took the oaths to the House of Hanover, and at the coronation officiated with the outward show of zeal, and did his best to ingratiate himself with the royal family. But his servility was requited with cold contempt. No creature is so revengeful as a proud man who has humbled himself in vain. Atterbury became the most factious and pertinacious of all the opponents of the Government. In the House of Lords his oratory, lucid, pointed, lively, and set off with every grace of pronunciation and of gesture, extorted the attention and admiration even of a hostile majority. Some of the most remarkable protests which appear in the journals of the peers were drawn up by him; and, in some of the bitterest of those pamphlets which called on the English to stand up for their country against the aliens who had come from beyond the seas to oppress and plunder her, critics easily detected his style. When the rebellion of 1715 broke out, he refused to sign the paper in which the bishops of the province of Canterbury declared their attachment to the Protestant succession. He busied himself in electioneering, especially at Westminster, where as dean he possessed great influence; and was, indeed, strongly suspected of having once set on a riotous mob to prevent his Whig fellow-citizens from polling.

After having been long in indirect communication with the exiled family, he, in 1717, began to correspond directly with the Pretender. The first letter of the correspondence is extant. In that letter Atterbury boasts of having, during many years past, neglected no opportunity of serving the Jacobite cause. "My daily prayer," he says, "is that you may have success. May I live to see that day, and live no longer than I do what is in my power to forward it." It is to be remembered that he who wrote thus was a man bound to set to the church of which he was overseer an example of strict probity; that he had repeatedly sworn allegiance to the House of Brunswick; that he had assisted in placing the crown on the head of George I., and that he had abjured James III., "without equivocation or mental reservation, on the true faith of a Christian."

It is agreeable to turn from his public to his private life. His turbulent spirit, wearied with faction and treason, now and then required repose, and found it in domestic endearments, and in the society of the most illustrious of the living and of the dead. Of his wife little is known; but between him and his daughter there was an affection singularly close and tender. The gentleness of his manners when he was in the company of a few friends was such as seemed hardly credible to those who knew him only by his writings and speeches. The charm of his "softer hour" has been commemorated by one of those friends in imperishable verse. Though Atterbury's classical attainments were not great, his taste in English literature was excellent; and his admiration of genius was so strong that it overpowered even his political and religious antipathies. His fondness for Milton, the mortal enemy of the Stuarts and of the church, was such as to

many Tories seemed a crime. On the sad night on which Addison was laid in the chapel of Henry VII., the Westminster boys remarked that Atterbury read the funeral service with a peculiar tenderness and solemnity. The favourite companions, however, of the great Tory prelate were, as might have been expected, men whose politics had at least a tinge of Toryism. He lived on friendly terms with Swift, Arbuthnot, and Gay. With Prior he had a close intimacy, which some misunderstanding about public affairs at last dissolved. Pope found in Atterbury not only a warm admirer, but a most faithful, fearless, and judicious adviser. The poet was a frequent guest at the episcopal palace among the elms of Bromley, and entertained not the slightest suspicion that his host, now declining in years, confined to an easy chair by gout, and apparently devoted to literature, was deeply concerned in criminal and perilous designs against the Government.

The spirit of the Jacobites had been cowed by the events of 1715. It revived in 1721. The failure of the South Sea project, the panic in the money market, the downfall of great commercial houses, the distress from which no part of the kingdom was exempt, had produced general discontent. It seemed not improbable that at such a moment an insurrection might be successful. An insurrection was planned. The streets of London were to be barricaded; the Tower and the Bank were to be surprised; King George, his family, and his chief captains and councillors were to be arrested, and King James was to be proclaimed. The design became known to the duke of Orleans, regent of France, who was on terms of friendship with the house of Hanover. He put the English Government on its guard. Some of the chief malcontents were committed to prison; and among them was Atterbury. No bishop of the Church of England had been taken into custody since that memorable day when the applauses and prayers of all London had followed the seven bishops to the gate of the Tower. The Opposition entertained some hope that it might be possible to excite among the people an enthusiasm resembling that of their fathers, who rushed into the waters of the Thames to implore the blessing of Sancto. Pictures of the heroic confessor in his cell were exhibited at the shop windows. Verses in his praise were sung about the streets. The restraints by which he was prevented from communicating with his accomplices were represented as cruelties worthy of the dungeons of the Inquisition. Strong appeals were made to the priesthood. Would they tamely permit so gross an insult to be offered to their cloth? Would they suffer the ablest, the most eloquent member of their profession, the man who had so often stood up for their rights against the civil power, to be treated like the vilest of mankind? There was considerable excitement; but it was allayed by a temperate and artful letter to the clergy, the work, in all probability, of Bishop Gibson, who stood high in the favour of Walpole, and shortly after became minister for ecclesiastical affairs.

Atterbury remained in close confinement during some months. He had carried on his correspondence with the exiled family so cautiously that the circumstantial proofs of his guilt, though sufficient to produce entire moral conviction, were not sufficient to justify legal conviction. He could be reached only by a bill of pains and penalties. Such a bill the Whig party, then decidedly predominant in both Houses, was quite prepared to support. Many hot-headed members of that party were eager to follow the precedent which had been set in the case of Sir John Fenwick, and to pass an act for cutting off the bishop's head. Cadogan, who commanded the army, a brave soldier, but a headstrong politician, is said to have exclaimed with great vehemence, "Fling him to the lions in the Tower." But the wiser and more humane Walpole was

always unwilling to shed blood, and his influence prevailed. When Parliament met, the evidence against the bishop was laid before committees of both Houses. Those committees reported that his guilt was proved. In the Commons a resolution pronouncing him a traitor was carried by nearly two to one. A bill was then introduced which provided that he should be deprived of his spiritual dignities, that he should be banished for life, and that no British subject should hold any intercourse with him except by the royal permission. This bill passed the Commons with little difficulty; for the bishop, though invited to defend himself, chose to reserve his defence for the assembly of which he was a member. In the Lords the contest was sharp. The young duke of Wharton, distinguished by his parts, his dissoluteness, and his versatility, spoke for Atterbury with great effect; and Atterbury's own voice was heard for the last time by that unfriendly audience which had so often listened to him with mingled aversion and delight. He produced few witnesses, nor did those witnesses say much that could be of service to him. Among them was Pope. He was called to prove that, while he was an inmate of the palace at Bromley, the bishop's time was completely occupied by literary and domestic matters, and that no leisure was left for plotting. But Pope, who was quite unaccustomed to speak in public, lost his head, and, as he afterwards owned, though he had only ten words to say, made two or three blunders.

The bill finally passed the Lords by eighty-three votes to forty-three. The bishops, with a single exception, were in the majority. Their conduct drew on them a sharp taunt from Lord Bathurst, a warm friend of Atterbury and a zealous Tory. "The wild Indians," he said, "give no quarter, because they believe that they shall inherit the skill and prowess of every adversary whom they destroy. Perhaps the animosity of the right reverend prelates to their brother may be explained in the same way."

Atterbury took leave of those whom he loved with a dignity and tenderness worthy of a better man. Three fine lines of his favourite poet were often in his mouth—

"Some natural tears he dropped, but wiped them soon:  
The world was all before him, where to chuse  
His place of rest, and Providence his guide."

At parting he presented Pope with a Bible, and said, with a disingenuousness of which no man who had studied the Bible to much purpose would have been guilty, "If ever you learn that I have any dealings with the Pretender, I give you leave to say that my punishment is just." Pope at this time really believed the bishop to be an injured man. Arbuthnot seems to have been of the same opinion. Swift, a few months later, ridiculed with great bitterness, in the *Voyage to Laputa*, the evidence which had satisfied the two Houses of Parliament. Soon, however, the most partial friends of the banished prelate ceased to assert his innocence, and contented themselves with lamenting and excusing what they could not defend. After a short stay at Brussels he had taken up his abode at Paris, and had become the leading man among the Jacobite refugees who were assembled there. He was invited to Rome by the Pretender, who then held his mock court under the immediate protection of the Pope. But Atterbury felt that a bishop of the Church of England would be strangely out of place at the Vatican, and declined the invitation. During some months, however, he might flatter himself that he stood high in the good graces of James. The correspondence between the master and the servant was constant. Atterbury's merits were warmly acknowledged, his advice was respectfully received, and he was, as Bolingbroke had been before him, the prime minister of a king without a kingdom.

But the new favourite found, as Bolingbroke had found before him, that it was quite as hard to keep the shadow of power under a vagrant and mendicant prince as to keep the reality of power at Westminster. Though James had neither territories nor revenues, neither army nor navy, there was more faction and more intrigue among his courtiers than among those of his successful rival. Atterbury soon perceived that his counsels were disregarded, if not distrusted. His proud spirit was deeply wounded. He quitted Paris, fixed his residence at Montpellier, gave up politics, and devoted himself entirely to letters. In the sixth year of his exile he had so severe an illness that his daughter, herself in very delicate health, determined to run all risks that she might see him once more. Having obtained a licence from the English Government, she went by sea to Bordeaux, but landed there in such a state that she could travel only by boat or in a litter. Her father, in spite of his infirmities, set out from Montpellier to meet her; and she, with the impatience which is often the sign of approaching death, hastened towards him. Those who were about her in vain implored her to travel slowly. She said that every hour was precious, that she only wished to see her papa and to die. She met him at Toulouse, embraced him, received from his hand the sacred bread and wine, and thanked God that they had passed one day in each other's society before they parted for ever. She died that night.

It was some time before even the strong mind of Atterbury recovered from this cruel blow. As soon as he was himself again he became eager for action and conflict; for grief, which disposes gentle natures to retirement, to inaction, and to meditation, only makes restless spirits more restless. The Pretender, dull and bigoted as he was, had found out that he had not acted wisely in parting with one who, though a heretic, was, in abilities and accomplishments, the foremost man of the Jacobite party. The bishop was courted back, and was without much difficulty induced to return to Paris, and to become once more the phantom minister of a phantom monarchy. But his long and troubled life was drawing to a close. To the last, however, his intellect retained all its keenness and vigour. He learned, in the ninth year of his banishment, that he had been accused by Oldmixon, as dishonest and malignant a scribbler as any that has been saved from oblivion by the Dunciad, of having, in concert with other Christian Churchmen, garbled Clarendon's *History of the Rebellion*. The charge, as respected Atterbury, had not the slightest foundation; for he was not one of the editors of the *History*, and never saw it till it was printed. He published a short vindication of himself, which is a model in its kind, luminous, temperate, and dignified. A copy of this little work he sent to the Pretender, with a letter singularly eloquent and graceful. It was impossible, the old man said, that he should write anything on such a subject without being reminded of the resemblance between his own fate and that of Clarendon. They were the only two English subjects that had ever been banished from their country and debarred from all communication with their friends by Act of Parliament. But here the resemblance ended. One of the exiles had been so happy to bear a chief part in the restoration of the royal house. All that the other could now do was to die asserting the rights of that house to the last. A few weeks after this letter was written Atterbury died. He had just completed his seventieth year.

His body was brought to England, and laid, with great privacy, under the nave of Westminster Abbey. Only three mourners followed the coffin. No inscription marks the grave. That the epitaph with which Pope honoured the memory of his friend does not appear on the walls of

the great national cemetery is no subject of regret, for nothing worse was ever written by Colley Cibber.

Those who wish for more complete information about Atterbury may easily collect it from his sermons and his controversial writings, from the report of the parliamentary proceedings against him, which will be found in the *State Trials*; from the five volumes of his correspondence, edited by Mr Nichols, and from the first volume of the Stuart papers, edited by Mr Glover. A very interesting account of the bishop's political career will be found in Lord Stanhope's valuable *History of England*. (M.)

ATTICA, the most famous district of ancient Greece, is a triangular piece of ground projecting in a south-easterly direction into the *Ægean Sea*, the base line being formed by the continuous chain of Mounts Cithæron and Parnes, the apex by the promontory of Sunium. It is washed on



Sketch Map of Attica.

two sides by the sea, and this feature seems to have given rise to the name; for, notwithstanding the unusual letter-change, *Ἀττική* probably stands for *Ἀκτική*, since Strabo and other ancient writers inform us that the country originally bore both this name and that of *Ἀκτῆ*. The latter designation was frequently used by the Greeks to describe an extensive tract reaching into the sea, especially when, as in the case of Attica and the Argolic Acte, it was joined to the continent by a broad base. The coast is broken up into numerous small bights and harbours, which, however, are with few exceptions exposed to the south wind; the irregularity of the outline accounts for its great length in comparison of the superficial area of the country. The surface of Attica, as of the rest of Greece, is very mountainous, and between the mountain chains lie several plains of no great size, open on one side to the sea. On the west its natural boundary is the Corinthian Gulf, so that it would include the district of Megaris; and, as a matter of fact, before the Dorian invasion, which resulted in the foundation of Megara, the whole of this country was politically one, being in the hands of the Ionian race. This is proved by the column which, as we learn from Strabo, once stood on the Isthmus of Corinth, bearing on one side the inscription, "This land is Peloponnesus, not Ionia"—

*τῶν γὰρ Πελοπόννησος, οὐκ Ἰωνία—*

and on the other, "This land is not Peloponnesus, but Ionia"—

*τῶν οὐκ Πελοπόννησος, ἀλλ' Ἰωνία.*

The central position of Attica in Greece was one main cause of its historical importance. When K. O. Müller compares Greece to a body, whose members are different in form, while a mutual connection and dependence naturally exist between them, he speaks of Attica as one of the extremities which served as the active instruments of the body of Greece, and by which it was kept in constant connection with other countries. Hence in part arose the maritime character of its inhabitants; and when they had once taken to the sea, the string of neighbouring islands, Ceos, Cythnos, and others, some of which lay within sight of their coasts, and from one to another of which it was possible to sail without losing sight of land, served to tempt them on to further enterprises. Similarly on land, the post it occupied between Northern Greece and the Peloponnese materially influenced its relation to other states, both in respect of its alliances, such as that with Thessaly, towards which country it was drawn by mutual hostility to Bœotia, which lay between them,—a friendship of great service to Athens, because it brought to her aid the Thesalian cavalry, an arm with which she herself was feebly provided; and also in respect of offensive combinations of other powers, as that between Thebes and Sparta, which throughout an important part of Greek history were closely associated in their politics, through mutual dread of their powerful neighbour.

The mountains of Attica, which form its most characteristic feature, are to be regarded as a continuation of that chain which, starting from Mount Tymphrestus at the southern extremity of Pindus, passes through Phocis and Bœotia under the well-known names of Parnassus and Helicon; from this proceeds the range which, as Cithæron in its western and Parnes in its eastern portion, separates Attica from Bœotia, throwing off spurs southward towards the Saronic Gulf in Ægaleos and Hymettus, which bound the plain of Athens. Again, the eastern extremity of Parnes is joined by another line of hills, which, separating from Mount Ceta, skirts the Euboic Gulf, and, after entering Attica, throws up the lofty pyramid of Pentelicus, overlooking the plain of Marathon, and then sinks towards the sea at Sunium to rise once more in the outlying islands. Finally, at the extreme west of the whole district, Cithæron is bent round at right angles in the direction of the isthmus, at the northern approach to which it abuts against the mighty mass of Mount Geraneia, which is interposed between the Corinthian and the Saronic Gulf. The elevation reached by some of these is considerable, both Cithæron and Parnes being about 4600 feet, Hymettus 3360, and Pentelicus 2560, while Ægaleos does not rise higher than 1536 feet. At the present day they are extremely bare, and, to one who is accustomed to Italian scenery, their severity is apt at first to be almost repellent; but after a time the eye is delighted with the delicacy of the outlines, the minute articulation of the minor ridges and valleys, and the symmetrical way in which nature has grouped the several mountains so as to form a balance between them. The appearance thus produced can be best described as classical.

The soil of Attica is light and thin, and requires very careful agriculture to develop its produce. This feature belongs not only to the rocky mountain sides, but to some extent also to the maritime plains, and had considerable influence on the development of the inhabitants, both by enforcing industrious habits, and in leading them at an early period to take to the sea. Still, the level ground was sufficiently fertile to form a marked contrast to the rest of the district, and this fact is represented in the mythical genealogy of the early kings, which embodies several geographical features. Thus, while first we find the name of Actæus or Actæon, who represents the ἀκτῆ or sea-coast,

later on occurs Cranaus, a personification of the rocky ground, whence both Pindar and Aristophanes apply the epithet *κραναῖα* to Athens; and further we meet with Erichthonius, whose name is intended to express the fruitful plains. Thucydides attributes to the nature of the thin soil (i. 2, τὸ λεπτόγειον), which presented no attraction to invaders, the permanence of the same inhabitants in the country, whence arose the claim to indigenoueness on which the Athenians so greatly prided themselves; while at the same time the richer ground fostered that fondness for country life, which is proved by the enthusiastic terms in which it is always spoken of by Aristophanes, and by the discontent of the people of Attica at being forced to betake themselves to the city at the commencement of the Peloponnesian War. That we are not justified in judging of the ancient condition of the soil by the aridity which prevails at the present day, is shown by the fact that out of the 174 demes into which Attica was divided, at least one-tenth were named from trees or plants.

But whatever drawbacks the people of Attica experienced in respect of the soil were more than compensated by the fineness of the climate. In this point they enjoyed a great advantage over their neighbours the Bœotians; and while at the present day travellers speak of the excessive heat in summer and cold in winter which they have experienced in Bœotia, Attica has always been famous for its mildness. In approaching this district from the north, a change of temperature is felt as soon as a person descends from Cithæron or Parnes, and the sea breeze, which in modern times is called ὁ ἐμβάτης, or that which sets towards shore, moderates the heat in summer. Both the Attic comedians and Plato speak with enthusiasm of their native climate, and the fineness of the Athenian intellect was attributed to the clearness of the Attic atmosphere. It was in the neighbourhood of Athens itself that the air was thought to be purest. This is what Euripides refers to in the well-known passage where he describes the inhabitants as "ever walking gracefully through the most luminous æther" (*Med.*, 829); and Milton, who is always an admirable exponent of Greek literature, in like manner says—

"Where, on the Ægean shore, a city stands,  
Built nobly, pure the air, and light the soil,—  
Athens, the eye of Greece."

Thus it is hardly hyperbole in Xenophon to say "one would not err in thinking that this city is placed near the centre of Greece—nay, of the civilised world,—because, the farther removed persons are from it, the sorer is the cold or heat they meet with" (*Œcigal.*, i. 6). To the clearness of the atmosphere must be referred the distinctness with which distant objects can be discerned, for from the Acropolis the lines of white marble that streak the sides of Pentelicus are visible, and also the brilliant colouring which is so conspicuous in an Athenian sunset. Thus Dean Stanley speaks of "the flood of fire with which the marble columns, the mountains, and the sea are all bathed and penetrated;" "the violet hue which Hymettus assumes in the evening sky, in contrast to the glowing furnace of the rock of Lycabettus, and the rosy pyramid of Pentelicus." And M. Bursian says—"Amongst the most beautiful natural scenes that I have beheld I reckon the sight of Hymettus from Athens at sunset, whilst the entire range, as soon as the sun begins to sink, quivers with the loveliest rosy red, which gradually passes through the most varied gradations into the deepest violet. No one who has not enjoyed this spectacle can understand the *purpureos colles florentis Hymetti* of Ovid." This otherwise perfect climate is slightly marred by the prevalence of the north wind. This is expressed on the Horologium of Antonius Cyrrhæstus, called the Temple or Tower of the Winds, at

Athens, where Boreas is represented as a bearded man of stern aspect, thickly clad, and wearing strong buskins; he blows into a conch shell, which he holds in his hand as a sign of his tempestuous character. This also explains the close connection between him and this country in mythology, especially in the legend of Orithyia, who is the daughter of the Cephissus, thus representing the mists that rise from the streams, and whom he carries off with him and makes his wife. One of their offspring is called Chione, or the Snow Maiden.

When we turn to the vegetation of Attica, the olive first calls for our attention. This tree, we learn from Herodotus (v. 82), was thought at one time to have been found in that country only; and the enthusiastic praises of Sophocles (*Ed. Col.*, 700) teach us that it was the land in which it flourished best. So great was the esteem in which it was held, that in the early legend of the struggle between the gods of sea and land, Poseidon and Athena, for the patronage of the country, the sea-god is represented as having to retire vanquished before the giver of the olive; and at a later period the evidences of this contention were found in an ancient olive tree in the Acropolis, together with three holes in the rock, said to have been made by the trident of Poseidon, and to be connected with a salt well hard by. The fig also found its favourite home in this country, for Demeter was said to have bestowed it as a gift on the Eleusinian Phytalus, i.e., "the gardener." Both Cithæron and Parnes must have been wooded in former times; for on the former are laid the picturesque silvan scenes in the *Bacchæ* of Euripides, and it was from the latter that the wood came which caused the neighbouring deme of Acharnæ to be famous for its charcoal—the *ἀρπύριος* Παρπίριος of the *Acharnians* of Aristophanes (348). It was the thymy slopes of Hymettus, too, from which came the famous Hymettian honey. Among the other products we must notice the marble—both that of Pentelicus, which afforded a material of unrivalled purity and whiteness for building the Athenian temples, and the blue marble of Hymettus—the *trabes Hymettias* of Horace—which used to be transported to Rome for the construction of palaces. But the richest of all the sources of wealth in Attica was the silver mines of Laureium, the yield of which was so considerable as to render silver the principal medium of exchange in Greece, so that "a silver piece" (*ἀργύριον*) was the Greek equivalent term for money. Hence Æschylus speaks of the Athenians as possessing a "fountain of silver" (*Per.*, 235), and Aristophanes makes his chorus of birds promise the audience that, if they show him favour, owls from Laureium, i.e., silver pieces with the emblem of Athens, shall never fail them (*Av.*, 1106). In Strabo's time, though the mines had almost ceased to yield, silver was obtained in considerable quantities from the scoria; and at the present day a large amount of lead is obtained in the same way, the value of what was exported in 1869 having been £177,000 sterling.

Having thus noticed the general features of the country, let us proceed to examine it somewhat more in detail. It has been already mentioned that the base line is formed by the chain of Cithæron and Parnes, running from west to east; and that from this transverse chain run southward, dividing Attica into a succession of plains. The westernmost of these, which is separated from the innermost bay of the Corinthian Gulf, called the Mare Alcyonium, by an offshoot of Cithæron, and is bounded on the east by a ridge which ends towards the Saronic Gulf in a striking two-horned peak called Kerata, is the plain of Megara. It is only for geographical purposes that we include this district under Attica, for both the Dorian race of the inhabitants, and its dangerous proximity to Athens, caused it to be at perpetual feud with that city; but its position

as an outpost for the Peloponnesians, together with the fact of its having once been Ionian soil, sufficiently explains the bitter hostility of the Athenians towards the Megarians. The great importance of Megara arose from its commanding all the passes into the Pæloponnese. These were three in number: one along the shores of the Corinthian Gulf, which, owing to the nature of the ground, makes a long detour; the other two starting from Megara, and passing, the one by a lofty though gradual route over the ridge of Geraneia, the other along the Saronic Gulf, under the dangerous precipices of the Scironian rocks. The town of Megara, which was built on and between two low hills rising out of the plain rather more than a mile from the sea, had the command of both gulfs by means of its two ports—that of Pegæ on the Corinthian, and that of Nicaea on the Saronic. The necessities of the case occasionally brought the Megarians and their powerful neighbours together; for the former greatly depended on Athens for their supplies, as we see from their famished state, as described by Aristophanes in the *Acharnians* (729 seq.), when excluded from the ports and markets of that country.

(To the east of the plain of Megara lies that of Eleusis, bounded on the one side by the chain of Kerata, and on the other by that of Ægælea, through a depression in which was the line of the sacred way, where the torchlight processions from Athens used to descend to the coast, the "brightly-gleaming shores" (*λαμπρότεροι ἄκται*) of Sophocles (*Ed. Col.*, 1049). Here a deep bay runs into the land, opposite to which, and separated from it by a strait, which forms a succession of graceful curves, was the rocky island of Salamis, at all times an important possession to the Athenians on account of its proximity to their city. The scene of the battle of Salamis was the narrowest part of this channel, where the island approaches the extremity of Ægælea; and it was on the last declivities of that mountain that—

"A king sits on the rocky brow  
Which looks o'er sea-born Salamis."

The eastern portion of this plain was called the Thriassian plain, and the city of Eleusis was situated in the recesses of the bay. The coast-line of this part, between the sanctuary of Poseidon at the isthmus, which was originally Ionian, and Athens, is the principal scene of the achievements of Theseus, a hero who holds the same relation to the Ionians of Greece proper as Hercules does to the Greeks at large, viz., that of being the great author of improvements in the country. In this instance his feats seem to describe the establishment of a safe means of communication. On the isthmus itself he destroys the monster Sinis, the "ravager," otherwise called Pityocampetes, or the "pine-bender," which names imply that he is the embodiment of a violent wind, though the legend grew up that he fastened his victims to the bent branches of two pines, by the rebound of which they were torn in sunder. His next exploit is near Crommyon, where he destroys a wild sow, called Phæa, or "the dusky," which probably means that he checked a torrent, since violent water-courses are often represented by that animal in Greek mythology. Then follows the struggle with the brigand Sciron, who signifies the dangerous wind, which blows with such violence in this district that at Athens the north-west wind received the name of Sciron from the neighbouring Scironian rocks; the pass, which skirts the sea at the base of the cliffs, is now known by the ill-omened title of Kake Scala, and is still regarded as a perilous transit. Finally, between Eleusis and Athens, Theseus overcomes Procrustes, or "the racker," who apparently represents the dangers of the pass between Eleusis and Athens, now called Daphne; for the ridge of Mount Ægælea hard by was in ancient

times called Corydallas, and this, we are told by Diodorus (iv. 59), was the scene of the contest.

Next in order to the plain of Eleusis came that of Athens, which is the most extensive of all, reaching from the foot of Parnes to the sea, and bounded on the west by Ægaleos, and on the east by Hymettus. Its most conspicuous feature is the broad line of dark green along its western side, formed by the olive-groves of Colonus and the gardens of the Acæfemus, which owe their fertility to the waters of the Cephissus, by which they are irrigated. This river is fed by copious sources on the side of Mount Parnes, and thus, unlike the other rivers of Attica, has a constant supply of water; but it does not reach the sea, nor did it apparently in classical times, having been diverted, then as now, into the neighbouring plantations; for this is what Sophocles means when he speaks of "the sleepless fountains of Cephissus, which stray forth from their channels" (*Ed. Col.*, 635 *seq.*). The position of Colonus itself is marked by two bare knolls of light-coloured earth, which caused the poet in the same chorus to apply the epithet "white" (*ἀργήρα*) to that place. On the opposite side of the plain runs the other river, the Ilissus, which rises from a beautiful fountain in Mount Hymettus, and skirts the eastern extremity of the city of Athens; but this, notwithstanding its celebrity, is a mere brook, which stands in pools a great part of the year, and in summer is completely dry. The situation of Athens relatively to the surrounding objects is singularly harmonious; for, while it forms a central point, so as to be the eye of the plain, and while the altar-rock of the Acropolis and the hills by which it is surrounded are conspicuous from every point of view, there is no such exactness in its position as to give formality, since it is nearer to the sea than to Parnes, and nearer to Hymettus than to Ægaleos. The most striking summit in the neighbourhood of the city is that of Lycabettus, now Mount St George, on the north-eastern side; and the variety is still further increased by the continuation of the ridge which it forms for some distance northwards through the plain. Three roads lead to Athens from the Boeotian frontier over the intervening mountain barrier—the easternmost over Parnes, from Delium and Oropus by Deceleia, which was the usual route of the invading Lacedæmonians during the Peloponnesian War; the westernmost over Cithæron, by the pass of Dryosephale, or the "Oakheads," leading from Thebes by Plateæ to Eleusis, and so to Athens, which we hear of in connection with the battle of Plateæ, and with the escape of the Plateæans at the time of the siege of that city in the Peloponnesian War; the third, midway between the two, by the pass of Phyle, near the summit of which, on a rugged height overlooking the Athenian plain, is the fort occupied by Thrasylbulus in the days of the Thirty Tyrants. On the sea-coast to the south-west of Athens rises the hill of Munychia, a mass of rocky ground, forming the acropolis of the town of Piræus, which was once separated from the mainland; for Strabo (i. 3, § 18) speaks of it as having been formerly an island. On one side of this, towards Hymettus, lay the open roadstead of Phalerum, on the other the harbour of Piræus, a completely land-locked inlet, safe, deep, and spacious, the approach to which was still further narrowed by moles. The eastern side of the hill was further indented by two small but commodious havens, which were respectively called Zea and Munychia.

The north-eastern boundary of the plain of Athens is formed by the graceful pyramid of Pentelicus, which received its name from the deme of Pentele at its foot, but was far more commonly known as Brilessus in ancient times. This mountain did not form a continuous chain with Hymettus, for between them intervenes a level space of ground two miles in width, which formed the entrance to the

Mesogæa, an elevated undulating plain in the midst of the mountains, reaching nearly to Sunium. At the extremity of Hymettus, where it projects into the Saronic Gulf, was the promontory of Zoster, or "the Girdle," which was so called because it girdles and protects the neighbouring harbour; but in consequence of the name, a legend was attached to it, to the effect that Latona had loosed her girdle there. From this promontory to Sunium there runs a lower line of mountains, and between these and the sea a fertile strip of land intervenes, which was called the Paralia. Beyond Sunium, on the eastern coast, were two safe ports, that of Thoricus, which is defended by the island of Helene, forming a natural breakwater in front of it, and that of Prasia, now called Porto Rapti, or "the Tailor," from a statue at the entrance to which the natives have given that name. But it still remains to mention the most famous spot of ground in Attica, the little plain of Marathon, which lay in the north-east corner, encircled on three sides by Parnes and Pentelicus, while the fourth faces the sea and the opposite coast of Eubœa. It was on the mountain slopes that the Greeks were stationed, while the Persians with their ships occupied the coast; and on the two sides the marshes may still be traced by which the movements of the invader's host were impeded. The mound, which at once attracts the eye in the centre of the level plain, is probably the burial-place of the Athenians who fell in the battle. The bay in front is sheltered by Eubœa, and is still more protected from the north by a projecting tongue of land, called Cynosura. The mountains in the neighbourhood were the seat of one of the political parties in Attica, the Diacrii or Hyperacrii, who, being poor mountaineers, and having nothing to lose, were the principal advocates of change; while, on the other hand, the Pedieis, or inhabitants of the plains, being wealthy landholders, formed the strong conservative element, and the Parali, or occupants of the sea-coast, representing the mercantile interest, held an intermediate position between the two. Finally, there was one district of Attica, that lay without its natural boundaries, the territory of Oropus, which properly belonged to Boeotia, as it was situated to the north of Parnes; but on this the Athenians always endeavoured to retain a firm hold, because it facilitated their communications with Eubœa. The command of that island was of the utmost importance to them; for, if Ægina could rightly be called "the eyesore of the Piræus," Eubœa was quite as truly a thorn in the side of Attica; for we learn from Demosthenes (*De Cor.*, p. 307) that at one period the pirates that made it their headquarters so infested the neighbouring sea as to prevent all navigation.

Of the condition of Attica in mediæval and modern times little need be said, for it has followed for the most part the fortunes of Athens. The population, however, has undergone a great change, independently of the large admixture of Slavonic blood that has affected the Greeks of the mainland generally, by the immigration of Albanian colonists, who now occupy a great part of the country. The most important of the classical ruins that remain outside Athens are those of the temple of Athena at Sunium, which form a conspicuous object as they surmount the headland, and gave rise to the name which it bore, until lately, of Cape Colonus; it is in the Doric style, of white marble, and 13 columns of the temple and a pilaster are now standing. At Eleusis the foundations of the *propyleæ* of the great temple of Demeter and other buildings have been laid bare by excavation; at Thoricus there are remains of an ancient theatre; and at Rhamnus, northward from Marathon, at a little distance from the sea, are the basements and some of the columns of two temples in the same enclosure, which were dedicated to Nemesis and Themis.

(H. F. T.)



**ATTICUS, TITUS POMONIUS**, the friend of Cicero, was one of the most distinguished men during the period of the decline and fall of the Roman republic. His life gives an admirable picture of the classical man of culture, who, withdrawing from the stir of political affairs, devoted himself to literary and artistic pursuits. He was born at Rome 109 B.C., and was thus three years older than Cicero, along with whom he and the younger Marius were educated. His family is said to have been of noble and ancient descent; his father belonged to the equestrian order, and was very wealthy. When Pomponius (who afterwards received the surname Atticus, on account of his long residence at Athens, and his intimate acquaintance with Greek literature) was still a young man, his father died, and he at once took the prudent resolution of transferring himself and his fortune to Athens, in order to escape the dangers of the civil war, in which he might have been involved through his connection with the murdered tribune Sulpicius Rufus. Here, in retirement, he contrived to keep himself free from the entanglements of faction, while preserving friendly relations with all parties. Sulla, who urged him to come to Rome and join his party, took no offence at his refusal, but treated him with marked kindness. He assisted the younger Marius and Brutus with money when they were fleeing from their enemies, and remained on the most cordial terms with Cæsar and Pompey, Antony and Octavianus. His most intimate friend, however, was Cicero, whose correspondence with him extended over many years, and who seems to have found his prudent counsel and sympathy a remedy for all his many troubles. His private life was tranquil and happy. He did not marry till he was 53 years of age, and his only child became the wife of Vipsanius Agrippa, the distinguished minister of Augustus. His large fortune was increased on the death of his uncle, L. Cæcilius, who bequeathed to him the greater part of his property. He formed a large library at Athens, and kept a staff of slaves engaged in making copies of valuable works. He probably derived considerable profits from the sale of these books. In 32 B.C. he was seized with an illness believed to be incurable. He resolved not to protract a painful and hopeless struggle, and died after five days of voluntary starvation. As might have been expected from his easy temper and equable disposition, Atticus professed a mild Epicureanism, but philosophical problems, as such, do not seem to have had much interest for him; he was emphatically a man of literature. Of his writings none are extant, but we have notices of two, one a Greek history of Cicero's consulship, the other, in Latin, on Roman annals, a subject to which he had given much attention. This work was highly commended for its minute exactness, chronological accuracy, and simple style.

**ATTICUS HERODES, TIBERIUS CLAUDIUS**, a very wealthy citizen of Athens, was born about 104 A.D. His grandfather's estates had been confiscated for treachery, but the fortunes of the family had been restored by the discovery in his father's house of an enormous sum of money, which the Emperor Nerva permitted them to retain. This great wealth Herodes afterwards increased by his marriage. He received a careful education under the most distinguished masters of the time, and specially devoted himself to the study of oratory, to excel in which seems to have been the ruling motive of his life. While very young he delivered a speech before one of the emperors; but it was so ill received that he was with difficulty restrained from throwing himself into the Danube. He ultimately attained to great celebrity as a speaker and as a teacher of rhetoric. Among his pupils were Marcus Aurelius and Læcius Verus. He was highly esteemed by the Antonines, particularly by Aurelius, and received many marks of favour, among others the archonship at Athens and the

consulate at Rome. Atticus is principally celebrated, however, for the vast sums he expended on public purposes. He built at Athens a great race-course of marble from Pentelicus, and a splendid musical theatre, called the Odeum. At Corinth he built a theatre, at Delphi a stadium, at Thermopylæ hot baths, at Cannanum in Italy an aqueduct. He even contemplated cutting a canal through the Isthmus of Corinth, but it is said did not dare to carry out his plan because the same thing had been unsuccessfully attempted before by the Emperor Nero. Many of the partially ruined cities of Greece were restored by Atticus, and numerous inscriptions testify their gratitude to his benefactor. His wealth, and, it is reported, some disagreement with regard to one of the provisions of his father's will, roused up the enmity of the Athenians against him. He withdrew from Athens, and resided at his villa near Marathon, where he died about 180 A.D. None of his writings are extant.

**ATILIA, or EZZEL**, the famous leader of the Huns, surnamed the "Fear of the World," or the "Scourge of God," was born probably about 406 A.D. His father Mundzuk, king of the Huns, was succeeded by his brothers Octar and Rhuas; and on the death of Rhuas, in 434, Attila and his brother Bleda together ascended the throne. They ruled not only over the Huns, but over nearly all the tribes north of the Danube and the Black Sea; under their banners fought Ostrogoths, Gepidae, Alani, Héruli, and many other Teutonic peoples. Their dominions are said to have extended from the Rhine to the frontiers of China. Attila was superstitiously revered by his countrymen; he was said to possess the iron sword of the war-god, Mars, and he proclaimed himself to be the man-child born at Engaddi, who was destined to rule over the whole world. In 441 and 442 the brothers ravaged Thrace and Illyria, defeated the troops of the Eastern Empire in three great battles, and penetrated as far as Thermopylæ. Peace was made on the Romans agreeing to pay a heavy tribute. About this time Attila contrived to make away with his brother Bleda, and thus secured undivided supremacy. In 445 and the following years, he again directed his attacks against the Eastern Empire, and laid waste the whole country round Constantinople. Nowhere did he meet with resistance save from the brave little town of Azimus. The empire seemed about to succumb, when Theodosius entered into negotiations and made terms with his conqueror. While matters were being arranged, a plot was laid to assassinate Attila, in which the emperor was implicated. The conspiracy was discovered, and the barbarian upbraided the Christian monarch with his want of honour and manly courage. Theodosius died soon after, and his successor, Marcian, returned a firm refusal to Attila's demands for tribute. War seemed inevitable; but at this time the attention of the Hun was drawn to the Western Empire. It is said that the Princess Honoria, sister of Valentinian, tired of her life of enforced celibacy, sent her ring and an offer of her hand to Attila, who upon this grounded his claim to a part of the empire. It is probable, however, that he merely used this as a pretext, and that his real designs were more comprehensive. He evidently thought it a favourable opportunity for taking advantage of the enmity between the Romans and the Visigoths; and to this plan he was also induced by the proposals of Genseric, king of the Vandals, who offered to unite with him against his rival, Theodoric, king of the Visigoths. In 451 Attila assembled his forces, it is said 700,000 strong, led them through the centre of Germany, probably by Franconia, and crossed the Rhine, at what place cannot be determined. He defeated the Burgundians, and pushed on through the heart of Gaul, until his centre was checked by the valiant resistance offered

by Orleans. Meanwhile, Theodoric and Aëtius, the Roman general, had collected and united their forces, and marching with all speed, arrived in time to raise the siege of Orleans. Attila retreated to a position in the plain of Chalons, and there concentrated his forces for a great engagement. A tremendous battle ensued—one of the most gigantic as well as most important contests recorded in history. The Romans, who formed one wing, were driven back, and although they kept together, and at nightfall retired to the camp of the Visigoths, Aëtius had given up the day as lost. The Visigoths, who were on the other wing, had also been repulsed, and were discouraged by the fall of their leader Theodoric. But the fortune of the day was changed by the impetuous bravery of Thorismund, Theodoric's son, who, burning to avenge his father's fall, led on the infuriated Visigoths, and drove Attila back to his camp. He even penetrated into the fortifications, but was wounded and thrown from his horse, and his followers with difficulty carried him off. Next day, Attila remained in his camp in expectation of an attack, and having thrown all his baggage into a gigantic pile in the centre of the camp to be burned in case of defeat, resolved to sell his life dearly. But no attack was made; for Thorismund was persuaded by Aëtius to march to Toulouse in order to obtain his father's kingdom. Attila was thus enabled to retire in perfect security. Next year he poured his forces through the defiles of the Alps, and laid waste the whole north of Italy. Rome itself seemed likely to fall before the invader, when his course was arrested by an embassy headed by Pope Leo. Attila at once withdrew from Italy, but the motive which led him to act thus is not known. At the time his retreat was ascribed to a miraculous interposition of Providence, Peter and Paul having appeared in the camp of the Huns along with the embassy. The whole matter is rather obscure; and scarcely more credible is the story told by Jornandes that Attila invaded Gaul a second time and was completely defeated by Thorismund. No other historian mentions this circumstance. In the year 453, Attila died from the bursting of a blood-vessel on the night of his marriage with a beautiful Gothic maiden, called Ildiko, or Hilda. He was buried by his followers with great pomp and lamentation. The vast empire over which he had ruled broke up immediately after his death, no one chief being powerful enough to seize the supremacy. In person Attila is described as having been of true Hunnish type, short, but strongly made, with a large head, flat, wide-spread nostrils, and small glittering eyes. His presence was majestic and imposing, and he excelled all his followers in military exercises.

**ATTOCK**, a town and fort of British India, in the Panjáb, situated on the eastern bank of the Indus, in 33° 54' N. lat., and 72° 20' E. long. The place is both of political and commercial importance, as the Indus is here crossed by the military and trade route through the Khaibar Pass into Afghanistan. Alexander the Great, Tamerlane, and Nádír Sháh, are believed to have successively crossed the Indus at or about this spot in their respective invasions of India. The river runs past Attock in a deep rapid channel about 200 yards broad, but is easily crossed in boats or on inflated skins of oxen. A bridge of boats is maintained for a considerable part of the year, but withdrawn in the summer as soon as the melting of the snows in the northern mountains endangers it. The fort of Attock was built by the Emperor Akbar in 1581, on a low hillock beside the river. The walls are of polished stone, and the whole structure is handsome; but from a military point of view it is of little importance, being commanded by a hill, from which it is divided only by a ravine. The town was formerly a place of importance, but has now fallen into decay. On the opposite side of

the river is the village of Khairábád, with a fort, also erected by Akbar according to some, or by Nádír Sháh according to others.

**ATTORNEY**, in *English Law*, signifies, in its widest sense, any substitute or agent appointed to act in "the turn, stead, or place of another." The term is now commonly confined to a class of qualified agents who undertake the conduct of legal proceedings for their clients. By the common law the actual presence of the parties to a suit was considered indispensable, but the privilege of appearing by attorney was conceded in certain cases by special dispensation, until the statute of Merton and subsequent enactments made it competent for both parties in all judicial proceedings to appear by attorney. Solicitors appear to have been at first distinguished from attorneys, as not having the attorney's power to bind their principals, but latterly the distinction has been between attorneys as the agents formally appointed in actions at law, and solicitors who take care of proceedings in Parliament, Chancery, Privy Council, &c. In practice, however, and in ordinary language, the terms are synonymous. Regulations regarding the qualification of attorneys are found as far back as the 20 Edward I., which required the judges to select in each county the most learned and able attorneys and apprentices to do service in the courts. By the 6 and 7 Vict. c. 73, and other statutes, the qualifications necessary for admission on the rolls of attorneys and solicitors are:—1st, The due execution of a proper contract in writing with some practising attorney or solicitor for the term of five years, or of three years if the clerk be a graduate of the universities of Oxford, Cambridge, Dublin, London, or Durham, or of the Queen's University, Ireland, or if he have been a member of the bar, a writer to the signet, a solicitor before the supreme courts in Scotland, or for ten years *bona fide* managing clerk to an attorney; 2d, The payment of the stamp duty on such contract, amounting to £80; 3d, The registry or enrolment of the contract within six calendar months; 4th, Actual service for the prescribed period in the proper business of an attorney and solicitor; but one year may be served with the London agent, and, where the service is for five years, another year with a barrister or certificated special pleader; 5th, Due notices of the application to be admitted; 6th, Fitness and capacity ascertained upon examination, and certified by the examiners; 7th, Taking the prescribed oaths, and being admitted and enrolled; 8th, The certificate of the registrar of attorneys that he is duly enrolled, and the stamped certificate of the annual payment of the duty. Attorneys duly admitted in any of the superior courts have a right to be admitted and to practise in any of the courts in the kingdom, and this right may be enforced by mandamus. They may act as advocates in certain of the inferior courts. Conveyancing, formerly considered the exclusive business of the bar, is now often performed by attorneys. Barristers are understood to require the intervention of an attorney in all cases that come before them professionally, although in criminal cases the prisoner not unfrequently engages a counsel directly by giving him a fee in open court. The relation of attorney and client disqualifies the former from dealing with his client on his own behalf, while it gives him a lien, on professional services, over the deeds, &c., of the client in his possession. An attorney may be struck off the rolls for professional or other misconduct, on application by counsel at the instance of an injured party, or, as the case generally is, of the Incorporated Law Society as representing the profession.

A *letter or power of Attorney* is an authority under hand and seal, empowering the person named therein to do some act on behalf of the principal, which otherwise could only be done by the principal himself. It expires with death of the

principal, and is revocable at his will, unless it has been given for a valuable consideration. A *warrant of Attorney* is an authority to one or more attorneys to appear for the party executing it, in a court of record, at the suit of the person for whose benefit it is given, and to suffer judgment summarily to pass in his favour. It is usually given as a security to creditors for the summary recovery of money lent, or sums certain, but may be used in other cases also.

ATTORNEY-GENERAL, the chief law officer appointed to manage all the legal affairs and suits in which the Crown is interested. He is appointed by patent, authorising him to hold office during the Queen's pleasure. He is *ex officio* the leader of the bar, and only counsel of the highest eminence are appointed to the office. The royal mandate of 14th December 1814 gives him precedence in all the courts, and it is now settled that in the House of Lords he has precedence of the Lord Advocate, even in Scotch appeals. He is a necessary party to all proceedings affecting the Crown, and has extensive powers of control in matters relating to charities, lunatics' estates, criminal prosecutions, &c. His assistant, also appointed by patent, is the Solicitor-General, who has full power to act in the absence of his principal, and by almost invariable usage, succeeds to his office when it becomes vacant. The income attached to these offices has hitherto been derived in great part from fees on patents for inventions, but by a recent arrangement the Attorney-General and Solicitor-General receive a salary of £7000 and £6000 respectively, exclusive of such fees as they may receive for any litigious business they may conduct on behalf of the Crown.

ATTRACTION. That the different parts of a material system influence each other's motions is a matter of daily observation. In some cases we cannot discover any material connection extending from the one body to the other. We call these cases of action at a distance, to distinguish them from those in which we can trace a continuous material bond of union between the bodies. The mutual action between two bodies is called stress. When the mutual action tends to bring the bodies nearer, or to prevent them from separating, it is called tension or attraction. When it tends to separate the bodies, or to prevent them from approaching, it is called pressure or repulsion. The names tension and pressure are used when the action is seen to take place through a medium. Attraction and repulsion are reserved for cases of action at a distance. The configuration of a material system can always be defined in terms of the mutual distances of the parts of the system. Any change of configuration must alter one or more of these distances. Hence the force which produces or resists such a change may be resolved into attractions or repulsions between those parts of the system whose distance is altered.

There has been a great deal of speculation as to the cause of such forces, one of them, namely, the pressure between bodies in contact, being supposed to be more easily conceived than any other kind of stress. Many attempts have therefore been made to resolve cases of apparent attraction and repulsion at a distance into cases of pressure. At one time the possibility of attraction at a distance was supposed to be refuted by asserting that a body cannot act where it is not, and that therefore all action between different portions of matter must be by direct contact. To this it was replied that we have no evidence that real contact ever takes place between two bodies, and that, in fact, when bodies are pressed against each other and in apparent contact, we may sometimes actually measure the distance between them, as when one piece of glass is laid on another, in which case a considerable pressure must be applied to bring the surfaces near enough to show the black spot of Newton's rings, which indicates a distance of

about a ten thousandth of a millimetre. If, in order to get rid of the idea of action at a distance, we imagine a material medium through which the action is transmitted, all that we have done is to substitute for a single action at a great distance a series of actions at smaller distances between the parts of the medium, so that we cannot even thus get rid of action at a distance.

The study of the mutual action between the parts of a material system has, in modern times, been greatly simplified by the introduction of the idea of the energy of the system. The energy of the system is measured by the amount of work which it can do in overcoming external resistances. It depends on the present configuration and motion of the system, and not on the manner in which the system has acquired that configuration and motion. A complete knowledge of the manner in which the energy of the system depends on its configuration and motion, is sufficient to determine all the forces acting between the parts of the system. For instance, if the system consists of two bodies, and if the energy depends on the distance between them, then if the energy increases when the distance increases, there must be attraction between the bodies, and if the energy diminishes when the distance increases, there must be repulsion between them. In the case of two gravitating masses  $m$  and  $m'$  at a distance  $r$ , the part of the energy which depends on  $r$  is  $-\frac{mm'}{r}$ . We may therefore express

the fact that there is attraction between the two bodies by saying that the energy of the system consisting of the two bodies increases when their distance increases. The question, therefore, Why do the two bodies attract each other? may be expressed in a different form. Why does the energy of the system increase when the distance increases?

But we must bear in mind that the scientific or science-producing value of the efforts made to answer these old standing questions is not to be measured by the prospect they afford us of ultimately obtaining a solution, but by their effect in stimulating men to a thorough investigation of nature. To propose a scientific question presupposes scientific knowledge, and the questions which exercise men's minds in the present state of science may very likely be such that a little more knowledge would show us that no answer is possible. The scientific value of the question, How do bodies act on one another at a distance? is to be found in the stimulus it has given to investigations into the properties of the intervening medium.

Newton, in his *Principia*, deduces from the observed motions of the heavenly bodies the fact that they attract one another according to a definite law. This he gives as a result of strict dynamical reasoning, and by it he shows how not only the more conspicuous phenomena, but all the apparent irregularities of the celestial motions are the calculable results of a single principle. In his *Principia* he confines himself to the demonstration and development of this great step in the science of the mutual action of bodies. He says nothing there about the means by which bodies gravitate towards each other. But his mind did not rest at this point. We know that he did not believe in the direct action of bodies at a distance.

"It is inconceivable that inanimate brute matter should, without the mediation of something else which is not material, operate upon and affect other matter without mutual contact, as it must do if gravitation in the sense of Epicurus is essential and inherent in it. . . . That gravity should be innate, inherent, and essential to matter, so that one body can act upon another at a distance, through a vacuum, without the mediation of anything else, by and through which their action and force may be conveyed from one to another, is to me so great an absurdity, that I believe no man, who has in philosophical matters a competent faculty of thinking, can ever fall into it."—*Letter to Bentley*.

And we also know that he sought for the mechanism of

gravitation in the properties of an aethereal medium diffused over the universe.

"It appears, from his letters to Boyle, that this was his opinion early, and if he did not publish it sooner it proceeded from hence only, that he found he was not able, from experiment and observation, to give a satisfactory account of this medium and the manner of its operation in producing the chief phenomena of nature."<sup>1</sup>

In his *Optical Queries*, indeed, he shows that if the pressure of this medium is less in the neighbourhood of dense bodies than at great distances from them, dense bodies will be drawn towards each other, and that if the diminution of pressure is inversely as the distance from the dense body the law will be that of gravitation. The next step, as he points out, is to account for this inequality of pressure in the medium; and as he was not able to do this, he left the explanation of the cause of gravity as a problem to succeeding ages. As regards gravitation the progress made towards the solution of the problem since the time of Newton has been almost imperceptible. Faraday showed that the transmission of electric and magnetic forces is accompanied by phenomena occurring in every part of the intervening medium. He traced the lines of force through the medium; and he ascribed to them a tendency to shorten themselves and to separate from their neighbours, thus introducing the idea of stress in the medium in a different form from that suggested by Newton; for, whereas Newton's stress was a hydrostatic pressure in every direction, Faraday's is a tension along the lines of force, combined with a pressure in all normal directions. By showing that the plane of polarisation of a ray of light passing through a transparent medium in the direction of the magnetic force is made to rotate, Faraday not only demonstrated the action of magnetism on light, but by using light to reveal the state of magnetisation of the medium, he "illuminated," to use his own phrase, "the lines of magnetic force."

From this phenomenon Thomson afterwards proved, by strict dynamical reasoning, that the transmission of magnetic force is associated with a rotatory motion of the small parts of the medium. He showed, at the same time, how the centrifugal force due to this motion would account for magnetic attraction.

A theory of this kind is worked out in greater detail in Clerk Maxwell's *Treatise on Electricity and Magnetism*. It is there shown that, if we assume that the medium is in a state of stress, consisting of tension along the lines of force and pressure in all directions at right angles to the lines of force, the tension and the pressure being equal in numerical value and proportional to the square of the intensity of the field at the given point, the observed electrostatic and electromagnetic forces will be completely accounted for.

The next step is to account for this state of stress in the medium. In the case of electromagnetic force we avail ourselves of Thomson's deduction from Faraday's discovery stated above. We assume that the small parts of the medium are rotating about axes parallel to the lines of force. The centrifugal force due to this rotation produces the excess of pressure perpendicular to the lines of force. The explanation of electrostatic stress is less satisfactory, but there can be no doubt that a path is now open by which we may trace to the action of a medium all forces which, like the electric and magnetic forces, vary inversely as the square of the distance, and are attractive between bodies of different names, and repulsive between bodies of the same names.

The force of gravitation is also inversely as the square of the distance, but it differs from the electric and magnetic forces in this respect, that the bodies between

which it acts cannot be divided into two opposite kinds, one positive and the other negative, but are in respect of gravitation all of the same kind, and that the force between them is in every case attractive. To account for such a force by means of stress in an intervening medium, on the plan adopted for electric and magnetic forces, we must assume a stress of an opposite kind from that already mentioned. We must suppose that there is a pressure in the direction of the lines of force, combined with a tension in all directions at right angles to the lines of force. Such a state of stress would, no doubt, account for the observed effects of gravitation. We have not, however, been able hitherto to imagine any physical cause for such a state of stress. It is easy to calculate the amount of this stress which would be required to account for the actual effects of gravity at the surface of the earth. It would require a pressure of 37,000 tons' weight on the square inch in a vertical direction, combined with a tension of the same numerical value in all horizontal directions. The state of stress, therefore, which we must suppose to exist in the invisible medium, is 3000 times greater than that which the strongest steel could support.

Another theory of the mechanism of gravitation, that of Le Sage, who attributes it to the impact of "ultramundane corpuscles," has been already discussed in the article *ATOM*, *supra*, p. 46.

Sir William Thomson<sup>2</sup> has shown that if we suppose all space filled with a uniform incompressible fluid, and if we further suppose either that material bodies are always generating and emitting this fluid at a constant rate, the fluid flowing off to infinity, or that material bodies are always absorbing and annihilating the fluid, the deficiency flowing in from infinite space, then, in either of these cases, there would be an attraction between any two bodies inversely as the square of the distance. If, however, one of the bodies were a generator of the fluid and the other an absorber of it, the bodies would repel each other.

Here, then, we have a hydrodynamical illustration of action at a distance, which is so far promising that it shows how bodies of the same kind may attract each other. But the conception of a fluid constantly flowing out of a body without any supply from without, or flowing into it without any way of escape, is so contradictory to all our experience, that an hypothesis, of which it is an essential part, cannot be called an *explanation* of the phenomenon of gravitation.

Dr Robert Hooke, a man of singular inventive power, in 1671 endeavoured to trace the cause of gravitation to waves propagated in a medium. He found that bodies floating on water agitated by waves were drawn towards the centre of agitation.<sup>3</sup> He does not appear, however, to have followed up this observation in such a way as to determine completely the action of waves on an immersed body.

Professor Challis has investigated the mathematical theory of the effect of waves of condensation and rarefaction in an elastic fluid on bodies immersed in the fluid. He found the difficulties of the investigation to be so great that he has not been able to arrive at numerical results. He concludes, however, that the effect of such waves would be to attract the body towards the centre of agitation, or to repel it from that centre, according as the wave's length is very large or very small compared with the dimensions of the body. Practical illustrations of the effect of such waves have been given by Guyot, Schellbach, Guthrie, and Thomson.<sup>4</sup>

A tuning-fork is set in vibration, and brought near a delicately suspended light body. The body is immediately

<sup>1</sup> *Proceedings of the Royal Society of Edinburgh*, 7th Feb. 1870.

<sup>2</sup> *Posthumous Works*, edited by R. Waller, pp. xiv. and 184.

<sup>4</sup> *Philosophical Magazine*, June 1871.

<sup>1</sup> Maclearin's account of Sir Isaac Newton's discoveries.

attracted towards the tuning-fork. If the tuning-fork is itself suspended, it is seen to be attracted towards any body placed near it.

Sir W. Thomson has shown that this action can in all cases be explained by the general principle that in fluid motion the average pressure is least where the average energy of motion is greatest. Now, the wave motion is greatest nearest the tuning-fork, the pressure is therefore least there; and the suspended body being pressed unequally on opposite sides, moves from the side of greater pressure to the side of less pressure, that is towards the tuning-fork. He has also succeeded in producing repulsion in the case of a small body lighter than the surrounding medium.

It is remarkable that of the three hypotheses, which go some way towards a physical explanation of gravitation, every one involves a constant expenditure of work. Le Sage's hypothesis of ultramundane corpuscules does so, as we have shown in the article *ATOM*. That of the generation or absorption of fluid requires, not only constant expenditure of work in emitting fluid under pressure, but actual creation and destruction of matter. That of waves requires some agent in a remote part of the universe capable of generating the waves.

According to such hypotheses we must regard the processes of nature not as illustrations of the great principle of the conservation of energy, but as instances in which, by a nice adjustment of powerful agencies not subject to this principle, an apparent conservation of energy is maintained. Hence, we are forced to conclude that the explanation of the cause of gravitation is not to be found in any of these hypotheses.

For the mathematical theory of attraction and attraction of ellipsoids, see *POTENTIAL*; for attraction of gravitation, capillary attraction, and attraction of cohesion, see respectively *GRAVITATION*, *CAPILLARY ATTRACTION*, and *CONSTITUTION OF BODIES*.  
(J. C. M.)

**ATWOOD, THOMAS**, musical composer, was born in London in 1767. As one of the boy choristers in the chapel royal he received his early instruction in music from Nares and Ayrton. In 1783 he was sent to study abroad at the expense of the Prince of Wales, who had been favourably impressed by his skill as a performer on the harpsichord. After spending two years at Naples, Atwood proceeded to Vienna, where he became a favourite pupil of Mozart. On his return to London he held for a short time an appointment as one of the chamber musicians to the prince of Wales. In 1795 he was chosen organist of St Paul's, and in the following year he succeeded Dr Dupuis as composer to the chapels royal. His court connection was further confirmed by his appointment as musical instructor to the duchess of York and afterwards to the princess of Wales. For the coronation of George IV. he composed the anthem, *The King shall Rejoice*, a work of high merit. The king, who had neglected him for some years on account of his connection with the princess of Wales, now restored him to favour, and in 1821 appointed him organist to his private chapel at Brighton. Soon after the institution of the Royal Academy of Music, Atwood was chosen one of the professors. He wrote the anthem, *O Lord, grant the King a Long Life*, which was performed at the coronation of William IV., and he was composing a similar work for the coronation of Queen Victoria when he died (March 24, 1838). Atwood's compositions are favourable specimens of the English school. His services and anthems were published in a collected form after his death by his pupil Walmealey, and are frequently used in cathedral worship. Of his secular compositions several songs and glees are well known and popular. The operas which he composed in early life are now almost

forgotten, belonging, as they do, to a period when English music was at its lowest ebb.

**ATWOOD, GEORGE**, an author celebrated for the accuracy of his mathematical and mechanical investigations, and considered particularly happy in the clearness of his explanations, and the elegance of his experimental illustrations, was born in the early part of the year 1746. He was educated at Westminster school, to which he was admitted in 1759. Six years afterwards he was elected of to Trinity College, Cambridge. He took his degree of Bachelor of Arts in 1769, with the rank of third wrangler and first Smith's prizeman. These distinctions were amply sufficient to give him a claim to further advancement in his own college. In due time he obtained a fellowship, and was afterwards one of the tutors of the college. He became Master of Arts in 1772, and in 1776 was elected a fellow of the Royal Society of London. In the year 1784 he ceased to reside at Cambridge, and soon afterwards received from Mr Pitt a patent office, which required but little of his attendance, and enabled him still to devote a considerable portion of his time to his special studies. He died in 1807. Atwood's published works, exclusive of papers contributed to the *Philosophical Transactions*, for one of which he obtained the Copley medal, are as follows:—(1.) *Analysis of a Course of Lectures on the Principles of Natural Philosophy*, Cambridge, 1784. (2.) *Treatise on the Rectilinear Motion and Rotation of Bodies*, Cambridge, 1784, which contains a good account of the elementary principles of mechanics, though it is deficient in the application of higher mathematical analysis. It also gives some interesting experiments, by means of which mechanical truths can be ocularily exhibited and demonstrated, and describes the machine, since called by Atwood's name, for verifying experimentally the laws of simple acceleration of motion. (3.) *Review of the Statutes and Ordinances of Assize which have been established in England from the 4th year of King John, 1202, to the 37th of his present Majesty*, London, 1801, a work of some historical research. (4.) *Dissertation on the Construction and Properties of Arches*, London, 1801, with supplement, pt. i. 1801, pt. ii. 1804, an elaborate and, in its time, valuable work, though it is now completely superseded.

**ATYS, ATTIS, or ATTES**, in the *Phrygian and Lydian Mythology*, a youth beloved for his beauty by the goddess Rhea, there called Agdistia. Like Adonis, he was a personification of the changes in nature, from the beauty of spring and summer to the severity and darkness of winter. The story, as told at Pessinus, the centre of the worship of the goddess, was that she had born to Zeus a being both male and female; that the gods, displeased, had transformed this being into a tree, from the fruit of which the daughter of the river-god Sangarius bore a boy, who grew up among herdsmen marvellous in his beauty, so as to win the love of Agdistia. This was Atys, and he was about to be married to the king's daughter of Pessinus, when the goddess appeared among the guests, terrified them, and caused Atys to run to the woods, where he maimed himself and was transformed into a pine tree; from his blood sprang violets. Agdistis begged Zeus to restore him, but he could only assure her that the youth would never decay, and that his hair would always grow. She conveyed the pine to her cave at Pessinus, and gave herself up to grief.

**AUBAGNE**, a town of France, in the department of Bouches-du-Rhône, with a population of 7408, who carry on the manufacture of wine, pottery, leather, coarse cloth, &c. The only remarkable monument is a fountain to the memory of the Abbé Barthélemy, whose family was long connected with the town.

**AUBE**, a department of France, bounded on the N. by the department of Marne, N.W. by Seine-et-Marne, W.

by Yonne, S. by Cote-d'Or, and E. by Haute-Marna. It consists of a portion of Champagne and Vallage, with a small part of Burgundy, and has an area of 2317 square miles. Its general inclination from S.E. to N.W. presents little variety of surface, the only elevations being a double line of hills along the course of the Seine, never exceeding 1150 feet in height. The department belongs to the Seine basin, and is watered by that river and its tributaries, the Ource, the Sarce, the Melda, and the Aube, &c. The climate is comparatively mild, but damp. Heavy rains fall at the beginning of winter. In the N. and N.W. the soil is dry and sterile; but the S. and E. districts are very fertile, particularly the valleys, which are admirably adapted for the cultivation of the vine. About two-thirds of the surface consists of arable land, and the agricultural condition of the country is improving. The principal productions are wheat, rye, oats, potatoes, and wine, of which last about one-half is exported. In minerals Aube is one of the poorest departments in France; a few iron mines have been worked, but with insignificant results. Chalk and clay are abundant; and there are also quarries of marble, lithographic stone, and building stone. The principal manufacture is hosiery; but the department also produces glass, earthenware, paper, sugar, and ropes, and has a large number of distilleries, tile-works, and dye-works, and an oil factory. Among the celebrated men connected with Aube are Villehardouin, Pope Urban IV., Mignard, Danton, Beugnot, and Ulbach. The capital is Troyes, and the arrondissements are Troyes, Arcis-sur-Aube, Nogent-sur-Seine, Bar-sur-Aube, and Bar-sur-Seine. Population in 1872, 255,687.

AUBENAS, a town of France, department of Ardèche, near the river of that name, 14 miles S.W. of Privas. It is beautifully situated on the slope of a hill, but its streets generally are crooked and narrow. It is surrounded by a ruinous wall flanked with towers, and has an old Gothic castle, now occupied by the municipal authorities. As the centre of the silk trade of the surrounding district, it is a place of considerable traffic, and there is besides a large local manufacture of silk and woollen goods. Population, 7694.

AUBER, DANIEL FRANÇOIS ESPRIT, musical composer, the chief representative of the French school, was the son of a Paris printseller. He was born at Caen, in Normandy, on the 29th January 1782, while his mother was on a visit to that town. Destined by his father to the pursuits of trade, he was allowed, nevertheless, to indulge his fondness for music, and learnt to play at an early age on several instruments, his first teacher being the Tyrolean composer, Ladurner. Sent at the age of twenty to London to complete his business training, he returned after the rupture of the peace of Amiens. He had already attempted musical composition, and at this period produced several *concertos pour basse*, in the manner of the violoncellist, Lamare, in whose name they were published. The praise given to his concerto for the violin, which was played at the Conservatoire by Mazas, encouraged him to undertake the resetting of the old comic opera, *Julie*. Conscious by this time of the need of regular study of his chosen art, he placed himself under the severe training of Cherubini, by which the special qualities of the young composer were admirably developed. In 1813 he made his *début* in an opera in one act, the *Séjour Militaire*, the unfavourable reception of which put an end for some years to his attempts as composer. But the failure in business and death of his father, in 1819, compelled him once more to turn to music, and to make that which had been his pastime the serious employment of his life. He produced another opera, the *Testament et les Billets-doux*, which was no better received than the former. But he persevered, and the next year was rewarded by the complete success

of his *Bergère Châtelaïne*, an opera in three acts. This was the first in a long series of brilliant successes, terminating only in the eighty-sixth year of his age. In 1822 began his long association with M. Scribe, who shared with him, as librettist, the success and growing popularity of his compositions. The opera of *Leicester*, in which they first worked together (1823), is remarkable also as showing the first evidences of the influence of Rossini on Auber's style. This style was, however, distinctly original, and was easily recognisable. A phrase of Auber, said his friend Théodore Gautier, is not the phrase of any one else. His characteristics are lightness and facility; sparkling vivacity, grace and elegance, clear and piquant melodiousness,—these marking him out as a true son of France, and making him her darling singer. Depth of thought, elevation of sentiment, intensity of passion, inspiration which grasps the sublime and the infinite—these are not in Auber.

Devoted by preference to the comic opera, as the most fitting field for his talents, he ventured on more than one occasion to pass into the field of grand opera, and in his *La Muette de Portici*, familiarly known as *Masaniello*, he achieved his greatest musical triumph. Produced at Paris in 1828, it rapidly became a European favourite, and its overture, songs, and choruses were everywhere heard. The duet, *Amour sacré de la patrie* was welcomed like a new *Marseillaise*; sung by Nourrit at Brussels in 1830, it became the signal for the revolution which broke out there. Among his other works, about fifty in all, the more important are—*Fra Diavolo* (1830), *Lestocq* (1834), *L'Ambassadrice* (1836), *Le Domino Noir* (1837), *Le Lac des Fées* (1839), *Les Diamants de la Couronne* (1841), *Haydée* (1847), *Marco Spada* (1853), and *La Fiancée du roi de Garbe* (1864). Official and other dignities testified the public appreciation of Auber's works. In 1829 he was elected member of the Institute, in 1830 he was named director of the court concerts, and in 1842 he succeeded Cherubini as director of the Conservatoire. He was also a member of the Legion of Honour from 1825, and attained the rank of commander in 1847. One of Auber's latest compositions was a march, written for the opening of the International Exhibition in London in 1862. His fascinating manners, his witty sayings, and his ever ready kindness and beneficence won for him a secure place in the respect and love of his fellow-citizens. He remained in his old home during the German siege of Paris, 1870-71, but the miseries of the Communist war which followed sickened his heart, and he at last refused to touch his beloved instrument, or to take food. He died May 13, 1871. (w.l.r.c.)

AUBIN, a town of France, in the department of Aveyron and arrondissement of Villefranche, principally remarkable for its extensive mines of coal, sulphur, and alum. It also carries on an active trade in sheep, iron goods, &c. A church of the 12th century, with some remarkable sculpture, and the ruins of the castle of the counts of Rouergue, are still in existence. Population, 8863.

The name Aubin, or St Aubin, is one of the most frequent in France, being borne by upwards of fifty villages from the Pyrenees to Jersey.

AUBURN, the capital of Cayuga county, in the state of New York, on the railway between Albany and Buffalo, 174 miles W. of the former. The irregularity of the surface on which the city is built has prevented the complete carrying out of the rectangular arrangement of streets, which is so much in favour in the United States, but the thoroughfares are wide and lined with trees, and the houses for the most part well built. The principal public buildings are in Genesee Street. The most remarkable of the institutions is the state prison, founded in 1816, which is conducted on the "silent system," and usually contains upwards of 1000 prisoners, who are employed each in

the work to which he has been trained. Auburn also possesses a Presbyterian theological seminary, founded in 1821, an academy, five public free schools, sixteen churches, an orphan asylum, two opera houses, and several newspaper offices. The water-power supplied by the outlet of the neighbouring lake of Owasco is utilised in a number of manufactories. Cotton and woollen goods, carpets, agricultural implements, and other tools, paper, flour, and beer are the principal products.

AUBUSSON, a town of France, situated in a picturesque valley on the banks of the Creuse, in the department to which that river gives its name. It is said to have owed its origin to a number of Saracens, who, having escaped from the battle in which their nation was defeated by Charles Martel, were enticed by the beauty and convenience of the spot to establish themselves permanently there. It has long been famous for its carpets and tapestry, the art of weaving which was probably derived from those Eastern settlers, and it also manufactures common cotton and woollen goods, leather, tobacco, &c. Population, 6625.

AUCH, the ancient *Climberium* or *Augusta Auscorum*, one of the most ancient cities of France, capital of the department of Gers. In Cæsar's time this was the chief town of the Ausci. In the 8th century it became the capital of Gascony; and when that district was divided into countships, was the capital of Armagnac. The site of the modern town does not exactly coincide with that of the ancient, being on the opposite (the left) bank of the river Gers. Auch was probably destroyed by the Saracens about 724 A.D., and was afterwards rebuilt in its present picturesque situation on the slope of a hill. On the opposite side of the river, and occupying the site of the ancient city, is a considerable suburb, which is connected with the town by a bridge; and communication between the lower and the upper town is afforded by long flights of steps. The streets, though narrow, are generally well built, and a fine promenade in the upper part of the town gives a magnificent view of the surrounding country. Auch is the seat of an archbishopric, which was founded in the 4th century, and gave, till the Revolution, the title of Primate of Aquitania to the holder of the see. It has tribunals of commerce and primary jurisdiction, a royal college, an agricultural society, a theological seminary, with a museum and an extensive library, a theatre, &c. The cathedral of St Mary, one of the most magnificent in France, was commenced in the reign of Charles VIII. (1489), and finished in that of Louis XV. It exhibits several styles of architecture, contains many elegant monuments, and is adorned with fine stained-glass windows and carved woodwork. The *préfecture*, formerly the archiepiscopal palace, is a vast and noble edifice. The principal manufactures are hats, various kinds of linen and cotton stuffs, leather, &c., and there is a considerable trade, especially in the brandies of Armagnac. Population in 1872, 13,087.

AUCHTERARDER, a town and parish of Scotland, county of Perth, 15 miles W.S.W. of Perth. The town consists of a single street about a mile in length. It was formerly a royal burgh, but is now disfranchised. Near it is an ancient castle, said to have been a hunting-seat of Malcolm Canmore. It was in connection with this parish that the ecclesiastical dispute arose which led to the Disruption in the Church of Scotland in 1843. Population of town in 1871, 2599.

AUCHTERMUCHTY, a royal burgh and parish of Scotland, county of Fife, 8 miles W.S.W. of Cupar. The town is irregularly built on an elevated site, and is divided by the Leverspool, a rapid streamlet which runs down its centre. The manufacture of linen is carried on. Population of burgh in 1871, 1082.

AUCKLAND, a province of New Zealand, consisting of the northern portion of North Island, and bounded for the most part on the S. by the 39th parallel of latitude. In the N.W. it runs out into a peninsula between 200 and 300 miles in length, with a very irregular coast-line, especially on the eastern side. The total area of the province is about 17,000,000 acres, of which nearly 11,275,000 are still in possession of the Maoris, who are, however, continually disposing of their claims to the Government. The surface of the province is of a very varied character, presenting wide and fertile plains, stretches of fern-heath and swamp, mountain ranges and isolated peaks, tracts of richly-wooded jungle, rocky plateaus, and districts of strange volcanic activity. All round the coast there are a large number of natural harbours, and the most of the interior is traversed by navigable streams. The principal river-system is that of the Waikato (or Rushing Water), which rises in the Taupo Lake, in the south of the province, forces its way through an extensive rocky table-land, flows onwards for about 35 miles through a rich but marshy basin, joins its waters with the Waipa (or Peaceful Water), its largest tributary, cuts a passage through the Taupiri range, and after traversing the fertile expanse of its lower basin, turns abruptly to the W. and falls into the sea about 35 miles S. of the city of Auckland. The value of the Waikato as a commercial highway is greatly lessened by its mouth being encumbered with sandbanks, that prevent the entrance of ships. To the E. of this river lies the valley of the Thames, fertile and well watered by several streams, and still further eastward extends the versant of the Bay of Plenty. The course of settlement has hitherto advanced for the most part along the valleys of the Waikato and the Thames,—Cambridge, about 10½ miles S. of the city of Auckland, being the frontier station in the former, and Tapapa, a little further to the S. in the latter. Nearly the whole of the N.W. peninsula is occupied by a scattered population, and various flourishing townships are situated along the coast on all sides. In 1873 there were 3842 holdings in the province, and about 225,000 acres had been broken up. Hitherto the cultivation of the cereals has not proved sufficiently remunerative, though climate and soil are equally favourable, and the attention of the farmer has principally been turned to the rearing of the various descriptions of live stock, more especially sheep. The natural wealth of the province consists principally in its gold and timber. Coal has been found in several districts, and a few mines have been successfully worked, as Kawakawa (at the Bay of Islands), Drury, and Whangarei; but the most important deposits are comparatively undisturbed. It is believed that iron may eventually be found in considerable quantities, and various minerals have been pointed out in the interior by scientific travellers. The chief seats of the gold-diggings are the Coromandel peninsula and the Thames valley. The quantity exported in 1871 was valued at £1,888,708. The most important timber tree is the kauri-pine, which is peculiar to Auckland, and does not grow further south than 37° 30'. It is of magnificent dimensions, and valuable, not only as the most extensively used building material, but on account of the fossil gum which is found wherever the kauri forest has been. This gum forms one of the chief articles of export, about 14,277 tons being the amount in the three years 1870, 1871, and 1872. There are various other trees of considerable value, such as the rimu, the kahikatea, and the totara. The timber trade, both domestic and foreign, is increasing in importance, and shipbuilding is extensively carried on. There are large districts overgrown with the *phormium* or New Zealand flax, and the right to cut it on the waste lands is granted by the Government at a low price. In 1873, 1497 tons

of the prepared fibre, valued at £27,783, were exported, besides a considerable quantity of manufactured rope. Those great necessities of commerce, roads and railways, are being constructed in various directions. A line is in course of formation from Auckland up the valley of the Waikato, as far as Newcastle, at the confluence of the Waipa, and a survey has been made for about 20 miles further. A road runs from Bowen, on the Bay of Plenty, across the country, through the wonderful lake district, with its boiling fountains, steam geysers, and mud-baths, round by the east coast of Taupo Lake, and over the highlands to Napier, in Hawke's Bay province. The history of Auckland was for long the history of New Zealand, and will be fully treated under that heading. (See *Nzw Zealand*.)

For a descriptive account of a large part of the province, the reader is referred to Dr Hochstetter's valuable works, especially to his *New Zealand*, 1863. A very graphic sketch of some of the natural curiosities is furnished by Anthony Trollope in his *Australia and New Zealand*, vol. ii.

AUCKLAND, the capital of the above province, is finely situated on an isthmus in the N.W. peninsula, on the S. shore of the Waitemata harbour, which is formed by an inlet of the Hauraki Gulf. Lat. 36° 51' S., long. 174° 50'. On the other side of the isthmus lies the harbour and town of Manukau, which serves as a supplementary port to the city. Auckland was founded in 1840 by Governor Hobson, and became a burgh in 1851. It was till 1865 the seat of the Government, which is now situated at Wellington. The city has a fine appearance, especially from the harbour, and is surrounded by a number of flourishing suburban villages, with several of which it is connected by railway. Among the public buildings in the city and neighbourhood may be mentioned the governor's house, the cathedral, St John's Episcopal college, about 4 miles distant, the Auckland college and grammar school, the Episcopal grammar school, in the suburb of Parnell, the provincial hospital, the provincial lunatic asylum, and the orphanage at Parnell. A wharf, 1690 feet in length, has been built opposite the centre of the city, and affords excellent accommodation for the gradually increasing traffic of the harbour. In 1872, 170 non-colonial vessels, with a tonnage of 54,257 tons, entered the port, besides a large number of coasting ships. There are registered at Auckland 167 sailing vessels and 20 steamships, most of them of provincial build. The population, which was 7989 in 1862, had increased by 1871 to 12,937 (with the suburbs to 18,000), and is now estimated at about 21,000.

AUCKLAND ISLANDS, a group discovered in 1806 by Captain Briscoe, of the English whaler "Ocean," about 180 miles S. of New Zealand, in lat. 50° 24', long. 166° 7' E. The islands, of volcanic origin, are very fertile, and are covered with forest. They were granted to the Messrs Enderby by the British Government as a whaling station, but the establishment was abandoned in 1852. (See *Royal's Auckland Islands*, 1874.)

AUCKLAND, WILLIAM EDEN, BARON, an eminent diplomatist and politician, third son of Sir Robert Eden, Bart., of West Auckland, was born in 1744. He was educated at Eton and Oxford, and adopted the profession of the law. At the age of twenty-seven he resigned his practice at the bar, and engaged in political life as under-secretary to Lord Suffolk. By the favour of the duke of Marlborough, he obtained a seat for Woodstock, and soon gave proof of his ability in the House. He attached himself to Lord North's party, and after serving under Lord Carlisle on the unsuccessful commission to the colonists in America, acted as secretary to that nobleman, when he held the post of viceroy in Ireland. During this time he had obtained the offices of director and auditor of Greenwich Hospital, which

probably yielded him an income sufficient for carrying on his political career. In 1783 he took a leading part in negotiating the remarkable coalition between North and Fox, and was rewarded by being made vice-treasurer of Ireland. In 1784 he opposed Pitt's proposal for commercial reciprocity with Ireland, but in so doing contrived to separate himself to some extent from his own party, and shortly after accepted from Pitt the office of plenipotentiary at Paris. Here he successfully negotiated the important commercial treaty with France; and after his appointment as ambassador to Spain, he rendered valuable service in settling the dispute between the British and French Governments with regard to the affairs of Holland. In 1789 he was made an Irish peer, with the title of Baron Auckland, and in 1793 he was raised to the British peerage as Baron Auckland, of West Auckland, Durham. For three years, 1798-1801, he held office as postmaster-general. He died suddenly in 1814. In 1776 he married the sister of the first earl of Minto, by whom he had a large family. Besides numerous pamphlets on political matters of the day, Lord Auckland wrote a treatise on the *Principles of the Penal Law*, 1771. His political conduct has been frequently censured; he was a skilful diplomatist, and as a statesman was specially remarkable for his clear grasp of economic principles. His *Journal and Correspondence*, 4 vols. 1860-1862, published by his son, the bishop of Bath and Wells, throws considerable light on the political history of his time.

AUCKLAND, GEORGE EDEN, EARL OF, Governor-General of India, born 20th August 1784, was the second son of the subject of the preceding notice. He completed his education at Oxford, and was admitted to the bar in 1809. His elder brother was drowned in the Thames in the following year; and in 1814, on the death of his father, he took his seat in the House of Lords as Baron Auckland. He supported the Reform party steadily by his vote, and in 1830 was made president of the Board of Trade and master of the Mint. In 1834 he held office for a few months as first lord of the Admiralty, and in 1835 he was appointed Governor-General of India. He proved himself to be a painstaking and laborious legislator, and devoted himself specially to the improvement of native schools, and the expansion of the commercial industry of the nation committed to his care. These useful labours were interrupted in 1838 by the hostile movements of the Persians, which excited the fears not only of the Anglo-Indian Government but of the home authorities. Lord Auckland resolved to enter upon a war in Afghanistan, and on the 1st October 1838, published at Simla his famous manifesto. The early operations were crowned with success, and the Governor-General received the title of Earl of Auckland. But reverses followed quickly, and in the ensuing campaigns the British troops suffered the most severe disasters. Lord Auckland had the double mortification of seeing his policy a complete failure, and of being superseded before his errors could be rectified. In the autumn of 1841 he was succeeded in office by Lord Ellenborough, and returned to England in the following year. In 1846 he was made first lord of the Admiralty, which office he held until his death, 1st January 1849. He died unmarried, and the earldom became extinct.

AUCTION, a mode of selling property by offering it to the highest bidder in a public competition. By 8 Vict. c. 15, the uniform duty of £10 per annum is imposed on every licence to carry on the business of auctioneer, but duties on sales by auction are abolished. It is the duty of an auctioneer to sell for the best price he can obtain, and his authority cannot be delegated to another unless by special permission of his employer. The auctioneer's name must be exhibited on some conspicuous place during the



sale under a penalty of £20. Sales by auction usually take place under certain conditions, which it is the duty of the auctioneer to read to the bidders before the sale begins. To complete a sale by auction there must be a *bidding* by, or on behalf of, a person capable of making a contract, and an *acceptance* thereof by the auctioneer, and until the bidding is accepted both vendor and bidder are free, and may retract if they choose. If due notice is given, an agent may be employed to bid on behalf of the seller, but the employment of several bidders is improper, and if the sale is declared to be *without reserve*, any bidding on the behalf of the seller will vitiate the sale. *Puffing*, it has been said, is illegal, even if there be only one puffer. On the other hand, any hindrance to a free sale, either by a bidder deterring competitors from offering against him, or by an engagement among the competitors to refrain from bidding, in order to keep down the price of the goods and then share the profit, is a fraud upon the vendor. Two persons, however, may agree not to bid against each other. Auctioneers are entitled by their licence to act as appraisers also.

AUDEUS, or AUDIUS, a reformer of the 4th century, by birth a Mesopotamian. He suffered much persecution from the Syrian clergy for his fearless censure of their irregular lives, and was expelled from the church. He was afterwards banished into Scythia, where he gained many followers and established the monastic system. He died there at an advanced age, about 370 A.D. The Audæans celebrated the feast of Easter on the same day as the Jewish Passover, and they were also charged with attributing to the Deity a human shape. They appear to have founded this opinion on Genesis i. 26.

AUDE, a southern department of France, forming part of the old province of Languedoc, bounded on the E. by the Mediterranean, N. by the departments of Hérault and Tarn, N.W. by Upper Garonne, W. by Ariège, and S. by that of Eastern Pyrenees. It lies between lat. 42° 40' and 34° 30' N., and is 80 miles in length from E. to W., and 60 miles in breadth from N. to S. Area, 2341 square miles. The department of Aude is traversed on its western boundary from S. to N. by a mountain range of medium height, which unites the Pyrenees with the Southern Cevennes; and its northern frontier is occupied by the Black Mountains, the most western part of the Cevennes chain. The Corbières, a branch of the Pyrenees, runs in a S.W. and N.E. direction along the southern district. The Aude, its principal river, has almost its entire course in the department. Its principal affluents on the left are the Fresquel, Orbial, Argent-Double, and Cesse; on the right, the Guette, Salse, and Orbieu. The canal of Languedoc, which unites the Atlantic with the Mediterranean, traverses the department from E. to W. The lowness of the coast causes a series of large lagunes, the chief of which are those of Bagas, Sigean, Narbonne, Palme, and Leucate. The climate is variable, and often sudden in its alterations. The wind from the N.W., known as the *Cers*, blows with great violence, and the sea breeze is often laden with pestilential effluvia from the lagunes. Various kinds of wild animals, as the chamois, bear, wild boar, wolf, fox, and badger, inhabit the mountains and forests; game of all kinds is plentiful; and the coast and lagunes abound in fish. Mines of iron, copper, lead, manganese, cobalt, and antimony exist in the department; and, besides the beautiful marbles of Cascastel and Caunes, there are quarries of lithographic stone, gypsum, limestone, and slate. The coal mines are for the most part abandoned. The mountains contain many mineral springs, both cold and thermal. The agriculture of the department is in a very flourishing condition. The meadows are extensive and well watered, and are pastured by numerous flocks and herds. The grain

produce, consisting mainly of wheat, oats, rye, and Indian corn, considerably exceeds the consumption, and the vineyards yield an abundant supply of both white and red wines. Olives and almonds are also extensively cultivated, and the honey of Aude is much esteemed. Besides important manufactures of woollen and cotton cloths, combs, jet ornaments, and caaks, there are paper-mills, distilleries, tanneries, and extensive iron and salt works. The chief town is Carcassonne, and the department is divided into the four arrondissements of Carcassonne, Limoux, Narbonne, and Castelnaudary. Population in 1872, 285,927.

AUDEBERT, JEAN BAPTISTE, a distinguished French naturalist and artist, was born at Rochefort in 1759. He studied painting and drawing at Paris, and gained considerable reputation as a miniature painter. In 1787 he was employed to make drawings of some objects in a natural history collection, and was also a contributor in the preparation of the plates for Olivier's *Histoire des Insectes*. He thus acquired a taste for the study of natural history, and devoted himself with great eagerness to the new pursuit. In 1800 appeared his first original work, *L'Histoire Naturelle des Singes, des Makis, et des Galéopitèques*, illustrated by 62 folio plates, drawn and engraved by himself. The colouring in these plates was unusually beautiful, and was laid on by a method devised by the author himself. Audebert died in 1800, but he had left complete materials for another great work, *Histoire des Colibris, des Oiseaux-Mouches, des Jacanaires, et des Promerops*, which was published in 1802. 200 copies were printed in folio, 100 in large quarto, and 15 were printed with the whole text in letters of gold. Another work, left unfinished, was also published after the author's death, *L'Histoire des Grimpeaux, et des Oiseaux de Paradis*. The last two works also appeared together in two volumes with the title *Oiseaux dorés ou à reflets métalliques*, 1802.

AUDITOR, a person appointed to examine the accounts kept by the financial officers of the Crown, public corporations, or private persons, and to certify as to their accuracy. The multifarious statutes regulating the audit of public accounts have been superseded by the 29 and 30 Vict. c. 39, which gives power to the Queen to appoint a "comptroller and auditor-general," with the requisite staff to examine and verify the accounts prepared by the different departments of the public service. In examining accounts of the appropriation of the several supply grants, the comptroller and auditor-general "shall ascertain first whether the payments which the account department has charged to the grant are supported by vouchers or proofs of payments; and second, whether the money expended has been applied to the purpose or purposes for which such grant was intended to provide." The Treasury may also submit certain other accounts to the audit of the comptroller-general. All public moneys payable to the Exchequer are to be paid to the "account of Her Majesty's Exchequer" at the Bank of England, and daily returns of such payments must be forwarded to the comptroller. Quarterly accounts of the income and charge of the consolidated fund are to be prepared and transmitted to the comptroller, who, in case of any deficiency in the consolidated fund, may certify to the bank to make advances. The accounts of local boards, poor-law unions, &c., must be passed in a similar manner by an official auditor. It is the duty of the auditor to disallow all illegal payments, and surcharge them upon the person making or authorising them; but such disallowances may be removed by *certiorari* into the Court of Queen's Bench, or an appeal may be made to the local Government Board. In municipal corporations two burgesses must be chosen annually as auditors of the accounts.

AUDOUIN, JEAN VICTOR, a distinguished French entomologist, was born at Paris, April 27, 1797. He began the study of law, but was diverted from it by his strong predilection for natural history, which subsequently led him to enter the medical profession. In 1824 he was appointed assistant to Latreille in the entomological chair at the Paris museum of natural history, and succeeded him in 1833. He established in 1824, in conjunction with Dumas and Adolphe Brongniart, the *Annales des Sciences Naturelles*, to which he made numerous valuable contributions, generally in co-operation with M. Milne-Edwards. The greater part of his other papers are contained in the *Transactions of the Entomological Society*, of which he was one of the founders, and for many years president. In 1838 he became a member of the Academy of Sciences. He died in 1841, more from the effects of mental than of bodily exhaustion. His principal work, *Histoire des Insectes nuisibles à la Vigne*, was continued after his death by Milne-Edwards and Blanchard, and published in 1842.

AUDRAN, the name of a family of French artists and engravers, who for several generations were distinguished in the same line. The first who devoted himself to the art of engraving was Claude Audran, born 1592, and the last was Benoit, Claude's great-grandson, who died in 1712. The two most distinguished members of the family are the following:—

AUDRAN, GÉRARD, or GIRARD, the most celebrated French engraver, was the third son of Claude Audran, and was born at Lyons in 1640. He was taught the first principles of design and engraving by his father; and, following the example of his brother, went to Paris to perfect himself in his art. He there, in 1666, engraved for Le Brun *Constantine's Battle with Maxentius*, his *Triumph*, and the *Stoning of Stephen*, which gave great satisfaction to the painter, and placed Audran in the very first rank of engravers at Paris. Next year he set out for Rome, where he resided three years, and engraved several fine plates. That great patron of the arts, M. Colbert, was so struck with the beauty of Audran's works, that he persuaded Louis XIV. to recall him to Paris. On his return he applied himself assiduously to engraving, and was appointed engraver to the king, from whom he received great encouragement. In the year 1681 he was admitted to the council of the Royal Academy. He died at Paris in 1703. His engravings of Le Brun's *Battles of Alexander* are regarded as the best of his numerous works. "He was," says the Abbé Fontenai, "the most celebrated engraver that ever existed in the historical line. We have several subjects, which he engraved from his own designs, that manifested as much taste as character and facility. But in the *Battles of Alexander* he surpassed even the expectations of Le Brun himself." Gérard published in 1683 a work entitled *Les proportions du corps humain mesurées sur les plus belles figures de l'antiquité*, which has been translated into English.

AUDRAN, JEAN, nephew of Gérard, was born at Lyons in 1667. After having received instructions from his father, he went to Paris to perfect himself in the art of engraving under his uncle, next to whom he was the most distinguished member of his family. At the age of twenty his genius began to display itself in a surprising manner; and his subsequent success was such, that in 1707 he obtained the title of engraver to the king, Louis XIV., who allowed him a pension, with apartments in the Gobelins; and the following year he was made a member of the Royal Academy. He was eighty years of age before he quitted the graver, and nearly ninety when he died. The best prints of this artist are those which appear not so pleasing to the eye at first sight. In these the etching constitutes a great part; and he has finished them in a bold, rough

style. The *Rape of the Sabines*, after Poussin, is considered his masterpiece.

AUDUBON, JOHN JAMES, a well-known naturalist, was born in 1781 in Louisiana, where his parents, who were French Protestants, had taken up their residence while it was still a Spanish colony. They afterwards settled in Pennsylvania. From his early years he had a passion for observing the habits and appearances of birds, and attempting delineations of them from nature. At the age of fifteen he was sent to Paris, and remained there about two years, when among other studies he took some lessons in the drawing-school of David. On returning to America his father established him in a plantation in Pennsylvania, and he soon after married. But nothing could damp his ardour for natural history. For fifteen years he annually explored the depths of the primeval forests of America in long and hazardous expeditions, far from his family and his home. In these excursions he acquired the facility of making those spirited drawings of birds that gives such value to his magnificent work, *The Birds of America*. At that period he had not dreamed of any publication of his labours; as he informs us, "it was not the desire of fame that prompted to those long exiles; it was simply the enjoyment of nature." He afterwards removed with his family to the village of Henderson on the banks of the Ohio, where he continued his researches in natural history for several years, and at length set out for Philadelphia with a portfolio containing 200 sheets filled with coloured delineations of about 1000 birds. Business obliged him to quit Philadelphia unexpectedly for some weeks, and he deposited his portfolio in the warehouse of a friend; but to his intense dismay and mortification he found, on his return, that these precious fruits of his wanderings and his labours had been totally destroyed by rats. The shock threw him into a fever of several weeks' duration, that well-nigh proved fatal. But his native energy returned with returning health; and he resumed his gun and his game-bag, his pencils and his drawing-book, and plunged again into the recesses of the backwoods. In about three years he had again filled his portfolio, and then rejoined his family, who had in the meantime gone to Louisiana. After a short sojourn there he set out for the Old World, to exhibit to the ornithologists of Europe the riches of America in that department of natural history.

In 1826 Audubon arrived at Liverpool, where the merits of his spirited delineations of American birds were immediately recognised. An exhibition of them to the public in the galleries of the Royal Institution of that town was so successful that it was repeated at Manchester and at Edinburgh, where they were no less admired. When he proposed to publish a work on the birds of America, several naturalists advised him to issue the work in large quarto, as the most useful size for the lovers of natural history, and the most likely to afford him a sufficient number of subscribers to remunerate his labours. At first he yielded to this advice, and acknowledged its soundness; but finally he decided that his work should eclipse every other ornithological publication. Every bird was to be delineated of the size of life, and to each species a whole page was to be devoted; consequently, the largest *elephant folio* paper was to receive the impressions. This necessarily increased the expense of the work so much as to put it beyond the reach of most scientific naturalists—which accounts for the small number of persons who, for a considerable time, could be reckoned among his supporters in the gigantic undertaking. The exceptionally high character of the work, however, gradually became known; and a sufficient number of subscribers was at length obtained in Great Britain and America, during the ten or twelve years that the work was going through the press, to indemnify him

for the great cost of the publication—leaving him, however, a very inadequate compensation for his extraordinary industry and skill. The first volume was published at New York in the end of the year 1830, the second in 1834, the third in 1837, and the fourth and last in 1839. The whole consists of 435 coloured plates, containing 1055 figures of birds the size of life. It is certainly the most magnificent work of the kind ever given to the world, and is well characterised by Cuvier, "C'est le plus magnifique monument que l'Art ait encore élevé à la Nature."

During the preparation and publication of his great work Audubon made several excursions from Great Britain. In the summer of 1828 he visited Paris, where he made the acquaintance of Cuvier, Humboldt, and other celebrated naturalists, and received from them every mark of honour and esteem. The following winter he passed in London. In April of 1830 he revisited the United States of America, and again explored the forests of the central and southern federal territories. In the following year he returned to London and Edinburgh, but the August of 1831 found him again in New York. The succeeding winter and spring he spent in Florida and South Carolina; and in the summer of 1832 he set out for the Northern States, with an intention of studying the annual migrations of birds, particularly of the passenger pigeon, of which he has given a striking description; but his career was arrested at Boston by a severe attack of cholera, which detained him there till the middle of August. After that he explored the coasts, lakes, rivers, and mountains of North America, from Labrador and Canada to Florida, during a series of laborious journeys, that occupied him for three years. From Charleston, accompanied by his wife and family, he took his third departure for Britain. During his earlier residence in Edinburgh he had begun to publish his *American Ornithological Biography*, which at length filled five large octavo volumes. The first was issued there by Adam Black in 1831; the last appeared in 1839. This book is admirable for the vivid pictures it presents of the habits of the birds, and the adventures of the naturalist. The descriptions are characteristically accurate and interesting.

In 1839 Audubon bade a final adieu to Europe; and returning to his native country, he published, in a more popular form, his *Birds of America*, in seven octavo volumes, the last of which appeared in 1844. His ardent love of nature still prompted him to new enterprises, and he set out on fresh excursions; but in these he was always accompanied by his two sons, and one or two other naturalists. The result of these excursions was the projection of a new work, *The Quadrupeds of America*, in atlas folio, and also a *Biography of American Quadrupeds*, both of which were commenced at Philadelphia in 1840. The latter was completed in 1850, and is, perhaps, even superior to his *Ornithological Biography*.

To great intelligence in observing, and accuracy in delineating nature, to a vigorous, handsome frame, and pleasing expressive features, Audubon united very estimable mental qualities, and a deep sense of religion without a trace of bigotry. His conversation was animated and instructive, his manner unassuming, and he always spoke with gratitude to Heaven for the very happy life he had been permitted to enjoy. He died, after a short illness, in his own residence on the banks of the Hudson, at New York, on the 27th of January 1851. See *Life and Adventures of J. J. Audubon the Naturalist*, edited, from materials supplied by his widow, by Robert Buchanan, London, 1868.

AUGELIAS (*Abylas*, *Abylas*, cf. *ἠλίου ἀβύσσος*), in *Greek Legend*, a son of Helios, the sun. He was a prince of Ælia, and, consistently with his being a descendant of the sun-god, had an immense wealth of herds, including twelve bulls sacred to Helios, and white as swans. He lived

beside the stream Menios (*Mῆνις* = moon); and his daughter Argemede was, like Medeia and Circe, skilled in witchcraft, and connected with the moon goddess. The task of Hercules was to clear out all his stalls in one day, and without help. This he did by making an opening in the wall and turning the stream through them. Augeias had promised him a tenth of the herd, but refused this, alleging that Hercules had acted only in the service of Eurystheus.

AUGEREAU, PIERRE FRANÇOIS CHARLES, Duke of Castiglione, was the son of obscure parents, and born in 1757. After serving for a short period in the armies of France, he entered the Neapolitan service, and for some time supported himself by teaching fencing at Naples. In 1792 he joined the Republican army that watched the movements of Spain. He rose rapidly to the rank of brigadier-general, and commanded a division in the army of Italy. Here he distinguished himself in numerous engagements by his energy, skill, and vigorous rapidity of action. To him were due in great measure the brilliant victories of Millesimo, Dego, and Castiglione, and he led the decisive charges at the bloody combats of Lodi and Arcola. In 1797 he took part with Barras and the Directory, and was an active agent in the revolution of the 18th of Fructidor; but his jealousy of his former comrade, Bonaparte, prevented their intimacy; and he was one of the general officers not privy to the noted revolution of the 18th of Brumaire (Nov. 9) 1799. He received, however, the command of the army of Holland and the Lower Rhine, but was superseded in 1801. From that time he lived in retirement, till 1804, when he was made a marshal of the French empire, and in the following year he was appointed to the command of the expedition against the Vorarlberg, which he quickly subdued. He also distinguished himself greatly in the battles of Jena and Eylau. In 1809–10 he commanded the French in Catalonia, and tarnished his laurels by his great cruelty to the Spaniards; but he was again more honourably conspicuous in the campaign of 1813, especially in the terrible battle of Leipsic. In 1814 he had the command of a reserve army at Lyons, and might have made a diversion in favour of Napoleon, but he preferred to submit, and retained a command under the Bourbons. In the following year he at first refused to join Napoleon on his escape from Elba, and when he would afterwards have accepted a command his services were declined. He also failed to obtain military office under the new dynasty, and after having had the painful task of being one of the commission on the trial of Ney, he returned to his estates, where he died of dropsy in 1816.

AUGSBURG, a celebrated city of Germany, capital of the circle of Swabia and Neuburg in Bavaria, the principal seat of the commerce of South Germany, and of commercial transactions with the south of Europe. It derives its name from the Roman Emperor Augustus, who, on the conquest of Rætia by Drusus, established a Roman colony named *Augusta Vindelicorum* (about 14 a.c.) In the 5th century it was sacked by the Huns, and afterwards came under the power of the Frankish kings. It was almost entirely destroyed in the war of Charlemagne against Thassilon, duke of Bavaria; and after the dissolution and division of that empire, it fell into the hands of the dukes of Swabia. After this it rose rapidly into importance as a manufacturing and commercial town, and its merchant princes, the Fuggers and Welsers, rivalled the Medici of Florence; but the alterations produced in the currents of trade by the discoveries of the 15th and 16th centuries occasioned a great decline. In 1276 it was raised to the rank of a free imperial city, which it retained, with many changes in its internal constitution, till 1806, when it was annexed to the kingdom of Bavaria. Meanwhile, it was

the scene of numerous events of historical importance. It was besieged and taken by Gustavus Adolphus in 1632, and in 1635 it surrendered to the imperial forces; in 1703 it was bombarded by the electoral prince of Bavaria, and forced to pay a contribution of 400,000 dollars; and in

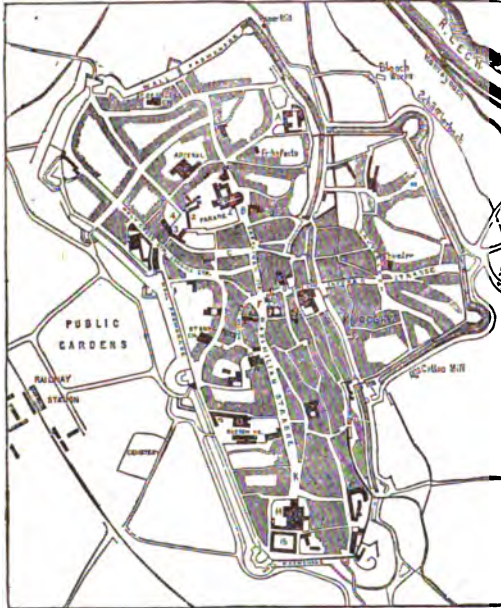

Sketch Plan of Augsburg.

- A. St Stephen's Platz.
- B. Ceyloner Platz.
- C. Fruit Market.
- D. Metzger Platz.
- E. Perlschuhren.
- F. Ludwig's Platz.
- G. Fish Market.
- H. Horse Market.
- J. St Anna Platz.

- K. Maximilian's Platz
- 1. Cathedral.
- 2. Frohnhof.
- 3. Palace.
- 4. Court Garden.
- 5. Barefoot Church.
- 6. Shambles.
- 7. Town-Hall.
- 8. Exchange (Börse).

- 9. Police.
- 10. Firehouse.
- 11. St Moritz Church.
- 12. St Katherine's Nun-  
nery.
- 13. St Ulrich's Church.
- 14. Military Stables.
- 15. Holy Ghost Hospital.

the war of 1803 it suffered severely. Of its conventions the most memorable are those which gave birth to the Augsburg confession (1530) and to the Augsburg alliance (1686).

The city is pleasantly situated in an extensive and fertile plain, between the rivers Wertach and Lech, 36 miles W.N.W. of Munich, lat. 48° 21' 44" N., long. 10° 54' 42" E. Its fortifications were dismantled in 1703, and have since been converted into public promenades. Maximilian Street is remarkable for its breadth and architectural magnificence. One of its most interesting edifices is the Fugger House, of which the entire front is painted in fresco. Among the public buildings of Augsburg most worthy of notice is the town-hall, said to be one of the finest in Germany, built by Elias Holl in 1616-20. One of its rooms, called the "Golden Hall," from the profusion of its gilding, is 113 feet long, 59 broad, and 53 high. The palace of the bishops, where the memorable Confession of Faith was presented to Charles V., is now used for Government offices. The cathedral dates in its oldest portions from the 10th century. There are also various churches and chapels, a school of arts, a polytechnic institution, a picture gallery in the former monastery of St Catherine, a museum, observatory, botanical gardens, an exchange, gymnasium, deaf-mute institution, orphan asylum, public library, several remarkable fountains dating from the 16th century, &c. The "Fuggerei," built in 1519 by the brothers Fugger, consists of 106 small houses, let to indigent Roman Catholic citizens at a merely nominal

rent. The manufactures of Augsburg are various and important, consisting of woollen, linen, cotton, and silk goods, watches, jewellery, and goldsmith-work, mathematical instruments, machinery, leather, paper, chemical stuffs, types, &c. Copper-engraving, for which it was formerly noted, is no longer carried on; but printing, lithography, and publishing have acquired a considerable development, one of the best-known Continental newspapers being the *Allgemeine Zeitung* or *Augsburg Gazette*. Augsburg is an important railway junction. On the opposite side of the river, which is here crossed by a bridge, lies the little village of Lechhausen. Population in 1871, 51,270.

#### AUGSBURG CONFESSION. See CREEDS.

**AUGURS**, in *Roman Antiquities*, a college or board appointed to interpret, according to the books (*libri augurales*) in which the science of divination was laid down, the *auspicia* or signs of approval or disapproval sent by Jupiter on the occasion of any public transaction. At first, it is said, there were only two augurs, one from each of the tribes Ramnes and Titias. Two more were added by Numa, and again other two for the third tribe of Luceres, that is six altogether. But in the year 300 B.C. it is certain that there were only four, to which number five plebeian places were added by the *lex Ogulnia*. Sulla increased the number to fifteen, at which it continued, with the exception that Cæsar appointed a sixteenth, and the emperors frequently added as *supra numerum* persons of distinction, or of their own family. An augur retained his office and sacred character for life. The college had the right of election of new members. The insignia of their office were the *lituus*, or crook, and the dress called *trabea*. The natural region to look to for signs of the will of Jupiter was the sky, where lightning and the flight of birds seemed directed by him as counsel to men. The latter, however, was the more difficult of interpretation, and upon it, therefore, mainly hinged the system of divination with which the augurs were occupied, and which is expressed in the terms *augurium* and *auspicium* (*aves ferere, aves spicere*). The presence of augurs was required only in observing signs in the sky, where their first duty was to mark out with the *lituus* a space or *templum* in the sky within which the omen must occur. Such observations being properly made only in the city of Rome, augurs are not found elsewhere. Signs of the will of the gods were of two kinds, either in answer to a request (*auspicia impetrativa*), or incidental (*auspicia oblativa*). Of such signs there were five classes:—(1.) *Signs in the sky* (*coelestia auspicia*), consisting chiefly of thunder and lightning, but not excluding falling stars and other phenomena. Lightning from left to right was favourable, from right to left unfavourable; and this being a very direct and impressive token of the will of Jupiter, the observation of it was held to apply to all public transactions fixed for the day on which it occurred. Whether favourable or the reverse in its direction, the appearance of lightning was held as a voice of the god against business being done in the public assemblies. But since the person charged to take the auspices (*de celo servasse*) for a certain day was constitutionally subject to no other authority who could test the truth or falsehood of his statement that he had observed lightning, it happened that this became a favourite means of putting off meetings of the public assembly. Restrictions were, however, imposed on it in the later times of the republic. When a new consul, prætor, or quaestor entered on his first day of office and prayed the gods for good omens, it was a matter of custom to report to him that lightning from the left had been seen. (2.) *Signs from birds* (*signa ex avibus*), with reference to the direction of their flight, and also to their singing, or uttering other

sounds. In matters of ordinary life on which divine counsel was prayed for, it was usual to have recourse to this form of divination. For public affairs it was, by the time of Cicero, superseded by the fictitious observation of lightning. (3.) *Feeding of birds (auspicia ex tripudiis)*, which consisted in observing whether a bird,—usually a fowl,—on grain being thrown before it, let fall a particle from its mouth (*tripudium solistimum*). If it did so, the will of the gods was in favour of the enterprise in question. The simplicity of this ceremony recommended it for very general use, particularly in the army when on service. The fowls were kept in cages by a servant, styled *pullarius*. In imperial times are mentioned the *decurias pullarii*. (4.) *Signs from animals (pedestria auspicia, or ex quadrupedibus)*, i.e., observation of the course of, or sounds uttered by, quadrupeds and serpents within a fixed space, corresponding to the observations of the flight of birds, but much less frequently employed. It had gone out of use by the time of Cicero. (5.) *Warnings (signa ex diris)*, consisting of all unusual phenomena, but chiefly such as boded ill. Being accidental in their occurrence, they belonged to the *auguria oblativa*, and their interpretation was not a matter for the augurs, unless occurring in the course of some public transaction, in which case they formed a divine veto against it. Otherwise, reference was made for an interpretation to the Pontifices in olden times, afterwards frequently to the Sibylline books, or the Etruscan haruspices, when the incident was not already provided for by a rule, as, for example, that it was unlucky for a person leaving his house to meet a raven, that the sudden death of a person from epilepsy at a public meeting was a sign to break up the assembly, not to mention other instances of adverse omens. A Roman, however, did not necessarily regard a warning as binding unless it was clearly apprehended. Not only could an accidental oversight render it useless, but to some extent measures could be taken to prevent any warning being noticed. At sacrifices, for instance, the flute was played *ne quid aliud exaudiat* (Pliny, *Nat. Hist.*, xviii. 2, 11).

Among the other means of discovering the will of the gods were casting lots, oracles of Apollo (in the hands of the college *saceris faciuntis*), but chiefly the examination of the entrails of animals slain for sacrifice. Anything abnormal found there was brought under the notice of the augurs as warnings, but usually the Etruscan haruspices were employed for this. The persons entitled to ask for an expression of the divine will on a public affair were the magistrates. To the highest offices, including all persons of consular and prætorian rank, belonged the right of taking *auspicia maxima*; to the inferior offices of ædile and quaestor, the *auspicia minora*; the differences between these, however, must have been small. The subjects for which *auspicia publica* were always taken were the election of magistrates, their entering on office, the holding of a public assembly to pass decrees, the setting out of an army for war. They could only be taken in Rome itself; and in case of a commander having to renew his *auspicia*, he must either return to Rome or select a spot in the foreign country to represent the hearth of that city. The time for observing auspices was, as a rule, between midnight and dawn of the day for which the transaction was fixed about which they were desired. But whether it was so ordered in the ritual, or whether this was to leave the whole day free, is not known. In military affairs this course was not always possible, as in the case of taking auspices before crossing a river. The founding of colonies, the beginning of a battle, before calling together an army, before sittings of the senate, at decisions of peace or war, were occasions, not always but frequently, for taking auspices. The place where the ceremony was performed was not fixed but

varied, so as to have a close relation to the object to which it referred. A spot being selected, the official charged to make the observation (*specio*) pitched his tent there some days before. A matter postponed through adverse signs from the gods could on the following or some future day be again brought forward for the auspices (*respetere auspicia*). If an error (*vitium*) occurred in the auspices, the augurs could, of their own accord or at the request of the senate, inform themselves of the circumstances, and decree upon it. A consul could refuse to accept their decree while he remained in office, but on retiring he could be prosecuted. *Auspicia oblativa* referred mostly to the comitia. A magistrate was not bound to take notice of signs reported merely by a private person, but he could not overlook such a report from a brother magistrate. For example, if a quaestor on his entry to office observed lightning and announced it to the consul, the latter must delay the public assembly for the day. (A. S. M.)

AUGUST, originally *Septilis*, as being the sixth month in the pre-Julian Roman year, received its present name from the Emperor Augustus. The preceding month, *Quintilis*, had been called July after the great Julius Cæsar, and the senate thought to propitiate the emperor by conferring a similar honour upon him. August was selected, not as being the natal month of Augustus, but because in it his greatest good fortune had happened to him. In that month he had been admitted to the consulate, had thrice celebrated a triumph, had received the allegiance of the soldiers stationed on the Janiculum, had concluded the civil war, and had subdued Egypt. As July contained thirty-one days, and August only thirty, it was thought necessary to add another day to the latter month, in order that Augustus might not be in any respect inferior to Julius.

AUGUSTA, the capital of the State of Maine, and seat of justice, is situated on the Kennebec River (in Kennebec county), 43 miles from its mouth, in lat. 44° 19' N., long. 69° 50' W. The city lies mainly on the right bank of the Kennebec River, which is here crossed by a bridge 520 feet long. The business portion of the city was destroyed by fire in 1865, but has since been rebuilt. Its principal public buildings are the State house, State insane asylum, and United States' arsenal. It has several banks, daily and weekly newspapers, and numerous churches. The population of Augusta, by the census of 1870, was 7808.

AUGUSTA, a city of Georgia, in the United States of America, the capital of the county of Richmond. It is situated in a beautiful plain, on the Savannah River, 231 miles from its mouth, and has extensive railway communication. Like other American cities it is spacious and regular in its plan, Greene Street, for example, being 168 feet in width, with a row of trees extending along each side. The principal buildings are the city hall, a masonic hall, an oddfellows' hall, the Richmond academy, the Georgia medical college, the opera-house, and an orphan asylum. Besides these, the city possesses an arsenal, water-works, a number of banks, newspaper offices, extensive cotton factories and flour mills, several foundries, two tobacco factories, &c. Water-power is abundantly supplied from the river by the Augusta canal, which was constructed in 1845. Augusta was an important place during the revolutionary war, and continued to flourish amazingly till the opening of the Georgia railway. A temporary decline then took place, owing to the change in the methods of traffic; but a new current of prosperity speedily set in, which still continues. Population in 1870, 15,386.

AUGUSTAN HISTORY is the title bestowed upon a collection of the biographies of the Roman emperors, from Hadrian to Carinus, written under Diocletian and Constantine.

tine, and usually regarded as the composition of six authors,—Ælius Spartianus, Julius Capitolinus, Ælius Lampridius, Vulcatius Gallicanus, Trebellius Pollio, and Flavius Vopiscus. Upon investigation, however, there appears good reason for reducing these writers to four. The distribution of the respective biographies among them, according to the arrangement of the MSS., is supported by no extraneous authority, and depends upon no intelligible principle. Without entering into detail, for which space fails us, it must suffice to state that up to and including the biography of Alexander Severus, the authorship of the various memoirs is interchanged among Spartianus, Lampridius, and Capitolinus, in a manner only explicable upon the hypothesis of a division of labour among these writers, or on that of their having selected their subjects entirely at random. The latter is contradicted by their own affirmations, and no trace of any mutual concert is discoverable, neither is there any perceptible difference of style. When, therefore, we find the excerpts in the Palatine MS. assigning all the biographies preceding that of Maximin to Spartianus alone, and remark that his prænomen and that of Lampridius are alike given as Ælius, we cannot avoid suspecting with Casaubon and Salmasius that the full name was Ælius Lampridius Spartianus, and that two authors have been manufactured out of one. We further find Spartianus observing, at the commencement of his life of Ælius Verus, that having written the lives of all the emperors who had borne the title of Augustus from Julius Cæsar down to Hadrian, he purposes from that point to comprise the Cæsars also. This excludes the idea of his having written without a plan, or in concert with any colleague. His biographies are regularly dedicated to Diocletian down to that of Pescennius Niger, after which, with one exception, probably due to the corruption of the MSS., they are inscribed to Constantine, as would naturally be the case with a work continued under this prince's reign after having been commenced under his predecessor's. We may also with probability ascribe to Spartianus the life of Avidius Cassius, attributed in the MSS. to Vulcatius Gallicanus, but whose author describes his undertaking in terms almost identical with those employed by Spartianus. No biography subsequent to that of Alexander Severus is attributed to Spartianus by any MS., and the next series, comprising the Maximins, the Gordians, and Maximus and Balbinus, is undoubtedly the production of Julius Capitolinus, who addresses his work to Constantine, and professedly proceeds, in some respects, upon a different plan from his predecessor. The work of Spartianus must have remained incomplete, and Capitolinus must have proposed to fill up the interval between him and Trebellius Pollio, who dedicates his life of Claudius Gothicus to Constantius Chlorus, and whom we know, from the testimony of Vopiscus, to have written the lives of the Philippi and their successors up to Claudius, some years before 303 A.D. In that year (and not 291 A.D., as supposed by Salmasius and Clinton) Vopiscus was solicited by the urban prefect, Junius Tiberianus, to undertake the life of Aurelian; this biography appears from internal evidence to have been published by 307 A.D., and the lives of Aurelian's successors down to Carinus were added before the death of Diocletian in 313. We may therefore reduce the Augustan historians from six to four, and assign their respective shares as follows: To Spartianus, the biographies from Julius Cæsar to Alexander Severus, all anterior to Hadrian being lost; to Capitolinus, those from Maximin to the younger Gordian; to Trebellius Pollio, the lives of Valerian, Gallienus, the "Thirty Tyrants," and Claudius Gothicus, those of the Philippi, the Decii, Gallus, Æmilianus, and part of Valerian's being lost; to Vopiscus, the remainder, from Aurelian to Carinus. Some difficulty is created by the mention of

Capitolinus, the latest biographer in order of composition, by his predecessor Vopiscus, but the passage may be an interpolation, or may refer to some other work.

The importance of the Augustan history as a repertory of information is very considerable, but its literary pretensions are of the humblest order. The writers' standard was confessedly low. "My purpose," says Vopiscus, "has been to provide materials for more eloquent persons than myself." Considering the perverted taste of the age, it is perhaps fortunate that the task fell into the hands of no showy declaimer, who measured his success by his skill in making surface do duty for substance, but of homely, matter-of-fact scribes, whose sole concern was to record what they knew. Their narrative is most unmethodical and inartificial; their style is tame and plebeian; their conception of biography is that of a collection of anecdotes; they have no notion of arrangement, no measure of proportion, and no criterion of discrimination between the important and the trivial; they are equally destitute of critical and of historical insight, unable to sift the authorities on which they rely, and unsuspecting of the stupendous social revolution comprised within the period which they undertake to describe. Their value, consequently, depends very much on that of the sources to which they happen to have recourse for any given period of history, and on the fidelity of their adherence to these when valuable. Marius Maximus and Junius Cordus, to whose qualifications they themselves bear no favourable testimony, were their chief authorities for the earlier lives of the series. For the later they have been obliged to resort more largely to public records, and have thus preserved matter of the highest importance, rescuing from oblivion many imperial rescripts and senatorian decrees, reports of official proceedings and speeches on public occasions, and a number of interesting and characteristic letters from various emperors. Their incidental allusions sometimes cast vivid though undesigned light on the circumstances of the age, and they have made large contributions to our knowledge of imperial jurisprudence in particular. Even their trivialities have their use; their endless anecdotes respecting the personal habits of the subjects of their biographies, if valueless to the historian, are most acceptable to the archaeologist, and not unimportant to the economist and moralist. Their errors and deficiencies may in part be ascribed to the contemporary neglect of history as a branch of instruction. Education was in the hands of rhetoricians and grammarians; historians were read for their style, not for their matter, and since the days of Tacitus, none had arisen worth a schoolmaster's notice. We thus find Vopiscus acknowledging that when he began to write the life of Aurelian, he was entirely misinformed respecting the latter's competitor Firmus, and implying that he would not have ventured on Aurelian himself if he had not had access to the MS. of the emperor's own diary in the Ulpian library. The writers' historical estimates are superficial and conventional, but report the verdict of public opinion with substantial accuracy. The only imputation on the integrity of any of them lies against Trebellius Pollio, who, addressing his work to a descendant of Claudius, the successor and probably the assassin of Gallienus, has dwelt upon the latter versatile sovereign's carelessness and extravagance without acknowledgment of the elastic though fitful energy he so frequently displayed in defence of the empire. The caution of Vopiscus's references to Diocletian cannot be made a reproach to him.

No biographical particulars are recorded respecting any of these writers. From their acquaintance with Latin and Greek literature they must have been men of letters by profession, and very probably secretaries or librarians to persons of distinction. They appear particularly versed in

law. Spartianus's reference to himself as "Diocletian's own" seems to indicate that he was a domestic in the imperial household. They address their patrons with deference, acknowledging their own deficiencies, and seem painfully conscious of the profession of literature having fallen upon evil days.

The first edition of the *Augustan History* was printed at Milan in 1475, by Bonus Accursius, along with Suetonius. Being based upon the best MSS. it is superior to any of its successors until Casanbon's (1608). Casanbon manifested great critical ability in his notes, but for want of a good MS. left the restoration of the text to Balmastius (1620), whose notes are a most remarkable monument of erudition combined with acuteness in verbal criticism and general vigour of intellect. Little has since been done for the improvement of the text, which is still in a very unsatisfactory state. The most accurate edition is that by Jordan and Kysenhardt (Berlin, 1863), grounded on a collation of the Bamberg MS. with the Palatine (now the Vatican) used by Balmastius. The most important separate dissertations on the Augustan historians are that on the sixth volume of Heine's *Opuscula Philologica*; Broek's essay on the first four of them (Königsberg, 1869); Dirksen's elucidation of their references to Roman jurisprudence (Leipzig, 1849); Peter's critical emendations (Posen, 1868); Brunner's monograph on Vopiscus in the second volume of Büdinger's *Untersuchungen zur Römischen Kaiser-geschichte*, and J. Müller's disquisition in the third (Leipzig, 1868-69). There is no English translation. (R. G.)

**AUGUSTI, JOHN CHRISTIAN WILLIAM**, a distinguished German theologian, was born at Eschenberga, near Gotha, in 1772. He was of Jewish descent, his grandfather having been a rabbi who had been converted to the Christian faith. His early education he received partly from Moller, pastor of Gierstädt, who introduced him to the study of Hebrew, and partly at the gymnasium at Gotha. He then proceeded to the university of Jena, and completed his studies there in 1793. In 1798 he obtained a post as privat-docent, or university lecturer on philosophy, and began to turn his attention chiefly to Oriental subjects. In 1800 he was made professor extraordinary of philosophy, and three years after was appointed to the chair of Oriental languages. In 1808 he received the degree of doctor of theology, and in 1812 accepted a call to the chair of theology at the recently renovated university of Breslau. During the troubled years 1813 and 1814 he acted as rector, and received great praise for his firm and judicious conduct. In 1819 he was transferred to the university of Bonn, and in 1828 he united with his professorship the office of director of the consistory. He died at Coblenz in 1841. Augusti had little sympathy with the modern philosophical interpretations of dogma, and although he took up a position of free criticism with regard to the Biblical narratives, he yet held fast to the traditional faith. His works on theology (*History of Dogma*, 1805, and *System of Dogmatics*, 1809) are simple statements of fact, and do not attempt a speculative treatment of their subjects. In addition to several exegetical works, his most important writings are the *Denkwürdigkeiten aus der Christlichen Archæologie*, 12 vols., 1817-31, a partially digested mass of materials, and the *Handbuch der Christ. Archæologie*, 3 vols., 1836-7, which gives the substance of the larger work in a more compact and systematic form.

**AUGUSTINE (AURELIUS AUGUSTINUS)**, one of the four great fathers of the Latin Church, and admittedly the greatest of the four, more profound than Ambrose, his spiritual father, more original and systematic than Jerome, his contemporary and correspondent, and intellectually far more distinguished than Gregory the Great, the last of the series. The theological position and influence of Augustine may be said to be unrivalled. No single name has ever exercised such power over the Christian church, and no one mind ever made such an impression upon Christian thought.

Aurelius Augustinus was born at Tagaste (Tajelt), a town of Numidia, on the 13th of November 354 A.D. His father, Patricius, was a bourgeois of this town, and was still a

pagan at the time of his son's birth. His mother, Monica, was not only a Christian, but a woman of the most elevated, tender, and devoted piety, whose patient prayerfulness for both her husband and son (at length crowned with success in both cases), and whose affectionate and beautiful enthusiasm, have passed into a touching type of womanly saintliness for all ages. She early instructed her son in the faith and love of Jesus Christ, and for a time her instruction seems to have impressed his youthful mind. Falling ill he wished to be baptised; but when the danger was past, the rite was deferred, and, notwithstanding all his mother's admonitions and prayers, he grew up without any profession of Christian piety, or any devotion to Christian principles. Inheriting from his father a vehement and sensual disposition, he early gave way to the unbridled impulses of passion, and while still a mere youth, formed a connection, common enough at the time, but at variance with the principles of Christian morality. As the result of the connection he became the father of a son, whom he named Adeodatus in a fit of pious emotion, and to whom he was passionately attached.

In the midst of all his youthful pleasures Augustine was an earnest student. His father, observing the early development of his talents, formed the ambition of training him to the brilliant and lucrative career of a rhetorician, and he seems to have spared no expense to equip him for this career. The youth studied not only at his native town, but at Madaura and Carthage, and especially devoted himself to the Latin poets—many traces of his love for which are to be found in his writings. His acquaintance with Greek literature was much more limited, and, indeed, it has been doubted whether he could use, in the original, either the Hebrew or Greek Scriptures.<sup>1</sup> Apparently, he was in the habit of using translations of Plato (*Confess.*, viii. 2), but, on the other hand, Greek words frequently occur in his writings correctly rendered and discriminated; and he speaks in one of his epistles to Marcellinus (LIX. tom. ii. 294) of referring to the Greek Psalter and finding, in reference to certain difficulties, that it agreed with the Vulgate. Clausen, who has particularly investigated the point, sums up the evidence to the effect that Augustine was "fairly instructed in Greek grammar, and a subtle distinguisher of words," but that beyond this his knowledge was insufficient for a thorough comprehension of Greek books, and especially for those in the Hellenistic dialect.

While a student at Carthage he was particularly attracted by the theatre, the spectacles at which were of unusual magnificence. To his enthusiastic and sensuous spirit they were irresistible, and the extent to which he seems to have yielded to the fascination is sufficient proof of his active alienation from Christianity at this period. The Christian church, as it has been said, "abhorred the pagan theatre. The idolatrous rites, the lascivious attitudes, the gladiatorial shows, which were its inseparable accompaniments, were equally opposed to the dogmatic monotheism, to the piety, and to the mercy of the gospel." One of the most significant signs of a man having become a Christian was his habitual absence from the theatre. No one was more emphatic on this point afterwards than Augustine himself, and as the result of his own experience, he seems to have doubted, apart from the gross immoralities of the pagan stage, whether the indulgence in fictitious joys and woes is a warrantable excitement (*Confess.*, iii. 2).

Cicero's *Hortensius*, which he read in his nineteenth year, first awakened in Augustine's mind the spirit of specula-

<sup>1</sup> "Augustinus eruditus, ut ait, Ebrææ ac Græcæ linguæ ignarus." (Walsh, *B.M. Patrist.*, p. 352.) "Imperitus non tantum Hebræicæ sed etiam Græcæ linguæ, ipse fontes adire non potuit, sed solum fere translationem Latinam explicare conatus est."—(Rossmüller, *Hist. Jeterpret.*, II. 40.)

tion. He engaged restlessly in philosophical studies, and passed from one phase of thought to another, unable to find satisfaction in any. Manichæism first enthralled him. Its doctrine of two principles, one of good and one of evil, seemed to answer to the wild confusion of his own heart, and the conflict of higher and lower impulses which raged within him. It seemed to solve the mysteries which perplexed him in his own experience and in the world. He became a member of the sect, and entered into the class of *auditores*. His ambition was to be received among the number of the *Elect*, and so get to the heart of what he believed to be their higher knowledge. But falling in with Faustus, a distinguished Manichæan bishop and disputant, and entering into discussion with him, he was greatly disappointed. The system lost its attraction for him; he gradually became disgusted, and abandoned it. But before this he had left Carthage, shocked with the licence of the students, and had betaken himself for a time to Rome in the pursuit of his profession. There he also soon became dissatisfied, and accepted an invitation to proceed to Milan, where the people were in search of a teacher of rhetoric. He travelled thither at the public expense, and was welcomed by friends who already seem to have recognised his distinction (*Confess.*, i. 16).

At Milan the conflict of his mind in search of truth still continued. He was now in his thirtieth year, and for eleven years he had been seeking for mental rest, unable to find it. "To-morrow," he said to himself, "I shall find it: it will appear manifestly, and I shall grasp it" (*Confess.*, vi. 18). But it still eluded his grasp, and he sunk back again into despondency. The way, however, was being prepared for his conversion. Ambrose was bishop of Milan, and, although he had a weak voice, was noted for his eloquence. Augustine was attracted by his reputation, and went to hear the famous Christian preacher in order, as he himself relates (*Confess.*, v. 23), "to see whether his eloquence answered what was reported of it. I hung on his words attentively," he adds, "but of the matter I was but an unconcerned and contemptuous hearer." He confesses his delight so far: "The bishop's eloquence was more full of knowledge, yet in manner less pleasurable and soothing, than that of Faustus." He wished an opportunity of conversation with him, but this was not easily found. Ambrose had no leisure for philosophic discussion. He was accessible to all who sought him, but never for a moment free from study or the cares of duty. "Augustine used to enter, as all persons might, without being announced; but after staying for a while, afraid of interrupting him, he departed again." He continued, however, to hear Ambrose preach, and gradually the gospel of divine truth and grace was received into his heart. First Plato and then St Paul opened his mind to higher thoughts, and at length certain words of the latter were driven home with irresistible force to his conscience. He was busy with his friend Alypius in studying the Pauline epistles. His struggle of mind became intolerable; the thought of divine purity fighting in his heart with the love of the world and of the flesh. He burst into an uncontrollable flood of tears and rushed out into his garden, flinging himself under a fig tree that he might allow his tears to have full vent, and pour out his heart to God. Suddenly he seemed to hear a voice calling upon him to consult the divine oracle, "Take up and read, take up and read." He left off weeping, rose up, and sought the volume where Alypius was sitting, and opening it read in silence the following passage: "Not in rioting and drunkenness, not in chambering and wantonness, not in strife and envying. But put ye on the Lord Jesus Christ, and make not provision for the flesh to fulfil the lusts thereof" (Rom. xiii. 13, 14). He adds, "I had neither desire nor need to

read farther. As I finished the sentence, as though the light of peace had been poured into my heart, all the shadows of doubt dispersed. Thus hast Thou converted me to Thee, so as no longer to seek either for wife or other hope of the world, standing fast in that rule of faith in which Thou so many years before hadst revealed me to my mother" (*Confess.*, viii. 30).

After his conversion, which is supposed to have occurred in the summer of 386, Augustine gave up his profession as a teacher of rhetoric, and retired to a friend's house in the country, in order to prepare himself for baptism. His religious opinions were still to some extent unformed, and even his habits by no means altogether such as his great change demanded. He mentions, for example, that during this time he broke himself off a habit of profane swearing, and in other ways sought to discipline his character and conduct for the reception of the sacred rite. He received baptism in Easter following, in his thirty-third year; and along with him his son Adeodatus and his friend Alypius were admitted to the Christian church. Monica, his mother, had rejoined him, and at length rejoiced in the fulfilment of her prayers. Dying before his return to his native country, her last hours were gladdened by his Christian sympathy. She implored him to lay her body anywhere, but wherever he might be to remember her "at the altar of the Lord," a devout duty which he invites others to share with him, so that her last request may, "through the prayers of many," receive a more abundant fulfilment.

Augustine went back to Rome for a short period and then returned to his native city, where he took up his abode in retirement, forming, with some friends who joined him in devotion, a small religious community, which looked to him as its head. They had all things in common, as in the early church, and fasting and prayer, Scripture reading and almsgiving, formed their regular occupations. Their mode of life was not formally monastic according to any special rule, but the experience of this time of seclusion was, no doubt, the basis of that monastic system which Augustine afterwards sketched, and which derived from him its name. Solitary monasticism had sprang up in the Egyptian deserts before this. The life of St Anthony by Athanasius had widely diffused the fervour for religious solitariness, and greatly touched Augustine at this period of his profession. It did not remain for him, therefore, to originate the monastic idea; but the association of monks in communities under a definite order and head received a special impulse both from Ambrose and his illustrious convert. As may be imagined, the fame of such a convert in such a position soon spread, and invitations to a more active ecclesiastical life came to him from many quarters. He shrank from the responsibility, but his destiny was not to be avoided. After three years spent in retirement he took a journey to Hippo, to see a Christian friend, who desired to converse with him as to his design of quitting the world and devoting himself to a religious life. He was the less reluctant to make this journey, because there being already a bishop at Hippo he hoped to escape all solicitation. But although the Christian community there had a bishop, they wanted a presbyter; and Augustine being present at the meeting called to choose a presbyter, the people unanimously chose him. He burst into tears, and would fain have escaped; but the church could not spare his services. He was ordained to the presbyterate, and in a few years afterwards he was made coadjutor to the bishop, and finally became sole bishop of the see.

Henceforth Augustine's life is filled up with his ecclesiastical labours, and is more marked by the series of his numerous writings and the great controversies in which they engaged him than by anything else. Already he had distinguished himself as an author. He had written several



philosophical treatises; he had combated the scepticism of the New Academy (*Contra Academicos libri tres*, 386 A.D.); he had treated of the "Blessed Life" (*De vita beata*, 386) and of the "Immortality of the Soul" (*De immortalitate anime*, 387); he had defended the church against the Manichæans, whose doctrines he had formerly professed. "When I was at Rome," he says (*Retract.*, i. 7), "after my baptism, and could not hear in silence the vaunting of the Manichæans over true Christians, to whom they are not to be compared, I wrote two books, one on *The Morals of the Catholic Church*, and the other on *The Morals of the Manichæans*." These tracts or pamphlets, for they are little more, were written in the year 388, about two years after his conversion. Later, in 395, and again in 400, he pursued the controversy with the Manichæans, making an elaborate reply, in the latter year, to his old associate and friend Faustus. The reply was provoked by an attack made by Faustus on the Catholic faith, which the "brethren" invited Augustine to answer. This he did characteristically and energetically by giving in succession "the opinions of Faustus, as if stated by himself," and his own in response. It was natural that the Manichæan heresy, which had so long enlaved his own mind, should have first exercised Augustine's great powers as a theological thinker and disputant. He was able from his own experience to give force to his arguments for the unity of creation and of spiritual life, and to strengthen the mind of the Christian church in its last struggle with that dualistic spirit which had animated and moulded in succession so many forms of thought at variance with Christianity.

But the time was one of almost universal ecclesiastical and intellectual excitement; and so powerful a mental activity as his was naturally drawn forth in all directions. Following his writings against the Manichæans come those against the Donatists. This controversy was one which strongly interested him, involving as it did the whole question of the constitution of the church and the idea of catholic order, to which the circumstances of the age gave special prominence. The Donatist schism sprang out of the Diocletian persecutions in the beginning of the century. A party in the Church of Carthage, fired with fanatical zeal on behalf of those who had distinguished themselves by resistance to the imperial mandates and courted martyrdom, resented deeply the appointment of a bishop of moderate opinions, whose consecration had been performed, they alleged, by a *traitor*. They set up, in consequence, a bishop of their own, of the name of Majorinus, succeeded in 315 by Donatus. The party made great pretensions to purity of discipline, and rapidly rose in popular favour, notwithstanding a decision given against them both by the bishop of Rome and by the Emperor Constantine, to whom they personally appealed. Augustine was strongly moved by the lawlessness of the party, and launched forth a series of writings against them, the most important of which survive, though some are lost. Amongst these are *Seven Books on Baptism*, and a lengthened answer, in three books, to Petilian, bishop of Cirta, who was the most eminent theologian amongst the Donatist divines. At a somewhat later period, about 417, he wrote a treatise concerning the correction of the Donatists (*De Correctione Donatistarum*), "for the sake of those," he says in his *Retractions*, ii. c. 48, "who were not willing that the Donatists should be subjected to the correction of the imperial law." In these writings, while vigorously maintaining the validity of the Catholic Church as it then stood in the Roman world, and the necessity for moderation in the exercise of church discipline, Augustine yet gave currency, in his zeal against the Donatists, to certain maxims as to the duty of the civil power to control schism, which were of evil omen, and

have been productive of much disaster in the history of Christianity.

The third controversy in which Augustine engaged was the most important, and the most intimately associated with his distinctive greatness as a theologian. As may be supposed, from the conflicts through which he had passed, the bishop of Hippo was intensely interested in what may be called the anthropological aspects of the great Christian idea of redemption. He had himself been brought out of darkness into "marvellous light," only by entering into the depths of his own soul, and finding, after many struggles, that there was no power but divine grace, as revealed in the life and death of the Son of God, which could bring rest to human weariness, or pardon and peace for human guilt. He had found human nature in his own case too weak and sinful to find any good for itself. In God alone he had found good. This deep sense of human sinfulness coloured all his theology, and gave to it at once its depth—its profound and sympathetic adaptation to all who feel the reality of sin—and that tinge of darkness and exaggeration which as surely have repelled others. When the expression Augustinianism is used, it points especially to those opinions of the great teacher which were evoked in the Pelagian controversy, to which he devoted the most mature and powerful period of his life. His opponents in this controversy were Pelagius, from whom it derives its name, and Celestius and Julianus, pupils of the former. Pelagius was a British monk. Augustine calls him *Brijo*; and Jerome points to his Scottish descent, in such terms, however, as to leave it uncertain whether he was a native of Scotland or Ireland (*habet progeniem Scotia gentis de Britannorum vicinia*). He was a man of blameless character, devoted to the reformation of society, full of enthusiasm, and that confidence in the natural impulses of humanity which often accompanies philanthropic enthusiasm. Travelling to Rome about the beginning of the 5th century, he took up his abode for a time there, and soon made himself conspicuous by his activity and opinions. His pupil Celestius carried out the views of his master with a more outspoken logic, and was at length arraigned before the bishop of Carthage for the following, amongst other, heretical opinions:—(1.) That Adam's sin was purely personal, and affected none but himself; (2.) That each man, consequently, is born with powers as incorrupt as those of Adam, and only falls into sin under the force of temptation and evil example; (3.) That children who die in infancy, being untainted by sin, are saved without baptism. Views such as these were obviously in conflict with the whole course of Augustine's experience, as well as with his interpretation of the catholic doctrine of the church. And when his attention was drawn to them by the trial and excommunication of Celestius, he undertook their refutation, first of all, in three books on *Forbearance of Sin and Baptism*; addressed to his friend Marcellinus, in which he vindicated the necessity of the baptism of infants because of original sin and the grace of God by which we are justified (*Retract.*, ii. c. 23). This was in 412. In the same year he addressed a further treatise to the same person, "My beloved son Marcellinus," on *The Spirit and the Letter*. Three years later he composed two further treatises on *Nature and Grace*, and the relation of the *Human to the Divine Righteousness*. The controversy was continued during many years in no fewer than fifteen treatises. Upon no subject did Augustine bestow more of his intellectual strength, and in relation to no other have his views so deeply and permanently affected the course of Christian thought. Even those who most usually agree with his theological stand-point will hardly deny that, while he did much in these writings to vindicate divine truth and to expound the true relations of the divine and human.

he also, here as elsewhere, was hurried into extreme expressions as to the absoluteness of divine grace and the extent of human corruption. Like his great disciple in a later age—Luther—Augustine was prone to emphasise the side of truth which he had most realised in his own experience, and, in contradistinction to the Pelagian exaltation of human nature, to depreciate its capabilities beyond measure. There are few thoughtful minds who would not concede the deeper truthfulness of Augustine's spiritual and theological analysis, in comparison with that of his opponent, as well as its greater consistency with Scripture; but there are also few who would now be disposed to identify themselves with the dogmatism of the orthodox bishop any more than with the dogmatism of the heretical monk. And on one particular point, which more or less runs through all the controversy—the salvation of infants—the Christian consciousness, in its later and higher growth, may be said to have pronounced itself decisively on the side of the monk rather than of the bishop.

In addition to these controversial writings, which mark the great epochs of Augustine's life and ecclesiastical activity after his settlement as a bishop at Hippo, he was the author of other works, some of them better known and even more important. His great work, the most elaborate, and in some respects the most significant, that came from his pen, is *The City of God*. It is designed as a great apologetic treatise in vindication of Christianity and the Christian church,—the latter conceived as rising in the form of a new civic order on the crumbling ruins of the Roman empire,—but it is also, perhaps, the earliest contribution to the philosophy of history, as it is a repertory throughout of his cherished theological opinions. This work and his *Confessions* are, probably, those by which he is best known, the one as the highest expression of his thought, and the other as the best monument of his living piety and Christian experience. *The City of God* was begun in 413, and continued to be issued in its several portions for a period of thirteen years, or till 426. The *Confessions* were written shortly after he became a bishop, about 397, and give a vivid sketch of his early career. To the devout utterances and aspirations of a great soul they add the charm of personal disclosure, and have never ceased to excite admiration in all spirits of kindred piety. His systematic treatise on *The Trinity*, which extends to fifteen books, and occupied him for nearly thirty years, must not be passed over. "I began," he says (*Retract.*, ii. 15), "as a very young man, and have published in my old age some books concerning the Trinity." This important dogmatic work, unlike most of his dogmatic writings, was not provoked by any special controversial emergency, but grew up silently during this long period in the author's mind. This has given it something more of completeness and organic arrangement than is usual with him, if it has also led him into the prolonged discussion of various analogies, more curious than apt in their bearing on the doctrine which he expounds. The exegetical writings of Augustine,—his lengthened *Commentary on St John* and on the *Sermon on the Mount*, &c.,—and then his *Letters*, remain to be mentioned. The former have a value from his insight into the deeper spiritual meanings of Scripture, but hardly for their exegetical characteristics. The latter are full of interest in reference to many points in the ecclesiastical history of the time, and his relation to contemporary theologians like Jerome. They have neither the liveliness nor variety of interest, however, which belong to the letters of Jerome himself. The closing years of the great bishop were full of sorrow. The Vandals, who had been gradually enclosing the Roman empire, appeared before the gates of Hippo, and laid siege to it. Augustine was ill with his last illness, and could

only pray for his fellow-citizens. He passed away during the progress of the siege, on the 28th of August 430, at the age of seventy-five, and was spared the indignity of seeing the city in the hands of the enemy.

The character of Augustine, both as a man and a theologian, has been briefly indicated in the course of our sketch. Little remains to be added without entering into discussions too extended for our space. None can deny the greatness of Augustine's soul—his enthusiasm, his unceasing search after truth, his affectionateness, his ardour, his self-devotion. And even those who may doubt the soundness or value of some of his dogmatic conclusions, cannot hesitate to acknowledge the depth of his spiritual convictions, and the strength, solidity, and penetration with which he handled the most difficult questions, and wrought all the elements of his experience and of his profound Scriptural knowledge into a great system of Christian thought.

The best complete edition of Augustine's writings is that of the Benedictines, in 11 vols. folio, published at Paris, 1679–1800, and reprinted in 1836–38 in 22 half-volumes. Tillemont, in his *Ecclesiastical History*, has devoted a quarto volume to his life and writings. Two extensive monographs have appeared on him; the one by Kloth, a Roman Catholic (Aachen, 1840), and the other by Bindemann, a Protestant (Berlin, 1844, 1855). See also Ritter's *Hist. of Christian Philosophy*, vol. i.; Böhlinger's *Hist. of the Church*; Dr P. Schaff's *St Augustine* (Berlin, New York, and London, 1854); Nourisson, *La Philosophie de S. Augustin* (Paris, 1866); A. Dorner, *Augustinus* (Berlin, 1872); Neander's *Church History*; Mosley's *Augustinian Doctrine of Predestination*, 1855; Jameson's *Sacred and Legendary Art*. (J. T.)

AUGUSTINE, or AVSTIN, ST, the first archbishop of Canterbury, was originally a monk in the Benedictine convent of St Andrew at Rome, and was educated under the famous Gregory, afterwards Pope Gregory I, by whom he was sent to Britain with forty monks of the same order, to carry out the favourite project of converting the English to Christianity. The missionaries set out with much reluctance, for the journey was long and perilous, and on the way they endeavoured to persuade the Pope to allow them to return. His orders, however, were peremptory; they proceeded, therefore, on their journey, and at last landed, some time in the year 596, on the isle of Thanet. Having sent interpreters to explain their mission to King Ethelbert, whose queen, Bertha, was a Christian, they received from him permission to preach and to make converts. He treated them with great favour, held a public conference with them, and assigned them a residence at Durovernum, now Canterbury. His own conversion to the Christian faith, which took place shortly afterwards, had a powerful influence with his subjects, who joined the new church in great numbers. Augustine, seeing the success of his labours, crossed to France, and received consecration at Arles. He then despatched messengers to the Pope to inform him of what had been done, and to propose for his consideration certain practical difficulties that had arisen. They brought back the *pallium*, with which Augustine was consecrated as first archbishop of Canterbury, and certain vestments and utensils for the new churches. Gregory also gave most prudent counsel for dealing with the new converts, strongly advising the archbishop to make the change of faith, so far as ceremonial went, as gradual as possible, and not on any account to wound the feelings of the people by destroying their temples, but rather to consecrate them afresh, and use them for Christian worship. Augustine passed the remainder of his life principally at Canterbury, where he died, probably in 607, on the 26th May. See *Lives of the English Saints*, No. III. 1847, and Mrs Jameson's *Legends of the Monastic Orders*.

AUGUSTINIANS, a monastic order of the Roman Catholic Church, claiming to have received its rule from St Augustine. See ABBEY and MONASTICISM.

**AUGUSTOVO**, a city in Russian Poland, in the government of Suwalki, situated on the river Netta, near a lake, which abounds in fish. It was founded in 1557 by Sigismund II. (Augustus), and is laid out in a very regular manner, with a large market-place. It carries on a large trade in cattle and horses, and manufactures linen and huckaback. Population, 9383.

**AUGUSTUS AND THE AUGUSTAN AGE.** The name of Augustus was the title of honour given by the Romans to the emperor Caius Julius Caesar Octavianus, or, as he was originally designated, Caius Octavius. This title was intended to be hereditary in his family, but all the succeeding Caesars or emperors of Rome continued to adopt it, long after they had ceased to be connected with the first Augustus by blood. The era of Augustus formed an illustrious epoch in Roman history, and was distinguished for its splendid attainments in arts and arms, and more especially in literature. The Romans in later times looked back to the age of Augustus with great complacency, as the most prosperous and the most distinguished in their annals. The name of the "Augustan Age" has been specially applied to it in modern times, and the same title has been given, with more or less justice, to certain epochs in modern history as the highest compliment to their glory. The reign of Louis XIV. is called the Augustan age of France; the reign of Anne, the Augustan age of England.

Caius Octavius was the son of a noble Roman of the same name, of the plebeian order. The father had married Atia, the daughter of Julia, sister to the great C. Julius Caesar, who was accordingly great-uncle to the young Octavius. Caesar, the dictator, having no son of his own, took an interest in this youth, caused him to be enrolled among the Patricians, and bred him with a view to the highest honours of the republic. Already, in his eighteenth year, he had chosen him for his "master of the horse," but this was a merely nominal distinction. The young man was sent to carry on his education at the camp at Apollonia in Illyricum, and there, at the age of nineteen, he heard of his great kinsman's assassination (44 a.c.) He had already become a favourite with the soldiers, who offered to escort him to Rome, and follow his fortunes. But this he declined, and crossed over alone to Italy. On landing he learnt that Caesar had made him his heir and adopted him into the Julian gens, whereby he acquired the designation of C. Julius Caesar Octavianus. The inheritance was a perilous one; his mother and others would have dissuaded him from accepting it, but he, confident in his abilities, declared at once that he would undertake its obligations, and discharge the sums bequeathed by the dictator to the Roman people. M. Antonius had possessed himself of Caesar's papers and effects, and made light of his young nephew's pretensions. The liberators paid him little regard, and dispersed to their respective provinces. Cicero, much charmed at the attitude of Antonius, hoped to make use of him, and flattered him to the utmost, with the expectation, however, of getting rid of him as soon as he had served his purpose. Octavianus conducted himself with consummate adroitness, making use of all competitors for power, but assisting none. Considerable forces attached themselves to him. The senate, when it armed the consuls against Antonius, called upon him for assistance; and he took part in the campaign in which Antonius was defeated at Mutina, but both the consuls, Hirtius and Pansa, slain. The soldiers of Octavianus demanded the consulship for him, and the senate, though now much alarmed, could not prevent his election. He now effected a junction with Antonius, who quickly overthrew the power of the republican party in their stronghold, the Cisalpine provinces, with the death of Decimus Brutus, the ablest of the liberators. Thereupon Octavianus and Antonius, taking Lepidus into union with them, met on

the river Rhenus near Bononia, and proclaimed themselves a triumvirate for the reconstitution of the commonwealth. They divided the western provinces among them, the east being held for the republic by M. Brutus and Cassius. They drew up a list of proscribed citizens, entered Rome together, and caused the assassination of three hundred senators and two thousand knights. They further confiscated the territories of many cities throughout Italy, and divided them among their soldiers. Cicero was murdered at the demand of Antonius. The remnant of the republican party took refuge either with Brutus and Cassius in the East, or with Sextus Pompeius, who had made himself master of the seas.

Octavianus and Antonius crossed the Adriatic in 42 a.c. to reduce the last defenders of the republic. Brutus and Cassius were defeated, and fell at the battle of Philippi. War soon broke out between the victors, the chief incident of which was the siege and capture by famine of Perusia, and the alleged sacrifice of three hundred of its defenders by the young Caesar at the altar of his uncle. But peace was again made between them. Antonius married Octavia, his rival's sister, and took for himself the eastern half of the empire, leaving the west to Caesar. Lepidus was reduced to the single province of Africa. Meanwhile Sextus Pompeius made himself formidable by cutting off the supplies of grain from Rome. The triumvirs were obliged to concede to him the islands in the western Mediterranean. But Octavianus could not allow the capital to be kept in alarm for its daily sustenance. He picked a quarrel with Sextus, and when his colleagues failed to support him, undertook to attack him alone. Antonius, indeed, came at last to his aid, in return for military assistance in the campaign he meditated in the East. But Octavianus was well served by the commander of his fleet, M. Vipsanius Agrippa. Sextus was completely routed, and driven into Asia, where he perished soon afterwards. Lepidus was an object of contempt to all parties, and Octavianus and Antonius remained to fight for supreme power.

The alliance of Antonius with Cleopatra, queen of Egypt, alienated the Romans from him. They now gladly accepted the heir of Caesar as the true successor of the most illustrious of their heroes. It was felt almost universally that the empire required a single head, and that repose could only be assured by the sovereignty of the chief of its armies. The battle of Actium, followed by the death of Antonius, 31 a.c., raised the victor to universal empire. Nevertheless, Octavianus did not hasten to assume his position. He first regulated the affairs of Egypt, which he annexed to the Roman dominions, then lingered for a time in Greece, and entered upon a fifth consulship at Samos, 29 a.c. On his return to Rome he distributed the vast sums he had accumulated among the people and the soldiers, while he soothed the pride of the nobles by maintaining unchanged the outward show of republican government. Of his personal history from this period there remains little to be said. He continued to reside almost constantly at Rome and in the neighbourhood, making one expedition into Spain, 27 a.c., and a journey through Greece in 21, on which occasion he advanced into Syria, and received back the standards taken by the Parthians from Crassus. In 16 a.c. he went to Gaul to regulate the affairs of that province, an expedition which he repeated, 9 a.c. But from thenceforth he intrusted the defence of the position to his lieutenants, and more especially to the young princes of his own family. The empire continued to enjoy profound internal tranquillity. More than one plot was formed against the head of the state by some of the discontented nobility, but these were discovered and disconcerted; and when it was evident that they met with no favour from the people generally, he

could afford to treat them with a signal clemency, which seems to have secured him from any further attempts. The serenity and placability which he displayed in his latter years forms a marked contrast to his jealousy and ferocity at an earlier period; and the character of the Emperor Augustus Caesar has been a problem to historians in consequence. The life of the emperor was prolonged to the year 14 A.D. He died at Nola in his seventy-fifth year, after holding supreme power in the state for nearly half a century.

During the years which had intervened between his accepting the inheritance of Caesar, and his attaining to Caesar's undivided sovereignty, the young aspirant had been meditating how to secure the retention of his power. At first, excited by fears for his own personal safety, and urged by the examples of party leaders around him, and of others who had gone before him, he plunged into a career of wholesale bloodshed, and cut off without scruple every public man from whose principles or whose passions he might have cause of apprehension. A large proportion, perhaps, of the senators and nobles had perished in the prescriptions and bloody wars of the triumvirate. Still it could not be expected that the germs of republican sentiment would ever be wholly eradicated. The sense of patriotism and the sense of interest would not fail to raise up enemies to the sovereign ruler of the Roman commonwealth. The conqueror's first object was to protect himself by force of arms, his next to soothe the passions of the class from whose resentment he had most cause of fear, and after that to raise up another class in direct sympathy with himself to balance the power which the first must necessarily retain in a well-ordered government. It was to the attainment of these three objects that Octavianus directed his organisation of the commonwealth.

The powers of the emperor or commander of the Roman army ceased on his return to the city. He then became once more a plain citizen. If war again arose he must seek his reappointment to command with the usual forms. Caesar had not trusted his countrymen so far. He had claimed from them the title of emperor in perpetuity. With this title prefixed to his name, he continued to be still the commander of the legions, whether in the city or in the provinces. With this power his successor dared not dispense. On his arrival at Rome from the East he at once required the senate to accord it to him, as to his uncle before him; but he pretended only to ask it for a limited period of five years. At the expiration of that term, however, he assumed it again and again, though each time for ten years only, but never actually relinquished it to the end of his career. He thus received authority to command the whole force of the state in chief, and the officers who acted under him became simply his lieutenants. If they gained victories, the honours of the triumph were reserved for the emperor "under whose auspices" they were reputed to have served. It followed that all the provinces on the frontiers, or in which armies were maintained, were placed under the emperor's direct authority, while it was only the central and peaceful portions of the empire that were handed over to the government of the senate. The imperial provinces were administered by the *legati Caesaris*, the senatorial by *proconsuls*.

The person of the emperor was thus secured as far as the power of the sword could secure it. But he was anxious that the source of this power should not be too apparent. The second Caesar wished to maintain the appearance at least of government by the constitutional powers of the republic. The senate had once been practically the ruling power, as far as it was not actually controlled by the masters of the legions. He would not degrade it in its own estimation, or in the estimation of the people, any

further, at least, than might be necessary for his main object. He caused himself to be appointed censor, not for one but for five years, in order to give him full time to revise the list of senators, to supply the fearful gaps in the ranks of the old nobility, and to expel such members, and many they were, who seemed unworthy, from their foreign extraction, their low birth, their scanty means, or their bad character, to have a place in that august assembly. The irregularities of the epoch which he hoped now to close had filled its benches with personages who degraded the order in the eyes of genuine citizens. The nobles and good citizens generally hailed this revision with deep satisfaction. It accorded with the national taste as well as with historical traditions. From the individual resentments it provoked, it was an act of some personal danger to the censor; but the danger was more than repaid by the popularity attending upon it, which was enhanced to the utmost by the liberality with which provision was made for raising some of the poor but honourable members of the order to the standard of property now to be required of them.

The emperor placed himself at the head of this reconstituted body, by assuming the office and title of *Princeps Senatus*. The office was indeed little more than nominal; it gave the right of proposing measures and of speaking first in the highest legislative assembly of the state, and having been borne in earlier times by some of the most distinguished of Roman patriots, it carried with it the respect and affection of the people. The titular precedence it gave was all the more valuable, inasmuch as it might be conceded without a blush by the sturdiest republican in the senate. But it was the consul who possessed practically the chief authority in the assembly. Octavianus had been already five times consul, and he shrank from seizing in perpetuity an office which, according to Roman ideas, differed in nothing from royalty, except that it was elective, and that it was limited to the tenure of a single year. Yet he could hardly afford to yield it to the citizen whom the people might at any time elect to thwart or to rival him. What should he do? He took what was certainly a bold step. It was a manifest innovation upon the forms of the free state when he required from the citizens the perpetual "potestas," or power of the consulship, at the same moment that he resigned the office itself, and suffered consuls to be annually elected to sit, one on each side of him, in the senate. The potestas which was thus conceded to him rendered him the head of the state, both in its legislative and executive departments. When he quitted the city he carried with him into the provinces a proconsular authority, and became to all intents and purposes king for life of the Romans and of their subjects. Even in the senatorial provinces he was now recognised as supreme; and thus it was that in him were centred all the great political functions which had been hitherto divided by the great assembly of the Roman magnates.

But the emperor did not limit his views to becoming the chief of the nobles. It was the part of a wary statesman to associate himself not less intimately with the opposite faction, which, under the name of the plebeians, had aimed at securing co-ordinate power with the patricians. The original meaning of these designations had indeed long been lost. The plebeians could boast many families as eminent both for honours and possessions as their haughty rivals. Step by step they had won an equal share with them in political privileges. But the class which still bore the title of plebeian was much more widely extended, and embraced the great mass of the knights and men of business in the city, and also of the citizens settled throughout the provinces. This large class had for more than a century contended with the nobles for the perquisites of office, and their mutual rivalry had

armed Sulla against Marius and Cæsar against Pompeius. The heir of Cæsar inherited the favour of the plebeians, and was bound to requite it by distinguished patronage. The plebeians were still the electors to the tribunate, and still regarded the tribunes as their protectors against the encroachments of the patricians represented by the senate. The tribunes had proved themselves most useful allies to Cæsar, and might yet again array themselves in support of the faithful inheritor of his principles. The emperor proposed to balance the consular potestas by assuming at the same time a tribunician potestas also. He thus endowed himself with the authority of the tribune for life, and assured the commons of the city and empire that he could at any time exercise the formidable veto upon the proceedings of the consuls which had served them so well, even down to recent times. Thus did he become emperor indeed,—the sovereign both of the nobles and the people in the city, as well as the commander of the army in the field and in the provinces.

There remained yet another sovereign authority in the state, namely, that which the chief pontiff exercised over the affairs of religion. However much the religious sentiment had been weakened throughout the Roman world, there was yet enough superstition left among the citizens to confer great and sometimes overruling influence upon the legitimate interpreter of divine things to the nation. The senate had exercised this power with great effect, as long as the appointment to the chief pontificate rested with the patrician curia. Of late years, however, this important dignity had been thrown open to the commons also. Octavianus was well pleased to accept it on the nomination of the whole people combined. He allowed, indeed, his former colleague Lepidus to retain it unmolested during his lifetime, but upon his death he assumed himself the exalted position which he might hesitate to intrust to any other. With this last addition to his prerogatives the emperor might well be content. The name of king he had from the first utterly repudiated. The office of dictator approached too near to that of a king to be acceptable to a ruler, who studied to confine himself within the limits of the republican constitution. Yet there still lacked some general appellative which might reflect in a single word the full dignity and power resulting from the combination of so many honours and prerogatives. The emperor proposed at first, it is said, to assume the name of *Romulus*; but Romulus had been a king; and further, Romulus had been destroyed, according to the tradition, by the senate, just as Cæsar had been in later times. Such associations were ominous. At last he fixed upon the epithet *Augustus*, a name which no man had borne before, and which, on the contrary, had been applied to things the most noble, most venerable, and most sacred. The rites of the gods were called *august*; their temples were *august*. The word itself was derived from the holy *auguries*; it was connected in meaning with the abstract term *authority*, and with all that increases and flourishes upon earth. The use of this glorious title could not fail to smooth the way to the general acceptance of the divine character of the mortal who was deemed worthy to bear it. The senate had just decreed the divinity of the defunct Cæsar; the courtiers were beginning now to insinuate that his successor, while yet alive, enjoyed an effluence from deity; the poets were even suggesting that altars should be raised to him; and in the provinces, among the subjects of the state at least, temples to his divinity were actually rising, and the *cult* of Augustus was beginning to assume a name, a ritual, and a priesthood.

Augustus, as we may now call him, viewed all this with secret satisfaction. It was one of his first objects, indeed, to restore the outward show at least of reverence for divine

things, and re-establish the old Roman religion on its firm political basis. It was easy to rebuild, or cause to be rebuilt, the fallen or dilapidated temples of the national gods. The nobles paid their court to their master by seconding his efforts in this direction. The Pantheon, the temple of all the gods, if such was its original destination, remains still as a monument of his minister Agrippa's munificence; but Virgil would assure us that not less than three hundred "grand" temples were erected throughout the city. Perhaps, indeed, these were mostly the *scellæ* or chapels of the Lares, which are placed at the corners of the streets. Augustus took the sentiment of the people at a favourable moment. They were thoroughly sickened by the miseries of the civil wars; they were ashamed of the crimes for which the whole nation were more or less responsible; they were eager to rush into any scheme of expiation and reparation that should be offered to them, and lend their hands to the material work of restoring at least the outward semblance of penitence for sin, and thankfulness for the mercy vouchsafed them. There can be no doubt that the conscience of the nation was awakened to a sense of the divine retribution under which they had suffered, but which had been at last averted under the blessed influence of the ruler whom they had at last chosen. The Romans had not lost their belief in a divine Providence, which oppressed them with anxiety and terror, however little they connected it with a sense of moral duty.

The spirit of materialistic philosophy had, however, been rife among them, and during the past century the anti-religious dogmas of Epicurus had sapped the belief of the educated and literary classes. The patrician youth of Rome had been trained in the schools of Greece, and especially at Athens, or had been placed under the teaching of Greek instructors at home; and of the three contending schools, the Stoics, the Epicureans, and the Academics, the second was that which had carried off far the greater number of disciples. The men of books or of speculative character might be generally Academics, and claim Cicero as their noblest leader; the men of imagination and deep religious fervour might follow, with Cato and Brutus, the teaching of the Stoics; but the practical men, the men of arts and arms and business, if they adhered to any school of thought at all, were almost all, like Cæsar himself and his associates generally, addicted to the easy precepts and still laxer morality of Epicurus. This philosophy was noted for its utter denial of Providence and, for all practical objects, of divinity altogether. None of these rival systems, whatever degrees of right sense and reason they might embrace respectively, could sanction any real belief in the still current mythology of the national worship, which was assailed and derided on all sides. Nevertheless, such was the pertinacious adherence of the Roman people to their ancient forms, especially where they had any connection with their national polity, that the outward ritual of their religion was still maintained, though a mere shadow of its former substance. Statesmen, indeed, had invented a formula for reconciling their actual unbelief with their outward profession. Varro had said, and the dictum was favourably accepted, that the ancient beliefs were to be upheld as a matter of public policy. 'Such, no doubt, was the principle on which Augustus, who was himself neither a believer nor a philosopher, but a politician only, proceeded, when he assumed the part of a restorer of the national religion. He touched, with great sagacity, a chord which vibrated to the heart of the people, who firmly believed that the destinies of the city were bound up with the due observance of the ancient rites, and statesmen looked on with decorous acquiescence at shows and ceremonies to which they attached no significance whatever.

The world "composes its countenance to the expression

assumed by the king." Such was the aphorism of the man of the world, and in this particular Augustus was a king indeed. The Romans rushed forward in the course he marked out for them. His word dictated the fashions of the day, not in sentiment only, but in many particulars of external conduct. He was anxious to restore the dignity of the Roman citizen, as one of the conquering race which ruled its subjects as much by the prestige of its character as by its arms, and he resented all relaxation from the strait-laced discipline of the ancients, even to the petty matters of their dress and deportment. He marked his sovereign displeasure at the degenerate Romans who indulged in the loose habiliments of Greece. "Are these," he exclaimed, in the language of Virgil, "the rulers of the world, the nation of the gown!" And in order to keep up the high distinction of Roman citizenship at a period when provincials from all sides were crowding into it, he reversed, in this single instance, the policy of Caesar, and was very sparing in granting admission to the Roman franchise. He was, indeed, extremely careful in striking a balance between the tendency of the age to a general fusion of castes and privileges and the ancient spirit of exclusion, in which he thought the strength of the republic still really reposed. The policy of Augustus was one, on the whole, of cautious and moderate reaction. He made an effort to stay the process of disintegration, which he found so rife throughout the vital forces of the empire. The lawlessness of his own usurpation did indeed combine with the gross selfishness of his personal character to sap the moral principles of society, and render its ultimate dissolution inevitable; but he made a vigorous effort to stem the tide, and succeeded in giving the Roman world a period of rest in the downward path which it was generally pursuing.

The character of the period, however, as an epoch of rest for reflection and self-control, was chiefly marked in the literature, which, more than anything else, has contributed to give it the name of the Augustan Age. The religious sentiment which has been described, resting as it did upon a deep sympathy with historical antiquity, coloured by a bold and vigorous imagination, is reflected in the poetry of Virgil, and more particularly in the spirit of his great epic, the *Æneid*. No doubt, both depth and tenderness of feeling may be traced even in the eclogues of the same master, however slight for the most part their subjects, and however imitative their treatment. The *Georgics* present us with more serious and dignified characteristics, and though these pieces are directed mainly to the practical treatment of practical operations, they admit of high moral as well as religious colouring. They recall the Roman reader to the moral foundations of the national character, its honest simplicity, its love of nature, its devotion to labour, its conviction that industry is the appointed path to virtue and to honour. But this moral feeling is elevated by a sense of the divine within man and around him. The Roman husbandman, the breed of heroes, is never suffered to forget that there is a God and a Providence, or that the favour of the divine power has always fallen upon the industrious and the virtuous. "Thus it is that Etruria of old, and Rome in later times, waxed illustrious and mighty"; thus that the city on the seven hills became the fairest object of creation." The *Georgics* are undoubtedly animated throughout with a religious sentiment, and bespeak the high religious purpose of their author. But in the *Æneid* this religious sentiment and purpose are both still more distinctly proclaimed to us. The great epic of Virgil, the national epic of the Roman people, glorifies the divine Providence which founded Rome in the beginning, and carried her through all her triumphs to the consummation of her greatness in the era of Augustus.

It begins with the divine *Æneas*, and it leads us on to the divine *Cæsar*. The greatness and the weakness of the hero of the poem equally tend to this one end, the illustration of the Providence which has educed strength out of weakness, and overruled everything to the glory of the Roman people. The moral to be deduced from the story of *Æneas* is too plain for any Roman to mistake. The divinity which protects Rome is the Lord of heaven and earth and all that is therein. There is no God or Lord like unto Him. Blessed are the Romans who have this Lord for their God. The majesty of the Roman empire, now at the crowning summit of its progress, is the immediate efflux of this sovereign power, and the one is for ever bound up with the other. If such was the doctrine sung by Virgil, surely none could be more grateful to Augustus, the sovereign ruler of an empire so guided and protected.

The names of Virgil and Horace are familiarly united in every review of the age of Augustus; yet no two men can stand more in contrast one with the other in their personal character, in the scope of their writings, and in the influences they respectively exercised upon their contemporaries. Horace, as is well known, had been a republican in his youth; he had espoused the cause of Brutus and Cassius, and, while yet a student in the schools at Athens, had obtained a commission in their army. He fought in person in the battle of Philippi, and, as he tells us himself, threw away his shield in his rapid flight from the swords of the *Cæsarians*. From that time he abjured the losing cause, and obtained, perhaps without seeking it, the advice of the minister *Mæcenas*, by whom he was taken into favour and introduced to Augustus himself. However agreeable might be his temper and manners, it is not likely that the politic usurper would distinguish a mere upstart with admission to his society without at least tacitly exacting some return. The character of this poet's compositions, both in his lyrics and his satires and epistles, seems pretty clearly to betray the inspiration of the emperor and his astute associates. The most animated and imaginative of his pieces are almost invariably employed in sounding the praises of the *Cæsar* and his family. When he descends from his highest flights of poetry, he finds congenial matter for his muse in delicate flattery of *Mæcenas* and other magnates of the court. But it will be observed that he seldom, if ever, addresses the haughty nobles of Rome except in a strain of prudential advice, soothing their pride, but lowering their ambition, and directing them to seek contentment and happiness not in objects of public interest, but in the tranquil enjoyment of ease, which he dignifies with the name of philosophy. The poetry of Horace is full of pleasing sentiments, but it contains perhaps no single strain of generous and ennobling enthusiasm. Such feelings it was the policy of Augustus to discourage, and the policy of Augustus is faithfully represented in the utterances of his courtly flatterer. But there was another task imposed upon him, and it is to this that his satires and epistles are more commonly directed, namely, to put out of countenance the offensive self-assertion of the "new men" of the empire, the men whom the fortunes of the civil war had suddenly raised from their native obscurity, and enriched or ennobled, notwithstanding the barrenness of their origin and the vulgarity of their breeding. Augustus wanted, no doubt, to tame the aspiring spirits of his genuine nobles, but he shrank from driving them to desperation by swamping them with an inundation of base-born inferiors, perhaps their own former clients and freedmen. It was part of Horace's office, as a gentleman usher at court, to discountenance all such undue pretensions, and shut the door with consummate urbanity upon the most disagreeable or the most importunate of the courtiers. He

possessed in perfection both the delicate irony and the graceful amenity which are essential to the performance of a task so critical. Doubtless Horace, in his own peculiar line, exercised as great an influence in Roman society as Virgil. The laughing philosopher was no less a power among his contemporaries than the religious devotee. Each of them, in his several way, performed an immense service to the government under which he enjoyed favour and reward; nor can we deny that, considering how necessary the government of Augustus was to the bleeding commonwealth, each in his several way did an invaluable service to his country.

Nor, though we may admit that irony and perniage were Horace's forte, should we do him justice if we supposed that he had no feelings of genuine tenderness and earnestness. Even Horace had his instinctive sense of religious duty, which peeps out occasionally from under the robe of his pretended philosophy, and shows that he recognised a principle of duty, and felt ill at ease in the consciousness of his own deficiencies. We may recognise in many of his later compositions his growing dissatisfaction with the worldly views of life which he had been wont to recommend, and some efforts at the attainment of higher sources of satisfaction. Both Virgil and Horace were cut off in middle life, but both, we imagine, had already entered into the cloud, and were painfully conscious that the commonwealth they loved had fallen into its decline, and that their own attempts to invigorate or to soothe it were little likely to prove availing. If Virgil deserves our admiration, Horace too is not unworthy of our sympathy; and it is well that we can part in such good temper from the two most perfect artists of the Roman, or perhaps of the ancient, world altogether.

Of Ovid, the third great poet of the Augustan Age, we can hardly think or speak so favourably. Ovid, too, was a genuine representative of his epoch, which occupied, however, the latter part of the career of Augustus, when the character of the age had begun to show manifest signs of deterioration. In the character of this poet, which may be abundantly gathered from his numerous works, there appears no religious feeling and no moral purpose. Nevertheless, his writings reflect, in some important particulars, the social tendencies of the epoch, and afford valuable illustrations of the genius of the Augustan Age. To the historian and archaeologist the *Fasts* presents a store of interesting information; but in this poetical account of the Roman calendar the writer undoubtedly proposed to meet a social want of the time. The work is in fact a *rationalis* of the divine offices, and expounds to the nation the "seasons and the reasons (*tempora cum causis*)" of the religious services which the emperor recommended to their pious attention. Minute and manifold as were the memorials of their past history, or of their accredited mythology, which the *cult* of the Roman temples enshrined, we can imagine how much they must have faded away from the recollection of the people generally during the century of confusion from which they had just emerged, and how even the priests and flamines of the national divinities must have stood in need of a learned interpreter of the rites which they mechanically performed. The *Fasts* is remarkable as a speaking witness to the fact of the ceremonial revival of the Augustan Age.

The generally immoral tendency of a great part of Ovid's poetry is well known; and it speaks all the worse for the character of the age that the writer could declare, and probably not without justice, that his personal conduct was purer than the sentiments with which he sought to please the public. The deterioration of sentiment between Virgil and Ovid is marked in the tone with which they speak in the higher flights of their respective poetry. The writer

of the *Æneid* fully maintains the pure standard of thought and expression which he received as a tradition from Homer, and which had been respected by the epic poets generally; but Ovid, in his *Metamorphoses*, an heroic, if not an epic, composition, allows himself to descend far below this exalted level, and is not only licentious in his language, but seems to choose, and of set purpose, the most licentious of the stories which his varied subject offers. Again, though Horace adopts the lighter tone and looser phraseology of the lyric poets of Greece, there is at least nothing meretricious in his style; he was not a corrupter of youth himself, nor were the models such which he proposed for adaptation. But Ovid descends to the imitation of a more wanton kind of poetry. He, too, seeks his models for the most part from among the Greeks, but they are the Greeks of a more degenerate age—the Greeks of the court of Alexandria, who pandered to the vicious tastes of a corrupt and degraded society. But, imitator as he doubtless was, Ovid had a strong personal individuality, and all his poetry is marked with the genuine sentiment of his age and country. Perhaps we trace more of the real man in his *Tristia* and *Ex Ponto*, in which he is thrown entirely on his own resources, though in the depth of his affliction and the decline of his powers, than in the abler and more interesting works in which he owed we know not how much to the Greeks before him.

We have, besides these, the remains of other poets, such as Tibullus and Propertius, who also hold up the mirror to their times, and assist us in scanning its character on all sides. But it will be well to pass them over in this brief sketch, and bring our review of the literature of the Augustan Age to a close with a notice of the great historian Livy. The consummate excellence in form and style of the work to which we refer bears witness to the intellectual accomplishments of the epoch. No doubt the Romans did much at a later period to improve their method of teaching, and to extend their acquaintance with the highest models of literary excellence. An age succeeded in which Rome was formed into an academy, like that of Athens or Alexandria, when all the arts and sciences of the time were taught or practised under the direct instruction of approved professors. Great were the merits of the historical literature of Rome at a later age, and illustrious are some of the men who distinguished themselves in its exercise. But, on the whole, a reasonable criticism will award to Livy the palm of merit at least in the two particulars just specified,—a palm which he may well contest even with the masters of the art in Greece. The form of Livy's history partakes in exquisite proportion of the descriptive, the narrative, and the dramatic; it is replete with personal characteristics, which bring us into direct acquaintance with the individuals of whom it treats; it abounds, moreover, in matter of antiquarian interest, which we who read it at a distance of nineteen centuries feel to be specially valuable, and which did not fail to attract the sympathy even of the writer's own contemporaries. The Romans in the time of Augustus were just beginning to be keenly self-conscious. They felt that they had attained to such a position in the world's history as no people before them had acquired. They were led by all the traditions of their youth to attribute their splendid success to the examples of national virtue paraded before them. They were sensible of the deep debt they owed to their ancestors, and they wanted to know who their ancestors were; they wanted to trace the features of their own character in the lineaments of the great men who had gone before them. Of these ancient heroes of the commonwealth they had hitherto imbibed a faint and vague conception from songs and poems and family or national traditions. The legends connected with their ritual and their laws and

institutions assumed the existence of those heroes, and the reality of the deeds imputed to them; but the men and their deeds were for the most part wrapped in obscurity, or presented under dubious colours. The voice of Livy's contemporaries muttered around him that of all their compatriots he should be held most in honour among them, who should bring these traditions of the past into the light of day, and make them pass among a generation, willing so to accept them, as genuine and accredited history. The history of Livy was the true product of the age, inasmuch as it answered to the call of the age. It presented Roman history to the Romans much as Shakespeare's dramas presented English history to the English; the history in both cases was just what the people wished to believe, and from thenceforth they so accepted and believed it.

As regards the style of Livy's composition, it is enough to say that it is generally regarded as the most perfect specimen of the Latin prose writing that we possess, and we may be pretty confident that if anything better had been written, posterity would not have suffered it to perish. It holds the middle place between the oratorical exuberance of Cicero and the philosophic sententiousness of Tacitus. While sentence follows sentence throughout in logical sequence, so that the thread of meaning and argument is never lost under a mass of verbiage, yet we are beguiled in our lengthened study by the repeated recurrence of passages of highly-imaginative colouring; we feel that if the historian sometimes deviates into poetry, he never misleads us with a show of empty rhetoric. The Roman people, as represented by Livy, retained the genuine strength and bluntness of their character. The teaching of their Greek instructors had had as yet little effect in seducing them into the conceits and affectations of the more frivolous people they had conquered. The history of Livy remains the noblest monument of the *Romanus honor*, the national dignity, which his countrymen so proudly contrasted with the *Graia licentia*, which was gradually enervating and degrading them. The spirit of the Augustan Age is set forth, perhaps at its best and brightest, in the illustrious history of Livy.

It is probable that Livy, who had been a republican in his heart, lived for the most part the retired life of a student, though he is said to have been employed in the education of some of the princes of the imperial family. He reflects the character of the earlier generation, among whom he was born, rather than of the later, in which he died, at an advanced age, in the fourth year of Tiberius. All the great poets above mentioned met an early death about the middle of the principate of Augustus, except Ovid, who survived to the eighth year of his successor. Accordingly, it is in Ovid, as might be expected, that we trace the first marks of degeneracy from the high standard of the Augustan literature—the Golden Age of Latin composition. The decline of Rome, both in intellect and morals, was becoming rapidly apparent. The splendid promise of the Augustan Age was quickly exhausted. The spirit of freedom evaporated under the influences of the time, and the spurious appearances which the emperor kept up had no power to impart real vigour to the national constitution. Just in the same manner it is abundantly clear that the fame of the age of Louis XIV. in France is founded on the excellence of the men who were actually born and bred in an earlier epoch and under a healthier régime. Neither the age of Augustus nor that of Louis produced the men who have rendered it illustrious. But the decline of Rome was becoming marked before the death of Augustus in other respects also. Although internal dissensions had been appeased, and private ambition quelled, the external relations of the empire were insecure, and caused vivid apprehensions. The frontiers

of the Rhine and Danube were constantly harassed by the indomitable spirit of the barbarians beyond them. On the Danube the Roman arms seem to have been crowned with a sufficient measure of success, but on the Rhine the great disaster of Varus, and the loss of three legions, left a deep impression of gloom upon the feelings of the age. Augustus himself suffered a succession of disappointments in the premature death of his nearest kindred, and in the loss of his trustiest advisers. Though he maintained to the last an outward serenity almost touching, he appears to have been painfully conscious of the substantial failure of the great pacification he had accomplished, and to have augured nothing but evil from the character of the stepson, to whom, at the last moment, he was content to leave his inheritance. A general foreboding of evil was creeping over the minds of his people. The age of Augustus, which lasted nearly fifty years, was indeed a long day even in the life of a nation, but its sun was manifestly hastening to its setting, and the night was coming, slowly, gradually, but surely.

(C. M.)

AUGUSTUS II. (also, and more accurately, designated *FREDERICK AUGUSTUS I.*), Elector of Saxony and King of Poland, second son of John George III. of Saxony, was born at Dresden, 12th May 1670. His personal beauty was remarkable, and from his great physical strength he received the surname of *The Strong*, by which he is commonly distinguished. He was very carefully educated, and spent several years travelling in Europe, visiting most of the courts, and taking part in some campaigns against the French. In 1694 he succeeded his elder brother as elector of Saxony, and shortly after, having entered into alliance with Austria, was appointed to the chief command of the imperial forces against the Turks. In 1697, after having suffered a defeat at Olasch, he resigned this office, and proceeding to Vienna, entered into negotiations with regard to the throne of Poland, left vacant by the death of John Sobieski in 1696. As a preliminary step in his candidature, Augustus renounced the Protestant faith, and proclaimed himself a Catholic. Among his rivals the most formidable was the French prince of Conti. Both expended enormous sums in buying over the Polish nobles, and both claimed to be elected at the general diet. Conti, however, was not on the spot, and Augustus, marching into Poland with his Saxon forces, gained possession of the kingdom. Scarcely was he settled on the throne, when he entered into alliance with Russia and Denmark against the young king of Sweden, and with his Saxon troops (for the Poles would not unite with him) invaded Livonia. In the campaigns which followed (1700-1704), he was completely worsted by the extraordinary military genius of his opponent, the celebrated Charles XII. of Sweden; he was driven from Poland, and Stanislaus Leszcynski was crowned in his place. The Swedes, following up their victories, invaded Saxony, and in 1706, at Altranstädt, Augustus was compelled to make peace, to repay the expenses of the Swedish army, to acknowledge Stanislaus as king of Poland, and to congratulate him on his accession. After these reverses he spent some time as a volunteer in the Netherlands, but the defeat of Charles at Pultowa (1709) again raised his hopes. He at once declared the Altranstädt treaty null and void, and having received promises of assistance from Russia, entered Poland, drove out Stanislaus, and was a second time proclaimed king. During the following years he continued to carry on the war with Sweden, while at the same time his kingdom was distracted by the jealousy with which the Poles regarded the Saxon troops, who were compelled to leave Poland in 1717. In 1718 Charles XII. was killed at Frederichshall, and from that time the reign of Augustus was marked by no important event. His court became celebrated as the



most extravagant and luxurious in Europe, and he himself as the most dissolute and magnificent of princes. His lavish expenditure, though it enriched his capital with treasures of art, impoverished both Poland and Saxony, and laid the foundations for the future misfortunes of those countries. He died, 1st February 1733, from mortification of an old wound. Of his numerous natural children, the most famous was the distinguished general, Maurice of Saxony.

**AUGUSTUS III.**, or **FREDERICK AUGUSTUS II.**, Elector of Saxony and King of Poland, only legitimate son of Augustus the Strong, was born at Dresden, 7th October 1696. He was brought up in the Protestant faith, but in 1712, while on his travels, he entered the Church of Rome, though his change of opinion was not publicly known till 1717. In 1733 he succeeded his father as elector of Saxony, and put forward claims to the kingdom of Poland. The Polish nobles, however, had become dissatisfied with foreign rule, and endeavoured to reinstate Stanislaus Lezajski, whose daughter was married to Louis XV. of France. Russia and Austria, probably bribed, but certainly dreading French influence in Poland, supported Augustus, who was elected, though in an informal manner, and by their aid established himself in the kingdom. On the death of Charles of Austria in 1740, Saxony at first joined the league against Maria Theresa, but jealousy of the Prussian successes in the first campaign caused Augustus to unite with the empress when war broke out a second time in 1744. His forces were completely defeated by Frederick, and Saxony was overrun and pillaged by the Prussian troops. Eleven years later Augustus joined the alliance against Frederick, which gave rise to the Seven Years' War. He was again unfortunate; the whole Saxon army was surrounded and compelled to surrender at Pirna in 1756, and during the remainder of the war Saxony and Poland were the seats of operations, and suffered severely. Augustus died 8th October 1763, surviving only by a few months the peace of Hubertsburg. During his reign considerable additions were made to the collections of art treasures formed by his father, and Dresden began to be celebrated throughout Europe for its china and pictures.

**AUK**, a name common to several species of sea-fowl belonging, with one exception, to the family *Alcidae*. Of these, special interest attaches to the Great Auk, or Garg-fowl (*Alca impennis*), from the circumstance that there is no authentic record of its having been taken, or even seen alive, for more than a quarter of a century. In the autumn of 1821 Dr Fleming, while on a cruise through the Hebrides, observed and described one which had been taken alive in the sea off St Kilda and put on board the yacht. With a rope attached to one of its legs, this specimen was occasionally allowed to disport itself in its native element, where it astonished every one by the rapidity with which it swam under water. On one of these occasions it got loose from its bonds, and was soon beyond reach of pursuit. Another specimen had been observed a few years before off Papa Westra, one of the Orkney Islands, but in spite of the exertions of the crew of a six-oared boat, continued for several hours, the auk could not be overtaken. This specimen, however, was afterwards secured, and is now in the British Museum. The Great Auk measures about three feet in length, has a large bill, but wings so small as to be totally useless for flying, serving, however, as powerful swimming organs. It is said to have laid a single egg on the bare rock,—usually, from the inability of the bird to rise on wing to the higher cliffs, close to the water edge. Its food, according to Fabricius, consisted of the lump-sucker and other fishes of a similar size. From the earliest existing accounts, the Great Auk does not appear to have ever been more than an occasional visitant to the British Isles, and then chiefly to the sea around St Kilda and the

Orkneys, while Iceland, the Faroes, and the islets about Newfoundland, appear to have been its proper home. The probability that this bird is now totally extinct gives special value to the remains of it now existing. These, according to Professor Newton, are as follows:—71 or 72 skins, 9 skeletons, 38 or 41 detached bones of different birds, and 65 eggs. The other Auks are the Puffin, the Razorbill, and the Little Auk, all widely distributed along the northern-temperate and Arctic coasts.

**AULIC COUNCIL** (from the Latin *aula*, a hall, in German, *Reichshofrath*), one of the two supreme courts of the old Germanic empire, the other being the imperial chamber (*Reichskammergericht*). It was called into existence in 1501 by the Emperor Maximilian, and was by him intended to counterbalance the influence of the imperial chamber, which he had been compelled to form by the states six years before. The Aulic Council had in many respects equal power with the chamber; from its decisions there was no appeal, and under its special jurisdiction were included the consideration of the imperial reserved rights, fees, and privileges, the settlement of disputes as to precedence among the several states, and the arrangement of matters relating to the Italian possessions of the empire. All questions of law could be submitted either to this council or to the chamber. The members were at first appointed by the emperor, at whose death the court dissolved, and new appointments were made by his successor. The power of the council increased under several of the emperors; it was formally recognised as coequal with the imperial chamber; and after the peace of Westphalia its organisation was altered so as to meet the requirements of the time. It then and afterwards consisted of a president, vice-president, and eighteen councillors, all selected and paid by the emperor, and of a vice-chancellor, whose appointment rested with the electorate of Mainz. Six members were Protestants, and the votes of these six, when unanimous, could not be overturned by any majority of the others. The councillors were divided into two parties—the first consisting of the counts and barons, the second of the men of learning, who possessed equal rights with the nobles, but were more highly paid. At the dissolution of the old Germanic imperial system in 1806, the Aulic Council in its former signification came to an end, though an Austrian court bearing the same title still continued to sit in Vienna.

**AULIS**, a town in Bœotia, supposed to have been situated on a rocky peninsula between two bays, about three miles S. of Chalcis. During the Trojan war it was the rendezvous of the Greek fleet, and has obtained celebrity as the scene of the sacrifice of Iphigenia. Pausanias states that in his day there was still to be seen here the temple of Artemis ascribed to Agamemnon.

**AUMALE**, formerly **ALBEMARLE**, from the Latin *Alba Marla*, a town of France, in the department of Seine Inférieure, on the banks of the Breule, 35 miles N.E. of Rouen. Grain and hemp are cultivated in the neighbourhood; cloth is manufactured; and the town has a trade in wool and cattle. Population, 2229. Aumale was erected by William the Conqueror into a countship, which was afterwards held in succession by the houses of Castile, Dammartin, Harcourt, and Lorraine; and in 1547 it was raised to the rank of a dukedom in favour of Francis of Lorraine. It afterwards passed to the house of Savoy, from whom it was purchased in 1675 by Louis XIV., who conferred it as an appanage on one of his natural sons. In 1769 it came into possession of the house of Orleans. The earl of Albemarle, in the British peerage, derives his title from Aumale.

**AUNGERVYLE**, **RICHARD**, commonly known by the name of *Richard de Bury*, was born in 1281, at Bury St

Edmund's in Suffolk, and educated at the university of Oxford. He entered the order of Benedictine monks, but was shortly afterwards appointed tutor to the prince of Wales. On the accession of his pupil to the throne as Edward III., he was promoted to various offices of dignity, and was finally made bishop of Durham, as well as lord high-chancellor and treasurer of England. He was several times engaged in embassies on the Continent, and became acquainted with many of the most eminent men of the time, particularly with the poet Petrarch. A portion of his correspondence with the latter has been preserved. At Oxford he founded a library for the use of the students, which he furnished with the best collection of books then in England, and appointed five keepers, to whom he granted yearly salaries. He died at his manor of Anokland, 24th April 1345, and was buried in the cathedral church of Durham. His works are—(1.) *Philobiblon*, containing directions for the management of his library at Oxford, and an elaborate eulogy of learning, written in very bad Latin,—first printed at Cologne 1473, then at Spire, 1483, and finally at Oxford, 1599; (2.) *Epistola Familiarum*, some of which are addressed to Petrarch; (3.) *Orationes ad Principes*, mentioned by Bals and Pita.

AJRAY, a small town of France, situated on the slope of a hill near the mouth of the river of the same name, in the department of Morbihan, 10 miles W. of Vannes. Its port is greatly frequented by coasting vessels; and it carries on a considerable industry in stocking-weaving, silk-spinning, tanning, shipbuilding, &c. The principal buildings are the church of St Esprit (13th century), which is now transformed into a college, the church of St Gildas, the town-house (17th century), and the Chartreuse, which marks the site of the battle of 1364, in which Charles of Blois was defeated by John de Montfort. In the neighbourhood is the church of Sainte Anne d'Auray, one of the principal places of pilgrimage in Brittany. Population, 4542. (See Palliser's *Brittany and its Byeways*, 1869.)

AURELIANUS, CÆLIUS, a celebrated Latin physician, born probably at Sioca in Numidia, but regarding whose life scarcely anything is known. The very date at which he flourished is quite uncertain. In his books he refers frequently to Soranus, and does not mention Galen, from which it has been inferred that he lived at a period intermediate between these two writers, i.e., during the 2d century A.D. But if the writings under his name are, as seems at least probable, translations or paraphrases from Soranus, the absence of any reference to Galen can easily be understood. Again, Galen does not mention Aurelianus, though he notices many minor physicians; from which fact, together with the corrupt Latin style of his extant works, it has been supposed by several authorities that the more correct date is the 5th century A.D. The writings of Aurelianus, which are composed from the point of view of the methodical school, and show considerable practical skill in the diagnosis of ordinary and even of exceptional diseases, consist of the following:—(1.) A treatise, in three books, on acute diseases (*Acutarum or Celorum Passionum*), Paris, 1533 and 1826. (2.) A treatise, in five books, on chronic diseases (*Tardarum or Chronicarum Passionum*), Basle, 1529. Both these treatises were published together in 1566, and frequently since. (3.) Fragments of a comprehensive treatise on medical science in the form of a dialogue (*Medicinalis Responsiones*), referred to in the preface to the work on acute diseases, have been discovered and published by Val. Rose in his *Anecdota Græca et Græco-Latina*, vol. ii. 1871.

AURELIUS ANTONINUS, MARCUS, the noblest of pagans, the crown and flower of Stoicism, was born at Rome 121 A.D., the date of his birth being variously stated as the

21st and the 26th April. His original name was Marcus Annius Verus. His father, Annius Verus, died while he was prætor; his mother, who survived her husband, was Domitia Calvilla or Lucilla. By both his parents he was of noble blood, his mother being a lady of consular rank, and his father claiming descent from Numa Pompilius. Marcus was an infant when his father died, and was thereupon adopted by his grandfather. The latter spared no pains upon his education, and the moral training which he received, both from his grandfather and from his mother, and to which he alludes in the most grateful and graceful terms in his *Meditations*, must have been all but perfect. The noble qualities of the child attracted the attention of the Emperor Hadrian, who, playing upon the name Verus, said that it should be changed to Verissimus. When Marcus reached the age of seventeen, Hadrian adopted, as his successor, Titus Antoninus Pius (who had married Annia Galeria Faustina, the sister of Annius Verus, and was consequently the uncle of Marcus), on condition that he in turn adopted both his nephew and Lucius Ceionius Commodus, the son of Ælius Cæsar, whom Hadrian, being childless, had originally intended as his successor, but who had died before him. It is generally believed that, had Marcus been old enough, Hadrian would have adopted him directly.

After the death of Hadrian, and the accession of Antoninus Pius to the throne, it became at once apparent that a distinguished future was in store for Marcus. He had been, at the age of fifteen, betrothed to the sister of Commodus; the engagement was broken off by the new emperor, and he was instead betrothed to Faustina, the daughter of the latter. In 139 A.D. the title of Cæsar was conferred upon him, and he dropped the name of Verus. The full name he then bore was Marcus Ælius Aurelius Antoninus, Ælius coming from Hadrian's family, and Aurelius being the original name of Antoninus Pius. He is generally known as Marcus Aurelius or Marcus Aurelius Antoninus. In 140 A.D. he was made consul, and entered fully upon public life.

The education of Aurelius in his youth was so minute, and has been so detailed by himself, that it ought not to be passed over without notice. Professor Long says, with perfect truth, apparently, of the trainers and the trained, "Such a body of teachers, distinguished by their acquirements and their character, will hardly be collected again, and as to the pupil we have not had one like him since." We have already alluded to the care bestowed upon him in youth by his mother and grandfather; a better guardian than that thoroughly good man and prudent ruler, Antoninus Pius, could not be conceived. Marcus himself says, "To the gods I am indebted for having good grandfathers, good parents, a good sister, good teachers, good associates, good kinsmen and friends, nearly everything good." He never attended any of the Roman public schools, and this he makes a matter for self-congratulation. He was trained by tutors, in whom, particularly in Rusticus, he appears to have been very fortunate, and to whom he showed gratitude when he reached the throne by raising them to the highest dignities of the state. Like most of the young Romans of the day, he began his studies with rhetoric and poetry, his teachers being Herodes Atticus and M. Cornelius Fronto. But, at the early age of eleven, he entered upon another course of study, in which he may be said to have continued more or less till the end of his life. He became acquainted with Diogenetus the Stoic, was fascinated by the philosophy he taught, assumed the dress of his sect, and ultimately abandoned rhetoric and poetry for philosophy and law, having among his teachers of the one Sextus of Chironæa, and of the other L. Volusianus Marcianus, a distinguished jurist. He went thoroughly and heartily into the practice as well as the

theory of Stoicism, and lived so abstemious and laborious a life, that he injured his health. It was from his Stoical teachers that he learned so many admirable lessons.—to work hard, to deny himself, to avoid listening to slander, to endure misfortunes, never to deviate from his purpose, to be grave without affectation, delicate in correcting others, “not frequently to say to any one, nor to write in a letter, that I have no leisure,” nor continually to excuse the neglect of ordinary duties by alleging urgent occupations. Through all his Stoical training, Aurelius preserved the natural sweetness of his nature, so that he emerged from it the most lovable as well as the saintliest of Pagans.

Antoninus Pius reigned from 138 to 161 A.D., and the concord between him and his destined heir was so complete, that it is recorded that during these twenty-three years Marcus never slept oftener than twice away from the house of Pius. It is generally believed that Aurelius married Faustina in 146, at all events a daughter was born to him in 147. The two noblest of imperial Romans were associated both in the administration of the state and in the simple country occupations and amusements of the sea-side villa of Lorium, the birthplace of Pius, to which he loved to retire from the pomp and the wretched intrigues of Rome.

Antoninus Pius died of fever, 161 A.D., at his villa of Lorium at the age of seventy-five. As his end approached, he summoned his friends and the leading men of Rome to his bedside, and recommended to them Marcus, who was then forty years of age, as his successor, without mentioning the name of Commodus, his other adopted son, commonly called Lucius Verus. It is believed that the senate agreed with what appeared to be the wishes of the dying emperor, and urged Aurelius to take the sole administration of the empire into his hands. But at the very commencement of his reign, Marcus showed the magnanimity of his nature by admitting Verus as his partner in the empire, giving him the tribunitian and proconsular powers, and the titles *Cæsar* and *Augustus*. This was the first time that Rome had two emperors as colleagues. Verus proved to be a weak, self-indulgent man; but he had a high respect for his adoptive brother, and deferred uniformly to his judgment. Although apparently ill-assorted, they lived in peace; and Verus married Lucilla, the daughter of Aurelius. In the first year of his reign Faustina gave birth to twins, one of whom survived to become the infamous Emperor Commodus.

The early part of the reign of Aurelius was clouded by various national misfortunes: an inundation of the Tiber swept away a large part of Rome, destroying fields, drowning cattle, and ultimately causing a famine; then came earthquakes, fires, and plagues of insects; and finally, the unruly and warlike Parthians resumed hostilities, and under their king, Vologeses, defeated a Roman army and devastated Syria. Verus, originally a man of considerable physical courage and even mental ability, went to oppose the Parthians, but, having escaped from the control of his colleague in the purple, he gave himself up entirely to sensual excesses, and the Roman cause in Armenia would have been lost, and the empire itself, perhaps, imperilled, had Verus not had under him able generals, the chief of whom was Avidius Cassius. By them the Roman prestige was vindicated, and the Parthian war brought to a conclusion in 165, the two emperors having a triumph for their victory in the year following. Verus and his army brought with them from the east a terrible pestilence, which spread through the whole empire, and added greatly to the horrors of the time. The people of Rome seem to have been completely unnerved by the universal distress, and to have thought that the last days of the empire had

come. Nor were their fears without cause. The Parthians had at the best been beaten, not subdued, the Britons threatened revolt, while signs appeared that various tribes beyond the Alps intended to break into Italy. Indeed, the bulk of the reign of Aurelius was spent in efforts to ward off from the empire the attacks of the barbarians. To allay the terrors of the Romans, he went himself to the wars with Verus, his headquarters being Carnuntum on the Danube. Ultimately, the Marcomanni, the fiercest of the tribes that inhabited the country between Illyria and the sources of the Danube, sued for peace in 168. The following year Verus died, having been, it is said, cut off by the pestilence which he had brought from Syria, although in that wicked age there were not wanting gossips malignant enough to say even of Marcus that he hastened his brother's death by poison.

Aurelius was thenceforth undisputed master of the Roman empire, during one of the most troubled periods of its history. Mr Farrar, in his *Seekers after God*, thus admirably describes the manner in which he discharged his multifarious duties:—“He regarded himself as being, in fact, the servant of all. It was his duty, like that of the bull in the herd, or the ram among the flocks, to confront every peril in his own person, to be foremost in all the hardships of war, and most deeply immersed in all the toils of peace. The registry of the citizens, the suppression of litigation, the elevation of public morals, the care of minors, the retrenchment of public expenses, the limitation of gladiatorial games and shows, the care of roads, the restoration of senatorial privileges, the appointment of none but worthy magistrates, even the regulation of street traffic, these and numberless other duties so completely absorbed his attention, that, in spite of indifferent health, they often kept him at severe labour from early morning till long after midnight. His position, indeed, often necessitated his presence at games and shows, but on these occasions he occupied himself either in reading, in being read to, or in writing notes. He was one of those who held that nothing should be done hastily, and that few crimes were worse than the waste of time.”

Peace was not long allowed the emperor. The year after the death of his partner, two of the German tribes, the Quadi and the Marcomanni, renewed hostilities with Rome, and, for three years, Aurelius resided almost constantly at Carnuntum, that he might effectually watch them. In the end, the Marcomanni were driven out of Pannonia, and were almost destroyed in their retreat across the Danube. In 174 Aurelius gained a decisive victory over the Quadi, to which a superstitious interest is attached, and which is commemorated by one of the sculptures on the Column of Antonine. The story is that the Roman army had been entangled in a defile, from which they were unable to extricate themselves, while at the same time they suffered intensely from thirst. In this extremity a sudden storm gave them abundance of rain, while the hail and thunder which accompanied the rain confounded their enemies, and enabled the Romans to gain an easy and complete victory. This triumph was universally considered at the time, and for long afterwards, to have been a miracle, and bore the title of “The Miracle of the Thundering Legion.” The Gentile writers of the period ascribed the victory to their gods, while the Christians attributed it to the prayers of their brethren in a legion to which, they affirmed, the emperor then gave the name of Thundering. *Dacier*, however, and others who adhere to the Christian view of the miracle, admit that the appellation of Thundering or Lightning (*κεραυνοβόλος*, or *κεραυνοφόρος*) was not given to the legion because the Quadi were struck with lightning, but because there was a figure of lightning on their shields. It has also been

virtually proved that it had the title even in the reign of Augustus.

Even after this Aurelius was not allowed to rest. From Rome, to which he had returned, he marched to Germany to carry on the war against the tribes which harassed the empire. There the alarming news reached him that Avidius Cassius, the brave and experienced commander of the Roman troops in Asia, had revolted and proclaimed himself emperor. But the rebellion did not last long. Cassius had only enjoyed his self-conferred honour for three months, when he was assassinated, and his head was brought to Marcus. With characteristic magnanimity, Marcus did not thank the assassins for what they had done; on the contrary, he begged the senate to pardon all the family of Cassius, and to allow his life to be the only one forfeited on account of the civil war. This was agreed to, and it must be considered as a proof of the wisdom of Aurelius's clemency, that he had little or no trouble in pacifying the provinces which had been the scene of rebellion. He treated them all with forbearance, and it is said that when he arrived in Syria, and the correspondence of Cassius was brought him, he burnt it without reading it. During this journey of pacification his wife Faustina, who had borne him eleven children, died. The gossiping historians of the time, particularly Dion Cassius and Capitolinus, charge Faustina with the most shameless infidelity to her husband, who is even blamed for not paying heed to her crimes. But none of these stories rest on evidence which can fairly be considered trustworthy; while, on the other hand, there can be no doubt whatever that Aurelius loved his wife tenderly, and trusted her implicitly while she lived, and mourned deeply for her loss. It would seem that Aurelius, after the death of Faustina and the pacification of Syria, proceeded, on his return to Italy, through Athens, and was initiated in the Eleusinian mysteries, the reason assigned for his doing so being, that it was his custom to conform to the established rites of any country in which he happened to find himself. Along with his son Commodus he entered Rome in 176, and obtained a triumph for victories in Germany. In 177 occurred that persecution of Christians, the share of Aurelius in which has caused great difference of opinion, and during which Attalus and others were put to death. Meanwhile the war on the German frontier continued, and the hostile tribes were defeated as on former occasions. In this campaign Aurelius led his own forces; and, probably on that account, he was attacked by some infectious disease, which ultimately cut him off, after a short illness, according to one account, in his camp at Sirmium (Mitrovitz) on the Save, in Lower Pannonia, and, according to another, at Vindobona (Vienna), on the 17th March 180 A.D., in the fifty-ninth year of his age. His ashes (according to some authorities, his body) were taken to Rome, and he was deified. Those who could afford the cost obtained his statue or bust, and, for a long time, statues of him held a place among the Penates of the Romans. Commodus, who was with his father when he died, erected to his memory the Antonine Column (now in the Piazza Colonna at Rome), round the shaft of which are sculptures in relief commemorating the miracle of the Thundering Legion and the various victories of Aurelius over the Quadi and the Marcomanni.

The one blemish in the life of Aurelius is his hostility to Christianity, which is the more remarkable that his morality comes nearer than any other heathen system to that of the New Testament. Attempts have been made to show that he was not responsible for the atrocities with which his reign is credited, but the evidence of Justin, of Athenagoras, of Apollinaris, and above all, of Melito, bishop of Sardis, and of the Church of Smyrna, is overwhelmingly

to the effect that not only were there severe persecutions of Christians, in which men like Polycarp and Justin perished, but that the foundation of these persecutions was certain rescripts or constitutions issued by Aurelius as supplementary to the milder decrees of his predecessors Hadrian and Antoninus Pius. In explanation, however, if not in extenuation, of the attitude of Aurelius towards Christianity, several circumstances should be taken into consideration. In the first place, it is evident that he knew little of the Christians, and absolutely nothing of Christian ethics. In his *Meditations* he makes only one reference (xi. 3) to the adherents of the new creed, and that of the most contemptuous character, showing that he confounded them all with certain fanatics of their number, whom even Clemens of Alexandria compares, on account of their thirst for martyrdom, to the Indian gymnosophists. How far this ignorance was culpable it is impossible at so remote a date to say. Further, it should be noted, in regard to the rescripts upon which the persecutions were founded, that, although they were in the name of the emperor, they may not have proceeded directly from him. There is no evidence that he was an active persecutor, except a passage in Orocius to the effect that there were persecutions of the Christians in Asia and Gallia "under the orders of Marcus;" and it should not be kept out of consideration that he was to some extent a constitutional monarch, and had to pay deference both to the *consulta* of the senate and the precedents of previous emperors. At the time there was a great popular outcry against the Christians on social and political, even more than on religious, grounds; and Aurelius may have been as much at the mercy of intriguers or fanatics when he gave his sanction to the butcheries of Christians in Asia Minor, as William III. was at the mercy of Stair and Breadalbane, the real authors of the massacre of Glencoe. Finally, it should be borne in mind that, in the reign of Aurelius, the Christians had assumed a much bolder attitude than they had hitherto done. Not only had they caused first interest and then alarm by the rapid increase of their numbers, but, not content with a bare toleration in the empire, they declared war against all heathen rites, and, at least indirectly, against the Government which permitted them to exist. In the eyes of Aurelius they were atheists and foes of that social order which he considered it the first of a citizen's duties to maintain, and it is quite possible that, although the most amiable of men and of rulers, he may have conceived it to be his duty to sanction measures for the extermination of such wretches. Still his action at the time must be considered, as John Stuart Mill puts it, as "one of the most tragical facts in all history."

The book which contains the philosophy of Aurelius is known by the title of his *Reflections*, or his *Meditations*, although that is not the name which he gave to it himself, and of the genuineness of the authorship no doubts are now entertained. It is believed that the emperor also wrote an autobiography, which has perished with other treasures of antiquity. The *Meditations* were written, it is evident, as occasion offered,—in the midst of public business, and even on the eve of battles on which the fate of the empire depended,—hence their fragmentary appearance, but hence also much of their practical value and even of their charm. It is believed by many critics that they were intended for the guidance in life of Aurelius's son, Commodus. If so, history records how lamentably they failed in accomplishing their immediate effect, for Commodus proved one of the greatest sensualists, buffoons, and tyrants that disgraced even the Roman purple. But they have been considered as one of the most precious of the legacies of antiquity,—as, in fact, the best of non-inspired reflections on practical morality. They have been recognised as among the most effectual stimuli to struggles

in life, of whatever class and in whatever position, in the field of speculation as in that of action. The *Meditations* of Marcus Aurelius were, with Machiavelli's *Art of War*, the daily study of Captain John Smith, the real founder of the United States. They are placed by Mr Mill in his posthumous essay on the *Utility of Religion* as almost equal in ethical elevation to the Sermon on the Mount.

Aurelius early embraced, and throughout life adhered to, the Stoical philosophy, probably because he considered it as the sternest and most solid system to oppose to the corruption of his time. But, as Tenneman says, he imparted to it "a character of gentleness and benevolence, by making it subordinate to a love of mankind, allied to religion." In the *Meditations* it is difficult to discover anything like a systematic philosophy, which, indeed, means, as he used the word, tranquillity, or a serene habit of mind. From the manner, however, in which he seeks to distinguish between matter (*σῶμα*) and cause or reason (*αἰτία, λόγος*), and from the Carlylean earnestness with which he advises men to examine all the impressions on their minds (*φαντασίαι*), it may be inferred that he held the view of Anaxagoras—that God and matter exist independently, but that God governs matter. There can be no doubt that Aurelius believed in a deity, although Schultz is probably right in maintaining that all his theology amounts to this,—the soul of man is most intimately united to his body, and together they make one animal which we call man; and so the deity is most intimately united to the world or the material universe, and together they form one whole. We find in the *Meditations* no speculations on the absolute nature of the deity, and no clear expressions of opinion as to a future state. We may also observe here that, like Epictetus, he is by no means so decided on the subject of suicide as the older Stoics. Aurelius is, above all things, a practical moralist. The goal in life to be aimed at, according to him, is not happiness, but tranquillity, or equanimity. This condition of mind can be attained only by "living conformably to nature," that is to say, one's whole nature, and as a means to that, man must cultivate the four chief virtues, each of which has its distinct sphere—wisdom, or the knowledge of good and evil; justice, or the giving to every man his due; fortitude, or the enduring of labour and pain; and temperance, or moderation in all things. It is no "fugitive and cloistered virtue" that Aurelius seeks to encourage; on the contrary, man must lead the "life of the social animal," must "live as on a mountain;" and "he is an abcess on the universe who withdraws and separates himself from the reason of our common nature through being displeased with the things which happen." While the prime principle in man is the social, "the next in order is not to yield to the persuasions of the body, when they are not conformable to the rational principle which must govern." This "divinity within a man," this "legislating faculty" (*τὸ θεμιονεύον*) which, looked at from one point of view, is conscience, and from another is reason, must be implicitly obeyed. He who thus obeys it will attain tranquillity of mind; nothing can irritate him, for everything is according to nature, and death itself "is such as generation is, a mystery of nature, a composition out of the same elements, and a decomposition into the same, and altogether not a thing of which any man should be ashamed, for it is not contrary to the nature of a reasonable animal, and not contrary to the reason of our constitution."

The morality of Marcus Aurelius cannot be said to have been new when it was given to the world, far less can it be said to be systematic. Compared, indeed, with elaborate treatises on ethics, the *Meditations* of Marcus Aurelius are as tonic medicine to succulent food. The

charm of his morality lies in its exalted accent and its infinite tenderness. Where can the connoisseur in morals find anything finer than such sentences as this?—"The pride which is proud of its want of pride is the most intolerable of all;" or where can a more delicate rebuke to the Pharisaism which lurks in the breast of every man be obtained than this?—"One man, when he has done a service to another, is ready to set it down to his account as a favour conferred. Another is not ready to do this, but still, in his own mind, he thinks of the man as his debtor, and he knows what he has done. A third in a manner does not even know what he has done, but he is like a vine which has produced grapes, and seeks for nothing more after it has once produced its proper fruit. So a man when he has done a good act, does not call out for others to come and see, but he goes on to another act as a vine goes on to produce again the grapes in season." But above all, what gives the sentences of Marcus Aurelius their enduring value and fascination, what renders them superior to the utterances of other moralists of the same school, such as Epictetus and Seneca, is that they are the gospel of his life. His practice was in accordance with his precepts, or rather his precepts are simply the records of his practice. To the saintliness of the cloister he added the wisdom of the man of the world; constant in misfortune, not elated by prosperity, never "carrying things to the sweating point;" preserving, in a time of universal corruption, unreality, and self-indulgence, a nature sweet, pure, self-denying, unaffected, Marcus Aurelius has given to the world one of the finest examples of the possibilities of humanity.

The *Meditations* of Marcus Aurelius have been translated into English, German, French, Spanish, and Italian. The two chief English translations are those of Jeremy Collier (1702) and of George Long; the last may be considered final. The text most commonly used is the Greek one edited by J. M. Schultz (republished by Tauchnitz in 1821). Many books have been written on the life and times of Aurelius, and the essays on his *Meditations* are innumerable. One of the best estimates of him is contained in Mr F. W. Farrar's *Seekers after God*, 1868. A scholarly work issued in 1874 by M. Gaston Boissin, entitled *La Religion Romaine d'Auguste aux Antonines*, gives, perhaps, the most interesting existing account of the state of society under the Antonines.

AUREOLA, AUREOLE, the radiance or luminous cloud which, in paintings of sacred personages, is represented as surrounding the whole figure. In the earliest periods of Christian art this splendour was confined to the figures of the persons of the Godhead, but it was afterwards extended to the Virgin Mary and to several of the saints. The aureole, when enveloping the whole body, is generally oval or elliptical in form, but is occasionally circular or quatrefoil. When it is merely a luminous disk round the head, it is called specifically a *nimbus*, while the combination of nimbus and aureole is called a *glory*. The strict distinction between nimbus and aureole is not commonly maintained, and the latter term is most frequently used to denote the radiance round the heads of saints, angels, or persons of the Godhead.

AURICH, a town of Prussia, in the province of Hanover, situated on the Treckief canal. It is regularly built; possesses a castle, which was formerly the residence of the prince of East Friesland, a lyceum, and four libraries; and carries on the manufacture of leather, paper, pottery, and tobacco. The famous meeting-place of the East Frislanders, *Upstaalboom*, is in the neighbourhood. Population, 4264.

AURIFABER (the Latinised form of the name GOLDSCHMIDT), JOHANNES, a Lutheran divine, celebrated as the

friend of Luther and as one of the editors of his works, was born in 1519 in the county of Mansfeldt, or, more probably, in the town of Weimar. After completing his education at the university of Wittenberg, where he heard the lectures of Luther, he became tutor to Count Mansfeldt, and in the war of '54-5 accompanied the army as field-preacher. For some months afterwards he resided with Luther as his *famulus* or private secretary, and was present at his death in 1546. In the following year he spent six months in prison along with John Frederick, elector of Saxony, who had been captured by the emperor, Charles V. He held for some years the office of court-preacher at Weimar, but, owing to theological disputes, was compelled to resign this office in 1561. In 1566 he was appointed to the Lutheran church at Erfurt, which post he held, though not without serious differences with his fellow-clergymen, till his death in 1575. Besides taking a share in the first collected or Jena edition of Luther's works, Aurifaber sought out and published at Eisleben in 1564-5 several writings not included in that edition. He also published Luther's *Letters* (1556, 1565), and *Table Talk* (1566).

AURIFABER, JOANNES, a Lutheran divine, born at Breslau in 1517. He was educated at Wittenberg, and was there specially attracted to Melancthon, with whom he ever afterwards remained on terms of close friendship. After graduating in 1538 he spent twelve years as *docent* at the university, and having then received his doctorate of divinity, was appointed professor of divinity and pastor of the church of St Nicholas at Rostock. He distinguished himself by his prudence and conciliatory disposition, took a leading part in the composition of the regulations for the Mecklenburg Church, and was successful in allay-

ing some religious disputes in the town of Lübeck. The Grand-duke Albert of Prussia, who was very desirous of healing the differences in the Prussian Church caused by the discussion of Osiander's doctrines, was attracted by Aurifaber, invited him to Königsberg in 1553, and in the following year appointed him to the professorship of divinity in that university, and to the presidency of the Samland diocese. Aurifaber, however, found it impossible to conciliate all parties, and in 1565 returned to Breslau, where, for the three remaining years of his life, he discharged the joint offices of pastor in the church of St Elizabeth and director of the Lutheran Church and schools. He died 19th October 1568.

AURILLAC, the capital of the department of Cantal, France, situated on the right bank of the Jourdanne, which is here crossed by a handsome bridge. It contains tribunals of primary instance and commerce, a communal college, societies of agriculture, arts, and commerce, a public library, and a museum. Most of the town is of comparatively modern construction, its more ancient buildings having suffered severely in the religious wars of the 16th century. Of highest claims to antiquity are portions of the castle of St Etienne, the church of St Gérard, and a Benedictine abbey, which is regarded by many as the original nucleus round which Aurillac gathered. There is a statue of Sylvester II, who was a native of the town, and was educated in the abbey, which soon afterwards became one of the most famous schools of France. The manufactures consist of tapestry, lace, cutlery, paper, leather, &c., and a considerable number of horses are bred. Population in 1872, 11,098.

AURORA, the Roman personification of the dawn of day, corresponding to the Greek goddess Eos (q.v.)

## A U R O R A P O L A R I S

AURORA POLARIS, AURORA BOREALIS and AUSTRALIS, POLAR LIGHT, NORTHERN LIGHTS, or STREAMERS, an electrical meteor, appearing most frequently in high latitudes, in the form of luminous clouds, arches, and rays, of which the latter sometimes meet at a point near the zenith, and form what is called a *boreal crown*. The arches are sometimes single; sometimes several concentric ones are seen, and they are usually nearly stationary, or move slowly southward. They cross the magnetic meridian at right angles, and, therefore, in England, have their centres nearly N.N.W. The rays rise perpendicularly from the arches, but are sometimes seen detached, or when the arch is below the horizon. They are parallel to the dipping needle, or, in other words, to the curves of magnetic force; and the boreal crown, at which they appear to meet, is merely an effect of perspective. This point is in England about 70° in altitude, and nearly S.S.E. of the zenith. The rays are seldom stationary, but appear and disappear suddenly, shooting with great velocity up to the zenith, and moving slowly eastward or westward, but most commonly the latter. They sometimes cover the whole sky, and frequently have a strong tremulous motion from end to end. This tremulous motion is sometimes seen also in the arches when near the zenith; and Benjamin V. Marsh mentions a case in which the matter of the arch had the appearance of a rapid torrent flowing from east to west. A rare form of aurora is that in which the rays appear to hang from the sky like fringes or the folds of a mantle. The ordinary colour of the aurora is a pale greenish-yellow, but crimson, violet, and steel-colour are not uncommon. Crimson auroras have often been imagined by the superstitious to be omens of war, pestilence, and famine; and lively imaginations have seen in their motions—

"Fierce fiery warriors fight upon the clouds  
In ranks, and squadrons, and right form of war."

They were called by the ancients *chasmata*, *bolides*, and *trabes*, according to their forms and colours. In Shetland, where they are very frequent, and in the north of Scotland, they are known as the "*merry dancers*" (perhaps the ancient *capra saltantes*); while, from a curious passage in Sirr's *Ceylon and the Cingales*, vol. ii. p. 117, it seems that the aurora, or something like it, is occasionally visible in Ceylon, and that the natives call it the *Buddha lights*. Mr Jansen says, however, that the great aurora of 4th February 1872, which was seen at Bombay, was not visible in Ceylon. In many parts of Ireland a scarlet aurora is supposed to be a shower of blood, and under this name is not unfrequently mentioned in the old annals, always in connection with some battle or the murder of a great chief. The earliest mentioned was in 688, in the *Annals of Cloon-mac-noise*, after a battle between Leinster and Munster, in which Foylcher O'Moyloyer was slain. It was observed at Edessa in 502, and in Syria in 1097, 1098, and 1117.

The only thing resembling a distinct history of this phenomenon is that which has been given by Dr Halley, in the *Philosophical Transactions*, No. 347. The first account he gives, taken from a book entitled *A Description of Meteors*, by W. F., D.D., reprinted at London in 1654, describes the appearance of what is called by him *burning spears*, which were seen at London on the 30th January 1560. The next appearance, according to the testimony of Stow, was on the 7th October 1564. In 1574 also, according to Camden and Stow, an aurora borealis was observed two nights successively, viz., on the 14th and 15th of November, having much the same appearance as that described by Dr Halley in 1716. Again, an aurora

was twice seen in Brabant, in the year 1575, viz., on the 13th of February and 28th of September. Both appearances were described by Cornelius Gemm, professor of medicine at Louvain, who compares them to spears, fortified cities, and armies fighting in the air. Michael Mæstlin, tutor to Kepler, states that at Becknang in Würtemberg these phenomena, which he styles *chasmata*, were seen by himself no less than seven times in 1580. In 1581 they again appeared in great splendour in April and September, and in a less degree in some other months of the same year. In September 1621, a similar phenomenon was observed all over France, and described by Gassendi, who gave it the name of *aurora borealis*; yet neither this, nor any similar appearance posterior to 1574, is described by English writers till the year 1707. From 1621 to 1707, indeed, there is no mention made of an *aurora borealis* having been seen at all; and, considering the number of astronomers who during that period were continually scanning the heavens, it might almost be supposed that nothing of the kind really made its appearance until after an interval of eighty-six years. A small one was seen in November 1707; and during that and the following year the same appearances were repeated five times. The next on record is that mentioned by Dr Halley in March 1716, which from its brilliancy attracted universal attention, and was considered by the common people as marking the introduction of a foreign race of princes. Since that time these meteors have been much more frequent, and most of our readers must have seen the brilliant displays within the last few years which have been visible over the whole of Europe.

One singular phenomenon which seems to be connected with the aurora is that of a dark bank of cloud below the arches, and usually just above the northern horizon. Although this appears decidedly darker than the uncovered portion of the sky, it is of so thin a character that stars can be seen through it, as well as through the auroral arches and rays, with but little diminution of brightness. It is, however, quite possible that this cloud is only the somewhat misty open sky near the horizon, which appears darker by contrast with the bright arch above it.

It has been repeatedly affirmed that cracking, hissing, or whizzing sounds have been heard proceeding from the polar lights, and the natives of high latitudes are almost unanimous in alleging that this is sometimes the case. Scoresby, Richardson, Franklin, Parry, Hood, and later observers seem to have listened in vain for such noises, and it seems that in the intense cold of the Arctic night the contraction of the ice, or its cleavage under the pressure of approaching tempests, produces sounds exactly such as are described. Still, mere negative evidence must be received with caution, and it is very possible that in high latitudes such sounds may occasionally be heard, since the electric discharge seems to originate near the poles. The aurora, too, seems to vary greatly in height, and in lower latitudes is usually at such an altitude that audible sounds from it are quite impossible. Muschenbroeck says that the Greenland fishers in his time assured him that they had frequently heard noises proceeding from the *aurora borealis*, and his testimony is confirmed by that of many others. There is no *a priori* improbability of such sounds being occasionally heard, since a somewhat similar phenomenon accompanies the brush discharge of the electric machine, to which the aurora bears considerable resemblance.

Numerous observers (*Nature*, iv. 27, 47) have attested the occasional visibility of aurora by daylight. In the *Transactions of the Royal Irish Academy*, 1788, Dr H. Usher notices that aurora makes the stars "flutter" very much in the telescope, and states that, having noticed this effect strongly one day at 11 A.M., he examined the sky, and

saw an auroral corona with rays to the horizon. J. Glaisher, Franklin, and others, have also observed the phenomenon. It is scarcely possible that a light so faint as not even to obscure the stars should be visible in sunlight, and such facts would seem to suggest that the auroral light is developed in cloud or mist of some sort, which may become visible by reflected light, as well as by its own. Franklin says, "Upon one occasion the aurora was seen immediately after sunset, while bright daylight was still remaining. A circumstance to which I attach some importance must not be omitted. Clouds have sometimes been observed during the day to assume the forms of aurora, and I am inclined to connect with these clouds the deviation of the needle, which was occasionally remarked at such times." The writer has seen aurora which could not be distinguished from clouds, till the further development of the display made their real nature evident. Dr Richardson thinks he has observed a polarity in the masses of cloud belonging to a certain kind of cirro-stratus approaching to cirrus, by which their long diameters, having all the same direction, were made to cross the magnetic meridian nearly at right angles. But the apparent convergence of such masses of cloud towards the opposite points of the horizon, which have been so frequently noticed by meteorologists, is an optical deception, produced when they are situated in a plane parallel to that on which the observer stands. These circumstances, says Dr Richardson, are here noticed, because if it shall hereafter be proved that the aurora depends upon the existence of certain clouds, its apparent polarity may, perhaps, with more propriety, be ascribed to the clouds themselves which emit the light; or, in other words, the clouds may assume their peculiar arrangement through the operation of one cause (magnetism, for example), while the emission of light may be produced by another, namely, a change in their internal constitution, perhaps connected with a motion of the electrical fluid. D. Low (*Nat.*, iv. 121) states that he has witnessed as complete a display of auroral motions in the cirrus cloud as he ever beheld in a midnight sky. He thinks that all clouds are subject to magnetic or diamagnetic polarisation, and states that when the lines converge towards the magnetic pole, fine weather follows; when they are at right angles to this position, wet and stormy. The aurora appears in these latitudes usually to occur at a height much greater than that of ordinary clouds. Dr Richardson's observations (Franklin and Richardson's *Journey to the Shores of the Polar Sea*) seem to show, however, that, in the Arctic regions, the aurora is occasionally seated in a region of the atmosphere below a kind of cloud which is known to possess no great altitude, namely, that modification of cirro-stratus which, descending low in the atmosphere, produces a hazy sheet of cloud over head, or a fogbank in the horizon. Indeed, Dr Richardson is inclined to infer that the *aurora borealis* is constantly accompanied by, or immediately precedes, the formation of one or other of the forms of cirro-stratus. On the 13th of November and 18th December 1826, at Fort Enterprise, its connection with a cloud intermediate between cirrus and cirro-stratus is mentioned; but the most vivid coruscations of the aurora were observed when there were only a few thin attenuated shoots of cirro-stratus floating in the air, or when that cloud was so rare that its existence was only known by the production of a halo round the moon. The natives of the Arctic regions of North America pretend to foretell wind by the rapidity of the motions of the aurora; and they say that when it spreads over the sky in a uniform sheet of light, it is followed by fine weather, and that the changes thus indicated are more or less speedy, according as the appearance of the meteor is early or late in the evening,—an opinion not improbable, when it is recollected

that certain kinds of cirro-stratus are also regarded by meteorologists as sure indications of rain and wind. Dr Richardson frequently observed the lower surface of nebulous masses illuminated by polar lights,—a fact illustrative of the comparatively low situation of these aurora. Biot, also, in the island of Unst, observed many aurora that could not be higher than the region of clouds. Sir John Franklin in like manner observed low aurora. "The important fact," says he, "of the existence of the aurora at a less elevation than that of dense clouds was evinced on two or three occasions this night (13th February 1821, at Fort Enterprise), and particularly at 11 hours 50 min., when a brilliant mass of light, variegated with the prismatic colours, passed between a uniform steady dense cloud and the earth, and in its progress completely concealed that portion of the cloud which the stream of light covered, until the coruscation had passed over it, when the cloud appeared as before." Captain Parry, as stated in his third voyage, observed aurora near to the earth's surface. It is said that while Lieutenants Scherer and Ross and Captain Parry were admiring the extreme beauty of a polar light, they all simultaneously uttered an exclamation of surprise at seeing a bright ray of the aurora shoot suddenly downward from the general mass of light, and between them and the land, which was only 3000 yards distant. The ray or beam of the polar light thus passed within a distance of 3000 yards, or less than 2 miles, of them. Further, Mr Farquharson observed in Aberdeenshire an aurora borealis not more than 4000 feet above the level of the sea. Fitzroy believed that aurora in northern latitudes indicates and accompanies stormy weather at a distance, and that straining and cracking of the ice may cause the hissing and whizzing sounds.

M. Silbermann (*Comptes Rendus*, lxxviii. p. 1051) notes facts which strongly confirm the connection of aurora with some form of cirrus cloud. He says (of the aurora of 15th April 1869),—"At 11 hours 16 min. the phenomena disappeared in a singular fashion. It appeared as if the columns of the aurora were still visible, but the stars were hidden, and it soon became obvious that fan-like cirrus clouds, with their point of divergence in the north, had taken the place of the aurora. Between 1 and 2 in the morning these clouds had passed the zenith, and let fall a very fine rain. On stretching out the back of the hand one felt a pricking of cold, and now and then there were minute scintillations in the nearest strata of air, like a hail of tiny crystals of ice, which afterwards turned to a rain of larger and larger drops. At 4 o'clock in the morning the cirrus of the false aurora was still visible, but deformed towards the top, and presenting a flaky aspect. One interesting point is, that the cirrus never appeared to replace the aurora either from the right or the left, but to substitute itself for it, like the slow changes of a dioramic view." "I had previously observed a fall of small ice crystals on the 30th April 1865. At 6 P.M. Paris seemed enveloped in a cirrus of vertical fibres, recalling those of amianthus, and more or less wavy. It was a rain of little sparkling prisms. At the same time I heard a rustling or crepitation, and on extending my hand I felt a pricking sensation of cold, and distinguished the crystals which fell and melted immediately."

In a later memoir (*Ibid.*, p. 1120) he remarks that many storm-clouds throw out tufts of cirri from their tops, which extend over a great portion of the sky, and resolve themselves into a very fine and cold drizzle, which frequently degenerates into a warmer and more abundant rain. Usually the fibres are more or less sinuous, but in much rarer cases they become perfectly rectilinear, and surround the cloud like a glory, and occasionally shine with a sort of phosphorescence. As an illustration he quotes his obser-

vations on the night of the 6th September 1865:—"A stormy cloud was observed about 11 P.M. in the N.N.W., and lightning was distinctly visible in the dark cumulous mass. Around this mass extended glories of a phosphorescent whiteness, which melted away into the darkness of the starry sky. Round the cloud was a single and uninterrupted corona, and outside this, two fainter coronae broken by rifts which corresponded with each other. After the cloud had sunk below the horizon the glories were still visible. The light could not have been due to the moon or any foreign cause. The rays showed great mobility, and a sort of vibration intermediate between that of the aurora and the 'brush discharge' of the electric machine." He goes on to say that—

"Luminous clouds have been frequently observed. There are many examples in Gilbert's *Assays*, and we may recall also the observations of Becaria, Deluc, the Abbé Rozier, Nicholson, and Colla. Mists also are occasionally luminous, as, for instance, that observed by Dr Verdeil at Lausanne in 1763, and by Dr Robinson in Ireland."

A still more curious fact is mentioned by Sabine, who, during his magnetic survey, anchored some days at Loch Scavaig in Skye. This loch is surrounded by high and bare mountains, one of which was nearly always enveloped in a cloud, resulting from the vapours which almost constant west winds brought from the Atlantic. This cloud at nights was permanently self-luminous, and Sabine frequently saw rays similar to those of the aurora. He entirely repudiates the idea that the rays could be due to aurora beyond the mountain, and is sure that these phenomena, whatever their nature, were produced in the cloud itself.

Silbermann asserts that aurora are preceded by the same general phenomena as thunderstorms, and concludes that everything had happened as if the aurora of 1859 and 1869 had been storm-clouds, which, instead of bursting in thunder, had been drawn into the upper parts of the atmosphere, and their vapour being crystallised in tiny prisms by the intense cold, the electricity had become luminous in flowing over these icy particles. This view is very strongly supported by the observation of Professor Piazzi Smyth that the monthly frequency of aurora varies inversely with that of thunderstorms. The following are his numbers of relative frequency, the means of all observations of the Scottish Meteorological Society prior to 1871:—

	Lightning.	Aurora.
January.....	24.0	29.7
February.....	14.4	49.5
March.....	7.0	35.0
April.....	15.4	27.5
May.....	37.4	4.8
June.....	48.0	0.0
July.....	53.2	0.5
August.....	38.4	12.6
September.....	22.4	36.6
October.....	20.8	49.4
November.....	15.0	32.4
December.....	15.0	33.8
Mean of whole year...	24.0	20.1

It must, however, be remembered that the observed frequency of aurora is much affected in Scotland by the continuous twilight during the summer months. If there be this connection between thunder-clouds and aurora, it is not improbable that the "dark segment" is sometimes a real cloud or mist, situated at a height where the density of the air is too great for luminous discharge; and in several cases Silbermann has seen auroral rays rise from small clouds, which gradually melted entirely away, or left a small non-luminous nucleus when their electricity was discharged.

If, as would certainly be the case in a mist, any portion



of the auroral light is reflected, whether it be its own or derived from some other body, it should be polarised; but so far polariscope observations are deficient, and give no certain information. It is difficult to separate the proper polarisation of the aurora from the mere atmospheric polarisation of the sky. Mr Banyard, who appears to have used a double-imaged prism and Savart during the great aurora of Feb. 4, 1872, and also to have made some observations on that of Nov. 11, 1871, did not detect polarisation. On the other hand, Prof. Stephan Alexander, in his report on his expedition to Labrador (App. 21, *U. S. Coast Survey Rep.*, 1860), found strong polarisation with a Savart, and, singularly enough, thought it strongest in the dark parts of the aurora. The observations were made in lat. about 60°, in the beginning of July, and near midnight, but he does not state whether there was twilight or any trace of air polarisation at the time, nor does he give the plane of polarisation.

With regard to the height of auroras, Sir W. R. Grove (*Nature*, vol. iii. p. 28) states that he saw an aurora some years ago at Chester in which the rays came between him and the houses; and Mr Ledd observed a similar case in which the lighthouse at Margate was visible through a ray. The evidence, however, appears strong that aurora is usually at a very great height. Dalton calculated the height of an auroral arch, which was seen as far north as Edinburgh, and as far south as Doncaster, and at most intermediate places, from its apparent altitude, as measured by its position in relation to the stars as seen from Kendal and Warrington, 83 miles apart. The resulting height was about 100 miles, and the position slightly south of Kendal. An observation at Jedburgh confirmed this, but some taken at Edinburgh placed it above Carlisle at a height of 150 miles. Dalton, however, considered the former reckoning the more trustworthy. Backhouse has made many calculations, and considers that the average height of aurora ranges from 50 to 100 miles, and numerous other observers have calculated similar heights. All these observations, however, are liable to the objection, that different observers may really have seen different arches, of which, as has been remarked, there are often several concentric ones. It is not likely that this was really the case in most instances, but it has, no doubt, sometimes occurred, and may account for the heights of 500 to 1000 miles calculated by early observers. This difficulty is met by a method proposed by Prof. H. A. Newton (*Syll. Jour. of Sc.*, 2d ser. vol. xxxix. p. 286) for calculating the height by one observation of altitude and amplitude of an arch. It seems almost certain that the auroral arches are arcs of circles, of which the centre is the magnetic axis of the earth; or, at least, that they are nearly parallel to the earth's surface, and probably also to the narrow belt or ring surrounding the magnetic and astronomical poles, and passing through Faroe, the North Cape, and the north of Nova Zembla, which Loomis and Fritz have found to be the region of most frequent aurora. This being assumed, Prof. Newton finds that,  $d$  being the distance from the observer to the centre of curvature of the nearest part of this belt (which for England is situated about 75° N. lat., 50° W. long.),  $h$  the apparent altitude of the arch,  $2a$  its amplitude on the horizon,  $x$  its height,  $R$  the earth's radius, and  $c$  the distance of the observer from the ends of the arch,—

$$\sin. \phi = \sin. d \cos. \alpha \operatorname{cosec}. (d+h) \quad (1)$$

$$\tan. c = 2 \sin. h \sin. \phi \operatorname{cosec}. 2\phi \quad (2)$$

and  $x = R (\sec. c - 1) \quad (3)$

He gives the heights of twenty-eight auroras calculated by this method, ranging from 33 to 281 miles, with a mean of 130 miles. The method, of course, rests on the assumption that auroral arches are arcs of circles, but it is decidedly confirmatory both of this assumption and of the heights

calculated by other methods. It cannot well be objected that such altitudes are beyond the limits of our atmosphere, since Prof. A. S. Herschel (*Nature*, vol. iv. 504) gives the height of twenty meteors varying from 40 to 118 miles, with an average of about 70 miles, and it is almost certain that these bodies are rendered incandescent by atmospheric friction. Assuming 0° C. as the temperature at the earth's surface, and the absolute zero. - 273° C. as a minimum for the auroral region, the pressure would be about 0.2 millimetre (0.0078 inch) at a height of 100 kilometres (62 miles) above the earth's surface. This result, of course, assumes a good deal; but if correct, it implies a vacuum attainable with difficulty even with the Sprengel pump. The pressure may, however, be much greater in the path of the auroral beams, since, as Prof. A. S. Herschel suggests, electrical repulsion may carry air or other matter up to a great height. A similar effect is observed in the so-called vacuum tubes, in which the pressure becomes much greater in the narrow central part, while the discharge is passing. It is found that the apparent altitude of the auroral corona is always a little less than that indicated by the dipping needle, owing to the curvature of the lines of magnetic force, or, in other words, because its altitude corresponds with the inclination of the parallel of latitude over which it is actually situated; and Galle has suggested (*Pogg. Ann.*, cxlvi. 133), that from this divergence the height may be calculated, and, indeed, gives a series of heights so determined, which do not differ materially from Prof. Newton's. It is, however, doubtful if the position of these coronae, and consequently the value of the small angle (not more than 4° or 5°), admit of sufficiently accurate determination for such a use.

Early observers, and especially Mr Canton, conjectured that the aurora was an electric discharge in the rarefied upper atmosphere, and the resemblance between it and the phenomena exhibited by discharges in an air-pump vacuum confirmed the idea. Recent spectroscopic observations have thrown some little doubt on this conclusion, or at least have shown that there is still a mystery left unexplained. When the light of any glowing gas is analysed by the prism, it is found to consist of a series of coloured lines and bands, of which the number and position is dependent on the nature of the gas, and which is called its spectrum. The light of the aurora gives a spectrum usually consisting of a single line in the greenish yellow, which does not coincide with a principal line of any known substance, — a spectrum totally different from those of the gases of the atmosphere. Besides this line there is occasionally visible a sharp line in the red, and several fainter and more refrangible bands. The following table includes most of the principal determinations of the auroral lines, which have hitherto been published:—

WL.	Observer.	Remarks.	Mean WL.	Prob. Error.
1	6297	Vogel	±14. Bright red line only occasionally visible	6303 ± 8.1
	6279	Zöllner		
	6350	Ellery		
	6290	Oettingen		
	6300	C. Piazzi Smyth		
	5567	Ångström		
2	5569	Vogel	±2	5569 ± 2.9
	5571			
	5570	Winlock		
	5548	Oettingen		
	5545	Struve		
	5569	N. German Polar Expedition		
	5570	Peirce		
	5573	Respighi		
5579	C. Piazzi Smyth			
5600	Ellery			

WL.	Observer.	Remarks	Mean WL.	Prob. Error.
3	5440 Winlock	±5	5342	±16
	5390 Vogel			
	5315 Peirce			
4	5320 Alvan Clark	±29	5214	±5.4
	5238 Vogel			
	5205 Peirce			
	5200 Winlock			
5	5200 C. Piazzi Smyth	±21	5161	±9.7
	5235 Lemström			
	5210 Angström			
	5189 Vogel			
	5120 Oettingen			
6	5165 Backhouse	±3	4984	±11
	5170 Barker			
	5004 Vogel			
	4930 Oettingen			
	5015 Backhouse			
	5020 Barker			
7	4990 Barker	Broad band somewhat fainter in the middle. ±3	4823	±9.3
	4870 Angström			
	4800 C. Piazzi Smyth			
	4850 Clark			
	4820 Barker			
	4694 Vogel			
	4663 Vogel			
8	4629 C. Piazzi Smyth	±25	4667	±9.8
	4705 Barker			
	4720 Angström			
	4694 Lemström			
	4660 Oettingen			
	4625 Backhouse			
	4040 Peirce			
	4310 Peirce			
9	4240 Oettingen	±25	4299	±9.3
	4905 Backhouse			
	4350 Clark			
	4310 Barker			
	4262 Lemström			
	4320 C. Piazzi Smyth			
4110 Lemström				

Vogel remarks that the line at 5569, which is often the only one visible, as well as the faint band at 4667, become noticeably fainter when the red line is visible, while under the same circumstances that near 5189, as well as the red line, is very brilliant. This fact, which has also been noted by other observers, makes it almost certain that the auroral spectrum is not a simple one, but is derived either from two or more sources, or from the same source under very varying conditions. Angström says (*Nature*, x. 211)—

"It may be assumed that the spectrum of the aurora is composed of two different spectra, which, even although appearing sometimes simultaneously, have in all probability different origins. The one spectrum consists of the homogeneous yellow light which is so characteristic of the aurora, and which is found even in its weakest manifestation. The other spectrum consists of extremely feeble bands of light, which only in the stronger aurora attain such intensity as enables one to fix their position even approximately. As to the yellow line in the aurora, or the one-coloured spectrum, we are as little able now as when it was first observed to point out a corresponding line in any known spectrum. True, Piazzi Smyth (*Comptes Rendus*, lxxiv. 597) has asserted that it corresponds to one of the bands in the spectrum of hydrocarbons; but a more exact observation shows that the line falls into a group of shaded bands, which belong to the spectrum, but almost midway between the second and third. Herr Vogel has observed that this line corresponds to a band in the spectrum of rarefied air (*Pogg. Ann.*, cxlvi. 582). This is quite true, but in Angström's opinion is founded on a pure misconception. The spectrum of rarefied air has in the yellow-green part seven bands of nearly equal strength, and that the auroral line corresponds with the margin of one of these bands, which is not even the strongest, cannot be anything else than merely accidental."

Angström's own view is that this line is due to fluorescence or phosphorescence, and he remarks that "since fluorescence is produced by the ultra-violet rays, an electric discharge may easily be imagined, which though in itself

of feeble light, may be rich in ultra-violet rays, and therefore in a condition to cause a sufficiently strong fluorescence. It is also known that oxygen is phosphorescent, as also several of its compounds." We are, however, just as ignorant of any body which would give such a light by phosphorescence or fluorescence as by ignition, and it seems more probable that the light may be due to chemical action. It is assumed by Angström that water vapour is necessarily absent in the higher atmosphere on account of the cold, but when we remember that its molecular weight is lighter than that of oxygen in the proportion of 9 to 16, it is not unlikely that it may attain great elevations under the very low tensions that prevail at such heights, and it is possible also that both it and other bodies may, by electric repulsion in the auroral beams, be carried up much above the level which they would attain by gravity. If, then, electric discharges take place between the small sensible particles of water or ice in the form of mist or cirrus, as Silbermann has shown to be likely, surface decomposition would ensue, and it is highly probable that the nascent gases would combine with emission of light. It has been almost proved in the case of hydrogen phosphide that the very characteristic spectrum produced by its combustion is due neither to the elements nor to the products of combustion, but to some peculiar action at the instant of combination, and it is quite possible that, under such circumstances as above described, water might also give an entirely fresh spectrum.

It is, perhaps, proper to mention that H. R. Procter found an apparent coincidence by often repeated direct comparison with a band frequently seen both in air and oxygen tubes, which he eventually succeeded in tracing with tolerable certainty to some form of hydrocarbon. The comparison spectrosopes were only of low dispersion, but on more accurate measurement of the carbon band it was found that, though more refrangible than the first band of citron acetylene (candle-flame), it was still less so than careful measurement assigns to the aurora. In addition, the band was shaded towards the violet, which is not the case with that of the aurora, though with feeble light it seemed like a line.

If, leaving the citron line, we pass on to the feeble spectrum towards the violet, we shall obtain more hopeful coincidences. Angström thinks that three of the bands correspond with the three brightest bands of the violet aurora of the negative pole in rarefied air, and has tried to reproduce the conditions of the aurora on a small scale. He says—

"Into a flask, the bottom of which is covered with a layer of phosphoric anhydride, the platinum wires are introduced, and the air is pumped out to a tension of only a few millimetres. If the inductive current of a Ruhmkorff coil be then sent through the flask, the whole flask will be filled, as it were, with the violet light, which otherwise proceeds only from the negative pole, and from both electrodes a spectrum is obtained consisting chiefly of shaded violet bands. If this spectrum be compared with that of the aurora, Angström thinks the agreement between the former and some of the best established bands of the latter is satisfactory.

Lines.	Wave Lengths.
Of the aurora spectrum,	according to Barker, 431 470.5 ...
	" Vogel, .. 469.4. 523.3
	" Angström, .. 473 521
	" Lemström, 426.2 469.4 523.5
	Mean, 428.6 470.3 522.6
Of the spectrum of the violet light,	427.2 470.7 522.7

In the neighbourhood of the line 469.4 Herr Vogel has, moreover, observed two weak light-bands, 466.3 and 463.9 (l). The spectrum of the violet has also two corresponding shaded bands, 465.4 and 460.1.

"Should the aurora be flamy, and shoot out like rays, there is good reason for assuming a disruptive discharge of electricity, and then there ought to appear the strongest line in the spectrum of the air, the green, whose wave-length is 500.3. Precisely this has actually been observed by Vogel, and has, moreover, been seen

by Angström and others. Finally, should the aurora be observed as it appears at a less height in the atmosphere, then are recognised both the hydrogen lines and also the strongest of the bands of the dark-banded air-spectrum. There are found also again nearly all the lines and light-bands of the weak aurora spectrum whose position has with any certainty been observed."

With regard to the red line, which is sometimes perfectly sharp and well defined, and occasionally, though very rarely, even as bright as the citron line, scarcely even a plausible theory has been hazarded. That it is not the C line of hydrogen is certain, as they have been directly compared, and are widely separated; and none of the air lines near its position are at all comparable to it in brightness. Vogel thinks it may "correspond with the first system of lines in the spectrum of nitrogen (6620 to 6213), and that probably only the bright part of this group of lines is visible on account of the extreme faintness of the aurora." This, however, cannot be the case, since the present writer has seen it both bright and sharp. Vogel points out that the line near 5189 closely corresponds to an oxygen line of that wave-length which is bright and constant under very different conditions of pressure and temperature. He states that the faint line near 5390 corresponds in like manner to a nitrogen line. He points out that, though the correspondences with the iron lines are very striking, but little weight can be laid on the fact, since many of the brightest lines of the iron spectrum do not appear. The following table gives the principal iron lines (Thalén) and the auroral ones; and it will be seen that the former are so abundant that coincidences could scarcely fail:—

Iron. Brightness.	Aurora.	Iron. Brightness.	Aurora.	Iron. Brightness.	Aurora.
6490	6	5546	10	5167	8
6399	10	5429	10	5189	8
6360	8	5405	8	5051	8
6245	8	5403	8	5049	8
6230	8	5396	8	4977	10
6190	8	5392	8	4939	10
6136	8	5371	10	4918	8
6065	8	5346	8	4890	10
5658	10	5339	8	4871	8
5614	10	5327	10	4870	8
5602	10	5323	8	4415	10
5597	10	5283	8	4404	10
5591	8	5269	10	4383	10
5586	10	5268	10	4325	10
5575	8	5266	8	4307	10
5572	10	5232	10	4271	10
5569	8	5226	10	4251	10
5545	10	5192	8	4250	10

Angström asserted some years since that he had detected the principal line of the aurora in the spectrum of the zodiacal light, but he appears to have been misled by a faint aurora, for more recent observers, and notably Prof. C. Piazzi Smyth, Mr Backhouse, and A. W. Wright (*Sill. Jour. of Sc.*, viii. 39), have found that the spectrum of the zodiacal light is continuous and quite analogous to that of twilight or faint starshine, and polariscope observations prove that it is mostly reflected. The very faint line positioned by Alvan Clark at 5320 has been said by Winlock to coincide with the principal coronal line 5322. The position of the auroral line is uncertain; and even if it were accurate, a single doubtful coincidence with a faint line is not the least proof of identity.

We have already remarked the manifest relation between the forms and position of auroræ and the earth's lines of magnetic force, and in addition to this have noted the disturbance of the magnetic needle during auroral displays. It is not, however, at such times only that the magnetic elements are subject to variation; the total force, declination, and inclination, all are constantly varying both regularly with the hours of the day and the seasons of the year, and irregularly at uncertain times. The irregular

oscillations when violent are called magnetic storms, and it must be noted that auroral display never takes place except during such disturbances, although a large proportion of the most remarkable magnetic storms are unaccompanied by visible aurora.

Franklin, who was one of the first observers of this relation (at Fort Enterprise, 64° 30' N., 113° 10' W.), says of the magnetic needle,—“The motion communicated to it was neither sudden nor vibratory. Sometimes it was simultaneous with the formation of arches, prolongation of beams, or certain other changes of form or action of the aurora. But generally the effect of these phenomena upon the needle was not visible immediately, but in about half an hour or an hour the needle had attained its maximum of deviation. From this its return to its former position was very gradual, seldom regaining it before the following morning, and frequently not until the afternoon, unless it was expedited by another arch of the aurora operating in a direction different from the former one.”

“The arches of the aurora,” he adds, “most commonly traverse the sky nearly at right angles to the magnetic meridian, but deviations from this direction, as has already been stated, were not rare; and I am inclined to consider that these different positions of the aurora have considerable influence on the direction of the needle. When an arch was nearly at right angles to the magnetic meridian, the motion of the needle was towards the west. This westward motion was still greater when one extremity of the arch bore 301°, or about 59° to the west of the magnetic north, that is, when the extremity of the arch approached from the west towards the magnetic north. A westerly motion also took place when the extremity of an arch was in the true north, or about 36° to the west of the magnetic north, but not in so great a degree as when its bearing was about 301°. A contrary effect was produced when the same end of an arch originated to the southward of the magnetic west, viz., when it bore from 245° to 234°, and of course when its opposite extremity approached nearer to the magnetic north. In these cases the motion of the needle was towards the east. In one case only a complete arch was formed in the magnetic meridian, in another the beam shot up from the magnetic north to the zenith; and in both these cases the needle moved towards the west.

“The needle was most disturbed on February 13th, P.M., at a time when the aurora was most distinctly seen passing between a stratum of clouds and the earth, or at least illuminating the face of the clouds opposed to the observer. This and several other appearances induced me to infer that the distance of the aurora from the earth varied on different nights, and produced a proportionate effect on the needle. When the light shone through a dense hazy atmosphere, when there was a halo round the moon, or when a small snow was falling, the disturbance was generally considerable; and on certain hazy, cloudy nights the needle frequently deviated in a considerable degree, although the aurora was not visible at the time. Our observations do not enable us to decide whether this ought to be attributed to an aurora concealed by a cloud or haze, or entirely to the state of the atmosphere. Similar deviations have been observed in the day-time, both in a clear and cloudy state of the sky, but more frequently in the latter case. An aurora sometimes approached the zenith without producing any change in the position of the needle, as was more generally the case; whilst at other times a considerable alteration took place although the beams or arches did not come near the zenith. The aurora was frequently seen without producing any perceptible effect on the needle. At such times its appearance was that of an arch, or an horizontal stream of dense yellowish light, with little or no internal motion. The disturbance in the needle was not always proportionate to the agitation of the aurora, but it was always greater when the quick motion and vivid light were observed to take place in a hazy atmosphere. In a few instances the motion of the needle was observed to commence at the instant a beam darted upwards from the horizon; and its former position was more quickly or slowly regained according to circumstances. If an arch was formed immediately afterwards, having its extremities placed on opposite sides of the magnetic north and south to the former one, the return of the needle was more speedy, and it generally went beyond the point from whence it first started.”

Speaking of the aurora of May 13, 1869, M. Lamont of Munich says (*Comptes Rendus*, lxxviii. 1201)—

“1. During 40 years I have only seen seven or eight auroras at Munich, and this small number is insufficient for a study of the characters of the phenomenon.

“2. Auroras, whether visible at Munich or not, are always accompanied by magnetic perturbations.

"3. In the perturbations of declination which I have observed for 28 years, I have been unable to recognise any general law.

"4. The perturbations of horizontal intensity commence in general by an increase of that force, and finish always by a diminution, which lasts for two or three days.

"5. In all perturbations there is a constant relation between changes of inclination and the simultaneous changes of horizontal intensity, such that an augmentation of intensity of  $\frac{1}{100}$  corresponds to a diminution of inclination of  $8^{\circ} 23'$  (for Munich).

"6. In telegraphic wires we cannot observe the existence of a constant terrestrial current, since the conductivity of the soil is infinitely greater than that of the telegraphic wire, and it is only sudden changes that manifest themselves. In consequence, during magnetic perturbations in the galvanometer of a telegraphic wire, we only see irregular deflections to right or left, succeeding each other at intervals of a few minutes.

"In 1850 and 1851 we made electrical observations from hour to hour, from 7 A.M. to 6 P.M., without being able to see any connection between the atmospheric electricity and the magnetic perturbations. Later I abandoned these observations, because the indications of the electrometers depended too much on local and accidental circumstances."

It should be noted here that the horizontal component of magnetic force varies with the inclination as well as with the intensity of the total force, and the ratio noted above is almost exactly that which would be produced by a change in the inclination alone; and it would appear as if the actual horizontal force, independent of the inclination, was subject to comparatively little variation. This is not improbable, since variations in the horizontal force could correspond only to electro-magnetic easterly or westerly currents, while changes in declination, inclination, and vertical force might correspond to currents from the magnetic north and south, which there is reason to believe are most frequent in auroral displays.

To give some idea of the extent of magnetic perturbations, we may mention that during the aurora of 13th May 1869, the declination at Greenwich varied  $1^{\circ} 25'$ , while the vertical force experienced four successive maxima, and the greatest oscillation amounted to 0.04 of its total mean value. The horizontal force at the same time only varied 0.014 of its mean value. During the aurora of the 15th April of the same year the declination at Stonyhurst varied  $2^{\circ} 23' 14''$  in nine minutes.

The electric currents produced at such times in telegraph wires, though transient, are often very powerful. Loomis (*Sill. Jour.*, vol. xxxii.) mentions cases where wires had been ignited, brilliant flashes produced, and combustible materials kindled by their discharge. It often happens that the ordinary signals are completely interrupted during their continuance.

In addition to the resemblance between the auroral phenomena and those of electric discharges in rarefied gases which we have already mentioned, we have seen that auroral displays are accompanied by marked disturbances both in the direction and force of terrestrial magnetism. This fact is in itself almost proof of their electrical character, and, taken in conjunction with the strong "earth-currents" which are at such times produced in lines of telegraph, and with the manifest polarisation of the arches and rays with regard to the magnetic meridian, may be considered as conclusive that the aurora is some sort of electric discharge. There are still some points with regard to the origin of this electricity which are unexplained, and it is uncertain whether the magnetic disturbance causes the electrical phenomena, or *vice versa*. It has been shown by Prof. Plücker that when an electric discharge takes place through rarefied gas in the field of a magnet, it is concentrated in the magnetic curves, which are the only paths in which it can move without being disturbed by the magnet. This is well shown in De la Rive's well-known experiment, in which an electro-magnet is enclosed in an electric egg. As soon as the magnet is set in action, the discharge, which had before filled the egg, is concentrated into a defined band of light, which rotates steadily round the

magnet,—the direction of its rotation being changed by reversal either of the current or of the polarity of the magnet. If we suppose that the aurora is an electric discharge passing from one magnetic pole to the other, and following the terrestrial magnetic curves, we shall find that the theory agrees with observed facts even in its lesser details. In these latitudes the magnetic curves are sensibly straight and parallel, and are inclined S.E. at an angle of about  $70^{\circ}$  from the perpendicular, and, by the well-known laws of perspective, will appear to converge towards this point, as, in fact, the auroral streamers do. The streamers should move from east to west, or from west to east, according as the discharge is from north to south, or *vice versa*, and, in fact, they are in constant motion. Professor Loomis (*Sill. Jour. of Sc.*, xxxiv. 45) gives a catalogue of forty-six cases of such movement, of which thirty-one were from E. to W. and only fifteen in the opposite direction; and as part of these apparent motions are due to a real motion from N. to S., he concludes that the actual motion of the streamers is from about N.N.E. to S.S.W. This would make the north pole the negative electrode, which is most likely usually the case. Prof. Loomis has shown that during auroral displays electrical currents traverse the earth's surface in the same general direction, though subject to great variation in intensity and even to reversal. Waves of magnetic disturbance are also propagated in the same direction (*ibid.*, xxxii. 318).

With regard to the arches it is evident that they are generally circles concentric to the magnetic pole, and it is very probable that they are analogous to the strata often seen in discharges in rarefied gases. Cassiot, quoted by B. V. Marsh (*Sill. Jour.*, xxxi. 316, and *Roy. Soc. Proc.*, vol. x. Nos. 38 and 39), describes an experiment with his great Grove's battery of 400 cells, in which the exhausted receiver was placed between the poles of the large electro-magnet of the Royal Institution:—"On now exciting the magnet with a battery of ten cells, effluent strata were drawn out from the positive pole, and passed along the under or upper surface of the receiver according to the direction of the current. On making the circuit of the magnet and breaking it immediately, the luminous strata rushed from the positive, and then retreated, cloud following cloud with a deliberate motion, and appearing as if swallowed up by the positive electrode." This, as Mr Marsh remarks, bears a very considerable resemblance to the conduct of the auroral arches, which almost invariably drift slowly southward; and we cannot do better than sum up his theory in his own words:—"The foregoing considerations seem to render it probable that the aurora is essentially an electric discharge between the magnetic poles of the earth leaving the immediate vicinity of the north magnetic pole in the form of clouds of electrified matter, which float southward through the atmosphere at a height of 40 miles or more from the earth, sometimes to a distance of more than  $30^{\circ}$  from the pole; that whilst they are thus moving forward, with a comparatively slow and steady motion, or sometimes even remaining almost stationary for a long time, bright streams of electricity are from time to time suddenly shot out from them in a nearly vertical direction, that is to say, in the magnetic curves corresponding to the points from which they originate; that these curves, ascending to a great height beyond the atmosphere, then bending more and more southward and downward until they finally reach corresponding points in the southern magnetic hemisphere, are the pathways by which the electric currents pass to their destination; and that for several hundred miles from the earth these curves are thus traced through space and illuminated with bright electric light; and further, that the magnetism of the earth also causes these luminous currents and the electrified matter

composing the arch to revolve round the magnetic pole of the earth, giving them the motion from east to west, or from west to east, which the components of the arch are observed to have."

The principal difficulties and deficiencies of this hypothesis, which was first suggested by De la Rive, are that it makes no attempt to account for the origin of such an electrical discharge, and that it is difficult to understand how an electric current can traverse vast spaces of the almost perfect vacuum which must exist at the distance from the earth (many hundreds of miles) which is attained by the magnetic curves, since, in the best vacuums of our Sprengel pumps, discharge will not take place even across the interval of a few centimetres. It is not, however, certain that stellar space is an insulator, and it is possible, moreover, that the auroral currents do not follow the magnetic curves through their whole course, since electric discharge is always in the path of least resistance, and this is modified not only by the magnetic forces, but by atmospheric density, and it is possible that on attaining a certain height the current may proceed horizontally on a stratum of least resistance. It need create no surprise that the discharge is generally invisible in the intermediate zone of low latitudes, since this is well accounted for not only by the large surface over which it is spread at great heights, but because this part of its course is at right angles to the line of sight, while in higher latitudes we look at the streamers almost "end-on," and thus have before our eyes a very great depth of luminous gases. It is common enough, too, in discharges in rarefied gases to see the two poles surrounded by luminous auree, while the intermediate space is almost or quite dark, or consists of luminous disks or strise separated by dark spaces. It seems probable that this "glow" discharge in rarefied gases is really a sort of electrical convection, which is propagated comparatively slowly, and from particle to particle; and that the strise are surfaces at which the difference of potential of the moving molecules is so great as to cause discharge between them, while in the intermediate dark spaces the electric force is carried mechanically and silently by the particles moving in regular currents under the repulsive and attractive forces of electrification. On this hypothesis the auroral discharge becomes comprehensible, since we have only to suppose that the electricity is carried mechanically, as it were, through the vacuum spaces, which, if they contain no matter to conduct electricity, can contain none to impede the motion of the molecules. It is, moreover, by no means certain that the bright rays indicate actual currents. They may simply consist of matter rendered luminous in the arches, and projected by magnetic or electrical repulsion in the curves of magnetic force, since Varley (*Roy. Soc. Proc.*, xix. 236) shows that when a glow discharge in a vacuum tube is brought within the field of a powerful magnet, the magnetic curves are illuminated beyond the electrodes between which the discharge is taking place as well as within the path of the current; and also that this illumination is caused by moving particles of matter, since it deflected a balanced plate of talc on which it was caused to impinge. It has also been shown that in electrical discharges in air at ordinary pressures, while the spark itself was unaffected by the magnet, it was surrounded by a luminous cloud or aura, which was drawn into the magnetic curves, and which might also be separated from the spark by blowing upon it. It is evident, therefore, that any mechanical force may separate the luminous particles from the electric discharge which produces them.

With regard to the geographical distribution of aurora, Prof. Loomis (*Sill. Jour.*, xxxi.) has laid down a series of zones of equal auroral frequency, and in Petermann's *Mittheilungen* for October 1874, Prof. Fritz has given a

chart embodying the results of his extensive researches on the same subject. He finds, like Prof. Loomis, that the frequency of auroral display does not continue to increase to the pole, but reaches a maximum in a zone which, for the northern hemisphere, passes through the Faroe Islands, reaches its most southern point, about 57°, nearly south of Greenland, passes over Nain on the Labrador coast, then tends northwards, across Hudson's Bay (60° N. lat.), and through great Bear Lake, and leaves the American continent slightly south of Point Barrow. It then skirts the northern coast of Asia, reaching its most northerly point, about 76° N., near Cape Taimyr, passing through the north of Nova Zembla, and skirting the N.W. coast of Norway. Not only are auroral displays less frequent in Iceland and Greenland than further south, but it is found that while south of this zone auroræ appear usually to the north of the observer, north of it they are generally to the south, and within it, north or south indifferently. South of this lie other zones approximately parallel to it, and of constantly diminishing frequency. That in which the average yearly number of auroræ is 100 passes through the Drontheim, the Orkneys, and the Hebrides, and reaches the American coast just north of Newfoundland. South of this the frequency diminishes rather rapidly. At Edinburgh the annual average is 30, at York 10, in Normandy 5; while at Gibraltar the average is about 1 in ten years.

These curves, which Prof. Fritz calls *isochasmen*, are nearly normal to the magnetic meridians, and bear a close relation to the curves of equal magnetic inclination, especially with those laid down by Hansteen in 1730, while they noticeably diverge in some places from those of Sabine of 1840. They also approximate to the isobaric curves of Schouw, and Prof. Fritz remarks that the curves of greater frequency tend towards the region of lowest atmospheric pressure. It is not unlikely that there may be such a connection, since Prof. Airy has showed a relation between barometric and magnetic disturbances.

It will be noticed that, eastward from England, the isochasmic curves tend rapidly northward, Archangel being only on the same auroral parallel as Newcastle. Prof. Fritz points out that they bear some relation to the limit of perpetual ice, tending most southward where, as in North America, the ice limit comes furthest south. He also endeavours to establish some connection between the periods of maximum of auroræ and those of the formation of ice, and considers ice as one of the most important local causes which influence their distribution. He quotes a curious fact mentioned by several Arctic voyagers, that aurora was most frequently seen when open water was in sight, and usually rather in the direction of the water than of the magnetic north. In this connection it may be well to remind our readers that the water of the Arctic regions is always warmer than the ice fields, and must cause upward currents of damp air. For the southern hemisphere there are not yet sufficient observations to make any determination of geographical distribution.

With regard to distribution in time Loomis and Fritz and Wolf have shown that there are periodical maxima about every ten or eleven years, and that these maxima coincide both with those of sun spots, and of magnetic disturbance. The following are Fritz and Wolf's dates of maxima:—

Sun Spots.	Aurora.	Sun Spots.	Aurora.
1706	1707	1788	1788
1718	1721	1804	1804
1728	1728	1817	1816
1739	1738	1820	1820
1750	1749	1837	1839
1761	1760	1848	1848
1770	1769	1860	1860
1779	1779	1871	1872

The annexed chart from Prof. Loomis's paper (*Sill. Jour.*, April 1873) shows, in a very striking manner, the correspondence of auroræ, magnetic variation, and sun-spot area since 1776. It is not improbable that there may also be changes of longer period which our observations are yet insufficient to determine.

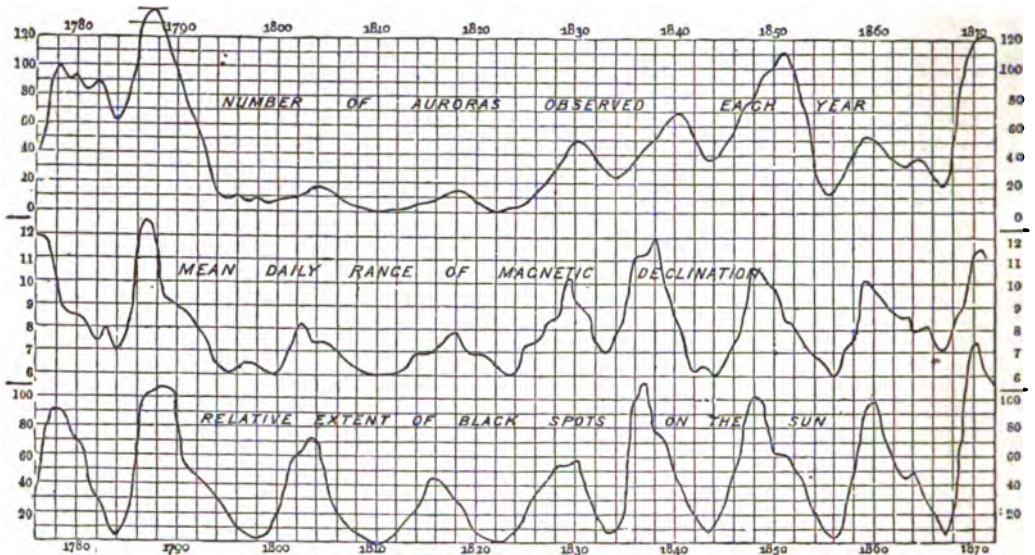

Diagram showing Correspondence of Auroræ, Magnetic Variation, and Sun Spots.

It has frequently been stated that the aurora returned periodically on certain days in the same manner as meteors. On the 3d of February brilliant auroræ occurred in 1750 and 1869, and on the 4th in 1869, 1870, 1871, 1872, 1873, and 1874; on the 13th February in 1575, 1821, 1822, 1865, and 1867; on the 6th March in 1716, 1777, 1843, 1867, and 1868; on the 9th September in 1776, 1827, 1835, 1866, 1868, 1872, and on the 29th in 1828, 1840, 1851, 1852, 1870, and 1872. This conclusion, however, is not supported by systematic investigation. A considerable catalogue of auroræ was divided into decennial periods, and it was found that the maxima of one period rarely coincided with those of others, and that the larger the number of years taken into account the less prominent the maxima appeared,—evident proof that they were only accidental. It may be, however, that if only prominent auroræ had been considered, more periodicity might have been found, or that the periodicity is constant for very short periods only.

Although no daily periodicity can be affirmed, there are two well-marked annual maxima in March and October, of which the latter is the greater, and two minima—the greater in June and the less in January. In this respect the aurora differs from the sporadic meteors, which have a maximum in autumn and a minimum in spring. It also differs from meteors in the hours of its appearance, the former being most frequent before and the latter after midnight.

Although the electric hypothesis is the one generally accepted by scientific men, it is only fair to allude to one that has been recently proposed independently by Dr Zehfuss (*Physikalische Theorie*, Adelman, Frankfurt) and by H. J. H. Groneman of Gröningen (*Astronomische Nachrichten*, No. 2010-2012). According to this view, the light of the aurora is caused by clouds of ferruginous meteoric dust, which is ignited by friction with the atmosphere. Groneman has shown that these might be arranged along the magnetic curves by action of the earth's magnetic force during their descent, and that their in-

fluence might produce the observed magnetic disturbances. The arches may be accounted for by the effects of perspective on columns suddenly terminated at a uniform height by increase of atmospheric density, while the correspondences with iron lines in its spectrum are sufficiently close to favour the idea. Ferruginous particles have been found in the dust of the Polar regions (E. A. Nordenkiöld, *Ast. Nach.*, 1874, § 154), but whether they are derived from stellar space or from volcanic eruption is uncertain. The yearly and eleven-yearly periodicity of auroræ tends to support the theory, but it is a formidable difficulty that, while shooting stars are more frequent in the morning, or on the face of the earth, which is directed forwards in its orbit, the reverse is the case with auroræ. Groneman meets this difficulty by supposing that in the first case the velocity may be too great to allow of arrangement by the earth's magnetic force, and that, consequently, only diffused light can be produced. He accounts for its unfrequency in equatorial regions by the weakness of the earth's magnetic force, and the fact that, when it does occur, the columns must be parallel to the earth's surface. Without pronouncing in favour of this hypothesis, it must be admitted that it furnishes a plausible explanation of the phenomenon, although we have no evidence that meteoric dust, even if it exists, would produce the observed spectrum, and, as has been already remarked, the iron coincidences are of little weight.

Although we must confess that the causes of the aurora are very imperfectly explained, we may hope that the rapid progress which the last few years have witnessed in bringing terrestrial magnetism under the domain of cosmical laws may soon be extended to the aurora, and that we shall see in its fresh evidence that the same forces which cause hurricanes in the solar atmosphere thrill sympathetically to the furthest planets of our system in waves, not only of light and heat, but of magnetism and electricity.

The following is a list of the most important papers, treatises, and works on this subject:—*Berlin Mem.* 1710, l. 181; Halley, *Phil. Trans.* 1716, 1719, xxix. 406 xxx. 584; Hearn, *Phil. Trans.*, xxx

1107; Langworth, Huxham, Hallet, and Callendrina, *Phil. Trans.* xxxiv. 132, 150; Mairan, *Traité de l'Aurore Boréale*, 1733, 1764; Weidler, *De Auroras Boréalibus*; Wargentin, *Phil. Trans.* 1751, p. 126, 1752, p. 169, 1753, p. 35; Bergmann, *Solm. Abh.*, 200, 251; Wiedeburg, *Ueber die Nordlichter*, 8vo, Jena, 1771; Hüpsch, *Untersuchung des Nordlichts*, 8vo, Calcege, 1778; Van Swinden, *Recueil de Mémoires*, Hague, 1784; Cavallo, *Phil. Trans.* 1781, p. 329; Wilke, "Von den Neuesten Erklärungen des Nordlichts," *Schwedisches Mus.*, 8vo, Wismar, 1783; Hey, Wollaston, Hutchinson, Frankha, Figgitt, and Cavendish, *Phil. Trans.* 1790, pp. 32, 47, 101; Dalton's *Meteorological Observations*, 1793, pp. 54, 153; Chiminello, "On a Luminous Arch," *Soc. Ital.*, vii. 163; Loomis, "Electrical and Magnetic Relations," *Sill. Jour.* 2d ser., xxxii. 324, xxxiv. 34, Sept. 1840; on "Catalogue, Geog. dist., Sun spots," &c., *ibid.*, 3d ser. v. 245, &c.; B. V. Marsh, "Electrical Theory," *ibid.* 3d ser., xxxi. 311; Ottingen and Vogel on "Spectrum," *Pogg. Ann.*, cxlvi.

284, 269; Galle and Mirz on "Crown," *ibid.*, cxlvi. 133, cxlii. 112; Silbermann, *Comptes Rendus*, lxxvii. 1049, 1120, 1140, 1164; Prof. Fritz, "Geog. Distrib.," *Petersmann's Mit.*, Oct. 1874; Zehfuss, *Physikalische Theorie*, Adelman, Frankfurt; Ralfour Stewart, *Phil. Mag.* 4th ser., xxxix. 59; A. S. Davis, *ibid.*, xl. 33; C. Piazzi Smyth, *Ed. Ast. Observations*, xlii. R. 85, *Phil. Mag.*, 4th ser., xlix., Jan. 1878; A. S. Herschel, *Nat.*, iii. 9; Sir W. R. Grove and J. R. Capron, *ibid.*, 29; Webb, Glaisher, &c., "Daylight Auroras," *ibid.*, 104, 126, 248, 510, iv. 208, &c.; Heis, "Auroras at Melbourne," *ibid.*, iv. 213; Prof. C. A. Young, *ibid.*, iv. 246; Kirkwood, "Periodicity," *ibid.*, iv. 505; H. E. Procter, *ibid.*, iii. 7, 246, &c.; F. E. Chase, "On Auroras and Gravitating Currents," *ibid.*, iv. 497; H. A. Newton, "Height," *Sill. Jour.* 2d ser., xxxix. 286, 371; Angström, *Pogg. Ann.* ("Jubelband") and *Nat.*, x. 211; J. R. Capron, "Spectrum," *Phil. Mag.*, 4th ser., xlix., April 1875. (H. R. P.)

**AURUNGÁBÁD**, or **AURANGÁBÁD**, a city of India, in the native state of Haidarábád, or the Nizám's dominions, situated in 19° 51' N. lat., and 75° 21' E. long., 138 miles from Púna, 207 from Bombay *via* Púna, and 270 from Haidarábád. It was founded about the year 1620, under the name of Gurka, by Malik Ambar, an Abyssinian, who had risen from the condition of a slave to great influence. Subsequently it became the capital of the Moghul conquests in the south of India. Aurungzebe made it the seat of his government during his viceroyalty of the Deccan, and gave it the name of Aurungábád. It thus grew into the principal city of an extensive province of the same name, stretching westward to the sea, and comprehending nearly the whole of the territory now comprised within the northern division of the presidency of Bombay. Aurungábád long continued to be the capital of the succession of potentates bearing the modern title of Nizám, after those chiefs became independent of Dohli. They abandoned it subsequently, and transferred their capital to Haidarábád, when the town at once began to decline. It is now greatly fallen from its ancient grandeur. The city is but half-peopled, and is half in ruins, presenting everywhere the melancholy appearances of desertion and decay. The population is, however, still considerable, and in the bázár, which is very extensive, various rich commodities, particularly silks and shawls, are exposed for sale. The walls of the town are similar in their construction to those of all the other cities in this quarter of India, being rather low, with round towers.

**AURUNGZEBE**, one of the greatest of the Moghul emperors of Hindustan, was the third son of Shah Jehan, and was born in October 1618. His original name, Mahomet, was changed by his father, with whom he was a favourite, into Aurungzebe, meaning ornament of the throne, and at a later time he assumed the additional titles of Mohi-eddin, reviver of religion, and Alam-gir, conqueror of the world. At a very early age, and throughout his whole life, he manifested profound religious feeling, perhaps instilled into him in the course of his education under some of the strictest Mahometan doctors. He was employed, while very young, in some of his father's expeditions into the country beyond the Indus, gave promise of considerable military talents, and was appointed to the command of an army directed against the Usbeks. In this campaign he was not completely successful, and soon after was transferred to the army engaged in the Deccan. Here he gained several victories, and in conjunction with the famous general, Meer Jumla, who had deserted from the king of Golconda, he seized and plundered the town of Haidarábád, which belonged to that monarch. His father's express orders prevented Aurungzebe from following up this success, and, not long after, the sudden and alarming illness of Shah Jehan turned his thoughts in another direction. Of Shah Jehan's four sons, the eldest,

Dara, a brave and honourable prince, but disliked by the Mussulmans on account of his liberality of thought, had a natural right to the throne. Accordingly, on the illness of his father, he at once seized the reins of government and established himself at Delhi. The second son, Soojah, governor of Bengal, a dissolute and sensual prince, was dissatisfied, and raised an army to dispute the throne with Dara. The keen eye of Aurungzebe saw in this conjuncture of events a favourable opportunity for realising his own ambitious schemes. His religious exercises and temperate habits gave him, in popular estimation, a great superiority over his brothers, but he was too politic to put forward his claims openly. He made overtures to his younger brother Murad, governor of Guzerat, representing that neither of their elder brothers was worthy of the kingdom, that he himself had no temporal ambition, and desired only to place a fit monarch on the throne, and then to devote himself to religious exercises and make the pilgrimage to Mecca. He therefore proposed to unite his forces to those of Murad, who would thus have no difficulty in making himself master of the empire while the two elder brothers were divided by their own strife. Murad was completely deceived by these crafty representations, and at once accepted the offer. Their united armies then moved northward. Meanwhile Shah Jehan had recovered, and though Dara resigned the crown he had seized, the other brothers professed not to believe in their father's recovery, and still pressed on. Soojah was defeated by Dara's son, but the imperial forces under Jesswunt Singh were completely routed by the united armies of Aurungzebe and Murad. Dara in person took the field against his brothers, but was defeated and compelled to fly. Aurungzebe then, by a clever stroke of policy, seized the person of his father, and threw him into confinement, in which he was kept for the remaining eight years of his life. Murad was soon removed by assassination, and the way being thus cleared, Aurungzebe, with affected reluctance, ascended the throne in August 1658. He quickly freed himself from all other competitors for the imperial power. Dara, who again invaded Guzerat, was defeated and closely pursued, and was given up by the native chief with whom he had taken refuge. He was brought to Delhi, exhibited to the people, and assassinated. Soojah, who had been a second time defeated near Allahabad, was attacked by the imperial forces under Meer Jumla and Mahomet, Aurungzebe's eldest son, who, however, deserted and joined his uncle. Soojah was defeated and fled to Aracan, where he perished; Mahomet was captured, thrown into the fortress of Gwalior, and died after seven years' confinement. No similar contest disturbed Aurungzebe's long reign of forty-six years, which has been celebrated, though with doubtful justice, as the most brilliant period in the history of Hindustan. The empire certainly was wealthy and of enormous extent, for there were successively added to it the rich kingdoms of

Bajspore and Golconda, and the barren province of Assam, but it was internally decaying, and ready to crumble away before the first vigorous assault. Two causes principally had tended to weaken the Moghul power. The one was the intense bigotry and intolerant policy of Aurungzebe, which had alienated the Hindus and roused the fierce animosity of the haughty Rajputs. The other was the rise and rapid growth of the Mahratta power. Under their able leader, Sevaji, these daring freebooters plundered in every direction, nor could all Aurungzebe's efforts avail to subdue them. At the close of the long contests between them, the Moghul power was weaker, the Mahratta stronger than at first. Still the personal ability and influence of the emperor were sufficient to keep his realms intact during his own life. His last years were embittered by remorse, by gloomy forebodings, and by constant suspicion, for he had always been in the habit of employing a system of espionage, and only then experienced its evil effects. He died, on the 21st February 1707, at Ahmadnagar, while engaged on an extensive but unfortunate expedition against the Mahrattas.

AUSCHWITZ, or OSWIECIM, a town in Galicia, Austria, on the right bank of the Sola, a tributary of the Wechsel, 33 miles W.S.W. of Cracow. It has a population of upwards of 3800, and carries on a trade in salt. Previous to the first partition of Poland in 1773, it was the seat of a dukedom, which had been united by Sigismund Augustus with the duchy of Zator in 1564.

AUSCULTATION (*auscultare*, to listen), a term in medicine, applied to the method employed by physicians for determining, by the sense of hearing, the condition of certain internal organs. The ancient physicians appear to have practised a kind of auscultation, by which they were able to detect the presence of air or fluids in the cavities of the chest and abdomen. Still no general application of this method of investigation was resorted to, or was indeed possible, till the advance of the study of anatomy led to correct ideas regarding the locality, structure, and uses of the various organs of the body, and to the alterations produced in them by disease. In 1761 Auenbrugger of Vienna introduced the art of percussion in reference more especially to diseases of the chest. This consisted in tapping with the fingers the surface of the body, so as to elicit sounds by which the comparative resonances of the subjacent parts or organs might be estimated. Auenbrugger's method attracted but little attention, till Corvisart, in 1808, demonstrated its great practical importance; and then its employment in the diagnosis of affections of the chest soon became general. Percussion was originally practised in the manner above mentioned (*immediate percussion*), but subsequently the method of *mediate percussion* was introduced by Piorry, and is that now largely adopted. It is accomplished by placing upon the spot to be examined some solid substance named a *pleximeter* (stroke-measurer), upon which the percussion strokes are made either with the fingers or with a small hammer tipped with india-rubber. The pleximeter consists of a thin oval piece of ivory; but one or more fingers of the left hand applied flat upon the part answer equally well, and this is the method which most physicians adopt. Percussion must be regarded as a necessary part of auscultation, particularly in relation to the examination of the chest; for the physician who has made himself acquainted with the normal condition of that part of the body in reference to percussion is thus able to recognise by the ear alterations of resonance produced by disease. But percussion alone, however important in diagnosis, could manifestly convey only limited and imperfect information, for it could never indicate the nature or extent of functional disturbance, or distinguish between different forms of disease, even in

those organs which it had proved to be in an abnormal condition, while in other cases, and notably in many affections of the heart, it could afford no assistance whatever.

In 1819 the distinguished French physician, Laennec, introduced the method of auscultation by means of the stethoscope (*στήθος*, the chest, and *σκοπέω*, to examine), with which his name stands permanently associated. For some time previously, physicians, more especially in the hospitals of Paris, had been in the habit of applying the ear over the region of the heart for the purpose of listening to the sounds of that organ, and it was in the employment of this method that Laennec conceived the idea that these sounds might be better conveyed through the medium of some solid body interposed between his ear and the patient's chest. He accordingly, by way of experiment, rolled up a quire of paper into the form of a cylinder and applied it in the manner just mentioned, when he found, as he states, that he was able to perceive the action of the heart more distinctly than he had ever been able to do by the immediate application of his ear. He thence inferred that not merely the heart's sounds, but also those of other organs of the chest might be brought within reach of the ear by some such instrument, and he, therefore, had constructed the wooden cylinder, or stethoscope, which bears his name. This consisted of a cylindrical piece of wood, about 12 inches long, with a narrow perforation from end to end, the extremity for applying to the chest having a movable piece of conical form fitting into the cylinder, which was withdrawn by the physician while listening to the sounds of respiration, the complete instrument being used for examining the sounds of the voice and those of the heart. This instrument, though rendered portable by being made to screw into two halves, was inconveniently large and heavy, and was subsequently modified by Piorry to the form now generally used of a thin narrow cylinder of about 7 inches long, with an expansion at one end for applying to the chest, and a more or less flattened surface at the other for the ear of the listener. Having ascertained by careful observation the sounds elicited on auscultation of the healthy chest, Laennec studied the modifications of these as produced by disease; and by comparing cases with one another, and especially by investigating the state of the affected parts after death, he was able, in his celebrated *Traité de l'Auscultation médiate*, to lay the foundation for a rational system of diagnosis of the great classes of pulmonary and heart complaints. It does not, however, appear to be the case, as Laennec supposed, that *mediate auscultation* by the stethoscope is superior in an acoustic point of view to *immediate auscultation* by the unaided ear. On the contrary, sounds are heard louder by the latter than by the former method. Nevertheless, the stethoscope possesses special advantages, among the chief of which are that by its use particular areas can be examined and compared with greater accuracy; that it can be applied to all parts of the chest, and that it can be used in all cases where, from the sex or the bodily condition of the patient, the direct application of the ear is inadmissible. On the other hand, immediate auscultation is to be preferred in the examination of young children, who are readily frightened by the sight, and still more by the pressure upon them, of the stethoscope.

The whole subject of auscultation has been greatly elaborated since the time of Laennec, and while some of his opinions have been found to require modification, continued investigation only serves more clearly to demonstrate the value of this method of diagnosis, and to elicit fresh and more accurate results from its employment. Although much remains to be done in the way of the correct interpretation of the phenomena observed in auscultation, yet the facts already established are among the most important



acquisitions in the whole domain of practical medicine. The numerous diseases affecting the lungs can now be recognised and discriminated from each other with a precision which, but for auscultation and the stethoscope, would have been altogether unattainable, a point which bears most intimately upon the treatment of this great and common class of ailments. The same holds good in the case of the heart, whose varied and often complex forms of disease can, by auscultation, be identified with striking accuracy. But in addition to these its main uses, auscultation is found to render great assistance in the investigation of many obscure internal affections, such as aneurisms and certain diseases of the œsophagus and stomach. To the accoucheur the stethoscope yields valuable aid in the detection of some forms of uterine tumours, and especially in the diagnosis of pregnancy,—the auscultatory evidence afforded at a particular stage by the sounds of the fetal heart being by far the most reliable of the many signs of that condition. (J. O. A.)

AUSONIUS, DECIMUS MAGNUS, a Roman poet of the 4th century, was the son of an eminent physician, and born at Burdigala (*Bordeaux*) about 310 A.D. His education was conducted with unusual care, either because his genius was very promising, or because the scheme of his nativity, which had been cast by his maternal grandfather, was found to promise great fame and advancement. He made extraordinary progress in classical learning; and, after completing his studies at Toulouse, he practised for a time at the bar in his native place. At the age of thirty he became a teacher of grammar, and soon afterwards was promoted to the professorship of rhetoric. In this office he acquired so great a reputation that he was appointed preceptor to Gratian, the Emperor Valentinian's son. The rewards and honours conferred on him for the faithful discharge of his duties, prove the truth of Juvenal's maxim—that when Fortune pleases she can raise a man from the humble rank of rhetorician to the dignity of consul. He was appointed consul by the Emperor Gratian in the year 379, after having filled other important offices; for besides the dignity of quaestor, to which he had been nominated by Valentinian, he was made præfect of Latium, of Libya, and of Gaul, after that prince's death. His speech, returning thanks to Gratian on his promotion to the consulship, is a good specimen of high-flown rhetorical flattery. The time of his death is uncertain, but he was alive in 388, and probably survived till about 394. From references in his works he appears to have been a convert to Christianity.

Of his prose writings, there are extant the *Actio ad Gratianum*, the *Periochæ* (or summaries) in *Iliadem et Odysseam*, and one or two of the *Epistolæ*. The principal pieces in verse are the *Epigrammata*, some of which are extremely felicitous; the *Parentalia* and *Commemoratio Professorum Burdigalensium*, which give interesting details concerning his relations and literary friends; the *Epistolæ*; and, finally, the *Idyllia*, a collection of twenty small poems, the most famous of which are the *Cento Nuptialis*, an obscene selection of lines from Virgil, and the *Mœtilla*, a descriptive poem on the river Mœselle, containing some good passages. Ausonius was rather a man of letters than a poet; his wide reading supplied him with materials for verse, but his works exhibit no traces of a true poetic spirit; even his versification, though ingenious, is frequently defective. The best editions of his works are those of Tollius (Amsterdam, 1669), and Bouchay (Paris, 1780), and the *Bipontine* (1785). The *Mœtilla* has been edited separately by Bœcking (1828, 1842).

AUSPICIA. See AUGURS.

AUSSIG, AUBSKYENAD, or LABEM, a town of Austria, in Bohemia, situated in a mountainous district, at the confluence of the Bils and the Elbe. It carries on a large manufacture of woollen wares, linen, paper, &c. Its chemical works alone give employment to 500 operatives, and about 600 boats are annually built in its yards. Besides a considerable trade in grain, fruit, mineral-waters, and

wood, there is a large export of coal from the neighbouring mines. Aussig, once strongly fortified, was destroyed by the Hussites in 1426, burned down in 1683, and captured by the Swedes in 1639. Population, 10,933.

AUSTEN, JANE, one of the most distinguished modern British novelists, was born December 16, 1775, at the parsonage of Steventon, in Hampshire, of which place her father was for many years rector. Her life was singularly tranquil and void of incident, so that but few facts are known concerning her from which an idea of her character can be formed. She was tall and attractive in person, and of an extremely kind and gentle disposition. Under her father's care she received a sound education, though she had few of the modern accomplishments. She had a fair acquaintance with English literature, her favourite authors being Richardson, Johnson, Cowper, and Crabbe; she knew French well and Italian slightly, had some taste for music, and was noted for her skill in needlework. She was a particular favourite with all her younger relatives, especially on account of her wonderful power of extemporising long and circumstantial narratives. At a very early age she seems to have begun to exercise her faculty for composition, and wrote several short tales and fragments of larger works, some of which have been found among her papers. These first essays are written in a remarkably pure and vigorous style, and are not unworthy of her later reputation. In 1796 her first large work, *Pride and Prejudice*, was begun and completed in about ten months; *Sense and Sensibility* and *Northanger Abbey* were written soon after, during 1797 and 1798. Many years elapsed before these works were published, for the first attempts to introduce them to the public were badly received. *Pride and Prejudice* was summarily rejected by Mr Cadell; *Northanger Abbey* was sold for £10 to a Bath publisher, but was never printed, and, many years after, was bought back by the author. From 1801 to 1805 the Austen family resided in Bath, they then removed to Southampton, and finally, in 1809, settled at Chawton. There Miss Austen, who for some years had written nothing, resumed her pen, and began to prepare for publication her early novels. *Sense and Sensibility* was published in 1811, *Pride and Prejudice* in 1813, *Mansfield Park* in 1814, *Emma* in 1816. These four were anonymous. *Northanger Abbey* and *Persuasion* appeared together under Miss Austen's name in 1818, after her death. Early in 1816 her health had begun to give way; her strength gradually declined, and on the 18th July 1817, she died at Winchester, whither she had removed for change of air and scenery. She was buried in the cathedral of that town.

Miss Austen's works at the time of their appearance were on the whole well received, and brought her considerable reputation,—more, indeed, than she had herself anticipated; but their full merits were not then so generally recognised as they have since been. The novels most popular at that time belonged to the class of which Mrs Radcliffe's *Udolpho*, Godwin's *St Leon* or *Caleb Williams*, and Lewis's *Monk* are the best known representatives. Against this style of fiction Miss Austen from the first set her face; she had a remarkably keen sense of humour, and the ludicrous aspect of these thrilling incidents, mysterious situations, and unnatural characters, presented itself very strongly to her mind. *Northanger Abbey*, one of her earliest productions, is a clever and well-sustained parody on romances of this type. She did not, however, confine herself to mere negative criticism, but resolved to show that the interest of readers could be roused and sustained by a story absolutely free from the whole machinery of romance and exaggerated sentiment, but presenting an accurately-drawn picture of quiet, natural life. This task she accomplished with complete success; she was the first

to introduce the novel of domestic life, and her writings are still the best specimens of that class of fiction. It could hardly be expected that such works would become immediately popular; the characters, the motives of action, and the plot itself were too ordinary, one may say too commonplace, to appeal strongly to the sympathies of the general mass of readers. Her colours were not showy enough to strike the vulgar eye. It is probable, indeed, that her admirers will always be few in number; for not only does it require a somewhat cultivated taste to appreciate the rare skill with which the scanty materials of her tales are handled, but the author's experience of life was so limited that her works are entirely wanting in certain elements—such as depth of feeling and breadth of sympathy—which are indispensable before a work of fiction can exercise any considerable influence on the public mind.

The framework in nearly all Miss Austen's novels is the same, taken as they are from ordinary English middle-class life; her characters are in no way distinguished by any remarkable qualities, they are such persons as one would readily expect to meet in every-day life; the plot is exceedingly simple, and the incidents, never rising above the level of the most common-place occurrences, flow naturally from the characters of the actors. In the hands of most writers such materials would infallibly become monotonous and tiresome; but from any danger of this Miss Austen is completely freed by her wonderful power of exciting interest in the "involvements and feelings of ordinary life," and the skill with which, by a series of imperceptible but effective touches, she discriminates her characters, rounds them off, and makes them stand out from the canvas real and living personages. Her gallery of portraits is certainly small, and the same character appears over and over again, but each figure is so distinctly drawn, and has such marked individuality, that one is never struck with a sense of repetition. A warm admirer of her works, Archbishop Whately, has compared them to the carefully-executed pictures of the Dutch school; perhaps the analogy of miniature painting, suggested by the author herself, is more happy and expressive.

Miss Austen's life has been written by her nephew, Rev. J. Austan-Leigh (1870, 2d ed., 1871), who has also published some extracts from her papers, including a short tale, *Lady Susan*, written in the form of letters; a fragment of a larger work called *The Watsons*; the first draft of a chapter in *Persuasion*; and the beginning of a novel, on which she was engaged at the time of her death.

AUSTERLITZ, a small town of Moravia, 13 miles E.S.E. of Brünn, containing a magnificent palace belonging to the prince of Kaunitz-Rietberg, and a beautiful church. It has been rendered memorable by the great victory obtained in its vicinity, on the 2d December 1805, by the French under Napoleon, over the united forces of Austria and Russia under their emperors. Population, 3450.

AUSTIN, JOHN, one of the ablest English writers on jurisprudence, was born on the 3d March 1790. At an early age he entered the army, and passed five years in military service. He then retired, applied himself to the study of law, and was called to the bar in 1814. His powers, though admirably adapted for grasping the fundamental principles of law, were not of a nature to render him successful in legal practice. His health, too, was delicate, and in 1825 he resigned active employment at the bar. In the following year, however, he was appointed to the chair of jurisprudence in the newly-founded London university. He immediately crossed over to Germany to prepare himself for his new duties, and at Bonn became acquainted with some of the most eminent German jurists. His lectures were at first attended by a number and a class of students quite beyond his anticipations. Among his

hearers were such men as Lord Romilly, Sir G. C. Lewis, and J. S. Mill. From Mill's notes some of the lectures were afterwards published, and he has given an admirable account of Austin in his *Dissertations* (vol. iii.) But it soon became apparent that there would be no steady demand for training in the science of law, which, though useful, was not of immediate utility in practice. Under these circumstances Austin, who was almost too conscientious in regard to his own work, thought it right to resign the chair in 1832. An attempt to institute lectures at the Inner Temple also failed, and, as his health was delicate, he retired to Boulogne, where he remained for nearly two years. In 1837 he acted as royal commissioner in Malta, and discharged the duties of that office most efficiently. The next ten years were spent in travelling on the Continent, as the state of his health hardly permitted him to reside in England. The Revolution of 1848 drove him from Paris, and on his return to England he settled at Weybridge, in Surrey, where he remained till his death in December 1859. Austin wrote one or two pamphlets, but the chief work he published was his *Provinces of Jurisprudence Determined* (1832), a treatise on the relation between ethics and law, which gives a clear analysis of the notion of obligation, and an admirable statement of utilitarianism, the ethical theory adopted by the author. After his death, his widow, Mrs Sarah Austin, published his *Lectures on Jurisprudence; or, The Philosophy of Positive Law*. These, combined with the *Provinces*, have been edited, under the same title, by Mr R. Campbell, and reached in 1875 a fifth edition.

AUSTIN, SARAH TAYLOR, translator and miscellaneous writer, was born in 1793. She was one of the Taylor family of Norwich, several of whose members had distinguished themselves in the fields of literature and science. She was the youngest child of her family, received a liberal and solid education at home, chiefly from her mother, and had the advantage, too, of enjoying in her father's house much intellectual society. She grew up a beautiful and cultivated woman, and in 1820 became the wife of John Austin, noticed above. They settled in London, and among the familiar visitors of their house were Bentham, the Mills (father and son), the Grotes, Romilly, Buller, Sydney Smith, and other eminent men. She accompanied her husband in 1827 to Bonn, where they spent some months, and made acquaintance with Niebuhr, Schlegel, Arndt, and other distinguished Germans. She afterwards lived some years in Germany and France, and was left a widow in December 1859. Mrs Austin is best known as a singularly skilful translator of German and French works. In 1832 appeared her version of the *Travels of Prince Puckler Muskau*. This was followed by *Characteristics of Goethe* from the German of Falk, *History of the Reformation in Germany and History of the Popes* from the German of Ranke, and *Dr Carove's Story without an End*. She contributed "Travelling Letters" and critical and obituary notices to the *Athenæum*, edited the *Memoir of Sydney Smith* and her daughter Lady Duff Gordon's *Letters from Egypt*, and for some years of her widowhood was occupied in arranging for publication her husband's *Lectures on Jurisprudence*. She was also author of *Germany from 1760 to 1814*, *National Education*, and *Letters on Girls' Schools*. Mrs Austin died at Weybridge in Surrey, 8th August 1867.

AUSTRALASIA, one of the six great geographical divisions of the globe, is situated, as its name indicates, south of Asia, between the equator and 50° S. lat., and 110° and 180° E. long. It comprises the island-continents of New Guinea, Australia, Tasmania, and New Zealand, and the conterminous archipelagoes of New Britannia, Solomon Islands, New Hebrides, Loyalty Islands, and New Caledonia which will be treated of under special headings.





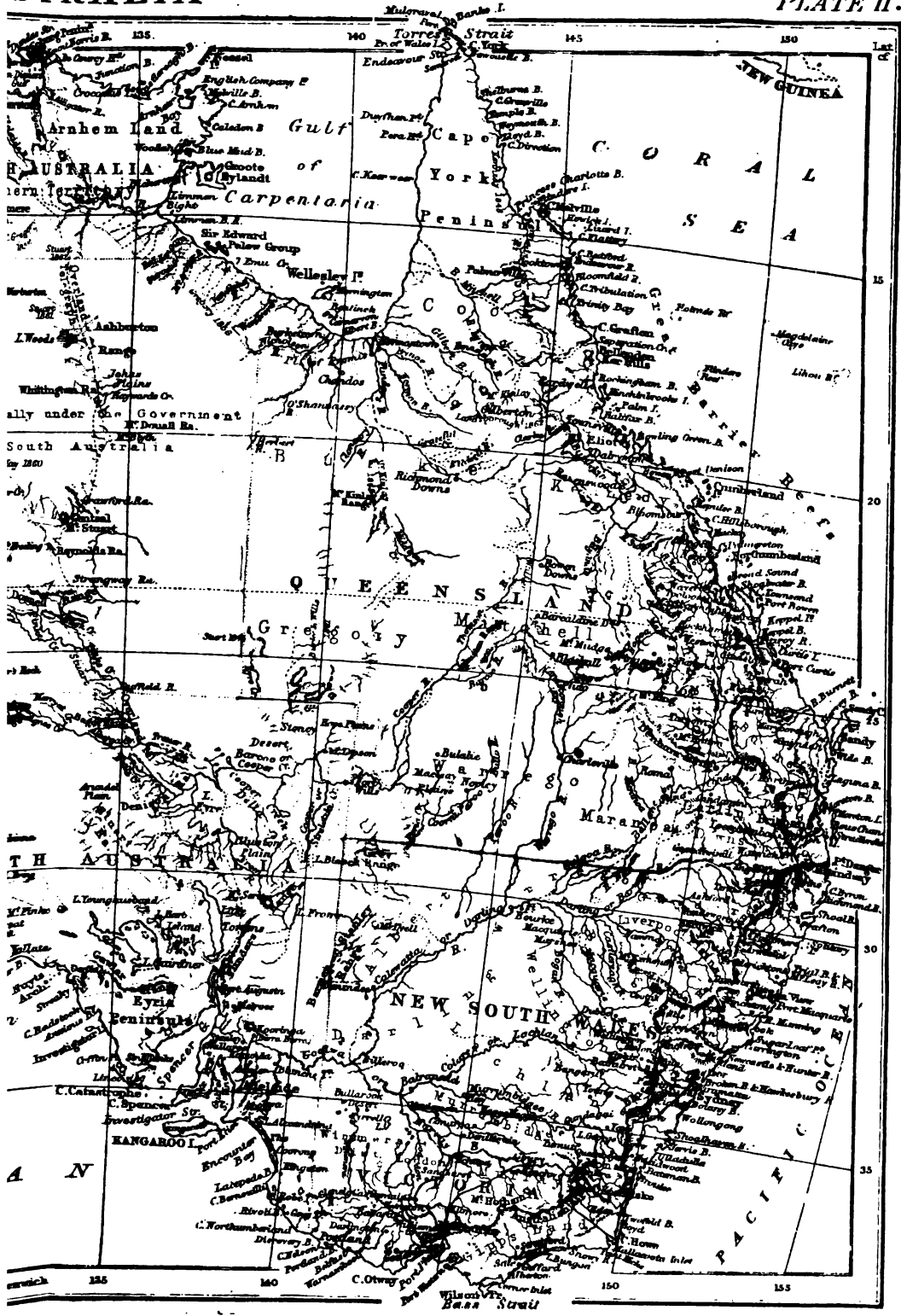



## A U S T R A L I A

**A**USTRALIA or NEW HOLLAND, the largest island-continent of Australasia, is situated within  $10^{\circ} 47'$  and  $39^{\circ} 11'$  S. lat., and  $113^{\circ}$  and  $153^{\circ} 30'$  E. long. It measures 2500 miles in length from west to east, by 1950 miles in breadth from north to south, and contains an area of about 3,000,000 square miles—nearly the same as that of the United States of America, exclusive of Alaska. It is surrounded on the west by the Indian Ocean, and on the east by the South Pacific. In the north it is separated



Sketch Map of Australia.

from New Guinea by Torres Strait, which is 80 miles broad, and from the Eastern Archipelago by Arafura Sea; while on the south Bass Strait, 140 miles wide, separates it from Tasmania. The neighbouring colony of New Zealand lies 1200 miles opposite its south-east coast.

Owing to its position at the antipodes of the civilised world, Australia has been longer a *terra incognita* than any other region of the same extent. Its first discovery is involved in considerable doubt, from confusion of the names which were applied by the earlier navigators and geographers to the Australasian coasts.

The ancients were somehow impressed with the idea of a *Terra Australis* which was one day to be revealed. The Phœnician mariners had pushed through the outlet of the Red Sea to eastern Africa, the Persian Gulf, and the coasts of India and Sumatra. But the geographer Ptolemy, in the 2d century, still conceived the Indian Ocean to be an inland sea, bounded on the south by an unknown land, which connected the *Chersonesus Aurea* (Malay Peninsula) with the promontory of *Prasum* in eastern Africa. This erroneous notion prevailed in mediæval Europe, although some travellers like Marco Polo heard rumours in China of large insular countries to the south-east.

The investigations of Mr R. H. Major make it appear probable that the Australian mainland was known as "Great Java" to the Portuguese early in the 16th century; and the following passage in the *Descriptionis Ptolemaicas Augmentum* of Cornelius Wytfliet, printed at Louvain in 1598, is perhaps the first distinct account that occurs of the country:—"The *Australis Terra* is the most southern of all lands, and is separated from New Guinea by a

narrow strait. Its shores are hitherto but little known, since, after one voyage and another, that route has been deserted, and seldom is the country visited, unless when sailors are driven there by storms. The *Australis Terra* begins at one or two degrees from the equator, and is ascertained by some to be of so great an extent, that if it were thoroughly explored it would be regarded as a fifth part of the world."

It was in 1606 that Torres, with a ship commissioned by the Spanish Government of Peru, parted from his companion Quiros (after their discovery of *Espiritu Santo* and the New Hebrides), and sailed from east to west through the strait which bears his name; while in the same year the peninsula of Cape York was touched at by a vessel called the "Duyfhen" or "Dove" from the Dutch colony of Bantam in Java, but this was understood at the time to form a part of the neighbouring island of New Guinea. The Dutch continued their attempts to explore the unknown land, sending out in 1616 the ship "Endracht," commanded by Dirk Hartog, which sailed along the west coast of Australia from lat.  $26^{\circ} 30'$  to  $23^{\circ}$  S. This expedition left on an islet near Shark's Bay a record of its visit engraved on a tin plate, which was found there in 1801. The "Pera" and "Arnhem," Dutch vessels from Amboyna, in 1618 explored the Gulf of Carpentaria, giving to its westward peninsula, on the side opposite to Cape York, the name of Arnhem Land. The name of Carpentaria was also bestowed on this vast gulf in compliment to Peter Carpenter, then governor of the Dutch East India Company. In 1627 the "Guldene Zeepard," carrying Peter Nuyts to the embassy in Japan, sailed along the south coast from Cape Leeuwin, and sighted the whole shore of the Great Bight. But alike on the northern and southern seaboard, the aspect of New Holland, as it was then called, presented an uninviting appearance.

An important era of discovery began with Tasman's voyage of 1642. He, too, sailed from Batavia; but, first crossing the Indian Ocean to the Mauritius, he descended to the 44th parallel of S. lat., recrossing that ocean to the east. By taking this latter course he reached the island which now bears his name, but which he called Van Diemen's Land, after the Dutch governor of Batavia. In 1644 Tasman made another attempt, when he explored the north-west coast of Australia, from Arnhem Land to the 22d degree of latitude, approaching the locality of Dirk Hartog's discoveries of 1616. He seems to have landed at Cape Ford, near Victoria River, also in Roebuck Bay, and again near Dampier's Archipelago. But the hostile attitude of the natives, whom he denounced as a malicious and miserable race of savages, prevented his seeing much of the new country; and for half a century after this no fresh discoveries were made.

The English made their first appearance on the Australian coast in 1688, when the north-western shores were visited by the famous buccaneer Captain William Dampier, who spent five weeks ashore near Roebuck Bay. A few years later (1697) the Dutch organised another expedition under Vlamingh, who, first touching at Swan River on the west coast, sailed northward to Shark's Bay, where Hartog had been in 1616. Dampier, two years later, visited the same place, not now as a roving adventurer, but with a commission from the English Admiralty to pursue his Australian researches. This enterprising navigator, in the narrative of his voyages, gives an account of the trees, birds, and reptiles he observed, and of his encounters with the natives. But he found nothing to invite a long stay. There was

yet another Dutch exploring squadron on that coast in 1706, but the results were of little importance.

It was Captain Cook, in his voyages from 1769 to 1777, who communicated the most important discoveries, and first opened to European enterprise and settlement the Australasian coasts. In command of the bark "Endeavour," 370 tons burden, and carrying 85 persons, amongst whom were Sir Joseph Banks and Dr Solander, returning from the Royal Society's expedition to observe the transit of Venus, Cook visited both New Zealand and New South Wales. He came upon the Australian mainland in April 1770, at a point named after Lieutenant Hicks, who first sighted it, on the shore of Gipps' Land, Victoria, S. lat. 38°, E. long. 148° 53'. From this point, in a coasting voyage not without peril when entangled in the barrier reefs of coral, the little vessel made its way up the whole length of the eastern side of Australia, rounding Cape York, and crossing Torres Strait to New Guinea. In his second expedition of Australasian discovery, which was sent out in 1773, Cook's ship, the "Resolute," started in company with the "Adventure," commanded by Captain Furneaux. The two vessels separated, and Cook went to New Zealand, while Furneaux examined some parts of Tasmania and Bass Strait. The third voyage of Cook brought him, in 1777, both to Tasmania and to New Zealand.

Next to Cook, twenty or thirty years after his time, the names of Bass and Flinders are justly honoured for continuing the work of maritime discovery he had so well begun. To their courageous and persevering efforts, begun at their private risk, is due the correct determination of the shape both of Tasmania and the neighbouring continent. The French admiral Entrecasteaux, in 1792, had made a careful examination of the inlets at the south of Tasmania, and in his opinion the opening between Tasmania and Australia was only a deep bay. It was Bass who discovered it to be a broad strait, with numerous small islands. Captain Flinders survived his friend Bass, having been associated with him in 1798 in this and other useful adventures. Flinders afterwards made a complete survey in detail of all the Australian coasts, except the west and north-west. He was captured, however, by the French during the war, and detained a prisoner in Mauritius for seven years.

The shores of what is now the province of Victoria were explored in 1800 by Captain Grant, and in 1802 by Lieutenant Murray, when the spacious land-locked bay of Port Phillip was discovered. New South Wales had already been colonised, and the town of Sydney founded at Port Jackson in 1788. West Australia had long remained neglected, but in 1837, after the settlement at Swan River, a series of coast surveys was commenced in H.M.S. "Beagle." These were continued from 1839 to 1843 by Mr Stokes, and furnished an exact knowledge of the western, north-western, and northern shores, including four large rivers.

*Inland Exploration.*—The geographical position of the Australian continent had now been sufficiently determined, and what remained for discovery was sought, not as hitherto by coasting along its shores and bays, but by striking into the vast tract of *terra incognita* that occupied the interior. The colony of New South Wales had been founded in 1788, but for twenty-five years its settlers were acquainted only with a strip of country 50 miles wide, between the Blue Mountains and the sea-coast, for they scarcely ever ventured far inland from the inlets of Port Jackson and Botany Bay. Mr Bass, indeed, once while waiting for his vessel, made an attempt to cross the Blue Mountains, and succeeded in discovering the River Grove, a tributary of the Hawkesbury, but did not proceed further. An expedition was also conducted by Governor Hunter along the Nepean

River west of the settlement, while Lieutenant Barellier, in 1802, and Mr Caley, a year or two later, failed in their endeavour to surmount the Blue Mountain range. This formidable ridge attains a height of 3400 feet, and being intersected with precipitous ravines 1800 feet deep, presented a bar to these explorers' passage inland. At last, in 1813, when a summer of severe drought had made it of vital importance to find new pastures, three of the colonists, Messrs Wentworth and Blaxland and Lieutenant Lawson, crossing the Nepean at Emu Plains, gained sight of an entrance, and ascending the summit of a dividing ridge, obtained a view of the grassy valley of the Fish River. This stream runs westward into the Macquarie, which was discovered a few months afterwards by Mr Evans, who followed its course across the fertile plains of Bathurst.

In 1816 Lieutenant Oxley, R.N., accompanied by Mr Evans and Mr Cunningham the botanist, conducted an expedition of great interest down the Lachlan River, 300 miles to the north-west, reaching a point 34° S. lat., and 144° 30' E. long. On his return journey Oxley again struck the Macquarie River at a place he called Wellington, and from this place in the following year he organised a second expedition in hopes of discovering an inland sea. He was, however, disappointed in this, as after descending the course of the Macquarie below Mount Harris, he found that the river ended in an immense swamp overgrown with reeds. Oxley now turned aside—led by Mr Evans's report of the country eastward—crossed the Arbuthnot range, and traversing the Liverpool Plains, and ascending the Peel and Cockburn Rivers to the Blue Mountains, gained sight of the open sea, which he reached at Port Macquarie. A valuable extension of geographical knowledge had been gained by this circuitous journey of more than 800 miles. Yet its result was a disappointment to those who had looked for means of inland navigation by the Macquarie River, and by its supposed issue in a Mediterranean sea.

During the next two or three years public attention was occupied with Captain King's maritime explorations of the north-west coast in three successive voyages, and by explorations of West Australia in 1821. These steps were followed by the foundation of a settlement on Melville Island, in the extreme north, which, however, was soon abandoned. In 1823 Lieutenant Oxley proceeded to Moreton Bay and Port Curtis, the first place 7° north of Sydney, the other 10°, to choose the site of a new penal establishment. From a shipwrecked English sailor he met with, who had lived with the savages, he heard of the river Brisbane. About the same time, in the opposite direction, south-west of Sydney, a large extent of the interior was revealed. The River Murrumbidgee—which unites with the Lachlan to join the great River Murray—was traced by Mr Hamilton Hume and Mr Hovell into the country lying north of the province of Victoria, through which they made their way to Port Phillip. In 1827 and the two following years, Mr Cunningham prosecuted his instructive explorations on both sides of the Liverpool range, between the upper waters of the Hunter and those of the Peel and other tributaries of the Brisbane north of New South Wales. Some of his discoveries, including those of Pandora's Pass and the Darling Downs, were of great practical utility.

By this time much had thus been done to obtain an acquaintance with the eastern parts of the Australian continent, although the problem of what could become of the large rivers flowing north-west and south-west into the interior was still unsolved. With a view to determine this question, Governor Sir Ralph Darling, in the year 1828, sent out the expedition under Captain Charles Sturt, who proceeding first to the marshes at the end of the Macquarie River, found his progress checked by the dense mass of reeds in that quarter. He therefore turned westward,



and struck a large river, with many affluents, to which he gave the name of the Darling. This river, flowing from north-east to south-west, drains the marshes in which the Macquarie and other streams from the south appeared to be lost. The course of the Murrumbidgee, a deep and rapid river, was followed by the same eminent explorer in his second expedition in 1831 with a more satisfactory result. He travelled on this occasion nearly 2000 miles, and discovered that both the Murrumbidgee, carrying with it the waters of the Lachlan morass, and likewise the Darling, from a more northerly region, finally joined another and larger river. This stream, the Murray, in the upper part of its course, runs in a north-westerly direction, but afterwards turning southwards, almost at a right angle, expands into Lake Alexandrina on the south coast, about 60 miles S.E. of the town of Adelaide, and finally enters the sea at Encounter Bay in E. long. 139°.

After gaining a practical solution of the problem of the destination of the westward-flowing rivers, Sir Thomas Mitchell, in 1835, led an expedition northward to the upper branches of the Darling; but the party meeting with a sad disaster in the death of Mr Cunningham, the eminent botanist, who was murdered by the natives on the Bogan River, further exploration of that region was left to be undertaken by Dr Leichardt, nine years later, and by the son of Sir Thomas Mitchell. Meantime, from the new colony of Adelaide, South Australia, on the shores of Gulf St Vincent, a series of adventurous journeys to the north and to the west was commenced by Mr Eyre, who explored a country much more difficult of access, and more forbidding in aspect, than the "Riverina" of the eastern provinces. He performed in 1840 a feat of extraordinary personal daring, travelling all the way along the barren sea-coast of the Great Australian Bight, from Spencer Gulf to King George's Sound. Mr Eyre also explored the interior north of the head of Spencer Gulf, where he was misled, however, by appearances to form an erroneous theory about the water-surfaces named Lake Torrens. It was left to the veteran explorer, Sturt, to achieve the arduous enterprise of penetrating from the Darling northward to the very centre of the continent. This was in 1845, the route lying for the most part over a stony desert, where the heat (reaching 131° Fahr.), with scorching winds, caused much suffering to the party. The most northerly point reached by Sturt on this occasion was about S. lat. 24° 25'. His unfortunate successors, Burke and Wills, travelled through the same district sixteen years later; and other expeditions were organised, both from the north and from the south, which aimed at learning the fate of these travellers, as well as that of Dr Leichardt. These efforts completed our knowledge of different routes across the entire breadth of Australia, in the longitude of the Gulf of Carpentaria; while the enterprising journeys of MacDouall Stuart, a companion of Sturt, obtained in 1862 a direct passage from South Australia northward to the shores of the Malayan Sea. This route has been utilised by the construction of an overland telegraph from Adelaide to the northern coast.

A military station having been fixed by the British Government at Port Victoria, on the coast of Arnhem Land, for the protection of shipwrecked mariners on the north coast, it was thought desirable to find an overland route between this settlement and Moreton Bay, in what then was the northern portion of New South Wales, now called Queensland. This was the object of Dr Leichardt's expedition in 1844, which proceeded first along the banks of the Dawson and the Mackenzie, tributaries of the Fitzroy River, in Queensland. It thence passed farther north to the Burdekin, ascending to the source of that river, and turned westward across a table-land, from which there was

an easy descent to the Gulf of Carpentaria. Skirting the low shores of this gulf, all the way round its upper half to the Roper, Leichardt crossed Arnhem Land to the Alligator River, which he descended to the western shore of the peninsula, and arrived at Port Victoria, otherwise Port Essington, after a journey of 3000 miles, performed within a year and three months. In 1847 Leichardt undertook a much more formidable task, that of crossing the entire continent from east to west. His starting point was on the Fitzroy Downs, north of the River Condamine, in Queensland, between the 26th and 27th degrees of S. latitude. But this eminent explorer had not proceeded far into the interior before he met his death, his last despatch dating from the Cogoon, April 3, 1848. In the same region, from 1845 to 1847, Sir Thomas Mitchell and Mr E. B. Kennedy explored the northern tributaries of the Darling, and a river in S. lat. 24°, named the Barcoo or Victoria, which flows to the south-west. This river was more thoroughly examined by Mr A. C. Gregory in 1858. Mr Kennedy lost his life in 1848, being killed by the natives while attempting to explore the peninsula of Cape York, from Rockingham Bay to Weymouth Bay.

Among the performances of less renown, but of much practical utility in surveying and opening new paths through the country, we may mention that of Captain Banister, showing the way across the southern part of West Australia, from Swan River to King George's Sound, and that of Messrs Robinson and G. H. Haydon in 1844, making good the route from Port Phillip to Gipps' Land with loaded drays, through a dense tangled scrub, which had been described by Strzelecki as his worst obstacle. Again, in West Australia there were the explorations of the Arrow-smith, the Murchison, the Gascoyne, and the Ashburton Rivers, by Captain Grey, Mr Roe, Governor Fitzgerald, Mr R. Austin, and the brothers Gregory, whose discoveries have great importance from a geographical point of view.

These local researches, and the more comprehensive attempts of Leichardt and Mitchell to solve the chief problems of Australian geography, must yield in importance to the grand achievement of Mr Stuart in 1862. The first of his tours independently performed, in 1858 and 1859, were around the South Australian lakes, namely, Lake Torrens, Lake Eyre, and Lake Gairdner. These waters had been erroneously taken for parts of one vast horse-shoe or sickle-shaped lake, only some twenty miles broad, believed to encircle a large portion of the inland country, with drainage at one end by a marsh into Spencer Gulf. The mistake, shown in all the old maps of Australia, had originated in a curious optical illusion. When Mr Eyre viewed the country from Mount Deception in 1840, looking between Lake Torrens and the lake which now bears his own name, the refraction of light from the glittering crust of salt that covers a large space of stony or sandy ground produced an appearance of water. The error was discovered, after eighteen years, by the explorations of Mr Babbage and Major Warburton in 1858, while Mr Stuart, about the same time, gained a more complete knowledge of the same district.

A reward of £10,000 having been offered by the Legislature of South Australia to the first man who should traverse the whole continent from south to north, starting from the city of Adelaide, Mr Stuart resolved to make the attempt. He started in March 1860, passing Lake Torrens and Lake Eyre, beyond which he found a pleasant, fertile country till he crossed the M'Donnell range of mountains, just under the line of the tropic of Capricorn. On the 23d of April he reached a mountain in S. lat. nearly 22°, and E. long. nearly 134°, which is the most central marked point of the Australian continent, and has been named Central Mount Stuart. Mr Stuart did not finish his task on

this occasion, on account of indisposition and other causes. But the 18th degree of latitude had been reached, where the watershed divided the rivers of the Gulf of Carpentaria from the Victoria River, flowing towards the north-west coast. He had also proved that the interior of Australia was not a stony desert, like the region visited by Sturt in 1845. On the first day of the next year, 1861, Mr Stuart again started for a second attempt to cross the continent, which occupied him eight months. He failed, however, to advance further than one geographical degree north of the point reached in 1860, his progress being arrested by dense scrubs and the want of water.

Meanwhile, in the province of Victoria, by means of a fund subscribed among the colonists and a grant by the Legislature, the ill-fated expedition of Messrs Burke and Wills was started. It made for the Barcoo, with a view to reach the Gulf of Carpentaria by a northerly course midway between Sturt's track to the west and Leichardt's to the east. The leading men of the party were Mr Robert O'Hara Burke, an officer of police, and Mr William John Wills, of the Melbourne observatory. Messrs Burke and Wills, with two men named Gray and King, left the others behind at the Barcoo on 16th December 1860, and proceeded, with a horse and six camels, over the desert traversed by Sturt fifteen years before. They got on in spite of great difficulties, past the M'Kinley range of mountains, S. lat. 21° and 22°, and then reached the Flinders River, which flows into the head of the Gulf of Carpentaria. Here, without actually standing on the sea-beach of the northern shore, they met the tidal waters of the sea. On February 23, 1861, they commenced the return journey, having in effect accomplished the feat of crossing the Australian continent. Unhappily, three of the party perished on the road home. Gray, who had fallen ill, died on the 16th of April. Five days later, Burke, Wills, and King had repossessed the desert to the place on Cooper Creek (the Barcoo, S. lat. 27° 40', E. long. 140° 30'), where they had left the depot, with the rest of the expedition. Here they experienced a cruel disappointment. The depot was abandoned; the men in charge had quitted the place the same day, believing that Burke and those with him were lost. The main body of the expedition, which should have been led up by a Mr Wright, from Menindie, on the Darling, was misconducted and fatally delayed. Burke, Wills, and King, when they found themselves so fearfully left alone and unprovided in the wilderness, wandered about in that district till near the end of June. They subsisted miserably on the bounty of some natives, and partly by feeding on the seeds of a plant called nardoo. At last both Wills and Burke died of starvation. King, the sole survivor, was saved by meeting the friendly blacks, and was found alive in September by Mr A. W. Howitt's party, sent on purpose to find and relieve that of Burke.

Four other parties, besides Howitt's, were sent out that year from different Australian provinces. Three of them, respectively commanded by Mr Walker, Mr Landsborough, and Mr Norman, sailed to the north, where the latter two landed on the shores of the Gulf of Carpentaria, while Mr Walker marched inland from Rockhampton. The fourth party, under Mr J. M'Kinley, from Adelaide, made for the Barcoo by way of Lake Torrens. By these means, the unknown region of Mid Australia was simultaneously entered from the north, south, east, and west, and important additions were made to geographical knowledge. Landsborough crossed the entire continent from north to south, between February and June 1862; and M'Kinley, from south to north, before the end of August in that year. The interior of New South Wales and Queensland, all that lies east of the 140th degree of longitude, was ex-

amined. The Barcoo and its tributary streams were traced from the Queensland mountains, holding a south-westerly course to Lake Eyre in South Australia; the Flinders, the Gilbert, the Gregory, and other northern rivers watering the country towards the Gulf of Carpentaria were also explored. These valuable additions to Australian geography were gained through humane efforts to relieve the lost explorers. The bodies of Burke and Wills were recovered and brought to Melbourne for a solemn public funeral, and a noble monument has been erected to their honour.

Mr Stuart, in 1862, made his third and final attempt to traverse the continent from Adelaide along a central line, which, inclining a little westward, reaches the north coast of Arnhem Land, opposite Melville Island. He started in January, and on April 7 reached the farthest northern point, near S. lat. 17°, where he had turned back in May of the preceding year. He then pushed on, through a very thick forest, with scarcely any water, till he came to the streams which supply the Roper, a river flowing into the western part of the Gulf of Carpentaria. Having crossed a table-land of sandstone which divides these streams from those running to the western shores of Arnhem Land, Mr Stuart, in the month of July, passed down what is called the Adelaide River of North Australia. Thus he came at length to stand on the verge of the Indian Ocean; "gazing upon it," a writer has said, "with as much delight as Balboa, when he had crossed the Isthmus of Darien from the Atlantic to the Pacific." The line crossing Australia which was thus explored has since been occupied by the electric telegraph connecting Adelaide, Melbourne, Sydney, and other Australian cities with London.

A third part, at least, of the interior of the whole continent, between the central line of Stuart and the known parts of West Australia, from about 120° to 134° E. long., an extent of half a million square miles, still remained a blank in the map. But the two expeditions of 1873, conducted by Mr Gosse and Colonel Egerton Warburton, have made a beginning in the exploration of this *terra incognita* west of the central telegraph route. That line of more than 1800 miles, having its southern extremity at the head of Spencer Gulf, its northern at Port Darwin, in Arnhem Land, passes Central Mount Stuart, in the middle of the continent, S. lat. 22°, E. long. 134°. Mr Gosse, with men and horses provided by the South Australian Government, started on April 21 from the telegraph station fifty miles south of Central Mount Stuart, to strike into West Australia. He passed the Reynolds range and Lake Amadeus in that direction, but was compelled to turn south, where he found a tract of well-watered grassy land. A singular rock of conglomerate, 2 miles long, 1 mile wide, and 1100 feet high, with a spring of water in its centre, struck his attention. The country was mostly poor and barren, sandy hillocks, with scanty growth of spinifex. Mr Gosse, having travelled above 600 miles, and getting to 26° 32' S. lat. and 127° E. long., two degrees within the West Australian boundary, was forced to return. Meantime a more successful attempt to reach the western coast from the centre of Australia has been made by Colonel Warburton, with thirty camels, provided by Mr T. Elder, M.L.C., of South Australia. Leaving the telegraph line at Alice Springs (23° 40' S. lat., 133° 14' E. long.), 1120 miles north of Adelaide city, Warburton succeeded in making his way to the De Grey River, West Australia. Overland routes have now been found possible, though scarcely convenient for traffic, between all the widely separated Australian provinces. In Northern Queensland, also, there have been several recent explorations, with results of some interest. That performed by Mr W. Hann, with Messrs Warner, Tate, and Taylor, in 1873,

related to the country north of the Kirchner range, watered by the Lynd, the Mitchell, the Walsh, and the Palmer Rivers, on the east side of the Gulf of Carpentaria. The coasting expedition of Mr G. Elphinstone Dalrymple, with Messrs Hill and Johnstone, finishing in December 1873, effected a valuable survey of the inlets and navigable rivers in the Cape York peninsula. The Endeavour River, in S. lat. 16°, which was visited by Captain Cook a hundred years ago, seems capable of being used for communication with the country inland. A newly discovered river, the Johnstone or Gladys, is said to flow through a very rich land, producing the finest cedars, with groves of bananas, nutmeg, ginger, and other tropical plants. The colonial geologists predict that the north-east corner of Australia will be found to possess great mineral treasures. At the opposite extremity of the continent, its south-west corner, a tour lately made by Mr A. Forrest, Government surveyor, from the Swan River eastward, and thence down to the south coast, has shown the poorness of that region. The vast superiority of eastern Australia to all the rest is the most important practical lesson taught by the land-exploring labours of the last half century.

*Physical Description.*—The continent of Australia, with a circumference of nearly 8000 miles, presents a contour wonderfully devoid of inlets from the sea, except upon its northern shores, where the coast line is largely indented. The Gulf of Carpentaria, situated in the north, is enclosed on the east by the projection of Cape York, and on the west by Arnhem Land, and forms the principal bay on the whole coast, measuring about 6° of long. by 6° of lat. Further to the west, Van Diemen's Gulf, though much smaller, forms a better protected bay, having Melville Island between it and the ocean; while beyond this Queen's Channel and Cambridge Gulf form inlets about S. lat. 14° 50'. On the north-west of the continent the coast line is much broken, the chief indentations being Admiralty Gulf, Collier Bay, and King Sound, on the shores of Tasman Land. Western Australia, again, is not favoured with many inlets—Ermouth Gulf and Shark Bay being the only bays of any size. The same remark may be made of the rest of the sea-board; for, with the exception of Spencer Gulf, the Gulf of St Vincent, and Port Phillip, on the south, and Moreton Bay, Hervey Bay, and Broad Sound, in the east, the coast line is singularly uniform.

The conformation of the interior of Australia is very peculiar, and may perhaps be explained by the theory of the land having been, at a comparatively recent period, the bed of an ocean. The mountain ranges parallel to the east and west coasts would then have existed as the cliffs and uplands of many groups of islands, in widely scattered archipelagoes resembling those of the Pacific. The singular positions and courses of some of the rivers lend force to this supposition. The Murray and its tributaries, the Murrumbidgee, the Lachlan, and the Darling, rising from the mountains on the east coast, flow inwards so far that they were at one time supposed to issue in a central sea. They do, in fact, spend their waters in a large shallow lake; but this is not far from the south coast, and is provided with an outlet to the ocean. The Macquarie and the Lachlan merge in extensive swamps, and their beds in the dry season become a mere chain of ponds. This agrees with the idea that the whole country was a sea-bottom, which has scarcely yet assumed the character of permanent dry land, while another proof consists in the thinness and sterility of the soil in the lowlands.

Along the entire line of the east coast there extends a succession of mountain ranges from Portland, in Victoria, to Cape York in the extreme north, called in different parts the Australian Grampians, the Australian Alps, the Blue Mountains, the Liverpool Range, and other names. These

constitute, like the Andes of South America, a regular Cordillera, stretching from north to south 1700 miles in length, with an average height of 1500 feet above the sea. The rivers flowing down the eastern slope, having but short courses before they reach the sea, are of a more determined character than those which take a westerly and inland direction. They cut their way through the sandstone rocks in deep ravines; but from their tortuous and violent course, and from the insufficient volume of water, they are unfit for navigation. Very few of them traverse more than 200 miles, inclusive of windings, or pass through any district extending more than 50 miles inland. It is different with the Murray, flowing westward, which has a course of 1100 miles, traversing a space from east to west measuring 8° of longitude. The Murray is navigable during eight months of the year along a great part of its course. This great river, with its tributaries, drains a basin the area of which is reckoned at half a million of square miles. Yet it has no proper outlet to the sea, debouching into a lagoon called Lake Alexandrina, on the sea-coast of Encounter Bay. On the opposite or north-western part of the continent there are several important water-courses. One river, the Victoria, which rises somewhere about 18° or 19° S. lat. and 131° E. long., flows northward to 15° 30' S. lat., where it turns westward. Its bed forms a deep channel through the sandstone table-land, with cliffs 300 feet high, while in width it sometimes extends to half a mile, its depth varying from 50 feet to as many fathoms. The Victoria debouches into Cambridge Gulf, 14° 14' S. lat. and 129° 30' E. long., an estuary 20 miles broad, with a depth of 8 or 10 fathoms. To the westward of this district run two other large rivers, the Prince Regent and the Glenelg, the latter being navigable, with a fertile country on its banks. The Roper, a navigable stream in Arnhem Land, has a width of 500 to 800 yards 40 or 50 miles from its mouth, which is at the Lämnen Bight in the Gulf of Carpentaria. In the more settled and inhabited provinces of Australia there are the Brisbane, the Fitzroy, and the Burdekin, rivers of Queensland; the Glenelg River, of Victoria; and the Swan River, of West Australia. But this continent cannot boast of a Nile, an Indus, or a Mississippi, and the interior suffers from the want of water communication.

*Geology.*—The interior plain of Australia, enclosed by the coast mountain ranges, is a vast concave table of sandstone, with a surface area of 1,500,000 square miles. The sedimentary rock, in some parts, has been washed away or scooped out; but in the opinion of Mr W. H. L. Banken (*Dominion of Australia*, 1874), the edges of the plateau, where highest and least reduced by denudation, are actually formed of this sediment. While the southern margin of the plain consists of walls of sandstone cliffs, extending along the sea-coast, the plateau on the east, south-east, the west, and partly on the north, is bordered by terraced ramparts of mountains. These elevations consist of granite and syenite on the west side, rising from 1000 to 3000 feet in height. On the east side, in New South Wales and Gipps' Land, they rise to a much greater height, attaining 7000 feet at the south-east corner in the Australian Alps. Here, too, the sandstone masses are often violently rent asunder, and mingled with the overflows of igneous matter, forming basalt and trap. On the north side of the continent, except around the Gulf of Carpentaria, the edge of the sandstone table-land has a great elevation; it is cut by the Alligator River into gorges 3800 feet deep.

In examining more particularly the geological structure of eastern Australia, we must take into account the neighbouring island of Tasmania. The late Count Strzelecki, author of the first scientific essay upon the subject, in 1845, after minutely describing all the mountain ranges of

New South Wales, passes on to Wilson Promontory, the most southerly point of Australia, whence he looks seaward at the inlands in Bass's Strait. As he there observes the Tasmanian mountains, with which he is equally familiar, it occurs to him that the whole is the result of identical forces, operating in a direction from north-east to south-west. Such phenomena he ascribes to a series of "volcanoes of elevation," along a vast fissure of the earth, upon the line regarded by him as "the Australian eastern axis of perturbation." These forces he believes to have been exerted, with different degrees of intensity, at four several epochs, which are indicated by the character of the sedimentary rocks, broken through or contorted by the eruptive greenstone and basalt. That eruptive action is seen in the ravines and precipices of the Blue Mountains near Sydney; in the Grose valley, below Mount Hay and its neighbours, Mount King George and Mount Tomah; but still more remarkably in the mountains of Tasmania, viewed from Ben Lomond, within 30 miles of Launceston. The sedimentary deposits of the first epoch are characterised by the presence of mica slate, and of argillaceous and siliceous slate, as well as by the absence of gneiss. Those of the second epoch are found to be arenaceous, calcareous, or argillaceous stratified deposits. The third epoch includes the coal deposits, with their intervening shales and sandstones, including many fossils; while the fourth and last epoch is marked by the occurrence of elevated peaks, and by the remains of land animals found in the limestone caves or in alluvial deposits.

The Rev. W. B. Clarke, of Sydney, again, in a revised treatise published in 1871, expresses a doubt whether the southern range of mountains, extending to Wilson's Promontory, be really a continuation of the main Cordillera of New South Wales. He rather considers this to be prolonged in a westerly direction, taking a bend that way at the Warragong or Snowy Alps, and to be continued within 60 miles of the border of South Australia, which is on the 141st meridian of E. long. The subject is further discussed by Mr R. Brough Smith, of Melbourne, in his essay of 1872 on the mineralogy and rock formations of Victoria. This geologist has also remarked that the Murray, which must have repeatedly shifted its bed and changed its outlet, may have once been a far more powerful stream, flooding a vast tract of the interior, and thus becoming an effective agent in the geological formations of all south-east Australia. It has produced, in Victoria more especially, the Tertiary stratifications which are equivalent to the Pliocene rocks of Europe.

Throughout the whole of eastern Australia, including New South Wales and Queensland, while no tertiary *marines* deposits have been found, there occur many remarkable beds of siliceous sandstone, bearing impressions of ferns and leaves of trees, which are referred to the Tertiary epoch.

An interesting theory is advanced by Mr Clarke to account for the absence of Tertiary deposits on the eastern coast, when they are found on the western and southern coasts of Australia. In the islands of New Caledonia and other Australasian groups, from the Louisiade, near New Guinea, to New Zealand, there is a repetition of Australian geological formations, and there are abundant Tertiary deposits; and this may confirm the supposition that the Australian continent at some period extended farther to the east, and that a vast portion has disappeared under the ocean. To the same hypothetical cause Mr Darwin ascribes the formation of the Great Barrier Reef, stretching along the east coast from S. lat. 22° 23' to Torres Strait, with an interval between it and the land varying from 12 to 140 miles.

With regard to the more remote geological epochs, Australia presents fewer materials for study than the other

continents of our globe. Mr Clarke doubts the origin of some of the more ancient strata mentioned in the "first epoch" of Count Strzalecki, and does not find, either in eastern or in southern Australia, sufficient proof that these regions contain azoic and metamorphic rocks. Large masses of granite occur along the coast, and more extensively in Western Australia. Of the lower Palæozoic there is a great deal of Upper Silurian rock in New South Wales and Queensland, and some in Tasmania. It is in the Lower Silurian formation, as Sir Roderick Murchison predicted, that gold deposits are chiefly found. Rocks of the Devonian period are not yet proved to exist anywhere in Australia, and it is doubtful if any true Permian or Trias, so common elsewhere, have been met with in this continent. The great Carboniferous series is very prominent in New South Wales and in parts of Queensland; it prevails less in Victoria. Coal-beds, of thickness varying from 3 feet to 30 feet, are found associated, both above and below, with fossils resembling those of the Carboniferous strata in Ireland. Their antiquity is proved beyond question, in some districts, as in the valley of the Hawkesbury, where they are overlaid with beds of sandstone, shale, and conglomerate, 1000 feet thick. It has been shown by Mr Daintree that there is a very extensive distribution of the Secondary or Mesozoic rocks in Queensland—the Cretaceous strata, both there and in Western Australia, covering a large area. The Oolitic are more abundant in Western Australia.

The great plains of the interior, and the slopes of the inner mountain ranges, consist largely of deposits of the Tertiary epoch. They occupy an immense area in Victoria and New South Wales, including the Riverina district, which was probably, as Mr Brough Smith considers, levelled and planed down by the ancient vast expansion of the Murray. "The waves of the sea," he remarks, "and the waters of this river, have eaten away mountains of granite and great hills of schist in past times, and placed instead of them a smooth covering of sands and clays." The great basin east of Port Phillip, connected with another basin about Westernport, is underlaid with Mesozoic carbonaceous rocks, upper Miocene, a nodular basalt, and decomposed amygdaloid of older volcanic origin, the quartzose drift of the first Pliocene formations, and some volcanic products of more recent date. Here the Miocene beds abound with fossil leaves of plants belonging to that age. The sands, clays, and gravels of later periods, in the ancient beds of the streams within the Silurian areas, are more or less auriferous. Some of the deeper "leads" of the gold-miner contain fossil fruits and the trunks and branches of trees, which are described by Baron von Müller in the Melbourne official reports of the mining surveyors. In the Ballarat gold-fields the auriferous quartzose gravels are overlaid by flows of lava and vesicular volcanic rocks, while in a neighbouring district south of Ballarat, pebbles and sand are cemented by ferruginous matter into an extremely hard conglomerate.

In eastern Australia, where no Tertiary marine deposits are met with, there are deep accumulations of drift, such as transmuted beds of the Carboniferous formation, porphyry, and basalt, and other igneous rocks, and fragments of the older Palæozoic strata. Many of the drift streams are not only highly auriferous, but contain gems of all kinds. Diamonds, though of small size, have been taken from the Cudgegong River, near Mudgee, in New South Wales, and likewise from the Macquarie River.

In the eastern plains of the interior, embedded in black muddy trappan soil, are found the bones of enormous animals of the marsupial or kangaroo order, as well as birds, fishes, and reptiles. The accumulations of bones in caverns at Wellington, New South Wales, and on the rivers Colo, Macleay, and Goodradigbee, are of great interest.

A femur bone of the *dinornis*, the gigantic extinct bird of New Zealand, has been discovered in the drift on Peak Downs in eastern Australia, at the depth of 188 feet; and this would lead to the belief that land once existed where now the Pacific Ocean separates by a thousand miles two countries of Australasia, whose present animal and vegetable races have so little in common.

*Minerals.*—The useful and precious metals exist in considerable quantities in each of the five provinces of Australia. New South Wales has abundance of gold, copper, iron, and coal, as well as silver, lead, and tin. The mineral riches of Victoria, though almost confined to gold, have been the main cause of her rapid progress. South Australia possesses the most valuable copper mines. Queensland ranks next to the last-named province for copper, and excels her neighbours in the production of tin, while gold, iron, and coal are also found in considerable quantities. In Western Australia mines of lead, silver, and copper have been opened; and there is much ironstone.

The discovery of gold in New South Wales and Victoria took place in 1851, and during the next twenty years Victoria exported 40,750,000 oz. of the precious metal, while New South Wales, from 1851 to 1871, exported nearly 10,000,000 ounces. The Queensland gold mines, since 1860, have displayed increasing promise; up to the end of 1872 they had yielded rather less than 1,000,000 ounces; but much was expected, at a more recent date, from the Palmer River and other districts of the north. The yearly value of the aggregate gold exports of Australia, on the average of fifteen years, has been £10,000,000. Victoria alone has produced gold to the value of £170,000,000. The alluvial gold-fields, in which the early diggers, with the simplest tools, obtained for a short time large quantities of the coveted ore, seem now to be mostly exhausted. It is in the quartz formations of the mountain ranges, or in those at a great depth underground, reached by the sinking of shafts and regular mining operations, that Australian gold is henceforth to be chiefly procured. There are mines in Victoria 1000 feet deep, as at Clunes, and many others from 300 to 600 feet.

The copper mines of Burra Burra, in South Australia, proved very profitable some twenty-five years ago, yielding in a twelvemonth ore to the value of £350,000, and the Moonta mines, in 1872, were scarcely less productive. The province of South Australia, in that year, exported copper to the amount of £800,000. Queensland, in 1873, produced one-fourth that quantity. Tin, an article of great mercantile interest, is divided between Queensland and New South Wales in a frontier district, two-thirds of the extent of which belongs to the Darling Downs, within the last-mentioned province. There is a little tin, also, in some parts of Victoria. Lead, silver, and cinnabar have been obtained not only in New South Wales, but likewise in Western Australia.

The abundance of good iron ore, in convenient vicinity to thick beds of excellent coal, ensures a future career of manufacturing prosperity to New South Wales, and not less to Queensland. The country north and south of Sydney, and west of that city 100 miles inland to the dividing range of mountains, is all of Carboniferous formation. At the mouth of the Hunter River, from the port and town of Newcastle, coal was exported in 1873 to the value of £1,000,000 sterling. The collieries there taken up have an extent of 35,000 acres, but the area of the coal-field is officially estimated at 10,000,000 acres, and the seams are 9 feet to 11 feet thick. The quality of this coal is said to be equal to that of Great Britain for most furnace purposes, and it is generally used by steamships in the Pacific and Chinese navigation. Next in importance are the Wollongong collieries, south of Sydney, and those of

Hartley, Maitland, and Berrima, now connected by railway with the capital.

In each of the places above named there is iron of a superior quality, the working of which to advantage cannot be long delayed. On the Illawarra coast it is found close to the finest bituminous coal, and to limestone. The iron of New South Wales is mostly hematite, and the ironstone contains from 60 to 70 per cent. of ore.

Among other mineral products of the same region are cannel coal and shale yielding kerosene oil. This is a recognised article of export from New South Wales to the other colonies. It is hardly worth while to speak of diamonds, opals, and precious stones, but they are often picked up, though of small size, along the Mudgee and Abercrombie Rivers, and at Beechworth and Daylesford, in Victoria.

*Climate.*—The Australian continent, extending over 28° of latitude, might be expected to show a considerable diversity of climate. In reality, however, it experiences fewer climatic variations than the other great continents, owing to its distance (28°) from the Antarctic circle and (11°) from the equator. There is, besides, a powerful determining cause in the uniform character and undivided extent of its dry interior plain. On this subject Mr Ranken, in his *Dominion of Australia*, remarks—"A basin having its northern portion in the tropics, it acts like an oven under the daily sun. It becomes daily heated; then its atmosphere expands; but such is its immensity that no sufficient supply of moist sea air from the neighbouring oceans can reach it, to supply the vacancy caused by this expansion. Of an almost perfectly flat surface, there is no play for currents of air upon it; only the heat is daily absorbed and nightly radiated. Such is the heat, that in the summer the soil is more like a fire than an oven; the air, if it moves, is like a furnace-blast; and such its extent and sameness, that as great heat may prevail hundreds of miles south as north of the tropics." This continual radiation of heat is sometimes relieved—though not with the regularity of an annual season, indeed rather at uncertain intervals of several years—by the admission of masses of vapour, drawn in from the Pacific or the Indian Ocean. Great masses of clouds, after labouring many months to reach the interior from the sea, succeed in passing over the sea-bound mountains, and spread themselves in floods of rain upon the inland country. The north-west shore, and that of Carpentaria, are favoured with an annual visitation of the monsoons, from December to March, penetrating as far as 500 miles into the continent, where the sands of the desert are driven in wavy heaps by the force of this wind. But South Australia, though it feels a cool sea breeze from the south-west, gets little rain, for lack of any mountain range parallel with the coast to arrest and condense the passing vapours. The yearly rainfall at Adelaide and Gawler is therefore not more than 15 or 20 inches, while at the head of Spencer Gulf it is but 6 or 8. In Victoria and in New South Wales, on the contrary, where a wall of mountain fronts the ocean, most places on the sea-board enjoy a fair allowance of rain. It is 32 inches at Portland, nearly 26 inches at Melbourne; at Sydney and Newcastle, on the east coast, as much as 48 and 44 inches in the year. But at Brisbane, in Queensland, farther north, it amounts to 50 inches; at Rockingham Bay, in latitude 18° S., where the hills are covered with dense forests, the rainfall in 1871 was no less than 90 inches. In every part, however, of this magnificent highland region, the supply of moisture is rapidly diminished by passing inland; so that very little remains to fall on the interior or western slopes of the coast ranges, and to irrigate the interior plains.

With regard to the temperature, the northern regions of the continent being situated within the tropic of Capricorn,

resemble the parts of South America and South Africa, that are situated in corresponding latitudes. The seaward districts of New South Wales seem in this respect to be like Southern Europe. The mean annual temperature of Sydney is 62° 4' Fahr., almost equal to that of Lisbon in Portugal. The inland plains of this colony, however, west of the Blue Mountains, which suffer much from evaporation, experience in summer a heat which rises to 100° Fahr. in the shade, and sometimes as high as 140°. There are highland districts, on the contrary, such as Kiandra, 4640 feet above the sea-level, where frost, snow, and hail are endured through the winter. On the Australian Alps, cold being more intense in the dry air, the limit of perpetual snow comes down to 7145 feet. The days on which rain falls in the coast regions of New South Wales average from 100 to 150 in the year, and the amount from 20 inches to 50 inches, decreasing generally farther inland.

In winter, in New South Wales, the prevalent winds blow from the west, with occasional storms of wind and rain from the eastward; while the autumn months have much cloudy weather, not accompanied by rain. January and February are the hottest months of summer, and July the coldest month of winter.

With regard to the climate of Victoria, Mr Robert Ellery, Government astronomer at Melbourne, in his report of 1872, furnishes exact information. The mean annual temperature at Melbourne during fourteen years was 57°·6, and that of the whole province 56°·8, including stations 2000 feet or 1400 feet above the sea-level at Daylesford and Ballarat. This is equivalent to the mean annual temperature of Marseilles and Florence, in the northern hemisphere, but the climate of Melbourne is much more equable than that of the Mediterranean shores. The lowest temperature yet recorded has been 27°, or 5° below the freezing point; the highest, 111° in the shade, occurring during one of the hot winds, called "brickfielders," which, loaded with dust, occasionally blow for a few hours in summer. At Sandhurst, 778 feet above the sea, the greatest extremes of temperature yet observed were 117° and 27°·5; at Ballarat the extreme of winter cold was 10° below freezing.

The amount of humidity in the air is liable to great and rapid variations in the summer months. It is sometimes reduced as much as 60 per cent. within a few hours, by the effect of hot dry winds. But this is compensated by an access of moisture upon a change of wind. The annual average rainfall at Melbourne, which for thirty years is stated at 25·66 inches, does not seem less than that of places in similar latitudes in other parts of the world. Yet it proves inadequate, because of the great amount of evaporation, estimated by Professor Neumayer at 42 inches.

The spring season in Victoria, consisting of the months of September, October, and November, is genial and pleasant, with some rain. The summer—December, January, and February—is generally hot and dry, though its first month is sometimes broken by storms of cold wind and heavy rain. In February the north winds assume the character of siroccos, and bush-fires often devastate the grassy plains and forests of the inland country. The autumn months—March, April, and May—are, in general, the most agreeable; and at this season vegetable life is refreshed, and puts forth a growth equal to that of the spring. The winter is June, July, and August, with strong, dry, cold winds from the north, alternating with frequent rain from the opposite quarter; there is little ice or snow, except in the mountain districts.

*Botany.*—A probable computation of the whole number of distinct vegetable species indigenous to Australia and

Tasmania has been made by Baron Ferdinand von Müller, the Government botanist at Melbourne. He believes that, omitting the minute fungi, there will not be found above 10,000 species of Australian plants. The standard authority upon this subject, so far as it could be known sixty years ago, but now requiring to be completed and extended, was the *Prodromus Floræ Novæ Hollandiæ*, published in 1810 by Mr Robert Brown of the British Museum. Besides making personal observations from 1802 to 1805, he had classified the collections procured by Sir Joseph Banks when Captain Cook's ship visited the eastern shore. Upon that occasion, in 1769, the name of Botany Bay was given to an inlet near Port Jackson, from the variety of new specimens found there. Baron von Müller's Report of 1857 on the researches made by him alone in the North Australian exploring expedition under Mr Gregory, exhibits 2000 new species, representing more than 800 genera, which belong to 160 different orders. He could discover no new natural order, or fundamental form of the vegetable kingdom, in a minute examination of the flora of Arnhem Land, the country around the Gulf of Carpentaria, and the Victoria River, but 60 genera were found that had not been noticed by any earlier Australian botanist.

The eastern parts of this continent, New South Wales and Queensland, are very much richer, both in their botany and in their zoology, than any other parts of Australia. Much was done here for the former science, half a century ago, by Mr Allan Cunningham, whose monumental obelisk fitly stands in the Botanic Garden at Sydney. In general, the growth of trees on the north and north-west coasts is wanting in size and regularity, compared with their growth in eastern Australia. To the last-mentioned region, for instance, the pines are entirely confined; here the Moreton Bay pine, and Bunya Bunya pine, of the genus *Araucaria*, growing to 150 feet in height, yield excellent timber. The red cedar, the iron bark, the blue gum-tree, and others useful to the carpenter, belong likewise to the eastern highlands. The *Casuarina*, or she-oak, is found on the shores of Carpentaria and in the interior, but not on the banks of the Victoria River to the north-west. Of the *Eucalyptus*, or gum-tree, Australia has 400 species; but the one most uniformly distributed is the *Eucalyptus rostrata* or *acuminata*, called the flooded gum-tree; its timber is durable, and takes a fine polish. Rosewood, tulip-wood, sandal-wood, and satin-wood, with other materials for the cabinetmaker's ornamental work, abound in the forests of Queensland. The forest scenery of the more northerly districts, within the tropics, and onwards to Rockingham Bay, is described as of great luxuriance. It consists of many kinds of large umbrageous trees, some of an Indian type, intermixed with noble araucarias, all matted together in an impervious thicket by lianes of the convolvulus, the calamus, and other plants, climbing or pendent, harbouring in their shade many parasitical orchids and ferns. Such forests overhang the seaward sides of the mountain ranges, where they inhale abundant moisture from the winds of the Pacific Ocean, and feed upon a congenial soil from the decomposition of schistose rocks.

A striking contrast is offered to the view beyond the coast ranges. The interior of Queensland presents either highland downs of basaltic origin, almost bare of trees, but with abundant herbaceous vegetation, good pasture grass, and an immense quantity of vernal, or the Brigalow scrub, merely shrubs and small trees, on a soil of argillaceous sandstone. The sandstone table-lands, again, naked and dry, produce but a few diminutive eucalypti, and sparse tufts of unsteady grasses, while the inland deserts have only the acacia to break the monotony of the scene. The character of the inland flora adds confirmation to the belief that the interior was formerly a marine soil, which

has not yet been deprived of its saline properties. In the districts farthest removed from the action of fresh water, hundreds of miles are covered with such plants as will grow on the sea-shore, e.g., the mesembryanthemum called pig's face or Hottentot fig. Other species belonging to the coastward uplands seem to have been conveyed into the interior by the action of water, as the belts of timber, and of pine or cypress scrub, are always found to extend along the line of direction taken by floods. They grow on sandy ridges, alongside of hollows, or depressed channels. On the north coast, so much of which is flat, and often swampy or sandy, the mangrove flourishes as in other tropical regions.

From the extreme aridity of the climate in most parts of northern Australia, there is a singular absence of mosses and lichens. North-west Australia possesses, in the *Adansonia Gregorii*, or gouty-stem tree, a counterpart of the West African baobab, or monkey-bread tree. It is worthy of remark that, with a few exceptions, the Australian trees are evergreens. They also show a peculiar reverted position of their leaves, which hang vertically, turning their edges instead of their sides towards the sun; and the eucalypti have the peculiarity of shedding their bark annually instead of their leaves. In Australia the native species of lily, tulip, and honeysuckle appear as standard trees of considerable size. The native grasses do not form a continuous and even greensward, as in Europe, but grow in detached clumps or tufts. None of the cereal plants are indigenous, and very few of the fruits or roots that supply human food; but many Australian plants are likely to be valuable for medicinal or chemical manufactures.

This continent, as might be expected, has some of the same botanical families that occupy South Africa, Polynesia, and South America. Its relations in that respect to Europe are shown by Alphonse de Candolle's tabular statements in the *Géographie Botanique Raisonnée*. He gives the exact number of species common to Australia and to France in each of the principal families or natural orders. It appears that of 3614 species of phanerogamic plants in France, only 45 belong to Australia. But it will be sufficient, without citing the numerical details, to quote Baron von Müller's list of the natural orders having the most numerous species of indigenous growth in South Australia. They are here arranged in succession, according to their comparative amounts of specific diversity, those which have the greatest number of species being mentioned first. Of the phanerogamic series, the leguminous and the composite families united form nearly one-fourth. Indeed, the half of the dicotyledonous plants, or exogens, that exist in the sub-tropical districts belong to these two orders. Next come the myrtaceous plants, the ferns, and the grasses; the Proteaceae, which form a conspicuous feature of Australian botany; the Orchidaceae, the epeacid family, and the parsley family, or Umbelliferae; the Diomaceae, a sub-order of the Rutaceae or rue family; the Liliaceae, the Labiate or mint family, the Goodeniaceae, the Scrophulariaceae or figworts, and the Salsolaceae. The Ranunculaceae, the geranium family, the roseaceous plants, and the epeacid group, are not found in Australia north of the tropical line.

*Animals.*—The zoology of Australia and Tasmania presents a very conspicuous point of difference from that of other regions of the globe, in the prevalence of non-placental mammalia. The vast majority of the mammalia are provided with an organ in the uterus, by which, before the birth of their young, a vascular connection is maintained between the embryo and the parent animal. There are two orders, the Marsupialia and the Monotremata, which do not possess this organ. Both these are found in Australia, to which region indeed they are not absolutely confined;

but the marsupials alone constitute two-thirds of all the Australian species of mammals. It is the well-known peculiarity of this order that the female has a pouch or fold of skin upon her abdomen, in which she can place the young for suckling within reach of her teats. The opossum of America is the only species out of Australasia which is thus provided. Australia is inhabited by at least 110 different species of marsupials, which have been arranged in five tribes, according to the food they eat, viz., the root-eaters (wombats), the fruit-eaters (phalangers), the grass-eaters (kangaroos), the insect-eaters (bandicoots), and the flesh-eaters (native cats and rats). Of these tribes the wombats are closely allied to the phalangers, represented by the opossums and flying squirrels, with the native bear, while fossil remains of twenty extinct species have also been found. Of wombats now existing there are four species, all of nearly the same size, seldom exceeding 100 lb in weight. They all burrow in the ground, and their habitat is in New South Wales, Tasmania, and South Australia. There is but one species of the singular animal miscalled the native bear, which is more like a sloth in its habits. Three varieties of brush-tailed opossum are found, but one of them exists only in Tasmania; and there are three ring-tailed varieties in almost every part of Australia. The great flying phalanger (*Petaurista*) is nearly allied to the last-mentioned genus; it exists only in East Australia; as does the small flying phalanger (*Belidone*), which is restricted to mountain districts. The interior of Australia and the west coast are wanting in these species, but two or three of them occur on the north coast. The smallest phalanger (*Acrobata pygmaea*) is less than a mouse, and has a feathery tail. The little *Tarsipes rostratus* is almost toothless, but has a long hairy tongue, which it thrusts into flowers to suck their sweetness.

The kangaroo (*Macropus*) and most of its congeners show an extraordinary disproportion of the hind limbs to the fore part of the body. The rock wallabies again have short tarsi of the hind legs, with a long pliable tail for climbing, like that of the tree kangaroo of New Guinea, or that of the jerboa. Of the larger kangaroos, which attain a weight of 200 lb and more, eight species are named, only one of which is found in West Australia. There are some twenty smaller species in Australia and Tasmania, besides the rock wallabies and the hare kangaroos; these last are wonderfully swift, making clear jumps eight or ten feet high. To this agility they owe their preservation from the prairie fires, which are so destructive in the interior during seasons of drought. In the rat kangaroo there is not the same disproportion of the limbs; it approaches more nearly to the bandicoot, of which seven species exist, from the size of a rat to that of a rabbit. The carnivorous tribe of marsupials, the larger species at any rate, belong more to Tasmania, which has its "tiger" and its "devil." But the native cat, or *dasyurus*, is common to every part of Australia. Several different species of pouched rats and mice, one or two living in trees, are reckoned among the flesh-eaters. Fossil bones of extinct kangaroo species are met with, which must have been of enormous size, twice or thrice that of any species now living.

We pass on to the other curious order of non-placental mammalia, that of the Monotremata, so called from the structure of their organs of evacuation with a single orifice, as in birds. Their abdominal bones are like those of the marsupials; and they are furnished with pouches for their young, but have no teats, the milk being distilled into their pouches from the mammary glands. Australia and Tasmania possess two animals of this order,—the echidna, or spiny ant-eater (hairy in Tasmania), and the *Platypus anatinus*, the duck-billed water-mole, otherwise named the *Ornithorhynchus paradoxus*. This odd animal is provided

with a bill or beak, which is not, like that of a bird, affixed to the skeleton, but is merely attached to the skin and muscles.

Australia has no apes, monkeys, or baboons, and no ruminant beasts. The comparatively few indigenous placental mammals, besides the dingo, or wild dog—which, however, may have come from the islands north of this continent—are of the bat tribe and of the rodent or rat tribe. There are four species of large fruit-eating bats, called flying foxes, twenty of insect-eating bats, above twenty of land-rats, and five of water-rats. The sea produces three different seals, which often ascend rivers from the coast, and can live in lagoons of fresh water; many cetaceans, besides the "right whale" and sperm whale; and the dugong, found on the northern shores, which yields a valuable medicinal oil.

The birds of Australia in their number and variety of species (reckoned at 690) may be deemed some compensation for its poverty of mammals; yet it will not stand comparison in this respect with regions of Africa and South America in the same latitudes. The black swan of West Australia was thought remarkable when discovered as belying an old Latin proverb. There is also a white eagle. The vulture is wanting. Sixty species of parrots, some of them very handsome, are found in Australia. The emu, a large bird of the order Cursores, or runners, corresponds with the African and Arabian ostrich, the rhea of South America, and the cassowary of the Moluccas and New Guinea. In New Zealand this order is represented by the apteryx, as it formerly was by the gigantic moa, the remains of which have been found likewise in Queensland. Of the same species as the birds of paradise is the graceful *Mamura superba*, or lyre bird, with its tail feathers spread in the shape of a lyre. The mound-raising megapodes, the bower-building satin-birds, and several others, display peculiar habits. The honey-eaters present a great diversity of plumage. There are also many kinds of game birds, pigeons, ducks, geese, plovers, and quails.

The ornithology of New South Wales and Queensland is more varied and interesting than that of the other provinces.

As for reptiles, Australia has a few tortoises, all of one family, and not of great size. The "leathery turtle," which is herbivorous, and yields abundance of oil, has been caught at sea off the Illawarra coast so large as 9 feet in length. The saurians or lizards are numerous, chiefly on dry sandy or rocky ground in the tropical region. The great crocodile of Queensland is 30 feet long; there is a smaller one, 6 feet long, to be met with in the shallow lagoons of the interior. The monitor, or fork-tongued lizard, which burrows in the earth, climbs, and swims, is said to grow to a length of 8 or 9 feet. This species, and many others, do not extend to Tasmania. There are about twenty kinds of night-lizards, and many which hibernate. One species can utter a cry when pained or alarmed, and the tall-standing frilled lizard can lift its forelegs, and squat or hop like a kangaroo. There is also the *Moloch horridus* of South and West Australia, covered with tubercles bearing large spines, which give it a very strange aspect. This and some other lizards have power to change their colour, not only from light to dark, but in some parts from yellow to grey or red. Dr Gray, of the British Museum, has described fifty species of Australian lizard.

The snakes are reckoned at sixty-three species, of which forty-two are venomous, but only five dangerous. North Queensland has many harmless pythons. There are forty or fifty different sorts of frogs; the commonest is distinguished by its blue legs and bronze or gold back; the largest is bright green; while the tree-frog has a loud shrill voice, always heard during rain.

The Australian seas and rivers are inhabited by many

fishes of the same genera as exist in the southern parts of Asia and Africa. Of those peculiar to Australian waters may be mentioned the arripis, represented by what is called among the colonists a salmon trout. A very fine freshwater fish is the Murray cod, which sometimes weighs 100 lb; and the golden perch, found in the same river, has rare beauty of colour. Among the sea fish, the snapper is of great value as an article of food, and its weight comes up to 50 lb. This is the *Pagrus unicolor*, of the family of Sparidae, which includes also the bream. Its colours are beautiful, pink and red with a silvery gloss; but the male as it grows old takes on a singular deformity of the head, with a swelling in the shape of a monstrous human-like nose. These fish are caught in numbers outside Port Jackson for the Sydney market. Two species of mackerel, differing somewhat from the European species, are also caught on the coasts. The so-called red garnet, a pretty fish, with hues of carmine and blue stripes on its head, is much esteemed for the table. The *Trigla polyommata*, or flying garnet, is a greater beauty, with its body of crimson and silver, and its large pectoral fins, spread like wings, of a rich green, bordered with purple, and relieved by a black and white spot. Whiting, mullet, gar-fish, rock cod, and many others known by local names, are in the lists of edible fishes belonging to New South Wales and Victoria. Much interesting and valuable information upon Australian zoology will be found in a recent essay by Mr Gerard Krefft, curator and secretary of the museum at Sydney, and in the Count de Castelnau's report on the fishes of Victoria at the International Exhibition of 1873.

*Aborigines.*—The Papuan, Melanesian, or Australasian aborigines exhibit certain peculiarities which are not found in the African negro, to which race they otherwise present some similarity. In the Australasian the forehead is higher, the under jaw less projecting, the nose, though flat and extended compared with that of the European, is less depressed than in the African. His lips are thick, but not protuberant; and the eyes are sunken, large, and black. The colour of his skin is lighter—of a dusky hue—than that of the Negro. In stature he equals the average European, but tall men are rare, except in North Queensland; his body and limbs are well shaped, strongly jointed, and highly muscular. The hind parts are not, as in the African, excessively raised; and while the calf of the leg is deficient, the heel is straight. The natives of Papua have woolly spirally-twisted hair. Those of Tasmania, now exterminated, had the same peculiarity. But the natives of the Australian continent have straight or curly black hair. The men wear short beards and whiskers.

Their mental faculties, though probably inferior to those of the Polynesian copper-coloured race, are not contemptible. They have much acuteness of perception for the relations of individual objects, but little power of generalisation. No word exists in their language for the general terms tree, bird, or fish; yet they have invented a name for every species of vegetable and animal they know. The grammatical structure of some North Australian languages has a considerable degree of refinement. The verb presents a variety of conjugations, expressing neatly all the moods and tenses of the Greek. There is a dual, as well as a plural form in the declension of verbs, nouns, pronouns, and adjectives. The distinction of genders is not marked, except in proper names of men and women. All parts of speech, except adverbs, are declined by terminal inflections. There are words for the elementary numbers, one, two, three; but "four" is usually expressed by "two-two;" then "five" by "two-three," and so on. They have no idea of decimals. The number and diversity of separate languages, not mere dialects, is truly bewildering. Tribes of a few hundred people, living within a few



miles of each other, have often scarcely a phrase in common. This is more especially observed in New South Wales, a country much intersected by dividing mountain ranges. But one language is spoken all along the Rivers Murray and Darling, while the next neighbours of the Murray tribes, on both sides, are unable to converse with them.

It is, nevertheless, tolerably certain that all the natives of Australia belong to one stock. There appears reason to believe that their progenitors originally landed on the north-west coast, that of Cambridge Gulf or Arnhem Land, in canoes drifting from the island of Timor. They seem then to have advanced over the continent in three separate directions. By one route they moved, in the course of ages, directly across to the south coast, near the head of the Great Bight, Spencer Gulf, and the Gulf of St Vincent. Another division followed the west coast to Swan River, and round by King George's Sound. The third and most important body, turning eastward, crossed the head of the Gulf of Carpentaria, then split and subdivided itself amidst the rivers and highland ranges of Queensland, while some of its tribes crossing the Upper Darling occupied New South Wales, overspread the Riverina, and peopled the south-eastern quarter of Australia. The proofs and arguments upon which this hypothetical distribution is based are set forth by Mr Eyre in his interesting essay on the Australian aborigines (*Discoveries in Central Australia, &c.*, by E. J. Eyre, resident magistrate, Murray River, vol. ii.) It is chiefly the prevalence of some peculiar customs, such as circumcision, or the removal of two upper-jaw teeth at a stated age of adolescence, that seems to mark the common descent of tribes, now widely distant in location, which appear to have belonged to one of the supposed main streams of population. The discontinuance of such customs among the tribes of the other main divisions is plausibly ascribed to local influences. From a comparison of their languages, the diversities of which have been already referred to, it appears that little aid is to be expected from them in ethnological grouping.

The natives of the north-eastern quarter—a tropical region of diversified surface, with many rivers and thick forests, as well as open highlands—are far superior in body, mind, and social habits to those of the rest of Australia. They bear, in fact, most resemblance to their neighbours and kindred in the island of New Guinea, but are still below these in many important respects.

If a general view be taken of the tribes of Australia, and the state in which they existed independently of recent European intercourse, two or three extraordinary defects exhibit themselves. They never, in any situation, cultivated the soil for any kind of food-crop. They never reared any kind of cattle, or kept any domesticated animal except the dog, which probably came over with them in their canoes. They have nowhere built permanent dwellings, but contented themselves with mere hovels for temporary shelter. They have neither manufactured nor possessed any chattels beyond such articles of clothing, weapons, ornaments, and utensils as they might carry on their persons, or in the family store-bag for daily use. Their want of ingenuity and contrivance has, however, undoubtedly been promoted by the natural poverty of the land in which the race settled.

The sole dress of both sexes in their aboriginal state is a cloak of skin or matting, fastened with a skewer, but open on the right-hand side. No headgear is worn, except sometimes a net to confine the hair, a bunch of feathers, or the tails of small animals. The bosom or back is usually tattooed, or rather scored with rows of hideous raised scars, produced by deep gashes at the age when youth comes to manhood or womanhood. Their dwellings, for the most

part, are either bowers, formed of the branches of trees, or hovels of piled logs, loosely covered with grass or bark, which they can erect in an hour, wherever they encamp. But some huts of a more commodious and substantial form were seen by Flinders on the south-east coast in 1799, and by Captain King and Sir J. Mitchell on the north-east, where they no longer appear. The ingenuity of the race is mostly to be recognised in the manufacture of their weapons of warfare and the chase. While the use of the bow and arrow does not seem to have occurred to them, the spear and axe are in general use, commonly made of hard-wood; the hatchets of stone, and the javelins pointed with stone or bone. The peculiar weapon of the Australian is the boomerang, a curved blade of wood, of such remarkable construction, that it swerves from its direct course, sometimes returning so as to hit an object behind the thrower. Their nets, made by women, either of the tendons of animals or the fibres of plants, will catch and hold the strong kangaroo or the emu, or the very large fish of Australian rivers. Canoes of bent bark, for the inland waters, are hastily prepared at need; but the inlets and straits of the north-eastern sea-coast are navigated by larger canoes and rafts of a better construction.

Without claiming permanent ownership of the land, each native tribe was accustomed, till the English squatter came, to enjoy the recognised manorial dominion of its own hunting-ground, perhaps ten or twelve miles square. This was subdivided between the chief heads of families. The affairs of a tribe are ruled by a council of the men past middle age who are still in full vigour of mind and body. One may be their president, but they have no hereditary prince. Their most solemn assemblies take place when the youth undergo one or other of the painful ceremonies of initiation into manhood. In every case of death from disease or unknown causes the sorcerers hold a public inquest, and pretend to ask the corpse how it was killed. Such deaths are invariably inscribed to witchcraft practised by a hostile or envious neighbouring tribe. The bodies of the slain in battle are sometimes eaten, or the fat of the kidneys, at least, is extracted for a feast of victory. But cannibalism in Australia is not confined to the flesh of enemies, nor is it generally associated with an insulting triumph. It is rather, like that reported of the ancient Scythians, a rite of funeral observance, in honour of deceased kindred and friends. The reality of this custom is proved by the testimony of trustworthy English witnesses, who have watched the revolting act. The only idea of a god known to be entertained by these people, is that of Buddai, a gigantic old man lying asleep for ages, with his head resting upon his arm, which is deep in the sand. He is expected one day to awake and eat up the world. They have no religion beyond those gloomy dreams. Their notions of duty relate mostly to neighbourly service and social interest; and they are not all thieves or liars, but are capable of many good deeds. The marriage bond is observed by the wife or wives, the penalty of its violation being death. But chastity upon any other account is a virtue beyond the native conception, though a certain delicacy of feeling in matters of sex is not unknown. The deplorable lack of moral restraint has involved this unhappy race in sufferings which may be easily understood, from their contact with the more reckless and vicious representatives of foreign nations.

The numbers of the native Australians are steadily diminishing. A remnant of the race exists in each of the provinces, while a few tribes still wander over the interior. Altogether it is computed that not more than about 80,000 aborigines remain on the continent.

Perhaps the most complete and trustworthy information on the Australian race is to be found in works published some twenty or thirty-years ago, before the country

was occupied as it now is by the European settler. Mr Eyre's work above referred to, and Captain (afterwards Sir George) Grey's *Discoveries in North-West and Western Australia*, are authorities that may be relied upon.

*Colonial History.*—Of the five Australian provinces, that of New South Wales may be reckoned the oldest. It was in 1788, eighteen years after Captain Cook explored the east coast, that Port Jackson was founded as a penal station for criminals from England; and the settlement retained that character, more or less, during the subsequent fifty years, transportation being virtually suspended in 1839. The colony, however, from 1821 had made a fair start in free industrial progress.

By this time, too, several of the other provinces had come into existence. Van Diemen's Land, now called Tasmania, had been occupied as early as 1803. It was an auxiliary penal station under New South Wales, till in 1825 it became a separate province. From this island, ten years later, parties crossed Bass's Straits to Port Phillip, where a new settlement was shortly established, forming till 1851 a part of New South Wales, but now the richer and more populous colony of Victoria. In 1827 and 1829, an English company endeavoured to plant a settlement at the Swan River, and this, added to a small convict station established in 1825 at King George's Sound, constituted Western Australia. On the shores of the Gulf St Vincent, again, from 1835 to 1837, South Australia was created by another joint-stock company, as an experiment in the Wakefield scheme of colonisation.

Such were the political component parts of British Australia up to 1839. The earlier history, therefore, of New South Wales is peculiar to itself. Unlike the other mainland provinces, it was at first held and used chiefly for the reception of British convicts. When that system was abolished, the social conditions of New South Wales, Victoria, and South Australia became more equal. Previous to the gold discoveries of 1851 they may be included, from 1839, in a general summary view.

The first British governors at Sydney, from 1788, ruled with despotic power. They were naval or military officers in command of the garrison, the convicts, and the few free settlers. The duty was performed by such men as Captain Arthur Phillip, Captain Hunter, and others. In the twelve years' rule of General Macquarie, closing with 1821, the colony made a substantial advance. By means of convict labour roads and bridges were constructed, and a route opened into the interior beyond the Blue Mountains. A population of 30,000, three-fourths of them convicts, formed the infant commonwealth, whose attention was soon directed to the profitable trade of rearing fine wool sheep, first commenced by Mr John M'Arthur in 1803.

During the next ten years, 1821–31, Sir Thomas Brisbane and Sir Ralph Darling, two generals of the army, being successively governors, the colony increased, and eventually succeeded in obtaining the advantages of a representative institution, by means of a legislative council. Then came General Sir Richard Bourke, whose wise and liberal administration proved most beneficial. New South Wales became prosperous and attractive to emigrants with capital. Its enterprising ambition was encouraged by taking fresh country north and south. In the latter direction, explored by Mitchell in 1834 and 1836, lay Australia Felix, now Victoria, including the well-watered, thickly-wooded country of Gipps' Land.

This district, then called Port Phillip, in the time of Governor Sir George Gipps, 1838 to 1846, was growing fast into a position claiming independence. Melbourne, which began with a few huts on the banks of the Yarra Yarra in 1835, was in 1840 a busy town of 6000 inhabitants, the population of the whole district, with the towns of

Geelong and Portland, reaching 12,850; while its import trade amounted to £204,000, and its exports to £138,000. Such was the growth of infant Victoria in five years; that of Adelaide or South Australia, in the same period, was nearly equal to it. At Melbourne there was a deputy governor, Mr Latrobe, under Sir George Gipps at Sydney. Adelaide had its own governors, first Captain Hindmarsh, next Colonel Gawler, and then Captain George Grey. Western Australia progressed but slowly, with less than 4000 inhabitants altogether, under Governors Stirling and Hutt.

The general advancement of Australia, to the era of the gold-mining, had been satisfactory, in spite of a severe commercial crisis, from 1841 to 1843, caused by extravagant land speculations and inflated prices. Victoria produced already more wool than New South Wales, the aggregate produce of Australia in 1852 being 45,000,000 lb; and South Australia, between 1842 and this date, had opened most valuable mines of copper. The population of New South Wales in 1851 was 190,000; that of Victoria, 77,000; and that of South Australia about the same.

At Summerhill Creek, 20 miles north of Bathurst, in the Macquarie plains, gold was discovered, in February 1851, by Mr E. Hargraves, a gold-miner from California. The intelligence was made known in April or May; and then began a rush of thousands,—men leaving their former employments in the bush or in the towns to search for the ore so greatly coveted in all ages. In August it was found at Anderson's Creek, near Melbourne; a few weeks later the great Ballarat gold-field, 80 miles west of that city, was opened; and after that, Bendigo, now called Sandhurst, to the north. Not only in these lucky provinces, New South Wales and Victoria, where the auriferous deposits were revealed, but in every British colony of Australasia, all ordinary industry was left for the one exciting pursuit. The copper mines of South Australia were for the time deserted, while Tasmania and New Zealand lost many inhabitants, who emigrated to the more promising country. The disturbance of social, industrial, and commercial affairs, during the first two or three years of the gold era, was very great. Immigrants from Europe, and to some extent from North America and China, poured into Melbourne, where the arrivals in 1852 averaged 2000 persons in a week. The population of Victoria was doubled in the first twelvemonth of the gold fever, and the value of imports and exports was multiplied tenfold between 1851 and 1853.

The colony of Victoria was constituted a separate province in July 1851, Mr Latrobe being appointed governor, followed by Sir Charles Hotham and Sir Henry Barkly in succession. The more rapid increase of Victoria since that time, in wealth and number of inhabitants, has gained it a pre-eminence in the esteem of emigrants; but the varied resources of New South Wales, and its greater extent of territory, may in some degree tend to redress the balance, if not to restore the character of superior importance to the older colony.

The separation of the northern part of eastern Australia, under the name of Queensland, from the original province of New South Wales, took place in 1859. At that time the district contained about 25,000 inhabitants; and in the first six years (as Sir George Bowen, the first governor, observed in 1865) its population was quadrupled and its trade trebled.

It appears, from a general view of Australian progress in the last twenty years, that the provinces less rich in gold than Victoria have been enabled to advance in prosperity by other means. Wool continues the great staple of Australia. But New South Wales, possessing both coal and iron, is becoming a seat of manufactures; while Queens





Apex  
Dulce  
Boy

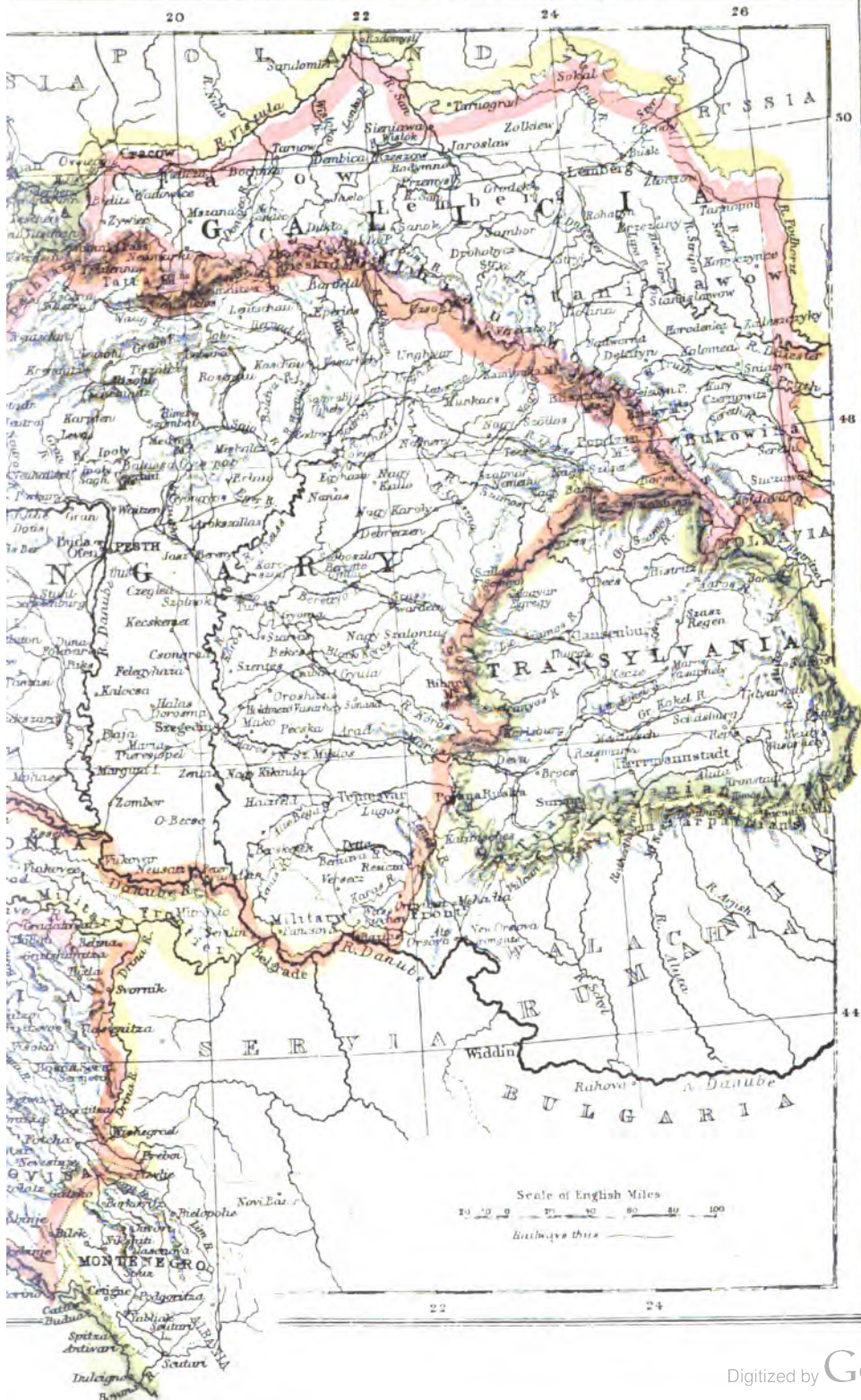



land is also favoured with much mineral wealth, including tin. The semi-tropical climate of the latter colony is suitable for the culture of particular crops, needing only a supply of other than European labour. Meantime South Australia, besides its production of copper and a fair share of wool, has become the great wheat-growing province of the continent.

The separate colonies of Australia are still in a somewhat transitional state, emigration being so continuous, and the country to be yet occupied so extensive. For this and for other reasons, therefore, it may be more fitting to describe the several colonies, with respect to their industrial and social conditions, under their respective names. To enable the reader, however, to judge of the general posi-

tion of the provinces at a recent date, the following statistics are appended:—

Name of Colony.	Estimated Population at Close of 1873.	Revenue of 1873.	Public Debt on Dec. 31, 1873.	Value of Imports for 1873.	Value of Exports for 1873.
Victoria .....	790,092	2,943,091	12,445,722	16,823,888	14,902,464
New South Wales.....	890,375	2,294,712	10,942,415	11,000,288	11,614,829
South Australia.....	198,287	837,646	2,174,900	3,829,830	4,467,860
Queensland .....	144,889	1,120,054	4,786,850	2,881,726	3,042,513
Tasmania .....	104,217	298,728	1,477,000	1,107,167	892,586
Western Australia.....	28,761	154,533	85,000	297,839	364,217
Total for Australian Colonies.....	1,922,603	7,754,671	51,763,487	35,796,296	38,407,498

(R. A.)

## A U S T R I A

**A**USTRIA, or more strictly AUSTRIA-HUNGARY (Ger. *Oesterreich* and *Oesterreich-Ungarn*), is an extensive country in the southern portion of Central Europe, lying between long. 9° and 26° E., and lat. 42° and 51° N. It thus extends through 17 degrees of longitude and 9 degrees of latitude, and has an area of about 240,000 English square miles. With the exception of the islands in the Adriatic, and the narrow projecting tract of Dalmatia, it forms a compact region of country, but of an irregular shape. It is surrounded on all sides by other countries, except where it borders upon the Adriatic, which is about one-fifth of the entire extent of its boundaries. Of the rest, about one-third on the W. and N. is formed by the German empire (Bavaria, Saxony, and Prussia), a third on the S. and E.



Sketch Map of Austria.

by the Turkish empire and the Danubian Principalities, and the remaining third by Russia on the N.E. and Switzerland and Italy on the S.W. The boundaries are formed in some parts by river courses, in others by mountain ranges, and sometimes they extend through an open country. As compared with France, Austria has a form nearly as compact, but its frontiers are by no means so well defined or so strongly protected by natural barriers. It ranks third in extent among the countries of Europe (after Russia and Sweden), and fourth in point of population (after Russia, the German empire, and France).

Austria is, after Switzerland, the most mountainous country of Europe, and about four-fifths of its entire area is more than 600 feet above the level of the sea. The mountains are frequently covered with vegetation to a great elevation. At the base are found vines and maize; on the lower slopes are green pastures, or wheat, barley, and other kinds of corn; above are often forests of oak, ash, elm, &c.; and still higher the yew and the fir may be

seen braving the fury of the tempest. Corn grows to between 3400 and 4500 feet above the level of the sea, the forests extend to 5600 or 6400 feet, and the line of perpetual snow is from 7800 to 8200 feet. In some parts, however, particularly in Tyrol, Styria, Carinthia, and Carniola, the mountains appear in wild confusion, with rugged peaks and bare precipitous sides, forcibly reminding the traveller of Switzerland. Tyrol in particular has, like that country, its cascades, its glaciers, its perpetual snows, and its avalanches.

The Alps occupy the south-west portion of the country, and form its highest lands. They are distinguished by various names, as the Rhetian, Noric, Carnic, Julian, and Dinaric Alps. The Rhetian or Tyrolean Alps enter Tyrol from the Swiss canton of the Grisons, and are the loftiest range in the country, a number of the summits rising to the height of 12,000 feet, and the highest, the Orteler Spitze, attaining a height of 12,814 feet above the level of the sea. They divide into three principal chains, the most southern of which occupies the southern portion of Tyrol, and contains the Orteler Spitze, and others of the loftiest points in the country. The middle or principal chain extends in an easterly direction to the borders of Salzburg and Carinthia, and has many of its peaks covered with perpetual snow. The northern chain is inferior in elevation to the others, and few of its most elevated points reach the snow-line. The Noric Alps are a continuation of the Rhetian eastward, passing through Salzburg, Styria, Carinthia north of the Drave, Lower and Upper Austria, to Hungary, where they gradually sink into the plains. They comprise three chains, a main chain and two lesser chains proceeding northward—the one the Salzburg, the other the Styria-Austrian Alps. The main chain, the Noric Alps in a stricter sense, traverses Salzburg, Carinthia, and Styria, and has a length of about 170 miles, some of its peaks rising to the height of 12,000 feet. The Carnic or Carinthian Alps are also an offshoot of the Rhetian Alps eastward, occupying the south-east of Tyrol, Carinthia, and the north of Carniola. They form several branches, and some of the summits are over 9000 feet high. The Julian or Carniolan Alps extend in a south-easterly direction through Carniola and Croatia. They present little of an Alpine character, and with one or two exceptions nowhere rise to the height of 5000 feet. They are for the most part bare and rugged. The Dinaric Alps are a continuation of the preceding, extending through Croatia and Dalmatia, and resemble them in character. The highest point, Mount Dinara, from which they take their name, is 5956 feet above the level of the sea.

After the Alps, the most important mountain system of Austria is the Carpathians, which occupy its eastern and north-eastern portions, and stretch in the form of an arch

through Silesia, Moravia, Galicia, Hungary, and Transylvania. They have an extent of about 650 miles and are divided into three principal groups—the Hungarian Carpathians, the Carpathian Waldgebirge or Forest Mountains, and the Transylvanian Highlands. The Hungarian Carpathians stretch from west to east, through Hungary, Moravia, Silesia, and Galicia for about 200 miles, and comprise various smaller groups, among which are the Beskides, the Little Carpathians, and the Central Carpathians or the Tetra Mountains. This last group constitutes the highest portion of the Carpathians, having an average elevation of over 6000 feet, and its two principal summits, the Eisthaler Thurm and the Lomnitzer Spitze, having a height of 8378 and 8222 feet respectively. In character it resembles the Alps more than the Carpathians, having rugged precipitous sides, deep chasms, snows, glaciers, cascades, &c. The Waldgebirge, or Forest Mountains, are a series of moderate elevations, for the most part wooded, and stretching for about 160 miles through Hungary, Galicia, and Buckowina, with an average breadth of about 45 miles. They are in general from 3000 to 6000 feet in elevation, the highest point, Pietrossa, rising to 7086 feet. The Transylvanian Highlands extend over Transylvania, a part of Hungary, and the Military Frontier, into Moldavia and Wallachia. They have a length of about 350 miles, and breadth of from 30 to 90. Several of the summits rise to the height of 8000 feet. The sides of the Carpathian mountains are generally covered with forests to a considerable height.

The Hercynian mountain system spreads itself over Bohemia, Silesia, Moravia, and the middle and northern portions of Upper and Lower Austria. It includes the lesser systems of the Bohemian Forest, the Erzgebirge, the Riesengebirge, and the Sudetes. The Bohemian Forest is a series of wooded heights on the confines of Bohemia and Bavaria, and extending south from the Eger to the Danube. Its highest point is 4610 feet above the sea. The Erzgebirge, or Ore Mountains, commence on the left bank of the Elbe, run eastward between Bohemia and Saxony, and terminate near the sources of the White Elster. None of the summits rise to the height of 4000 feet. The Riesengebirge or Giant Mountains are on the confines of Bohemia towards Prussian Silesia, and have their highest point, Schneekoppe or Riessenkoppe, 5330 feet above the sea. The Sudetes is a name sometimes given to all the mountains of Northern Bohemia, but it more properly belongs to that range which runs between Moravia and Prussian Silesia, from the March to the Oder. The highest summit, the Spiegeltzer Schneberg, is 4774 feet high.

The great central chain of the Alps consists of primitive rocks, principally gneiss, mica slate, and granite. Occasionally clay-slate, greywacke, and limestone overlie these rocks. Iron ore is very abundant here, and gold and copper are found. The northern and southern ranges of the Alps are composed of limestone. In the southern range the limestone rests upon gneiss, which crops out in some parts. Iron, copper, lead, and zinc ores, and quick-silver are found in some parts to a large extent. In the northern range the limestone is in some places covered with clay-slate, greywacke, and transition limestone. In the north the limestone is covered with sandstone, which extends in an almost continuous line from the Lake of Constance to the neighbourhood of Vienna. In this district a number of beds of coal are found. The central range of the Carpathians is formed chiefly of gneiss, granite, clay-slate, greywacke, and transition limestone, frequently covered with extensive patches of Tertiary formations. North and south of this are ranges of sandstone mountains, on which diluvial and alluvial deposits are also found. The northern sandstone range is rich in salt; the central

chain abounds in iron and copper ore; and the gneiss and granitic mountains of Hungary and Transylvania are rich in ores of gold and silver. Numerous beds of coal are also found in the later formations. The Bohemian and Moravian mountain system is composed chiefly of gneiss and granite. Basalt, clinkstone, greenstone, and red sandstones are also common. Silver and lead mines are extensively worked, also mines of zinc and iron. Coal is abundant here. The plain and hilly parts of the country belong chiefly to the middle or Miocene period of the Tertiary formation, and comprise sand, gravel, clay-marl, &c.

As the highlands of Austria form part of the great watershed of Europe which divides the waters flowing northward into the North Sea or the Baltic, from those flowing southward or eastward into the Mediterranean or the Black Sea, its rivers flow in three different directions—northward, southward, and eastward. With the exception of the small streams belonging to it which fall into the Adriatic, all its rivers have their mouths in other countries, and its principal river, the Danube, has also its source in another country. This, which after the Volga is the largest river of Europe, rises in the grand duchy of Baden, flows through Würtemberg and Bavaria, and is already navigable when it enters Austria, on the borders of which it receives the Inn, a river which has as large a body of water as itself. It has a course of about 820 miles within the country, which is about 48 per cent. of its entire length. Where it enters it is 898 feet above the level of the sea, and where it leaves only 132 feet. It has thus a fall within the country of 766 feet, and is at first a very rapid stream, but latterly a very slow one. Its affluents, after the Inn, are at first generally small, the principal being the Traun, the Enns, and the March. In Hungary it receives from the Carpathians the Waag, Neutra, Gran, and Eipel; and from the Alps the Drava, the Mur, and the Save. But the principal affluent of the Danube is the Theiss, which rises in the Carpathians, and drains nearly the whole of the eastern half of Hungary. The country drained by the Danube is formed into several basins by the mountains approaching its banks on either side. The principal of these are the Lins and Krems basins, the Vienna basin, and the little and great Hungarian basins. Between this last and the plains of Wallachia, it passes through the narrow rocky channels of Islach, Kasan, and the Iron Door, where the fall is about 41 feet in less than half a mile. The Dniester, which, like the Danube, flows into the Black Sea, has its source in the Carpathians in Eastern Galicia, and pursues a very winding course towards the south-east. It receives its principal affluents from the Carpathians, and drains in Austria a territory of upwards of 12,000 English square miles. It is navigable for about 300 miles. The Vistula and the Oder both fall into the Baltic. The former rises in Moravia, flows first north through Austrian Silesia, then takes an easterly direction along the borders of Prussian Silesia, and afterwards a north-easterly, separating Galicia from Russian Poland, and leaving Austria not far from Sandomir. Its course in Austria is 240 miles, draining an area of 15,500 square miles. It is navigable for nearly 200 miles, and its principal affluents are the Save and the Bug. The Oder has also its source in Moravia, flows first east, and then north-east through Austrian Silesia into Prussia. Its length within the Austrian territory is only about 55 miles, no part of which is navigable. The only river of this country which flows into the North Sea is the Elbe. It has its source in the Riesengebirge, not far from the Schneekoppe, flows first south, then east, and afterwards north-east through Bohemia, and then enters Saxony. Its principal affluents are the Adler, Iser, and Eger, and, most important of all, the Moldau. The last, from the length of its course,



and the quantity of water which it brings down, is entitled to be considered the main stream. It has a course of 260 miles, and is navigable for 190. The Elbe itself has a course within the Austrian dominions of 185 miles, for about 65 of which it is navigable. It drains an area of upwards of 21,000 square miles. The Rhine, though scarcely to be reckoned a river of the country, flows for about 25 miles of its course between it and Switzerland. The principal river of Austria which falls into the Adriatic is the Adige. It rises in the mountains of Tyrol, flows south, then east, and afterwards south, into the plains of Lombardy. Its principal affluent is the Eisack. Of the streams which have their course entirely within the country, and which fall into the Adriatic, the principal is the Isonzo, 75 miles in length, but navigable only for a short distance from its mouth.

The lakes and marshes of Austria are very numerous, and some of them are of great extent. The lakes lie principally in the valleys among the Alps, and the marshes are frequent along the courses of the rivers. The largest lake of Austria is the Balaton, in Hungary, which is about 46 miles in length by 18 in breadth, and, including the swamps in connection with it, covers an area of 500 square miles. The Neusiedler, also in Hungary, is 18 miles in length, by from 4 to 7 in breadth, and covers an area of 106 square miles. Among the many smaller ones the principal are the Traunsee, Attersee, Wörthersee, Mondsee, &c. No other European country equals Austria in the number and value of its mineral springs. No fewer than 1500 of these are reckoned, and they occur principally in Bohemia and Hungary. In the former are Karlsbad, Marienbad, Franzensbad, Teplitz, Püllna, and Seidlitz.

The climate of Austria, in consequence of its great extent, and the great differences in the elevation of its surface, is very various. It is usual to divide it into three distinct zones. The most southern extends to 46° N. lat., and includes Dalmatia and the country along the coast, together with the southern portions of Tyrol and Carinthia, Croatia, Slavonia, and the most southern part of Hungary. Here the seasons are mild and equable, the winters are short (snow seldom falling), and the summers last for five months. The vine and maize are everywhere cultivated, as well as olives and other southern products. In the south of Dalmatia tropical plants flourish in the open air. The central zone lies between 46° and 49° N. lat., and includes Lower and Upper Austria, Salzburg, Styria, Carinthia, Carniola, Central and Northern Tyrol, Southern Moravia, a part of Bohemia, the main portion of Hungary, and Transylvania. The seasons are more marked here than in the preceding. The winters are longer and more severe, and the summers are hotter. The vine and maize are cultivated in favourable situations, and wheat and other kinds of grain are generally grown. The northern zone embraces the territory lying north of 49° N. lat., comprising Bohemia, Northern Moravia, Silesia, and Galicia. The winters are here long and cold; the vine and maize are no longer cultivated, the principal crops being wheat, barley, oats, rye, hemp, and flax. The mean annual temperature ranges from about 59° in the south to 48° in the north. In some parts of the country, however, it is as low as 46° 40' and even 36°. In Vienna the average annual temperature is 50°, the highest temperature being 94°, the lowest 2° Fahr. In general the eastern part of the country receives less rain than the western. In the south the rains prevail chiefly in spring and autumn, and in the north and central parts during summer. Storms are frequent in the region of the South Alps and along the coast. In some parts in the vicinity of the Alps the rainfall is excessive, sometimes exceeding 60 inches. It is less among the Carpathians, where it usually varies from

30 to 40 inches. In other parts the rainfall usually averages from 20 to 24 inches, but in the plains of Hungary it is as low as 16.

From the varied character of its climate and soil the vegetable productions of Austria are very various. It has floras of the plains, the hills, and the mountains; an alpine flora, and an arctic flora; a flora of marshes, and a flora of steppes; floras peculiar to the clay, the chalk, the sandstone, and the slate formations. The number of different species is estimated at 12,000, of which one-third are phanerogamous, or flowering plants, and two-thirds cryptogamous, or flowerless. The crown-land of Lower Austria far surpasses in this respect the other divisions of the country, having about four-ninths of the whole, and not less than 1700 species of flowering plants. Hungary, Bohemia, Moravia, and Galicia are the principal corn-growing regions of the country; and Tyrol, Salzburg, and Upper Styria are the principal pastoral regions.

The animal kingdom embraces, besides the usual domestic animals (as horses, cattle, sheep, swine, goats, asses, &c.), wild boars, deer, wild goats, hares, &c.; also bears, wolves, lynxes, foxes, wild cats, jackals, otters, beavers, polecats, martens, weasels, and the like. Eagles and hawks are common, and many kinds of singing birds. The rivers and lakes abound in different kinds of fish, which are also plentiful on the sea-coast. Among insects the bee and the silkworm are the most useful. The leech forms an article of trade. In all there are 90 different species of mammals, 248 species of birds, 377 of fishes, and more than 13,000 of insects.

Austria comprises five countries, each bearing the name of kingdom—viz., Hungary, Bohemia, Galicia, Illyria, and Dalmatia; one archduchy, Austria; one principality, Transylvania; one duchy, Styria; one margraviate, Moravia; and one county, Tyrol. These are now divided into provinces, which are called *crown-lands*, and of which at present there are 18, 14 being in Austria Proper, and 4 in Hungary. The following table gives the area and civil population of the different crown-lands in 1857 and in 31st December 1869. The first 14 crown-lands constitute Austria Proper, and the remaining 4 form the kingdom of Hungary. Görz, Istria, and Trieste are also known as the Maritime District.

Crown-lands.	Area in English Miles.	Population in 1857.	Population in 1869.		
			Males.	Females.	Total.
Lower Austria.....	7,680	1,681,697	967,067	967,164	1,934,261
Upper Austria.....	4,617	707,400	386,117	378,462	781,579
Salzburg.....	2,767	144,780	72,468	77,942	151,410
Styria.....	8,642	1,064,778	565,209	574,920	1,181,309
Carinthia.....	2,997	392,456	191,519	174,831	366,400
Carniola.....	2,864	451,941	225,000	243,964	468,973
Görz, Istria, & Trieste	3,074	530,978	282,399	292,796	662,979
Tyrol and Vorarlberg	11,387	861,018	437,241	449,666	878,907
Bohemia.....	19,997	4,704,325	2,433,629	2,673,440	5,104,069
Moravia.....	8,385	1,867,696	946,206	1,048,691	1,997,897
Silesia.....	1,991	443,918	245,374	269,097	511,581
Galicia.....	30,312	4,897,470	2,602,618	2,747,498	5,418,016
Bukovina.....	4,022	446,920	243,919	264,045	511,964
Dalmatia.....	4,923	604,499	300,169	322,617	642,796
Hungary.....	82,806	9,900,785	5,499,462	4,618,161	11,117,623
Transylvania.....	21,159	1,994,797	1,043,145	1,050,655	2,103,777
Croatia and Slavonia.....	7,431	876,008	468,962	501,544	997,606
Military Frontier.....	13,919	1,064,222	604,991	693,380	1,300,371
<b>Total.....</b>	<b>238,637</b>	<b>31,929,954</b>	<b>17,467,806</b>	<b>16,167,360</b>	<b>33,635,166</b>

A more recent report states that the population of Austria Proper had risen from 26,310,000 in 1869 to 30,970,000 in 1873—the male population having increased from 9,810,000 to 10,200,000, and the females from 16,400,000 to 10,770,000. The most thickly populated crown-land is Silesia; the most thinly, Salzburg.

The civil population of Austria in 1818 amounted to 29,769,263, in 1830 it had increased to 34,082,469, in 1842 to 35,295,957, in 1857 to 37,339,012, and in 1869 to 35,634,858. Between the two last dates it had lost its Lombardo-Venetian territories, with more than 5,000,000

inhabitants. In Austria Proper the number of births in 1869 was 812,474, of which 419,374 were males and 393,100 females; 699,047 were legitimate, and 113,427 illegitimate, and 17,114 were still-born. The number of deaths among children up to 5 years of age was 281,643—152,294 being males, and 129,349 females. The number of marriages that took place during that year was 208,787, of which 164,018 were between parties neither of whom had been previously married; 8670 between parties both of whom had been previously married; 23,533 between widowers and unmarried females, and 12,566 between widows and unmarried males. The total number of deaths during 1869 was 583,995, of which 302,104 were males and 281,891 females. Of these the ages of 28 males and 40 females are given as over 100 years. Violent deaths carried off 5988 males and 1939 females, of whom 1110 males and 265 females had committed suicide, 244 males and 82 females were murdered, and 4 males executed. In Austria Proper there were 738 cities and large towns, 1270 market towns, 52,919 villages, and 2,766,314 inhabited and 121,045 uninhabited houses. In Hungary there were 189 cities and large towns, 769 market-towns, 16,373 villages, and 2,450,213 houses. The cities containing more than 100,000 inhabitants in 1869 were Vienna (833,855), Pesth (201,911), and Prague (157,275). Seven cities contained between 50,000 and 100,000 inhabitants; 42 between 20,000 and 50,000; and 90 between 10,000 and 20,000.

The population of Austria is made up of a number of distinct races, differing from each other in manners, customs, language, and religion, and united together only by living under the same government. The most numerous race is the German, amounting to 9,000,000, and forming 25 per cent. of the entire population. They are found more or less in all the crown-lands, but are most numerous in Lower and Upper Austria, Salzburg, Styria, Carinthia, and Northern Tyrol. The different Slavonic races number together 16,540,000, or 46 per cent. The principal Slavonic races are,—in the north, the Czechs and Moravians (4,480,000), who, together with the Slovaks in the Western Carpathians (1,940,000), form 18 per cent. of the entire population, and the Poles (2,370,000) and the Ruthens (3,360,000) occupying Galicia; and in the south, the Slovans (1,220,000), the Croats (1,520,000), and the Serbians (1,651,000). The northern Slavonians are found chiefly in Bohemia, Moravia, Galicia, and the north of Hungary; the southern in Carniola, Dalmatia, Croatia, Slavonia, and the Military Frontier. The Magyars or Hungarians occupy chiefly Hungary and Transylvania, and number 5,590,000, or 16 per cent. of the whole population. The Bumáni or Wallachians number 2,940,000, or over 8 per cent.; the Jews, 1,105,000, or 3 per cent.; the Italians, 515,000, or 1·4 per cent.; and the gipsies, 140,000. The rest consist of Armenians, Bulgarians, Albanians, Greeks, &c.

Austria has always remained strongly attached to the Roman Catholic Church. Her sovereigns, however, have in general resisted the temporal pretensions of the popes, and reserved to themselves certain important rights, such as the imposing of taxes on church property, the nomination of bishops and archbishops, and the option of restricting, or even prohibiting, the circulation of Papal bulls. About two-thirds of the people, or nearly 24,000,000, profess the Roman Catholic religion. If, however, we deduct the kingdom of Hungary and Galicia, where less than one-half of the people are Roman Catholics, the proportion in the rest of the country is much increased. In some parts the proportion to the entire population is as high as 90 to 98 per cent. The Greek Catholics number in Austria Proper 2,342,168 (almost all in Galicia), and in Hungary 1,599,628. The Eastern Greek Church numbers 461,511 adherents in Austria, and 2,589,319 in Hungary. Of the

Protestant denominations, the Lutherans are more numerous in the western half of the empire, the Calvinists in the eastern. The numbers are—in Austria Proper, Lutherans, 252,327, and Calvinists, 111,935; in Hungary, Lutherans, 1,365,835, Calvinists, 2,143,178. The principal other religions are the Jewish, 1,375,861 (nearly half of them in Galicia); Armenian, 10,133; Unitarian, 55,079 (nearly all in Transylvania). The Catholic Church (including the Greek and Armenian Catholics) has 11 archbishops, 24 suffragan bishops, 2 vicariate bishops, and 1 military bishop, in Austria Proper, and 5 archbishops and 23 bishops in Hungary. Altogether there are about 34,000 ecclesiastics, and 950 convents, with 8500 monks and 5700 nuns. The Oriental Greek Church has, in Austria Proper, 3 bishops (1 in Buckowina and 2 in Dalmatia), and in Hungary, the patriarch of Karlówitz, the archbishop of Herrmannstadt, and 8 bishops, with, in all, 4000 priests, and 40 convents, with 300 monks.

Previous to 1848 Austria was very far behind in the matter of education; but since that time great improvements have been effected, and an entire change has taken place. This subject now receives the greatest attention; schools of all kinds have been established throughout the country, improved systems of teaching have been introduced, and instruction is open to all without regard to class or creed at a very small cost, or even gratuitously. It still continues, however, to be in great measure under the control of the priests, and many of the teachers are ecclesiastics. The Roman Catholic religion forms an essential part of the instruction in all schools, except those for special subjects. The Oriental Greek and Protestant Churches have, as a rule, their own common schools, and where this is not the case, they have to send their children to the Catholic schools. The Jews also, in places where they have no special schools, are obliged to send their children to Christian schools.

The various educational institutions may be arranged under four classes—(1.) The lower or common schools; (2.) The higher or middle schools; (3.) The universities, academies, and technical schools; (4.) The special schools (for particular branches of science or art). All children from 6 to 15 years of age are bound to attend the common schools. This law, however, would appear to be not very strictly carried out, for of the number of 2,219,917 children who ought to have been attending the common schools in Austria Proper in 1868, the number given as actually at school is only 1,691,349, or about 76 per cent. This percentage, moreover, varies greatly in different parts of the country, being in some, as Tyrol, Salzburg, Moravia, and Upper and Lower Austria, as high as 98 or 100, and in Styria and Carinthia from 93 to 96; in others, as in Carniola, only 66, in the Maritime District 47, Dalmatia 23, Galicia 27, Buckowina 20. The proportion for the whole of Hungary is 88 per cent., and it is higher in the western than in the eastern half of the kingdom. The number of common schools in Austria in 1868 was 15,054, with 32,137 male and 2814 female teachers, 12,225 of the former being ecclesiastics, and 1036 of the latter nuns; in Hungary the number of schools was over 16,000, and of teachers 28,000. In connection with many of these schools there are training institutions for teachers, industrial schools for girls, and trade and agricultural schools for boys. The middle schools are the gymnasiums, real-gymnasiums, and real-schools. A complete gymnasium provides for a course of eight years' study, divided into two parts of four years each. The lower course not only prepares for the higher, but is also complete in itself for those who do not wish to advance farther. The branches of study include Latin, Greek, and modern languages, geography, history, religion, mathematics, natural history, physics, writing, drawing, singing, and gymnastics. In passing from one class to another the scholars undergo a very searching examination. The real-schools, or middle industrial schools, have been established since 1848, and are designed to impart technical knowledge, and afford a suitable training to those intending to follow industrial pursuits. They are divided into two courses of three years each, a lower and an upper—the former serving not only as a preparation for the latter, but forming also an independent course, fitting for the lower kinds of industrial occupations. The branches taught include geography, history, arithmetic, mathematics, writing, book-keeping, exchange, natural history, technology, drawing, &c. The real-gymnasiums are a class of institutions intermediate between these two, partaking of the

character of both. In Austria Proper there were, in 1871, 92 gymnasia, with 1647 teachers (618 being ecclesiastical) and 26,109 scholars; 31 real-gymnasias, with 378 teachers (66 ecclesiastical) and 45,290 scholars; and 33 real-schools, with 777 teachers (91 ecclesiastical) and 15,632 scholars. In Hungary there were 142 gymnasia, 1 real-gymnasium, and 25 real-schools, having in all 33,000 scholars. There are six universities in Austria Proper (Vienna, Grätz, Innsbruck, Prague, Cracow, Lemberg), and one in Hungary (Pesth), with, in all, 707 professors and 10,900 students. Each university (except Lemberg, which has no medical faculty) has faculties for Roman Catholic theology, law and political economy, medicine and surgery, and philosophy. The theological and law courses occupy four years each, the medical five, and the philosophical three. Of the students, 40 per cent. were at the university of Vienna, 18 at Pesth, 16 at Prague, 10 at Lemberg, and 6½ at Grätz. Of the 6332 students attending the six Austrian universities, 1888 were receiving free instruction and 924 were stipendiats, and in addition to this, 682 were paying only half fees. The technical high schools or academies have for their object the imparting of a high scientific education. The students generally enter them from the upper real-schools, and the complete technical course extends over five years. There are eight of these institutions in Austria Proper, having in all 234 professors and teachers, and 3179 scholars, of whom 1501 were receiving free instruction, and 231 were stipendiats. The principal of these is the Polytechnic institution in Vienna, which has 79 professors and teachers, and 732 scholars. Among the special educational institutions may be mentioned about seventy theological seminaries connected with the Catholic Church, and a number of similar institutions connected with the Eastern Greek and Protestant Churches; a rabbinical school (in Presburg); academies for law, mining, navigation, commerce, agriculture, and the management of forests; normal and military schools; schools for surgery and midwifery; veterinary schools, &c. There are also a number of private schools of various kinds, schools for the deaf and dumb and blind, orphan institutions, &c. In connection with the universities and many of the higher educational institutions are to be found libraries, museums of natural history and antiquities, botanic gardens, observatories, chemical laboratories, &c. There also exist numerous learned and scientific societies. The intellectual progress of Austria is, of late years, particularly manifest in the departments of law, medicine, natural science, history, and Oriental languages.

The majority of the people of Austria are engaged in agricultural pursuits or in connection with the forests, the proportion varying in different parts from 50 to 80 per cent. of the entire population. The proportion of those engaged in trade or manufacture varies, amounting to 30 per cent. in Lower Austria, 24 in Bohemia, 23 in Moravia and Silesia, 19 in Upper Austria, 14 in Tyrol, 13 in Salzburg, 11 in Carinthia, 9 in Carniola, 5 in Bukowina, and 4 in Galicia and Dalmatia. In Dalmatia about 8 per cent. of the people are employed in navigation and the fisheries.

The productive land of Austria Proper is estimated at 89·6 per cent. of its superficial area, and that of Hungary at 84·4—making 86·9 per cent. of the whole country. Farther, the arable land in Austria forms 81·6 per cent., the vineyards 0·7, gardens and meadows 11·7, pasturage 14·7, and forests 80·9. In like manner, in Hungary the arable land forms 30·3 per cent., vineyards 1·3, gardens and meadows 12·8, pasturage 13·2, and forests 26·6. The principal product of the arable land is grain, of which the annual yield is over 400,000,000 bushels. Of this about one-fifth is wheat, one-fourth rye, one-fourth oats, one-seventh maize, one-seventh barley, and the rest buck-wheat and millet. The principal grain-producing districts are Hungary, Bohemia, Galicia, Moravia, and Lower and Upper Austria. In agriculture Austria is still behind many other countries, but great improvements have of late years taken place. Flax, hemp, and beet are chiefly found in Silesia, Moravia, Bohemia, and Hungary; hops in Bohemia, and tobacco (which is a state monopoly) only in Hungary, Galicia, and Tyrol. Among the other products may be mentioned pease, beans, potatoes, turnips, rape seed, cabbages, &c. Though the vineyards are not very extensive, a considerable quantity of wine is produced, and some of the Hungarian wines, as Tokay, are justly celebrated. The annual yield of wine is about 375,000,000 gallons, of which 72 per cent. is from Hungary and the neighbouring districts, 6½ from Lower Austria, 5 from Southern Tyrol, 4½ from Styria, 4 from Dalmatia, 3½ from Moravia, and 2 from the Maritime District. The principal garden products are fruit and kitchen vegetables. The best fruit districts are Moravia, Transylvania, Hungary, Bohemia, Upper Austria, and Styria. Certain districts are distinguished for particular kinds of fruit, as Tyrol for apples, Hungary for melons, Dalmatia for figs, pomegranates, olives, &c. In the south of Dalmatia the palm grows in the open air, but bears no fruit. The chestnut, olive, and mulberry trees are common in the south—the olive chiefly in Dalmatia, the Maritime District, and Southern Tyrol; the mulberry tree in Southern Tyrol, the south of Hungary, Slavonia, and Styria. The forests occupy nearly one-third of the productive area of the country, and cover 66,400 English square-miles.

They are much more extensive in the eastern than in the western half of the country, the relative proportions being 62 per cent. in the former, and 33 in the latter. They are found particularly in the region of the Carpathians, and especially in Galicia and Bukowina. The Alpine regions are generally well wooded, as is also the country of the Sudetes. The forests are chiefly of oak, pine, beech, ash, elm, and the like, and are estimated to yield annually over 27,000,000 cords of building wood and firewood.

Austria is distinguished for the number and superiority of its horses, for the improvement of which numerous studs exist over the country. The breeding of horses is more or less extensively carried on in all the crown-lands, but more especially in Hungary, Transylvania, Bukowina, Galicia, Styria, Bohemia, Moravia, and Upper and Lower Austria. The total number of horses in the country in 1870 was 3,525,843, of which 2,158,819 were in Hungary. All kinds of horses are represented, from the heaviest to the lightest, from the largest to the smallest. The most beautiful horses are found in Transylvania and Bukowina, the largest and strongest in Salzburg. The horses of Styria, Carinthia, Northern Tyrol, and Upper Austria are also famous. In Dalmatia, the Maritime District, and Southern Tyrol, horses are less numerous, and mules and asses in a great measure take their place. Of the 13,691 mules in the country, 45 per cent. were in Dalmatia, and 30 per cent. in the Maritime District and Southern Tyrol; and of the 61,831 asses, 28 per cent. were in the former and 21 in the latter. The Hungarian crown-lands contained 2266 mules and 30,482 asses.

Austria cannot be said to be remarkable as a cattle-rearing country. Indeed, except in certain districts, particularly among the Alps, it must be considered to be much behind in this branch of industry. The finest cattle are to be found in the Alpine regions; in other parts the breeds are generally very inferior. The Hungarian crown-lands, however, have of late years been improving in this respect. The country numbered 12,704,405 head of cattle in 1870, of which 5,279,193 were in Hungary, 2,070,572 in Galicia, and 1,602,015 in Bohemia. The cattle of the eastern half of the country considerably outnumbered those of the western; but in quality the latter were far superior to the former. In Hungary and Transylvania there are about 72,000 buffaloes. The rearing of sheep receives a large share of attention, and is carried on to a considerable extent in all the crown-lands, and in some very extensively. Much has been done of late years in the way of improving the breeds, more particularly in Moravia, Silesia, Bohemia, Upper and Lower Austria, and Hungary. The main object has been the improvement of the wool, and with this view the merino and other fine-wooled breeds have been introduced. Some attention, however, is also given to the fattening properties. For mutton, the best sheep are those of Lower Carinthia, the Maritime District, Dalmatia, and the Military Frontier. The sheep are frequently driven from one part of the country to another for the sake of pasture, and even into other countries, as Lombardy, Turkey, and the Danubian Principalities. The number of sheep in the country in 1870 was 20,000,000, of which 15,000,000 were in the kingdom of Hungary. The goat, which has been called the poor man's cow, is also to be found in all parts of the country, but more particularly in the mountainous districts and among the poorer peasantry. The total number in the country in 1870 was 1,553,000, of which 573,000 were in Hungary. Dalmatia, however, is the great country of the goats, where they number 280,456, after which follow Bohemia with 194,278, and Tyrol with 137,698. The number of swine was 6,984,753, of which 4,443,279 were in Hungary. They are naturally most numerous in those crown-lands which contain extensive oak and beech forests, or which have many distilleries. Hence they are mostly found in Hungary, Transylvania, the Military Frontier, Galicia, Styria, and Bohemia.

Bees are extensively kept, particularly in the crown-lands of Lower Austria, Hungary, Galicia, and Transylvania. There were in 1870 15,300,000 bee-hives in the country, yielding 7,750,000 lb of honey and 540,000 lb of wax. The silk-worm is cultivated in certain parts of the southern districts, particularly in Southern Tyrol, which yields 2,200,000 lb of cocoons, being nearly double that of all the rest of the country put together. The rivers and lakes in general abound with fish, which are also plentiful along the coast. In Dalmatia, in particular, fishing constitutes an important branch of industry, affording employment to many of the population. Leeches are common in the swamps, and form a considerable article of export. The average annual value of the produce of the land and forests, including the cattle, and hunting and fishing, is estimated at £212,000,000. The value of the real property, including the cattle and agricultural implements, is given at £782,000,000.

In the extent and variety of its mineral resources Austria ranks among the first countries of Europe. Besides the noble metals, gold and silver, it abounds in ores of more or less richness of iron, copper, lead, and tin; while in less abundance are found zinc, antimony, arsenic, cobalt, nickel, manganese, bismuth, chromium, uranium, tellurium, sulphur, graphite, asphalt, rock-salt, coal, and petroleum. There are also marble, roofing-slata, gypsum, porce-

lain earth, potter's clay, and precious stones. The crown-lands in which mining operations are chiefly carried on are Styria (iron and coal), Carinthia (lead and iron), Carniola (quicksilver), Hungary (gold, silver, copper, iron, and coal), Transylvania (gold and silver), Salzburg (iron), Bohemia (silver, lead, iron, and coal), Moravia (iron and coal), Galicia (salt). The chief places where gold and silver ores are found are—(1.) at Zalatna in Transylvania, on the southern range of the Behar Mountains, where affluents of the Körös and Maros take their rise, in which, as well as in the Theiss and the Danube, gold is also found; (2.) The district of Schemnitz and Kremnitz in Hungary; (3.) Příbram and Joachimthal in Bohemia. Nearly 3,000,000 cwt. of gold and silver ores is obtained annually, from which 64,298 oz. of gold and 1,476,000 oz. of silver are extracted. Of the gold, 54 per cent is obtained in Transylvania, and 44 in Hungary; and of the silver ore, 65 per cent is raised in Hungary, 27 in Bohemia, and 54 in Transylvania. Iron is found more or less in all the crown-lands except Upper Austria, the Maritime District, and Dalmatia; but it is most plentiful and best in quality in Styria and Carinthia. The amount of raw and cast iron annually obtained from the ore raised in the country is 7,400,000 cwt., of which 28 per cent is from Styria, 15 from Carinthia, 12½ from Bohemia, 11½ from Moravia, 16 from Upper Hungary, 6½ from other parts of the kingdom of Hungary, and the remainder from the other crown-lands. The principal place where copper is obtained is the neighbourhood of Schmölnitz in Hungary. The quantity for the whole country amounts to 1,500,000 cwt. of ore, from which 65,000 cwt. of pure metal is obtained. Of this, 80 per cent is from Upper Hungary, 6 from Tyrol, and 4 from Bukovina. Carinthia is particularly rich in lead, and from it more than one-half (52 per cent.) of the entire quantity raised in the country is obtained. Bohemia yields 26 per cent., and Hungary 15. Altogether, 195,000 cwt. of ore, and 114,000 cwt. of pure metal is obtained. Idris in Carniola has, after Almaden in Spain, the richest quicksilver mine in Europe, producing 3900 cwt. of pure metal. Of the rest, Hungary produces 1120 cwt., and Transylvania 450. Tin is found only in Bohemia, which supplies 55,000 cwt. of ore, from which 450 cwt. of tin is obtained. Zinc is found chiefly in the neighbourhood of Craoov, where 146,475 cwt. of ore is raised. Austria is particularly rich in salt. In Galicia there exists a stratum of rock-salt many miles in extent, which is worked at Wieliczka and other places. Similar layers occur in Hungary (Marmaros) and Transylvania (at Thorda). There also exist salt springs in Galicia, in Marmaros, and in Transylvania, from which salt is largely extracted, as it is also to a considerable extent from sea water on the coast. About 3,900,000 cwt. of rock-salt is annually obtained from the mines (of which 22 per cent. is from Galicia, 24 from Marmaros, 24 from Transylvania), from the various salt springs about 2,800,000 cwt., and from the salt-works on the coast 1,400,000 cwt. Austria is possessed of almost inexhaustible stores of coal, and the amount annually raised exceeds 6,000,000 tons, of which 48 per cent. is in Bohemia, 12 in Hungary, 11 in Silesia, 10 in Styria, 6½ in Moravia, 2½ in Galicia, and 1½ in Carniola. Peat and clay are abundant in certain parts of the country; porcelain earth is found in Bohemia and Moravia; white, red, black, and variously-coloured marbles exist in the Alps, particularly in Tyrol and Salzburg; quartz, felspar, heavy spar, rock-crystal, asbestos, &c., are found in various parts; and among precious stones may be specially mentioned the Hungarian opals and the Bohemian garnets. The number of persons employed in the various mines in Austria Proper in 1870 was 75,451, and in the smelting and casting works, 18,867. In addition to these, 9818 persons were employed in the salt-mines and other salt-works. In Hungary 50,148 persons were employed in mining and smelting. The total annual value of the raw materials obtained from the mines is estimated at over 29,000,000, of which nearly one-half is of coal, a fifth of iron, an eighth of gold and silver, and a tenth of rock-salt.

The manufactures of Austria have made great progress during the last twenty years, and now some of them are extensively carried on. They include cotton, flax, hemp, woollen and silk stuffs; gold, silver, iron, lead, copper, tin, and zinc articles; leather, paper, beer, brandy, and sugar; porcelain and earthenware; chemical stuffs; scientific and musical instruments, &c. The manufactures are principally carried on in the western crown-lands, and more particularly in Bohemia, Moravia, Silesia, and Lower Austria. In Galicia and the Hungarian crown-lands the manufactures are comparatively neglected. The principal seats of the cotton, woollen, and linen manufactures are in Moravia, Silesia, Bohemia, and Vienna; of iron and steel wares in Styria and Carinthia; iron in Upper Austria; cast-iron goods in Moravia, Styria, Carinthia, and Bohemia; silk in Vienna; glass and porcelain in Bohemia; beet-root sugar in Bohemia and Moravia; leather in Bohemia, Moravia, Galicia, and Hungary; beer in Bohemia and Lower Austria; brandy in Galicia, Moravia, and Bohemia; cabinet wares and musical instruments in Vienna and Prague; and scientific and surgical instruments in Vienna.

The cotton manufacture has made very rapid progress, and is now one of the most extensive and flourishing in the country. In 1851

the import of cotton was 101,000 cwt., and the export 175; in 1859 the former had risen to 522,000, and the latter to 1270; and in 1870 the former was 1,100,000, and the latter 36,000 cwt. There are 173 spinning factories, with 1,750,000 spindles, in the country, almost all situated in Lower Austria, Bohemia, and Vorarlberg. There are 46 factories, with 550,000 spindles, in Lower Austria, between the Vienna Forest and the Leitha, and beside them are 7 dyeing and printing works. A principal seat of the cotton manufacture is in Northern Bohemia, from the Eger to Reichenberg, where there are no fewer than 80 spinning factories and 25 printing works. Besides these, there are 7 factories at Prague and 1 in Southern Bohemia. In Vorarlberg there are 21 factories, with 200,000 spindles; and in Upper Austria 7 factories and 6 printing works.

The flax and hemp manufacture is one of the oldest in the country, and was long the most important. In consequence, however, of the rapid advancement of the cotton manufacture it is no longer of the same importance as formerly; yet it still affords employment to a great number of persons, and is very generally extended over the country. It is principally carried on as a domestic branch of industry, and in country districts is frequently engaged in as a secondary pursuit by those employed in agricultural labour. The flax is mostly spun by hand, and the weaving confined to the commoner kinds of linen, being chiefly intended for home use. In Bohemia, Moravia, Silesia, and Upper Austria, however, this manufacture is more extensively carried on than in other parts. There are here a number of factories for the spinning of flax, and the finer kinds of linen are manufactured.

The woollen manufacture is also an old established branch of industry, and is actively carried on. It is estimated that about 600,000 cwt. of wool is annually spun; and there are about 230 spinning factories, with upwards of 700,000 spindles. The great seats of the woollen manufacture are in Bohemia, Moravia, Silesia, and Upper Austria. In Bohemia its great seat is in and around Reichenberg, where the annual value of the goods produced is about £1,800,000. In Moravia the principal seats are Brinn (for coarse, and also the finest sorts of cloth), Namiescht, and Iglau. In these two crown-lands is made half of the entire quantity of woollen goods produced in the country. The principal of the other seats are the districts Bielitz in Silesia, Vienna in Lower Austria, and Viktring in Carinthia (for fine goods). Vienna is also distinguished for its manufacture of shawls. The coarser kinds of woollen goods are generally manufactured over the country, and principally in the people's houses, and for home use.

The manufacture of silk stuffs is principally carried on in Vienna, and to a small extent in the north of Bohemia and in the Maritime District. The spinning of silk has its principal seat in Southern Tyrol, where about 550,000 lb are spun annually, besides which about 1,700,000 lb are annually brought from other countries.

The iron and steel manufactures form one of the most important branches of industry, and afford employment to a great number of persons. They are more or less extensively carried on in all the crown-lands, except the Maritime District, Dalmatia, Croatia, and Slavonia; but their principal seats are in Lower and Upper Austria, Bohemia, Moravia, Styria, and Carinthia. One of the most important of these seats is Steier and its neighbourhood, in Upper Austria, where there are about 700 establishments, producing goods—chiefly cutlery, scythes, sickles, firearms, &c.—to the value of £400,000 annually. In Styria there are large ironworks at Maria-Zell and Neuberg; and in Carinthia, at Preval, Buchscheiden, and Ferlach. There are also large ironworks in Lower Austria, Carniola, Tyrol, Bohemia, and Moravia. The making of steam engines and other kinds of machinery is largely carried on in and about Vienna, where there are 36 establishments for this purpose. There are similar establishments in other parts of Lower Austria, in Styria, Bohemia, Silesia, and Bukovina. The Lloyds' Company has also large workshops at Trieste. About 1,100,000 cwt. of iron are annually used in the making of machinery, and about 6,600,000 cwt. in the other iron and steel manufactures, among which may be mentioned cutlery, firearms, files, wire, nails, tinplate, steel pens, needles, &c.

The principal copper-works are at Brixlegg and other places in Tyrol, and in Galicia, Bukovina, and Hungary. The quantity of metal employed is about 40,000 cwt., and the value of the articles annually produced is £280,000. In the lead-works the quantity of metal employed is 65,000 cwt., and the annual value of the goods produced, £100,000. Zinc is manufactured (principally in Bohemia) to the annual value of £50,000, and zinc to that of £2500. The precious metals, gold and silver, are principally worked in the larger towns, particularly Vienna and Prague, and the value of the articles annually produced is about £1,700,000. In addition to this a considerable amount of gold and silver is annually taken up by the mints. The mixed metals are also made and manufactured to a considerable extent, as brass, bell metal, gun metal, pinchbeck, &c.

The glass manufacture has its greatest development in Bohemia, where there are not only the greatest number of works (35 in Northern and 55 in Southern Bohemia), but the wares are also of

very superior quality. Their annual value is about £1,000,000. Knapt in Styria and Moravia there is little glass made in other parts of the country, and that only of the commoner sorts. The manufacture of mirrors is also extensively carried on in Bohemia and some other parts. Bohemia and Moravia are likewise distinguished for their earthen and porcelain wares. The preparation of *chemical stuffs* has been of late years greatly extended, and is now actively carried on. Sulphuric and nitric acids are largely made in Bohemia, Lower Austria, and Silesia; pharmaceutical preparations and perfumes are made chiefly in Vienna, and dye-stuffs in Lower Austria and Bohemia. The manufacture of *woollen articles* is widespread over the country, and affords employment to a great number of persons. The smaller articles, particularly children's toys, are largely made by the peasantry in the mountainous and rural districts, particularly in Tyrol, Salzburg, Upper Austria, and Bohemia. Furniture, waggons, and carriages are made in Vienna and other large towns. There are also several establishments for the manufacture of railway carriages in Vienna and Prague.

The manufacture of mathematical, optical, and surgical instruments, and of physical and chemical apparatus, has of late years risen rapidly into importance, particularly in Vienna and Prague, and now these are to be found among the exports to other countries. Austria is also distinguished for the manufacture of musical instruments, particularly pianos and organs, but also for other stringed and wind instruments. Clock or watch making is not very extensively carried on.

The *leather* manufacture forms an important branch of industry, the value of the goods annually produced being estimated at not less than £10,000,000. It is principally carried on in Lower Austria, Bohemia, Moravia, Galicia, Transylvania, and Hungary. Vienna and Prague are the great centres of the boot and shoe trade, and the gloves made in these towns are considered little inferior to those of France. Saddlery is also largely carried on in these towns, and in Puth.

*Paper-making* has of late made considerable progress in Austria. There are 70 paper machines and 193 paper mills in operation, 20 of the former and 100 of the latter being in Bohemia. The rest are mostly in Lower Austria, Styria, and Fiume. Painting, lithographing, engraving, and map making, are actively carried on in Vienna and some of the other large towns. There are 44 printing and 78 lithographic establishments in Vienna alone.

Austria is noted for its *beer*, particularly that of Vienna and Bohemia. There are about 3200 breweries in the country, of which more than 1000 are in Bohemia. The largest establishments, however, are in Lower Austria, in the neighbourhood of Vienna. The annual quantity of beer made is estimated at about 180,000,000 gallons. Brandy is made largely in Hungary, Galicia, and Bukovina, and to a less extent in Bohemia, Moravia, and Lower Austria. *Rosoglio*, *maraschino*, and other liqueurs, are made in Dalmatia and Moravia.

The manufacture of *sugar* from beet-root is in a very flourishing state, and is rapidly extending. In 1857 there were in Austria Proper 81 sugar-works, consuming 8,300,000 cwt. of beet, which amounts were in 1870 raised to 190 and 24,534,646 respectively. In Bohemia alone there were 126 works, consuming 15,579,000 cwt. of beet. Of the other works, Moravia possessed 45, Silesia 10, Lower Austria 6, Galicia 5. This manufacture is also carried on to some extent in Hungary and Transylvania.

The manufacture as well as the growth of *tobacco* is a government monopoly. There are 22 establishments for the manufacture of tobacco and cigars, employing about 20,000 workpeople. Of these there are 5 in Lower Austria, 3 in Galicia, 2 in Moravia, 2 in Tyrol, and 4 in Hungary. The largest are those of Hainburg in Lower Austria (where about one-sixth of the whole is manufactured), Pöstfeld in Styria, and Sedler in Bohemia. About 70,000,000 lb of tobacco are manufactured annually.

The annual value of the industrial products of Austria is estimated at not less than £130,000,000, of which 33 per cent. falls to the eastern, and 67 per cent. to the western half of the country. Among the crown-lands, 18 per cent. belongs to Bohemia alone, 15 to Lower Austria, 15 to Hungary, 6 to Transylvania and the other Hungarian crown-lands, 11 to Galicia and Bukovina, 10 to Moravia, 6 to Tyrol, 4 to Styria, and 4 to Upper Austria.

Austria is not favourably situated for commerce on account of its inland position, its small extent of sea-coast, and the mountainous character of much of its surface. Its trade was also formerly very much hampered by high duties, and restrictions of various kinds. These, however, have now been very much modified or removed, and its trade has in consequence rapidly improved. Much has been done, too, in the way of making and improving the roads, opening mountain passes, constructing railways, and establishing lines of steamers. In 1874 there were 9880 miles of railway in operation, of which 5755 were in Austria and 8775 in Hungary. Besides these there were about 2000 miles in course of construction. There are also 59,770 miles of highways, of which 70 per cent. are in Austria and 30 in Hungary. Bohemia, in particular, is distinguished for the number and excellence of its roads. The river Danube is

navigable for steamers for its entire length in the country—from Passau to Orsova. Many of its affluents are also navigable for a considerable length, particularly the Theiss, Drave, and Save. The Danube Steam Company possesses 155 steamers, of 13,946 horse-power, and 495 towed boats. There are also steamers on a number of the larger lakes. Altogether, Austria possesses 4340 miles of navigable river and canal communication, of which the greater part (60 per cent.) is in Hungary.

The principal seaports of Austria are Trieste and Fiume, at the head of the Adriatic, the former in the Maritime crown-land, the latter in that of Croatia. The number of vessels that entered the port of Trieste in 1870 was—sailing vessels, laden, 5332; in ballast, 898; total tonnage, 407,606; value of imports, £4,673,170; steamers, laden, 924; in ballast, 900; total tonnage, 552,497; value of imports, £12,586,950. The number of vessels that left was—sailing vessels, laden, 4409; in ballast, 1794; total tonnage, 441,601; value of exports, £3,325,400; steamers, laden, 930; in ballast, 900; total tonnage, 571,176; value of exports, £6,716,940. Trieste is the seat of the Austrian Lloyd's Company, which trades principally with the eastern ports of the Mediterranean, Galatz, Sinope, Smyrna, Beirut, Alexandria, &c. They own 68 steam vessels. The number of vessels that entered the port of Fiume in 1870 was—sailing vessels, laden, 1550; in ballast, 270; total tonnage, 77,499; value of imports, £519,830; steamers, laden, 239; in ballast, 17; total tonnage, 52,671; value of imports, £174,730. The number of vessels that left was—sailing vessels, laden, 1180; in ballast, 622; total tonnage, 88,781; value of exports, £366,790; steamers, laden, 245; in ballast, 1; total tonnage, 52,671; value of exports, £94,840.

The commercial navy of Austria in 1870 comprised 83 steam vessels, of 47,243 tons burden, having 2353 men; 566 large sailing vessels, trading with foreign countries, of 255,930 tons burden, having 5939 men; and 2457 coasting vessels, of 555,318 tons burden, having 7588 men. Besides these, there were 4717 smaller vessels, with 14,475 tons and 12,305 men, employed as lighters, in fishing, &c. The number of trading vessels that entered and left the various ports in 1870 was—entered, sailing vessels, Austrian, laden, 17,564 (tonnage, 486,745); in ballast, 6727 (tonnage, 270,587); foreign, laden, 4360 (tonnage, 263,943); in ballast, 2798 (tonnage, 184,760); steamers, Austrian, laden, 4964 (tonnage, 1,676,095); in ballast, 2597 (tonnage, 409,490); foreign, laden, 179 (tonnage, 138,032); in ballast, 12 (tonnage, 7847). Left—sailing vessels, Austrian, laden, 17,204 (tonnage, 468,093); in ballast, 10,306 (tonnage, 290,581); foreign, laden, 5705 (tonnage, 384,019); in ballast, 1976 (tonnage, 108,995); steamers, Austrian, laden, 4160 (tonnage, 1,408,865); in ballast, 2597 (tonnage, 678,512); foreign, laden, 160 (tonnage, 143,100); in ballast, 32 (tonnage, 21,790). Total entered—Austrian vessels, 34,853 (tonnage, 3,843,307); foreign, 7344 (tonnage, 594,551); left—Austrian, 35,069 (tonnage, 3,841,001); foreign, 7371 (tonnage, 652,904). The total value of the imports was £16,630,150; of the exports, £13,052,250—£7,098,180 of the former, and £3,578,810 of the latter, being in foreign vessels. The principal foreign trade is carried on with Italy, Greece, Turkey, England, Holland, Norway and Sweden, North Germany, Denmark, and North America. The number of vessels belonging to the principal foreign states that entered and left the various ports in 1870, was as follows:—

	Entered.			Left.		
	Vessels.	Tonnage.	Value of Cargo.	Vessels.	Tonnage.	Value of Cargo.
Italian .....	2557	108,149	1,623,790	4508	201,751	1,839,910
Greek .....	823	21,511	466,140	513	24,515	393,299
Turkish .....	294	14,267	164,940	126	12,442	128,510
British .....	213	127,320	3,734,810	175	10,462	1,237,590
Dutch .....	41	8,736	294,710	35	5,770	112,190
Swedish and Norwegian)	30	7,471	264,870	23	6,762	71,990

The principal imports, with their values, were—coffee, £205,370; sugar, £218,950; tobacco, in leaf, £417,670; ditto, manufactured, £457,520; wheat, £211,500; maize, £231,060; flour, £431,840; olive oil, £778,890; iron, raw and wrought, £1,210,570; raw cotton, £1,855,210; cotton yarn, £203,130; cotton goods, £1,375,390; linen goods, £226,470; wool, £266,270; woollen goods, £252,900; machines, £316,010. The principal exports were—coffee, £236,610; sugar, £231,090; manufactured tobacco, £270,610; wheat, £244,410; maize, £244,980; flour, £238,730; olive oil, £614,640; spirits of wine, £234,630; barrel staves, £517,520; building stones, £207,040; raw cotton, £223,750; cotton goods, £2,030,060; wool, £109,490; woollen goods, £249,735; articles of clothing, £212,540; paper, £256,070.

As might be expected from its natural position, the overland foreign trade of Austria is more important than its sea traffic. While the latter amounted to £29,822,400, the former was no less than £55,039,034 (imports, £27,890,181; exports, £27,148,853). Of the overland trade about 74 per cent. is with Germany, 14 with

Turkey, & with Italy, & with Russia, and rather more than with Switzerland. It includes colonial goods, agricultural and garden produce, animals and animal produce, the produce of the mines and manufactures, chemical products, machines, scientific instruments, wine, beer, brandy, &c. Besides these, there is a considerable transit trade through the country, chiefly from the seaports and the eastern borders, towards the north and north-west. It is estimated at about £12,000,000.

The internal trade consists chiefly of the exchange of the products of different parts of the country, more particularly of the agricultural products of the east with the industrial products of the west. Important markets are held at fixed times in the principal towns for the different kinds of produce. Vienna, as being the capital and the seat of so many different branches of industry, and as having ready means of communication with all parts of the country, is the principal seat both of the home and of the foreign trade, and the great resort of merchants and capitalists.

Austria possesses a number of banks, the principal of which are—the National Bank, founded in 1816, and having an active capital of £9,000,000; the Austrian Land-Credit Institute, founded 1864, active capital, £960,000; the Austrian Trade and Manufactures Credit Institute, founded 1855, active capital, £4,000,000; the Anglo-Austrian Bank, founded 1868, active capital, £1,704,500; the Union Bank, founded 1870, active capital, £1,200,000; the Franco-Austrian Bank, founded 1869, active capital, £800,000; the Lower Austrian Discount Company, founded 1853, active capital, £700,000. The National Bank is the only company authorised to issue notes. There are also a number of savings banks and loan institutions of various kinds, as well as numerous societies formed with the view of furthering in various ways industry and commerce. In 1871 there were 3504 post-offices in Austria, and 1688 in Hungary; the number of private letters that passed through the former in that year was 125,614,538, and through the latter, 37,368,139; of newspapers through the former, 51,780,909, and through the latter, 22,808,771. There were also throughout the country 1081 telegraph stations, and 22,536 miles of lines transmitting upwards of 5,000,000 messages during that year.

The head of the Austro-Hungarian monarchy is the emperor and king, who is also the head of the army and of the executive. The succession is hereditary, in the order of primogeniture, in the male line of the house of Hapsburg-Lothringen, or Lorraines; and failing this, in the female line. The monarchy comprises two distinct states—a German or Cisalpine, commonly called Austria, and a Magyar or Transalpine, usually termed Hungary. Each of these has its own parliament, ministers, and government; while the army and navy and foreign relations are common. These are under the direction of a controlling body known as the Delegations, consisting of sixty members for each state, two-thirds being elected by the Lower House, and one-third by the Upper House of each of the parliamentary bodies. They usually sit and vote in two chambers—one for Austria, the other for Hungary; but in the event of disagreement on any question, they meet together, and without further deliberation give their final votes, and the decision thus arrived at is binding on the whole empire. Their resolutions require neither the approval nor the confirmation of the representative assemblies by which they are chosen, but only imperial assent. The executive is vested in three departments—(1), A ministry of foreign affairs; (2), a ministry of war; and (3), a ministry of finance. These are responsible to the Delegations. The Reichsrath, or Parliament of Austria, consists of an Upper and a Lower House. The former, the House of Lords, is composed—(1), of princes of the imperial house who are of age (14 in 1874); (2), of the heads of noble houses of high rank, in whom the dignity is hereditary (56); (3), of the archbishops (10) and of bishops with the rank of princes (7); and (4), of life members nominated by the emperor on account of distinguished services (102). The Lower House, or House of Representatives, is composed of 353 members, elected to represent the different crown-lands by all citizens who are of age and possessed of a small property qualification. The emperor annually convokes the Reichsrath, and nominates the presidents and vice-presidents of each division out of the members. The business of the Reichsrath

embraces all matters of legislation relating to laws, duties, and interests, except such as are specially excluded as belonging to other departments. It also takes up matters connected with trade, commerce, and finance, the post-office, railways, telegraphs, customs, the mint, raising of new loans, imposing of new taxes, budgets, matters relating to military service, &c. The members of either House have the right to propose new laws on matters within their province; but the consent of both Houses, as well as the sanction of the emperor, is required to render them valid. The executive is vested in the president and ministries of the interior, religion and education, finance, commerce, agriculture, national defence, and justice. The ministers form also the Ministerial Council, which is presided over by the emperor or a minister-president.

In addition to the Reichsrath, there are seventeen provincial diets established in different districts of the country for the direction and regulation of local matters, taxation, education, religion, public works, charitable institutions, industry, trade, &c. Each diet is composed of the archbishops and bishops of the Roman Catholic and Greek Catholic Churches, of the rectors of the universities, and of representatives of the great landed estates, of the towns, of chambers of industry and commerce, and of rural communes. The number of members varies according to the size and importance of the districts—from 20 or 30 up to 100 for Moravia, 151 for Galicia, and 241 for Bohemia.

The Hungarian Parliament or Reichstag consists of an Upper and a Lower House,—the former known as the House of Magnates, the latter as the House of Representatives. The Upper House, in 1873, consisted of 3 princes of the reigning house, having estates in the kingdom, 31 archbishops and bishops of the Roman Catholic and Greek Churches, and 381 high officials and peers of the kingdom. The Lower House is composed of representatives elected for three years by citizens of age who pay a certain amount of direct taxes. The number of representatives, in 1873, was 444, of whom 334 represented the counties, rural districts, and towns of Hungary; 75 represented Transylvania; and 35 Croatia and Slavonia. The president and vice-president of the House of Magnates are nominated by the king from among the members; and the president and two vice-presidents of the House of Representatives are elected by the members. The sovereign, though emperor of Austria, is styled "king" in all public documents. The executive is vested in a president and ministries of national defence, the court, finance, interior, religion and education, justice, public works, agriculture, industry and commerce, and for Croatia and Slavonia.

The revenue and expenditure are presented in three distinct budgets:—(1), That of the Delegations for the whole empire; (2), that of the Austrian-Reichsrath for Austria; and (3), that of the Hungarian Reichstag for Hungary. By an arrangement of 1868 Austria pays 70 per cent., and Hungary 30 per cent., towards the common expenditure of the empire. The total expenditure for the whole empire, in 1873, was estimated as follows:—

	Ordinary.	Extraordinary.	Total.
1. Ministry of Foreign Affairs	£424,629	£11,181	£435,810
2. Ministry of War	Army	989,962	989,962
	Navy	231,427	182,654
3. Ministry of Finance	192,098	105	192,203
4. Board of Control	10,409	...	10,409
	£10,367,919	£1,183,902	£11,551,821

The estimated Revenue for the same period was as follows:—

Ministry of Foreign Affairs	£69,750
War	510,141
Finance	258
Board of Control	68
	£580,222
	£580,222

Customs Duties .....	Brought forward,	£280,322
Payments by Hungary on account of Military Frontiers .....		1,556,600
Share of Expenditure falling to Austria (70 p.c.) ..		188,819
" " " Hungary (30 p.c.) ..		6,459,368
		3,768,302
		£11,551,821

The budget of Austria Proper for 1873 was as follows:—

<i>Receipts.</i>	
Direct Taxes .....	£9,084,400
Customs Duties .....	2,314,100
Duties on Articles of Consumption .....	5,876,280
Salt Monopoly .....	1,872,000
Tobacco Monopoly .....	5,812,600
Stamps .....	1,400,000
Judicial Fees .....	3,860,000
State Lottery .....	1,526,000
Octroi .....	374,800
State Property and Mint .....	177,748
Domains and Forests .....	449,800
Mines .....	477,050
Post-Office and Telegraphs .....	1,922,200
Miscellaneous .....	4,861,341
	£39,367,769

<i>Expenditure.</i>	
Imperial Household .....	£615,000
Cabinet Chancery .....	7,221
Reichsrath .....	56,486
Court of the Empire .....	2,300
Council of Ministers .....	59,200
Ministry of the Interior .....	1,838,061
National Defence .....	891,800
Religion and Education .....	1,384,370
Finance .....	8,028,323
Commerce .....	8,262,576
Agriculture .....	1,060,853
Justice .....	1,529,226
Board of Control .....	14,620
Pensions, Grants, and Subsidies .....	2,381,628
Share of Interest on Public Debt .....	9,320,269
Administration of Public Debt .....	748,800
Proportion of Public Expenditure .....	7,799,846
	£38,992,939

The budget for 1874 gives the revenue as £39,329,297, and the expenditure as £39,896,531; and that for 1875, the revenue as £38,942,968, and the expenditure as £38,178,255.

The budget of the kingdom of Hungary for 1873 was as follows:—

<i>Receipts.</i>	
Direct Taxes .....	£4,481,842
Indirect do. ....	7,166,546
State Domains, Mines, Mint, &c. } .....	4,000,031
Post-Office, &c. } .....	
Miscellaneous .....	1,262,652
	£16,911,071

<i>Expenditure.</i>	
Royal Household .....	£265,000
Cabinet Chancery .....	6,139
Reichstag .....	70,000
Council of Ministers .....	85,908
Ministry of the Court .....	36,398
Interior .....	755,713
War .....	896,670
Religion and Education .....	375,217
Justice .....	1,068,147
Agriculture and Commerce .....	1,189,733
Roads, &c. ....	4,775,958
Finance .....	6,468,481
Croatia .....	425,670
Share of Interest on Public Debt .....	3,372,320
Ordinary Expenses .....	2,829,321
Miscellaneous .....	650,264
	£38,220,939

The budget for 1874 gives the revenue as £22,402,790, and the expenditure as £25,673,382, being a deficit of £3,270,592.

Though the Austrian budget for 1873 presents a surplus, there had for many years previously been a large annual deficit, amounting in some years to £6,000,000 or £7,000,000; and the two subsequent years also show a considerable deficiency. Consequently, the public debt has been rapidly increasing. In 1815 the national

debt amounted to £22,500,000, in 1820 to £108,000,000, in 1848 to £125,000,000, in 1857 to £239,000,000, in 1864 to £391,000,000, and in 1874 to £322,800,000, of which £264,000,000 was funded, £22,200,000 redeemable, and £37,600,000 floating debt. By the cession of the Lombardo-Venetian provinces in 1866, Austria was relieved of £2,500,000 of debt affecting those territories. The kingdom of Hungary had also at the end of 1873 a debt of £48,871,783.

Austria is said to have "during the last few years made greater sacrifices to improve the efficiency of her army and obtained greater results than any other nation in Europe. Her military educational establishments and system of training, both elementary and professional, for officers and men, are of a very high order" (Captain W. S. Cooke *On the Armed Strength of Austria*, 1873). A new scheme of army organization was brought into operation in 1869, by which the military forces of the whole empire are divided into the standing army with its reserve, the Landwehr, the Ersatz-reserve, and the Landsturm. The standing army is maintained for the defence of the empire against a foreign foe, and for the preservation of order and security at home. The Landwehr is intended to support the standing army in time of war and for home defence. The Ersatz-reserve is composed of a certain class of conscripts who are destined to fill up the ranks of the standing army in time of war, but in peace remain on permanent furlough. The Landsturm is made up of volunteers who do not belong either to the standing army, the navy, or the Landwehr. It is called out and organized to the extent required when the country is threatened by a hostile invasion, and is intended to support the standing army and Landwehr. Military service is compulsory on all citizens capable of bearing arms. The term of service lasts for twelve years—three in the standing army, seven in the reserve, and two in the Landwehr. The strength of the army in peace is fixed at 252,000 men, to be raised during war to 800,000, of which Austria has to furnish 457,012, and Hungary 342,988. It is composed of 80 regiments of infantry, 41 regiments of cavalry, 18 regiments of artillery, 2 regiments of engineers, 1 regiment pioneers, and other troops. (See *ARMY*, vol. ii. p. 604.) The navy was in 1874 composed of 47 steam-vessels, of 96,700 tons burden and 14,635 horse-power, carrying 395 guns; 17 sailing vessels, of 11,800 tons; and 6 steam tenders, of 1260 tons burden and 366 horse-power. The number of seamen in peace, 5782; in war, 11,632. The naval stations are Pola and Trieste.

The present empire of Austria took its rise in a margraviate founded by Charlemagne, towards the close of the 8th century, in that fertile tract of country lying along the southern bank of the Danube to the east of the River Enns, and now included in Lower Austria. It was called *Ostreich* or *Oesterreich*, the eastern country, from its position relative to the rest of Germany. It continued to be ruled by margraves (Ger. *Markgraf*, lord of the marches) for several centuries, down to the year 1156, when the territory west of the Enns was added to it, and it was raised to a duchy. It subsequently received further accessions of territory, and in 1453 was made an archduchy.

The country of the present archduchy of Austria was in early times inhabited by the Taurisci, a Celtic race, who were afterwards better known as the Norici. They were conquered by the Romans in 14 B.C.; and thereafter a portion of what is now Lower Austria and Styria, together with the municipal city of *Vindobona*, now Vienna, and even then a place of considerable importance, was formed into the province of Pannonia; and the rest of Lower Austria and Styria, together with Carinthia and a part of Carniola, into that of Noricum. Tyrol was included in Rhetia, while north of the Danube, and extending to the borders of Bohemia and Moravia, were the territories of the Marcomanni and the Quadi. These were not unfrequently troublesome to the Romans; and during the greater part of the reign of Marcus Aurelius, from 169 to 180 A.D., they maintained with varying success a harassing war against them. In 174 the Roman army was so nearly cut off by the Quadi that its safety was attributed to a miracle. The emperor died at Vindobona when on an expedition against those troublesome neighbours, and his successor, Commodus, was glad to make peace with them. On the decline of the imperial power these Roman provinces became a prey to the incursions of barbaric tribes,

During the 5th and 6th centuries the country was successively occupied by the Boii, Vandaie, Heruli, Rugii, Goths, Huns, Lombards, and Avari. About 568, after the Lombards had settled in Upper Italy, the River Enns became the boundary between the Bajuvari, a people of German origin, and the Avari, who had come from the east. In 788 the Avari crossed the Enns and attacked Bavaria, but were subsequently driven back by Charlemagne, and forced to retreat as far as the Raab, their country from the Enns to that river being then made a part of Germany. It was taken by the Hungarians in 900, but was again annexed to Germany in 955 by Otho I. In 983 the emperor appointed Leopold I., of Babenberg or Bamberg, margrave of Austria, and his dynasty ruled the country for 263 years. He died in 994, and was succeeded by his son, Henry I., who governed till 1018. In 1156 Austria received an accession of territory west of the Enns, and was raised to a duchy by the Emperor Frederick I. The first duke was Henry Jasomirgott, who took part in the second crusade. He removed the ducal residence to Vienna, and began the building of St Stephen's cathedral. His successor, Leopold V., in 1192, obtained Styria as an addition to his territory, and Frederick II. received possession of Carniola. Frederick, in the latter years of his life, contemplated the erection of Austria into a kingdom, but his sudden death in a battle against the Magyars, in 1246, put an end to the project, and with him the line became extinct.

The Emperor Frederick II. now declared Austria and Styria to have lapsed to the imperial crown, and appointed a lieutenant to govern them on the part of the empire. But claims to the succession were brought forward by descendants of the female branch of the Babenberg line; and after various contests Ottocar, son of the king of Bohemia, gained possession about 1252 of the duchies of Austria and Styria. In 1269 he succeeded to Carinthia, a part of Carniola and Friuli; but he lost all by refusing to acknowledge the Emperor Rudolph of Hapsburg, and eventually fell in battle in an attempt to recover them in 1278.

The emperor now took possession of the country, and appointed his eldest son governor; but subsequently, in 1282, having obtained the sanction of the electors of the empire to the act, he conferred the duchies of Austria and Styria, with the province of Carinthia, on his sons Albert and Rudolph, and thus introduced the Hapsburg dynasty. The brothers transferred Carinthia to Meinhard, count of Tyrol; and in 1283 Albert became sole possessor of Austria, Styria, and Carniola. He increased his possessions considerably by wars with his neighbours, but was murdered at Rheinfelden in 1308, when on an expedition against the Swiss, by his nephew, John of Swabia, whom he had deprived of his hereditary possessions. He was succeeded by his three sons, Frederick, Leopold, Henry, Albert, and Otto. In 1314 Frederick, the eldest, was set up by a party as emperor in opposition to Louis, duke of Bavaria, but was defeated and taken prisoner by his rival in 1322. In 1315 Duke Leopold was defeated in an attempt to recover the forest towns of Switzerland which had revolted from his father. Leopold died in 1326, Henry in 1327, and Frederick in 1330. The two surviving brothers then made peace with the Emperor Louis, and in 1335 they acquired Carinthia by inheritance. On the death of Otto in 1339 Albert became sole ruler. He died in 1358. His son and successor, Rudolph II., finished the church of St Stephen's and founded the university of Vienna, dying childless in 1365. He was succeeded by his two brothers, Albert III. and Leopold III., who in 1379 divided their possessions between them, the former taking the duchy of Austria, the latter Styria and other parts. Leopold fell at Sempach in

1386, but his descendants continued to rule in Styria. Albert acquired Tyrol and some other districts, and died in 1395. He was succeeded by his son, Albert IV., who was poisoned at Znaim in 1404, when on an expedition against Procopius, count of Moravia. Albert V. succeeded his father, and having married the daughter of the Emperor Sigismund, he obtained the thrones of Hungary and Bohemia, and became emperor (Albert II.) in 1438. He died the following year, and was succeeded by his posthumous son Ladislaus, who died without issue in 1457. The Austrian branch of the family thus became extinct, and was succeeded by that of Styria. The crowns of Hungary and Bohemia passed for a time into other hands.

The possession of Austria, which in 1453 had been raised to an archduchy, was for some years a subject of dispute between the Emperor Frederick III. and his brothers, but at length, on the death of Albert in 1463, the emperor obtained sole possession. His son Maximilian, by marrying the daughter of Charles the Bold, acquired the Netherlands in 1477, but on the death of his father in 1493 he succeeded him as emperor, and transferred the government of the Netherlands to his son Philip. He added Tyrol and some parts of Bavaria to his paternal possessions, and made some advances towards the recovery of Hungary and Bohemia. His son Philip, by his marriage with Johanna, daughter of Ferdinand and Isabella, acquired a right to the crown of Spain, but died in 1506. Maximilian died in 1519, and was succeeded by his grandson Charles (son of Philip), who two years before had obtained the Spanish crown, and was now made emperor under the title of Charles V. By treaties dated 1521 and 1524, Charles resigned all his hereditary possessions in Germany, except the Netherlands, to his brother Ferdinand. The latter, by his marriage with Anna, sister of the king of Hungary, acquired right to the kingdoms of Hungary and Bohemia, together with Moravia, Silesia, and Lausatia. His right to Hungary, however, was contested by John Zapolya, waywode of Transylvania, who was elected by a party of the nobles, and was crowned king in 1527. Being unable to cope single-handed with Ferdinand, John sought the aid of the sultan, Soliman II., who in 1529 advanced with a large army to the very gates of Vienna; but after several ineffectual attempts to take the city he raised the siege and returned to Buda. At length, in 1535 an agreement was come to, in terms of which John was allowed to retain the title of king, together with half of Hungary, but his descendants were to be entitled to Transylvania only. John died in 1540, but the people of Lower Hungary were opposed to Ferdinand, and set up the son of their late king against him. In the struggle which ensued the aid of the Turks was again invoked, and the result was that Ferdinand had to agree to pay an annual sum of 30,000 ducats to the sultan for this part of Hungary. Ferdinand was also under the necessity of surrendering Württemberg to Duke Ulrich, on condition of its remaining a fief of Austria and reverting to that country on the extinction of the male line. Notwithstanding this, the possessions of the German line of the house of Austria at this time are estimated at 114,000 square miles. On the abdication of Charles V. in 1556, Ferdinand succeeded to the imperial throne. He died in 1564, leaving directions for the division of his possessions among his three sons. The eldest, Maximilian II., received the imperial crown, together with Austria, Hungary, and Bohemia; the second, Ferdinand, obtained Tyrol and Lower Austria; and the third, Charles, was made master of Styria, Carinthia, Carniola, and Gerts. In 1556 the sultan Soliman again marched at the head of a great army into Hungary, but met with a very determined resistance at Szigeth, before which town he was suddenly cut off by apoplexy.



Peace was concluded with his successor, and in 1572 Maximilian caused his eldest son Rudolph to be crowned king of Hungary. He was afterwards crowned king of Bohemia, and was also elected king of the Romans. Maximilian died in 1576, and was succeeded by Rudolph on the imperial throne. This monarch was little fitted to rule, and left the management of affairs very much to others. He was entirely under the power of the Jesuits, set at nought the ancient laws of the country, and persecuted the Protestants. The latter, under Bocskay, revolted in 1604, and having secured the aid of the sultan, gained repeated victories over the imperial troops, compelling Rudolph to give them terms of peace in 1606. During this reign the possessions of the Archduke Ferdinand of Tyrol reverted to the two other lines; while in 1608 Rudolph was compelled to cede Hungary, and in 1611 Bohemia and Austria, to his brother Matthias, who on the death of Rudolph in 1612 was crowned emperor. His reign was full of promise, but unfortunately it was only of short duration. Being an old man and childless, he chose as his successor his cousin Ferdinand, archduke of Styria, whom he caused to be crowned king of Bohemia in 1616, and of Hungary in 1618. He died the following year, when Ferdinand became emperor.

Before the death of Matthias, the memorable struggle between Roman Catholicism and Protestantism, known as the *Thirty Years' War* (1618 to 1648), had commenced. It originated in an insurrection of the Protestants of Bohemia, who renounced their allegiance to Ferdinand and chose for their king the elector palatine Frederick V. Frederick was supported by all the Protestant princes except the elector of Saxony, while Ferdinand was assisted by the king of Spain and the other Catholic princes. At first success attended the arms of the insurgents, who repeatedly routed the imperial troops, and even laid siege to Vienna. But the Duke Maximilian of Bavaria, coming to the assistance of the imperialists at the head of a well-appointed army, totally defeated Frederick at the White Hill near Prague (8th November 1620). The following day Prague opened its gates to the conqueror, and in a short time the whole country was reduced to subjection, and the territories of the elector palatine divided among the allies. The war might have ended here had Ferdinand adopted a conciliatory policy, but impelled by revenge and fanatical zeal he adopted an opposite course, and instituted against the Protestants a severe persecution. They were thus again compelled to take up arms, and in 1625 Christian IV., king of Denmark, supported by subsidies from England, put himself at their head. He was subsequently joined by Count Mansfeld and Christian of Brunswick, while opposed to him were Wallenstein and Tilly at the head of two powerful armies. In April 1626 Mansfeld was defeated by Wallenstein at Dessau, and a few months later Tilly vanquished the Danish king at Lutter. The victorious armies afterwards marched into Denmark, and the king was compelled to conclude a humiliating peace at Lübeck in 1629. The Protestants were now awed into submission, and Ferdinand was emboldened to carry out to still greater lengths his policy of suppression. Aiming at the total extirpation of Protestant doctrines throughout his dominions, he revoked all the privileges that had formerly been granted, even such as had previously received his approval. By the so-called *Edict of Restitution*, dated 6th March 1629, he enjoined the restitution of all ecclesiastical property secularised since the peace of Passau, and ordered the Protestants to relinquish to the Catholics all benefices which they had appropriated contrary to the peace of Passau and the Ecclesiastical Reservation.

The Catholic princes themselves were now becoming alarmed at the enormous power which they had contributed to place in the hands of the emperor. They therefore

demanding a reduction of the army and the dismissal of Wallenstein, and with these demands the emperor felt himself obliged to comply. But a new champion of the Protestant cause now appeared in the north, in the person of Gustavus Adolphus, king of Sweden. This valiant prince, having received promises of aid from France as well as from England and the United Provinces, suddenly landed an army of 15,000 men at Usedom in June 1630. Pomerania and Mecklenburg were soon conquered by him, and a great part of Brandenburg was overrun by his army. He was unable, however, to relieve the town of Magdeburg, which was besieged by Tilly and taken by assault 20th May 1631, when the most barbarous atrocities were perpetrated upon the unfortunate inhabitants. The elector of Brandenburg and afterwards the elector of Saxony joined Gustavus, and the combined army met the imperialists under Tilly at Breitenfeld, near Leipsic, and defeated them with great slaughter (7th September 1631). The victor now rapidly regained all that had been lost. Again Tilly was beaten at the passage of the River Lech on 5th April 1632, and the following day he died of his wounds. Wallenstein was now recalled and placed at the head of the imperial troops. His name inspired fresh ardour among the soldiery, men flocked to his standard, and he speedily found himself at the head of a very large army. He drove the Saxons out of Bohemia, and afterwards marched to Nuremberg, where Gustavus was entrenched in a strong position. The two armies watched each other for eight weeks, when the king directed an attack against the imperialists, but after a fierce struggle was repulsed. A fortnight later Gustavus moved in the direction of Bavaria, but Wallenstein, instead of following him, marched into Saxony, and thus obliged him to suspend his operations in Bavaria and to set out in pursuit of his opponent. The two armies met at Lützen, where a battle took place on 16th November 1632. The greatest skill and bravery were displayed on both sides, and the issue was long doubtful, but at length victory declared in favour of the Swedes, though dearly purchased with the loss of their brave commander, who fell mortally wounded.

The death of Gustavus was an irreparable loss to the Protestants in Germany. Wallenstein, however, made but little use of the advantages he now possessed, and has even been accused of treacherous designs against the empire. Be this as it may, his enemies at court and in the army were numerous and powerful, and he was at length assassinated by some of his own officers, 25th February 1634. The Protestant cause met with another disaster in the defeat of Bernard of Weimar at Nordlingen on 6th September. On 30th May 1635 Saxony concluded at Prague a treaty of peace with the emperor, in terms of which the Lutherans were freed from the operation of the Edict of Restitution. The other Lutheran princes soon after accepted the like terms; but the Calvinists, who were disliked by both parties, were left to their fate.

Sweden, no longer able to carry on the war as she had done, entered into a treaty with France, resigning the direction of operations to that power, a position of which Richelieu gladly availed himself, as according with his ambitious designs. The war now assumed a new phase, France and Sweden being allied against the empire and the Lutheran states of Germany, aided by Spain. Richelieu's efforts were in great measure directed to humbling the latter power. He sent an army into Spain, and entered into leagues with the dukes of Savoy and Parma and the United Provinces for attacking the Spanish power in Italy and the Netherlands. These projects did not meet with success, and the war was for a time carried into the French territories. In the meantime the Swedes, under General Banér, gained a brilliant victory over the Saxons and imperialists at Wittstock (4th October 1636). The emperor

died on the 15th February 1637, and was succeeded by his son Ferdinand III. The war was carried on for eleven years longer; and the success which at first was with the imperialists, after a time came round to their adversaries, till at length the emperor, pressed on all sides and deserted by his allies, was glad to agree to terms of peace. By the peace of Westphalia, signed 24th October 1648, France acquired Alsace; Sweden got Upper Pomerania, the Isle of Rugen, and some other territory; the sovereignty and independence of the different states was recognised; the Calvinists were placed on the same footing as the Lutherans; and the independence of the United Provinces and the Swiss Confederation was acknowledged.

Ferdinand III died in 1657, and was succeeded by his son Leopold I. This prince, by his harsh treatment of the Hungarians, drove that people into revolt; and they, being unable to cope with the power of the empire single-handed, called in the aid of the Turks, who, under Kara Mustapha in 1683, besieged Vienna, which was only saved by an army of Poles and Germans under John Sobieski. The imperial army then reduced the whole of Hungary into subjection, and united to it Transylvania, which had been hitherto governed by its own princes; and the whole was declared to be a hereditary kingdom. In 1699 Turkey, after being defeated in several sanguinary engagements by the celebrated general Prince Eugene, was compelled by the peace of Carlowitz to cede to Hungary the country lying between the Danube and the Theiss. Previous to his troubles with Hungary and Turkey, Leopold had lent his aid in 1672 to the Dutch in their struggle against the ambitious designs of France. This was brought to a close by the peace of Nimeguen in 1678; but the conflict broke out afresh the following year, when the English also came forward and contributed largely both in troops and money. The chief scenes of warfare were the Netherlands and the banks of the Rhine. At last in 1697 came the peace of Ryswick, which left the contending parties in nearly the same relative positions as at the beginning of the contest. The allies had, however, the satisfaction of having compelled the French king to stop short in his schemes of aggrandisement.

The death of Charles II. of Spain in 1700, without leaving issue, led to what is known as the *War of the Succession*. Louis XIV. had married the eldest sister of the late king, but she had by solemn covenant renounced her right to the Spanish crown. The second sister had married the Emperor Leopold, and she had made no such renunciation, but her daughter had, who was married to the elector of Bavaria. Leopold had two sons by a second marriage, and now claimed the crown for the younger of these, on the ground of his mother being an aunt of the deceased king. Intrigues had been carried on by the several parties concerned for some time before the king's death, and he had been induced to make a secret will, in which he named Philip, duke of Anjou, grandson of Louis XIV., as his successor. Leopold, however, was by no means inclined to depart from what he considered his rights, and the other states of Europe looked with jealousy on the prospect of a union of France and Spain under a Bourbon dynasty. An alliance was accordingly formed by Austria with England and Holland against France, with which power on the other hand Bavaria allied herself. The emperor despatched an army into Italy under Prince Eugene, to take possession of the Spanish territories in that country; while the English and Dutch united their forces under Marlborough. The former experienced a good deal of hard fighting, but effected little of consequence, while the latter busied himself in taking one after another of the French strongholds in the Netherlands. At length the two generals combined their forces

and met the united army of their enemies at Blenheim. The latter numbered about 56,000 men and occupied a strong position, while the number of the former was about 52,000. The fight commenced by Marlborough leading the right wing against the French, while Eugene with the left wing advanced against the Bavarians. The battle was long and fierce, the assailants being repeatedly driven back by a most terrible fire from the enemy's artillery. At length victory declared for the allied English and Austrian armies (13th August 1704). About 10,000 of the French and Bavarians fell on the field, and nearly 13,000 were made prisoners, among whom was the commander of the French army, Marshal Tallard. The elector of Bavaria was compelled to cross the Rhine with the French, and his territory was occupied by the imperialists. The following year the emperor died, and was succeeded by his eldest son, Joseph. The war was continued with vigour, but for a time nothing of importance was anywhere effected. France now directed her chief attention to the conquest of the Netherlands, and sent into that country a magnificent army under the command of Marshal Villeroi. But this general was no match for Marlborough; and in the battle of Ramillies (23d May 1706) he was totally defeated with a loss of about 13,000 men. Prince Eugene's efforts in Italy were also this year crowned with much success. After a memorable march of more than 200 miles, he suddenly appeared before Turin, which was then closely besieged by the enemy. Having effected a junction with the duke of Savoy, he attacked the French lines (7th September), and though repeatedly driven back, at length succeeded in totally routing the enemy. The French general, Count Marsin, was wounded, taken prisoner, and died the following day. The French power in Northern Italy was thus shattered, and soon after both French and Spaniards were driven out of the country. The like success attended the efforts of Marlborough in the Netherlands, where he took possession of every place of note. After Eugene had settled affairs in Italy, he again formed a junction with Marlborough in the Netherlands, and on 11th June 1708 they attacked and routed the French under Vendôme at Oudenarde. France now made overtures for peace; but these being rejected, she sent a new army into the field, under the command of Marshal Villars. He was attacked by the two victorious generals in his entrenchments at Malplaquet (11th September 1709) and totally defeated. France again made proposals for peace, but these meeting with no better success, the war was continued. The emperor died on 17th April 1711, and his successor being his brother, the Archduke Charles, who laid claim to the Spanish crown, this event contributed not a little to restore peace. The prospect of the union on one head of the crowns of Austria and Spain did not accord with the views of those who had been hitherto supporting the claims of Austria, and the transfer of Spain to a grandson of Louis XIV. appeared to them the less dangerous alternative of the two. This, joined to the change of ministry in England, and the removal of Marlborough from the command, together with the impatience of the Dutch under so long and so burdensome a war, led to the peace of Utrecht, which was signed 11th April 1713. Austria continued the war for some time longer, but the next year agreed to substantially the same terms at Baden. By this treaty France engaged that the crowns of France and Spain should never be united, and that no part of the Spanish Netherlands should ever be transferred to her; she also ceded to England Nova Scotia, Newfoundland, Hudson's Bay, and St Kitt's, and agreed to destroy the fortifications of Dunkirk; Spain gave up her possessions in the Netherlands and in Italy to Austria (who, on her part, renounced her claim to the Spanish

succession), and ceded Gibraltar and Minorca to England; the Dutch received a small accession of territory; and the duke of Savoy obtained Sicily, with the title of king—afterwards (1720) exchanged for the island of Sardinia. The Austrian monarchy now embraced about 190,000 square miles of territory, with nearly 29,000,000 of inhabitants. Its annual revenue was between 13,000,000 and 14,000,000 florins, and its army consisted of 130,000 men.

Austria next became involved in a war with the Turks, and in 1716 Prince Eugene set out at the head of an army against them. The result was a series of splendid successes, which led to a peace signed at Passarowitz (1718), by which Austria received a considerable accession of territory. Disaffection still continued to subsist between Spain and Austria, which led to repeated negotiations on the part of the other powers to preserve peace. Charles being without heirs-male, was desirous of securing the succession to his eldest daughter, Maria Theresa, and with this view he framed the celebrated Pragmatic Sanction, and it became his great object to get the assent of the other powers to this arrangement. England and almost all the other powers, except France, Spain, and Sardinia, acceded to it in 1731. In 1733 the emperor became involved in a war with France on behalf of Augustus III. of Saxony, who had been elected king of Poland. France supported the claims of Stanislaus Leczinski, and received the aid of Spain and Sardinia. The war was carried on principally in Italy, where Austria was driven out of most of her possessions, and was glad to sue for peace. By this treaty Augustus was confirmed on the throne of Poland; but Austria was obliged to cede to Stanislaus the duchies of Lorraine and Bar, to be afterwards transferred to France; Don Carlos was placed on the throne of the Two Sicilies, and the grand duchy of Tuscany was bestowed on the duke of Lorraine, the emperor receiving as compensation Parma and Placentia; and France, and afterwards Spain and Sardinia, acceded to the Pragmatic Sanction. War again broke out with the Turks, and Prince Eugene being now no more, the Austrians were repeatedly beaten and expelled from one stronghold after another, till, by the peace of Belgrade (1739), the emperor was compelled to yield up almost all that the arms of Eugene had formerly gained for him. The emperor died on the 20th October 1740, and his eldest daughter, Maria Theresa, who was married to the duke of Lorraine or Lothringen (afterwards archduke of Tuscany), assumed the government. Immediately counter-claims were advanced on all sides. The elector of Bavaria claimed to be rightful heir to the kingdom of Bohemia; the elector of Saxony and king of Poland, and also the king of Spain, claimed the entire succession; the king of Sardinia laid claim to the duchy of Milan, and Frederick II. of Prussia to the province of Silesia. France espoused the cause of Bavaria, while England alone came forward to the assistance of the queen, and the Hungarians, now united and loyal, willingly recruited her armies. Aided by France and Saxony, the elector of Bavaria took possession of Bohemia, and was proclaimed king in 1741, and the following year he was elected emperor under the title of Charles VII. The king of Prussia marched suddenly into Silesia and took possession of that country. The elector of Bavaria, aided by French troops, next invaded Austria, and even threatened Vienna. The queen fled to Presburg and convoked the Hungarian diet. She appeared in the midst of the assembly with her infant son Joseph in her arms, and appealed to them for protection and help. A burst of enthusiasm followed, and a powerful Hungarian army was speedily at her service. The French and Bavarians were soon driven out of the archduchy. A

battle was fought between the Austrians under the prince of Lorraine and the Prussians under Frederick, at Czaslau (17th May 1742), in which the former were defeated, and this was followed by the peace of Breslau (11th June), by which Prussia acquired possession of Upper and Lower Silesia (excepting the towns of Troppau and Jägerndorf, and the mountains of Silesia) and the county of Glatz. Austria now turned her arms against the French and Bavarians, the former of whom were driven out of the country. In 1744 the king of Prussia, jealous of the success attending the Austrians, again took the field against them in support of the emperor. He marched into Bohemia and took Prague, but subsequently was forced to retreat; and the death of the emperor Charles on 20th January 1745 changed the aspect of affairs. Maria Theresa's husband was in September elected emperor under the title of Francis I., and after some more fighting, a peace was concluded with Prussia at Dresden, by which the king was confirmed in the possession of Silesia. The war with France was prosecuted for some time longer in the Netherlands and in Italy with varying success, but ultimately peace was concluded at Aix-la-Chapelle, in October 1748. Austria gave up the duchies of Parma, Placentia, and Guastalla to Don Philip, son of the king of Spain, and several districts of Milan to Sardinia; Prussia was confirmed in the possession of Silesia and Glatz; while Maria Theresa was recognised as rightful monarch of Austria. After having acquired peace, and been thus confirmed in her possessions, her great desire was to recover Silesia from Frederick, whose conduct towards her had sunk deep into her heart. She directed her attention to strengthening, and improving her army, and to forming alliances with the other states against the Prussian king, particularly with Russia and Saxony. In 1755 war broke out in North America between France and England, and in view of its becoming more general England solicited the aid of Austria, but without success. This naturally led to a union between England and Prussia, while France allied herself with Austria and Russia.

In July 1756, Frederick despatched a messenger to Vienna to ascertain the meaning of the large forces assembled in Bohemia and Moravia. Receiving an evasive answer, he at once marched an army of 60,000 men into Saxony, took Dresden, and made himself master of the country, the Saxon army of only about 17,000 men being shut up in a strong position, but ill provisioned, between Pirna and Königstein. An Austrian army, under the command of Marshal Browne, advanced from Bohemia to the relief of Saxony, but was met by Frederick. A battle took place at Lowositz (1st October), which, though not decisive, ended in the retreat of the Austrians; and the famished Saxon army, after an ineffectual attempt to effect a retreat to Bohemia, laid down their arms. This ended the first campaign, and both sides did their utmost to prepare for renewing hostilities the following year. The empress strengthened her forces in Bohemia, and the imperial diet conceded an army of 60,000 men to assist her. France engaged to send an army of 80,000 or 100,000 men into Germany, and Russia set in motion an army of 100,000 men against Prussia. In all, the allies were estimated to muster about 500,000 men, while Frederick could scarcely raise 200,000 of his own, his auxiliaries (English, Hanoverians, &c.) probably amounting to about 40,000 more. Frederick renewed the war by marching an army into Bohemia, where, on 6th May, he gained a victory over the Austrians, under Prince Charles of Lorraine, in the neighbourhood of Prague, and then laid siege to that city. General Daun, at the head of an Austrian army, advanced to the relief of the city, and the king set out to meet him. The encounter took place at Kolin (18th June), and the

Prussians, being much inferior in numbers, were beaten with great slaughter. Frederick was compelled at once to raise the siege and to evacuate Bohemia. In honour of this victory the empress instituted the military order of Maria Theresa. It had also the effect of inspiring the allies with fresh courage. The Russians invaded the kingdom of Prussia; the Swedes entered Pomerania; and two French armies crossed the Rhine in order to attack Hesse and Hanover and then march into Prussia. One of these armies, under the command of Prince Soubise, advanced towards Thuringia, in order to form a junction with the imperial forces under the prince of Hildburghausen, while Marshal d'Estrees, who commanded the larger French army, entered Hanover, and through the incapacity of his opponent, gained an easy victory over the Anglo-Germanic army, under the duke of Cumberland, near Hastenbeck, on the Weser (26th July). The duke afterwards completed his disgrace by agreeing to disband his troops and give up Hanover, Hesse, Brunswick, and the whole country between the Weser and the Rhine, to the French. The other French army effected a union with the imperial troops of Thuringia, and made preparations for driving the Prussians out of Saxony. Frederick, however, determined to meet them, and after a series of marches and countermarches the two armies came together near Rossbach. The Prussian army amounted to about 22,000 men, while that of the French and Austrians numbered nearly 60,000. Frederick's troops were encamped upon a height, and the allies, when they advanced to the attack, were suddenly met by such a tremendous fire that they were thrown into confusion and unable to recover themselves. In less than half an hour the day was decided (6th November 1757). The allies had 1200 killed and more than 7000 taken prisoners, while the loss of the Prussians scarcely exceeded 500 in killed and wounded: At this time the imperialists had entered Silesia and there gained several advantages over the Prussians, who were at length driven to the walls of Breslau. Here a battle was fought (22d November) in which the Austrians were victorious, and the city itself soon after surrendered to the conquerors. Frederick now made what haste he could to retrieve his fortunes in this quarter, and met the Austrian army, under Prince Charles of Lorraine, in a plain near the village of Leuthen. The Austrians numbered about 80,000 men, while the Prussians did not exceed 30,000, yet by the skilful disposal of his troops and the celerity of his movements Frederick again gained a complete victory (5th December). The field was covered with slain, and it is estimated that about 20,000 surrendered themselves prisoners. Breslau was speedily retaken, and the Austrians driven out of Silesia.

The English were very indignant at the treaty entered into by the duke of Cumberland, and another army was speedily raised and placed under the command of Duke Ferdinand of Brunswick, who commenced the campaign of 1758 by suddenly attacking the French in their winter quarters. In a few weeks he succeeded in driving them out of the country, pursued them across the Rhine, and attacked them furiously at Crefeld, where they were completely routed.

While Field-Marshal Daun, who had received the command of the Austrian army, was waiting the attack of Frederick in Bohemia, the latter, by forced marches, entered Moravia and laid siege to Olmütz. The town, however, defended itself with the greatest bravery, and the Prussians were compelled to raise the siege. By this time, Daun having blocked up Frederick's retreat into Silesia, the Prussian army was marched suddenly northward into Bohemia, and attacked the Russians who had invaded Brandenburg. After a desperate battle the latter were defeated with great slaughter at Zorndorf (26th

August), and compelled to retreat into Poland. Frederick now entered Saxony, where his brother Prince Henry was hard pressed by the Austrians. Thereupon Daun retired to a strong position in Lusatia, and Frederick took up a position near him, little thinking that Daun would attack him. Early in the morning of the 14th of October, however, the Austrians suddenly fell upon him at the village of Hochkirchen, and in the confusion and darkness the slaughter was terrible. Frederick lost several of his best generals, including Prince Francis of Brunswick, Prince Maurice of Dessau, and Field-Marshal Keith, with about 9000 of his soldiers. His camp, baggage, and ammunition also fell into the hands of the Austrians. The victory, however, was productive of little material results; Frederick retreated into Silesia, while the Austrians, after ineffectual attempts on Leipsic, Torgau, and Dresden, retired to Bohemia for the winter. The Austrian army was again largely reinforced, and every preparation made for renewing hostilities with vigour. The following year (1759) Duke Ferdinand found himself hard pressed by two French armies under the Duke de Broglie and the Marshal de Contades. He sustained a defeat at Bergen (12th April), but afterwards gained a signal victory at Minden (1st August), and compelled the French to retreat. Daun, waiting the approach of the Russians, did not take the field till the beginning of May, when, on their advance towards the Oder, he moved into Lusatia. In June, Dohna, who was sent to check the advance of the Russians, was forced to retreat, and, on the 23d July, Wedel, who succeeded him in the command, was totally routed near Züllichau. The Russians then marched on to Frankfort-on-the-Oder, where they were joined by 18,000 Austrians under Marshal Loudon. Frederick hastened with what troops he could collect to give battle to the combined army. The latter took up a strong position on the heights near Kunersdorf, and there they were attacked early on the 12th of August by the king. The Prussians numbered about 50,000, while the Russians and Austrians amounted to 90,000. The battle raged long and furiously, and the issue was long doubtful, but at length the Russians were giving way on all sides, and victory was about to declare for the Prussians, when unexpectedly the Austrians made a furious attack upon them, threw them into confusion, and in a short time drove them from the field. Frederick lost in this action 20,000 of his bravest troops, and the loss on the side of the allies was not less than 24,000 men killed and wounded. In the meantime the Austrians overran Saxony, took Torgau, Wittenberg, and Leipsic, and invested Dresden, which, after a spirited defence, surrendered when an army of relief was close at hand. But Frederick was speedily in the field again at the head of a new army, and, by dint of skilful manœuvring and cutting off supplies, he succeeded in harassing the two armies, and compelled the Russians again to retire into Poland. An army of 13,000 men, under General Fink, attacked the rear of the Austrian army near Maxen, but after a brief but sanguinary conflict they were defeated and taken prisoners. Daun took up his winter quarters in Saxony, notwithstanding every effort of Frederick to dispossess him.

The imperial troops had been very successful during the last campaign, and were in good condition to renew the fight, while the Prussians had sustained great losses, were dispirited, and could only muster about 80,000 fighting men, and these no longer veterans, but in great measure raw recruits. In the campaign of 1760 Frederick was himself to conduct the war in Saxony, Prince Henry was to protect the marches against the Russians, and General Fouquet was to defend Silesia against the Austrians under Loudon. On 23d June, 8000 Prussians, under Fouquet, were surrounded and attacked on all sides by 30,000 Austrians at Landshut,

and, after defending themselves long with great bravery, were obliged to yield. The king, after an ineffectual attack upon Dresden, marched into Silesia followed by the Austrians. At Liegnitz he found himself between three armies, under Generals Daun, Lacy, and Loudon, numbering about 90,000 men, while his own army amounted to only about 30,000. On the night preceding the 15th of August, Frederick took up a position on the neighbouring heights of Pfaffendorf. Scarcely had he done so when the Austrian army, under Loudon, made its appearance, it having also intended to occupy the same position, and then fall upon the Prussians. The Austrians were greatly astonished to find the enemy before them; nevertheless, they fought for three hours with great bravery, returning again and again to the attack, but were at length compelled to retreat with a loss of 4000 killed and 6000 wounded. Daun afterwards came up and made an attack upon the Prussians, but, learning what had happened to Loudon, he withdrew. Frederick now directed his march on Breslau; and meanwhile the Russians effected a junction with the Austrians, and marched on Berlin, which surrendered to them (3d October). A week later, hearing that the king was advancing against them, they left the city and retired into Saxony. Daun had likewise arrived in Saxony, and taken up a very strong position near Torgau. Here the Prussians attacked him with great fury on 3d November. The battle lasted till night without being decisive, and the carnage on both sides was fearful. The Prussians prepared to renew the attack next day, but the Austrians retreated during the night. They lost about 12,000 men killed and wounded, and 8000 prisoners. By this battle Frederick reconquered the greater part of Saxony, and accordingly he fixed his winter quarters there, establishing his headquarters at Leipsic. In 1761 Frederick employed every stratagem to prevent the junction of the Russian army under Buturlin with the Austrian under Loudon. The two armies, however, at length came together in the environs of Strigan (12th August), the combined force amounting to 130,000 men, while the Prussians numbered only about 50,000. The leaders, however, could not agree to a common course of proceeding, and the two armies separated without effecting anything of consequence. The Austrians surprised and took Schweidnitz (1st October), and the Prussians, after a four months' siege, took possession of Colberg (13th December). In Saxony Prince Henry had to retreat before Daun; but the latter gained no great advantages, and Frederick settled in Breslau for the winter. It seemed as if Prussia must at last yield to her assailants, but this was as far as ever from the king's mind. To add to his difficulties, the subsidies from England were stopped by the earl of Bute after the death of George II. But by the death of the Czarina Elizabeth (5th January 1762) he was freed from one of the most powerful of his enemies; and her successor, Peter III., not only recalled the army, but delivered up all the Prussian prisoners, and even entered into an alliance with the king. Sweden also retired from the contest, and entered into terms of peace. Frederick was therefore in a better condition to carry on the war vigorously against Austria, and the seventh campaign was marked by a series of disasters to that power. He attacked and overthrew Daun's right wing at Burkersdorf (21st July), gained a victory at Beichenbach (15th August), and took Schweidnitz after a very gallant defence (9th October). Prince Henry was also victorious at Freiberg (29th October). In the meantime Duke Ferdinand had been during the last three years successfully maintaining the war with the French. Fresh reinforcements and new generals were brought against him, but he could not be crushed; and, by the victories of Wilhelmsthal (24th June) and Luttern-

burg (23d July), France was brought to agree to peace. Thus Austria and Prussia were left to carry on the war alone; and the former, though amply provided with troops, was without money to furnish the necessary supplies, while Frederick was ever ready to come to terms on having the possession of Silesia secured to him. Austria found herself obliged to yield this point, and peace was at length agreed to. The treaty was signed at the castle of Hubertsburg, in Saxony, 15th February 1763, and thus ended the Seven Years' War,—a war disastrous to all concerned, and which is estimated to have cost in actual fighting men 853,000. It effected no territorial change in any of the countries, but through it Prussia rose to be one of the great powers of Europe. Austria, on her part, had carried on the conflict with remarkable vigour and determination; her soldiers had displayed great bravery, and some of her generals had shown a military genius not greatly inferior to that of Frederick himself.

Maria Theresa now zealously devoted herself to improving the condition of her people and country. She established schools, removed feudal hardships, improved the condition of the serfs, reformed ecclesiastical abuses, and fostered industry and commerce. The Emperor Francis died 18th August 1765, and was succeeded by his son, Joseph II., who the previous year had been elected king of the Romans. He also became joint-regent with his mother of the hereditary states. Maria established two collateral branches of her house in the persons of her two younger sons, the Archduke Leopold in Tuscany, and the Archduke Ferdinand, who married the heiress of Este, in Modena. By the first partition of Poland (1772) Austria acquired Galicia and Lodomeria, and in 1777 Buckovina was ceded by the Porta. On the death of the elector of Bavaria without issue, the Emperor Joseph laid claim to his dominions. To this Frederick was opposed, and again took the field against Austria. The dispute, however, was settled without war (1779), Austria being content with the cession by Bavaria of the frontier district called the quarter of the Inn, and one or two others. The empress died 29th November 1780, in the sixty-fourth year of her age and the forty-first of her reign. She was a woman of many and great virtues, with few weaknesses, and effected more for Austria than any of her predecessors. Mr Carlyle says that she was "most brave, high and pious minded; beautiful, too, and radiant with good nature, though of a temper that will easily catch fire; there is, perhaps, no nobler woman then living." At her death the monarchy comprised 234,500 square miles, with a population estimated at 24,000,000, and a public debt of 160,000,000 florins, or £16,000,000.

The Emperor Joseph II., whose zeal for reform had in great measure been kept in check during the lifetime of his mother, now felt himself at liberty to give it full scope. He attempted a number of changes, of which several were praiseworthy in their objects, but abrupt and premature in their operation, so that in the end they were productive of evil consequences. He sought to establish a system of central government and uniformity of legislation throughout his dominions; enjoined the exclusive use of the German language in all schools, courts of justice, &c.; granted free and unreserved toleration to all sects of Christians; abolished numerous convents and monasteries; dismantled various fortresses; and did away with primogeniture and feudal vassalage. Had his people been ripe for these changes he would probably have been hailed as a reformer of abuses; but the Austrians were attached to their old usages, and were little inclined for change, while the arbitrary manner in which the improvements were introduced could not fail to provoke discontent. General uneasiness, therefore, began to prevail, which in the Netherlands

broke out into open revolt in 1789. This, together with an unsuccessful war in which he had engaged with Russia against Turkey, is understood to have preyed upon his over-sensitive mind, and caused his death on 20th February 1790. He was, says Mr Carlyle, "a man of very high qualities, and much too conscious of them; a man of ambition without bounds; one of those fatal men—fatal to themselves first of all—who mistake half genius for whole; and rush on the second step without having made the first."

He was succeeded by his brother Leopold, grand duke of Tuscany, who by his moderation and firmness was successful in restoring peace to the country, and in quelling the insurrection in the Netherlands. He also made peace with the Porte. The misfortunes of his sister Maria Antoinette and her husband, Louis XVI. of France, led him to enter into an alliance with Prussia against the Revolutionists, but he died before the war broke out (1st March 1792). He was succeeded by his son, Francis II., who had hardly ascended the throne when he found himself involved in a war with France. Hostilities commenced on 28th April with an attempted invasion of Flanders by the French, but their undisciplined troops were speedily routed and put to flight. A combined army of 50,000 Prussians, under the command of the duke of Brunswick, and 15,000 Austrians under General Clairfait, besides about 20,000 French, soon after crossed the French frontier, took Longwy and Verdun, and marched on Paris. In the meantime Dumouriez was actively engaged in collecting an army, and soon found himself in a condition to meet them. A series of engagements took place without any decided result, beyond checking the advance of the allied troops, who were now also suffering very severely from sickness and famine. It was therefore deemed prudent to retire, and Verdun and Longwy were soon after retaken. Dumouriez next invaded the Netherlands with an army of 100,000 men, to oppose which the Austrian army only amounted to 40,000. A battle took place at Jemappes on the 6th of November, in which the Austrians fought with heroic bravery, and the contest was long doubtful, but the superior numbers of the French carried the day. The loss on both sides was very great; and soon after the whole of the Austrian Netherlands, with the exception of Luxemburg, was in the hands of the French. The commencement of the campaign of 1793 was distinguished by a series of brilliant victories gained by the allies in the Netherlands. Dumouriez was defeated at Aldenhoven, and again in a great battle at Neerwinden (18th March). Soon after, afraid of falling into the hands of the Jacobins in Paris, he passed over to the allies. His successor, General Dampierre, was defeated and slain on the plains of Famars, and the allies became masters of Valenciennes and Condé. Towards the end of the campaign, however, the republican troops were successful in a number of engagements. At the commencement of the year 1794, the Austrians, Dutch, English, and Hanoverians united their forces in the Netherlands under the command of the prince of Coburg, and the Emperor Francis himself joined the camp, in order by his presence to encourage the troops. In April the allies were successful at Cateau and at Landrecies, and took that town; but their good fortune then forsook them. Clairfait was attacked singly at Kortryk by Pichegru, and forced to yield to superior numbers; and the allies under the prince of Coburg were attacked by him at Tournay (22d May), when an extremely long and bloody, but undecided, battle was fought. The Austrian troops were now greatly dispirited; and, on the 26th June they were defeated by General Jourdan at Fleurus. This was followed by other disasters, so that all Flanders was soon in the hands of the French. Pichegru, pursuing his victorious career, next invaded Holland, which, before the end

of the year, was transformed into a republic. In the beginning of 1795 Prussia abandoned the cause of the allies, and concluded a treaty of peace with the French republic at Basle (5th April), and was joined therein by Hanover and Hesse Cassel, so that Austria and England were left alone to prosecute the war. For some months a cessation of hostilities took place between the contending parties; but on the 6th of September the French army under Jourdan suddenly crossed the Rhine near Düsseldorf, invested that town, and drove the Austrians before it over the Maina. Clairfait, however, reassembled his troops behind the latter river, and attacked the French at Höchst, near Frankfort, and completely defeated them (11th October), so that they were obliged to recross the Rhine. In the meantime Pichegru had crossed the river with another army, near Mannheim, and took possession of that town. Wurmser, who was sent for its relief, arrived too late for that purpose, but attacked the French army near it, put them to flight, and compelled them to recross the Rhine, leaving a garrison of 8000 men to defend the town, which, after a vigorous siege, surrendered to the Austrians. The French, undismayed by these failures, were only stimulated to greater efforts; and the following year they sent out three armies against Austria, one under Jourdan towards the Lower Rhine, another under Moreau towards the Upper Rhine, and a third into Italy. In the end of May the French army under Jourdan crossed the Lower Rhine, and gained some successes, but was afterwards attacked by the Archduke Charles (16th June), and forced to recross the river. Moreau soon after effected his passage over the Upper Rhine at Strasburg, defeated the Austrians in several partial engagements, and reduced the circle of Swabia to subjection. Jourdan again pushed forward his troops, and took Frankfort by bombardment, but was defeated with great loss by the archduke at Amberg (24th August), and again at Würzburg (3d September). Moreau had in the meantime continued his advance into Bavaria, but was ultimately obliged to effect a retreat, which he carried out with great skill, suffering comparatively little loss, and recrossing the Rhine on 20th October. But a different fate was attending the army in Italy, under the command of a young officer, who afterwards became world-famous for his generalship, namely, Bonaparte. By the promptitude of his movements, and the suddenness of his attacks, he completely overcame and separated the army of the Sardinians from that of the Austrians, and forced the Sardinian king to sign a treaty of peace. He then turned his arms against the Austrians, defeated them in several engagements, and made himself master of the whole of Lombardy, except Mantua. Wurmser was now summoned from Germany with an army of 30,000 men, which raised the Austrian force to about 60,000; while opposed to them were about 55,000 French. Instead, however, of advancing in one body, the Austrians were divided into two columns, which advanced by different routes, a mistake of which Bonaparte did not fail to take advantage. One division of 20,000 men was attacked and compelled to retreat towards the mountains, while Wurmser with the other division entered Mantua. Learning that city he sustained a double defeat at Lonato and Castiglione (3d August); and, being again severely beaten at Medola (5th August), he was forced to seek shelter in the mountains of Tyrol. Having received reinforcements, however, he again advanced in divided columns, one of which was defeated at Roveredo, the other, under himself, near Bassano. He took the road to Mantua with the remains of his army, and reached that town after a brilliant victory over a body of French troops that had been sent to intercept him. Meanwhile the Austrians collected another army of 40,000 men under Alvinzi, who, after a series of successes, gained a decided victory over Bonaparte at

Caldiero (11th November). Four days later the Austrians were again attacked by the French near the village of Arcola, and after three days' desperate fighting on both sides the Austrians at length retreated. Alvinzi received reinforcements, and again set out to attack the French, but suffered a severe defeat at Rivoli on 14th January 1797. A fortnight later Mantua capitulated, and the French became undisputed masters of the country. Speaking of the perseverance and patriotic spirit of the Austrians in this struggle in Italy, Sir A. Alison says, "It is impossible to contemplate without admiration the vast armies which they successively sent into the field, and the unconquerable courage with which these returned to a contest where so many thousands of their countrymen had perished before them. Had they been guided by greater or opposed by less ability they unquestionably would have been successful, and even against the soldiers of the army of Italy and the genius of Napoleon, the scales of fortune repeatedly hung equal."—(*History of Europe*.) The Archduke Charles was now recalled from the Rhine to oppose Bonaparte. The latter set out on his journey northward on the 10th of March, with the view of crossing the Alps and so reaching Vienna. The Austrians attempted to oppose his progress at the river Tagliamento, but without success; and a desperate struggle took place for the possession of the Col de Tarnis, which ended in favour of Napoleon, so that in twenty days after the campaign opened the army of the archduke was driven over the Julian Alps, and the victorious French army of 45,000 strong was on the northern declivity of the Alps, within 60 leagues of Vienna. Napoleon, still pressing on, took possession of Klagenfurt, and advanced as far as Judenburg on the River Mur; but finding his position very insecure, and dangers thickening upon him, he despaired of carrying out his intention of dictating peace under the walls of Vienna. He therefore offered terms of accommodation to the Austrians, which they deemed it prudent to accept. Preliminaries were agreed to at Leoben (18th April), and a formal treaty of peace was signed at Campo Formio, 17th October 1797. By this treaty Austria ceded to France Flanders and her Italian possessions, and received in return Venice and its dependent provinces. It, however, contained certain secret articles, by one of which Austria consented to surrender the whole of the left bank of the Rhine to France; and a convention was appointed to meet at Rastadt to provide equivalents on the right bank for the princes dispossessed on the left, and otherwise to settle the affairs of the empire. The terms were not particularly hard as regards Austria. The ceded territories contained about 3,500,000 souls, and those acquired about 3,400,000. But the taking away of the independence of Venice, which had been maintained for 1400 years, was an act of rapacity which excited the indignation of Europe, and Austria's share in it must ever remain a stain on her annals.

This peace was not of long duration. As the business of a convention which met at Rastadt advanced, and the bearing of the secret articles became known, a great sensation was created in Germany. The high-handed manner in which the French conducted their negotiations, and the insolence and contempt with which they treated the empire, led to the recall of the Austrian ambassador from the convention in the beginning of 1799, and on the 13th of March France again declared war against Austria. In the meantime the latter power had entered into an alliance with England and Russia against the former. In Germany the Archduke Charles defeated Jourdan at Stockach (26th March), and in several other encounters, and drove him out of the country; and he afterwards reconquered the whole of the western portion of Switzerland to beyond Zurich from Massena. In Italy Scherer was defeated by the

Austrian general Kray at Verona and at Magnano, and then resigned the command into the hands of Moreau. The Russian army, under Suwaroff, now formed a junction with the Austrian, and the French were again beaten near Cassano (27th April). This was followed by other successes, so that in less than three months the French standards were driven back to the summit of the Alps, and the whole plain of Lombardy, with the exception of a few of its strongest fortresses, was recovered. After this the Russian general marched against Macdonald, who was advancing with a French army from Naples. A desperate conflict took place on the banks of the Trebbia, which was maintained with consummate bravery and skill for three days (17–19 June), until victory declared for the Russians. Out of 36,000 men in the field the French lost above 12,000 in killed and wounded, and the allies nearly as many. One place after another now fell into the hands of the allies; but mutual jealousies and divisions breaking out among them, the Russian and Austrian forces were eventually separated. This led to the most disastrous results. The Russians were to prosecute the war in Switzerland, while the Austrians remained to carry it on in Italy. In the meantime another French army had been collected under General Joubert; and, on the 16th of August he was attacked by the allies at Novi. The battle was long and obstinate, but at length the allies were victorious. The French lost their general, who fell mortally wounded, besides about 1500 killed, 5500 wounded, and 3000 prisoners. The loss of the allies was 1800 killed, 5200 wounded, and 1200 prisoners. The Russian general now directed his march towards the Alps, forced the St Gotthard, and descended into the valley of the Urseren, driving the French before him with great slaughter. With great difficulty and loss he effected a passage through the horrible defile of the Shichenenthal, between Altdorf and Mutten; but, at the latter place, instead of meeting the allied troops, as he had expected, he found himself in the midst of the enemy. Before this time Massena had so beset the Russian general Korsakoff at Zürich, that he was compelled to fight, and with difficulty made his escape with the remains of his army, while the Austrian forces under Hotze had also been beaten by Soult. Nothing remained for Suwaroff but retreat, a course which he adopted with extreme reluctance, making his way with incredible resolution and perseverance over the rugged Alps into Glarus and the Grisons, and at length reaching the valley of the Rhine (10th October). Disagreements having taken place between the Austrian and Russian generals regarding their future proceedings, the latter withdrew to winter quarters in Bavaria; and soon after this the capricious czar of Russia, Paul, withdrew from the alliance and recalled his troops.

Bonaparte, who had now returned from his Egyptian campaign, made proposals for peace, which were rejected, and both sides prepared to renew the contest in 1800. A numerous and well-appointed French army was collected at Dijon, at the head of which the first consul suddenly put himself, and set out for Italy across the Great St Bernard. The passage was effected with great skill and determination in spite of every obstacle, and he arrived in Lombardy before Melas, the Austrian general there, had been informed of the expedition. On the 14th of June a great battle took place near the village of Marengo, the most obstinate and sanguinary that had up to this time been fought. The Austrian army numbered 21,000 foot and 7000 horse, while opposed to them was an army of 22,000 men. The battle was maintained with great spirit and obstinacy on both sides; but at length, after repeated charges, the French were compelled to give way, and the retreat became general. At this moment, however, a fresh body of

French troops under Desaix arriving on the field the contest was renewed, and after a final struggle the Austrians were compelled to yield. They lost about 7000 men in killed and wounded, and 3000 prisoners; while the French lost about the same number in killed and wounded, and 1000 prisoners, taken in the early part of the day. Their retreat being cut off, the Austrians capitulated to the conqueror, who thus again acquired possession of the whole of Italy. In the meantime Moreau had invaded Germany and defeated Kray in several engagements, particularly at Stockach and Möskirch, and again at Biberach and Höchstädt; he also took Munich, and laid Bavaria and Swabia under contribution. An armistice was now agreed to (Paradorf, 15th July), and overtures were made for peace, but without success. Hostilities were resumed in the end of November, and at first the Austrians gained some advantages, but on the 3d of December they sustained a crushing defeat at Hohenlinden. The fight was long and obstinate; the French lost on that and the preceding days 9000 men, while the loss of the Austrians was nearly twice as great. The moral effects of the defeat were most disastrous. Moreau now advanced by hasty marches, crossed the Inn, took Salzburg, and pressed on towards Vienna, but an armistice was agreed to on 25th December. In Italy the Austrian forces sustained a severe defeat at the passage of the Mincio (26th December). Suffering under these disasters Austria was glad to agree to terms, which were concluded at Lunéville, 9th February 1801.

By this treaty the whole of the left bank of the Rhine was again ceded to France, and the Adige was declared to be the boundary of Austria in Italy; the grand duke of Tuscany, on the promise of an indemnity in Germany, renounced his dukedom in favour of the infant duke of Parma, created king of Etruria; the duke of Modena received the margraviate of Breisgau in exchange for his territory; and the independence of the Batavian, Helvetic, Cisalpine, and Ligurian republics was recognised and guaranteed. A convention was to be again summoned for the regulation and adjustment of the rights of all concerned. In order to provide indemnities for the despoiled princes, a large proportion of the ecclesiastical sovereignties of the empire was secularised, or, in other words, confiscated; and all the free imperial cities were deprived of their privileges with the exception of six. To the share of Prussia fell the bishoprics of Hildesheim and Paderborn, the city of Munster, and other cities and abbeys, to the amount of more than four times what she had lost on the left bank of the Rhine. Thus was she rewarded for her discreditable neutrality and impolitic desertion of the European alliance, though she subsequently suffered for this at Jena and by the treaty of Tilait. The grand duke of Tuscany received the archbishopric of Salzburg, the bishopric of Eichstätt, and part of that of Passau, in exchange for his hereditary possessions. Austria received the Tyrolean archbishoprics of Trent and Brixen. She had also received, in 1795, Western Galicia as her share in the third division of Poland, so that now her territory comprised over 254,000 square miles, her public debt amounting to 1,220,000,000 florins, or £122,000,000.

Austria now enjoyed a short period of peace, and employed it in silently repairing the breaches in her army and finances which had been produced by the late wars. After Napoleon had assumed the title of emperor of the French, the Emperor Francis took for himself and his successors that of emperor of Austria (11th August 1804). On 11th April 1805, an alliance was formed between England and Russia for resisting the encroachments of France, and some months later Austria and Sweden likewise joined it. Prussia held aloof, in the hope of receiving Hanover as a

reward for her neutrality; while Baden, Württemberg, and Bavaria sided with France. Deceived by the efforts that Napoleon was ostensibly making for the invasion of England, the Austrians (9th September) crossed the Inn, invaded Bavaria, and took up a position in the Black Forest. Meanwhile the French troops were in full march from the shores of the Channel to the banks of the Rhine; and the force in Hanover, under Bernadotte, was ordered to cross the Prussian territory without asking permission, and form a junction with the Bavarians in the rear of the Austrians, while other corps were at the same time directed by circuitous routes upon their flanks. The Austrian general, Mack, on the first intelligence of the approach of the French, had concentrated his forces at Ulm, Memmingen, and Stockach, contemplating an attack only in front. Great was his consternation, therefore, when he found that there was also an army on his rear. After several partial engagements, in which the Austrians were defeated, the Archduke Ferdinand, at the head of a body of cavalry, succeeded in making his way through the enemy, and in reaching Bohemia; while Mack, with the rest of the army, shut himself up in Ulm, which, with 30,000 men, he was forced to surrender (20th October). After this, Napoleon, with his usual rapidity, marched with the main body of his troops upon Vienna, and on the 5th of November established his headquarters at Linz, the capital of Upper Austria. The Russian and Austrian troops made various attempts to obstruct his farther progress (particularly at Dürrenstein, where a desperate engagement took place), but without success; and, on the 13th November, Vienna was in the hands of the conqueror, who made his headquarters at Schönbrunn. In the meantime the Archduke Charles was with the army in Italy, where, on 29th October, he was attacked with great fury on the heights of Caldiero, by the French under Massena. A terrible conflict ensued, and continued till night parted the combatants. It was renewed the following day, when at length victory declared for the Austrians. The archduke, however, was unable to avail himself of his success, for, hearing of the unfortunate state of matters in Germany, he set out with his army for the defence of the capital, and conducted it with great skill over the mountains, so that it suffered no serious loss. Marshal Ney, who had been sent with a body of troops into Tyrol, succeeded in taking the mountain barrier of Scharnitz by storm, and in making himself master of Innsbruck. Two bodies of Austrian troops had been so hard pressed that they were obliged to capitulate—one under General Jellachich at Feldkirch, and another under the Prince de Rohan at Castel-Franco in Italy.

After the loss of Vienna the allied forces collected themselves in Moravia, whither they were followed by Napoleon. At length the two armies came in sight of each other at Austerlitz, and both sides prepared for battle, which it was felt must be a most momentous one, and was to be witnessed by three emperors (those of France, Austria, and Russia). The allied forces numbered fully 80,000 men, of whom 15,000 were cavalry, while the French had 90,000 men in the field. The army of the allies was not well generated, while on the side of the French were Soult, Bernadotte, Davoust, Murat, Lannes, Oudinot, Bessières, &c. The battle commenced on the morning of the 2d December, and continued till night. Both sides displayed the greatest skill and bravery; at one part of the field the allies would be victorious, at another the French; at one time victory would incline to the French, and again to the allies. At length, however, towards evening, the allies came to be beaten at all points, and the route soon became general. Numbers sought to save themselves by crossing the frozen lake of Satschan; but shots from the French batteries on the heights above broke the ice in all directions, and about



2000 men perished. The allies lost about 30,000 men, killed, wounded, or made prisoners, while the French lost about 12,000 in killed and wounded. This was the most glorious of all Napoleon's victories; but he was still in a very dangerous position. The Archduke Charles, with an army of 80,000 men, was now approaching Vienna; Hungary was rising *en masse* against him; Russian reserves were advancing; and Prussia was at length preparing to declare war, on account of the unauthorised passage of French troops through her territories. From these difficulties, however, he was freed by the desire of the Emperor Francis for peace. An armistice was agreed to, and finally a treaty of peace was drawn up and signed at Presburg (25th December 1805). By this treaty Austria ceded to Bavaria, now erected into a kingdom, the whole of the Tyrol, Vorarlberg, Lindau, Burgau, Passau, Kichstädt, Trent, and Brizen, besides several petty lordships; to Württemberg, now also become a kingdom, the bordering Austrian dominions in Swabia; and to Baden the Breisgau, the Ortenau, and the town of Constance. She also yielded up her Venetian possessions, and agreed to pay a war contribution of £1,600,000. In exchange for all these sacrifices she merely received the small electorate of Salzburg, and the possessions of the Teutonic Order. In all, Austria lost about 28,000 square miles of territory, with a population of 2,700,000, and a revenue of 14,175,000 florins. It was evidently not the intention of Napoleon to overthrow the Austrian monarchy, but rather to throw its strength to the eastward, and to impose a barrier of subordinate kingdoms between it and France, so as to prevent its interference with his schemes of aggrandisement in Germany and Italy.

A blow was inflicted upon the constitution of the German empire by Napoleon, in the formation of the Confederation of the Rhine. Representatives of the different powers concerned assembled at Paris in the beginning of July 1806; and, on the 12th of that month, an Act was signed whereby the kings of Bavaria and Württemberg, the elector of Baden, and thirteen other princes of Western Germany, separated themselves from the German empire, and formed a confederation under the protection of the emperor of the French. 16,000,000 men were thus, by a single stroke, transferred from the empire to a foreign alliance. Wisely yielding to what he could not prevent, the Emperor Francis, by solemn deed, renounced the title of emperor of the Romans, and declared himself the first of the emperors of Austria.

The peace of Presburg was quickly followed by the war between France and Prussia, in which the latter suffered terrible retribution for her selfish policy in leaving Austria to struggle unaided against the common foe of Europe. Great efforts were made to induce Austria to take part in this war, but she prudently remained neutral, contenting herself with making every effort to strengthen and improve her army, and increase her warlike resources. During the whole of 1806 and 1807 the efforts of the war department, under the guidance of the Archduke Charles, were incessant to restore the losses that had been sustained in the late war. The army was also remodelled upon the system adopted by Napoleon. The transfer of a large portion of the French army in Germany to the Peninsula on the breaking out of war there, emboldened the Austrian Government to issue a decree (9th June, 1808), instituting a *landwehr* or militia to be raised by conscription, which soon amounted to 300,000 men, in addition to a regular standing army of 350,000. On hearing of this, Napoleon addressed strong remonstrances to the court at Vienna, which made loud professions of pacific intentions, but did not cease its warlike preparations. In the spring of 1809 the armies on both sides took the field, and, on 8th April, Austrian troops crossed the frontiers at once in Bohemia,

on the Inn, in the Tyrol, and in Italy. In the meantime France was bringing together her forces from all quarters towards the valley of the Danube, where at length she had an army, including the troops of the German Confederation, of about 200,000 men, and Berthier was despatched to take the command till the arrival of the emperor. The Archduke Charles had crossed the Inn with upwards of 120,000 men, and on the 16th they had advanced as far as the Isar, which they crossed. Berthier, instead of concentrating his troops, was separating them, so that they were in the utmost danger, when the arrival of Napoleon at once changed the aspect of affairs. On the 19th an action took place at Thann, between a body of about 20,000 French and a like number of Austrians, without any decisive result; and the following day the main body of the Austrians, over 50,000 strong, was suddenly attacked and defeated after a feeble resistance at Abensberg, by a French army of 65,000 men. The same day the Austrians attacked and took Ratisbon, and secured the bridge over the Danube there. Both sides now prepared for a general engagement, which took place at Eckmühl on the 22d of April. The battle was bravely contested; but at length the French were victorious, the loss to the Austrians being 5000 killed and wounded, and 7000 prisoners. The archduke retired during the night to recruit his army in Bohemia, and Ratisbon was taken by storm. In other parts, particularly in Italy, success was attending the Austrian arms.

Napoleon now lost no time in again marching on to Vienna, and no great attempt was made to impede his progress except at Ebersberg, where Hiller with about 30,000 Austrians took his stand to defend the wooden bridge over the Traun. He was gallantly attacked by a body of French troops under Massena, and a fearful struggle took place; but at length the French prevailed, and Hiller withdrew his troops. Each side lost about 6000 men on this occasion. On the 10th of May the French eagles appeared before the walls of Vienna, and, after an ineffectual attempt at defence, the city surrendered on the 13th. The Archduke Charles was hastening to the relief of the town, but arrived too late. The two armies therefore prepared for battle, the one on the north bank of the Danube, the other on the south. On the night of the 19th the French prepared to cross the river at the island of Lobau, and by daybreak on the 21st they had 40,000 men landed on the northern side. The Austrians now resolved upon an attack, and by two o'clock, when the fight began, the French force amounted to about 50,000 men, while the Austrians had 80,000 to oppose them. The scene of action was near the villages of Aspern and Essling, and the struggle was maintained with the most desperate courage on both sides till night parted the combatants. The Austrians had everywhere the advantage, but both sides prepared to renew the contest the next day. During the night, and early in the morning, French troops were still passing over, so that, notwithstanding his losses, Napoleon had fully 70,000 men to renew the fight. It commenced early in the morning, and continued the greater part of the day; but at length the French were beaten on all sides, and compelled to retreat to the island of Lobau. In these two days they lost upwards of 30,000 men, and the Austrians not less than 20,000. The victory produced a great impression on the mind of Europe, and dissipated in a great degree the charm of Napoleon's invincibility.

He, however, made every preparation for renewing the contest. He summoned troops from different parts, and fortified his position on the island of Lobau, connecting it also by several bridges with the south bank of the river. On the evening of the 4th of July he assembled his troops on the island, amounting to 150,000 infantry and 30,000

cavalry, with 750 pieces of cannon. During the night several bridges, which had been secretly prepared, were thrown over to the northern bank at a point where they were not looked for, and by six o'clock the following morning the whole body had passed over. In the afternoon the French made a vehement attack upon the Austrians, but were repulsed with great slaughter. Early on the morning of the 6th the Austrians began the attack. Their numbers were then about 115,000 infantry and 25,000 cavalry; but they were in hourly expectation of the arrival of an additional body of 30,000 under the Archduke John, which was known to be not far off. The battle was contested with the utmost determination and bravery on both sides. The Austrian right wing succeeded in overthrowing and putting to flight the left wing of the enemy. On the other wing the contest was long and doubtful; but two divisions of troops having at length succeeded in turning the extreme flank of the Austrians, the latter, after a gallant defence, were compelled to abandon their position. In these circumstances, Napoleon collected all his disposable forces and brought them to bear upon the centre of the Austrians, which was their weak point, the archduke having thrown his strength chiefly into the two wings. After repeated charges, which were repulsed with great bravery, the French succeeded in forcing their line, and the archduke, despairing of maintaining his position, ordered a retreat, which was effected in good order and with little loss. The French were so exhausted that they displayed little vigour in the pursuit, and neither guns nor prisoners were taken. The Archduke John came up in the afternoon, but too late to be of any service. Had he made his appearance sooner there can be no doubt that the result would have been different. As it was, the Austrians succeeded in making a most gallant stand against a greater number of the best troops of France, led by Napoleon and some of his greatest generals. This battle of Wagram was one of the greatest and most obstinately contested fights in the whole war, and is perhaps the most glorious in the annals of Austria. The loss on both sides was immense, amounting to about 25,000 on each, including killed and wounded. The Archduke Charles retreated towards Bohemia without any serious molestation from the enemy. A battle was fought at Znaim (11th July) between the Austrians and a French army under Massena which was following them, but before it was decided news of an armistice arrived. This was followed by the peace of Vienna (14th October). "The campaign of Aspern and Wagram," says Sir A. Alison, "is the most glorious in the Austrian annals,—one of the most memorable examples of patriotic resistance recorded in the history of the world. . . . Other empires have almost invariably succumbed upon the capture of the capital. . . . Austria is the only state recorded in history which (without the aid of a rigorous climate like Moscow) fought two desperate battles in defence of its independence after its capital had fallen."—(*History of Europe*.) By the peace of Vienna Austria was compelled to cede Salzburg, Berchtesgaden, the Innviertel, and the Hausruckviertel, to Bavaria; portions of Galicia to Russia and the grand duke of Warsaw; and Carniola, Trieste, the greater part of Croatia, Istria, the circle of Villach, &c., to Italy. In all she lost about 42,000 square miles of territory and 3,500,000 inhabitants, together with more than 11,000,000 florins of revenue. The emperor also agreed to reduce his army to not more than 150,000 men; and a war contribution of £3,400,000 was imposed on the provinces occupied by the French troops. Before leaving the Austrian capital Napoleon caused the fortifications to be blown up.

Soon after this Napoleon obtained a divorce from his wife Josephine, and offered his hand to Maria Louisa,

daughter of the emperor of Austria, and was accepted. The marriage was celebrated with great pomp at Vienna on the 11th March 1810. In 1812 Austria was obliged to enter into an alliance with France against Russia, and to furnish an auxiliary force of 30,000 men for the invasion of the latter country. The disastrous result of that expedition to the invaders showed Germany that the fortunate moment had now arrived for regaining her independence. Prussia was the first to form an alliance with Russia, and declared war against France (17th March 1813). Great efforts were made to induce Austria to join this alliance, but without success. She directed her attention to raising her military strength, and making other preparations to enable her to take an important part in the coming struggle, on the one side or the other. After the defeat of the allies at Lützen and Bautzen, and the conclusion of an armistice at Pleswitz, Austria came forward as a mediator, with the view of effecting a peace between the parties, and not without the view, also, of gaining some material advantage for herself. In fact, she now held in her hand the balance between the contending parties. Her army of 150,000 or 200,000, which she had collected in Bohemia, would bring victory to whatever side she joined. Metternich, who at that period had the direction of the cabinet of Vienna, was too clear-headed not to perceive the advantages of the position, and he determined to avail himself of them, in order if possible to restore to Austria her lost possessions. He had openly avowed, that if Napoleon would accede to the terms which he proposed Austria would throw her whole 200,000 men into the scale in his favour. At first it seemed doubtful to which side she would attach herself; but it would appear that the allies had reason to believe that she was favourable to them, and that Napoleon had also reason for suspecting the strength of her attachment to him. It is evident that she would have more to expect from the allies than from Napoleon, but at the same time it was doubtful how far she would be influenced by the existing matrimonial alliance. While things were in this doubtful state news arrived of the battle of Vitoria, by which the death-blow was given to the power of France in the Peninsula, and after this there was little hope of peace on either side. Austria, whatever her previous intentions, doubtless now felt that there was little to be gained from attaching herself to a sinking empire and a falling cause, and she agreed, in the event of Napoleon not accepting the terms proposed, to join the allies. They could have had little hope that the terms would be accepted; they included the cession to Austria of all the Illyrian provinces, with Trieste, the reinstatement of Prussia in her ancient possessions, with a frontier on the Elbe, and the dissolution of the grand duchy of Warsaw, to be divided between Russia, Austria, and Prussia. These terms not being acceded to, both parties prepared for war. Austria agreed to furnish 200,000 to the allied forces, stipulating in return that she should be restored to the condition in which she was in 1803, or, at any rate, at the peace of Presburg.

By gigantic efforts Napoleon was able to raise his army to 400,000 men, of whom nearly 350,000 were effective, and he resolved to make Dresden the pivot on which all his operations should turn. To oppose him the allies mustered about 400,000 men, so that the two forces were pretty nearly equal. Of the latter, a grand army of 220,000 men, chiefly Austrians, under Prince Schwarzenberg, was stationed in Bohemia; Blücher, with 95,000 men, was to protect Silesia; while Bernadotte, the crown prince of Sweden, who had joined the allies with 28,000 troops, was to protect Berlin and Brandenburg with an army of 90,000. Napoleon resolved to march with the main body of his troops into Silesia against Blücher, having despatched an army of 80,000 men under Oudinot against Berlin, and

sending a force of 30,000 to keep the passes from Bohemia to Dresden. Blücher judiciously retreated before the French troops, and while Napoleon was following him, the allied army in Bohemia came down upon Dresden. In place, however, of at once beginning the attack, it was delayed till Bonaparte, who had been informed of their movements, had time to arrive. The attack was commenced on 28th August, and kept up with great fury during the day; but in the evening a series of sallies were made from the town, which took the besiegers completely by surprise, and compelled them to withdraw. Napoleon had now received sufficient reinforcements to enable him to give battle, which he did the next day. He was then able to muster 130,000 men, while the allies numbered about 160,000. The fight was maintained for some time with great bravery on both sides, but at length a body of French troops under Murat succeeded in turning the flank of the allied left wing, and then attacking them suddenly on flank and rear; they were thus thrown into confusion, and the great body of them killed or made prisoners. The allies lost on this occasion about 26,000 men, of whom about 13,000 were prisoners. A French force under Vandamme had been sent to cut off the retreat of the allies, but this was engaged near Culm (29th August) by a body of Russians under Ostermann, and a desperate struggle took place, which was renewed the next day, and only ended by the appearance in the rear of the French of a large body of Prussians, when the leader and most of his troops were made prisoners. The French lost in the two days 18,000 men, of whom 7000 were prisoners.

Napoleon, on quitting Silesia, had left Maedonald with an army of 80,000 men to oppose Blücher. The latter suddenly attacked them with great fury on the Katsbach (26th August), and defeated them with great slaughter. The fight was several times renewed during the three following days when the allies were in pursuit, and in all the French lost about 7000 men in killed and wounded, and 18,000 prisoners. Nor was the French army under Oudinot more successful, for it sustained a severe defeat at Gross Beeren (23d August), and in that and subsequent engagements lost about 4000 in killed and wounded, and an equal number of prisoners. Napoleon was strongly affected by these reverses, the more so that they were quite unexpected. He gave the command of the army in the north to Ney, and set out himself against Blücher. Ney engaged the allied army at Dennewitz, and a desperate battle was fought (6th September), in which the French were at length beaten and put to flight with a loss of 13,000 men, of whom one-half were prisoners. The army in Bohemia now again resumed the offensive, and was preparing to fall upon Dresden, when Napoleon suddenly returned and drove them back. He again marched against Blücher, but returned to Dresden without effecting anything. He then resolved to enter Prussia and take Berlin, but was obliged to give up this project on learning that Bavaria had joined the allies (8th October). Now fearing that his retreat might be cut off, he directed his march towards the Rhine, and reached Leipsic on the 15th of October. Here the combined allied armies under Schwarzenberg, Blücher, and Bernadotte assembled, and on the 16th an indecisive battle was fought, which to the French was equivalent to a defeat, and the same evening Napoleon made proposals for peace, but no answer was returned. The battle was renewed on the 18th. The French army numbered about 175,000 men, while the allied forces amounted to about 290,000. The French strength was also weakened by two Saxon brigades of foot and one of cavalry passing over to the enemy during the engagement. Notwithstanding these disadvantages the French fought with great bravery and determination but were at length

beaten on every side. Next day they were in full retreat, and Leipsic was taken by the allies after a gallant defence. The total loss of the French during these four days exceeded 60,000 men. The emperor reached Erfurt on the 23d October, and there collected the scattered remains of his army. The Bavarians, under Wrede, attempted to intercept his retreat at Hanau, but though aided by some of the allied troops, they were defeated with great slaughter (30th October). The Rhine was crossed on 1st November, and on the 9th Napoleon arrived in Paris. Thus Germany regained its independence, and the Confederation of the Rhine was dissolved. Austria, as we have seen, had a principal share in bringing this about; but the Emperor Francis was opposed to the adoption of extreme measures against Napoleon, being desirous that the sceptre of France should continue in the hands of his daughter and her descendants. Other views, however, prevailed. The war was carried into the enemy's country, and at length, not without a good deal of fighting, the allies entered Paris on 31st March 1814. On 11th April Napoleon resigned the imperial crown.

In the end of September following a congress was assembled at Vienna to adjust the claims and the mutual relations of the several states. This, however, was found to be a matter of no small difficulty. Russia demanded the whole of Poland, and Prussia had claim to Saxony. Austria, France, and England were opposed to these claims, and determined to resist them, so that at one time it appeared as if war was again to break out; but more peaceful views began to prevail, and when the news arrived that Napoleon had secretly quitted Elba, all minor differences were forgotten in the presence of this pressing danger. They at once declared him an enemy and a disturber of the peace of the world, and prepared to bring against him an army of upwards of half a million of men. But before these had all been collected, Wellington and Blücher had brought the military career of Bonaparte to a close on the field of Waterloo. In the new partition of Europe, which was fixed by the Congress of Vienna (1815), Austria received Lombardy, and Venice, the Illyrian provinces, Dalmatia, the Tyrol, Vorarlberg, Salzburg, the Innviertel, and Hausruckviertel, together with the part of Galicia formerly ceded by her, making in all about 3,200 square miles of territory.

The emperors of Austria and Russia and the king of Prussia also entered into a "Holy Alliance," by which they bound themselves to remain united in the bands of true and brotherly love, to mutually help and assist each other, to govern their people like fathers of families, and to maintain religion, peace, and justice in their dominions. This alliance, beautiful in theory, was made, in fact, the means of maintaining absolute power in the hands of the rulers, and of suppressing free institutions and almost every form of liberty among the people. This was particularly the case in Austria, under the direction of Metternich, who did everything in his power to carry out these principles. A strict censorship of the press was established, not only to overlook the home press, but also to superintend the introduction of foreign publications. A system of secret police was also organised to observe and report what was said and done by the people in private. Besides this, Austria was ever ready to aid in the suppression of revolutionary movements in other states. In the construction of the German Confederation she used her influence to suppress the popular voice in all matters of government; her armies were employed in quelling the popular insurrections in Naples and Piedmont in 1822; and by diplomacy she aided in the suppression of the popular movement in Spain in 1823. During the insurrection in Greece the influence of Austria was exerted against it; and when Greece was established as a kingdom (1827), under the protection of England,

France, and Russia, she kept aloof. When, however, Russia invaded Turkey in 1828, Austria joined with England in interfering to prevent the fall of Constantinople, and in bringing about peace.

The commotions that followed the French revolution of July 1830 in different parts of Europe considerably affected Austria. This manifested itself chiefly in Lombardy, where the presence of 30,000 troops was required to maintain the imperial authority. In Parma and Modena the people suddenly rose in insurrection and expelled their rulers, and Austrian troops were employed to restore them. An insurrection also broke out in the Papal States, and the Pope invoked the aid of Austria, whose troops entered Bologna and established themselves there (January 1832). Upon this the French sent a force to occupy Ancona, and at one time it seemed as if France and Austria were again to cross swords on Italian soil, but this danger was at length averted. In the minor states of Germany the cry for popular institutions was raised, and in many cases the rulers were obliged for a time to comply with them, but after the danger appeared to pass away, Austria, acting in concert with Prussia, succeeded in bringing back the old state of things in the confederation. The Poles, tired of Russian rule, and hoping to be supported by France, took up arms to regain their independence (1831). Although Austria professed a strict neutrality in the struggle, a Polish corps that was driven into her territories was disarmed and detained, while a body of Russian troops under the same circumstances was allowed to continue its operations against Poland. During the remainder of the reign of Francis I. no public event of importance occurred. He died on the 2d of March 1835, in the sixty-seventh year of his age and the forty-third of his reign. He was one of those well-meaning but weak-minded men, who unfortunately adopt the wrong means for effecting the good which they intend. He wished to make his people contented and happy, but he sought to do so by repressing all independence in thought or action, and keeping them in the most abject subjection. He earnestly strove for their advancement, but it was by strenuously endeavouring to keep things as they were, and opposing every form of change. The transition from an old to a new state of things was in his mind always associated with the utmost danger, and to be by all means avoided. He did much in the way of establishing elementary schools throughout the country, but said that he wished to have no learned men, only good loyal citizens. He was thoroughly conscientious and correct in his conduct, but at the same time narrow-minded, suspicious, and bigoted. He was most assiduous in his attention to the business of the state, but occupied himself chiefly with small matters and minor details, while more important concerns were entirely overlooked and neglected. His good qualities, however, commended him to the affections of his people, and this doubtless did much to repress among his subjects the insurrectionary spirit which subsequently manifested itself.

He was succeeded by his eldest son, Ferdinand I., an amiable but weak-minded prince, who left the government very much in the hands of his prime minister, Metternich. The various signs of discontent which had been manifested during the former reign soon became stronger and more marked. Byron Pillersdorf, the successor of Metternich, speaking of this period, says, "Circumstances permitted an uninterrupted enjoyment of peace, but the necessity for internal ameliorations became by so long a delay more urgent, the demand for them more sensible, whilst, owing to the procrastinations of the Government, faith and confidence were diminished. It is true that the prosperity of the provinces generally did not decline; on the contrary, many branches of commerce manifested an increase in their

development; but in spite of this the situation of the whole empire inspired in different respects serious apprehensions, arising from the disordered state of the economy of finance, the yearly augmentation of the public debt, the inefficiency of the measures adopted, and still more from the oppressed disposition of mind of the clear-sighted and intelligent classes of the population."—(*The Political Movement in Austria during 1848-49.*) The people saw growing up in the nations around them freer institutions and more liberal modes of government, and they could not help contrasting those with their own system. Austria, too, was made up of a number of different nationalities, and the Government attempted to strengthen its position by working upon their national prejudices and antipathies, setting race against race, and creed against creed. In particular, the German element was favoured at the expense of the other nationalities; and the Germanising measures of the Government excited great discontent among the other races. It has been remarked that the aversion of Austria to the development of the Slavonic element in her population was greatly owing to jealousy of Russia, which power she regarded as desirous of attaching all the Slavonic races to itself. Hence Austria has always been opposed to the encroachments of Russia in Turkey, and in favour of maintaining the integrity of the latter, so that, when war broke out in 1839 between the Sublime Porte and the Pasha of Egypt, she readily joined England in support of the former.

The court of Vienna was first frightened from its sense of security by an insurrection in Galicia in 1846. This having been suppressed, Austria, in conjunction with the other two powers which had dismembered Poland, determined to lay hold on Cracow, and thus extinguish the last remnant of Polish independence. This step being contrary to the treaty of Vienna, was strongly remonstrated against both by England and France; but these remonstrances were unheeded, and the republic was incorporated in the Austrian empire. The French revolution of 1848, which convulsed almost the whole of continental Europe, caused the Austrian empire to totter to its foundations. Scarcely had the news of the fall of Louis Philippe reached Vienna when the whole city was in a state of open rebellion (13th March). The populace, headed by the students, and forcing the magistracy along with them, made their way into the imperial palace, and loudly demanded from the emperor the dismissal of his old counsellors, and the immediate grant of a new constitution. Alarmed at these demonstrations Prince Metternich resigned, and was soon after on his way to London; and an imperial proclamation was issued, declaring the abolition of the censorship of the press, the establishment of a national guard, and the convocation of a national assembly. These measures, however, as well as the nomination of a new ministry, were far from sufficing to arrest the popular movement, encouraged and led on by the students and other members of the university. The national guard just called into being, along with the academic legion, formed themselves into a permanent committee, and dictated laws to the Government. On the 17th of May, Ferdinand, accompanied by the empress and the members of his family, secretly quitted the palace, and fled to Innsbruck. An attempt to dissolve the academic legion caused an outbreak on the 25th, and the streets were barricaded; but no fighting took place, for the ministers yielded to the demands of the rioters, and gave up their design. A committee of citizens, national guards, and students, which was formed for the preservation of peace and order, was legalised by the prime minister, and assumed the authority of the Government. In the meantime the revolutionary spirit was manifesting itself in other parts of the empire. In Italy the inhabitants of

Milan and Venice rose against their rulers, and expelled the Austrian troops. This was followed by a general rising throughout Lombardy and Venice. The insurgents found an ally in Charles Albert, king of Sardinia, who came with an army to their assistance, and declared war against the empire. At first he succeeded in driving the Austrians back to the northern frontier of Italy; but General Radetzky, having received reinforcements, vanquished him in several engagements, and compelled him to flee to his own dominions, and conclude a truce with the victors. This was followed by the reconquest of Milan and the whole of Lombardy. Venice withstood the besieging army of the Austrians for some months, but was at length obliged to surrender. In Bohemia the Czechs or Slavonic party determined to obtain redress against the Germanising measures of the Government, and forwarded a petition to the emperor, demanding a united and independent national assembly for Bohemia and Moravia, independent municipal institutions, and an equal share in public offices with the German part of the population. An evasive answer was returned, and the citizens of the capital rose in insurrection. A national assembly of delegates of the Slavonians in all parts of the empire was summoned to meet at Prague. Three hundred made their appearance, and the assembly was opened in the beginning of June. The efforts of the military to maintain peace excited the enmity of the citizens, and they petitioned for the removal of the commander, Prince Windischgrätz. Meanwhile a collision took place between the Slavonic militia and the regular troops. The Germans joined with the military, and the insurrection raged for five days; the town was bombarded and taken, and the leaders dispersed or taken prisoners.

In Hungary the National Diet had passed measures in favour of a responsible ministry, a perfect equality of civil rights, religious toleration, the formation of a national guard, and abolition of the censorship of the press. The emperor gave his consent to these measures; but a strong Austrian party in the country, chiefly Slavonians, was opposed to them, and, instigated and supported by the Austrian Government, they broke out in open revolt. Jellachich, the ban or governor of Croatia, was the leader of the insurgents, and collecting an army of 65,000 men, he marched on towards Pesth. An army was speedily raised by the Hungarians to meet him, and a battle was fought within 25 miles of the capital on 29th September, in which Jellachich was beaten. The emperor now openly declared against the Hungarians, annulled the decrees of the Diet, suspended the civil authorities, and appointed Jellachich commander of the army. The Diet, denying the authority of the emperor, organised a committee of safety, and elected Kossuth president. This was equivalent to a declaration of war, and an Austrian army was ordered out against them. The people of Vienna, sympathising with the Hungarians, rose in arms, when the garrison of that city departed for Hungary (6th October). A deputation waited on the minister of war, Latour, demanding their recall, and on his refusal they took the arsenal by storm, and murdered him. The National Diet, which had met on the 22d of July, now declared its sittings permanent, and elected a committee of public safety. It sent an address to the emperor asking for a new ministry, the revocation of the edict against the Hungarians, the dismissal of Jellachich, and an amnesty for the rioters. The emperor, who had returned from Innsbruck to Vienna in June, returned an evasive answer, and fled to Olmütz. The people in the capital armed themselves under the leadership of General Bem, and prepared to resist the impending attack of the army. The garrison, after having retired outside the limits of the city, was joined by Jellachich's

horde of Croats and by the army of Windischgrätz. On 23d October, an army of 100,000 men appeared before Vienna, and the city was summoned to surrender. This the people refused to do, and the attack was commenced on the 28th, when the city was set on fire in many places. The next day a part of the suburbs was taken, and the leaders began to think of surrendering when the news of a Hungarian army hastening to their relief inspired them with fresh courage. This force, however, was attacked and put to flight by Jellachich (30th October), and next day the city was taken by storm, after a desperate struggle, which was attended with immense slaughter. On 22d November a new ministry was formed, of which Prince Schwarzenberg was president; and on 2d December the Emperor Ferdinand was induced to abdicate the throne. His brother, Francis Charles, who was his legal successor, likewise renounced his right in favour of his son, Francis Joseph, who was proclaimed emperor under the title of Francis Joseph I.

The war in Hungary was renewed by Windischgrätz, who crossed the Leitha, and after several successful engagements entered the capital of that country (January 1849), the Hungarian Government and one division of the army having departed eastward to Debreczin, while the other under Görgei retired northward towards Waitzen. The Austrian general, instead of pursuing them, remained inactive for seven weeks at Pesth, and thus afforded them time to organise. In Transylvania General Bem gained a decisive victory over the Austrians in that territory, and also defeated and put to flight a Russian force that had come to their assistance. At length Windischgrätz moved forward towards Debreczin, and met the Hungarians at Kapolna, where an obstinate and bloody but indecisive battle was fought (26th February). Next day the Austrians, having received reinforcements, renewed the fight, and the Hungarians were obliged to retire. The latter having recruited their forces, another obstinate battle was fought near Gödölö (5th April), in which the Austrians were defeated, as they were in several subsequent engagements, so that they were compelled to abandon the capital and recross the Danube, leaving a small garrison at Buda, which afterwards surrendered. Had the victorious army now marched on to Vienna they would doubtless have succeeded in bringing the Austrians to terms; but disputes among the rulers and dissensions among the generals prevented such a course. In June Prince Paakewitch crossed the Galician frontier at the head of a Russian army of 130,000 men; and General Haynau, who now had the command of the Austrian troops, was joined by a Russian corps under General Palutin. The Hungarians were unable to contend against these forces, and had again to leave their capital, the seat of the Government being transferred to Szegedin. Driven from this place, the army made a stand at Temesvar, but were defeated with great slaughter (9th August), and again, two days later, at Arad. On 13th August the Hungarian general, Görgei, who had been named dictator, surrendered to the Russians. Hungary was now treated as a conquered country, and the greatest cruelties were practised against the people by the Austrian general, Haynau. The military and parliamentary leaders were shot or hanged, and the prisons filled with unhappy victims. In the meantime the war in Italy was renewed by the king of Sardinia. He was, however, defeated at Mortara (21st March) by the Austrian general, Radetzky, and again at Novara (23d March), when he abdicated in favour of his son, Victor Emmanuel, with whom a peace was concluded. Venice held out against the Austrians till 23d August, when it was forced to surrender.

The congress which, since the final struggle in Vienna, had been adjourned to Kremsier, was dissolved (March 4,

1849), and a constitution promulgated by the free will of the emperor. At this time efforts were made in the German National Assembly at Frankfort to form Germany into one integral empire, excluding Austria, the imperial crown being offered to the king of Prussia. This was violently opposed by the Austrian Government, and though the king of Prussia did not venture in the face of this opposition to accept the imperial crown, he concluded a treaty with the kings of Saxony and Hanover (May 1849), with the view of forming a strict union with the different states of the German confederacy to the exclusion of Austria. To this treaty the majority of the lesser states afterwards acceded, and a diet was convened at Erfurt (May 1852), under the presidency of Prussia, for the reorganisation of Germany. Austria, to counteract the efforts of her rival, invited the different states to send their representatives to Frankfort, where she assumed the lead. The legality of the assembly was at once acknowledged by Bavaria, and Saxony and Hanover were subsequently gained over to it. While matters were in this state disturbances arose in Hesse-Cassel. The margrave invoked the assistance of Austria, while the people looked for aid to Prussia. Having received the authority of the diet at Frankfort, Austria sent an army into Hesse, where they were confronted by another army from Prussia, and an immediate commencement of hostilities was looked for, but this was averted by a conference held at Olmütz, when Prussia acknowledged the right of Austria to enter Hesse. Soon after this Austria and Prussia convoked a congress of all the states at Dresden, where it was agreed that the final settlement of the affairs of the confederacy should be submitted to the decision of the diet at Frankfort. Austria now proposed to the diet that all her provinces, including Hungary and Lombardo-Venetia, should be included in the German confederacy, but this bold proposal failed of acceptance.

Austria now made strenuous efforts to develop the resources of the monarchy by encouraging agriculture, industry, and commerce. The land was freed from the burdens of feudalism, taxes were removed, new roads were formed, and railways were constructed. A new tariff was adopted (July 1851), and negotiations were entered into with the other German states for a complete customs' union with the Zollverein, but this was strongly opposed by Prussia and several of the other states in the union. A commercial treaty, however, was, after considerable negotiation, concluded between Austria and the Zollverein (19th February 1853). The liberal concessions that had been made by the Government were rapidly disappearing, a rigorous military system of rule was being introduced, and centralisation was taking the place of the old provincial system. On the 1st of January 1852 it was announced that the constitution and fundamental rights were abolished, the ministers were declared responsible only to the emperor, trial by jury was set aside, the censorship of the press was again in operation. The influence of the Roman Catholic clergy and the Jesuits was also re-established. A popular outbreak occurred in Milan (6th February 1853), when a number of the military were killed, but it was speedily suppressed. An attempt was made to assassinate the emperor in Vienna by a young Hungarian (18th February). In the quarrel between the Montenegrins and the Porte, Austria sided with the former, and Count Leiningen was sent to Constantinople (February 1853) to demand the redress of their grievances, which was granted. About this time Russia demanded the protectorate of the Greek Christians in Turkey, and this being denied, her troops crossed the Pruth and occupied the principalities of Moldavia and Wallachia (July 1853). Austria took a leading part, along with France and England, in condemning these proceedings and in endeavouring to bring about peace. She also gave the Western powers to believe that

she would actively co-operate with them in the defence of Turkey, but afterwards fell back upon vague promises, and on April 20, 1854, entered into an alliance with Prussia, by which the two powers guaranteed each other's dominions from attack, and pledged themselves only to take an active part in the war when the interests of Germany appeared to be endangered. On June 14th Austria agreed with Turkey to occupy the Danubian principalities with an armed force, and by the end of August she had a large army there, which virtually brought the war on the Danube to an end. Austria still continued to use her exertions to bring about peace, and with this view a conference was opened at Vienna in March 1855, but the representatives of the several powers were unable to agree upon a basis. After the fall of Sebastopol she again renewed her efforts, and having ascertained the terms on which the Western powers would be prepared to treat, she sent Count Esterhazy to St Petersburg to lay them before the czar, by whom they were accepted, and a treaty of peace was signed at Paris, 31st March 1856.

In August 1855 the emperor signed a concordat with the Pope, giving the church greater power in the country than it had ever possessed before. The clergy were to have unlimited control over all ecclesiastical matters and matters connected with education, and were to enjoy free communication with Rome without the intervention of the civil power. The Government now seemed desirous of relaxing somewhat their restrictions, and of making the people forget the troubles of 1848 and 1849. The military rule was made less strict, and a general amnesty was proclaimed for political offences (12th July 1856). The emperor visited Italy in the end of 1856 and Hungary in May 1857, but the remembrance of past wrongs was still alive in the minds of the people, and he was everywhere received with the greatest coolness. Austria was opposed to the union of the Danubian principalities, and for some time refused to evacuate them, but at length (March 1857) her troops were recalled.

Sardinia had frequently remonstrated with Austria concerning her policy in Italy, while Austria, on the other hand, complained of the attacks made upon her by the Sardinian press. A growing coolness had also sprung up between Austria and France on this subject, which reached its climax when the French emperor said to the Austrian minister, M. Hübner, at the levee on the 1st of January 1859, "I regret that our relations with your Government are not so good as they were; but I request you to tell the emperor that my personal feelings for him have not changed." The preparations for war were carried on with the greatest activity by Austria, France, and Sardinia. England sent Lord Cowley to Vienna to endeavour to arrange differences, but without success. Russia proposed a congress of the five great powers, and this was agreed to, but Austria demanded the disarmament of Sardinia previous to the congress, which the latter declined to agree to, and both sides prepared for war. Austrian troops poured into Italy, France was concentrating her forces at Toulon, and Garibaldi was organising a corps of Italian volunteers. The Austrians crossed the Ticino (April 26), and the French troops were marched into Italy. Napoleon left Paris on the 10th of May, and reached Genoa on the 12th, where he was next day joined by Victor Emmanuel. The first serious encounter took place at Montebello (May 20), when a strong body of Austrians was, after a desperate resistance, defeated and put to flight by a body of French troops. The Austrians again suffered a severe defeat at Palestro (May 31). On 4th June the battle of Magenta was fought, in which the Austrians were, after a long and desperate conflict, defeated and put to flight by the combined army of the French and Sardinians, under the command of the

Emperor Napoleon in person. The Austrians fought with great bravery and determination, but were not well officered, and the arrival of General M'Mahon with his troops at an opportune moment decided the battle against them. They had about 75,000 men in the field, while the allies numbered about 55,000. The latter lost about 4000 men in killed and wounded, the former about 10,000, besides 7000 prisoners. Next day the inhabitants of Milan rose in insurrection, and the garrison fled. Pavia was evacuated on the 7th, and on the 8th the fortified position of Melegnano was taken after three hours' hard fighting. The same day the allied monarchs made their triumphal entry into Milan. One stronghold after another now fell into the hands of the conquerors. The defeated army retreated to the further bank of the Mincio, where it was reorganised, and the emperor himself assumed the command. It then recrossed the Mincio, and took up a position near the village of Solferino. Here the allies came up to it, and both sides prepared for battle. The Austrian army numbered about 170,000 men, while the allied troops were not less than 150,000. The battle commenced early in the morning of the 24th June, and continued till late in the afternoon. The Austrian line extended for nearly 12 miles. The right and left wings of the Austrians were for some time successful; while Napoleon was using every effort to break their centre. In this he was at length successful, and the wings were then obliged to retire in order that they might not be overflanked. The French lost in killed and wounded 12,000 men, the Sardinians 5000, and the Austrians 20,000, besides 7000 prisoners. The Austrians now abandoned the line of the Mincio, and fell back upon Verona. The allies crossed the Mincio, Peschiera was invested, and great preparations were made on both sides for renewing the contest. While all Europe was in the expectation of another great battle, news arrived that an armistice for five weeks had been agreed to; and on 11th July the two emperors met at Villafranca, and agreed to terms of peace. A conference was afterwards held at Zürich, and a treaty drawn up and signed (10th November 1859). By it Austria gave up Lombardy, with the exception of the fortresses of Mantua and Peschiera, to Napoleon, who was to hand it over to the king of Sardinia; Italy was to be formed into a confederation under the presidency of the Pope, and Austria was to be a member on account of Venetia; and the princes of Tuscany and Modena were to have their possessions restored to them.

In March 1860 the emperor, by patent, enlarged the number and powers of the Reichsrath or council of the empire, and on 21st October promulgated a new constitution, in which he declared the right to issue, alter, and abolish laws, to be exercised by him and his successors only with the co-operation of the lawfully assembled diets and of the Reichsrath. The things to be settled with the co-operation of the Reichsrath were all legislative matters relating to the rights, duties, and interests of the several kingdoms and countries, such as the laws connected with the coinage, currency, public credit, customs, and commercial matters. This was followed by proposals of similar changes for Hungary; and, on 27th February following, it was decreed that their former constitutions should be restored to Hungary, Croatia, Slavonia, and Transylvania. At last-mentioned date a fundamental law was also promulgated for the representation of the empire by a Reichsrath, composed of two bodies, a house of peers and a house of deputies, and declaring the constitution and functions of each. It was declared to be the earnest wish of the Government that hyper-centralisation should be avoided. On 1st May the new Reichsrath was formally opened by the emperor at Vienna, when he declared his conviction "that liberal institutions, with the conscientious

introduction and maintenance of the principles of equal rights of all the nationalities of his empire, of the equality of all his subjects in the eye of the law, and of the participation of the representatives of the people in the legislation, would lead to a salutary transformation of the whole monarchy." Hungary, Croatia, Slavonia, and Transylvania declined to send representatives, claiming to have constitutions and rights distinct from the empire. The Reichsrath sat till the close of 1862, occupying itself chiefly with ecclesiastical affairs, the state of education, personal liberty, and the laws relating to the press, commerce, feudal tenures, &c. In 1863 the emperor of Austria invited the different potentates of Germany to meet him at Frankfort, in order to determine upon a scheme of reform for their common country. They almost all responded to the invitation except the king of Prussia, and the congress was opened (August 16) by a speech from the emperor. The proceedings, however, did not result in any important change, owing in great measure to the want of sympathy from Prussia.

The death of Ferdinand VII., king of Denmark (15th November 1863), gave rise to a general ferment in Germany on the subject of the duchies Schleswig, Holstein, and Lauenburg. To the Germans a united fatherland had long been a favourite idea, and they now saw a step towards its accomplishment. Notwithstanding the treaty of London (8th May 1852), which fixed the succession to the Danish crown, and was signed by Austria and Prussia, they denied the right of the new king, Christian IX., to the duchies, and laid claim to them as part of Germany. To enforce their claim the diet determined that they should be occupied by an armed force, and Saxony and Hanover were directed to enter and take possession of Holstein. This was done without their coming into hostile collision with the Danish troops, who retired to Schleswig (December 1863). Soon after this, however, Austria and Prussia gave notice that they, as the chief powers in Germany, intended to take upon themselves the carrying on of the war. Hostilities commenced (1st February 1864) when Austrian and Prussian troops crossed the Schleswig frontier. Denmark had trusted to England and France coming forward to maintain the conditions of the treaty of 1852; but these powers remained passive, and the Danes, after a short but heroic stand, were forced to succumb. An armistice was concluded (1st August), and a treaty of peace was eventually signed at Vienna (30th October), by which Denmark made over Schleswig, Holstein, and Lauenburg to Austria and Prussia.

But Austria speedily suffered terrible retribution for the part she had taken in this affair. By inducing Austria to join with her, Prussia succeeded in removing part of the odium of the proceeding from herself, and she also succeeded in obtaining the aid of a rival power to secure territories which she had previously determined to appropriate as her own. The acquired territory naturally lay very convenient for Prussia, and Austria would have willingly enough given up her claim on it if Prussia had agreed to grant her a territorial equivalent in some other quarter of her dominions. This the latter power declined to do, but would readily have consented to a pecuniary compensation. A convention was therefore held at Gastein (August 1865), which brought about a temporary understanding. Prussia was to receive Lauenburg on payment of a sum of 1,500,000 thalers, while Austria was to have the administration of affairs in Holstein, and Prussia in Schleswig. Austria, however, was desirous of the formation of the duchies into a separate state, and supported the claims of the duke of Angustenburg to them. This was strenuously opposed by Prussia, who regarded the public meetings that were permitted to be held in Holstein in support of this as a breach of agreement. Austria referred

the question to the Frankfort diet, which decided in favour of the duke. Matters were now approaching a crisis. Prussia had long looked with jealousy upon the power of Austria, and considered a war with that country for the supremacy of Germany as sooner or later a necessity. The German people had for some time felt that there was not room for two great powers,—each too great to submit to the other,—one or other must give way before the country could obtain its proper place and influence in Europe. While both powers were professing the utmost desire for peace, each was actively preparing for war. Prussia entered into an alliance with Victor Emmanuel (27th March 1866), the latter undertaking to declare war against Austria as soon as Prussia commenced hostilities, while the former engaged to secure Venetia for her Italian ally. In the beginning of May orders were issued by the emperor of Austria for putting the whole army upon a war footing, and for concentrating a portion of it upon the Bohemian and Silesian frontiers; and about the same time the Prussian cabinet issued orders to fill up to the war strength the different branches of the service. On 7th June the Prussian troops entered Holstein, and compelled the Austrians to retire, which they did without bloodshed.

Austria was in an unprepared state when the war actually broke out, but the Prussian forces, on the other hand, were thoroughly equipped. The Austrian army in the north amounted to 247,000 men, besides the Saxon army at Dresden of 24,000, in all 271,000. The Prussian force consisted of three armies: the first, under the command of Prince Frederick Charles, consisted of 93,000 men, and was destined for Saxony and Bohemia; the second, under the crown prince, numbered 115,000 men, and was to operate in Silesia; while the third, or army of the Elbe, under General Herwarth, consisting of 46,000 men, was to march on the right flank of the first army, making in all 254,000 men, besides reserve corps of 24,800 men stationed at Berlin. General Benedek was appointed commander-in-chief of the Austrian army, and his forces were distributed along the frontier that separates Moravia from Saxony and Silesia. On the 16th of June the Prussians entered Saxony, and marched upon Dresden, the Saxon army retiring to join the Austrians. On the 18th the Austrians entered Silesia, and the same day the Prussians took possession of Dresden. The three Prussian armies now advanced into Bohemia, and endeavoured to concentrate in the direction of Gitschin. On June 26th an engagement took place between some companies of the first army and a body of Austrians at Podol, in which the latter were defeated, while, at Hühnerwasser, the advanced guard of the Elbe army attacked some Austrian troops and drove them back towards Münchengrätz. Here, on the 28th, a severe struggle took place between the Prussians and the Austrians, supported by the Saxons, but the latter were ultimately driven back in the direction of Gitschin. In the meantime the second army, under the crown prince, had to march through the long and narrow passes of the mountains lying between Silesia and Bohemia. On the 27th one of the corps of this army, under General Steinmetz, engaged an Austrian force under General Ramming, and after a severe contest began to give way, but the crown prince coming up, the Austrians were driven back. The same day another corps of this army took possession of Trautshau, but were attacked by the Austrians under General Gablenz, and sustained a repulse. Both sides having received reinforcements, the action was renewed next day at Soor, when victory ultimately declared for the Prussians. At Skalitz, on the 28th, the Prussians, under Steinmetz, were attacked by the Austrians under Archduke Leopold, but the latter were defeated, and the town taken by storm. It is said that on this occasion the archduke

had disobeyed positive orders, which were on no account to make an attack. On the 29th, two divisions of the first army, under Generals Tümpling and Werder, defeated the Austrians under Count Clam Gallas, at Gitschin, and took the town. The count, who occupied a strong position here, had orders not to attack the enemy, but these he had disobeyed, and the consequence was that Benedek, who had taken up a strong position at Dubenetz to oppose the army of the crown prince, found himself at once in a most dangerous situation, and was obliged to retreat towards Königgrätz. On the same day bodies of Austrians were defeated at Königinhof and Schweinschädel. In these various engagements the Austrians lost in all from 30,000 to 40,000 men. Both sides now concentrated their forces in the direction of Königgrätz, and prepared for a general engagement. On June 30 the king of Prussia joined the army, and the battle of Königgrätz, or Sadowa, was fought on the 3d of July. The Austrians numbered about 220,000, and the Prussians probably about 240,000. The battle was long and well contested, both sides fighting with the greatest determination and bravery; but at length the Austrians were broken, and obliged to retire. The Prussians lost 359 officers and 8794 men, while the Austrians and Saxons lost in all about 44,200 men, of whom 19,800 were prisoners. This terminated what has been sometimes called the *Seven Days' War*. The Austrians retreated to Zwittau and afterwards to Olmütz. A portion of the Prussians went in pursuit, but the king, with an army of upwards of 100,000 men, marched on towards Vienna, and reached Nikolsburg, July 18. After the battle of Königgrätz, the emperor, seeing the disastrous state of his affairs, resolved to cede Venetia to the Emperor Napoleon, so as to be able to bring his army in Italy against the Prussians, and he also expressed his willingness to accept the mediation of the latter to bring about a peace. The Archduke Albert, who had the command of the army in Italy, with which he had inflicted a severe defeat on the Italians at Custozza, was recalled to take the chief command in place of Benedek. An armistice, however, was agreed upon through the mediation of France (22d July). The preliminaries of peace were signed at Nikolsburg (26th July), and negotiations were afterwards carried on at Prague, where a treaty was signed (23d August). By this treaty Austria gave up to the kingdom of Italy Venetia and the fortresses of the quadrilateral, namely, Peschiera, Mantua, Verona, and Legnano; recognised the dissolution of the late German Confederation, and consented to a new formation of Germany; in which she should have no part; gave up all claim to the duchies of Holstein and Schleswig; and agreed to pay a war indemnity of 40,000,000 thalers, less 20,000,000 allowed her on account of the duchies.

Having thus obtained peace, the emperor now turned his attention to home affairs. Hungary was still in a very troubled and dissatisfied state. We have seen that she declined to send representatives to the Reichsrath, insisting on her right to self-government, and refusing to have anything else. The plan of opposition she adopted was that of passive resistance, by the non-payment of taxes. At length, at the opening of the Hungarian diet at Pesth by the emperor in person, on December 14, 1865, he recognised the necessity of self-government for Hungary so far as it did not affect the unity of the empire and the position of Austria as a great European power. He also recognised the Pragmatic Sanction as the basis on which a settlement of their difficulties was to be sought. At the opening of the diet on 19th November 1866, an imperial rescript, signed by the emperor, was read, in which he promised, by the appointment of a responsible ministry and the restoration of municipal self-government, to do justice to the constitutional demands of the Hungarians. In the end of



1866, Baron Beust, who had previously been prime minister of Saxony, and was not only a foreigner but a Protestant, was made foreign minister. He subsequently became prime minister and chancellor of the empire. In the spring of 1867 the emperor summoned the Reichsrath to assemble at Vienna to deliberate upon various important measures,—the proposed amendments in the Hungarian constitution, the question of ministerial responsibility, the sending of delegates to assemblies, the extension of the constitutional self-government of the different provinces, the reorganisation of the army, the improvement of the administration of justice, and the promotion of the economical interests of the country. It was opened by the emperor in person on May 22, and in his speech on the occasion he earnestly recommended to their attention these subjects. "To-day," he said, "we are about to establish a work of peace and of concord. Let us throw a veil of forgetfulness over the immediate past, which has inflicted deep wounds upon the empire. Let us lay to heart the lessons which it leaves behind, but let us derive with unshaken courage new strength, and the resolve to secure to the empire peace and power." On 8th June the emperor and empress were crowned king and queen of Hungary at Pesth amid great public rejoicings, on which occasion full pardon was given for all past political offences, and full liberty to all offenders residing in foreign countries to return. Many important and liberal measures were discussed and carried in the Reichsrath; in particular, marriage was made a civil contract, and the perfect equality of believers of different creeds was recognised. On 25th May 1868, the civil marriage bill received imperial assent, and on 30th July 1870 the concordat with Rome was declared to be suspended in consequence of the promulgation of the doctrine of Papal infallibility. This last measure introduced a very beneficial change in the relations between Austria and the kingdom of Italy, and has brought about more sympathy and cordiality between these two states than formerly existed.

For some years the Government had much difficulty in settling the law of elections so as to secure the due repre-

sentation of the different races and classes of the people in the Reichsrath. On 6th March 1873 a reform bill was passed by the lower house, taking the election of members of the Reichsrath out of the hands of the provincial diets and transferring it to the body of the electors in the several provinces, thus substituting direct for indirect election. In April it passed the upper house and received the imperial assent. This measure was hailed with great satisfaction, and has established the government upon a much broader and more secure basis. The session of the new Reichsrath was opened by the emperor in person on November 5. In the same year a great exhibition of the industries of all nations was held at Vienna. It was opened on May 1 by the emperor, and attracted to the capital, among others, the prince of Wales, the czar of Russia, the emperor and empress of Germany, the king of Italy, and the shah of Persia. On 2d December the twenty-fifth anniversary of the emperor's accession to the throne was celebrated amid great rejoicings in Vienna, having been celebrated three days before in Pesth. - The emperor and empress were present on both occasions, and everywhere met with an enthusiastic reception. In the spring of 1874 a bill for the abolition of the concordat was introduced by the Government, and measures for restricting the powers of the clergy passed both houses. In his speech at the opening of the Reichsrath on 5th November of that year, the emperor said that by the system of direct popular elections the empire had obtained real independence, and exhorted the members to work with united energy at the solution of the greatest of their tasks, the uniting of the people of Austria, so that she might become a powerful state, strong in ideas of justice and liberty.

See Dr F. Kohlrausch, *Die Deutsche Geschichte*, 1866; Ungewitter, *Die Oesterreichische Monarchie*, 1856; *Geschichte der Oesterreichischen Kaiserstaaten*, 1859; Stein, *Handbuch der Geographie*, 1870; Grant Duff, *Studies in European Politics*, 1866, and *Elgin Speeches*, 1871; Sir A. Malet, *The Overthrow of the Germanic Confederation*, 1870; *The Campaign of 1866 in Germany*, translated by Colonel Ven Wright, 1872; Steinhauser, *Geographie von Oesterreich-Ungarn*, 1872; *The Armed Strength of Austria*, by Captain W. S. Cooke, 1874. (D. K.)

AUTOCHTHONES, in *Greek Mythology*, the first human beings who appeared in the world, and who, as their name implies, were believed to have sprung from the earth itself. Instead of one pair as the first parents of the whole race, each district of Greece had its own autochthones, who, according to the prominent physical features of the neighbourhood, were supposed to have been produced from trees, rocks, or marshy places, the most peculiar, and apparently the most widely-spread belief being that which traced the origin of mankind to the otherwise unproductive rocks. Whether the first appearance of mankind was regarded as having been simultaneous in the various districts or not, at what time or times such appearance was made with reference, for example, to the origin of the gods who also had sprung from the earth (Pindar, *Nem.* vi. 1; Hesiod, *Works and Days*, 108), and whether the first men possessed the full human form, are questions which there is no material to answer satisfactorily. On the last point it is to be observed that Eryaichthon at Athens was said to have had legs in the form of serpents, and that this is taken to denote his origin from a marshy place. Similarly the earth-born giants, who made war against the gods, had legs in the form of serpents. In Thebes, the race of Sparti were believed to have sprung from a field sown with dragons' teeth. The Phrygian Corybantes had been forced out of the hill-side like trees by Rhea, the great mother, and hence were called *δενδροβάντες*. But whatever the primitive form of men was believed to have been, it is clear

from Æschylus (*Prometheus*, 447, *fol.*) that they were supposed to have at first lived like animals in caves and woods, till by the help of the gods and heroes they were raised to a stage of civilisation. The practice of describing legendary heroes and men of ancient lineage as "earth-born," *γηνναίς*, strengthened greatly the doctrine of autochthony, and nowhere so much as in Attica.

AUTO-DA-FE (*Act of Faith*), a public solemnity of the Inquisition in Spain and Portugal, at which the sentences of the court were read; those who were declared innocent were formally absolved, and the condemned were handed over to the secular power for punishment. The day chosen was usually some Sunday between Trinity and Advent. The first auto-da-fe was held by Torquemada at Seville in 1481; the last was probably that mentioned by Llorente, the historian of the Inquisition, as having been celebrated in Mexico in 1815. See INQUISITION.

AUTOGRAPH (*αὐτός* and *γράφω*), that which is written with a person's own hand, an original manuscript as opposed to an *apograph* or copy, is used to designate either a whole document (e.g., a letter) or a signature only. The latter is perhaps the more common use of the term. The interest attaching to the possession of autographs of distinguished men, which has created a new branch of industry, is partly historical, partly psychological. The signatures or original manuscripts are interesting and valuable elements in the representation of the life of any individual; and it has been thought that from the

autograph some conclusions might be drawn as to the mental characteristics of the writer. It is doubtless true that temperament will in some degree affect handwriting, but the conditions to be taken into account are so numerous and variable that the attempt to infer the one from the other seems practically hopeless. Poe, in his ingenious "Chapter on Autography" (*Works*, Ed. Ingram, vol. iv.), speaks very strongly on this subject. He thinks that none but the unreflecting can deny "that a strong analogy does generally and naturally exist between every man's chirography and character," and to support his statement compares the signatures and mental characteristics of a large number of contemporary American writers. In many cases, however, he is obliged to confess that no inference whatever can be drawn, in some others the analogy is extremely forced, and in others, again, the knowledge of the writer's character has evidently furnished the key for the interpretation of the handwriting. The value placed by an amateur on any autograph will, of course, vary with the celebrity of its author and the scarcity of genuine specimens. The taste for collecting autographs is not confined to modern times; many large collections, e.g., those of Loménie de Brienne, of Lacroix du Maine, and others, were formed in the 16th century, and during the same period we know that albums used to be carried about for the purpose of obtaining the signatures of famous personages. One of these albums preserved in the British Museum is of date 1578. There are at present many valuable public and private collections, while state papers and archives, of course, contain a rich harvest of royal and noble signatures. Fac-similes of original manuscripts appear first to have been printed in Forbes's *Full View of the Public Transactions in the Reign of Queen Elizabeth*, 1740-41; and soon after, several were given in Fenn's *Original Letters from the Archives of the Paston Family*, 1787.

The following are, perhaps, the most useful works on the subject:—J. G. Nichol's *Autographs of Royal, Noble, Learned, and Remarkable Personages conspicuous in English History, from the Reign of Richard II. to that of Charles II.*, Lond. 1829; *Autographic Mirror*, 1864, sqq.; Nethercliff, *Handbook of Autographs*; Phillips and Nethercliff, *Autographic Album*; Simms, *Autographic Souvenir*; Nethercliff and Simms, *Autographic Miscellany*; *Iconographie des Hommes Célèbres*, 4 vols. 1829-48; *Iconographie des Contemporains*, 2 vols. 1823-33; Feuilleat de Comches, *Casseries d'un Curieux*, 3 vols. 1849-64; Lescura, *Les Autographes*, 1865; Günther und Schulz, *Handbuch für Autographensammler*, 1856; *Sammlung historisch berühmter Autographen*, 1846; *Autographen Album zur 200. Jahrs-Gedächtnisfeier des Westphälischen Friedensschlusses*, 1848.

**AUTOLYCUS** of **PIITANE**, in **Eolis**, was one of the earliest Greek writers on mathematics and astronomy. As he is said to have given instruction to Arcesilaus, he probably flourished about the middle of the 4th century B.C. His extant works consist of two treatises; the one, *περὶ κινήσεως σφαιρῶν*, contains some simple propositions on the motion of the sphere, the other, *περὶ ἐπιπέδων καὶ κύβων*, in two books, discusses the rising and setting of the fixed stars. Neither treatise is of much scientific value. There are several Latin versions of Autolycus, and a French translation by Forcadel, 1872.

**AUTOMATON** (from *αὐτός*, self, and *μαίω*, to seize), a self-moving machine, or one in which the principle of motion is contained within the mechanism itself. According to this description, clocks, watches, and all machines of a similar kind, are automata, but the word is generally applied to contrivances which simulate for a time the motions of animal life. If the human figure and actions be represented, the automaton has sometimes been called specially an *androïdes*. We have very early notices of the construction of automata, e.g., the tripods of Vulcan, and the moving figures of Dædalus. 400 years B.C. Archytas of Tarentum is said to have made a wooden pigeon that could fly; and during the Middle Ages numerous instances of

the construction of automata are recorded. Regiomontanus is said to have made an iron fly, which would flutter round the room and return to his hand, and also an eagle, which flew before the Emperor Maximilian when he was entering Nuremberg. Roger Bacon is said to have forged a brazen head which spoke, and Albertus Magnus to have had an androïdes, which acted as doorkeeper, and was broken to pieces by Aquinas. Of these, as of some later instances, e.g., the figure constructed by Descartes and the automata exhibited by Dr Camus, not much is accurately known. But in the 18th century, Vaucanson, the celebrated mechanician, exhibited three admirable figures,—the flute-player, the tambourine-player, and the duck, which was capable of eating, drinking, and imitating exactly the natural voice of that fowl. The means by which these results had been produced were clearly seen, and a great impulse was given to the construction of similar figures. Knaeus exhibited at Vienna an automaton which wrote; a father and son named Dror constructed several ingenious mechanical figures which wrote and played music; Kaufmann and Maelzel made automatic trumpeters who could play several marches. The Swiss have always been celebrated for their mechanical ingenuity, and they construct most of the curious toys, such as flying and singing birds, which are frequently met with in industrial exhibitions. The greatest difficulty has generally been experienced in devising any mechanism which shall successfully simulate the human voice. No attempt has been thoroughly successful, though many have been made. The figure exhibited by Fabermann of Vienna is, perhaps, as yet the best. No notice of automata can be complete without at least a reference to Kempelen's famous chess player, which for many years astonished and puzzled Europe. This figure, however, was no true automaton, although the mechanical contrivances for concealing the real performer and giving effect to his desired movements were exceedingly ingenious.

**AUTUN**, the capital of an arrondissement of the same name in the department of Saône and Loire, in France, is picturesquely situated on the declivity of a hill, at the foot of which flows the Arroux. It is one of the most ancient towns of France; and when Cæsar invaded Gaul it was the most important of the *Ædii*. Its name was then Bibracte, but being afterwards much improved and embellished by Augustus it took that of Augustodunum. In the later days of the Roman empire it was a flourishing city, and consequently attracted the barbarian bands. It was successively plundered and burned by the Vandals in 406, the Burgundians in 414, the Huns in 451, the Franks in 534, the Saracens in 739, and the Normans in 895. It was burned by the English in 1379, and besieged in 1591 by D'Aumont. Yet in spite of all these disastrous events, its former greatness is attested by many Roman and other remains, among which are large masses of its ancient walls, two gates in admirable preservation, called the *Porte d'Arroux* and the *Porte Saint-André*, the walls of the so-called temple of Janus, and a pyramid in the neighbouring village of Couard, in which some recognise a monument to Divitiacus. The cathedral is a structure of the 11th and 12th centuries, and is surmounted by a remarkable spire of the 16th. Autun is the seat of a bishopric, and has a college, a diocesan seminary, a museum, which is very rich in medals and other minor antiquities, a library, a theatre, &c., with tribunals of primary jurisdiction and commerce. It has manufactures of cotton goods, hosiery, carpets, leather, and paper, with a considerable trade in timber, hemp, and cattle. Population in 1872, 11,684.

**AUVERGNE**, a district, and formerly a province, of France, corresponding to the departments of Cantal and Puy-de-Dôme, with the arrondissement of Brioude in Haute-Loire. It is divided into Lower and Upper by the River

Buc; the distinction between the two portions being well marked by their physical features. Upper Auvergne is rugged and mountainous, and is covered with evidences of volcanic activity, while Lower Auvergne consists largely of fertile and well-watered expanses. In climate, too, there is a marked difference; the former suffering from violent extremes, and the latter enjoying a mild and equable temperature. The whole district is largely agricultural, and special attention is paid to the rearing of cattle, horses, and mules. The mountains are rich in minerals, such as iron, lead, copper, and coal; and numerous medicinal springs are scattered along their slopes. The inhabitants, who to a certain extent are the descendants of the ancient *Auverni*, are a strong, ungainly race, habituated to toilsome labour. For a long time they have been accustomed to leave their homes for the purpose of seeking their fortunes abroad, returning after they have acquired a competency. Spain was at one period a favourite resort, but the current of emigration is now principally towards Paris or the Belgian towns. In Paris alone it has been calculated that the *Auvergnats* number 50,000. They speak a distinct dialect, and are also recognised by their pronunciation. A closer resemblance to Latin, and the presence of many sounds, such as *ts*, *tz*, *dj*, which are foreign to ordinary French, are among the most striking features of the *patois*; the vocabulary also contains words introduced by the English at the time of their occupation of the country in the 14th century. Of the existing literature a considerable proportion is spurious. Auvergne was early raised to the rank of a countship, and passed into the hands of various families, the most important of which is known as *Le Tour d'Auvergne*. It was finally united to the crown by Louis XIII.

Of the numerous books which have been written on this interesting province, the following may be mentioned:—Aigueperse, *Petit Dict. des personnages d'Auvergne*, 1850; Michel, *L'ancienne Auvergne*, 3 vols. fol.; Imberdis, *L'Auvergne historique*, and *Hist. des guerres raïg. en Auvergne pendant les XVI<sup>e</sup> et XVII<sup>e</sup> siècles*; Allard, *Les usines thermo-minérales d'Auvergne*.

**AUXENTIUS** of CAPPADOCIA was an Arian theologian of some eminence. When Constantine deposed the orthodox bishops who resisted, Auxentius was installed into the seat of Dionysius, bishop of Milan, and came to be regarded as the great opponent of the Nicene doctrine in the West. So prominent did he become, that he was specially mentioned by name in the condemnatory decree of the synod which Damasus, bishop of Rome, convened in defence of the Nicene doctrine. When the orthodox emperor Valentinian ascended the throne, Auxentius was left undisturbed in his diocese, but his theological doctrines were publicly attacked by Hilarius of Poitiers. The chief source of information about him is the *Liber contra Auxentium* in the Benedictine edition of the works of Hilarius.

**AUXERRE** (the ancient *Auxeriodurum*), a town of France, in the department of Yonne, situated on the banks of the Yonne, in a wine-producing district, and built in an antique fashion: Its cathedral is one of the finest Gothic buildings in the country, and its episcopal palace, now used as a prefecture, will bear comparison with any. It has several normal schools, a college founded by the famous Jacques Amyot (who was a native of the town, and died there in 1593), a society of agriculture, hotanic garden, museum, theatre, an extensive and valuable library, &c. The Yonne is navigable from a little above the town. Besides trade in wine and in firewood, there are manufactures of cloths, druggets, serges, cotton and woollen stockings, and some considerable tanneries. Population, 15,497.

**AUXONNE** (formerly *Asonium*, i.e., *ad Sonam*, from its position on the Saône), a city of France, in the arrondissement of Dijon and department of Côte d'Or. It is

strongly fortified, and possesses an old castle, an arsenal, and a school of artillery. Besides their manufactures of cloth and serges, the inhabitants carry on by the river considerable traffic with Lyons in wine, grain, and wood. Long. 5° 24' E., lat. 47° 13' N. Population, 5911.

**AVA**, the former capital of the Burman empire, lies in 21° 53' N. lat., and 96° 1' E. long. It is situated on the Irawadi, which is here 3282 feet broad, and which, making a bend out of its ordinary course, flows past the city on the north. On the east it has the river Myt-nge, a rapid stream 450 feet broad, which flows into the Irawadi close under its walls. From this river a canal has been dug, through which its waters flow on the south-east angle of the city, and are again brought into the same river. On the south flows the deep and rapid torrent of the Myt-tha, an offshoot of the Myt-nge, which, falling into the Irawadi, forms the defence both of the south and of the west face of the town. It is divided into the upper and lower, or the lesser and the larger town, both of which are fortified.

The brick wall that surrounds the city is 15½ feet in height and 10 feet in thickness, on the inside of which is thrown up a bank of earth, forming an angle of 45 degrees. There is a ditch round the outer wall which is inconsiderable, and in the dry season fordable in every part. The lesser town is chiefly occupied by the royal palace, the hall of justice, the council chamber, the arsenal, and the habitations of a few courtiers of distinction. A strong well-built wall of more solid construction than the outer wall of the city, and about 20 feet high, encloses the square in which these buildings are situated, and on the outside is a teak-wood stockade of the same height. The ditch which surrounds the lesser town is, moreover, deeper and broader than that of the city, and when full is not to be forded. There are, however, three causeways across, which communicate with the adjacent country. The circumference of the city, excluding the suburbs, is about 5½ miles, but over this extensive area the houses are but thinly scattered; some quarters are, indeed, wholly destitute of habitations, and have the appearance merely of neglected commons. In general the dwellings of the inhabitants are of the most miserable sort, being mere huts thatched with grass. Wretched as are such habitations to European eyes, the poorer classes are perhaps as well lodged here as in any other parts of Asia. Their sleeping-places are elevated 2 or 3 feet from the ground. Some of the houses of the chiefs are constructed of planks, and tiled; but there are not, according to Mr Crawford, more than half-a-dozen edifices built of brick and mortar. Ava, like all the other Burmese towns, is adorned with numerous temples, of which the gilded spires, rising aloft, present on a distant view of the place a splendid and imposing appearance, which is far from being realised on a nearer inspection. The largest of these temples contains two distinct edifices, one in the ancient, the other in a modern form; the former containing an image of Ganesha, not of marble, as Byles supposes, but of sandstone. It is in a sitting posture, and is 24 feet in height. The head is 8 feet in diameter. There is another very large temple, and a third named the "Beautiful." The one called Maong-Batna is of great celebrity; it is the one in which the public officers of the government take, with the most solemn forms, the oath of allegiance. The temple called Maha-mrat-muni had an addition made to it some years ago, of which Mr Crawford mentions that the numerous and richly-gilded pillars and splendid ceiling exceeded anything that was to be seen without the palace. Ava contains eleven markets or *béira*, composed of thatched huts and sheds, which, however, are well supplied with all that is necessary for the wants of the people. Besides native commodities, there are exposed in these markets the produce of China and Lao, with British cottons, woollens, glass, and earthenware. The Burman monasteries are mostly built of wood; and of those composed of more solid materials, a few ancient ones are nearly all that are to be seen. The only exception is a monastery, built some years ago by the queen, adjoining the palace—an unshapely fabric of immense size, but a very conspicuous object.

This former capital of the Burman dominions comprehends, according to the political divisions of that empire, the town of Sagaing, on the opposite shore of the Irawadi, and the town of Amarapura, 4 miles to the east. The town of Sagaing extends along the Irawadi for more than a mile and a half, but is of inconsiderable breadth. It consists of mean houses thinly scattered among gardens and orchards, the principal trees in the latter consisting of fine old tamarinds. Over the site of the town and its environs are scattered innumerable temples, some of them

old and ruinous, others modern. On the river face it has a brick wall about 10 feet in height, with parapet and embrasures like that of Ava, and extending for above half a mile along the river. Amarapura is a large place, and was formerly the capital; but Ava, which was twice before the capital, was again made so in 1822. It continued to be so till 1853, when the present king, on his accession, transferred the capital to Mandalay. To each of the towns of Ava, Sagaing, and Amarapura, are attached districts, the two former of which extend 12 miles along the river, and are of equal breadth. The district of Amarapura is of equal size, so that Ava must be considered as not only the name of the former capital, but of a large district, which includes an area of 288 miles, containing, according to the most accurate estimate, 354,200 inhabitants; but the city of Ava is not supposed to contain more than 50,000 inhabitants, and, according to Mr Crawford, half that number would be nearer the truth. The place, taken altogether, affords few indications of industry or commercial enterprise.

**AVALLON**, a town of France, in the department of Yonne, finely situated on a granite rock, at the foot of which flows the river Voisin or Cousin. The church of St Lazare, which dates from the 12th century, is a good specimen of Burgundian Gothic. Manufactures of cloth, hats, hosiery, leather, and paper are carried on, and there is a considerable traffic in firewood, which is conveyed by the Voisin, the Yonne, and the Seine to Paris. The town was long an object of dispute between Burgundy and France, but was finally united to the crown on the death of Charles the Bold. It was pillaged by the Leaguers in 1594. Population, 6070. Long.  $3^{\circ} 58' E$ , lat.  $47^{\circ} 30' N$ .

**AVATCHA**, one of the numerous volcanoes of Kamchatka, in lat.  $53^{\circ} 17' N$ , and long.  $158^{\circ} 50' E$ . It rises to a height of nearly 9000 feet (Mr Kennan says 11,000), and has an extensive crater at the summit and another on its side. It was in active eruption in 1827, 1837, and 1855. About twenty miles to the south lies the village of Avatcha on a river of the same name; and in the immediate neighbourhood of the mountain is situated the little town of Petropavlovski, which contains memorials of Behring and La Ferouse, and was the scene of a desperate conflict during the Crimean War between the Russians and an invading party of the allies.

**AVEBURY**, a village of England, in the county of Wilts, 6 miles W. of Marlborough. It occupies the site of

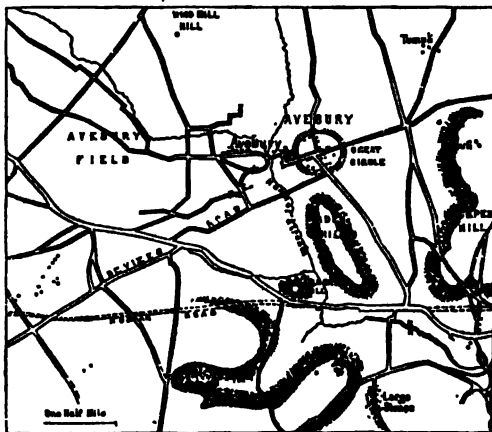

Plan of Avebury.

one of the most remarkable megalithic structures in England. This consisted of a large outer circle formed of

100 stones of from 15 to 17 feet in height, and about 40 feet in circumference, enclosing an area of about 1000 feet in diameter. This circle was surrounded by a broad ditch and lofty rampart. Within its area were two smaller circles, 350 and 325 feet in diameter respectively, each consisting of a double concentric row of stones,—a stone pillar or maenhir, 20 feet high, occupying the centre of the one, and a cromlech or dolmen that of the other. A long avenue of approach, now known as the Kennet Avenue, consisting of a double row of stones, branched off from this structure towards the S.E. for a distance of 1430 yards. Few traces of this immense erection now remain—the stones having been broken down and used in the construction of the houses of the village, and for other purposes. In the vicinity are two other monuments of great importance, which may be regarded as belonging to the same group, namely, the double oval of megaliths on Halkpen Hill—Hace's pen—and the artificial mound known as Silbury Hill. The Halkpen oval was, according to Stukeley, 138 feet by 155, and had an avenue 45 feet wide stretching in the direction of Silbury Hill. This hill is due south from Avebury, and the distance from the centre of the circle to the centre of the mound is very nearly one Roman mile. Much discussion has taken place about the age and object of these constructions, the most popular theory hitherto being that which ascribed them to the Druids, and thus got rid of historic difficulties by escaping into the region of the prehistoric. Recently, Mr Ferguson has strenuously maintained that the larger circle, or Avebury proper, and Silbury Hill, commemorate the last of the twelve Arthurian battles, which was fought (520 A.D.) at Badon Hill, a name which he identifies with Waden Hill.

**AVEIRO**, a town of Portugal, province of Beira, the seat of a bishopric and college. It has sardine, oyster, and herring fisheries, as well as a thriving trade in oil, salt, wine, and oranges. The haven is wide and deep. Population, 6456. Long.  $8^{\circ} 34' W$ , lat.  $40^{\circ} 40' N$ .

**AVELLA**, a town of Italy, in the province of Principato Ulteriore, in a fine situation, and commanding most extensive prospects. It is distant about 30 miles from Naples, and contains 3714 inhabitants. Near it are the remains of the ancient Abella.

**AVELLINO**, a fortified city of Italy, in the province of Principato Ulteriore, at the foot of Mount Vergine, and 28 miles E. of Naples. It is the see of a bishop, and has a cathedral, several parish churches, a royal college, &c., with manufactories of cloth, paper, macaroni, and sausages, and extensive dye-works. It has a considerable trade in corn, chestnuts, and hazel-nuts. The city has at various times suffered severely from earthquakes. Population, 20,492.

**AVEMPACE**. **ABU BEKR MOHAMMED IBN JAHYA**, surnamed Ibn Bedja or Ibn Sayeg (i.e., son of the goldsmith), whose name has been corrupted by the Latins into Avempace, Avenpace, or Aban Pace, was the earliest and one of the most distinguished of the Arab philosophers in Spain. Almost nothing is known of the events in his life; he was born, probably at Saragossa, towards the close of the 11th century, and died at Fes in 1138 at a not very advanced age. Like most of the Arab philosophers, he was a physician by profession, and he is also said to have been a man of wide general culture. He was a skilled musician, mathematician, astronomer, and poet, and though he is now known only through his metaphysical speculations, these do not seem to have been his favourite studies. His writings, if we accept the report of Oecibia, were varied and numerous. Several treatises on logical subjects are mentioned by Casiri as still among the MSS. at the Escorial, and some smaller pieces are also found in other

libraries. The most important of his works is that noticed by Averroes, who promised a complete discussion of it, but unfortunately neither the treatise nor the exposition has come down to us. Our knowledge of it is almost entirely drawn from the notices given by Moses of Narbonne, a Jewish writer of the 14th century, in his commentary on the somewhat similar work of Ibn Tofail. The title of the work may be translated as the *Régime* or *Conduct of the Solitary*, understanding by that the organised system of rules, by obedience to which the individual may rise from the mere life of the senses to the perception of pure intelligible principles, and may participate in the divine thought which sustains the world. These rules for the individual are but the image or reflex of the political organisation of the perfect or ideal state; and the man who strives to lead this life is called the *solitary*, not because he withdraws from society, but because, while in it, he remains a stranger to its ways, and guides himself by reference to a higher state, an ideal society. Avempace does not develop at any length this curious Platonic idea of the perfect state. His object is to discover the highest end of human life, and with this view he classifies the various activities of the human soul, rejects such as are material or animal, and then analyses the various spiritual forms to which the activities may be directed. He points out the graduated scale of such forms, through which the soul may rise, and shows that none are final or complete in themselves, except the pure intelligible forms, the ideas of ideas. These the intellect can grasp, and in so doing it becomes what he calls *intellectus acquisitus*, and is in a measure divine. This self-consciousness of pure reason is the highest object of human activity, and is to be attained by the speculative method. The intellect has in itself power to know ultimate truth and intelligence, and does not require a mystical illumination as Algazali taught. Avempace's principles, it is clear, lead directly to the Averroistic doctrine of the unity of intellect, but the obscurity and incompleteness of the *Régime* do not permit us to judge how far he anticipated the later thinker. (See Munk, *Mélanges de Phil. Juives et Arabes*, pp. 383-410.)

AVENBRÜGGER, or AVERNBRÜGGER, LEOPOLD, a physician of Vienna, the discoverer of the important mode of investigating diseases of the chest and abdomen by *auscultation*. His method was to apply the ear to the chest, and to note the sounds it afforded on percussion by the hand, or what is called *immediate auscultation*. His Latin treatise, *Inventum novum ex Percussione Thoracis Humani Interni Pectoris Morbos detegendi*, published in 1761, excited little attention, until it was translated and illustrated by Corvisart, in 1808, when it soon led the way to Laennec's great improvement of aiding the ear by the stethoscope, or *mediate auscultation*. The great value of the method introduced by Avenbrugger, in the diagnosis of internal diseases, is now universally acknowledged. He was born at Grätz in 1722, and died in 1809.

AVENTINUS (JOHANN THURMAYER), author of the *Annals of Bavaria*, was born in the year 1466 at Abensberg. He studied first at Ingolstadt, and afterwards in the university of Paris. In 1503 he privately taught rhetoric and poetry at Vienna, and in 1507 he publicly taught Greek at Cracow, in Poland. In 1509 he read lectures on some of Cicero's works at Ingolstadt, and in 1512 was appointed preceptor to Prince Ludwig and Prince Ernst, sons of Albert the Wise, duke of Bavaria, and travelled with the latter of these princes. After spending several years in the collection of materials he undertook to write the *Annales Boiorum*, or *Annals of Bavaria*, being encouraged by the dukes of that territory, who settled a pension upon him, and gave him hopes that they would defray the expenses of publication. He finished, but did

not publish, his work in 1528, and in the following year he was imprisoned on suspicion of heresy. He was soon released from confinement, but the indignity he had suffered seriously affected him. He died in 1534 at Ratisbon. His history, which has gained for him considerable reputation as a writer, was published, but with some important omissions, in 1554, by Ziegler, professor of poetry in the university of Ingolstadt. These passages, which were adverse to the Roman Catholics, were all restored in the edition published at Beale in 1580, by Nicholas Cisner. Besides his other writings, Geaner attributes to him a curious work, entitled *Numerandi per digitos manuales Veterum Consuetudines*.

AVENZOAR [ABU MERWAN ABDALMALIK IBN ZOHR], an eminent Arabian physician, who flourished about the end of the 11th or beginning of the 12th century, was born at Seville, where he exercised his profession with great reputation. His ancestors had been celebrated as physicians for several generations, and his son was afterwards held by the Arabians to be even more eminent in his profession than Avenzoar himself. He was contemporary with Averroes, who, according to Leo Africanus, heard his lectures and learned physic of him. This seems probable, because Averroes more than once gives Avenzoar very high and partly deserved praise, calling him admirable, glorious, the treasure of all knowledge, and the most supreme in physio from the time of Galen to his own. Avenzoar, notwithstanding, is by the generality of writers reckoned an empiric; but Dr Freund observes that this character suits him less than any other of the Arabian physicians. Avenzoar belonged, in many respects, to the *Dogmatists* or *Rational School*, rather than to the *Empirics*. He was a great admirer of Galen; and in his writings he protests emphatically against quackery and the superstitious remedies of the astrologers. He shows no inconsiderable knowledge of anatomy in his remarkable description of inflammation and abscess of the mediastinum in his own person, and its diagnosis from common pleuritis as well as from abscess and dropsy of the pericardium. In cases of obstruction or of palsy of the gullet, his three modes of treatment are ingenious. He proposes to support the strength by placing the patient in a tepid bath of nutritious liquids, that might enter by cutaneous imbibition, but does not recommend this. He speaks more favourably of the introduction of food into the stomach by a silver tube; and he strongly recommends the use of nutritive enemata. From his writings it would appear that the offices of physician, surgeon, and apothecary were already considered as distinct professions. He wrote a book entitled *The Method of Preparing Medicines and Diet*, which was translated into Hebrew in the year 1280, and thence into Latin by Paravicinus, whose version, first printed at Venice 1490, has passed through several editions.

AVERAGE, a term used in maritime commerce to signify damages or expenses resulting from the accidents of navigation. Average is either *general* or *particular*. General average arises when sacrifices have been made, or expenditures incurred, for the preservation of the ship, cargo, and freight, from some peril of the sea, or from its effects. It implies a subsequent contribution, from all the parties concerned, rateably to the values of their respective interests, to make good the loss thus occasioned. Particular average signifies the damage or partial loss happening to the ship, goods, or freight by some fortuitous or unavoidable accident. It is borne by the parties to whose property the misfortune happens, or by their insurers. The term average originally meant what is now distinguished as general average; and the expression "particular average," although not strictly accurate, came to be afterwards used for the convenience of distinguishing those damages or partial

losses for which no general contribution could be claimed.

Although nothing can be more simple than the fundamental principle of general average, that a loss incurred for the advantage of all the coadventurers should be made good by them all in equitable proportion to their stakes in the adventure, the application of this principle to the varied and complicated cases which occur in the course of maritime commerce has given rise to many diversities of usage at different periods and in different countries. It is soon discovered that the principle cannot be applied in any settled or consistent manner unless by the aid of rules of a technical and sometimes of a seemingly arbitrary character. The distinctions on which these rules turn are often very refined indeed. This is the chief reason why no real progress has yet been made towards an international system of general average, notwithstanding repeated conferences and other efforts by most competent representatives from different countries, seeking to arrive at a common understanding as a preliminary basis for such a system. A brief summary only can be given here of the rules which have been established in Great Britain by usage, or by legal decisions, in connection with the subject.

All general average losses may be divided into two principal classes—(1), *sacrifices* of part of the cargo and freight, or of part of the ship, for the general safety; (2), *extraordinary expenditures* incurred with the same object. We shall notice these in their order.

When a part of a cargo is thrown overboard (or *jettisoned*, as it is termed) to save the ship from foundering in a storm, or to float her when stranded, or to facilitate her escape from an enemy, the loss of the goods and of the freight attached to them must be made good by average contribution. But if goods jettisoned have been originally stowed on deck, no contribution can be demanded for them, unless they are so carried according to the common usage and course of trade on the voyage for which they are shipped, or with the consent of all the parties concerned in the ship and cargo.

If, instead of being thrown overboard, the goods are put into boats or lighters, and lost or damaged before reaching the shore, such loss is regarded as a virtual jettison, and gives a claim to average contribution. The same rule applies to damage occasioned by the goods being put ashore on muddy ground, or where they cannot be kept in ordinary safety. But when the goods have been conveyed to a place of ordinary safety, they cease to be at the risk of the general interest; and should they be damaged there by fire or other accidents the loss must be borne by the individual proprietors, or by their insurers.

Damage done to the cargo by discharging it at a port of refuge in the manner and under the circumstances customary at that port, is not allowed as general average. This rule covers the case of wastage, breakage, leakage, &c., from handling the goods in the ordinary course of discharging, warehousing, and reshipping.

If goods are thrown overboard from having become, through heating or other cause peculiar to their own condition, a source of special danger to the whole interest, the loss is not recoverable in general average. So, too, if a cargo is discharged at a port of refuge from damage resulting from its own *vice propre*, the costs are chargeable to its owners.

The loss of corn, salt, guano, or similar goods, arising from their being pumped up or baled out with the water in the vessel, is not recoverable by average contribution. The damage done to the cargo by means of water thrown down the hatches, or admitted into the ship by scuttling her, for the purpose of extinguishing an accidental fire, was excluded from general average by the usage of Lloyds up till 1873. In that year the courts of Queen's Bench and Exchequer Chamber expressed a strong opinion

in connection with the case of *Stewart v. the West India and Pacific Steamship Company*, that such damage ought to be made good by average contribution. The usage has now been altered accordingly.

The amount of compensation to be made for goods sacrificed by general average acts is determined by the net market price they would have produced on arrival at the port of destination had they not been sacrificed; but under deduction of the freight attaching to them (which is made good to the shipowners), and of the charges for duties and landing expenses which are saved.

The general average acts next to be considered are those which involve sacrifices of part of the *ship or her materials*.

The same principles which regulate the case of goods thrown overboard apply also to the jettison of the ship's chains, anchors, hawsers, spars, boats, or other stores. But if water-casks are stowed on deck, or if chains and hawsers are carried on deck when the vessel is not near the land so as to render it necessary that they should be so carried, the loss arising from the jettison of these articles falls on the shipowner; and if boats are jettisoned in consequence of their having been broken adrift from their fastenings on deck by the force of the sea, they are excluded from general average, and are charged to particular average on the ship. The damage done to the ship by cutting holes to effect a jettison of the cargo, or to pour down water to a fire, or by scuttling her for that purpose, is allowed as a general average charge. The damage arising from cutting or knocking away a portion of the ship's bulwarks in order to prevent the deck from being flooded in a storm, is compensated in the same manner.

When sails or masts are cut away in order to right a ship which has been thrown on her beam-ends, or to prevent her from driving on a lee-shore, the loss is made good by average contribution; but if the object in cutting away a sail or spar be merely to *save a mast*, the loss is not made good in general average.

It frequently happens that masts or yards are sprung and carried away by the force of the wind, and are left entangled in the rigging, or hanging over the ship's side in what is termed "a state of wreck;" in these circumstances it becomes necessary to cut them away, with the sails and rigging attached, and to throw the whole overboard, otherwise they would impede the navigation, and endanger the ship and cargo. On this ground it is held by some authorities that the loss caused by the act of cutting them away should be made good by average contribution. But this act is the direct consequence of the previous accident, which places these articles in a situation where it is impossible to save them without imperilling the ship, cargo, and lives. It would not be reasonable to imperil these for such a purpose; whence it follows that the displaced articles are already *virtually* lost by means of the original accident, before the loss is *actually* consummated by cutting them away. This loss is accordingly excluded, by the usage of this country, from average contribution. On the same principle, no contribution can be demanded for any articles which are sacrificed as having themselves become, through previous accident, the immediate cause of danger to the whole interest.

The loss of sails or spars, in consequence of carrying a press of canvas to avoid a lee-shore, or to escape from an enemy, is not the subject of general average in this country; neither is the damage suffered by the ship from *straining*, under any such extraordinary press of sail.

When anchors and cables are slipped from in order to work a vessel off a lee-shore, or to avoid collision with another ship, the loss is made good by average contribution; but if the cable is slipped in order that the vessel may join convoy, or because the anchor has become

hooked to some object at the bottom and cannot be raised, the loss is borne by the shipowner.

When sails, ropes, or other materials are cut up and used at sea for the purpose of stopping leaks or to rig jury-masts, or when the common benefit requires that they should be applied to some purpose for which they were not originally intended, the loss is made good in general average. The same rule applies to the case of hawsers, cables, anchors, sails, or boats, lost or damaged in attempting to force off a stranded vessel from the shore.

The damage sustained in defending a ship against a pirate or an enemy is not the subject of general average in this country; it is treated as particular average on the ship.

It has been much debated by writers on maritime law, whether the voluntary stranding of a ship, in order to prevent her from foundering, should be treated as a general or as a particular average loss. In the United States it has been settled, by judicial decision, that the loss in question constitutes a general average claim; but the opposite doctrine is acted upon in the usage of Great Britain, and the point has never been decided by the courts of law. It appears to us that the argument greatly preponderates against the rule adopted in the United States, and in favour of the usage established in this country. The only reason for regarding this loss as the subject of general average is, that it originates in the intentional act of running the ship aground, for the preservation, as far as possible, of the whole interest concerned. But it can seldom be known beforehand how the different interests at stake will be specially affected by the act in question;—whether, for instance, the damage to the cargo may not be more serious than the damage to the ship, or *vice versa*. Thus no particular part of the interest can be said to be intentionally sacrificed for the benefit of the whole; the intention, indeed, is not to sacrifice any one part, but to place the whole interest in a situation of less peril than it would otherwise have been in. What particular damages may thereafter ensue to either ship or cargo will depend, in each case, on a variety of circumstances entirely accidental in their character, and therefore in no proper sense the subject of previous intention. The same rule, therefore, which excludes from general average accidental damages in all other cases, ought to exclude them in this case also. Moreover, when the alternatives are either that the vessel be left to founder, or that she be run ashore with a chance of preservation, there can really be no room for choice, or, at all events, the elements of will and intention are entirely subordinate in the part they must play under the pressure of the existing circumstances; and in this view the stranding is as truly inevitable as if it had been caused by the force of the winds and waves alone.

But, even were these reasons less weighty than it appears they are, a serious practical objection might be urged against the doctrine that voluntary stranding should be a general average loss, on the ground that it would in most cases be impossible to distinguish between the damages received by the ship and cargo prior to the stranding, and those sustained after or in consequence of it. It is needless to remark, that before a ship can be in such imminent danger of foundering as to render it necessary to run her ashore, she must be presumed to have sustained a very considerable amount of damage; and the probability is, that the cargo also will have suffered to a corresponding extent. Up to this point these damages are confessedly particular average; and were it held that the damages after the stranding were the subject of general average, it would, of course, be necessary to distinguish the separate damages that belonged to each. But in every case these different damages would exist in varying proportions, yet always so incorporated together that justice could never

have a more perplexing task than that of discriminating between them. No general rule could be applied that would meet the widely different circumstances of each particular case; and the arbitrary method of adjustment that would alone be possible would doubtless give rise to endless dissatisfaction and dispute. On the ground of expediency, therefore, as well as on that of principle, the usage now established in this country ought to be maintained, notwithstanding the high authorities by whom the opposite practice has been countenanced.

The amount of general average losses on the ship is compensated by allowing to the owners the cost of repairs, or of new materials in place of those sacrificed, subject to the deduction of one-third for the difference of value between old and new; but no deduction is made from the cost of new anchors, and only one-sixth is deducted from the cost of new chain cables. If the ship be on her first voyage (which is held to include the homeward as well as the outward passage), the repairs and new materials are allowed in full.

We now proceed to notice the second principal class of general average losses, consisting of extraordinary expenditures incurred with a view to the common benefit.

When a ship is obliged to put into a port of refuge, in consequence of damage received in the course of the voyage, the usage in this country is to allow as general average all the charges connected with the entrance of the vessel into the port, and with the landing and warehousing of the cargo, when this is necessary to admit of the ship being repaired. Thus the expenses of pilotage or other assistance into the port, the harbour dues, and similar charges, the costs of the protest taken by the master and crew, and of the survey held to ascertain whether the cargo requires to be discharged, together with the charges for landing the cargo and conveying it to a warehouse or other place of safety, are all made good as general average. The costs of repairing the ship are charged to general average only in so far as the repairs may refer to damages which are themselves the proper subject of general contribution. If the damages are of the nature of particular average, as is more usually the case, they are charged accordingly; or if they proceed from "wear and tear," they are stated against the shipowner.

The warehouse rent for the cargo at a port of refuge, and any expenses connected with its preservation, form special charges against that particular interest, and are borne by the proprietors of the goods, or by their insurers. When goods are insured "free from particular average, unless the ship be stranded," it is necessary, if the ship has not been stranded, to distinguish the charges for warehouse rent and fire insurance from those incurred in connection with the preservation of the goods from the effects of damage,—the underwriters being liable for the former, but not for the latter.

The expenses of reshipping the cargo, and the pilotage, or other charges *outwards*, are borne by the freight. If the entire cargo cannot be taken on board again, from the want, at the port of refuge, of the usual facilities for stowing it, the loss or expenses resulting from the exclusion of part of it are not treated, in this country, as the subject of general contribution.

The wages and provisions of the master and crew during the period of detention at a port of refuge are not admitted as a charge against general average, it being held that the shipowner is bound to keep a competent crew on board the ship from the commencement to the end of the voyage at his own expense.

The charges for agency at a port of refuge are brought against the general average, even though they may have been originally made in the form of separate charges

against the ship and cargo respectively. Commissions on money advanced, maritime interest on bottomry and *respondentia*, and the loss on exchanges, &c., are apportioned relatively to the gross sums expended on behalf of the several interests concerned.

The expenses incurred in getting a stranded ship off the ground, the hire of extra hands to pump a ship which has sprung a leak, and the sums awarded for salvage or for other services rendered to the ship and cargo under any extraordinary emergencies, are compensated by average contribution. But this rule applies only to the *extraneous* assistance that may have been obtained, the crew being bound to do their utmost in the service of the ship on all occasions, with extra remuneration for what they might consider extraordinary exertions on their part.

The costs of reclaiming the ship and cargo after having been captured are allowed as general average charges; and although *ransom* to an enemy is prohibited in this country by legal enactment, it seems that this does not apply to the case of money or goods given up by way of composition to pirates for the liberation of the ship and cargo, and that this would also form a subject of average contribution.

When the ship and cargo arrive at the port of destination it is unnecessary, in ordinary cases, to distinguish, in the adjustment of the general average, between the losses which have arisen from *sacrifices* and those which have resulted from *expenditures* for the common benefit. But if the ship and cargo should be lost before reaching their destination, no contribution is due for the goods or ship's materials which may have been *sacrificed* at a former stage of the voyage, the owners of these being in no worse position than any of their coadventurers. On the other hand, it is evident that when money has been *expended* for the common benefit, the subsequent loss of the ship and cargo should not affect the right of the party who has made the advance to recover it in full from all the parties for whose advantage it was originally made. Hence, while *sacrifices* are made good only in the event of the ship and cargo being ultimately saved, *expenditures* must be reimbursed whether the ship and cargo be eventually saved or lost; and the contribution for these *expenditures* must be regulated by the values of the ship, cargo, and freight as they stood at the time when the advances were made.

If, however, the money required for average expenditures has been raised by means of bottomry, and the ship be lost before completing the voyage, there can be no claim for reimbursement,—the risk being assumed by the bottomry lender in consideration of the premium he receives on the sum advanced. When there is no bottomry, it is a usual practice, but not an invariable rule, to insure the average disbursements by a special policy. When this has been done, and when the amount has been recovered on the subsequent loss of the ship, it cannot be again claimed from the individuals who would otherwise have been liable. But if the expenditures are not insured, either by a bottomry contract, or by a special policy, and if the ship and cargo be totally lost in the subsequent course of the voyage, the parties for whose benefit the expenditures were incurred must reimburse them on the principles already explained. These parties, however, have recourse on their original insurers, not only for the total loss of the interests insured, but also for the previous expenditures, although the insurers may thus be called on to pay a *larger sum* than the amount of the insurance.

The contribution for general average losses is regulated by the values of the respective interests for the benefit of which they were incurred. The practical rule adopted, in all ordinary cases, is to estimate the ship, cargo, and freight at their *net* values to their owners, in the state in

which they arrive at the port of destination, *but including in these values the sums made good for sacrifices*, and to assess the contribution accordingly. The necessity for including the amount of compensation made for sacrifices in the valuations on which the contribution is charged, arises from the principle that all the parties interested in the adventure should bear the ultimate loss in exact proportion to their respective interests, which would not be the case if the owners of the articles sacrificed were to recover their full value without being themselves assessed for the loss thereon in the same manner as their coadventurers.

The contributory value of the *ship* is accordingly her actual value to her owner in the state in which she arrives, whether damaged or otherwise, including the sum made good in the general average for any sacrifices which may have been made of part of the ship or her materials.

The value of the *cargo* for contribution is its net market value on arrival, after deducting the charges incurred for freight, duty, and landing expenses, but without deducting the costs of insurance or commission. If goods be damaged; they contribute only according to their deteriorated value; and if special charges have been incurred on the cargo at a port of refuge (as for warehouse rent, &c.), the amount of these charges is deducted. The sum charged to general average for goods sacrificed is of course added to the valuation. All goods carried in the ship for the purposes of traffic must be included in the valuation of the cargo; but the wearing apparel, or personal effects, of the passengers and crew are exempted from contribution.

The value of the *freight* for contribution is the sum received by the shipowner on the completion of the voyage for the carriage of the cargo, after deducting from that sum the wages reckoned as from the date of the casualty, the port charges at the place of destination, and the special charges against the freight which may have been incurred at a port of refuge, consisting of the costs of reshipping the cargo, and of outward pilotage, &c. The provisions for the voyage are not deducted, as these are held to have formed part of the original value of the *ship*. If the freight has been paid in advance, it forms part of the value of the *goods*, and, consequently, does not contribute as a separate interest. When a sum has been advanced on account of freight, subject to insurance, it must be distinguished from the portion of the freight which remains at the shipowner's risk, and be charged separately for its rateable contribution; and the freight so advanced is not subject to deduction for wages, &c., this deduction being made only from the freight at risk. It has been decided that, when a vessel has been originally chartered for a double voyage, the whole freight to be earned under the charter-party must contribute at its net value, after deducting the wages and other charges which must be incurred in earning it. The effect of this rule is to render the freight attaching to the *return* voyage, as well as that attaching to the voyage *outwards*, liable to contribute for average losses arising in the course of the outward passage,—a result the equity of which is not always very apparent.

An adjustment of general average made at any foreign port where the voyage may terminate, if proved to be in conformity with the law and usage of the country to which such foreign port belongs, is binding on all the parties interested as coadventurers, although they may be subjects of this country, and although the adjustment may be made on principles different from those sanctioned by the laws or usages of Britain. The reason for this rule is, that the parties engaging in the adventure are held to assent to the known maritime usage according to which general average is adjusted on the arrival of the ship and goods at the port of destination.



The subject of general average is only incidentally connected with that of marine insurance, being itself a distinct branch of maritime law. But the subject of particular average arises directly out of the contract of insurance, and will therefore be best considered in connection with it. (See *INSURANCE*.)

For further information with respect to the subject of average, the reader is referred to the famous work of M. Valin, *Commentaire sur l'Ordonnance de 1681*, t. ii. p. 147-198, ed. 1760; to Emerigon, *Traité des Assurances*, t. i. pp. 598-674; Arnould on *Marine Insurance*; and the treatises on *Average* of Stevens, Benecke, Baily, Hopkins, and Lowndes. (J. W. A.)

AVERNUS, a lake of Campania in Italy, near Baie, occupying the crater of an extinct volcano, and about a mile and a half in circumference. From the gloomy horror of its surroundings, and the mephitic character of its exhalations, it was regarded by ancient superstition as an entrance to the infernal regions. It was especially dedicated to Proserpine, and an oracle was maintained on the spot. In 214 B.C., Hannibal with his army visited the shrine, but not so much, according to Pliny, for purposes of piety, as in hope of surprising the garrison of Puteoli. By some critics the Cimmerians of Homer were supposed to have been the inhabitants of this locality, and Virgil in his *Æneid* adopted the popular opinions in regard to it. Originally there seems to have been no outlet to the lake, but Agrippa opened a passage to the Lucrine, and turned this "mouth of hell" into a harbour for ships. The channel, however, appears to have become obstructed at a later period. In the reign of Nero it was proposed to construct a ship-canal from the Tiber through Avernus to the Gulf of Baie, but the works were hardly commenced. The plan of connecting the lake with the Gulf of Baie was brought forward as late as 1858, but only to be abandoned. The *Lago d'Averno* is now greatly frequented by foreign tourists, who are shown what pass for the Sibyl's Grotto, the Sibyl's Bath, and the entrance to the infernal regions, as well as the tunnel from Cumæ, and ruins variously identified as belonging to a temple or a bathing-place.

AVERROES, known among his own people as Abû-Walid Mohammed Ibn-Ahmed Ibn-Mohammed IBN-ROSHD, the kâdi, was born at Cordova in 1126, and died at Marocco in 1198. His early life was occupied in mastering the curriculum of theology, jurisprudence, mathematics, medicine, and philosophy, under the approved teachers of the time. The years of his prime were a disastrous era for Mahometan Spain, where almost every city had its own petty king, whilst the Christian princes swept the land in constant inroads. But with the advent of the Almohades, the enthusiasm which the desert tribes had awakened, whilst it revived religious life and intensified the observance of the holy law within the realm, served at the same time to reunite the forces of Andalusia, and inflicted decisive defeats on the chiefs of the Christian North. For the last time before its final extinction the Moslem caliphate in Spain displayed a splendour which seemed to rival the ancient glories of the Omniade court. Great mosques arose; schools and colleges were founded; hospitals, and other useful and beneficent constructions, proceeded from the public zeal of the sovereign; and under the patronage of two liberal rulers, Jusuf and Jakûb, science and philosophy flourished apace. It was Ibn-Tofail (Abubacer), the philosophic vizier of Jusuf, who introduced Averroes to that prince, and Avenzoar (Ibn-Zohr), the greatest of Moslem physicians, was his friend. Averroes, who was versed in the Malekite system of law, was made kâdi of Seville (1169), and in similar appointments the next twenty-five years of his life were passed. We find him at different periods in Seville, Cordova, and Marocco, probably follow-

ing the court of Jusuf Almansur, who took pleasure in engaging him in discussions on the theories of philosophy and their bearings on the faith of Islam. But science and free thought then, as now, in Islam, depended almost solely on the tastes of the wealthy and the favour of the monarch. The ignorant fanaticism of the multitude viewed speculative studies with deep dislike and distrust, and deemed any one a Zendik (infidel) who did not rest content with the natural science of the Koran. These smouldering hatreds burst into open flame about the year 1196. Whether, as one story ran, he had failed in conversation and in his writings to pay the customary deference to the emir, or a court intrigue had changed the policy of the moment, at any rate Averroes was accused of heretical opinions and pursuits, stripped of his honours, and banished to a place near Cordova, where his actions were closely watched. Tales have been told of the insults he had to suffer from a bigoted populace. At the same time efforts were made to stamp out all liberal culture in Andalusia, so far as it went beyond the little medicine, arithmetic, and astronomy required for practical life. But the storm soon passed, when the transient passion of the people had been satisfied, and Averroes for a brief period survived his restoration to honour. He died in the year before his patron Almansur, with whom (in 1199) the political power of the Moslems came to an end, as did the culture of liberal science with Averroes. The philosopher left several sons, some of whom became jurists like Averroes's grandfather. One of them has left an essay, expounding his father's theory of the intellect. The personal character of Averroes is known to us only in a general way, and as we can gather it from his writings. His clear, exhaustive, and dignified style of treatment evidences the rectitude and nobility of the man. In the histories of his own nation he has little place; the renown which spread in his lifetime to the East ceased with his death, and he left no school. Yet, from a note in a manuscript, we know that he had intelligent readers in Spain more than a century afterwards. His historic fame came from the Christian Schoolmen, whom he almost initiated into the system of Aristotle, and who, but vaguely discerning the expositors who preceded, admired in his commentaries the accumulated results of two centuries of labour.

For Aristotle the reverence of Averroes was unbounded, and to expound him was his chosen task. The uncritical receptivity of his age, the defects of the Arabic versions, the emphatic theism of his creed, and the rationalising mysticism of some Oriental thought, may have sometimes led him astray, and given prominence to the less obvious features of Aristotelianism. But in his conception of the relation between philosophy and religion, Averroes had a light which the Latins were without. The science, falsely so called, of the several theological schools, their groundless distinctions and sophistical demonstrations, he regarded as the great source of heresy and scepticism. The allegorical interpretations and metaphysics which had been imported into religion had taken men's minds away from the plain sense of the Koran, and destroyed the force of those appeals which had been spoken to the hearts and understandings of our common humanity, not to the wisdom of the "people of demonstration." God had declared a truth meet for all men, which needed no intellectual superiority to understand, in a tongue which each human soul could apprehend according to its powers and feelings. Accordingly, the expositors of religious metaphysics, Algazali included, are the enemies of true religion, because they make it a mere matter of syllogism. Averroes maintains that a return must be made to the words and teaching of the prophet; that science must not expend itself in dogmatizing on the metaphysical consequences of fragments of doctrine. For

popular acceptance, but must proceed to reflect upon and examine the existing things of the world. Averroes, at the same time, condemns the attempts of those who tried to give demonstrative science where the mind was not capable of more than rhetoric: they harm religion by their mere negations, destroying an old sensuous creed, but cannot build up a higher and intellectual faith.

In this spirit Averroes does not allow the fancied needs of theological reasoning to interfere with his study of Aristotle, whom he simply interprets as a truth-seeker. The points by which he told on Europe were all implicit in Aristotle, but Averroes set in relief what the original had left obscure, and emphasised things which the Christian theologian passed by or misconceived. Thus Averroes had a double effect. He was the great interpreter of Aristotle to the later Schoolmen, worthy of a place, according to Dante, beside the glorious sages of the heathen world. On the other hand, he came to represent those aspects of Peripateticism most alien to the spirit of Christendom; and the deeply-religious Moslem gave his name to the anti-sacerdotal party, to the materialists, sceptics, and atheists, who defied or undermined the dominant beliefs of the church.

On three points Averroes, like other Moslem thinkers, came specially into relation, real or supposed, with the religious creed, viz., the creation of the world, the divine knowledge of particular things, and the future of the human soul. But the collision was rather with the laboured ratiocinations by which the Asharite and Motazelite theologians aimed at rationalising dogma than with the doctrine of religion in its simplicity. True philosophy is the foster sister of religion, but is the critic of scholastic subtleties. In regard to the second charge, Averroes himself remarks that philosophy only protests against reducing the divine to the level of the created mind. But the real grandeur of Averroes is seen in his resolute prosecution of the stand-point of science in matters of this world, and in his recognition that religion is not a branch of knowledge to be reduced to propositions and systems of dogma, but a personal and inward power, an individual truth which stands distinct from, but not contradictory to, the universalities of scientific law. In his science he followed the Greeks, and to the Schoolmen he and his compatriots rightly seemed philosophers of the ancient world. He maintained alike the claim of demonstrative science with its generalities for the few who could live in that ethereal world, and the claim of religion for all,—the common life of each soul as an individual and personal consciousness. But theology, or the mixture of the two, he regarded as a source of evil to both—fostering the vain belief in a hostility of philosophers to religion, and meanwhile corrupting religion by a pseudo-science. A stand-point like this was the very antithesis of scholasticism; it was the anticipation of an adequate view which modern speculation has seldom exhibited.

The latent nominalism of Aristotle only came gradually to be emphasised through the prominence which Christianity gave to the individual life, and, apart from passing notices as in Abelard, first found clear enunciation in the school of Duns Scotus. The Arabians, on the contrary, emphasised the idealist aspect which had been adopted and promoted by the Neo-Platonist commentators. Hence, to Averroes the eternity of the world finds its true expression in the eternity of God. The ceaseless movement of growth and change, which presents matter in form after form as a continual search after a finality which in time and movement is not, and cannot be reached, represents only the aspect the world shows to the physicist and to the senses. In the eye of reason the full fruition of this desired finality is already and always attained; the

actualisation, invisible to the senses, is achieved now and ever, and is thus beyond the element of time. This transcendent or abstract being is that which the world of nature is always seeking. He is thought or intellect, the actuality, of which movement is but the fragmentary attainment in successive instants of time. Such a mind is not in the theological sense a creator, yet the onward movement is not the same as what some modern thinkers seem to mean by development. For the perfect and absolute, the consummation of movement is not generated at any point in the process; it is an ideal end, which guides the operations of nature, and does not wait upon them for its achievement. God is the unchanging essence of the movement, and therefore its eternal cause.

A special application of this relation between the prior perfect, and the imperfect, which it influences, is found in the doctrine of the connection of the abstract (transcendent) intellect with man. This transcendent mind is sometimes connected with the moon, according to the theory of Aristotle, who assigned an imperishable matter to the sphere beyond the sublunary, and in general looked upon the celestial orbs as living and intelligent. Such an intellect, named active or productive, as being the author of the development of reason in man, is the permanent, eternal thought, which is the truth of the cosmic and physical movement. It is in man that the physical or sensible passes most evidently into the metaphysical and rational. Humanity is the chosen vessel in which the light of the intellect is revealed; and so long as mankind lasts there must always be some individuals destined to receive this light. "There must of necessity always be some philosopher in the race of man." What seems from the material point of view to be the acquisition of learning, study, and a moral life, is from the higher point of view the manifestation of the transcendent intellect in the individual. The preparation of the heart and faculties gives rise to a series of grades between the original predisposition and the full acquisition of actual intellect. These grades in the main resemble those given by Avicenna. But beyond these, Averroes claims as the highest bliss of the soul a union in this life with the actual intellect. The intellect, therefore, is one and continuous in all individuals, who differ only in the degree which their illumination has attained. Such was the Averroist doctrine of the unity of intellect—the eternal and universal nature of true intellectual life. By his interpreters it was transformed into a theory of one soul common to all mankind, and when thus corrupted conflicted not unreasonably with the doctrines of a future life, common to Islam and Christendom.

Averroes, rejected by his Moslem countrymen, found a hearing among the Jews, to whom Maimonides had shown the free paths of Greek speculation. In the cities of Languedoc and Provence, to which they had been driven by Spanish fanaticism, the Jews no longer used the learned Arabic, and translations of the works of Averroes became necessary. His writings became the text-book of Levi ben Gerson at Perpignan, and of Moses of Narbonne. Meanwhile, before 1250, Averroes became accessible to the Latin Schoolmen by means of versions, accredited by the names of Michael Scot and others. William of Auvergne is the first Schoolman who criticises the doctrines of Averroes, not, however, by name. Albertus Magnus and St Thomas devote special treatises to an examination of the Averroist theory of the unity of intellect, which they labour to confute in order to establish the orthodoxy of Aristotle. But as early as Egidius Romanus (1247-1316), Averroes had been stamped as the patron of indifference to theological dogmas, and credited with the emancipation which was equally due to wider experience and the lessons of the Crusades. There had never been an absence of protest

against the hierarchical doctrine. Berengar had struggled in that interest, and with Abelard, in the 12th century, the revolt against authority in belief grew loud. The dialogue between a Christian, a Jew, and a philosopher suggested a comparative estimate of religions, and placed the natural religion of the moral law above all positive revelations. Nihilists and naturalists, who deified logic and science at the expense of faith, were not unknown at Paris in the days of John of Salisbury. In such a critical generation the words of Averroism found willing ears, and pupils who outran their teacher. Paris became the centre of a sceptical society, which the decrees of bishops and councils, and the enthusiasm of the orthodox doctors and knight-errants of Catholicism, were powerless to extinguish. At Oxford Averroes told more as the great commentator. In the days of Roger Bacon he had become an authority. Bacon, placing him beside Aristotle and Avicenna, recommends the study of Arabic as the only way of getting the knowledge which had versions made almost hopeless; and the student of the present day might echo his remark. In Duns Scotus, Averroes and Aristotle are the unequalled masters of the science of proof; and he pronounces distinctly the separation between Catholic and philosophical truth, which became the watchword of Averroism. By the 14th century Averroism was the common heaven of philosophy; John Baconthorpe is the chief of Averroists, and Walter Burley has similar tendencies.

Meanwhile Averroism had, in the eye of the great Dominican school, come to be regarded as the arch-enemy of the truth. When Frederick II. consulted a Moslem free-thinker on the mysteries of the faith, when the phrase or legend of the "Three Impostors" presented in its most offensive form the scientific survey of the three laws of Moses, Christ, and Mahomet, and when the characteristic doctrines of Averroes were misunderstood, it soon followed that his name became the badge of the scoffer and the sceptic. What had begun with the subtle disputes of the universities of Paris, went on to the materialist teachers in the medical schools and the sceptical men of the world in the cities of Northern Italy. The patricians of Venice and the lecturers of Padua made Averroism synonymous with doubt and criticism in theology, and with sarcasm against the hierarchy. Petrarch, vexed by the arrogance and over-refinements of their argumentation, and by the barbarism of their words, refuses to believe that any good thing can come out of Arabia, and speaks of Averroes as a mad dog barking against the church. In works of contemporary art Averroes is at one time the comrade of Mahomet and Antichrist; at another he lies with Arius and Sabellius, vanquished by the lance of St. Thomas.

It was in the universities of North Italy that Averroism finally settled, and there for three centuries it continued as a stronghold of Scholasticism to resist the efforts of revived antiquity and of advancing science. Padua became the seat of Averroist Aristotelianism; and, when Padua was conquered by Venice in 1405, the printers of the republic spread abroad the teaching of the professors in the university. As early as 1300, at Padua, Petrus Aponensis, a notable expositor of medical theories, had betrayed a heterodoxy in faith; and John of Jandun, one of the pamphleteers on the side of Lewis of Bavaria, was a keen follower of Averroes, whom he styles a "perfect and most glorious physician." Urbanus of Bologna, Paul of Venice (d. 1428), and Cajetanus de Thienis (1387-1465), established by their lectures and their discussions the authority of Averroes; and a long list of manuscripts rests in the libraries of Lombardy to witness the diligence of these writers and their successors. Even a lady of Venice, Cassandra Fedele, in 1480, gained her laurels in defence of Averroist theses.

With Pomponatius, in 1495, a brilliant epoch began for the school of Padua. Questions of permanent and present interest took the place of outworn scholastic problems. The disputants ranged themselves under the rival commentators, Alexander and Averroes; and the immortality of the soul became the battle-ground of the two parties. Pomponatius defended the Alexandrist doctrine of the utter mortality of the soul, whilst Augustinus Niphus, the Averroist, was entrusted by Leo X. with the task of defending the Catholic doctrine. The parties seemed to have changed when Averroism thus took the side of the church; but the change was probably due to compulsion. Niphus had edited the works of Averroes (1495-7); but his expressions gave offence to the dominant theologians, and he had to save himself by distinguishing his personal faith from his editorial capacity. Achillini, the persistent philosophical adversary of Pomponatius both at Padua and subsequently at Bologna, attempted, along with other moderate but not brilliant Averroists, to accommodate their philosophical theory with the requirements of Catholicism. It was this comparatively mild Averroism, reduced to the merely explanatory activity of a commentator, which continued to be the official dogma at Padua during the 16th century. Its typical representative is Marc-Antonio Zimara (d. 1552), the author of a reconciliation between the tenets of Averroes and those of Aristotle.

Meanwhile, in 1497, Aristotle was for the first time expounded in Greek at Padua. Plato had long been the favourite study at Florence; and Humanists, like Erasmus, Ludovicus Vives, and Nizolius, enamoured of the popular philosophy of Cicero and Quintilian, poured out the vials of their contempt on scholastic barbarism with its "impious and thrice-accursed Averroes." The editors of Averroes complain that the popular taste had forsaken them for the Greek. Nevertheless, while Fallopius, Vesalius, and Galileo were claiming attention to their discoveries, the Professors Zabarella, Piccolomini, Pendasio, and Cremonini continued the traditions of Averroism, not without changes and additions. Cremonini, the last of them, died in 1631, after lecturing twelve years at Ferrara, and forty at Padua. The legend which tells that he laid aside his telescope rather than see Jupiter's moons, which Galileo had discovered, is a parable of the fall of scholastic Averroism. Medievalism, with its misconstruction of Averroes, perished because it would not see that the interpretation of the past calls for the ripest knowledge of all discoveries in the present.

The literary works of Averroes include treatises on jurisprudence, grammar, astronomy, medicine, and philosophy. In 1859, a work of Averroes was for the first time published in Arabic by the Bavarian Academy, and a German translation appeared in 1875 by the editor, J. Müller. It is a treatise entitled *Philosophy and Theology*, and, with the exception of a German version of the essay on the conjunction of the intellect with man, is the first translation which enables the non-Semitic scholar to form any adequate idea of Averroes. The Latin translations of most of his works are barbarous and obscure. A great part of his writings, particularly on jurisprudence and astronomy, as well as essays on special logical subjects, prologomena to philosophy, criticisms on Avicenna and Alfarabius, remain in manuscript in the Escorial and other libraries. The Latin editions of his medical works include the *Colliget* (i.e., Kulliyat, or summary), a *resumé* of medical science, and a commentary on Avicenna's poem on medicine; but Averroes, in medical renown, always stood far inferior to Avicenna. The Latin editions of his philosophical works comprise the *Commentaries on Aristotle*, the *Destructio Destructionis* (against Algazali), the *De Substantia Orbis*, and a double treatise *De Anima Beatiitudinis*. The Commentaries of Averroes fall under three heads:—the larger commentaries, in which a paragraph is quoted at large, and its clauses expounded one by one; the medium commentaries, which cite only the first words of a section; and the paraphrases or analyses, treatises on the subjects of the Aristotelian books. The larger commentary was an innovation of Averroes; for Avicenna, copied by Albertus Magnus, gave under the rubrics furnished by Aristotle works in which, though the materials were borrowed, the grouping was his own. The great

commentaries exist only for the *Posterior Analytica*, *Physics*, *De Caelo*, *De Anima*, and *Metaphysics*. On the *History of Animals* no commentary at all exists, and Plato's *Republic* is substituted for the then inaccessible *Politics*. The Latin editions of these works between 1480 and 1880 number about 100. The first appeared at Padua, 1473; about fifty were published at Venice, the best known being that by the Juntas (1552-3), in ten volumes folio.

See Beman, *Averroes et Averroïsmes*; Munk, *Mélanges*, 418-458; Müller's German translation, *Philosophie und Theologie*, München, 1875; Stöckl, *Phil. d. Mittelalters*, ii. 67-124; Averroes (Vatar und Sohn), *Drei Abhandl. über d. Conjunction d. separaten Intellekts mit d. Menschen*, translated into German from the Arabic version of Sem. Ibn-Tibbon, by Dr J. Herz, Berlin, 1869. (W. W.)

**AVERSA**, a town of Italy, province of Terra di Lavoro, situated in a beautiful plain covered with orange-groves and vineyards, about midway between Naples and Capua. It is the seat of a wealthy bishopric, and its founding hospital and lunatic asylum, the latter founded by Murat, are very celebrated. Aversa owed its origin to the Normans, and dates from 1030, the people of the ancient city of Atella being transported thither. Population, 21,176.

**AVESNES**, a town of France, in the department of Nord; situated in a fertile district on the Greater Helpe. It is generally well built, and is fortified on Vauban's system. Its principal building is the cathedral, surmounted by a tower 350 feet high, which is raised on four columns, and has a fine chime. It is the seat of a sub-prefect, and has a tribunal of primary jurisdiction, an agricultural society, and a communal college. The principal manufactures are hosiery, coarse serge, and soap; there are also breweries, tanneries, salt-refineries, and brick and marble works. A great part of the town was destroyed by the explosion of a powder-magazine during the siege by the Prussians in July 1815, but was soon afterwards rebuilt. Population, 3737.

**AVEYRON**, a department in the S. of France, bounded on the N. by Cantal, E. by Lozère, S. by Hérault and Tarn, and W. by Tarn-et-Garonne and Lot, containing an area of 3429 square miles. It corresponds to a large portion of the ancient district of Rouergue in Guienne, which formerly gave its name to a family of counts. Its earliest inhabitants known to us were the Rutheni, whose capital was Segodunum, identified with the modern Rodez. The department is rich in prehistoric antiquities, such as the dolmens at Taurines, Laumières, Grailhe, &c. (see paper by M. E. Cartailhac in Norwich vol. of *Internat. Cong. of Prehist. Arch.*, 1868). A large portion of Aveyron is occupied by offshoots of the Cevennes, the highest summit being Cham-de-la-Roche, 4350 feet above the level of the sea. About half the area is under cultivation, nearly one-fourth is heath, one-tenth woods and forests, and rather more than an eighth part meadow land. Vineyards occupy about one-twelfth part of the cultivated land. The department has mines of copper, lead, silver, iron, zinc, alum, and antimony, and extensive coal-fields of great value. Rather more than three-fourths of the inhabitants are engaged in agricultural pursuits of one kind or another, —mainly in the rearing of cattle, sheep, and swine; and there are manufactures of paper, woollen and cotton goods, silk, and leather, to which water-power is skilfully applied. Aveyron exports chestnuts, almonds, hemp, wool, wax, the famous Roquefort cheese, timber, and cattle. Among the numerous men of mark belonging to the department may be mentioned Jean de la Valette, the defender of Malta, Raynal, Bonald, and Louis Blanc. The capital is Rodez, and the arrondissements are Rodez, Espalion, Milhan, Saint-Affrique, and Villefranche. Population in 1872, 402,474. For investigations into the races represented in the department see *Bulletins de la Soc. d'Anthrop.* vol. iv.

**AVEZZANO**, a town of Italy, in Abruzzo Ulteriore II., containing a castle, which was built in 1499 by Virgilio

Orsini, afterwards belonged to the family of the Colonnas, and is now in the possession of the Barberinis. Population about 5900. Long. 13° 32' E., lat. 41° 58' N.

**AVICEBRON**. The writer referred to by the Scholastics of the 13th century under this name was supposed by them to be an Arabian philosopher, and was accordingly classed along with Avempace, Abubacer, and others. Recent researches have shown that this is an error, and that this author, about whom so little was known, is identical with Salomon ben Gebirol, a Jewish writer, several of whose religious poems are still celebrated among the Jews. Few details are known regarding the life of Gebirol. He was born at Malaga, and received his education at Saragossa, where, in 1045, he wrote a small treatise on morals, which has been several times reprinted. His death is said to have taken place in 1070 at Valencia. Among the Jews he is known only through his poems, and, with a few unimportant exceptions, no Jewish writer refers to his philosophical speculations. The Christian Schoolmen, about the middle of the 12th century, became acquainted with Gundisalvi's Latin translation of a work called *Fons Vitæ* or *Sapientia*, which exercised a powerful influence on their metaphysical discussions. The author was called by them Avicebron, or Avicembron, or Avencebrol, and nothing was known regarding him till M. Munk discovered a Hebrew abridgment, by Ibn Falaguera, of Rabbi S. ben Gebirol's treatise on the source of life. He readily identified this with the work of the unknown Avicebron, and the discovery of two Latin MSS. of the *Fons* has placed the identification beyond doubt. The extracts of Falaguera give a fair idea of the work, and enable us to understand the peculiar influence it exercised. The objects of metaphysics according to it are three in number, the knowledge of matter and form, of the divine will or creative word, and of the supreme unity of God. God, as infinite, cannot be known by intelligence which is finite, for all knowledge involves comprehension, or requires that the known be contained in the knowing. God works through the divine will, which is intermediate between the supreme unity and the world. All things in the world possess both matter and form; all the various species of matter are but variations of one universal matter; and similarly all forms are contained in one universal form. This unity of matter applies to the soul and mind as well as to material things, and it is against this proposition that the orthodox Schoolmen, as Albertus and Thomas, principally argue. The matter and form in the universe is disposed in successive stages, and rising above the lowest grade or corporal matter there are certain intermediate substances uniting it with the divine will, without which there is no motion. These intermediate substances, taken in order, are —the universal intellect, the rational soul, the vital soul, the vegetative soul, and nature, or the principle of motion in material things. Activity is transmitted from the divine will through these stages, each of which causes the one next below itself to pass from potentiality into actuality. The materials of Avicembron's philosophy are due mainly to the Alexandrian speculations concealed in the pseudo-Aristotelian *Theology*. The position of the divine will, somewhat enigmatical in a philosophical point of view, is probably a concession to Jewish orthodoxy. For a full account of all that is known regarding Avicembron's life and philosophy, with translation of Falaguera's extracts, see Munk's *Mélanges de Phil. Juive et Arabe*, pp. 1-306; for his poems see Sachs's *Die Religiöse Poesie der Juden in Spanien*, and Geiger's *S. ben Gebirol und seine Dichtungen*. **AVICENNA** (in Arabic, Abū Ali el-Hosain Ibn-Abdallah IAN-SINA) was born about the year 980 A.D. at Afshena, one of the many hamlets in the district of Bokhara. His mother was a native of the place; his father, a Persian

from Balkh, filled the post of tax-collector in the neighbouring town of Harmaitin, under Nûh ibn Mansûr, the Samanide emir of Bokhara. On the birth of Avicenna's younger brother the family migrated to the capital, then one of the chief cities of the Moslem world, and famous for a culture which was older than its conquest by the Saracens. Avicenna was put in charge of a tutor, and his precocity soon made him the marvel of his neighbours,—as a boy of ten who knew by rote the Koran and much Arabic poetry besides. From a greengrocer he learnt arithmetic; and higher branches were begun under one of those wandering scholars, who gained a livelihood by cures for the sick and lessons for the young. Under him Avicenna read the *Isagoge* of Porphyry, and the first propositions of Euclid. But the pupil soon found his teacher to be but a charlatan, and betook himself, aided by commentaries, to master logic, geometry, and the *Almagest*. Before he was sixteen he not merely knew medical theory, but by gratuitous attendance on the sick had, according to his own account, discovered new methods of treatment. For the next year and a half he worked at the higher philosophy, in which he encountered greater obstacles. In such moments of baffled inquiry he would leave his books, perform the requisite ablutions, then hie to the mosque, and continue in prayer till light broke on his difficulties. Deep into the night he would continue his studies, stimulating his senses by occasional cups of wine, and even in his dreams problems would pursue him and work out their solution. Forty times, it is said, he read through the metaphysics of Aristotle, till the words were imprinted on his memory; but their meaning was hopelessly obscure, until one day they found illumination from the little commentary by Alfarabius, which he bought at a bookstall for the small sum of three drachmæ. So great was his joy at the discovery, thus made by help of a work from which he had expected only mystery, that he hastened to return thanks to God, and bestowed an alms upon the poor. Thus, by the end of his seventeenth year, he had gone the round of the learning of his time; his apprenticeship of study was concluded, and he went forth a master to find a market for his accomplishments.

His first appointment was that of physician to the emir, whom the fame of the youthful prodigy had reached, and who owed him his recovery from a dangerous illness. Avicenna's chief reward for this service was access to the royal library, contained in several rooms, each with its chests of manuscripts in some branch of learning. The Samanides were well-known patrons of scholarship and scholars, and stood conspicuous amid the fashion of the period, which made a library and a learned retinue an indispensable accompaniment of an emir, even in the days of campaign. In such a library Avicenna could inspect works of great rarity, and study the progress of science. When the library was destroyed by fire not long thereafter, the enemies of Avicenna accused him of burning it, in order for ever to conceal the sources of his knowledge. Meanwhile, he assisted his father in his financial labours, but still found time to write some of his earliest works for two wealthy patrons, whose absolute property they became. Among them was the *Collectio*, one of those short synopses of knowledge which an author threw off for different patrons.

At the age of twenty-two Avicenna lost his father. The Samanide dynasty, which for ten years had been hard pressed between the Turkish Khan of Kashgar on the north and the rulers of Ghazni on the south, came to its end in December 1004. Avicenna seems to have declined the offers of Mahmud the Ghaznevide (who, like his compeers, was rapidly gathering a brilliant cortege of savants, including the astronomer Albiruni), and proceeded westwards to

the city of Urdjansh in the modern district of Khiva, where the vizier, regarded as a friend of scholars, gave him a small monthly stipend. But the pay was small, and Avicenna wandered from place to place through the districts of Nishapur and Merv to the borders of Khorasan, seeking an opening for his talents. In the restless change which threw the several cities of Iran from hand to hand among those feudal emirs of the Buide family, who disputed the fragments of the caliphate, the interests of letters and science were not likely to be regarded. Shams al-Ma'ali Kabûs, the generous ruler of Deilem, himself a poet and a scholar, with whom he had expected to find an asylum, was about that date (1013) starved to death by his own revolted soldiery. Avicenna himself was at this season stricken down by a severe illness. Finally, at Jorjân, near the Caspian, he met with a friend, who bought near his own house a dwelling in which Avicenna lectured on logic and astronomy. For this patron several of his treatises were written; and the commencement of his *Canon of Medicines* also dates from his stay in Hyrcania.

He subsequently settled at Rai, in the vicinity of the modern Teheran, where a son of the last emir, Me'ij Addaula, was nominal ruler, under the regency of his mother. At Rai about thirty of his shorter works are said to have been composed. But the constant feuds which raged between the regent and her second son, Shams Addaula, compelled the scholar to quit the place, and after a brief sojourn at Kaswin, he passed southwards to Hamadân, where that prince had established himself. At first he entered into the service of a high-born lady; but ere long the emir, hearing of his arrival, called him in as medical attendant, and sent him back with presents to his dwelling. Avicenna was even raised to the office of vizier; but the turbulent soldiery, composed of Koords and Turks, mutinied against their nominal sovereign, and demanded that the new vizier should be put to death. Shams Addaula consented that he should be banished from the country. Avicenna, however, remained hidden for forty days in a sheikh's house, till a fresh attack of illness induced the emir to restore him to his post. Even during this perturbed time he prosecuted his studies and teaching. Every evening extracts from his great works, the *Canon* and the *Sanatio*, were dictated and explained to his pupils; among whom, when the leech was over, he spent the rest of the night in festive enjoyment with a band of singers and players. On the death of the emir Avicenna ceased to be vizier, and hid himself in the house of an apothecary, where, with intense assiduity, he continued the composition of his works. Meanwhile, he had written to Abu Jaafar, the prefect of Ispahan, offering his services; but the new emir of Hamadân getting to hear of this correspondence, and discovering the place of Avicenna's concealment, incarcerated him in a fortress. War meanwhile continued between the rulers of Ispahan and Hamadân; in 1024 the former captured Hamadân and its towns, and expelled the Turkish mercenaries. When the storm had passed Avicenna returned with the emir to Hamadân, and carried on his literary labours; but at length, accompanied by his brother, a favourite pupil, and two slaves, made his escape out of the city in the dress of a Sufite ascetic. After a perilous journey they reached Ispahan, and received an honourable welcome from the prince. The remaining ten or twelve years of Avicenna's life were spent in the service of Abu Jaafar Ala Addaula, whom he accompanied as physician and general literary and scientific adviser, even in his numerous campaigns. During these years he began to study literary matters and philology, instigated, it is asserted, by criticisms on his style. But amid his restless study Avicenna never forgot his love of enjoyment. Unusual bodily vigour enabled him to combine severe

devotion to work with facile indulgence in sensual pleasures. His passion for wine and women was almost as well known as his learning. With much gaiety of heart, and great powers of understanding, he showed at the same time the spirit of an Aristippus more than that of an Aristotle at the courts of the wealthy. Versatile, light-hearted, boastful, and pleasure-loving, he contrasts with the nobler and more intellectual character of Averroes. His bouts of pleasure gradually weakened his constitution; a severe colic, which seized him on the march of the army against Hamadán, was checked by remedies so violent that Avicenna could scarcely stand. On a similar occasion the disease returned; with difficulty he reached Hamadán, where, finding the disease gaining ground, he refused to keep up the regimen imposed, and resigned himself to his fate. On his deathbed remorse seized him; he bestowed his goods on the poor, restored unjust gains, freed his slaves, and every third day till his death listened to the reading of the Koran. He died in June 1037, in his 58th year, and was buried among the palm-trees by the Kiblah of Hamadán.

It was mainly accident which determined that from the 12th to the 17th century Avicenna should be the guide of medical study in European universities, and eclipse the names of Rhazes, Ali, and Avenzoar. His work is not essentially different from that of his predecessors Rhazes and Ali; all present the doctrine of Galen, and through Galen the doctrine of Hippocrates, modified by the system of Aristotle. The *Canon* of Avicenna is distinguished from the *El-Hawi* (*Continens*) or *Summary* of Rhazes by its greater method, due perhaps to the logical studies of the former, and entitling him to his surname of Prince of the Physicians. The work has been variously appreciated in subsequent ages, some regarding it as a treasury of wisdom, and others, like Avenzoar, holding it useful only as waste paper. In modern times it has been more criticised than read. The vice of the book is excessive classification of bodily faculties, and over-subtlety in the discrimination of diseases. It includes five books; of which the first and second treat of physiology, pathology, and hygiene, the third and fourth deal with the methods of treating disease, and the fifth describes the composition and preparation of remedies. This last part contains some contingent of personal observation. He is, like all his countrymen, ample in the enumeration of symptoms, and is said to be inferior to Ali in practical medicine and surgery. He introduced into medical theory the four causes of the Peripatetic system. Of natural history and botany he pretends to no special knowledge. Up to the year 1650, or thereabouts, the *Canon* was still used as a text-book in the universities of Louvain and Montpellier.

The rank of Avicenna in the mediæval world as a philosopher was far beneath his fame as a physician. Still, the logic of Albertus Magnus and succeeding doctors was largely indebted to him for its formulae. In logic Avicenna starts from distinguishing between the isolated concept and the judgment or assertion; from which two primitive elements of knowledge there is artificially generated a complete and scientific knowledge by the two processes of definition and syllogism. But the chief interest for the history of logic belongs to his doctrine in so far as it bears upon the nature and function of abstract ideas. The question had been suggested alike to East and West by Porphyry, and the Arabians were the first to approach the full statement of the problem. Alfarrabi pointed out that the universal and individual are not distinguished from each other as understanding from the senses, but that both universal and individual are in one respect intellectual, just as in another connection they play a part in perception. He had distinguished the universal essence in its abstract nature, from the universal considered in

relation to a number of singulars. These suggestions formed the basis of Avicenna's doctrine. The essences or forms—the *intelligibilia* which constitute the world of real knowledge—may be looked at in themselves (metaphysically), or as embodied in the things of sense (physically), or as expressing the processes of thought (logically). The first of these three points of view deals with the form or idea as self-contained in the principles of its own being, apart from those connections and distinctions which it receives in real (sensuous) science, and through the act of intellect. Secondly, the form may be looked at as the similarity evolved by a process of comparison, as the work of mental reflection, and in that way as essentially expressing a relation. When thus considered as the common features derived by examination from singular instances, it becomes a universal or common term strictly so called. It is intellect which first makes the abstract idea a true universal. (*Intellectus in formis agit universalitatem.*) In the third place, the form or essence may be looked upon as embodied in outward things (*in singularibus propriis*), and thus it is the type more or less represented by the members of a natural kind. It is the designation of these outward things which forms the "first intention" of names; and it is only at a later stage, when thought comes to observe its own modes, that names, looked upon as predicables and universals, are taken in their "second intention." Logic deals with such second intentions. It does not consider the forms *ante multiplicatam*, i.e., as eternal ideas—nor *in multiplicatam*, i.e., as immersed in the matter of the phenomenal world—but *post multiplicatam*, i.e., as they exist in and for the intellect which has examined and compared. Logic does not come in contact with things, except as they are subject to modification by intellectual forms. In other words, universality, individuality, and speciality are all equally modes of our comprehension or notion; their meaning consists in their setting forth the relations attaching to any object of our conception. In the mind, e.g., one form may be placed in reference to a multitude of things, and as thus related will be universal. The form animal, e.g., is an abstract intelligible, or metaphysical idea. When an act of thought employs it as a schema to unify several species, it acquires its logical aspect (*respectus*) of generality; and the various living beings qualified to have the name animal applied to them constitute the natural class or kind. Avicenna's view of the universal may be compared with that of Abelard, which calls it "that whose nature it is to be predicated of several," as if the generality became explicit only in the act of predication, in the *sermo* or proposition, and not in the abstract, unrelated form or essence. The three modes of the universal before things, in things, and after things, spring from Arabian influence, but depart somewhat from his stand-point.

The place of Avicenna amongst Moslem philosophers is seen in the fact that Shahrastani takes him as the type of all, and that Algazali's attack against philosophy is in reality almost entirely directed against Avicenna. His system is in the main a codification of Aristotle modified by fundamental views of Neo-Platonist origin, and it tends to be a compromise with theology. In order, for example, to maintain the necessity of creation, he taught that all things except God were admissible or possible in their own nature, but that certain of them were rendered necessary by the act of the creative first agent,—in other words, that the possible could be transformed into the necessary. Avicenna's theory of the process of knowledge is an interesting part of his doctrine. Man has a rational soul, one face of which is turned towards the body, and, by the help of the higher aspect, acts as practical understanding; the other face lies open to the reception and acquisition of the intelligible forms, and its aim is to become a reason-

able world, reproducing the forms of the universe and their intelligible order. In man there is only the susceptibility to reason, which is sustained and helped by the light of the active intellect. Man may prepare himself for this influx by removing the obstacles which prevent the union of the intellect with the human vessel destined for its reception. The stages of this process to the acquisition of mind are generally enumerated by Avicenna as four; in this part he follows not Aristotle, but the Greek commentator. The first stage is that of the hylic or material intellect, a state of mere potentiality, like that of a child for writing, before he has ever put pen to paper. The second stage is called in *habitu*; it is compared to the case of a child that has learned the elements of writing, when the bare possibility is on the way to be developed, and is seen to be real. In this period of half-trained reason, it appears as happy conjecture, not yet transformed into art or science proper. When the power of writing has been actualised, we have a parallel to the *intellectus in actu*—the way of science and demonstration is entered. And when writing has been made a permanent accomplishment, or lasting property of the subject, to be taken up at will, it corresponds to the *intellectus adeptus*—the complete mastery of science. The whole process may be compared to the gradual illumination of a body naturally capable of receiving light. There are, however, grades of susceptibility to the active intellect, i.e., in theological language, to communication with God and his angels. Sometimes the receptivity is so vigorous in its affinity, that without teaching it rises at one step to the vision of truth, by a certain "holy force" above ordinary measure. (In this way philosophy tried to account for the phenomenon of prophecy, one of the ruling ideas of Islam.) But the active intellect is not merely influential on human souls. It is the universal giver of forms in the world.

In several points Avicenna endeavoured to give a rationale of theological dogmas, particularly of prophetic rule, of miracles, divine providence, and immortality. The permanence of individual souls he supports by arguments borrowed from those of Plato. The existence of a prophet is shown to be a corollary from a belief in God as a moral governor, and the phenomena of miracles are required to evidence the genuineness of the prophetic mission. For man, in order to his well-being and the permanence of his kind, requires in the first place a clear vision of right and truth, and must, secondly, depend upon some power capable of carrying out these discoveries of moral law. If providence has so arranged that the eyelids and the hair of the eyebrows shall grow to protect the eye, much more is it needful for a prophet to arise who shall preach the truth of God's unity, prescribe laws for men, and exhort them to well-doing by the promise of recompense to come. The weal of humanity demands the revelation from God, and, to certify his office, the prophet must work miracles. Just as in ordinary states the soul influences the bodily organs, so in exalted conditions it may attain the level of those high immaterial spirits, whose energy is strong enough to permeate the whole passive world. This mystical union with the hidden universe is a mystery which the ordinary mind cannot understand. Many things then become visible as by a lightning flash in the darkness, and are apprehended by the vigorous grasp of pure intuition. But more generally the imagination throws itself on these intuitions, and presents them to the lower soul under the semblance of forms and sounds—the angelic beauty which the seer beholds, and the harmonious speech which a heavenly voice seems to utter in his ear. Thus Avicenna, like his predecessors, tried to harmonise the abstract forms of philosophy with the religious faith of his nation. But his arguments are generally vitiated by the fallacy of

assuming what they profess to prove. His failure is made obvious by the attack of Algasali on the tendencies and results of speculation.

Upwards of 100 treatises are ascribed to Avicenna. Some of them are tracts of a few pages, others are works extending through several volumes. The best-known amongst them, and that to which Avicenna owed his European reputation, is the *Canon of Medicine*; an Arabic edition of it appeared at Rome 1598, and a Hebrew version at Naples in 1491. Of the Latin version there were about thirty editions, founded on the original translation by Gerard of Cremona. The 16th century has the honour of composing the great commentary on the text of the *Canon*, grouping around it all that theory had imagined, and all that practice had observed. Other medical works translated into Latin are the *Medicamenta Cordialis*, *Compendium de Medicina*, *Tractatus de Symplo Accato*. Scarcely any member of the Arabian circle of the sciences, including theology, philology, mathematics, astronomy, physics, and music, has been left untouched by the treatises of Avicenna, many of which probably varied little, except in being commissioned by a different patron and having a different form or extent. He wrote at least one treatise on alchemy, but several others have been falsely attributed to him. His book on animals was translated by Michael Scot. His *Logic*, *Metaphysics*, *Physics*, *De Caelo*, are treatises giving a synoptic view of Aristotelian doctrine. The *Logic* and *Metaphysics* have been printed more than once; the latter, e.g., at Venice in 1493, 1495, and 1546. Some of his shorter essays on medicine, logic, &c., take a poetical form (the poem on logic was published by Schmolders in 1836). Two encyclopaedic treatises, dealing with philosophy, are often mentioned. The larger, *Al-Shifa* (*Sanaio*), exists nearly complete in manuscript in the Bodleian Library and elsewhere; part of it on the *De Anima* appeared at Pavia (1490) as the *Liber Beatus Naturalium*, and the long account of Avicenna's philosophy given by Shahrastani seems to be mainly an analysis, and in many places a reproduction, of the *Al-Shifa*. A shorter form of the work is known as the *Al-Nafis* (*Liberatio*). The Latin editions of part of these works have been modified by the corrections which the monkish editors confess that they applied. There is also a *Philosophia Orientalis*, mentioned by Roger Bacon, and now lost, which according to Averroes was pantheistic in tone.

For Avicenna's life, see Ibn Khallikan's *Biographical Dictionary*, translated by Slane (1842); Wüstenfeld's *Geschichte der Arabischen Aerzte und Naturforscher*, Göttingen, 1840; Abul-Pharagius, *Historia Dynastiarum*. For his medicine, see Sprengel, *Histoire de la Médecine*; and for his philosophy, see Shahrastani, *Germ. transl.* vol. ii. 218-332; Prantl, *Geschichte der Logik*, ii. 818-361; Stöckl, *Phil. d. Mittelalters*, ii. 23-58; Munk, *Mélanges*, 352-366; and Haneberg in the *Abhandlungen der Philos.-Philolog. Class. der Bayerischen Academie*, 1867. (W. W.)

AVIENUS, BIVUS FESTUS, a Latin poet, who appears to have flourished in the latter half of the 4th century. Any knowledge we have of the facts of his life is derived from a Latin inscription, printed by Meyer (*Anthologia Latina*, 278), which has been supposed to refer to him. He is in all probability the Festus who was proconsul in Africa in 366 and following years, and in Achaia in 372. He is the author of the following works:—1. *Descriptio Orbis Terræ*, sometimes called *Metaphrasis Periagescos Dionysii*, being derived from the *περὶ γῆς* of that writer; 2. *Ora Maritima*, of which there is extant only a fragment describing the Atlantic coast, and the Mediterranean as far as Marseilles; 3. *Aratea Phenomena*, and *Aratea Prognostica*, which are paraphrases of two works of Aratus. These poems, with the exception of the *Aratea*, are contained in Wernsdorfer's *Poeta Latini Minores*, vol. v. pt. ii.

AVIGLIANO, a town of Italy, in the province of Basilicata, 11 miles N.N.W. of Potenza. It stands on the declivity of a hill, and contains a collegiate church, several convents, and a royal college. A peculiar kind of pottery produced here towards the end of the 18th century is still sought after by collectors. The surrounding country is said to produce the finest cattle in the kingdom. A part of the town was destroyed by a landslide in 1824. Population, 15,982.

AVIGNON, the chief town of the department of Vaucluse in France, situated in a beautiful plain, on the left bank of the Rhone, not far from the entrance of the Durance. It is surrounded by its ancient crenellated walls, which are in a state of remarkable preservation.

and, on the outside, by a line of pleasant boulevards planted with trees. A precipitous rock rises from the river's edge; and from its summit the cathedral of *Nôtre Dame des Doms*, a building of the 12th century, looks down on the city, but is almost thrown into insignificance by the Palace of the Popes, which rises by its side, and



Sketch Plan of Avignon.

1. Palace of the Popes. 2. Former Palace of the Archbishops. 3. Town-House & Calvet Museum. 4. Convent of the Visitation. 5. Theological Seminary (St Charles). 7. Hospital (St Louis). 8. Cavalry Barracks. 9. Barracks. 10. Penitentiary. 11. Infantry Barracks. 12. St Joseph's College. 13. Convent of the Holy Sacrament. 14. Hotel-Dieu and General Charity. 15. Church of St Symphorian. 16. Church of the Sacred Heart. 17. Prisons. 18. Savings Bank and Loan Office. 19. Court-House. 20. Lyceum. 21. Lyceum. 22. Suspension Bridge. 23. Beneset Bridge. A. Place du Palais. B. Place de l'Hôtel de Ville. C. Rue de la République. D. Rue Calade. E. Place du Corps Saint. G. Rue des Lices. H. Place Pia. J. Vieux Septier. K. Rue du Saule. L. Rue Carréeria. M. Porte du Rhône. N. Porte de la Ligne. O. Porte St Lazarus. Q. Porte L'Imbert. R. Forte St Michael. S. Porte St Roche. T. Porte de l'Oulle.

stretches in sombre grandeur along the southern slope. This building, or congeries of buildings, was commenced by Benedict XII. in 1336, and continued by successive popes for sixty years. It covers an area of rather more than 1½ acres. The paintings with which it was profusely adorned are in great measure destroyed, and even the grandeur of its dismantled interiors was for a long time broken in upon by the carpentry and plaster-work of French barracks. A restoration has, however, been for some time in progress; and the building will again be appropriated for ecclesiastical and civic purposes. The churches of St Agricoll, St Didier, and St Pierre may be mentioned as of some importance; also the papal mint, now known as a music academy; the town-hall, built in 1862; the Calvet museum, rich in Roman remains; the Requin museum of natural history; and the Hôtel des Invalides. Of the church of the Cordeliers, in which Petrarch's Laura was buried, only a small part is standing, and the tomb itself has been entirely destroyed. The city is the seat of an archbishop, and has tribunals of primary jurisdiction and commerce, a royal college, a theological seminary, a society of arts, the Vaucluse academy, a public library, a theatre, &c. The chief object of industry is the preparation of silk and the manufacture of silk goods; there are also manufactures of paper, leather, hats, jewellery, iron-ware &c. Avignon is remarkably subject to violent winds, of which the most disastrous is the *mistral*; and, according to the proverb, *Avenio ventosa, sine vento venenosa, cum vento fastidiosa* (windy Avignon, liable to plague when it has not the wind, and plagued with the wind when it has it). The town was a place of some importance in the times of Roman supremacy, and seems to have had some special connection with the Greek colony at Massilia. It was incorporated with the Burgundian kingdom, and on its dissolution became a free republic, after the Italian type. As late, indeed, as 1790, it retained its consuls, though its

republican constitution was really destroyed by Charles of Anjou. From 1309, when Clement V. took up his abode in the city, to 1377, when Gregory XI. returned to Rome, Avignon was the seat of the papal court, and it continued from 1378 to 1418 to be the seat of French anti-popes. In 1348 it was purchased by Pope Clement VI. from Joanna of Sicily for the sum of 80,000 florins, and it remained in possession of the popes till the French Revolution. Population in 1872, 38,196.

AVILA, a province of Spain, one of the modern divisions of the kingdom of Old Castile, situated between long. 4° 14' and 5° 55' W., and lat. 40° 48' and 41° 18' N. It is bounded on the N. by Valladolid, E. by Segovia and Madrid, S. by Toledo and Cáceres, and W. by Salamanca. The area is 2570 square miles; population, 176,769. It naturally divides itself into two sections, differing completely in soil, climate, productions, and social economy. The northern portion is generally level; the soil is of indifferent quality, strong and marly in a few places, but rocky in all the valleys of the Sierra de Avila; and the climate alternates from severe cold in winter to extreme heat in summer. The population of this part is agricultural. The southern division is one mass of rugged granitic *sierras*, interspersed, however, with sheltered and well-watered valleys, abounding with rich vegetation. The winter here, especially in the elevated region of the Paramera and the waste lands of Avila, is long and severe, but the climate is not unhealthy. The inhabitants are occupied in the rearing of cattle. The principal mountain-chains are the Guadarrama, separating this province from Madrid; the Sierras de Avila, a continuation of them westward; the Sierra de Gredos, running from the south of Piedrahita through Barco, Arenas, and part of Cebreros; and the Paramera, stretching southwards from the city of Avila into Arenas and Cebreros. The various ridges which ramify from the latter are covered with wood, presenting a striking contrast to the bare peaks of the Sierra de Gredos, and the barren levels in which they rise on the north. The principal rivers are the Alberche and Tietar, belonging to the basin of the Tagus, and the Tormes, the Corneja, and the Adaja, belonging to that of the Douro. The mountains contain silver, copper, iron, lead, and coal, but their mineral wealth has been exaggerated, and the actual production is absolutely nil. Quarries of fine marble and jasper exist in the district of Arenas. The province has declined in wealth and population during the last two centuries, a result due less to the want of activity on the part of the inhabitants than to the oppressive manorial and feudal rights and the strict laws of entail and mortmain, which have acted as barriers to improvement. The principal production is the wool of the Merino sheep, which at one time yielded an immense revenue. Game is plentiful, and the rivers abound in fish, specially trout. Olives, chestnuts, and grapes are grown, and the culture of silk-worms is also carried on. There is little trade, and the manufactures are few, consisting chiefly of copper utensils, lime, soap, cloth, paper, combs, &c. The state of elementary education is comparatively good, and the ratio of crime is proportionately low (*Madoz, Diccionario de España*).

AVILA (the ancient *Abula*), a city of Spain, the capital of the above province, is situated on the right bank of the Adaja, about 3000 feet above the sea-level, at the termination of the Guadarrama Mountains. "On all sides," says a recent traveller, "the town is surrounded by a tawny desert, over whose arid plains numbers of gray boulders are scattered like flocks of sheep." Its ancient wall is still in good preservation, crowned by a breastwork, with towers of great strength; but a large part of the town lies beyond the circuit. Avila is the seat of a bishop suffragan to Santiago, and has a Gothic cathedral, built by Garcia



de Estrella in 1107; a number of interesting churches, such as *Santo Tomas*, with the beautiful tomb of Prince Juan, *San Vincenti*, with its remarkable carving, and *Nuestra Señal. Madre Santa Teresa*, built over the birthplace of the patroness of Spain (who here founded the convent of St Joseph); as well as several monasteries and schools, an infirmary, and a foundling hospital. It was formerly the seat of a university, which was founded in 1482, and changed into the college of St Thomas in 1807. The only manufacture of any importance is the spinning of the wool furnished by the native sheep. Population, 6892.

AVILA, GIL GONZALEZ D', a Spanish biographer and antiquary, was born at Avila about the year 1577, and died there in 1658. He was made historiographer of Castile in 1612, and of the Indies in 1641. Of his numerous works, the most valuable are his *Teatro de las Grandezas de Madrid* (Madrid, 1623, *sqq.*), and his *Teatro Eclesiastico*, descriptive of the metropolitan churches and cathedrals of Castile, with lives of the prelates (Madrid, 1645-53, 4 vols. 4to).

AVILA Y ZUNIGA, LUIS D', author of a Spanish history of the wars of Charles V. Nothing is known as to the place or date either of his birth or of his death. He was probably of low origin, but married a wealthy heiress of the house of Zuniga, whose name he added to his own. He rose rapidly in the favour of the Emperor Charles V., served in the army and as ambassador to Rome, and was present at the funeral of Charles in 1558. His work is entitled *Comentarios de la Guerra de Alemania, hecha de Carlos V. en el año de 1546 y 1547*, and appears to have been printed in 1548. It became very popular, and was translated into English, French, Dutch, German, Italian, and Latin. As was to be expected from the position of the author, the book gave a rather one-sided account of Charles, and its misrepresentations have been severely criticised.

AVILES, SAN NICOLAS DE (the Latin *Flavionavia*), a town of Spain, in the province of Oviedo, about a league from the sea-coast, in lat. 43° 34' N., long. 5° 58' W. It has a considerable trade by means of its port, which affords good anchorage for all classes of vessels. There are here some copper works and coal mines, and the stone quarries are extensive and productive. Aviles has two parish churches, a theatre, and a public school. Population, 3297.

AVLONA, or VALONA (the ancient *Ἀβλὼν*), a town and seaport of Albania, in the eyalet of Yanina. It stands on an eminence near the Gulf of Avlona, an inlet of the Adriatic, almost surrounded by mountains. The port, which is protected by the island of Sesseno, the ancient Saso, is the best on the Albanian coast. It is visited weakly by Austrian steamers, and carries on considerable intercourse with Brindisi, &c. The town is about a mile and a half from the sea, and has rather a pleasant appearance with its minarets and its palace, surrounded with gardens and olive-groves. The Christian population, of which a considerable proportion are Italians, is largely engaged in commerce; while the Turks manufacture woollen stuffs and arms. The material imported into England for tanning, under the name of *Valonia*, is the pericarp of an acorn produced in the district. Avlona played an important part in the wars between the Normans and the Byzantine empire. In 1464 it was taken by the Ottomans; and after being in Venetian possession in 1690, was restored to them in 1691. In 1851 it suffered severely from an earthquake.

AVOIRDUPOIS, or AVREDUPOIS, the name of a system of weights, commonly supposed to be derived from the French, *avoir de pois*, to have weight. The suggested derivation from *averer*, to verify, seems, however, more probable, *averdupois* being the earlier form of the word.

Avoldupois weight is used for all commodities except the precious metals, gems, and medicines. The pound avoldupois, which is equal to 7000 grains troy; or 453.54 grammes, is divided into 16 ounces, and the ounce into 16 drams. See WEIGHTS AND MEASURES.

AVOLA, a city on the coast of Sicily, in the province of Syracuse, with 11,912 inhabitants. It manufactures straw-mats, and has trade in wine, grain, oil, honey, &c.; and there are sugar plantations.

AVON, the name of several rivers in England, Scotland, and France. The word is Celtic, appearing in Welsh as *afon*, in Manx as *con*, and in Gaelic as *abhainn* (pronounced *avain*), and is radically identical with the Sanskrit *ap*, water, and the Latin *agua* and *amnis*. The root appears more or less disguised in a vast number of river names all over the Celtic area in Europe. Thus, besides such forms as *Fean*, *Aune*, *Anne*, *Ive*, *Auney*, *Inney*, &c., in the British Islands, we have *Af* and *Aven* in Brittany, *Avenac* and *Avena* in Italy, *Avia* in Portugal, and *Avono* in Spain; while the terminal syllable of a large proportion of the French rivers, such as the *Sequana*, the *Matrona*, the *Garumna*, and so on, seems originally to have been the same word. The names Punjab, Doab, &c., show the root in a clearer shape. (See Taylor's *Words and Places*.) Of the principal English rivers of this name in its full form three belong to the basin of the Severn. The Upper or Shakespearean Avon, rising in Northamptonshire, near the battlefield of Naseby, flows through Warwickshire, Worcester, and Gloucester, past Rugby, Warwick, Stratford, and Evesham, and joins the larger river at Tewkesbury; while the Lower Avon has its sources on the borders of Wiltshire, and enters the estuary of the Severn at King's Roads, after passing Malmesbury, Bath, and Bristol. (See Ireland's *Upper Avon*; Lewis's *Book of English Rivers*, 1855.) The Middle or Little Avon has its whole course in Gloucestershire, and reaches the Severn a short distance below the town of Berkeley. Another river of this name rises in Wilt, and flows past Salisbury to the British Channel. In Scotland one is a tributary of the Clyde, another belongs to the basin of the Forth, and a third joins its waters with the Annan, while an *Aven* is a confluent of the Spey. In France there are two "Avona" in the system of the Loire, and two in that of the Seine.

AVRANCHES (ancient *Abrincata*, or *Ingena*), a town of France, in the department of Manche. It was an important military station of the Romans, and has in more modern times sustained several sieges, the most noticeable of which was the result of its opposition to Henry IV. It stands on a wooded hill, commanding a fine view of the bay and rock of St Michel, about three miles distant. At the foot of the hill flows the river Sée, which at high tide is navigable from the sea. The principal trade is in corn, cider, and salt; and candles, lace, nails, parchment, leather, &c., are manufactured. Avranches was formerly a bishop's see; and its cathedral, destroyed as insecure in the time of the first French Revolution, was the finest in Normandy. Its site is now occupied by an open place, called after the celebrated Huet, bishop of Avranches; and one stone remains with an inscription marking it out as the spot where Henry II. received absolution for the murder of A. Becket, Saint-Saturnin's church dates from the 13th century, and has a remarkable gateway. The ancient episcopal palace is now used as a museum of antiquities; and an extensive public library is kept in the "mairie." A new cathedral is in course of erection. The agreeable situation and climate of this town make it a favourite residence of English families. Population in 1872, 8137.

AXHOLM, or AXHOLMA, an island in the N.W. part of Lincolnshire, England, formed by the rivers Trent, Idle, and Don. It consists mainly of a plateau of slight elevation,

and comprises the parishes of Althorpe, Belton, Epworth, Hazey, Luddington, Owston, and Crowle; the total area being about 40,000 acres. At a very early period it would appear to have been covered with forest; but this having been in great measure destroyed, it sank into a comparative swamp. In 1627 King Charles I., who was lord of the island, entered into a contract with Cornelius Vermuyden, a Dutchman, for reclaiming the meres and marshes, and rendering them fit for tillage. This undertaking led to the introduction of a large number of Flemish workmen, who settled in the district, and, in spite of the violent measures adopted by the English peasantry to expel them, retained their ground in sufficient numbers to affect the physical appearance and the accent of the inhabitants to this day. Elaborate volumes have been published on the island by Peck (1815), Stonehouse, and Read. (See paper, by E. Peacock, in *Anthropological Review*, 1870.)

AXIOM, from the Greek *ἀξίωμα*, is a word of great import both in general philosophy and in special science; it also has passed into the language of common life, being applied to any assertion of the truth of which the speaker happens to have a strong conviction, or which is put forward as beyond question. The scientific use of the word is most familiar in mathematics, where it is customary to lay down, under the name of axioms, a number of propositions of which no proof is given or considered necessary, though the reason for such procedure may not be the same in every case, and in the same case may be variously understood by different minds. Thus scientific axioms, mathematical or other, are sometimes held to carry with them an inherent authority or to be self-evident, wherein it is, strictly speaking, implied that they cannot be made the subject of formal proof; sometimes they are held to admit of proof, but not within the particular science in which they are advanced as principles; while, again, sometimes the name of axiom is given to propositions that admit of proof within the science, but so evidently that they may be straightway assumed. Axioms that are genuine principles, though raised above discussion within the science, are not therefore raised above discussion altogether. From the time of Aristotle it has been claimed for general or first philosophy to deal with the principles of special science, and hence have arisen the questions concerning the nature and origin of axioms so much debated among the philosophic schools. Besides, the general philosopher himself, having to treat of human knowledge and its conditions as his particular subject-matter, is called to determine the principles of certitude, which, as there can be none higher, must have in a peculiar sense that character of ultimate authority (however explicable) that is ascribed to axioms; and by this name, accordingly, such highest principles of knowledge have long been called. In the case of a word so variously employed there is, perhaps, no better way of understanding its proper signification than by considering it first in the historical light—not to say that there hangs about the origin and early use of the name an obscurity which it is of importance to dispell.

The earliest use of the word in a logical sense appears in the works of Aristotle, though, as will presently be shown, it had probably acquired such a meaning before his time, and only received from him a more exact determination. In his theory of demonstration, set forth in the *Posterior Analytics*, he gives the name of axiom to that immediate principle of syllogistic reasoning which a learner must bring with him (i. 2, 6); again, axioms are said to be the common principles from which all demonstration takes place—common to all demonstrative sciences, but varying in expression according to the subject-matter of each (i. 10, 4). The principle of all other axioms—the surest of all principles—is that called later the principle of Contradiction, in-

demonstrable itself, and thus fitted to be the ground of all demonstration (*Metaph.*, iii. 2, iv. 3). Aristotle's followers, and, later on, the commentators, with glosses of their own, repeat his statements. Thus, according to Themistius (*ad Post. Anal.*), two species of axioms were distinguished by Theophrastus—one species holding of all things absolutely, as the principle (later known by the name) of Excluded Middle, the other of all things of the same kind, as that the remainders of equals are equal. These, adds Themistius himself, are, as it were, connate and common to all, and hence their name Axiom; "for what is put over either all things absolutely or things of one sort universally, we consider to have precedence with respect to them." The same view of the origin of the name reappears in Boethius's Latin substitutes for it—*dignitas* and *maxima* (*propositio*), the latter preserved in the word Maxim, which is often used interchangeably with Axiom. In Aristotle, however, there is no suggestion of such a meaning. As the verb *ἀξίω* changes its original meaning of *deem worthy* into *think fit*, *think simply*, and also *claim* or *require*, it might as well be maintained that *ἀξίωμα*—which Aristotle himself employs in its original ethical sense of *worth*, also in the secondary senses of *opinion* or *dictum* (*Metaph.*; iii. 4), and of simple *proposition* (*Topica*, viii. 1)—was conferred upon the highest principles of reasoning and science because the teacher might require them to be granted by the learner. In point of fact, later writers, like Proclus and others quoted by him, did attach to Axiom this particular meaning, bringing it into relation with Postulate (*ἀίρημα*), as defined by Aristotle in the *Posterior Analytics*, or as understood by Euclid in his *Elements*. It may here be added that the word was used regularly in the sense of bare *proposition* by the Stoics (*Diog. Laert.*, vii. 65, though Simplicius curiously asserts the contrary, *ad Epict. Ench.*, c. 58), herein followed in later times by the Ramist logicians, and also, in effect, by Bacon.

That Aristotle did not originate the use of the term axiom in the sense of scientific first principle, is the natural conclusion to be drawn from the reference he makes to "what are called axioms in mathematics" (*Metaph.*, iv. 3). Sir William Hamilton (Note A, Reid's *Works*, p. 765) would have it that the reference is to mathematical works of his own now lost, but there is no real ground for such a supposition. True though it be, as Hamilton urges, that the so-called axioms standing at the head of Euclid's *Elements* acquired the name through the influence of the Aristotelian philosophy, evidence is not wanting that by the time of Aristotle, a generation or more before Euclid, it was already the habit of geometers to give definite expression to certain fixed principles as the basis of their science. Aristotle himself is the authority for this assertion, when, in his treatise *De Caelo*, iii. 4, he speaks of the advantage of having definite principles of demonstration, and these as few as possible, such as are postulated by mathematicians (*καθ' ἕνα ἀξίωμα καὶ οἱ ἐν τοῖς μαθηματικῶν*), who always have their principles limited in kind or number. The passage is decisive on the point of general mathematical usage, and so distinctly suggests the very word axiom in the sense of a principle assumed or postulated, that Aristotle's repeated instance of what he himself calls by the name—if equals be taken from equals, the remainders are equal—can hardly be regarded otherwise than as a citation from recognised mathematical treatises. The conclusion, if warranted, is of no small interest, in view of the famous list of principles set out by Euclid, which has come to be regarded in modern times as the typical specimen of axiomatic foundation for a science.

Euclid, giving systematic form to the elements of geometrical science in the generation after the death of Aristotle,

propounded, at the beginning of his treatise, under the name of *dogmata*, the definitions with which modern readers are familiar; under the name of *akrivmata*, the three principles of construction now called postulates, together with the three theoretic principles, specially geometrical, now printed as the tenth, eleventh, and twelfth axioms; finally, under the name of *κοινὰ ἐπιπέδα*, or common notions, the series of general assertions concerning equality and inequality, having an application to discrete as well as continuous quantity, now printed as the first nine axioms. Now, throughout the *Elements*, there are numerous indications that Euclid could not have been acquainted with the logical doctrines of Aristotle: a most important one has been signalised in the article ANALYSIS, and, in general, it may suffice to point out that Euclid, who is said to have flourished at Alexandria from 323 (the year of Aristotle's death) to 283 B.C., lived too early to be affected by Aristotle's work—all the more that he was, by philosophical profession, a Platonist. Yet, although Euclid's disposition of geometrical principles at the beginning of his *Elements* is itself one among the signs of his ignorance of Aristotle's logic, it would seem that he had in view a distinction between his postulates and common notions not unlike the Aristotelian distinction between *akrivmata* and *ἀξιόματα*. All the postulates of Euclid (including the last three so-called axioms) may be brought under Aristotle's description of *akrivmata*—principles concerning which the learner has, to begin with, neither belief nor disbelief, *Post. Anal.*, i. 10, 6; being (as De Morgan interprets Euclid's meaning) such as the "reader must grant or seek another system, whatever be his opinion as to the propriety of the assumption." Still closer to the Aristotelian conception of axioms come Euclid's common notions, as principles "which there is no question every one will grant" (De Morgan). From this point of view, the composition of Euclid's two lists, as they originally stood, becomes intelligible: be this, however, as it may, there is evidence that his enumeration and division of principles were very early subjected to criticism by his followers with more or less reference to Aristotle's doctrine. Apollonius (260-220 B.C.) is mentioned by Proclus (*Com. in Eucl.*, iii.) as having sought to give demonstrations of the common notions under the name of axioms. Further, according to Proclus, Geminus made the distinction between postulates and axioms which has become the familiar one, that they are indemonstrable principles of construction and demonstration respectively. Proclus himself (412-485 A.D.) practically comes to rest in this distinction, and accordingly extrudes from the list of postulates all but the three received in modern times. The list of axioms he reduces to five, striking out as derivative the two that assert inequality (4th and 5th), also the two that assert equality between the doubles and halves of the same respectively (6th and 7th). Euclid's postulate regarding the equality of right angles and the other assumed in the doctrine of parallel lines, now printed as the 11th and 12th axioms, he holds to be demonstrable: the 10th axiom (regarded as an axiom, not a postulate, by some ancient authorities, and so cited by Proclus himself)—Two straight lines cannot enclose a space—he refuses to print with the others, as being a special principle of geometry. Thus he restricts the name axiom to such principles of demonstration as are common to the science of quantity generally. These, he then declares, are principles immediate and self-manifest—untaught anticipations whose truth is darkened rather than cleared by attempts to demonstrate them.

The question as to the axiomatic principles, whether of knowledge in general or of special science, remained where it had thus been left by the ancients till modern times, when new advances began to be made in positive scientific inquiry and a new philosophy took the place of the per-

ipatetic system, as it had been continued through the Middle Ages. It was characteristic alike of the philosophic and of the various scientific movements begun by Descartes to be guided by a consideration of mathematical method—that method which had led in ancient times to special conclusions of exceptional certainty, and which showed itself, as soon as it was seriously taken up again, more fruitful than ever in new results. To establish philosophical and all special truth after the model of mathematics became the direct object of the new school of thought and inquiry, and the first step thither consisted in positing principles of immediate certainty whence deduction might proceed. Descartes accordingly devised his criterion of perfect clearness and distinctness of thought for the determination of ultimate objective truth, and his followers, if not himself, adopted the ancient word axiom for the principles which, with the help of the criterion, they proceeded freely to excogitate. About the same time the authority of all general principles began to be considered more explicitly in the light of their origin. Not that ever such consideration had been wholly overlooked, for, on the contrary, Aristotle, in pronouncing the principles of demonstration to be themselves indemonstrable, had suggested, however obscurely, a theory of their development, and his followers, having obscure sayings to interpret, had been left free to take different sides on the question; but, as undoubtedly the philosophic investigation of knowledge has in the modern period become more and more an inquiry into its genesis, it was inevitable that principles claiming to be axiomatic should have their pretensions scanned from this point of view with closer vision than ever before. Locke it was who, when the Cartesian movement was well advanced, more especially gave this direction to modern philosophic thought, turning attention in particular upon the character of axioms; nor was his original impulse weakened—rather it was greatly strengthened—by his followers' substitution of positive psychological research for his method of general criticism. The expressly critical inquiry undertaken by Kant, at however different a level, had a like bearing on the question as to the nature of axiomatic principles; and thus it has come to pass that the chief philosophic interest now attached to them turns upon the point whether or not they have their origin in experience.

It is maintained, on the one hand, that axioms, like other general propositions, result from an elaboration of particular experiences, and that, if they possess an exceptional certainty, the ground of this is to be sought in the character of the experiences, as that they are exceptionally simple, frequent, and uniform. On the other hand, it is held that the special certainty, amounting, as it does, to positive necessity, is what no experience, under any circumstances, can explain, but is conditioned by the nature of human reason. More it is hardly possible to assert generally concerning the position of the rival schools of thought, for on each side the representative thinkers differ greatly in the details of their explanation, and there is, moreover, on both sides much difference of opinion as to the scope of the question. Thus Kant would limit the application of the name axiom to principles of mathematical science, denying that in philosophy (whether metaphysical or natural), which works with discursive concepts, not with intuitions, there can be any principles immediately certain; and, as a matter of fact, it is to mathematical principles only that the name is universally accorded in the language of special science—not generally, in spite of Newton's lead, to the laws of motion, and hardly ever to scientific principles of more special range like the atomic theory. Other thinkers, however, notably Leibnitz, lay stress on the ultimate principles of all thinking as the only true axioms, and would

contend for the possibility of reducing to these (with the help of definitions) the special principles of mathematics, commonly allowed to pass and do duty as axiomatic. Still others apply the name equally and in the same sense to the general principles of thought and to some principles of special science. In view of such differences of opinion as to the actual matter in question, it is not to be expected that there should be agreement as to the marks characteristic of axioms, nor surprising that agreement, where it appears to exist, should often be only verbal. The character of necessity, for example, so much relied upon for excluding the possibility of an experiential origin, may either, as by Kant, be carefully limited to that which can be claimed for propositions that are at the same time synthetic, or may be vaguely taken (as too frequently by Leibnitz) to cover necessity of mere logical implication—the necessity of analytic, including identical, propositions—which Kant allowed to be quite consistent with origin in experience. The question being so perplexed, no other course seems open than to try to determine the nature of axioms mainly upon such instances as are, at least practically, admitted by all, and these are mathematical principles.

That propositions with an exceptional character of certainty are assumed in mathematical science is notorious; that such propositions must be assumed as principles of the science, if it is to be at once general and demonstrative, is now conceded even by extreme experientialists; while it is, farther, universally held that it is the exceptional character of the subject-matter of mathematics that renders possible such determinate assumption. What the actual principles to be assumed are, has, indeed, always been more or less disputed; but this is a point of secondary importance, since it is possible from different sets of assumption to arrive at results practically the same. The particular list of propositions passing current in modern times as Euclid's axioms, like his original list of common notions, is open to objection, not so much for mixing up assertions not equally underivative (as the ancient critics remarked), but for including two—the 8th and 9th—which are unlike all the others in being mere definitions (*viz.*, of equals and of whole or part). Being intended as a body of principles of geometry in particular within the general science of mathematics, the modern list is not open to exception in that it adds to the propositions of general mathematical import, forming Euclid's original list, others specially geometrical, provided the additions made are sufficient for the purpose. It does, in any case, contain what may be taken as good representative instances of mathematical axioms both general and special; for example, the 1st, Things equal to the same are equal to one another, applicable to all quantity; and the 10th, Two straight lines cannot enclose a space, specially geometrical. (The latter has been regarded by some writers as either a mere definition of straight lines, or as contained by direct implication in the definition; but incorrectly. If it is held to be a definition, nothing is too complex to be so called, and the very meaning of a definition as a principle of science is abandoned; while, if it is held to be a logical implication of the definition, the whole science of geometry may as well be pronounced a congeries of analytic propositions. When straight line is strictly defined, the assertion is clearly seen to be synthetic.) Now of such propositions as the two just quoted it is commonly said that they are self-evident, that they are seen to be true as soon as stated, that their opposites are inconceivable; and the expressions are not too strong as descriptive of the peculiar certainty pertaining to them. Nothing, however, is thereby settled as to the ground of the certainty, which is the real point in dispute between the experiential and rational schools, as these have become determinately opposed since the time and

mainly through the influence of Kant. Such axioms, according to Kant, being necessary as well as synthetic, cannot be got from experience, but depend on the nature of the knowing faculty; being immediately synthetic, they are not thought discursively but apprehended by way of direct intuition. According to the experientialists, as represented by J. S. Mill, they are, for all their certainty, inductive generalisations from particular experiences; only the experiences are peculiar (as already said) in being extremely simple and uniform, while the experience of space—Mill does not urge the like point as regards number—is farther to be distinguished from common physical experience in that it supplies matter for induction no less in the imaginative (representative) than in the presentative form. Mill thus agrees with Kant on a vital point in holding the axioms to be synthetic propositions, but takes little or no account of that which, in Kant's eyes, is their distinctive characteristic—their validity as universal truths in the guise of direct intuitions or singular acts of perception, presentative or representative. The synthesis of subject and predicate, thus universally valid though immediately effected, Kant explains by supposing the singular presentation or representation to be wholly determined from within through the mind's spontaneous act, instead of being received as sensible experience from without; to speak more precisely, he refers the apprehension of quantity, whether continuous or discrete, to "productive imagination," and regards it always as a pure mental construction. Mill, who supposes all experiences alike to be passively received, or, at all events, makes no distinction in point of original apprehension between quantity and physical qualities, fails to explain what must be allowed as the specific character of mathematical axioms. Our conviction of their truth cannot be said to depend upon the amount of supporting experience, for increased experience (which is all that Mill secures and secures only for figured magnitude, without psychological reason given) does not make it stronger; and, if they are conceded on being merely stated, which, unless they are held to be analytic propositions, amounts to their being granted upon direct inspection of a particular case, it can be only because the case, so decisive, is made and not found—is constituted or constructed by ourselves, as Kant maintains, with the guarantee for uniformity and adequacy which direct construction alone gives. Still it does not therefore follow that the construction whereby synthesis of subject and predicate is directly made is of the nature described by Kant—due to the activity of the pure *ego*, opposed to the very notion of sensible experience, and absolutely *a priori*. As we have a natural psychological experience of sensations passively received through bodily organs, we also have what is not less a natural psychological experience of motor activity exerted through the muscular system. Only by muscular movements, of which we are conscious in the act of performing them, have we perception of objects as extended and figured, and in itself the activity of the describing and circumscribing movements is as much matter of experience as is the accompanying content of passive sensation. At the same time, the conditions of the active exertion and of the passive affection are profoundly different. While, in objective perception, within the same or similar movements, the content of passive sensation may indefinitely vary beyond any control of ours, it is at all times in our power to describe forms by actual movement with or without a content of sensation, still more by represented or imagined movement. Our knowledge of the physical qualities of objects thus becomes a reproduction of our manifold sensible experience, as this in its variety can alone be reproduced, by way of general concepts; our knowledge of their mathematical attributes is, first

and last, an act of conscious production or construction. It is manifestly so, as movement actual or imaginary, in the case of magnitude or continuous quantity; nor is it otherwise in the case of number or discrete quantity, when the units are objects (points or anything else) standing apart from each other in space. When the units are not objects presented to the senses or represented as coexistent in space, but are mere subjective occurrences succeeding each other in time, the numerical synthesis, doubtless, proceeds differently, but it is still an act of construction, dependent on the power we have of voluntarily determining the flow of subjective consciousness. Thus acting constructively in our experience both of number and form, we, in a manner, *make* the ultimate relations of both to be what for us they must be in all circumstances, and such relations when expressed are truly axiomatic in every sense that has been ascribed to the name.

Beyond the mathematical principles which may be thus accounted for, there are, as was before remarked, no other principles of special science to which the name of axiom is uniformly applied. It may now be understood why the name should be withheld from such a fundamental generalisation as the atomic theory in chemistry, even when we have become so familiar with the facts as to seem to see clearly that the various kinds of matter must combine with each other regularly in definite proportions: the proposition answers to no intuition or direct apprehension. At most could it be called axiomatic in the sense, of course applicable to mathematical principles also, that it is assumed as true in the body of science compacted by means of it. The laws of motion, however, formulated by Newton as principles of general physics, not only were called by him axiomatic in this latter sense, but have been given out by others since his time as propositions intuitively certain; and, though it cannot seriously be pretended that there is the same case for ascribing to them the character of *a priori* truths, there must be some reason why the name of axiom in the full sense has been claimed for them alone by the side of the mathematical principles. The *a priori* character, it is clear, can only in a peculiar sense be claimed for truths which all the genius of the ancients failed to grasp, and which were established in far later times as inductions from actual experiments; Newton, certainly, in calling them axioms, by no means claimed for them aught but an experiential origin. On the other hand, it must be conceded that motion as an experience has in it a character of simplicity, like that belonging to number and form, consisting mainly in a clear apprehension of the circumstances under which the phenomenon varies, while, again, such apprehension is conditioned by the psychological nature of the experience, namely, that it is one depending on activity of our own which we can control, and does not come to us as bare passive affection which we must take as we find it. We do in truth make or constitute motion, as we construct number and space; moving, as we please, without external occasion, and, when apprehending objective movements, following these with conscious motions of our members. Notwithstanding, our proper motions far less adequately correspond to the reality of external motions than do our subjective constructions of space and number answer to the reality of things figured and numbered. With limited store of nervous energy and muscles of confined sweep, we cannot execute at all such continued unvarying movements as occur, at least approximately, in nature; we cannot, by any such combinations of movements as we are able to make, determine beforehand the result of such complex motions as nature in endless variety exhibits; nor, again, can we with any accuracy appreciate the relation between action and reaction by opposing our muscular organs to one another. We must wait long upon

experience that comes to us, or rather, in face of the objective complexity presented by nature, sally forth to make varied experiments with moving things, and thereupon generalise, before anything can be determined positively respecting motion. This is precisely what inquirers, until about the time of Galileo, were by no means content to do, and they had accordingly laws of motion which were, indeed, devised *a priori*, but which were not objectively true. Since the time of Galileo true, or at least effective, laws of motion have been established inductively, like all other physical laws; only it is more easy than in the case of the others, which are less simple, to come near to an adequate subjective construction of them, and hence the claim sometimes set up for them to be in fact *a priori* and in the full sense axiomatic.

It remains to inquire in what sense the general principles of all knowledge or principles of certitude may be called, as they often are called, axioms. The laws of Contradiction and of Excluded Middle, noted though not named by Aristotle, together with that formulated as the law of Identity, presupposed as they are in all consistent thinking, have, with a character of widest generality, also a character of extreme simplicity, and may fitly be denominated axioms in the sense of immediate principles. They stand, however, as pure logical principles, apart from all others, being wholly formal, without a shade of material content. There can be no question, therefore, of their certainty being guaranteed by a direct intuition, valid for all cases because fully representative of all; as little does there appear valid ground for calling them, in the proper sense, inductive generalisations from experience. They may rather be held to admit only of the kind of proof that Aristotle calls dialectical: whoever denies them will find that he cannot argue at all or be argued with; he cuts himself off from all part in rational discourse, and is no better, as Aristotle forcibly expresses it, than a plant. The like position of being postulated as the condition of making progress belongs to the very different principle or principles (which may, however, be called logical, in the wider sense) implied in the establishment of truth of fact, more particularly the inductive investigation of nature. Whether expressed in the form of a principle of Sufficient Reason, as by Leibnitz, or, as is now more common, in the form of a principle of Uniformity of Nature, with or without a pendant principle of Causality for the special class of uniformities of succession, some assumption is indispensable for knitting together into general truths the discrete and particular elements of experience. Such postulates must be declared to have an experiential origin rather than to be *a priori* principles, but experience may more truly be said to suggest them than to be their ground or foundation, since they are themselves the ground, express or implied, of all ordered experience. Their case is perhaps best met by pronouncing them hypothetical principles, and as there are no axioms—not even those of mathematics—that are thought of without reference to their proved efficiency as principles leading to definite conclusions, they may be called axiomatic on account of their extreme generality, however little they possess the character of immediacy.

The name axiom, at the end of the inquiry, is thus left undeniably equivocal, and it clearly behoves those who employ it, whether in philosophy or science, always to make plain in what sense it is meant to be taken. Before closing, it is, perhaps, necessary to add why, in dealing with the question of origin, no account has been taken of the doctrine of evolution which has become so prominent in the latest scientific and philosophical speculation. From the point of view of the present article, that doctrine has only an indirect bearing on the inquiry. If the conditions of experience as they are found in the

individual suffice to explain the different assurance with which general assertions are made in different departments of knowledge, there is no need to carry the psychological consideration farther back. The effect of such difference in the conditions of experience may, of course, be accumulated in the life of the race, and the accumulation may go far to determine the psychological history of the individual, but the question, as a rational one, must be decided upon analysis of the conditions as they are. (G. C. R.)

**AXMINSTER**, a market-town of England, in the county of Devon, 147 miles from London, and 24 from Exeter. It takes its name from the River Axe, on which it stands. The ancient abbey-church, or minster, which adorns the centre of the town, was built by King Athelstan to commemorate a victory over the Danes. The town was formerly distinguished for its production of the best and most costly description of carpets; and it still manufactures broad and narrow cloths, cotton, leather, gloves, tapes, and druggets. Dr Buckland was a native of the town. Population of the parish in 1871, 2861.

**AXUM**, an ancient city of Abyssinia, 85 miles N.W. of Antalo, still remarkable for its ruins. It was for a long time the capital of a great Shemitic people, who extended their sway over a large part of Abyssinia; and the language spoken there at the time of the introduction of Christianity has continued to be the ecclesiastical language ever since. The chronicles of Abyssinia were preserved in the church, and are frequently referred to as the *Books of Axum*. The most interesting of the monuments still extant are the obelisk and the so-called coronation-room, both constructed of granite, and the latter containing some valuable bilingual inscriptions. In the modern town, which is the capital of the kingdom of Tigré, the weaving of cotton and manufacture of parchment are carried on. (See Salt's *Travels*, and Schimper in *Zeitsch. der Ges. Erdk.*, Berlin, 1869.)

**AYAMONTE**, a fortified city of Spain, in the province of Huelva, on the left bank of the Guadiana, about 2 miles from its mouth. The harbour is good, but, on account of a bar at its mouth, it is of difficult entrance. The principal employment of the inhabitants is afforded by the fisheries, especially for sardines, tunny, cod, and horse-mackerel; but this branch of industry has suffered by the extension of the general coasting traffic. Silk-weaving is carried on. Ayamonte is said to have had in the 16th century 16,000 inhabitants. Population, 5960.

**AYLESBURY**, a market-town, parliamentary borough, and railway junction, in the county of Buckingham, 39 miles N.W. of London. It stands on a gentle eminence in the centre of a fertile vale, and consists of several streets and lanes irregularly built, but well paved and lighted. The county-hall, market-house, and county gaol are handsome buildings, as is also the parish church, an ancient structure with a tower rising from the centre. It has a free grammar-school (1611), several other schools and charities, a corn-exchange (1865), three banks, a savings bank, an infirmary (1833), a union workhouse, and places of public worship for Roman Catholics, Methodists, Baptists, Independents, &c. It returns two members to parliament. The assizes and quarter sessions and the elections of members for the county are held here. The inhabitants are principally employed in the manufacture of bouelace and straw-plaiting, besides the rearing of ducks, which are sent in large quantities to the London market at Christmas. A branch canal, six miles in length, connects Aylesbury with the Grand Junction Canal. Population of parliamentary borough in 1871, 28,760.

**AYLESFORD**, a village of England, in the county of Kent, 3½ miles from Maidstone, and 32 from London. It stands at the base of a hill on the right bank of the

Medway, which is here crossed by a stone bridge of six arches. The church stands on an eminence behind the village. At a short distance to the W. was a Carmelite friary, founded in 1240, the remains of which now form a part of the family mansion of the earl of Aylesford. The vicinity exhibits several remains of antiquity, among which is, or rather was, for it is grievously destroyed, a cromlech called Kit's Coity House, about a mile N.E. from the village. This is supposed by Mr Fergusson, in accordance with tradition, to mark the burial-place of Catigern, who was slain here in a battle between the Britons and Saxons in 455 A.D. The tomb of Horsa, who fell in the same battle, is situated at Horsted, about 2 miles to the N. Near Aylesford, too, are other remains, known as the Countless Stones. Population of parish in 1871, 2100.

**AYLMER**, JOHN, Bishop of London in the reign of Queen Elizabeth, was born in the year 1521 at Aylmer-hall, in the parish of Tilney, in the county of Norfolk. Whilst a boy, he was noticed for his precocity by the marquis of Dorset, afterwards duke of Suffolk, who sent him to the university of Cambridge. He afterwards proceeded to Oxford, where he completed his studies and took his degree in divinity. He was then made chaplain to the duke and tutor to his daughter, the accomplished and unfortunate Lady Jane Grey, whose extraordinary proficiency in the Greek and Latin languages reflects no small honour on her preceptor. His first preferment was to the archdeaconry of Stow, in the diocese of Lincoln, which gave him a seat in the Convocation held in the first year of Queen Mary, where he resolutely opposed the return to Popery, to which the generality of the clergy were inclined. He was soon after obliged to fly his country, and take shelter among the Protestants in Switzerland. While there he wrote a reply to Knox's famous *Blast against the Monstrous Regiment of Women*, under the title of *An Harboure for Faithfull and Trewe Subjects*, &c. On the accession of Queen Elizabeth he returned to England. In 1562 he obtained the archdeaconry of Lincoln, and was a member of the famous synod of that year, which reformed and settled the doctrine and discipline of the Church of England. In 1576 he was consecrated bishop of London, and while in that position made himself notorious by the harsh manner in which he insisted on the Act of Uniformity. His persecution of the Puritans, and of any clergymen suspected of Puritanical leanings, with the extreme measures he used, made him unpopular even with his own party. He is frequently assailed in the famous *Marporetate Tracts*, and is characterised as *Morrell*, the bad shepherd, in Spenser's *Shepherd's Calendar*. He seems to have been a man of harsh and violent temper, coarse, and avaricious, and with few redeeming qualities. He is said to have been an able scholar, but he has left nothing which could prove this. He died in 1594. (Strype, *Life and Actions of John Aylmer, Bishop of London*.)

**AYR**, COUNTY OF, or **AYRESHIRE**, a Scottish county, bounded by Wigtownshire and the stewartry of Kirkcubright on the S.; by Kirkcubright, Dumfries, and Lanark on the E.; and by Renfrewshire on the N. On the W. it has a coast line extending to 70 miles on the Irish Sea and the Firth of Clyde. The county contains 1149 square miles, or 735,262 acres. The middle part, which is the broadest, is about 26 miles across. There are six rivers of some note in Ayrshire—Stinchar, Girvan, Doon, Ayr, Irvine, and Garnock. Of these the Ayr, from which the county and county town take their name, is the largest. It rises at Glenbuck, on the border of Lanarkshire, and, after a course of 33 miles, falls into the Firth of Clyde at the county town. The scenery along its banks from Sorn downwards—passing Catrine, Ballochmyle, Barakim-

ming, Sundrum, Auchencruive, and Craigie—is varied and beautiful. The lesser streams are numerous; and there are many fresh-water lochs, the largest of which is Loch Doon, the source of the river Doon. The southern and eastern parts of the county are hilly, but none of the peaks reaches a height of 2000 feet. In former times the shire was divided into three districts—Carrick, south of the Doon; Kyle, between the Doon and the Irvine; and Cunningham, north of the Irvine. Kyle, again, was divided by the river Ayr into King's Kyle on the south, and Kyle Stewart on the north. The county is now politically divided into south and north Ayrshire. The former comprises Kyle and Carrick, and the latter Cunningham, and each division returns a representative to Parliament. The old divisions, however are still popularly retained. The greater part of Carrick is hilly, and fit only for sheep-walks. The uplands of Kyle are also extensive, but there is a larger proportion of good low-country land in that district. Cunningham is comparatively level, and has a great extent of rich land, though rather heavy in its character. The scenery is not grand in any part of the county, but much of it is picturesque and beautiful. From many of the heights a rich, undulating, well-wooded country may be seen, with the Bay of Ayr, or the Firth of Clyde beyond, and the lofty peaks of Arran, or the Argyllshire hills, in the distance.

There has been no lack of agricultural enterprise in Ayrshire. With a moist climate, and, generally, a rather heavy soil, draining was necessary for the successful growth of green crops. Up till 1840, or a few years later, a green crop in the rotation was seldom seen, except on porous river-side land, or on the lighter farms of the lower districts. In the early part of the century lime was a powerful auxiliary in the inland districts, but, with repeated applications, it gradually became of little avail. Thorough draining gave the next great impulse to agriculture. Enough had been done to test its efficacy previous to the announcement of Sir Robert Peel's drainage loan, after which it was rapidly extended throughout the county. Green-crop husbandry, and the liberal use of guano and other auxiliary manures, made a wonderful change on the face of the county, and increased immensely the amount of agricultural produce. Early potatoes are now extensively grown in some localities. The farmers on the coast lands of Girvan and West Kilbride are first in the market, and the next supplies come from the friable lands about Ayr and St Quivox. A considerable extent of ground is cleared in June for the Glasgow market; and, in dropping seasons, good crops of turnips follow. At the end of July and the beginning of August, great quantities of potatoes are sent to Newcastle, and to the large towns of Lancashire and the West Riding. The mild climate of the Ayrshire coast in spring is favourable to this kind of cropping, which brings quick returns, and on the whole is profitable. Carrots and mangolds are cultivated more extensively than in any other Scotch county, and, with early sowing and rich manuring, heavy crops are raised. Wheat generally follows green crops in the lower parts of the county, though barley is coming more into use than in former times on light land. The border line for wheat may be drawn at a little over 300 feet; above that height its growth is exceptional. The dairy forms an important department of farm management in Ayrshire. Dunlop cheese was a well-known product of Ayrshire dairies a quarter of a century ago. Part of it was very good; but it was unequal in its general character, and unsaleable in English markets. Dissatisfied with the inferior commercial value of their cheese in comparison with some English varieties, the Ayrshire Agricultural Association brought a Somerset farmer and his wife in 1855 to teach the Cheddar method, and their

effort has been most successful. Cheddar cheese of first rate quality is now made in Ayrshire and Galloway, and the annual cheese show at Kilmarnock is the most important in the kingdom. The cheese may be more thoroughly fine in a few Somerset dairies, but the average quality of Scotch Cheddar is higher than the English. This great change of an industrial art has brought wealth to the county. It is not too much to say that it has added £2 per cow to the annual value of dairy produce, and there are 45,000 cows in Ayrshire.

The manufactures of Ayrshire have attained considerable importance. The cotton works at Catrine are extensive, and have been a long time established. The site was chosen with the view of utilising the water power of the river Ayr, and steam is still merely an auxiliary. At Kilmarnock and Ayr there are extensive engineering establishments, and large carpet works; and other fabrics are manufactured in those towns and at Dalry, Kilbirnie, Beith, and Stewarton. Until the last three or four years, Irvine was a back-going place, but it has received an impulse from the erection of large chemical works. The situation is very suitable for chemical manufactures, as the soil is poor and sandy, and the liquid refuse of chemical works is easily carried into the sea, without causing the nuisance which is inevitable in a large town. The Eglinton Chemical Company are most extensive manufacturers of bichromate of potash—a substance which is used at dyeworks as an oxidising agent; and another company is largely engaged in the alkali trade, and in the extraction of copper from burnt pyrites ore. On the coast, between Irvine and Ardrossan, works have been erected on the sandhills for the manufacture of dynamite, which is now well known as one of the most powerful explosive agents. It is much used for blasting under water, and large quantities of it are sent to America for blowing up the roots of trees in the reclamation of land.

The iron trade of Ayrshire has risen to great importance. The manufacture has long been carried on at Muirkirk, although the iron had to be carted long distances to Ayr and Glasgow before the introduction of railways. Immense fields of ironstone have been opened up within the last quarter of a century; and there are now 33 furnaces in blast within the county, producing about 330,000 tons per annum. The works are all connected with the Glasgow and South-Western Railway. The whole manufacture of iron in Ayrshire is in the hands of three great companies, namely, William Baird & Company, the Dalmellington Iron Company, and Merry & Cunningham. Hæmatite of good quality is raised in Sorn and Muirkirk, and discoveries of it have been made in Carrick. The coal-fields are of great extent, and limestone exists in large quantities. A valuable whetstone quarry is worked at Bridge of Stair on the Ayr.

The old harbours of the county were at Ayr, Irvine, and Saltcoats. The latter is now neglected, and its place is supplied by the more important harbour of Ardrossan. The works at Ardrossan were carried through by the private enterprise of the last two earls of Eglinton. They were begun in the early part of this century, with the expectation of making Ardrossan an important shipping port for Glasgow, in connection with a canal, which, however, was never carried further than from Glasgow to Johnstone. The works were designed by Telford. The pier was finished in 1811, and the docks were completed by the late earl. The harbour of Troon was likewise the work of an enterprising nobleman. It was formed by the late duke of Portland, who connected it with Kilmarnock by a railway, which was among the earliest in the country. Troon has an extensive shipping business, as the outlet for the great coal-fields of the Kilmarnock district. Acts of parlia-

ment have been obtained, which sanction harbour improvements at Irvine and Girvan, and a large wet-dock is in course of formation at Ayr. The dock at Ayr is important, as Ayr is the natural outlet for the great coal-fields up the river, and for the ironworks at Dalmellington, Lugar, and Muirkirk, as well as the fields which are being developed on the railways, called the Ayrshire lines, between Cumnock and the river Doon.

The Glasgow, Kilmarnock, and Ayr Railway was partially opened in 1840, and soon after completed. A connection was made a few years later from the Ayr line at Kilwinning to Ardrossan, and an extension from Kilmarnock to Cumnock, with a branch to Muirkirk. Extensions followed from Cumnock to Dumfries and Carlisle, and from Ayr to Dalmellington, and to Maybole and Girvan; and the Troon Railway was acquired from the duke of Portland, as a connecting link of what is now the Glasgow and South-Western Railway system. Other important branches have been made, and a trunk line is now in course of formation between Girvan and Stranraer, which will give a connection between Glasgow and Ayrshire and the north of Ireland by the shortest sea passage. Ayrshire is thus well supplied with railwavs.

The antiquities of Ayrshire are not of much note. There are cairns in Galston, Sorn, and other localities; a road, supposed to be a work of the Romans, which extended from Ayr, through Dalrymple and Dalmellington, towards the Solway; camps, attributed to the Norwegians or Danes, on the hills of Knockgeorgan and Dundonald; and the castles of Loch Doon, Turnberry, Dundonald, Portencross, Ardrossan, &c. There are interesting remains of the celebrated abbeys of Kilwinning and Crosraguel; and the ruins of the little church of Alloway, amid the lovely scenery near the birthplace of Burns, have become more famous from their associations than many great works of architectural genius.

The rural population of Ayrshire is decreasing, but the mining population has increased, and the towns are growing. At the last census there were 27,132 inhabited houses, and the population reached 200,745. The county valuation last year amounted to £1,178,183, 5s. 10d., being an increase of more than £50,000 from the previous year. The amount for Kyle was £446,874, 18s. 5d.; for Cunningham, £411,504, 1s. 6d.; for Carrick, £177,168, 10s. 3d.; for the burgh of Ayr, £63,273, 16s. 6d.; for Kilmarnock, £63,203, 19s.; and for Irvine, £16,159, 0s. 2d.

AYR, the capital of the above county, is situated at the mouth of the river of the same name, and about 40 miles S.S.W. from Glasgow. The spot has probably been inhabited from a remote antiquity. Nothing, however, is known of its history till the close of the 13th century, when it was made a royal residence, and soon afterwards a royal burgh, by William the Lion. The charter conferring upon it the latter privilege has been preserved, of which a fac-simile will be found in vol. i. of the *National Manuscripts of Scotland*. During the wars of Scottish independence the possession of Ayr and its castle was, according to tradition, an object of importance to both the contending parties. In Blind Harry's *Life of Wallace* they are frequently mentioned, and the scene is laid there of one of the patriot's greatest exploits; but the authenticity of many of the minstrel-historian's statements is more than doubtful. On better authority, the records of the burgh, it is known that early in the 16th century Ayr was a place of considerable influence and trade. The liberality of William the Lion had bestowed upon the corporation an extensive grant of lands; while in addition to the well-endowed church of St John's, it had two monasteries, each possessed of a fair revenue. When Scotland was overrun by Oliver Cromwell, Ayr was selected as the

site of one of those forts which he built to command the country. This fortification, termed the citadel, enclosed an area of ten or twelve acres, and included within its limits the church of St John's, in which the Scottish Parliament on one occasion met, and confirmed the title of Robert Bruce to the throne. The church was converted into a storehouse, the Protector partly indemnifying the inhabitants for this seizure by liberally contributing towards the erection of a new place of worship, now known as the Old Church. Ayr proper lies on the south bank of the river, and is connected with Newton and Wallace town on the north by two bridges, the Old and the New, the "Twa Brigs" of Burns. Of late years the town has extended greatly on the Ayr side of the stream. Nearly the whole of Cromwell's Fort is now covered with houses, and to the south, in the direction of the racecourse, numerous fine villas have been erected. Ayr possesses several good streets and a number of elegant public and other edifices. The County Buildings, which afford accommodation for the circuit and provincial courts, as well as for the various local authorities, occupy the west side of Wellington Square. Contiguous to these is the jail, a well-regulated establishment, partly used as a penitentiary. The Town's Buildings, near the New Bridge, is a handsome erection, the effect of which is somewhat impaired by the lowness of the site. They contain assembly rooms and a reading-room, and are surmounted by a spire 217 feet high, designed by Hamilton, of Edinburgh, and considered by many the finest in the west of Scotland. All the Edinburgh and Glasgow banks have branches in Ayr, and some of them have built ornamental structures for their accommodation. Besides the old church already mentioned, there is another parish church called the New, and a number of dissenting places of worship, none of them, however, noteworthy on account of their architecture. The Academy, a large building in a convenient position, includes, or has superseded, the Grammar School of the burgh, the existence of which can be traced back as far as the 13th century. A portion of the tower of St John's Church still remains, but, to the regret of the antiquary, has been completely modernised. The "Wallace Tower" is a Gothic structure in High Street, erected on the site of an old building of the same name taken down in 1835. A niche in front is filled by a statue of the Scottish hero by Thom, a self-taught sculptor, who executed in a much more successful manner the statues of Tam o' Shanter and Souter Johnnie, now in the grounds of Burns' Monument. Ayr Hospital is a plain but substantial erection near the Townhead railway station. There are two subscription libraries in the town, and it also supports one weekly and one bi-weekly newspaper. Its religious and charitable societies are numerous. A market is held every Tuesday, and there are five yearly fairs. The Western Meeting takes place in September of every year on Ayr racecourse, a large enclosure in the suburbs, which has been reserved for this purpose for more than a century. Alloway Kirk and Burns' Monument are distant 2½ miles. The principal manufactures of Ayr are leather, carpets, woollen goods, &c.; and fisheries and shipbuilding are also carried on to a small extent. There are several foundries and engineering establishments. Ayr has a general trade of considerable value. Large quantities of timber are imported from Canada and from Norway; coal and iron are the chief exports. The harbour occupies both sides of the river from the New Bridge to the sea, and has been built at a very considerable expense in a most substantial manner. The south pier projects some distance into the sea; on the north side is a large breakwater protecting the entrance, and on the north pier are three lights, two bright and one red from 13 to



35 feet above high water. The depth of water at the bar is about 14 feet at neap and 16 at spring tides. Extensive docks are in the course of formation, which are expected to increase largely the importance of the place as a seaport. Railways converge upon Ayr from the north, east, and south, opening up a connection with all parts of the country. The burgh unites with Irvine, Inveraray, Campbeltown, and Oban in returning a member to Parliament. Previous to 1873, its municipal boundary on the north was the river, but an Act of Parliament was obtained in that year by which this boundary was extended so as to include Newton-on-Ayr and Wallacetown, and made the same as that of the parliamentary burgh. The corporation of Ayr consists of a provost and four bailies, and twelve town councillors. In 1871 the population of the extended burgh was 17,851. Though thus conjoined with Ayr for the parliamentary franchise and municipal government, and forming with it in reality but one town, Newton and Wallacetown were formerly each quite separate. The former is a burgh or barony of very ancient erection. The original charter has been lost; but it is traditionally said to have been granted by King Robert the Bruce in favour of forty-eight of the inhabitants who had distinguished themselves at Bannockburn. Be this as it may, the common property of the burgh is held to be the exclusive property of the freemen, forty-eight in number. The extent of the lots possessed by each varies from six to ten acres, and their value is considerable. Newton has a council, consisting of two bailies, a treasurer, and six councillors, annually elected by the freemen from among their own number; but the powers of the council, though originally extensive, are now very limited. Wallacetown is *quoad civilia* a part of the neighbouring pariah of St Quivox. About two miles east of Newton is the village of Prestwick, the headquarters of one of the most flourishing golf clubs in Scotland.

AYRER, JACOB, one of the earliest dramatists of Germany, was born in 1560, probably at Nuremberg,—at least he resided there when a mere boy. His first occupation was keeping an iron-store, which he did with considerable success. After studying law for some time at Bamberg, where he attained a good position as a lawyer, he returned to Nuremberg, and continued to practise there, acquiring the freedom of the city in 1594, and ultimately becoming an imperial notary. He died 26th March 1605. Ayer's works consist of numerous small poems, and of the series of dramas on which his fame rests. Like other dramas of the time, his productions are, for the most part, spectacular displays, with laboured dialogue, and vary in length from five to twenty-eight acts. The plots are plainly taken from the Latin and Italian tales which supplied material to nearly all the early European dramatists. The chief interest of Ayer's works for English readers arise from their connection with Shakespeare. Ayer adopted several of Shakespeare's plots, as well as his method of representing the characters on the stage after life, "and so produced," says his editor, "according to the new English manner and art, that all can be personally acted and placed so that it shall seem to the spectators to be really happening." In Ayer's time the dramatic spirit in England was strong, and good plays and players abounded. Some of the latter took circuits through Germany, and though performing in their native tongue, excited enthusiasm by their vivacity. Ayer caught this enthusiasm, and adapted several of the English dramas to the German stage. The *Opus Theatricum*, in one folio volume of 1262 pages, was published posthumously in 1618. It contained thirty plays and thirty-six carnival interludes. A second volume to contain forty more, though promised, did not appear. Of the

comedies and tragedies of Ayer, six have been reproduced with an English translation in Cohn's *Shakespeare in Germany*. These contain respectively plots resembling *The Tempest*, *Much Ado about Nothing*, *The Two Gentlemen of Verona*, *Titus Andronicus*, *Romeo and Juliet*, and *Hamlet*. In 1601, a comic prose work by Ayer was published, giving an account of an *Imaginary Suit of the Devil against Jesus Christ for Destroying Hell*. Some of his plays were published prior to 1585, but these are not now to be had, and even the folio of 1618 is extremely rare. Further information about Ayer may be gained from Tieck's *Deutsches Theater*, vol. i.; Wolff's *Encyc. der Deutschen Nationalliteratur*, vol. i.; Cohn's *Shakespeare in Germany*; Dr Bell's *Shakespeare's Puck, and his Folklore*; Dr Latham's *Two Dissertations on "Hamlet:" W. J. Thom's Three Notelets on Shakespeare*.

AYTON, SIR ROBERT (1570-1638), a Scottish lyrical poet, the second son of Andrew Ayton of Kinaldie in Fifeshire, was educated at the University of St Andrews, and seems afterwards to have resided for several years in France, where he gained considerable reputation as a poet and scholar. On the accession of James VI. in 1603, Ayton published a very elegant Latin panegyric, which at once brought him into notice and favour at court. He was knighted by the king, and held various important offices, particularly that of private secretary to the queen. He was of an exceedingly amiable disposition, and was much beloved by his contemporaries; even Ben Jonson, who criticised all other poets so severely, seems to have made an exception in his favour, for he told Drummond that Sir Robert loved him dearly. Ayton's extant works consist of some Latin poems, and of a few pieces in the English dialect, which are distinguished by smoothness of rhythm and delicacy of fancy. His best ode, *Inconstancy Reproved*, beginning, "I do confess thou'rt smooth and fair," may take rank with the finest pieces of Herrick or Suckling, while a few others are but little inferior. His poems have been collected and published by Sir C. Roger (Edin. 1844).

AYTOUN, WILLIAM EDMONSTOUNE, a Scottish poet, humourist, and miscellaneous writer, was born at Edinburgh, 21st June 1813. He was the only son of Roger Aytoun, a writer to the Signet, and the family was of the same stock as Sir Robert Ayton noticed above. From his mother, a woman of marked originality of character and considerable culture, he derived his distinctive qualities, his early tastes in literature, and his political sympathies, his love for ballad poetry, and his admiration for the Stuarts. At the age of eleven he was sent to the Edinburgh Academy, whence he passed in due time to the University, studied the classics under Professors Pillans and Dunbar, and attended the course of Professor John Wilson on Moral Philosophy. In 1833 he spent a few months in London for the purpose of studying the law; but in September of that year he went to study German at Aschaffenburg, where he remained till April 1834. He then resumed his legal pursuits in his father's chambers, was admitted a writer to the Signet in 1835, and five years later was called to the Scottish bar. But, by his own confession, though he "followed the law, he never could overtake it." He disliked his profession, and allowed his literary tastes to predominate. His first publication—a volume entitled *Poland, Homer, and other Poems*, in which he gave expression to his eager interest in the state of Poland—appeared in 1832. While in Germany he made a translation in blank verse of the first part of *Faust*; but, forestalled by other translations, it was never published. In 1836 he made his earliest contributions to *Blackwood's Magazine*, in translations from Uhland; and from 1839 till his death he remained on the staff of *Blackwood*. About 1841 he became acquainted with Mr. Theo-

dore Martin, and in association with him wrote a series of light humorous papers on the tastes and follies of the day, in which were interspersed the verses which afterwards became popular as the *Bon Gualtier Ballads*. The work on which his reputation as a poet chiefly rests is the *Lays of the Scottish Cavaliers*. The first of these appeared in *Blackwood's Magazine* in April 1843, and the whole were published in a collected edition in 1848. They became very popular, and have passed through nineteen editions, the last of which has spirited and beautiful illustrations by Sir J. Noel Paton and W. H. Paton. Meanwhile, he obtained, in 1845, the chair of Rhetoric and Belles Lettres at Edinburgh University, which he filled honourably and successfully till 1864. He devoted himself conscientiously to the duties of the office, and his pupils increased in number from 30 to 150. In 1849 he married the youngest daughter of Professor John Wilson (Christopher North), whose death, in 1859, was the great calamity of his life. His services in support of the Tory party, especially during the Anti-Corn-Law struggle, received official recognition in his appointment (1852) as sheriff of Orkney and Zetland. In 1864 appeared *Firmilian, a Spasmodic Tragedy*, in which he attacked and parodied the writings of Bailey, Sydney Dobell, and Alexander Smith; and two years later he published his *Bothwell, a Poem*. Among his other literary works are a *Collection of the Ballads of Scotland*, a translation of the *Poems and Ballads of Goethe*, executed in co-operation with his friend Theodore Martin, a small volume on the *Life and Times of Richard I.*, written for the *Family Library*, and a novel entitled *Norman Sinclair*, many of the details in which are taken from incidents in his own experience. In 1860 Aytoun was elected honorary president of the Associated Societies of Edinburgh University. The death of his mother took place in November 1861, and his own health was failing. In December 1863 he married Miss Kinnear, and health and happiness for a time revived; but his malady recurred, and he died at Blackhills, near Elgin, 4th August 1865. His remains were interred at Edinburgh. A memoir of Aytoun by Theodore Martin, with an appendix containing some of his prose essays, was published in 1867. (w. l. x. c.)

AZAIS, PIERRE HYACINTHE, a brilliant French writer on philosophy, was born at Sorrèze in 1766, and died at Paris in 1845. He was educated at the college in his native town; and at the age of 17 joined a religious body with the view of afterwards entering the church. He remained only a year in this society, and then accepted an appointment as teacher in the college at Tarbes. The duties of this office proved most uncongenial to him, and he gladly entered the service of the bishop of Oléron, to whom he acted as secretary. With this, too, he quickly became dissatisfied, either on account of the bishop's reiterated desire that he should take orders, or from the many petty annoyances incident to his post. He withdrew to the little village of Villemagne, near Beziers, where he supported himself by performing the duties of organist in the church. He afterwards acted as tutor to the Count de Bosc's sons, with whom he remained till the outbreak of the Revolution. Azais, at first an ardent admirer of that great movement, was struck with dismay at the atrocities that were perpetrated, and published a vehement pamphlet on the subject. He was denounced, and had to seek safety in flight. For eighteen months he found refuge in the hospital of the Sisters of Charity at Tarbes; and it was not till 1806 that he was able to settle in Paris. There, three years later, he published his treatise *Des Compensations dans les Destinées Humaines*, in which he sought to show that happiness and misery were fairly balanced in this world, and that consequently it was the duty of citizens to submit quietly to a fixed government.

This doctrine was not displeasing to Napoleon, who made its author professor at St Cyr. After the removal of that college, he obtained, in 1811, the post of inspector of the public library at Avignon, and from 1812 to 1815 he held a similar office at Nancy. His preference for the Bonaparte dynasty naturally operated in his disfavour at the Restoration; but after suffering considerable privation for some years, he obtained a government pension, which placed him beyond the reach of want. He employed the remaining years of his life in oral and published expositions of his system of philosophy.

According to Azais, the whole of existence, the universe, whose cause is God, may be regarded as the product of two factors, Matter and Force. Matter in its primitive state consists of homogeneous elements or atoms. All force is in its nature expansive, and is, therefore, subject to one supreme law; that of equilibrium, or equivalence of action and reaction; for evidently expansive force emanating from each body is repressive force acting on all other bodies. The whole of the phenomena of the universe are successive stages in the development caused by the action of this one force under its one law on the primitive atoms; and in tracing this development we must group facts into three distinct orders,—first, the physical; second, the physiological; third, the intellectual, moral, and political. In the sphere of physical phenomena, distinct development can be traced from the simplest mechanical motion up through the more complex forces of light, heat, and electricity to the power of magnetic attraction, by means of which the second great order of facts is produced out of the first. For magnetic force acting on elastic bodies, which as reactive have potential life, creates the primitive living globule, which is shaped like a tube open at both ends. From this first vital element a gradual ascent can be traced, culminating in man, who is differentiated from the other animals by the possession of intellect, or consciousness of the ideas with which external things impress him. These ideas, however, are in themselves corporeal; what is immaterial in man, or his soul, is the expansive force inherent in him. Moral and political phenomena are the results of two primitive instincts, progress and self-conservation, corresponding to the two forces, expansion and retraction. From the reciprocal relations of these instincts may be deduced the necessary conditions of social and political life. The ultimate goal of humanity is the perfect fulfilment of the law of equilibrium, the establishment of universal harmony. When that is accomplished, the destiny of man has been achieved, and he will vanish from this earth. Such a consummation may be looked for in about 7000 years. During an additional period of 5000 years the great cosmical forces will be gradually tending towards the establishment of complete equilibrium; and, when this is attained, the present system of things is at an end.

The chief works of Azais, besides the *Compensations*, are—*Système Universel*, 8 vols. 1812; *Du Sort de l'Homme*, 3 vols. 1820; *Cours de Philosophie*, 8 vols. 1834; *Explication Universelle*, 3 vols. 1828-9; *Jouissance, Maturité, Religion, Philosophie*, 1837; *De la Phronologie, du Magnétisme, et de la Folie*, 1845.

AZARA, DON FELIX DE, a Spanish naturalist, was born 18th May 1746, and died in 1811. He studied first at the university of Huesca, and afterwards at the military academy of Barcelona. In 1764 he entered the army as a cadet, and in 1767 obtained an ensigncy in the engineer corps. In 1781 he was appointed, with the rank of lieutenant-colonel of engineers and captain in the navy, on a commission to lay down the line of demarcation between the Spanish and the Portuguese territories in South America. There he spent many years, observing and collecting specimens of the various interesting objects of

natural history that abound in those wide and little-known regions. In 1801 he obtained leave to return to Spain, and after a short residence at Paris, was appointed a member of the *Junta de fortificaciones y defensa de Ambos Indias*, a public board, in which chiefly was centred the home government of the Spanish colonies. His principal work is his *Travels in South America from 1781 to 1801*; published in French from the author's MS., by C. A. Walckensær, with atlas and plates, 4 vols. 8vo, Paris, 1809. It contains a valuable account of the discovery, conquest, and civil and natural history of Paraguay and Rio de la Plata; and embodies his former contributions to the zoology of these countries, which had appeared in a French translation at Paris in 1801. The work is enriched with the notes of Walckensær and Cuvier, and a notice of the author by the former. An English translation of part of Azara's work on the *Natural History of Paraguay* appeared at Edinburgh in 1838.

AZARA, DON JOSE NICHOLAS D', the elder brother of the naturalist, born in 1731, was appointed in 1765 Spanish agent and procurator-general, and in 1785, ambassador at Rome. During his long residence there he distinguished himself as a collector of Italian antiquities and as a patron of art. He was also an able and active diplomatist, took a leading share in the difficult and hazardous task of the expulsion of the Jesuits from Spain, and was instrumental in securing the election of Pius VI. He withdrew to Florence when the French took possession of Rome in 1798. He was afterwards Spanish ambassador at Paris; was three times deprived of, and restored to his office; and was finally preparing to return to his antiquarian studies in Italy when he was seized with a fatal illness, and died at Paris in January 1804.

AZEGLIO, MASSIMO TAPARELLI, MARQUIS D', an eminent Italian author and statesman, was born in October 1798, at Turin. He was descended from an ancient and noble family of Piedmont, and was the son of a military officer, who, when the subject of this notice was in his fifteenth year, was appointed ambassador to Rome. The boy went with him, and, being thus introduced to the magnificent works of art for which the Eternal City is famous, contracted a love for painting, as well as for music. He desired to become a painter, and, although his studies were for a time interrupted by his receiving a commission in a Piedmontese cavalry regiment, and by a subsequent illness, brought on by the severity of his scientific investigations and resulting in his quitting the service, he eventually returned to Rome, and, with some difficulty, obtained his father's permission to devote himself to art. He remained at the Papal capital eight years, and acquired great skill and some fame as a landscape-painter. At the close of that period events directed his mind into other channels. His father died in 1830, and the younger Azeglio then removed to Milan, where he became acquainted with Alessandro Manzoni, the poet and novelist, whose daughter he married. In this way his thoughts were turned towards literature and politics. At that time, Italy was profoundly agitated by the views of the national and liberal party. The country was divided into several distinct states, of which the greater number, even of those that were nominally independent, were under the influence of Austria. Lombardy and Venetia formed parts of the Austrian dominions. The petty monarchies of the north were little better than vassals to the house of Hapsburg; the Papacy, in the centre, was opposed to all national aspirations; and the kingdom of the Two Sicilies, in the south, was a despotism, which for cruelty and mental darkness could not have been exceeded in Asia itself. The French revolution of July 1830 gave additional force to the movements of the Italian liberal

party, and the young men of the day threw themselves with fervour into the crusade against old abuses and foreign domination. Mazzini was just beginning his career as an agitator, and the whole air was surcharged with revolutionary enthusiasm. This was especially the case in the north of Italy, where Massimo d'Azeglio was now settled. Art was abandoned by him for literature, and literature was practised with a view to stimulating the sense of national independence and unity. In 1833, M. d'Azeglio published a novel called *Ettore Fieramosca*, which was followed in 1841 by another, entitled *Niccolo di Lapi*. Both had a political tendency, and, between the two dates at which they appeared, M. d'Azeglio visited various parts of Italy, diffusing those liberal principles which he saw were the only hope of the future. His views, however, were very different from those of the republican party. He was a constitutional monarchist, and strongly opposed to the insurrections and secret conspiracies which Mazzini and others so frequently fostered at that time, and which always resulted in failure and renewed oppression. His treatise *Degli Ultimi Casi di Romagna* (Of the Last Events in the Romagna), published in 1846, before the death of Pope Gregory XVI, was at once a satire on the Papal Government, a denunciation of the republican attempts at insurrection, and an exhortation to the Italian princes to adopt a national policy. M. d'Azeglio returned to Rome in 1846, after the death of Pope Gregory, in June, and, it is thought, had considerable influence in persuading the new Pope (Pius IX.) to conduct his government in accordance with liberal principles. He supported measures relating to the freedom of the press, the reform of the Papacy, and the emancipation of the Jews. In 1848 he accompanied the Papal army of observation sent from Rome to watch the insurgent forces in Lombardy and Venetia, which had temporarily discomfited the Austrians, and were being supported by Charles Albert, king of Sardinia. General Durando, who had the command of the Papal army, actively assisted the rebels, in defiance, it is said, of his instructions; and Azeglio was severely wounded in the leg at the battle of Vicenza, where he commanded a legion. In the same year (1848), he published a work on the *Austrian Assassinations in Lombardy*; and on the opening of the first Sardinian parliament he was chosen a member of the chamber of deputies. After the crushing defeat of the Sardinians at Novara, March 23, 1849,—a defeat which brought the second of the two brief wars with Austria to a disastrous close,—D'Azeglio was made president of the cabinet by Victor Emmanuel, in whose favour his father, Charles Albert, had just resigned. In this position the marquis used his high powers with great advantage to the progress and consolidation of the Sardinian kingdom. His occupation of the office lasted from the 11th of May 1849 to the 20th of October 1852, when he was replaced by Count Cavour. At the termination of the war of 1859, when a large portion of the States of the Church shook off the dominion of the Pope, and declared for annexation to the kingdom of Northern Italy, Azeglio was appointed general and commissioner-extraordinary, purely military, for the Roman States—a temporary office, which he administered in a conciliatory and sagacious spirit. He died on the 11th of January 1866, leaving a reputation for probity and wisdom, which his countrymen will not forget to cherish. His writings, chiefly of a polemical character, were numerous. In addition to those already mentioned, the most noteworthy was a work on *The Court of Rome and the Gospels*, of which an English translation, with a preface by Dr Layard, appeared in 1859. A volume of personal recollections was issued, in 1867, after M. d'Azeglio's death.

AZERBLJAN (so called, according to Sir William Ouseley, from a fire-temple; *azer*, fire, and *bajjan*, a keeper), a pro-

vince of Persia, corresponding to the ancient Atropatena. It is separated from a division of the Russian Empire on the N. by the River Araxes, and from Irak on the S. by the Kizil-Uzen, or Golden Stream, while it has the Caspian Sea and Ghilan on the E., and Asiatic Turkey on the W. Its area is estimated at 25,280 square miles. The country is superior in fertility to the southern provinces of Persia. It differs entirely from the provinces of Fars and Irak, as it consists of a regular succession of undulating eminences, partially cultivated, and opening into extensive plains such as Anjan, Tabreez, and Urumiyah or Van. Near the centre of the province the mountains of Sahend or Serhund rise in an accumulated mass to the height of 9000 feet above the sea. The highest point, Mount Sevellan, towards its eastern frontier, attains a height of about 12,000 feet according to some authorities, but according to Khanikoff, it is 15,400; and the Talish Mountains, which run from N. to S. parallel to, and at no great distance from, the Caspian, have an altitude of 7000 feet. Except the boundary rivers already mentioned, there are none of any great extent; but these both receive a number of tributaries from the province, and several streams of considerable volume, such as the Jughutu, the Agi, and the Shar, belong to the basin of the Lake Urumiyah. This lake is about 300 miles in circumference, and 4200 feet above the sea. Its waters are more intensely salt than the sea, and it is "supposed to contain no living creature except a kind of polype;" but it is the resort of great flocks of the flamingo. The country to the N. and W., namely, the districts of Urumiyah and Selmart, is the most picturesque and prosperous part of Azerbaijan; yet even here the traveller from the more civilised regions of Europe laments the want of enterprise among the inhabitants. Azerbaijan is on the whole, however, reckoned one of the most productive provinces of Persia, and the villages have a more pleasing appearance than those of Irak. The orchards and gardens, in which they are for the most part embosomed, yield delicious fruits of almost every description, which are dried in large quantities. Provisions are cheap and abundant, and wine is made in considerable quantities. There is throughout the district a lack of forests and of timber trees. Lead, copper, saltpetre, sulphur, and coal are found within the confines of Azerbaijan; also a kind of beautiful transparent marble or jasper, which takes the highest polish, and is used in the buildings of Tabreez, Shiraz, and Ispahan, under the name of Tabreez or Belghami marble. There are exports of silk and cotton, textile fabrics, leather, hides and lambskins, dry-fruits, sugar, drugs, tobaccó, and wax, &c., the total value in 1870, a year of great trade depression, being £422,632. In the same year the imports amounted to £1,094,717. The chief towns are Tabreez, Urumiyah (the supposed birthplace of Zoroaster), Ardebil, Khoe, Maragha, Dilman, Abbasabad, Mehrand, Siral, and Souj-Bolak. The climate is healthful—in summer and autumn hot, but cold in winter. The cold is severely felt by the lower orders, owing to the want of fuel, for which there is no substitute except dried cow-dung, mixed with straw. The spring is temperate and delightful in the plains, but on the mountains snow lies eight months in the year; and hail-storms are so violent as frequently to destroy the cattle in the fields. The best soils yield from fifty to sixty fold when abundantly irrigated; and supplies of water for this purpose are drawn from the many small rivers by which the province is intersected. Oxen are generally used to draw the plough. The population is of a very varied character, comprising Kurds, Armenians, Syrians, Tatars, Persians proper, and other tribes or nationalities, and is roughly estimated at 2,000,000. The Persian army is largely composed of natives of Azerbaijan, who make ex-

cellent soldiers; they are subject to compulsory enlistment. The province is under the government of the heir-apparent to the Persian throne. (Kinneir's *Geographical Memoir of the Persian Empire*, 1813; Fraser's *Travels and Adventures in the Persian Provinces on the Caspian Sea*; Rawlinson's "Tabriz to Takhti Suleiman," in *Jour. of Roy. Geog. Soc.*, 1840; Chesney's *Euphrates and Tigris Expedition*, 1850; Abbott's "Memorandum" in *Proc. of Roy. Geog. Soc.*, 1864.)

AZIMGARH, a district and city in the Benares division of British India, and under the jurisdiction of the Lieutenant-Governor of the North-Western Provinces, lies between 25° 38' 3" and 26° 24' 45" N. lat., and 82° 44' 15" and 84° 10' 45" E. long. It is bounded on the N. by the river Ghagrá, separating it from Gorakhpur district; on the E. by Gházipur district and the river Ganges; on the S. by the districts of Jaunpur and Gházipur; and on the W. by Jaunpur and the Oudh district of Faizábad. Its area in 1872 was returned at 2494 square miles, of which 1268 square miles are under cultivation, 344 square miles are cultivable waste, and the remaining 882 square miles are barren and uncultivable. The population of the district in 1865 was 1,385,872 souls, of whom 1,184,689 were Hindus, and 201,183 Mahometans. The pressure of the population on the soil averaged 555 per square mile. The census of 1872 discloses a population of 1,531,410, of whom 1,333,805 were Hindus, 197,581 Mahometans, and 24 Christians and others; the pressure of the population on the land being 614 per square mile. The portion of the district lying along the banks of the Ghagrá is a low-lying tract, varying considerably in width; south of this, however, the ground takes a slight rise. The slope of the land is from north-west to south-east, but the general drainage is very inadequate. Roughly speaking, the district consists of a series of parallel ridges, whose summits are depressed into beds or hollows, along which the rivers flow; while between the ridges are low-lying rice lands, interspersed with numerous natural reservoirs. The principal streams are the Tons, Sarjú, Khúrd, Kunwar, Majhor, Mangá, Udantí or Aurá, and the Bhanásí. The chief lines of road traffic are the following—(1.) From Gorakhpur to Gházipur, running north and south; (2.) from Gorakhpur to Azimgarh town, in a north-easterly and south-westerly direction, and continued thence to Jaunpur cantonment; (3.) from Gházipur to Azimgarh, and thence on to Faizábad in Oudh; (4.) from Gházipur to Lucknow. The soil is fertile and very highly cultivated, bearing magnificent crops of rice, sugar-cane, and indigo. The principal industries of the district are cotton and silk manufactures, the total value of which in 1872 amounted to £109,081. The settlement of the land revenue in 702 estates or mahals is fixed and permanent; in the remaining 3284 estates a settlement was made by Mr Thomason in 1836 for thirty years, and is now (1873) undergoing revision. The total revenue of the district from all sources amounted in 1870-71 to £187,464; the expenditure in the same year being £172,550. Six towns are returned by the census of 1872 as containing a population of upwards of 5000 inhabitants—viz., Azimgarh (the capital of the district), population 15,893; Mán-Náth Bhanjan, 13,765; Mubárákpur, 12,068; Sikandarpur, 5239; Dubarí, 5014; and Pur, 5213. The municipalities are as follows:—Azimgarh city: the municipal income, which is derived from octroi, amounted in 1872 to £1233, 2s., the average incidence of taxation being 1s. 6½d. per head of the population. Mán-Náth Bhanjan, municipal income £125, 8s.; Mubárákpur, £112, 16s.; and Sikandarpur, £48. The cost of the municipal police of these three towns is levied by means of a direct cess on house occupiers. The total number of schools in Azimgarh district in 1871-72 was 286, attended

by 4271 Hindu and 3813 Mahometan pupils. The force necessary for the protection of person and property in 1871-72 consisted of 673 regular police, equal to 1 man to every 3·70 square miles of area, or 1 to every 2275 inhabitants; besides a village watch or rural police force consisting of 2538 men, equal to 1 watchman to every 0·98 square miles, or 1 to every 603 inhabitants.

**AZINGARE CITY**, the principal place in the district of the same name, is situated on the river Tons, in 26° 0' N. lat., and 83° 14' E. long. The city is said to have been founded about 1620 by a powerful landholder named Asim Khán, who owned large estates in this part of the country. For municipal income and population, see above.

**AZO**, a distinguished professor of civil law in the university of Bologna, and a native of that city. He was the pupil of Joannes Bassianus, who taught at Bologna towards the end of the 12th century, and who was the author of the famous *Arbor Actionum*. Azo, whose name is sometimes written Aszo and Aszolennus, and who is sometimes described as Azo Soldanus, from the surname of his father, occupied a very important position amongst the gloss-writers, and his *Readings (Lectura) on the Code*, which were collected by his pupil, Alexander de Sancto Egidio, are considered by Savigny, a most competent judge, to be the most valuable of the works of that school which have come down to us.

**AZOFF**, or **ASOV** (in Turkish, *Asak*), a town on the left bank of the southern arm of the Don, about 20 miles from its mouth. Its identification with the ancient Tanais and the mediæval Tana seems erroneous; but it was long a place of great importance both as a military and commercial position. Peter the Great obtained possession of it after a protracted siege in 1696, and did a great deal for the security and prosperity of the town. At the peace of 1711, however, he had to restore it to the Turks; and it was not till 1774 that it was finally united to the Russian empire. Since then it has greatly declined, owing to the silting up of its harbour and the competition of the city of Taganrog. Its population, principally engaged in the fisheries, numbers, according to Russian statistics, 16,791.

**AZOFF, THE SEA OF**, an inland sea of Southern Europe, communicating with the Black Sea by the Strait of Yenikale, the ancient *Bosphorus Cimmerius*. To the Romans it was known as the *Palus Mæotis*, from the name of the neighbouring people, who called it in their native language *Temarenda*, or Mother of Waters. Possibly to account for the outward current into the Black Sea, it was long supposed to possess direct communication with the Northern Ocean, and, when it was discovered that there was no visible channel, recourse was had to a "secret sluice," there being, it was thought, but a comparatively narrow isthmus to be crossed. In some prehistoric time, according to Pallas and Murchison, a connection with the Caspian Sea seems to have existed; but no great change has taken place in regard to the character or relations of the Sea of Azoff since our earliest records. It lies between 45° 20' and 47° 18' N. lat., and between 36° and 39° E. long., its length from S.W. to N.E. being about 235 miles, and its greatest breadth 110. It is for the most part comparatively shallow; the deepest portion forming as it were a prolongation of the bed of the Don, its largest and, indeed, its only very important tributary. Near the mouth of that river the depth varies from 3 to 10 feet, and the greatest depth does not exceed 44 feet. Fierce and continuous winds from the E. prevail during July and August, and in the later part of the year those from the N.E. and S.E. are not unusual. A great variety of currents are thus produced, and the relative depths of the different parts of the sea are greatly modified. From December to March the whole surface is generally frozen.

The water is for the most part comparatively fresh, but differs considerably in this respect according to locality and current. Fish are so abundant that the Turks use the name *Baltik-Denis*, or Fish-Sea. To the W., separated from the main basin by the long, narrow spit of Arabat, lies the remarkable series of lagunes and marahe known as the Sivaah, or Putrid Sea. Here the water is intensely salt, and at the same time swarms with life. The Sea of Azoff is of great importance to Russian commerce, and a number of flourishing cities have grown up along its shores. Of these the most important are Taganrog, Bardianak, Mariupol, and Yenikale. Unfortunately, there is a lack of safe and commodious harbours and roads.

**AZORES, THE, OR WESTERN ISLANDS**, are situated in the Atlantic Ocean, and extend in an oblique line from N.W. to S.E., between 36° 55' and 39° 55' N. lat., and between 25° and 31° 16' W. long. They are generally considered as pertaining to Europe, though separated by a distance of 800 miles from the coast of Portugal. They are divided into three distinct groups: the south-eastern consisting of São-Miguel, or St Michael's, and Sta Maria; the central and largest, of Fayal, Pico, São Jorge, Terceira, and Graciosa; and the north-western, of Flores and Corvo.

It does not appear that the ancient Greeks and Romans had any knowledge of the Azores, but from the number of Carthaginian coins discovered at Corvo it has been supposed that the islands must have been visited by that adventurous people. The Arabian geographers, Edrisi in the 12th century, and Ibn-al-Wardi in the 14th, describe, after the Canaries, nine other islands in the Western Ocean, which are in all probability the Azores. This identification is supported by various considerations. The number of islands is the same; the climate under which they are placed by the Arabians makes them north of the Canaries; and special mention is made of the hawks or buzzards, which were sufficiently numerous at a later period to give rise to the present name (Port. *Apor*, a hawk.) The Arabian writers represent them as having been populous, and as having contained cities of some magnitude; but they state that the inhabitants had been greatly reduced by intestine warfare. The Azores are first found distinctly marked in a map of 1351, the southern group being named the Goat Islands (*Gabreræ*); the middle group, the Wind or Dove Islands (*De Ventura sive de Columbiæ*); and the western, the Brazil Island (*De Bras*)—the word Brazil at that time being employed for any red dye-stuff. In a Catalan map of the year 1375 the island of Corvo is found as *Corvi Marini*, and Flores as *Li Conigi*; while São Jorge is already designated San Zorze. It has been conjectured that the discoverers were Genoese, but of this there is not sufficient evidence. It is plain, however, that the so-called Flemish discovery by Van der Berg is only worthy of the name in a very secondary sense. According to the usual account, he was driven on the islands in 1432, and the news excited considerable interest at the court of Lisbon. The navigator, Gonzalo Velho Cabral—not to be confounded with his greater namesake, Pedro Alvarez Cabral—was sent to prosecute the discovery. Another version relates that Don Henry of Portugal had in his possession a map in which the islands were laid down, and that he sent out Cabral through confidence in its accuracy. The map had been presented to him by his brother, Don Pedro, who had travelled as far as Babylon. Be this as it may, Cabral reached the island, which he named Santa Maria, in 1432, and in 1444 took possession of St Michael's. The other islands were all discovered by 1457. Colonisation had meanwhile been going on prosperously; and in 1466 the Azores were presented by Alphonso V. to his aunt, Isabella, the duchess of Burgundy. An influx of Flemish settlers followed, and the islands became known for a time as the

Flemish Islands. From 1580 to 1640 they were subject to Spain like the rest of the Portuguese kingdom, of which they now form a province. At that time the Azores were the grand rendezvous for the fleets on their voyage home from the Indies; and hence they became a theatre of that maritime warfare which was carried on by the English

under Queen Elizabeth against the Peninsular powers. The connection with England has long since been of a more peaceful description; no other country affording such a ready market for Azorean productions.

The islands are now divided into three administrative districts, which take their names from the chief towns of

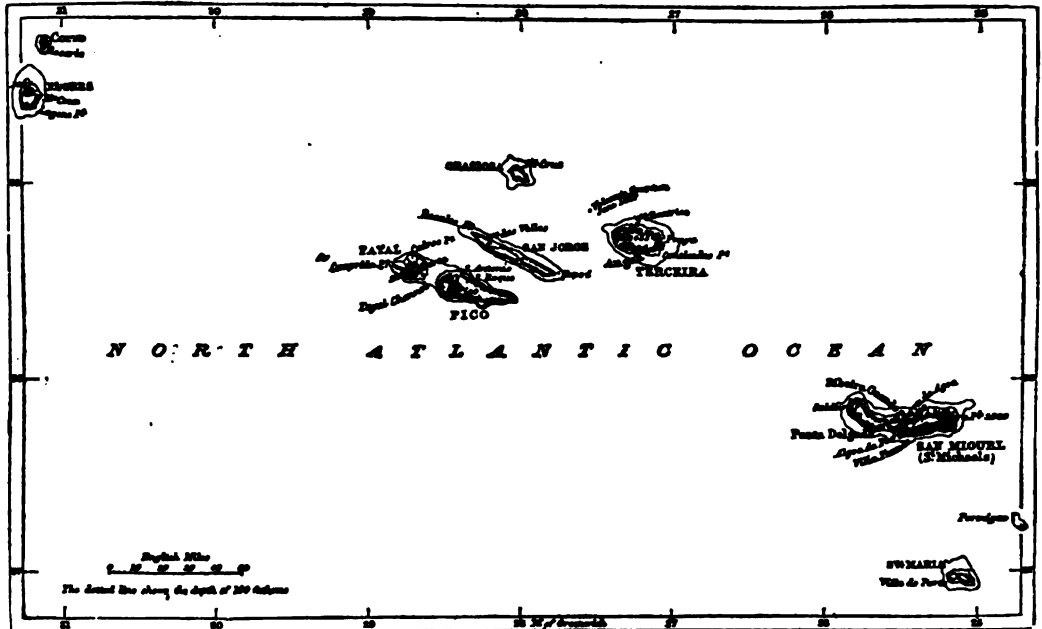

Map of the Azores or Western Islands.

Angra in Terceira, Horta in Fayal, and Ponta-Delgada in St Michael's—the first of the three being also the capital of the islands. The most of the inhabitants are of Portuguese origin, but there is a mixture not only of Flemish but Moorish blood. Negroes, Mulattoes, English, Scotch, and Irish immigrants are present in considerable numbers, especially in San Miguel and Fayal. Education is in a very backward state, the great proportion of the lower classes being unable to read or write. Progress, however, is being made in this as well as other respects.

Under the active administration of Pombal, considerable efforts were made for the improvement of the Azores, but the stupid and bigoted Government which followed rather tended to destroy these benefits, and to create a retrograde course. Towards the beginning of the present century, the possession of the islands was contested by the claimants for the crown of Portugal. The adherents of the constitution, who supported against Miguel the rights of Maria da Gloria, obtained possession of Terceira in 1829, where they succeeded in maintaining themselves, and after various struggles, Queen Maria's authority was established over all the islands. She resided at Angra from 1830 to 1833.

The aspect of all the islands is very similar in general characteristics, presenting an elevated and undulating outline, with little or no table-land, and rising into peaks, of which the lowest (that of Sta Maria) is 1889 feet, and the highest (that of Pico) 7613 feet above the level of the sea. Their lines of sea-coast are, with few exceptions, high and precipitous, with bases of accumulated masses of fallen rock, in which open bays, or scarcely more enclosed inlets, form the harbours of the trading towns. The volcanic character of the whole archipelago is very obvious, and has been abundantly confirmed by the numerous earth-

quakes and eruptions which have taken place since its discovery. Hitherto the western group of Flores and Corvo has been quite exempt, Graciosa has been equally undisturbed, and Fayal has only suffered from one eruption, in 1672. The centre of activity has for the most part been St Michael's, while the neighbouring island of Santa Maria has altogether escaped. In 1444-45 there was a great eruption at St Michael's, of which, however, the accounts that have been preserved exaggerate the importance. In 1522 the town of Villa Franca, at that time the capital of the island, was buried, with all its 6000 inhabitants, during a violent convulsion. In 1572 an eruption took place in the island of Pico; in 1580 St George was the scene of numerous outbursts; and in 1614 a little town in Terceira was destroyed. In 1630, 1652, 1656, 1755, 1852, &c., St Michael has been visited with successive eruptions and earthquakes, several of them of great violence. On various occasions, as in 1638, 1720, 1811, and 1867, subterranean eruptions have taken place, which have sometimes been accompanied by the appearance of temporary islands. Of these the most remarkable was thrown up in June 1811, about half a league from the western extremity of St Michael's. It was called Sabrina by the commander of the British man-of-war of that name, who witnessed the phenomenon. Details will be found in a valuable chapter of Hartung's *Des Azores*, p. 99, and in the 23d vol. of the *Philosophical Transactions*.

The climate is particularly temperate and equable, the extremes of sensible heat and cold being, however, increased by the humidity of the atmosphere. This is so great that paper-hangings will not adhere to the walls, and the veneering of furniture strips off. The range of the thermometer is from 45° Fahr., the lowest known extreme, or 48°, the

ordinary lowest extreme of January, to 82°, the ordinary, or 86°, the highest known extreme of July, near the level of the sea. Between these two points (both taken in the shade) there is from month to month a pretty regular gradation of increase or decrease, amounting to somewhat less than four degrees (*Geographical Journal*, vol. xv.) In winter the prevailing winds are from the north-west, west, and south; while in summer the most frequent are the north, north-east, and east. The weather is often extremely stormy, and the winds from the west and south-west render the navigation of the coasts very dangerous.

The general character of the flora is decidedly European, no fewer than 400 out of the 478 species generally considered as indigenous belonging likewise to that continent, while only four are found in America, and forty are peculiar to the archipelago. Vegetation in most of the islands is remarkably rich, especially in grasses, mosses, and ferns, heath, juniper, and a variety of shrubs. Of tall-growing trees there was, till the present century, an almost total lack; but through the exertions of José de Canto and others the Bordeaux pine, the European poplar, the African palm-tree, the Australian eucalyptus, the chestnut, the tulip-tree, the elm, the oak, and many others, have been successfully introduced into one or more of the islands. The orange, the apricot, the banana, the lemon, the citron, the Japanese medlar, and the pomegranate, are the common fruits, and various other varieties are more or less cultivated. At one time much attention was given to the growing of the sugarcane, but it has now for the most part been abandoned. The culture of woad introduced in the 16th century also belongs to the past. A kind of fern (*Dicksonia calcicola*), called by the natives *cabellinho*, and common throughout the archipelago, furnishes a silky material for the stuffing of mattresses, which forms an article of export to Brazil and Portugal.

The mammalia of the Azores are limited to the rabbit, weasel, ferret, rat (brown and black), mouse, and bat, in addition to domestic animals. Among the fish caught off the coast may be mentioned the mullet, the tunny, the bonito. The numbers of birds are so remarkable that in St Michael's, where a reward is given for the destruction of the blackbird, the bullfinch, the redbreast, the chaffinch, and the canary, the sum paid annually represents a death-list of 420,000. The game includes the woodcock, red partridge (introduced in the 16th century), quail, and snipe.

St Michael's, the largest and most populous of the islands, has an area of 224 square miles, and 105,404 inhabitants. The east end rises from a bluff cliff, from 1200 to 1400 feet high, to a lofty inland peak, whence a central range, varying in height from 2000 to 2500 feet, runs to the westward, terminating in the Serra da Agoa de Paó, 3060 feet above the sea. The sea-coast gradually declines in approaching the last point, where it is not more than about 100 feet high. The middle part of the island is lower, and more undulating; its western extremity being marked by the conspicuous Serra Gorda, 1574 feet above the sea; its shores on both sides are low, broken, and rocky. The aspect of the western portion of the island is that of a vast truncated cone, irregularly cut off at an elevation of about 800 feet, and falling on the N., S., and W. sides to a perpendicular coast of between 300 and 800 feet high. In the higher parts an undergrowth of shrubs gives the mountains a rich and wooded appearance. Like all volcanic countries, the face of the island is uneven and irregular, being deeply excavated by numerous ravines, and roughened by streams of semi-vitrified and scoriaceous lava, that resist all atmospheric influences and repel vegetation. Heavy rains falling on the mountains afford a constant supply of water to four lakes at the bottom of extinct craters, and a number of minor reservoirs, and through them to small streams

running rapidly down on all sides into the sea (*Geographical Journal*, vol. xv.)

Hot springs abound in many parts of the island, and from almost every crevice vapour is seen issuing. But the most remarkable phenomena are the Caldeiras or boiling fountains, which rise chiefly from a valley called the Furnas, near the western extremity of the island. The water ascends in columns to the height of about 12 feet, after which it dissolves in clouds of vapour. The ground in the immediate vicinity is entirely covered with native sulphur, like hoar frost. At a small distance is the Muddy Crater, the vertex of which, 45 feet in diameter, is on a level with the plain. Its contents are in a state of continual and violent ebullition, accompanied with a sound resembling that of a tempestuous ocean. Yet they never rise above its level, unless occasionally to throw to a small distance a spray of the consistence of melted lead. The Furnas abounds also in hot springs, some of them of a very high temperature. There is almost always, however, a cold spring near to the hot one. These springs have for a considerable period been greatly resorted to in cases of palsy, rheumatism, scrofula, and similar maladies, and bath-rooms and various conveniences for visitors have been erected.

The plains are fertile, producing wheat, barley, and Indian corn; whilst vines and oranges grow luxuriantly on the sides of the mountains. The plants are made to spring even from the interstices of the volcanic rocks, which are sometimes blasted to receive them. Raised in this manner, these fruits are said to be of superior quality; but the expense of such a mode of cultivation necessarily restricts it. The western part of the island yields hemp, which might be raised to a considerable extent. The exports consist of wine, fruit, and provisions, the most important trade being in oranges. Foreign intercourse was at one time confined rigorously to Lisbon; but the inhabitants now trade directly with England, America, and other countries. The exports during 1872 at the port of St Michael's were of the value of £85,279, and the imports amounted to £91,943.

The principal town in the island is Ponta-Delgada, which contains 15,520 inhabitants. It is built with tolerable regularity, the streets being straight and broad. The religious edifices are numerous and elegant. The harbour receives only small vessels; those of larger size must anchor in an open roadstead, which cannot be occupied during the prevalence of southerly gales. A breakwater and harbour of refuge have been in process of construction for a number of years; and a lighthouse is being built at the north-east end of the island. The other towns are Villa Franca, Ribeira Grande, Alagoa, Agoa de Paó, &c.

St Mary is a small island immediately adjacent to St Michael's, through the medium of which its trade is conducted, as it has no good harbours of its own. It has an area of 36 square miles, and produces wheat in abundance, of which a considerable quantity is exported. Various volcanic rocks are the predominant formations, but beds of limestone also occur, giving rise to numerous stalactite grottoes all over the island. Population from 7000 to 8000.

Terceira (so called as being the third in order of discovery) is smaller than St Michael's, but being placed in a more central position with respect to the other islands, has been chosen as the seat of government. The port of Angra, protected by Mt. Brazil, is also superior to any of those in St Michael's. This island does not exhibit nearly the same extensive traces of volcanic action; and the summits of its mountains are generally level. It abounds in grain and cattle; but the wines are inferior, and fruits are raised merely for internal consumption. The number of inhabitants is estimated at 50,000.

Fayal (so called from the extreme abundance of the *faya*, an indigenous shrub) is the most frequented of all the Azores, after St Michael's, as it has one of the best harbours in the islands, and lies directly in the track of vessels that are crossing the Atlantic in any direction. Its principal town is Villa de Horta, with a population of 7636. The town is defended by two castles and a wall, both in decay, and serving rather for show than strength. The city contains two convents for monks and three for nuns, with eight churches. The bay is two miles in length and three-quarters of a mile in breadth, and the depth of water from 6 to 20 fathoms. Though a good roadstead, it is not altogether free from danger in S.S.W. and S.E. winds. The women of this island manufacture fine lace from the agave thread, and till recently produced large quantities of open-work stockings. They also execute carvings in snow-white fig-tree pith, and carry on the finer kinds of basket-making. A small valley, called Flemengos, still perpetuates the name of the Flemish settlers, who have left their mark on the physical appearance of the inhabitants. Population, 26,264.

A considerable quantity of wine used to be exported from Fayal under the name of Fayal wine, which was really the produce of Pico, one of the most remarkable of the Azores. This island is composed of an immense conical mountain, rising to the height of 7613 feet, and bearing every trace of volcanic formation. The soil consists entirely of pulverised lava. All the lower parts of the mountain used to be in the highest state of cultivation, and covered with vine and orange plantations. But in 1852 the vines were attacked by the *Oidium* fungus and completely destroyed, while the orange-trees suffered almost as much from the *Coccus Hesperidum*. The people were consequently reduced to want, and forced to emigrate in great numbers. The planting of fig-trees and apricots alleviated the evil, and after a time many of the emigrants returned. Pico also produces a valuable species of wood resembling, and equal in quality to, mahogany. Population, 24,000.

Graciosa and St George are two small islands, situated between Fayal and Terceira. Graciosa, as its name imports, is chiefly noted for the extreme beauty of its aspect and scenery. The chief town is Sta Cruz, and the total population 8000. The only manufacture is the burning of bricks. The chief town of St George is Velas, and the population 18,000.

The two small islands of Corvo and Flores seem but imperfectly to belong to the group. They lie also out of the usual track of navigators; but to those who, missing their course, are led thither, Flores affords good shelter in its numerous bays. Its poultry is excellent; and the cattle are numerous, but small. It derives its name from the abundance of the flowers that find shelter in its deep ravines. Population of Corvo, 1000, and of Flores, 10,508.

See Hartmann's *Edrisi*; *Voyages des Hollandais*, tome i.; *Astley's Collection*, vol. 1.; Masson's "Account of St Miguel" in *Phil. Trans.*, 1778; Cook's *Second Voyage*; Adanson's *Voyage to Senegal*; *History of the Azores*, London, 1818, and the review of this work in the *Quarterly for 1814*; *Bois's Azores*; *London Geographical Journal*; *A Winter in the Azores*, by J. and H. Bullar, 1841; Hartung's *Die Azoren in Ausseren Beschreibung u. Geognost. Natur*, Leipzig, 1860; Morelet's *Iles Azores*, 1860; Drouet's *Éléments de la Faune Açorienne*, 1861; Drouet's *Mollusques Marins des Iles Açores*, 1858; Drouet's *Lettres Açoriennes*, 1862; Ramos (Dr A. G.), *Notícia do Archipelago das Açores*, &c., 1871; Godman's *Nat. Hist. of the Azores*, 1870; "Voyages aux Açores," by Fouqué in the *Revue des Deux Mondes*, 1873; "Allgemeine Charac. des Klimas" in *Hydro. Mitt. vom Hydr. Bur. der Admir.*, Berlin, 1873; Kerhallet's *Descr. de l'Archip. des Açores*, 1851, translated by Totten, 1874.

AZOTUS, the name given by Greek and Roman writers to Ashdod, or Eshdod, an ancient city of Palestine, now represented by a few remains in the little village of Esud, in the pashalik of Acre. It was situated a short distance

inland from the Mediterranean, on the usual military route between Syria and Egypt, about 18 geographical miles N.E. of Gaza. An one of the five chief cities of the Philistines, and the seat of the worship of Dagon, it maintained, down even to the days of the Maccabees, a vigorous, though somewhat intermittent, independence against the power of the Israelites, by whom it was nominally assigned to the territory of Judah. In spite of its being dismantled by Uzziab, and somewhat later, in 731 B.C., captured by the Assyrians, it was strong enough in the next century to resist the assaults of Psammetichus for twenty-nine years. Restored by the Roman Gabinus from the ruins in which it had been left by the Jewish wars, it was presented by Augustus to Salome, the sister of Herod. It became the seat of a bishop early in the Christian era, but seems never to have attained any importance as a town.

AZPEITIA, a town of Spain, in the province of Guipuzcoa, on the left bank of the Urola, 16 miles S.W. of San Sebastian. The neighbouring country is fertile, and quarries of marble are wrought in the mountains. During the Carlist movement in 1870-74, Azpeitia was the seat of the Guipuzcoan *Diputacion*, or court for the management of the war; and gunpowder, cartridges, and cannon were manufactured in the town. The famous monastery of San Ignacio, dedicated to Loyola, about a mile distant, was also appropriated for military purposes. Population stated at 2335.

AZTECS, the native name of one of the tribes that occupied the table-land of Mexico on the arrival of the Spaniards in America. It has been very frequently employed as equivalent to the collective national title of Nahuatlacas, or Mexicana. The Aztecs came, according to native tradition, from a country to which they gave the name of Aztlan, usually supposed to lie towards the N.W., but the satisfactory localisation of it is one of the greatest difficulties in Mexican history. The date of the exodus from Aztlan is equally undetermined, being fixed by various authorities in the 11th and by others in the 12th century. One Mexican manuscript gives a date equivalent to 1164 A.D. They gradually increased their influence among other tribes, until, by union with the Toltecs, who occupied the table-land before them, they extended their empire to an area of from 18,000 to 20,000 square leagues. The researches of Humboldt gave the first clear insight into the early periods of their history. See MEXICO.

AZUNI, DOMENICO ALBERTO, a distinguished jurist and writer on international law, was born at Sassari, in Sardinia, in 1749. He studied law at Sassari and Turin, and in 1782 was made judge of the consulate at Nice. In 1786-88 he published his *Dizionario Universale Ragionato della Giurisprudenza Mercantile*. In 1795 appeared his systematic work on the maritime law of Europe, *Sistema Universale dei Principii del Diritto Marittimo dell'Europa*, of which a second edition was demanded in the following year. A French translation by Digeon was published in 1798, and in 1805 Azuni recast the work, and translated it into French. In 1806 he was appointed one of the French commission engaged in drawing up a general code of commercial law, and in the following year he proceeded to Genoa as president of the court of appeal. After the fall of Napoleon in 1814, Azuni lived for a time in retirement at Genoa, till he was invited to Sardinia by Victor Emmanuel I., and appointed judge of the consulate at Cagliari, and director of the university library. He resided at Cagliari till his death in 1827. Besides the works above mentioned, Azuni wrote numerous pamphlets and minor works, chiefly on maritime law, an important treatise on the origin and progress of maritime law (Paris, 1810), and an historical, geographical, and political account of Sardinia (1st ed. 1799; 2d, much enlarged, 1802).



## B

**B** is the second symbol of all European alphabets except those derived from the Cyrillic original (see ALPHABET, vol. i. p. 615), such as the Russian. In these a modified form, in which only the top of the upper loop appears, stands as the second letter, with the value of the original sound *b*; whilst the old symbol **B** comes third with the phonetic value *v* or *w*. In Egypt this letter was originally a hieroglyph for a crane, and afterwards represented also the sound *b*. The symbol and its phonetic value were borrowed by the Phœnicians, but not its name, as we infer from finding it called in Hebrew *beth*, i. e., a house. In its oldest known Phœnician form the upper loop only exists in a more or less rounded shape. In different alphabets even the upper loop was gradually opened, so that in the square Hebrew the original form can no longer be detected. The Greeks, when they borrowed it from the Phœnicians, closed up the lower loop as well as the upper for convenience of writing. Sometimes the loops were angular, but more generally they were rounded. There is little variation of the form, except in the old alphabets of Corinth and Corcyra, where the original is hardly recognisable. In old Latin both the rounded and the pointed loops appear.

The original sound which this symbol represented, and which it still represents in most European languages, is a closed labial, i. e., one in which perfect closure of the lips is necessary, the sound being heard as the lips open. Like all closed sounds, it is not capable of prolongation. It differs from *p*, which is also a closed labial, as a sonant from a surd. A sonant is heard when the breath, as it passes through the glottis, is vocalised by the tension or approximation of its edges. When there is no such action of the glottis, mere breath alone passes through; but the explosiveness of the breath when the vocal organs are opened produces a sound, and this is called a surd. The vocal organs are in precisely the same position for *p* as for *b*; but in producing *p* they act upon breath only; in producing *b* they articulate voice.

In the earliest stage to which we can trace back the language spoken by the forefathers of the Indo-European nations, it cannot be certainly proved that the sound *b* was ever heard at the beginning of a word. Perhaps in this position it may have been sounded indistinctly as a labial *v*. In English and all Low German languages *p* has taken the place of original *b*, which is preserved in Greek and Latin; thus the *b* in *καρναβας* is replaced by *p* in English "hemp." We do not certainly know the reason of this shifting of sound, which affects all momentary sounds, and which is commonly known in England by the name of "Grimm's law." By the same law English *b* has taken the place of original *β*. Thus our "beech" stands for original "bhaga," which is represented, according to the phonetic laws of the languages, by Greek *βήχος* and Latin "fagus." In the middle of a Latin word, and consequently generally in the languages derived from the Latin, *b* represents original *β*.

There is a tendency among some peoples to allow the *b* sound to pass into a *v*, in which the lips are not firmly closed, and so the sound is capable of prolongation, because it does not consist (as *b* proper does) in the momentary escape of the voice after the lips have been compressed and then opened. This *v*, in the production of which the lips alone are concerned, must be carefully distinguished from our English *v*, which is the result of pressure between the upper teeth and lower lip; it is more like our English *w*.

It is the sound which has taken the place of *b* in modern Greek. The same confusion is found in Latin inscriptions of the 3d and 4th centuries after Christ, when the symbol *v* represents original *b*; thus *sivi* stands for *sibi*, *livido* for *libido* (see Corssen, *Asperrache*, &c., i. 131); and still more frequently *b* appears for *v*, as *bixit* for *visit*. The change would be inconceivable if the symbol *v* in these cases had had the same sound as with us, that of a labiodental. The same indistinctness appeared locally in dialects, as is shown by Martial's well-known epigram—

"Hand temere antiquas mutat Vasconia voces,  
Cui nil est aliud vivere quam biberi."

**BAADER, FRANZ XAVER VON**, an eminent German philosopher and theologian, born 27th March 1765 at Munich, was the third son of F. P. Baader, court physician to the elector of Bavaria. His two elder brothers were both distinguished, the eldest, Clemens, as an author, the second, Joseph, as an engineer. Franz when young was extremely delicate, and from his seventh to his eleventh year was afflicted with a species of mental weakness, which singularly enough disappeared entirely when he was introduced for the first time to the mathematical diagrams of Euclid. His progress thenceforth was very rapid. At the age of sixteen he entered the university of Ingolstadt, where he studied medicine, and graduated in 1782. He then spent two years at Vienna, and returning home, for a short time assisted his father in his extensive practice. This life he soon found unsuited for him, and he decided on becoming a mining engineer. He studied under Werner at Friburg, travelled through several of the mining districts in North Germany, and for four years, 1792–1796, resided in England. There he became acquainted with the works of Jakob Böhme, and at the same time was brought into contact with the rationalistic 18th-century ideas of Hume, Hartley, and Godwin, which were extremely distasteful to him. For Baader throughout his whole life had the deepest sense of the reality of religious truths, and could find no satisfaction in mere reason or philosophy. "God is my witness," he writes in his journal of 1786, "how heartily and how often I say with Pascal, that with all our speculation and demonstration we remain without God in the world." Modern philosophy he thought essentially atheistic in its tendencies, and he soon grew to be dissatisfied with the Kantian system, by which he had been at first attracted. Particularly displeasing to him was the ethical autonomy, or the position that man had in himself a rule of action, that duty contained no necessary reference to God. This Baader called "a morality for devils," and passionately declared that if Satan could again come upon earth, he would assume the garb of a professor of moral philosophy. The mystical, but profoundly religious, speculations of Eckhart, St Martin, and above all of Böhme, were more in harmony with his mode of thought, and to them he devoted himself. In 1796 he returned from England, and in his passage through Hamburg became acquainted with Jacobi, the Faith philosopher, with whom he was for many years on terms of close friendship. He now for the first time learned something of Schelling, and the works he published during this period were manifestly influenced by that philosopher. Yet Baader is no disciple of Schelling, and probably, in the way of affecting the future course of Schelling's thought, gave out more than he received. Their personal friendship continued till about the year 1822, when Baader's vehement denunciation of modern

philosophy in his letter to the Czar of Russia entirely alienated Schelling.

While prosecuting his philosophical researches, Baader had continued to apply himself diligently to his profession of engineer. He gained a prize of 12,000 gulden (about £1000) for his new method of employing Glauber's salts instead of potash in the making of glass. From 1817 to 1820 he held the post of superintendent of mines, and was raised to the rank of nobility for his services. He retired from business in 1820, and soon after published one of the best of his works, *Fermenta Cognitionis*, 6 pts., 1822-25, in which he combats modern philosophy, and recommends the study of J. Böhme. In 1826, when the new university was opened at Munich, he was appointed professor of philosophy and speculative theology. Some of the lectures delivered there he published under the title, *Spekulatives Dogmatik*, 4 pts., 1827-1836. In 1838 he opposed the interference in civil matters of the Roman Catholic Church, to which he belonged, and in consequence was, during the last three years of his life, interdicted from lecturing on the philosophy of religion. He died 23d May 1841.

It is extremely difficult to give in moderate compass an adequate view of Baader's philosophy; for he himself generally either gave expression to his deepest thoughts in brief, obscure aphorisms, or veiled them under mystical symbols and analogies. In this respect his style of exposition is not undeserving of Zeller's strictures (*Ges. d. dest. Phil.*, 732, 736). Further, he has no systematic works; his doctrines were for the most part thrown out in short detached essays, in comments on the writings of Böhme and St Martin, or in his extensive correspondence and journals. For his own part, he was distinctly of opinion that philosophy is not as yet capable of reduction to scientific form, and it would consequently be an error to demand from him a rigidly coherent body of truth. At the same time, the general tendency of his thought is very apparent, and there are some salient points which stand out with a clearness sufficient to render possible an outline of his whole course of speculation. In the mode in which he approaches the problems of philosophy, Baader is entirely opposed to the modern speculative spirit, which, beginning with Descartes, has endeavoured to erect a rational or coherent system on the basis of self-consciousness alone, and has protested against the presupposition of anything which can fetter reason, and against the acceptance of any truth which cannot be rationally construed. He starts from the position that human reason is in a corrupt condition, and by itself can never reach the end it aims at, and maintains that we cannot throw aside the presuppositions of faith, church, and tradition. His point of view may, with some truth, be described as Scholasticism; for, like the great scholastic doctors, he believes that theology and philosophy are not opposed sciences, but that reason has to make clear the truths given by authority and revelation. But in his attempt to draw still closer the realms of nature and of grace, of faith and knowledge, of human thought and divine reason, he approaches more nearly to the mysticism of Eckhart, Paracelsus, and Böhme. All self-consciousness, he thinks, is at the same time God-consciousness; our knowledge is never mere *scientia*, it is invariably *con-scientia*—a knowing with, consciousness of, or participation in God. Of this knowledge, as of knowledge in general, there are three grades:—(1.) Where the thing known impresses itself upon us without or against the will, where the knowledge is necessary,—such, *e.g.*, is the knowledge that God is; (2.) Where the thing known is cognised by an act on our part, where knowledge is free,—such, *e.g.*, is the voluntary belief or trust in God; (3.) Where the thing known enters into, and forms part of, the very process of

knowing,—such is the *speculative* knowledge of God, wherein we recognise that without God we are not, and that we know Him only in and through His knowledge of us. The notion of God is thus the fundamental thought of Baader; his philosophy is in all essentials a theosophy, and its first great problem is to determine accurately the nature of the divine Being. Now God, who is, according to Baader, the primary will which lies at the basis of all things, is not to be conceived as mere abstract Being, *substantia*, but as everlasting process, activity, *actus*. Of this everlasting process, this self-generation of God, we may distinguish two aspects—the immanent or esoteric, and the emanant or exoteric. God has reality only in so far as He is absolute spirit, and only in so far as the primitive will cognises or is conscious of itself can it become spirit at all. But, in this very cognition of self is involved the distinction of knower and known, producer and produced, from which proceeds the power to become spirit. This immanent process of self-consciousness, wherein indeed a trinity of persons is not given but only rendered possible, is mirrored in, and takes place through, the eternal and impersonal idea or wisdom of God, which exists beside, though not distinct from, the primitive will. Concrete reality or personality is given to this divine Ternar, as Baader calls it, through *nature*, the principle of self-hood, of individual being, which is eternally and necessarily produced by God. Only in nature is the trinity of persons attained. These processes, it must be noticed, are not to be conceived as successive, or as taking place in time; they are to be looked at *sub specie eternitatis*, as the necessary elements or moments in the self-evolution of the divine Being. Nor is *nature* to be confounded with created substance, or with matter as it exists in space and time; it is pure non-being, the mere otherness, *aliteritas*, of God—his shadow, desire, want, or *desiderium sui*, as it is called by mystical writers. Creation is itself a free and non-temporal act of God's love and will, and on this account its reality cannot be speculatively deduced, but must be accepted as an historic fact. Created beings were originally of three orders—the intelligent, or angels; the non-intelligent natural existences; and man, who mediated between these two orders. Intelligent beings are endowed with freedom; it is possible, but not necessary, that they should fall. Hence the fact of the fall is not a speculative, but an historic truth. The angels fell through pride—through desire to raise themselves to equality with God; man fell by lowering himself to the level of nature. Only after the fall of man begins the creation of space, time, and matter, or of the world as we now know it; and the motive of this creation was the desire to afford man an opportunity for taking advantage of the scheme of redemption, for bringing forth in purity the image of God according to which he has been fashioned. The physical philosophy and anthropology which Baader, in connection with this, unfolds in various works, is but little instructive, and coincides in the main with the semi-intelligible utterances of Böhme. In nature and in man he finds traces of the dire effects of sin, which has corrupted both, and has destroyed their natural harmony. As regards ethics, it has been already pointed out that Baader rejects the Kantian or any autonomic system of morals. Not obedience to a moral law, but realisation in ourselves of the divine life, through and in which we have our being, is the true ethical end. But man has lost the power to effect this by himself; he has alienated himself from God, and therefore no ethical theory which neglects the facts of sin and redemption is satisfactory or even possible. The history of man and of humanity is the history of the redeeming love of God. The means whereby we put ourselves so in relation with Christ as to receive from Him his healing virtue, are chiefly prayer and

the sacraments of the church, though it must be noted that mere works are never sufficient. With regard to man in his social relations there are two great institutions or systems of rules under which, or in connection with which, he stands. One is temporal, natural, and limited—the state; the other is eternal, cosmopolitan, and universal—the church. In the state two things are requisite: first, common submission to the ruler, which can only be secured or given when the state is Christian, for God alone is the true ruler of men; and, secondly, inequality of rank, without which there can be no organisation. A despotism of mere power, and liberalism, which naturally produces socialism, are equally objectionable. The ideal state is a perfectly organised church society, a civil community ruled by a universal or Catholic church, and the principles of this church are equally distinct from mere passive pietism, or faith which will know nothing, and from the Protestant doctrine, which is the very radicalism of reason.

Baader is, without doubt, the greatest speculative theologian of modern Catholicism, and his influence has extended itself even beyond the precincts of his own church. The great work of Rothe, *Theologische Ethik*, is thoroughly impregnated with his spirit; and, not to mention others, J. Müller, *Christ. Lehre v. der Sünde*, and Martensen, *Christ. Dogmatik*, show evident marks of his influence.

His works have been collected and published by a number of his adherents—Hoffmann, Hamberger, E. v. Schaden, Lutterbeck, Von Outen-Secken, and Schlüter—*Baader's Sämmtliche Werke*, 16 vols., 1851–60. Valuable introductions by the editors are prefixed to the several volumes. Vol. xv. contains a full biography; vol. xvi., an index, and an able sketch of the whole system by Lutterbeck. Among the most valuable works in elucidation or development of Baader's philosophy may be named:—Hoffmann, *Vorhalle zur Spekulationen Lehre Baader's*, 1836; *Grundzüge der Societäts-Philosophie Franz Baader's*, 1837; *Philosophische Schriften*, 3 vols., 1868–72; *Die Weltalter*, 1868; Hamberger, *Cardinalpunkte der Baader'schen Philosophie*, 1855; *Fundamentalbegriffe von F. B's Ethik, Politik, u. Religions-Philosophie*, 1858; Lutterbeck, *Philosophische Standpunkte Baader's*, 1854; *Baader's Lehre vom Weltgebäude*, 1866. The only satisfactory survey in any history of philosophy is that given by Erdmann, *Versuch einer Gesch. d. neuern Phil.*, iii. 2, pp. 538–636. (E. A. D.)

BAAL is a Semitic word, which primarily signifies *lord* or *owner*, and then, in accordance with the Semitic way of looking at family and religious relations, is specially appropriated to express the relation of a *husband* to his wife, and of the *deity* to his worshipper. In the latter usage, which does not occur among the Arabian Semites, the word Baal seems at first to have been a mere title of deity and not a proper name. In the Old Testament it is regularly written with the article—"the Baal;" and the Baals of different tribes or sanctuaries were not necessarily conceived as identical, so that we find frequent mention of Baalim, or rather "the Baalim," in the plural. There is even reason to believe that at an early date the Israelites applied the title of Baal to Jehovah himself, for one of Saul's sons is named Esh-baal (1 Chron. viii. 33), while everything we know of Saul makes it most unlikely that he was ever an idolater. Afterwards, when the name Baal was exclusively appropriated to idolatrous worship (cf. Hos. ii. 16, 17), abhorrence for the unholy word was marked by writing *Boazeth* (shameful thing) for Baal in compound proper names, and thus we get the usual forms Ishboazeth, Mephibozeth. (Cf. Ewald, *Geschichte*, ii. 537, and Wellhausen, *Text der Bücher Samuelis*, pp. xii. 30, where more arguments are adduced for this view.)

The great difficulty which has been felt by investigators in determining the character and attributes of the god Baal mainly arises from the originally appellative sense of the word, and many obscure points become clear if we remember that when the title became a proper name it might be appropriated by different nations to quite distinct deities, while traces of the wider use of the word as a title for any

god, might very well survive even after one god had come to be known as Baal *par excellence*. That Baal is not always one and the same god was known even to the ancient mythologists, who were very much disposed to fuse together distinct deities; for they distinguish an "old" Baal or Belitan (Bel éthan) from a younger Baal, who is sometimes viewed as the son of the other. The "old" Baal has sometimes been identified with the planet Saturn, but it is more likely that he is the Baal (in Assyrian pronunciation Bil) of the first triad of the Babylonian Pantheon, that is the Bel; as distinct from the Baal of the Old Testament. This Assyrian and Babylonian Bel is no mere solar or planetary god, but is represented in Chaldean cosmogony as the shaper of heaven and earth, the creator of men and beasts, and of the luminaries of heaven (*Berosus*, ed. Richter, p. 50). At the same time, we find that the inscriptions give the title of Bel to other and inferior gods, especially to Merodach or the planet Jupiter. This planet was, we know, the Baal (Bál, Bil) of the heathen Mesopotamians (Sabians) of later times, and of the Babylonian Mendeans.

The Baal of the Syrians, Phœnicians, and heathen Hebrews is a much less elevated conception than the Babylonian Bel. He is properly the sun-god, Baal Shamem, Baal (lord) of the heavens, the highest of the heavenly bodies, but still a mere power of nature, born like the other luminaries from the primitive chaos (*Sanchoniathon*, ed. Orelli, pp. 10, 14). As the sun-god he is conceived as the male principle of life and reproduction in nature, and thus in some forms of his worship is the patron of the grossest sensuality, and even of systematic prostitution. An example of this is found in the worship of Baal-Peor (Num. xxv.), and in general in the Canaanitish high places, where Baal, the male principle, was worshipped in association with the unchaste goddess Ashera, the female principle of nature. The frequent references to this form of religion in the Old Testament are obscured in the English version by the rendering "grove" for the word Ashera, which sometimes denotes the goddess, sometimes the tree or post which was her symbol. Baal himself was represented on the high places not by an image, but by obelisks or pillars (*Maccabees*, E. V. wrongly "images"), sometimes called *chammanim* or sun-pillars, a name which is to be compared with the title Baal-chamman, frequently given to the god on Phœnician inscriptions. There is reason to believe that these symbols, in their earliest form of the sacred tree and the sacred stone, were not specially appropriated to Baal worship, but were the mark of any sanctuary, memorials of a place where the worshipper had found God (see, for example, Gen. xxi. 33, where for grove read *tamarisk*, Gen. xxviii. 18), while the stone pillar was also a primitive altar. Gradually, however, they came to be looked upon as phallic symbols, appropriate only to sensual nature worship, and as such were attacked by the prophets (Micah v. 13, 14; Isa. xvii. 8, xxvii. 9, &c.), and destroyed by such orthodox kings as Josiah. The worship of Baal among the Hebrews has two distinct periods—one before the time of Samuel, and a second from the introduction of the Tyrian worship of Baal by Ahab, who married a Phœnician princess. The ritual of this new Baal, with his long train of priests and prophets, his temple and sacred vestments (2 Kings x.), was plainly much more splendid than the older Canaanitish worship. Of the worship of the Tyrian Baal, who is also called Melkart (king of the city), and is often identified with the Greek Heracles, but sometimes with the Olympian Zeus, we have many accounts in ancient writers, from Herodotus downwards. He had a magnificent temple in insular Tyre, founded by Hiram, to which gifts streamed from all countries, especially at the great feasts. The solar character of this deity appears especially in the annual feast of his awakening shortly after

the winter solstice (Joseph., *Ant.*, viii. 5). At Tyre, as among the Hebrews, Baal had his symbolical pillars, one of gold and one of smaragdus, which, transported by phantasy to the Farthest West, are still familiar to us as the pillars of Hercules. The worship of the Tyrian Baal was carried to all the Phœnician colonies. His name occurs as an element in Carthaginian proper names (Hannibal, Asdrubal, &c.), and a tablet found at Marseilles still remains to inform us of the charges made by the priests of the temple of Baal for offering sacrifices.

A much-disputed question is the relation of the sun-god Baal to Moloch-Saturn. Moloch is certainly called Baal in Jer. xix. 5, xxxiii. 35, but the word may here retain its appellative force. It is, however, the theory of many scholars, especially worked out by Movers, that Moloch is only a special development of Baal, representing the destructive heat instead of the life-giving power of the sun. Another question of some nicety concerns the precise character and mutual relations of the female deities associated with Baal. In the Old Testament, as we have seen, Baal is generally associated with Ashera, but sometimes with Ashtoreth or Astarte (in the plural Ashtaroth, associated with the plural Baalim, 1 Sam. vii. 4, &c.) As Ashtoreth is constantly associated with the Phœnician Baal, it was long customary to identify Ashera with her, a theory opposed to the fact that Ashtoreth is represented as a chaste goddess. The key to the difficulty is probably to be sought in the Assyrian mythology, where we find that the planet Venus was worshipped as the chaste goddess Istar, when she appeared as a morning star, and as the impure Bilit or Beltis, the Mylitta of Herod. (l. 199), when she was an evening star. These two goddesses, associated yet contrasted, seem to correspond respectively to the chaste Ashtoreth and the foul Ashera, though the distinction between the rising and setting planet was not kept up among the Western Semites, and the nobler deity came at length to be viewed as the goddess of the moon.

Finally, we may mention as a special form of Baal the Philistine Baal-zebul, or "Baal of flies," a conception which has more than one analogy in Greek religion, especially the Ζεὺς Ἀρούμνος at Olympia. The use of the word Beelzebul, or rather, with a slight change, Beelzebub, by the later Jews, to denote the prince of the devils (Mat. xii. 24), is easily understood on the principle laid down in 1 Cor. x. 20.

For further information as to Baal, the reader may consult works on Syrian and Phœnician religion. Of older books, the most celebrated is Selden's *De diis Syris*; of recent books, Movers's *Die Phœnizier*, i., a work full of learning, but deficient in method and logic. The valuable contributions to the subject from Assyrian research are partly brought together by Schrader in the *Stud. und Krit.* for 1874, pp. 335, *egg.*

(W. R. A.)

**BĀĀLBĒC**, or **BĀ'ĀLBĀK**, an ancient city of Syria, celebrated for the magnificence of its ruins, which, with the exception of those at Palmyra, are the most extensive in that region. The derivation of the latter part of the name is still dubious, some boldly identifying it with the Egyptian *baki*, a city, and others comparing it with the Arabic *bakka*, "to be thronged." It is almost certain that the Greek Heliopolis was intended to be a translation of the name. The town is pleasantly situated on the lowest declivity of the Anti-Libanus, at the opening of a small valley into the plain of El-Bukā'a or Sahlat Bā'albak, about 35 miles N.N.W. of Damascus, and 38 S.S.E. of Tripoli. The inhabitants have a saying, Burton informs us, that it lies on *the balance*, meaning that it occupies the flattened crest of a watershed. By Russegger its height above the sea is given at 3496 Paris feet, and by Schubert at 3572,—the mean of the observations being 3584 Paris feet, or 4502

English feet. A small stream, rising in the immediate neighbourhood from a fountain, known as Ra'as-el Ayn, is employed for the irrigation of the valley.

The origin of Baalbec is lost in remote antiquity, and the historical notices of it are very scanty. The silence of the classical writers respecting it would seem to imply that previously it had existed under another name; and various attempts have been made to identify it with certain places mentioned in the Bible, as with Bealgad, "in the valley of Lebanon" (Josh. xi. 17); Bealath, one of Solomon's cities (1 Kings ix. 18); Baal-hamon, where Solomon had a vineyard (Cant. viii. 11.); and "the plain of Aven" (Bilath-Aven, Amos i. 5), referred to by Amos; but none of these identifications seem to rest on any very solid support, though they have each in turn met the approval of some writer of authority. In the absence of more positive information, we can only conjecture that its situation on the high road of commerce between Tyre and Palmyra and the farther East rendered it at an early period a seat of wealth and splendour. It is not at all improbable that the statement of Macrobinus in his *Saturnalia* may be founded on the tradition of a real and potent connection between Heliopolis and its Egyptian nameake. It is mentioned by Josephus (*Ant.*, xiv. 3, 4), Pliny (*Nat. Hist.*, v. 23), and Ptolemy, and coins of the city have been found belonging to the reigns of almost all the emperors from Nerva to Gallienus. John Malala of Antioch ascribes the erection of a great temple to Jupiter (ὡς τὸ Διὸς μέγαν) at Heliopolis to Antoninus Pius; and two votive inscriptions still exist on the bases of columns in the Greater Temple, belonging to the age of Septimius Severus. From the civic coins of the reigns of Nerva and Hadrian we learn that the city had been constituted a colony by Julius Cæsar, and that it was the seat of a Roman garrison in the time of Augustus, and obtained the *Jus Italicum* from Septimius Severus (Ulpian, *De Censibus*, lib. i.) Some of the coins of this last emperor bear the figure of a temple and the legend COL. HELLIO. M. H., *Colonia Heliopolis Jovi Optimo Maximo Heliopolitano*; while one of the reign of Valerian has the representation of two temples.

It is evident that in the early Christian centuries Heliopolis was one of the most flourishing seats of Pagan worship, and the Christian writers draw strange pictures of the morality of the place. In 297 it became the scene of the martyrdom of Gelasinus. The Emperor Constantine, according to Sozomen, issued a rescript against the licentious rites of the people, and founded a *basilica* among them; but, on the accession of Julian, the Pagan population broke out into violent persecution, and the city became so notorious for its hostility to Christianity, that Christians were banished thither from Alexandria as a special punishment. Theodosius the Great is said to have turned "the temple of *Balanus*, the Trilithon," into a Christian church, and the city seems to have been the seat of a bishop.

From the accounts of Oriental writers, Baalbec seems to have continued a place of importance down to the time of the Moslem invasion of Syria. They describe it as one of the most splendid of Syrian cities, enriched with stately palaces, adorned with monuments of ancient times, and abounding with trees, fountains, and whatever contributes to luxurious enjoyment. After the capture of Damascus it was regularly invested by the Moslems, and after a courageous defence, at length capitulated. The ransom exacted by the conquerors was 2000 ounces of gold, 4000 ounces of silver, 2000 silk vests, and 1000 swords, together with the arms of the garrison. The city afterwards became the mart for the rich pillage of Syria; but its prosperity soon received a fatal blow from the caliph of Damascus, by whom it was sacked and dismantled, and the principal in

habitans put to the sword (748 A.D.) It continued, however, to be a place of military importance, and was frequently an object of contest between the caliphs of Egypt and the various Syrian dynasties. In 1090 it passed into the hands of the Seljuk princes of Aleppo and Damascus, who in 1134 were disputing its possession among themselves, and had to yield in 1139 to the power of Genghis Khan. He held the city till 1145, when it reverted to Damascus, and continued mostly, from that time, to follow the fortunes of that city. During the course of the century it suffered severely from one or more of the earthquakes that visited the district in 1139, 1157, 1170. In 1260 it was taken by the forces of Hulagu, who destroyed the fortifications; but, in the 14th century, it is again described by Abulfeda as enclosed by a wall with a large and strong fortress. Whether it was Baalbec, or, as others say, Cairo, that was, in 1367, the birthplace of Takkieddin Ahmad, the Arabic historian, he appears to have derived the name by which he is best known, El-Makrizi, from one of the quarters of the city. In 1400 it was pillaged by Timur in his progress to Damascus; and afterwards it fell into the hands of the Metawali, a barbarous predatory tribe, who were nearly exterminated when Djessar Pacha permanently subjected the whole district to Turkish supremacy.

The ancient walls of the city are about 4 miles in compass; but the present town is, with the exception of some portions of its Saracenic fortifications and its two mosques, a cluster of mean-looking buildings, which serve only to bring out into greater prominence the grandeur of the neighbouring ruins. These consist of three temples, usually known as the Great Temple (and it well deserves the name), the Temple of Jupiter, Apollo, or the Sun, and the Circular Temple. The Great Temple (*vide* Plan), which would seem at one period to have been a kind of pantheon, is situated on a magnificent platform, which raises it high above the level of the ground, and extends from east to west a distance of about 1100 feet. The portico is at the eastern end, and must have been reached by a grand flight of steps. It is 180, or, including the exedrae or pavilions, 260 feet from north to south. A threefold entrance leads into the first court, which is hexagonal in shape, and measures about 250 feet from corner to corner. A portal 50 feet wide, flanked on each side by a smaller aperture of 10 feet, gives admittance to the great quadrangle, which extends from east to west for 440 feet, and has a breadth of 370, thus including an area of between 3 and 4 acres. On all sides, except the eastern, where the "stately stairs" led up to the temple front, this court was surrounded with exedrae of various dimensions, enclosed by costly pillars, and adorned with numerous statues; but statues and pillars and steps are now all involved in a common confusion. The peristyle of the temple proper was composed of fifty-four columns, the front line consisting of ten and the side line of nineteen each. The height of the shafts was about 63 feet, and their diameter 7 feet at the base and about 5 feet at the top. They were crowned with rich Corinthian capitals, and supported an entablature of 14 feet in height (Col. Chesney says 11 feet 9 inches). Most of them were formed of three blocks, united without cement by strong iron dowels. Only six of these columns still stand at the western end of the southern side—three having fallen since the visit of Wood and Dawkins in 1750. That part of the great platform on which the peristyle rests consists of immense walls built up about 50 feet from the ground, and formed, as may be easily seen on the northern side, of thirteen courses of bevelled stones in alternate layers of longer and shorter blocks. Outside these walls, at a distance of 29½ feet, is another (so-called *substruction*) wall on the north, west, and probably, though concealed by rubbish, also on the east side. This is built of large

stones, and contains three blocks of such extraordinary proportions that the temple acquired from them its ancient name of Trilithon, or "Three-Stone-Temple." These measure respectively 64 feet, 63 feet 8 inches, and 63 feet in length, are 13 feet in height, and have been raised 20 feet from the ground in the western wall. Two underground passages, 17 feet wide and 30 feet high, run from east to west along the sides of the platform of the great quadrangle, and are connected by a transverse tunnel of similar description. They seem, from inscriptions on the walls, to have been tenanted at some time by Roman soldiery.

Slightly to the north of the Great Temple, and agreeing with it in its orientation, is the Temple of the Sun, which is in much better preservation than its neighbour, and, though small in comparison with it, is larger than the Parthenon at Athens. It likewise is built on a plat-

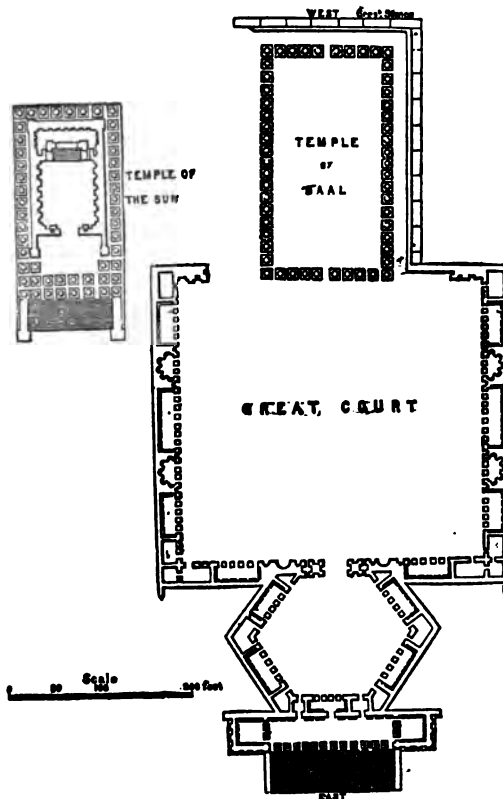

Ground-Plan of Great Temple and Temple of the Sun at Baalbec. (From Wood and Dawkins, *Ruins of Baalbec.*)

form, and was reached by a flight of steps at the eastern end, which, it would seem, were still standing in 1688. The arrangement of its peristyle may be seen from the plan. The height of the columns is 45 feet, including the Corinthian capitals, and the circumference of each 19 feet. They supported an entablature of 7 feet in height, from which a ceiling was carried back to the wall of the *cella*, consisting of alabs enriched with sculpture of great beauty. The principal ornament of each slab is a hexagonal moulding enclosing the figure of some god or hero; but the profusion and elegance of the fretwork can only be rendered by the artist. After passing the vestibule, which was partly freed from its barbarous screen by Mr Burton in

1870, we reach "an exquisitely-carved doorway, having a staircase on each side leading to the top of the building," which gives entrance to the interior of the temple. On the soffit is the figure of the eagle referred to by so many of the travellers, and regarded by Volney and others as the emblem of the sun-god. This part of the building was greatly damaged in the earthquake of 1759, and if measures are not taken to support the lintel, it must soon fall to the ground. The *cella* seems to have been hypæthral; and, like the rest of the building, it was richly ornamented, the floor now presenting a mass of broken sculpture and pillars. A spiral staircase, in the interior of a massive column, leads to the roof on each side of the portal.

Further east stands the Circular Temple, which is of very small dimensions, but of beautiful workmanship and design. It consists of a semicircular *cella* surrounded on the outside by eight Corinthian columns, while within there is a double tier of smaller pillars, the lower row being Ionic and the upper Corinthian. Down to the last century it was used as a Greek church; but it is now in a very ruinous condition, and "choked with wretched hovels." It is known to the people of Baalbec as Barbat-el Atikah (*La Sainte Barbe*).

The remains of the military works of the Saracens and their successors are only too numerous about Baalbec; but they have left no buildings of greater interest than the mosques already mentioned, the larger of which was built by Melek el As'ad, and the smaller by his father, Melek el Zahir (670 A.H.). Several interesting excursions may be made in the neighbourhood, in regard to which the reader may consult Murray's *Handbook*, Joanne and Isambert's *Itinéraire*, and a letter of Mrs Burton's in *Unexplored Syria*.

The ruins of Baalbec have awakened the admiration of European travellers from the 16th century down to the present day. Baumgarten visited them in 1507, Belon in 1548, Thevet in 1550, Melchior von Seydlitz in 1557, Radivil in 1583, Quaresmus in 1620, Monconys in 1647, De la Roque in 1688, and Maundrell in 1699. In the 18th century Pococke gave a sketch of the ruins, which was followed up by the magnificent work of Wood and Dawkins (1751), to this day one of our principal authorities, and Volney, in 1784, supplied a graphic description. During the present century the number of travellers who have visited Baalbec has enormously increased; it may be sufficient to mention Richardson, Addison, Lindsay, Wilson, the Duke of Ragusa, Lamartine, De Saulcy, Chesney, and Robinson. Of the chapters of the last writer, in his *Biblical Researches*, vol. iii., especial use has been made in the present article. In spite, however, of such a series of investigators, much might still be done to extend our knowledge of those wonderful remains. A few superficial excavations have been made from time to time; but the ruins of Baalbec still wait for their Leyard or their Schliemann.

BABATAG, or BABADAG, a city of Turkey in Europe, in the government of Bulgaria and sanjak of Silitria. It stands on the lake or estuary Rassin, which communicates with the Black Sea, and is surrounded by mountains covered with woods. It used to be the winter headquarters of the Turkish army during their wars with Russia; and, in 1854, it was bombarded by the Russians. Long. 28° 32' E., lat. 44° 55' N. The population of 10,000 includes many Jews, Armenians, Tatars, and Greeks. Babatag was founded by Bejazet.

BABBAGE, CHARLES, a distinguished English mathematician and mechanician, was born, 20th December 1792, at Teignmouth in Devonshire. He was educated at a private school, and afterwards entered Trinity College, Cambridge, where he graduated in 1814. Though he did

not compete in the mathematical tripos, he acquired a great reputation at the university. In the year after his graduation he contributed a paper on the "Calculus of Functions" to the *Philosophical Transactions*, and in 1816 was made a fellow of the Royal Society. Along with Herschel and Peacock he laboured to raise the standard of mathematical instruction in England, and specially endeavoured to supersede the Newtonian by the Leibnitzian notation in the Calculus. With this object the three friends translated, in 1816, Lacroix's *Treatise on the Differential and Integral Calculus*, and added, in 1820, two volumes of examples. Mr Babbage's attention seems to have been very early drawn to the number and importance of the errors introduced into astronomical and other calculations through inaccuracies in the computation of tables. He contributed to the Royal Society some notices on the relation between notation and mechanism; and in 1822, in a letter to Sir H. Davy on the application of machinery to the calculation and printing of mathematical tables, he discussed the principles of a calculating engine, to the construction of which he devoted many years of his life. Government was induced to grant its aid, and the inventor himself spent a portion of his private fortune in the prosecution of his undertaking. He travelled through several of the countries of Europe, examining different systems of machinery; and some of the results of his investigations were published in the admirable little work, *Economy of Machines and Manufactures*, 1834, which Blanqui has called "a hymn in honour of machinery." The great calculating engine was never completed; the constructor apparently desired to adopt a new principle when the first specimen was nearly complete, to make it not a difference but an analytical engine, and Government declined to accept the further risk. From 1828 to 1839 Babbage held the office of Lucasian professor of mathematics at Cambridge. He contributed largely to several scientific periodicals, and was instrumental in founding the Astronomical and Statistical Societies. He only once endeavoured to enter public life, when, in 1832, he stood unsuccessfully for the borough of Finsbury. During the later years of his life he resided in London, and, surrounded by his workshops, still continued to devote himself to the construction of machines capable of performing arithmetical and even algebraical calculations. He died at London, 20th October 1871. He gives a few biographical details in his *Passages from the Life of a Philosopher*, 1864, a work which throws considerable light upon his somewhat peculiar character. His works, pamphlets, and papers, were very numerous; in the *Passages* he enumerates eighty separate writings. Of these the most important, besides the few already mentioned, are, *Tables of Logarithms*, 1826; *Comparative View of the Various Institutions for the Assurance of Lives*, 1826; *Decline of Science in England*, 1830; *Ninth Bridgewater Treatise*, 1837; *The Exposition of 1851*, 1851.

BABEL was the native name of the city called Babylon by the Greeks. It means "gate of god," or "gate of the gods," and was the Semitic translation of the original Accadian designation Ca-dimira. According to Gen. xi. 1-9, mankind, after the deluge, travelled from the mountain of the East (or Elwand), where the ark had rested, and settled in Shinar (Sumir, or the north-west of Chaldea). Here they attempted to build a city and a tower whose top might reach unto heaven, but were miraculously prevented by their language being confounded. In this way the diversity of human speech was accounted for; and an etymology was found for the name of Babylon in the Hebrew verb *balbel*, "to confound." According to Alexander Polyhistor (fig. 10) and Abydenus (figs. 5 and 6), the tower was overthrown by the winds. The native version of the story has recently been discovered among the cuneiform

tablets in the British Museum. It is fuller and more complete than the account in Genesis, and formed part of a collection of Babylonian legends older, probably, than 2000 B.C. We learn from it that the tower was erected under the supervision of a semi-divine being called Etanna. The tower has been identified with the temple or tomb of Belus, which Strabo stated with some exaggeration to have been a stade (606 feet) high, but without sufficient reason. It is most probably represented by the modern *Birs Nimrud*, the ruined remains of the "Temple of the Seven Lights of the Earth," at Borsippa, a suburb of Babylon, which was dedicated to Nebo. The temple had been begun by "a former king," and built to the height of 42 cubits, but it lay an uncompleted ruin for many centuries, and was not finished till the reign of Nebuchadnezzar. Dr Schrader believes that the state of wreck in which it so long remained caused "the legend of the confusion of tongues" to be attached to it. The earliest buildings met with in Chaldea are constructed of sun-dried brick and mud. A similar tradition to that of the tower of Babel is found in Central America. Xelhua, one of the seven giants rescued from the deluge, built the great pyramid of Cholula in order to storm heaven. The gods, however, destroyed it with fire and confounded the language of the builders. Traces of a somewhat similar story have also been met with among the Mongolian Tharus in Northern India (*Report of the Census of Bengal*, 1872, p. 160), and, according to Dr Livingstone, among the Africans of Lake Ngami. The Esthonian myth of "the Cooking of Languages" (Kohl, *Reisen in die Ostseeprovinzen*, ii. 251-255) may also be compared, as well as the Australian legend of the origin of the diversity of speech (Gerstaecker, *Reisen*, vol. iv. p. 381, seq.) See further the articles BABYLON and BABYLONIA.

**BAB-EL-MANDEB**, that is, the Gate of Tears, is the strait between Arabia and Abyssinia which connects the Red Sea with the Indian Ocean. It derives its name from the dangers attending its navigation, or, according to an Arabic legend, from the numbers who were drowned by the earthquake which separated Asia and Africa. The distance across is about 20 miles, from Ras Menheli on the Arabian coast to Ras Seyan on the African. The island of Perim, a black and desolate rock, about  $\frac{1}{2}$  miles long by 2 broad, and rising to a height of 240 feet, divides the strait into two channels, of which the eastern and most frequented, known as the Bab Iskender (*Alexander's Strait*), is not more than 4 miles wide, and varies in depth from 7 to 14 fathoms, while the western, or Dact-el-Mayun, has a width of about 15 miles and a depth of 180 fathoms. Near the African coast lie a group of smaller islands known as the Seven Brothers. There is usually a surface outflow from the Red Sea, but a strong under-current must set inwards to compensate not only for this, but for the loss occasioned by the great evaporation. (See Carpenter's "Further Inquiries" in *J. R. Geog. S.*, 1874.) In the end of the 18th century (1799) the island of Perim was taken possession of by the British and held as a military outpost, so to speak, of the Indian empire. They again asserted their right to it in 1857, and in 1861 a lighthouse was built at Straits Point, at the eastern extremity of the island. The harbour is accessible and commodious, and the position gives complete command of the Red Sea.

**BABER**. **ZEHRA-ED-DIN MAHOMED**, surnamed Baber, or the Tiger, the famous conqueror of India and founder of the so-called Moghul dynasty, was born on the 14th February 1483. He was a descendant of Genghis Khan and Timur, and his father, Omar Sheikh, was king of Farghana, a district of Transoxiana, lying east of Samarcand. Omar died in 1495, and Baber, though only twelve years of age, succeeded to the throne. An attempt made by his uncles

to dethrone him proved unsuccessful, and no sooner was the young sovereign firmly settled than he began to meditate an extension of his own dominions. In 1497 he attacked and gained possession of Samarcand, to which he always seems to have thought he had a natural and hereditary right. A rebellion among his nobles robbed him of his native kingdom, and while marching to recover it, his troops deserted him, and he lost Samarcand also. After some reverses he regained both these places, but in 1501 his most formidable enemy, Schaibani Khan, ruler of the Usbeks, defeated him in a great engagement, and drove him from Samarcand. For three years he wandered about trying in vain to recover his lost possessions; at last, in 1504, he gathered some troops, and crossing the snowy Hindu Kush, besieged and captured the strong city of Cabul. By this dexterous stroke he gained a new and wealthy kingdom, and completely re-established his fortunes. In the following year he united with Husain Mirza of Herat against Schaibani. The death of Husain put a stop to this expedition, but Baber spent a year at Herat, enjoying the pleasures of that capital. He returned to Cabul in time to quell a formidable rebellion, but two years later a revolt among some of the leading Moghuls drove him from his city. He was compelled to take to flight, with very few companions, but his great personal courage and daring struck the army of his opponents with such dismay that they again returned to their allegiance, and Baber regained his kingdom. Once again, in 1510, after the death of Schaibani, he endeavoured to obtain possession of his native country. He received considerable aid from Shah Ismael of Persia, and in 1511 made a triumphal entry into Samarcand. But in 1514 he was utterly defeated by the Usbeks, and, with difficulty reached Cabul. He seems now to have resigned all hopes of recovering Farghana, and as he at the same time dreaded an invasion of the Usbeks from the west, his attention was more and more drawn towards India. Several preliminary incursions had been already made, when in 1521 an opportunity presented itself for a more extended expedition. Ibrahim, emperor of Delhi, had made himself detested, even by his Afghan nobles, several of whom called upon Baber for assistance. He at once assembled his forces, 12,000 strong, with some pieces of artillery, and marched into India. Ibrahim, with 100,000 soldiers and numerous elephants, advanced against him. The great battle was fought at Paniput, 21st April 1526, when Ibrahim was slain and his army routed. Baber at once took possession of Agra. A still more formidable enemy awaited him; the Rana Sanga of Mewar collected the enormous force of 210,000 men, with which he moved against the invaders. On all sides there was danger and revolt, even Baber's own soldiers, worn out with the heat of this new climate, longed for Cabul. By vigorous measures and inspiring speeches he restored their courage, though his own heart was nearly failing him, and in his distress he abjured the use of wine, to which he had been addicted. At Kanwah, on the 10th March 1527, he won a great victory, and made himself absolute master of India. The remaining years of his life he spent in arranging the affairs and revenues of his new empire and in improving his capital, Agra. He died 26th December 1530, in his forty-eighth year. Baber was above the middle height, of great strength; and an admirable archer and swordsman. His mind was as well cultivated as his bodily powers; he wrote well, and his observations are generally acute and accurate; he was brave, kindly, and generous. Full materials for his life are found in his *Memoirs*, written by himself (translated into English by Leyden and Erskine, London, 1826; abridged in Caldecott, *Life of Baber*, London, 1844).

**BABEUF**, **FRANÇOIS-NOLÉ**, surnamed by himself

*Gracchus Babeuf*, the earliest of the French socialists, was born in 1762, in the department of Aisne. From his father, a major in the Austrian army, he received special instruction in mathematics, but was deprived of him by death at the age of sixteen. Established as a land-surveyor at Roze, in the Somme department, he became a fervid advocate of the Revolution, and wrote articles in the *Correspondant Picard*, for which he was prosecuted in 1790. He was acquitted on that occasion, and was afterwards elected an administrator of the department; but a charge of forgery being brought against him, he was condemned by the Somme tribunal to twenty years' imprisonment in 1793. Escaping to Paris, he became secretary to the Relief Committee of the Commune, and joined Garin in his denunciation of the Committee of Public Safety. This led to his incarceration, ostensibly under the former sentence. This was, however, annulled by the Court of Cassation; and he was also discharged by the Aisne tribunal (18th July 1794), to which he had been remitted. Returning to Paris, he entered on a violent crusade against the remains of the Robespierre party, and started the *Journal de la Liberté de la Presse* to maintain his views. In the following year (1795) the Girondists acquired supremacy in the Convention; Babeuf's journal was suspended, and himself imprisoned—first in Paris and then at Arras. Thrown into the society of certain partisans of Robespierre, he was won over by them, and was ready, on his release, to become the indiscriminating defender of the very men whom he had previously attacked (No. 34 of the *Tribun*, as he now called his journal). In April 1796 Babeuf, Lepelletier, and others, constituted themselves a "Secret Directory of Public Safety," and took the title of the "Equals;" while another association of self-styled "Conventionals" and "Patriots" met at the house of Amar. The latter party aimed at the re-establishment of the revolutionary government, while Babeuf and his friends wanted besides to realise their schemes for the organisation of common happiness. Disputes naturally arose; and to reconcile the Equals and the Patriots, it was agreed, first, to re-establish the constitution of 1793; and secondly, to prepare for the adoption of true equality by the destruction of the Government. Everything was ready by the beginning of May 1796, and the number of adherents in Paris was reckoned at 17,000; but on the 10th the Government succeeded in arresting the main leaders of the plot. The army protected the Government, and the people of Paris looked on. The trial was opened at Vendôme on Feb. 2, 1797, and lasted three months. Babeuf and Darthé were sentenced to death; Germain, Buonarroti, and five others, to transportation; Amar, Vadier, Duplay, and the remaining fifty-three, were acquitted. On the announcement of the sentence, Babeuf and Darthé stabbed themselves, but the wounds were, not mortal. They passed a frightful night, and next morning were borne bleeding to the scaffold. Ardent and generous, heroic and self-sacrificing, Babeuf had neither solid knowledge nor steadiness of judgment. "The aim of society is happiness, and happiness consists in equality," is the centre of his doctrine. Propagated under the name of Babouvism, it became the germ of contemporary communism. Babeuf's influence was fatal in a threefold way,—because he re-established the memory of Robespierre among French Republicans, connected them with the theories of Rousseau, and paved the way for that school of Socialists which left the lessons of experience and observation for Utopian dreams.

Babeuf's works are—1. *Cadastre perpétuel, dédié à l'Assemblée Nationale*, à Paris, l'an 1789 et le premier de la Liberté Française, in 8vo; 2. *Journal de la Liberté de la Presse*, which appeared from the 25d No. under the title of "*Le tribunal du peuple*," styled by Michalet "*le monument le plus instructif de l'époque*;" 3. *Du Système de Dépopulation, ou la vie et les crimes de Carrier*, par Grac-

chus Babeuf, Paris, an III, in 8vo. See also, in addition to legal documents and the histories of the time, Buonarroti's *Histoire de la Conspiration de Babeuf*, of which there is an English translation by Bronterre, London, 1836.

BĀBI, or BĀBY, the appellation of a remarkable modern sect in Persia, is derived from the title (*bāb*, i.e., gate) assumed by its founder, Seyed Mohammed Ali, born at Shiraz about 1824, according to Count Gobineau, but ten years earlier according to Kasem Beg. Persia, as is well known, is the least strictly Mahometan of all Mahometan countries, the prophet himself occupying an almost secondary place in the popular estimation to his successor Ali, and the latter's sons, Hâssan and Hosein. The cause of this heterodoxy is, no doubt, to be sought in ethnological distinctions, the Aryan Persians never having been able to thoroughly accommodate themselves to the creed of their Semitic conquerors. Their dissatisfaction has found vent partly in the universal homage paid to Ali, and the rejection of the Sunna or great mass of orthodox Mahometan tradition, partly in violent occasional outbreaks, most characteristically of all in the mystical philosophy and poetry of the Sufia, which, under the guise of a profound respect for the externals of Mahometanism, dissolves its rigid Monotheism into Pantheism. Bābism is essentially one of the innumerable schools of Sufism, directed into a more practical channel by its founder's keen perception of the evils of his times. His first appearance in public took place about 1843, when, on his return from a pilgrimage to Mecca and after a prolonged course of meditation in the ruined mosque of Kufa, the scene of Ali's murder, he presented himself in his native city with a journal of his pilgrimage and a new commentary on the Koran. He speedily became engaged in controversy with the mollahs or regular clergy, who, exasperated by the freedom of his strictures on their lives as well as their doctrines, obtained an official decree forbidding him to preach in public, and confining him to his house. The Bab, by which title he was now universally known, complied in appearance, but continued to instruct his disciples in private; his doctrines rapidly assumed more logical consistency, and his pretensions augmented in an equal ratio. He now laid aside the title of Bāb, declaring himself to be the *Nokteh* or Point, i.e., not merely the recipient of a new divine revelation, but the focus to which all preceding dispensations converged. There was little in such a pretension to shock Oriental habits of thought; while the simplicity and elevation of the ethical part of the Bāb's system, united to the charm of his manner and the eloquence of his discourse, rapidly gained fresh proselytes. The most remarkable of these was the Mollah Hussein Bouahrevieh, a man of great erudition and energy of character, who, having come all the way from Khorasaan to hear him, became his convert, and undertook the dissemination of his religion throughout the empire. Two other apostles were speedily added, the appearance of one of whom may almost be said to mark an epoch in Oriental life. It is rare indeed to find a woman enacting any distinguished part in the East, least of all that of a public teacher. Such, however, was the part assumed by the gifted Zerryn Taj (*Crown of Gold*), better known by the appellation of Gourred-Oul-Ayn (*Consolation of the Eyes*), bestowed in admiration of her surpassing loveliness. The third missionary was Mohammed Ali Balfouroushi, a religious man, who had already acquired a high reputation for sanctity. The new religion made rapid progress, and the endeavours of the authorities to repress it eventually produced a civil war. Hussein constructed a fort in the province of Mazanderan, where he defeated several expeditions despatched against him, but at length fell mortally wounded in the moment of victory, and his followers, reduced to surrender by famine, were mostly put to death (1849). Balfour-



ronshi, with a number of his principal adherents, perished in the city of Zendian after an obstinate defence (May 1850). Ere this event had taken place, the Government had proceeded to the execution of the Báb himself, who had now been confined for some time in the fortress of Cherigh, where he is said to have greatly impressed his gaolers by his patience and dignity. He was removed to Tabriz, and all attempts to induce him to retract having failed, he was suspended from the summit of a wall by the armpits in view of the people, along with one of his disciples; the object of this public exposure being to leave no doubt of the reality of his death. A company of soldiers discharged their muskets at the martyrs; but although the disciple was killed on the spot, the bullets merely cut the cords by which the Báb himself was suspended, and he fell to the ground unhurt. With more presence of mind on his part, this apparently miraculous deliverance might have provoked a popular insurrection in his favour; but, bewildered by the fall, instead of invoking the people, he took refuge in a guard-house, where he was promptly despatched. His death was far from discouraging his followers, who recognised as his successor Mirza Yahya, a youth of noble birth. Yahya established himself at Baghdad, where he is or was recently still residing. No new event of importance occurred until 1852, when an attempt of several Bábis to assassinate the Shah led to a ferocious persecution, in which the beautiful Gourred-Oul-Ayn perished with many others. In the opinion of M. Gobineau, this persecution has rather tended to encourage than to repress the sect, which is believed to be widely diffused in Persia at this moment, under the mask of conformity to the established creed. It can only be regarded as an individual symptom of a constantly recurring phenomenon—the essential incompatibility between the religious conceptions of Aryan and Semitic races. The doctrines of Bábism are contained in an Arabic treatise, entitled *Biyan* (the Exposition), written by the Báb himself. It is essentially a system of Pantheism, with additions from Gnostic, Cabbalistic, and even Buddhistic sources. All individual existence is regarded as an emanation from the Supreme Deity, by whom it will ultimately be reabsorbed. Great importance is attached to the number seven, being that of the attributes supposed to be displayed in the act of creation, and to the number nineteen, which mystically expresses the name of the Deity himself, and is, moreover, the sum of the prophets among whom the latest incarnation of the divine nature is conceived to be distributed in the present dispensation. Of these the Báb is chief, but the other eighteen are regarded as no less participants in the divine nature. This sacred college cannot become extinct until the last judgment; the death of any of its members being immediately followed by a reincarnation, as in the case of the Grand Lama. The prophetic character of Moses, Christ, and Mahomet is acknowledged, but they are considered as mere precursors of the Báb. The morality of the sect is pure and cheerful, and it manifests an important advance upon all previous Oriental systems in its treatment of woman. Polygamy and concubinage are forbidden, the veil is disused, and the equality of the sexes so thoroughly recognised that one at least of the nineteen sovereign prophets must always be a female. The other chief precepts of Bábism inculcate hospitality, charity, and generous living, tempered by abstinence from intoxicating liquors and drugs. Asceticism is entirely discountenanced, and mendicancy, being regarded as a form of it, is strictly prohibited.

Our principal authorities on Bábism to this date are Count Gobineau, formerly French *attaché* at Teheran, in his work, *Les Religions*

*et les PhiloSophies dans l'Asie centrale* (Paris, 1865), and an article by Kasem Beg in the *Journal Asiatique* for 1866. These materials have been condensed into a valuable essay, by F. Pillon, in *L'Année PhiloSophique* for 1869. See also the *History of Persia under the Kajar Dynasty*, by R. G. Watson (whose accusations of immorality against the Bábis seem to be founded solely on the misconduct of particular members of the sect); Ethé, *Essays and Studies* (Berlin, 1879); and incidental notices in the travels of Vambéry, Poisk, Figgott, and Lady Sheil. (R. G.)

BABOON, the popular name of apes belonging to the genus *Cynocephalus* of the family *Simiadae*. See *APZ*, vol. ii. p. 152.

BABRIUS, or BARRIAS, or GARRIAS (the original name being possibly Oriental), a Greek fabulist, who wrote, according to Sir G. C. Lewis, shortly before the Augustan age, though dates have been assigned to him from 250 B.C. to 250 A.D. One of his editors, Boissonade, believes that he was a Roman. His name occurs in some of the old grammarians, and a few fragments were ascribed to him. The first critic who made him more than a mere name, was Bentley in his *Dissertation on the Fables of Æsop*. In a careful examination of these prose Æsopian fables, which had been handed down in various collections from the time of Maximus Planudes, Bentley discovered traces of versification, and was able to extract a number of verses which he assigned to Babrius. Tyrwhitt followed up the researches of Bentley, and for some time the efforts of scholars were directed towards reconstructing the metrical original of the prose fables. In 1842, however, M. Mynas, a Greek, the discoverer of the *Philosophoumena* of Hippolytus, came upon a MS. of Babrius in the convent of St Laura on Mount Athos. This MS. contained 123 fables out of the supposed original number, 160. The fables are written in choliambic, i.e., limping or imperfect iambic verse, having a spondee as the last foot, a metre originally appropriated to satire. The style is extremely good, the expression being terse, pointed, and elegant, and the construction of the stories is fully equal to that in the prose versions. The MS. was first published by Boissonade in 1844; afterwards by Lachmann, 1845; by Orelli and Baiter, 1845; by Sir George Cornewall Lewis, 1846; and by Schneidewin, 1853. The genuineness of this collection of the fables was generally admitted by scholars. In 1857 Mynas professed to have discovered at Mount Athos another part containing 94 fables and a proœmium. According to his statement, the monks, who had been willing to sell the MS. containing the first part for a sufficient price, refused altogether to part with the second. He therefore made a copy which was sold to the British Museum, and was published in 1859 by Sir G. C. Lewis. But these fables only purport to be Babrius spoiled, after having passed through the hands of a "diasceust," that is, some late writer who has turned his verses into barbarous Greek and wretched metre. In a Latin dissertation, published in 1861, Professor Conington carefully examined this part, arriving at the conclusion that the fables were metrical versions of the prose stories, executed by some forger who must have been acquainted with Lachmann's conjectures on fragments formerly known. Cobet expresses a similar opinion, but in stronger terms. It is not impossible that the forger was Mynas himself. Sir G. C. Lewis, however, holds that the similarity between the fables and these existing prose versions appears such as might have been produced not by a forger copying from a prose writer, but rather by two grammarians recasting the same work of Babrius. The standard edition of Babrius is that of Sir G. C. Lewis; there is a faithful translation in verse by Davia. For Conington's dissertation see his *Miscellaneous Writings*, vol. ii. pp. 460-491.

## BABYLON—BABYLONIA

**B**ABYLON (the modern *Hillah*) is the Greek form of Babel or Bab-ili, "the gate of god" (or, as it is sometimes written, "of the gods"), which, again, is the Semitic rendering of *Ca-dimira*, the ancient name of the city in the Turanian language of the primitive Accadian population of the country. It is doubtful whether the god meant was Merodach or Anu, Merodach being the patron divinity of Babylon in the Semitic period, and Su-Anna, "the valley of Anu" (Anammalech), being one of its oldest names. Another synonym of the place was *E-ci*, "the hollow," in reference to its situation, and it was also known, down to the latest times, as Din-Tir, "the house of the jungle," though this seems properly to have been the designation of the town on the left bank of the Euphrates. Under the Cassite dynasty of Khammuragas, it received the title of Gan-Duniyas or Gun-Duni, "the Fortress of Duniyas," which was afterwards made to include the neighbouring territory, so that the whole of Babylonia came to be called by this name. Sir H. Rawlinson has suggested that it was the origin of the Biblical Gan Eden, or "Garden of Eden," to which a popular etymology has given a Hebrew form. However this may be, Babylon figures in the antediluvian history of Berosus, the first of his mythical monarchs, Alorus, being a native of it. The national epic of the Babylonians, which grouped various old myths round the adventures of a solar hero, knows of four cities only—Babylon, Erech, Nipur (*Nifer*) or Calneh, and Surippac or Larankha; and according to Genesis x., Babylon was a member of the tetrapolis of Shinar or Sumir, where the Semite invaders of the Accadians first obtained permanent settlement and power. It seems, however, to have ranked below its three sister-cities, among which Erech took the lead until conquered by the Accadian sovereigns of Ur. It was not until the conquest of Khammuragas that Babylon became a capital, a position, however, which it never afterwards lost, except during the Assyrian supremacy. But it suffered severely at the hands of its northern neighbours. Tiglath-Adar drove the Cassi from it, and established an Assyrian dynasty in their place; and after being captured by Tiglath-Pileser I. (1130 B.C.) and Shalmaneser (851 B.C.), it became a dependency of the Assyrian empire in the reign of the son of the latter. The decline of the first Assyrian empire restored Babylon to independence; but it had soon afterwards to submit to the Caldei, and from the reign of Tiglath-Pileser II. to the death of Assur-bani-pal, it was a mere provincial town of Assyria, breaking now and then into fierce revolt under the leadership of the Caldei, and repeatedly taken and plundered by Sargon, Sennacherib, and Assur-bani-pal. Sennacherib, indeed, razed the city to its foundations. After the defeat of Susrub (690 B.C.), he tells us that he "pulled down, dug up, and burned with fire the town and the palaces, root and branch, destroyed the fortress and the double wall, and the temples of the gods and the towers of brick, and threw the rubbish into the Araxes," the river of Babylon. After this destruction it is not likely that much will ever be discovered on the site of Babylon older than the buildings of Kassar-haddon and Nebuchadnezzar. It was under the latter monarch and his successors that Babylon became the huge metropolis whose ruins still astonish the traveller, and which was described by Greek writers. Of the older city we can know but little. The Babylon of Nebuchadnezzar and his father, Nabopolassar, must have suffered when taken by Cyrus; but two sieges in the reign of Darius Hystaspis, and one in the reign of Xerxes, brought

about the destruction of the defences, while the monotheistic rule of Persia allowed the temples to fall into decay. Alexander found the great temple of Bel a shapeless ruin, and the rise of Seleucia in its neighbourhood drew away its population and completed its material decay. The buildings became a quarry, first for Seleucia and then for Ctesiphon, Al Modain, Baghdad, Kufa, Kerbelah, Hillah, and other towns, and our only cause for wonder is that the remains of the great capital of Babylonia are still so extensive.

The principal of these lie on the left bank of the Euphrates, and consist of three vast mounds—the *Babil* or *Mujellib*, the *Kasr*, and the *Amrdm*, which run from north to south; two parallel lines of rampart east and west of them; and an isolated mass, together with a series of elevations separated by the river westward of the *Kasr*,—the whole being surrounded by a triangular rampart. Our two chief authorities for the ancient topography of the city are Herodotus and Ctesias; and though both were eye-witnesses, their statements differ considerably. The city was built, we are told, on both sides of the river, in the form of a square, and enclosed within a double row of high walls. Ctesias adds a third wall, but the inscriptions refer only to two, the inner *enclitic*, called Imgur-Bel, and its *saliku* or outwork, called Nimitti-Bel. Ctesias makes the outermost wall 360 stades (42 miles) in circumference, while according to Herodotus it measured 480 stades (56 miles), which would include an area of about 200 square miles! Pliny (*N. H.*, vi. 26) follows Herodotus in his figures, but Strabo (*xvi.* 1, 5) with his 385 stades, Qu. Curtius (*v.* 1, 26) with his 368 stades, and Clitarchus (*ap. Diod. Sic.*, ii. 7) with 365 stades, agree sufficiently closely with Ctesias. Even the estimate of Ctesias, however, would make Babylon cover a space of about 100 square miles, nearly five times the size of London. Such an area could not have been occupied by houses, especially as these were three or four stories high (*Hdt.*, i. 180). Indeed Q. Curtius asserts (*v.* 1, 27) that even in the most flourishing times, nine-tenths of it consisted of gardens, parks, fields, and orchards. According to Herodotus, the height of the walls was about 335 feet, and their width 85 feet; while Ctesias makes the height about 300 feet. Later writers give smaller dimensions, but it is clear that they have merely tried to soften down the estimates of Herodotus (and Ctesias); and we seem bound, therefore, to accept the statement of the two oldest eye-witnesses, astonishing as it is. But we may remember that the ruined wall of Nineveh was 150 feet high, even in Xenophon's time (*Anab.*, iii. 4, 10, and *cf.* ii. 4, 12), while the spaces between the 250 towers irregularly disposed along the wall of Babylon (*Ctes. ap. Diod.*, ii. 7) were broad enough to allow a four-horse chariot to turn (*Hdt.*, i. 179). The clay dug from the moat had served for the bricks of the wall, which was pierced with 100 gates, all of brass, with brazen lintels and posts. The two inner enclosures were faced with coloured brick, and represented hunting-scenes. Two other walls ran along the banks of the Euphrates and the quays with which it was lined, each containing 25 gates, which answered to the number of the streets they led into. Ferry-boats plied between the landing-places of the gates; and a movable drawbridge (30 feet broad), supported on stone piers, joined the two parts of the city together. At each end of the bridge was a palace; the great palace of Nebuchadnezzar on the eastern side (the modern *Kasr*), which Herodotus incorrectly transfers to the western bank, being the most magnificent of the two. It was surrounded, according to Diodorus (*ii.* 8, 4), by three

walls, the outermost being 60 stades (7 miles) in circuit. The inner walls were decorated with hunting-scenes painted on brick, fragments of which have been discovered by modern explorers. Two of its gates were of brass, and had to be opened and shut by a machine; and Mr Smith has found traces of two libraries among its ruins. The palace, called "the Admiration of Mankind" by Nebuchadnezzar, and commenced by Nabopolassar, overlooked the Ai-ipur-sabu, the great reservoir of Babylon, and stretched from this to the Euphrates on the one side, and from the Imgur-Bel, or inner wall, to the Libil, or eastern canal, on the other. Within its precincts rose the Hanging Gardens, consisting of a garden of trees and flowers on the topmost of a series of arches at least 75 feet high, and built in the form of a square, each side measuring 400 Greek feet. Water was raised from the Euphrates by means, it is said, of a screw (Strab., xvi. 1, 5; Diod., ii. 10, 6). Some of the materials for the construction of this building may have been obtained from the old ruined palace of the early kings, now represented by the adjoining Amram mound. The lesser palace in the western division of the city belonged to Neriglissar, and contained a number of bronze statues.

The most remarkable edifice in Babylon was the temple of Bel, now marked by the *Babli*, on the north-east, as Professor Rawlinson has shown. It was a pyramid of eight square stages, the basement stage being over 200 yards each way. A winding ascent led to the summit and the shrine, in which stood a golden image of Bel 40 feet high, two other statues of gold, a golden table 40 feet long and 15 feet broad, and many other colossal objects of the same precious material. At the base of the tower was a second shrine, with a table and two images of solid gold. Two altars were placed outside the chapel, the smaller one being of the same metal. A similar temple, represented by the modern *Birs Nimrud*, stood at Borsippa, the suburb of Babylon. It consisted of seven stages, each ornamented with one of the seven planetary colours, the azure tint of the sixth, the sphere of Mercury, being produced by the vitrification of the bricks after the stage had been completed. The lowest stage was a square, 272 feet each way, its four corners exactly corresponding to the four cardinal points, as in all other Chaldean temples, and each of the square stages raised upon it being placed nearer the south-western than the north-eastern edge of the underlying one. It had been partly built by an ancient monarch, but, after lying unfinished for many years, like the Biblical tower of Babel, was finally completed by Nebuchadnezzar.

The amount of labour bestowed upon these brick edifices must have been enormous, and gives some idea of the human force at the disposal of the monarch. If any further illustration of this fact were needed, it would be found in the statement made by Nebuchadnezzar in one of his inscriptions (and quoted also from Berosus), that he had finished the Imgur-Bel in fifteen days. The same monarch also continued the embankment of the Euphrates for a considerable distance beyond the limits of Babylon, and cut some canals to carry off the overflow of that river into the Tigris. The great reservoir, 40 miles square, on the west of Borsippa, which had been excavated to receive the waters of the Euphrates while the bed of its channel was being lined with brick, was also used for a similar purpose. The reservoir seems to have been entered by the Arakhtu or Araxes, "the river of Babylon," which flowed through a deep wady into the heart of Northern Arabia, as Wetzstein has pointed out. Various nomad tribes, such as the Nabathæans or the Pekod, pitched their tents on its banks; but, although it is not unfrequently mentioned in early Babylonian history, we hear no more of it after the time of Nebuchadnezzar. It is possible, therefore, that it was drained by the western reservoir. (A. H. S.)

**BABYLONIA AND ASSYRIA.** Geographically, as well as ethnologically and historically, the whole district enclosed between the two great rivers of Western Asia, the Tigris and Euphrates, forms but one country. The writers of antiquity clearly recognised this fact, speaking of the whole under the general name of Assyria, though Babylonia, as will be seen, would have been a more accurate designation. It naturally falls into two divisions, the northern being more or less mountainous, while the southern is flat and marshy; and the near approach of the two rivers to one another, at a spot where the undulating plateau of the north sinks suddenly into the Babylonian alluvium, tends still more completely to separate them. In the earliest times of which we have any record, the northern portion was comprehended under the vague title of Gutium (the *Goyim* of Gen. xiv. 1), which stretched from the Euphrates on the west to the mountains of Media on the east; but it was definitely marked off as Assyria after the rise of that monarchy in the 16th century B.C. Aram-Naharaim, or Mesopotamia, however, though claimed by the Assyrian kings, and from time to time overrun by them, did not form an integral part of the kingdom until the 9th century B.C., while the region on the left bank of the Tigris, between that river and the Greater Zab, was not only included in Assyria, but contained the chief capitals of the empire. In this respect the monarchy of the Tigris resembled Chaldea, where some of the most important cities were situated on the Arabian side of the Euphrates. The reason of this preference for the eastern bank of the Tigris was due to its abundant supply of water, whereas the great Mesopotamian plain on the western side had to depend upon the streams which flowed into the Euphrates. This vast flat, the modern El-Jezireh, is about 250 miles in length, interrupted only by a single limestone range, rising abruptly out of the plain, and branching off from the Zagros mountains under the names of *Sarasur*, *Hamrin*, and *Sinjar*. The numerous remains of old habitations show how thickly this level tract must once have been peopled, though now for the most part a wilderness. North of the plateau rises a well-watered and undulating belt of country, into which run low ranges of limestone hills, sometimes arid, sometimes covered with dwarf-oak, and often shutting in, between their northern and north-eastern flank and the main mountain-line from which they detach themselves, rich plains and fertile valleys. Behind them tower the massive ridges of the Niphates and Zagros ranges, where the Tigris and Euphrates take their rise, and which cut off Assyria from Armenia and Kurdistan. The name Assyria itself originally denoted the small territory immediately surrounding the primitive capital "the city of Asur" (*al Asur*, the Ellasar of Genesis), which was built, like the other chief cities of the country, by Turanian tribes, in whose language the word signified "water-meadow." It stood on the right bank of the Tigris, midway between the Greater and the Lesser Zab, and is represented by the modern *Kalah Sherghat*. It remained the capital long after the Assyrians had become the dominant power in Western Asia, but was finally supplanted by Calah (*Nimrud*), Nineveh (*Nebi Yunus* and *Kouyunjik*), and Dur-Sargina (*Khorsabad*), some 60 miles further north. See NINEVEH.

In contrast with the arid plateau of Mesopotamia, stretched the rich alluvial plain of Chaldea, formed by the deposits of the two great rivers by which it was enclosed. The soil was extremely fertile, and teemed with an industrious population. Eastward rose the mountains of Elam, southward were the sea-marshes and the ancient kingdom of Nituk or Dilvun (the modern Bender-Dilvun), while on the west the civilisation of Babylonia encroached beyond the banks of the Euphrates, upon the territory of the Semitic nomades (or *Suti*). Here stood Ur (now,

*Mugheir*), the earliest capital of the country; and Babylon, with its suburb, Borsippa (*Birs Nimrud*), as well as the two Sipparas (the Sepharvaim of Scripture, now *Mosab*), occupied both the Arabian and Chaldean side of the river. (See BABYLON.) The Araxes, or "River of Babylon," was conducted through a deep valley into the heart of Arabia, irrigating the land through which it passed; and to the south of it lay the great inland fresh-water sea of *Nedjef*, surrounded by red sandstone cliffs of considerable height, 40 miles in length and 35 in breadth in the widest part. Above and below this sea, from Borsippa to Kufa, extend the famous Chaldean marshes, where Alexander was nearly lost (Arrian, *Exp. Al.*, vii. 22.; Strab., xvi. 1, § 12.); but these depend upon the state of the Hindiyah canal, disappearing altogether when it is closed. Between the sea of *Nedjef* and Ur, but on the left side of the Euphrates, was Erech (now *Warka*), which with Nipur or Calneh (now *Nisfer*), Surippac (*Senkerah?*), and Babylon (now *Hillah*), formed the tetrapolis of Sumir or Shinar. This north-western part of Chaldea was also called Gan-duniyas or Gun-duni after the accession of the Cassite dynasty. South-eastern Chaldea, on the other hand, was termed Accad, though the name came also to be applied to the whole of Babylonia. The Caldai, or Chaldeans, are first met with in the 9th century B.C. as a small tribe on the Persian Gulf, whence they slowly moved northwards, until under Merodach-Baladan they made themselves masters of Babylon, and henceforth formed so important an element in the population of the country, as in later days to give their name to the whole of it. In the inscriptions, however, Chaldea represents the marshes of the sea-coast, and Terebon was one of their ports. The whole territory was thickly studded with towns; but among all this "vast number of great cities," to use the words of Herodotus, Cuthah, or Tiggaba (now *Ibrahim*), Chilmad (*Kalwadah*), Is (*His*), and Dur-aba (*Akkertuf*) alone need be mentioned. The cultivation of the country was regulated by canals, the three chief of which carried off the waters of the Euphrates towards the Tigris above Babylon,—the "Royal River," or Ar-Malcha, entering the Tigris a little below Baghdad, the Nahr-Malcha running across to the site of Seleucia, and the Nahr-Kutha passing through Ibrahim. The Pallacopas, on the other side of the Euphrates, supplied an immense lake in the neighbourhood of Borsippa. So great was the fertility of the soil that, according to Herodotus (i. 195), grain commonly returned two hundred-fold to the sower, and occasionally three hundredfold: Pliny, too (*H. N.*, xviii. 17), says that wheat was cut twice, and afterwards was good keep for sheep; and Berosus remarked that wheat, barley, sesame, ochrya, palms, apples, and many kinds of shelled fruit grew wild, as wheat still does in the neighbourhood of Anah. A Persian poem celebrated the 360 uses of the palm (Strab., xvi. 1, 14), and Ammianus Marcellinus (xxiv. 3) states that from the point reached by Julian's army to the shores of the Persian Gulf was one continuous forest of verdure.

Such a country was well fitted to be one of the primeval seats of civilisation. Where brick lay ready to hand, and climate and soil needed only settled life and moderate labour to produce all that man required, it was natural that the great civilising power of Western Asia should take its rise. The history of the origin and development of this civilisation, interesting and important as it is, has but recently been made known to us by the decipherment of the native monuments. The scanty notices and conflicting statements of classical writers have been replaced by the evidence of contemporaneous documents; and though the materials are still but a tithe of what we may hope hereafter to obtain, we can sketch the outlines of the history, the art, and the science of the powerful nations of the Tigris and Euphrates. Before

doing so, however, it would be well to say a few words in regard to our classical sources of information; the only ones hitherto available. The principal of these is Berosus, the Manetho of Babylonia, who flourished at the time of Alexander's conquests (though see Havet, *Mémoire sur la Date des Ecrits qui portent les noms de Bérose et de Manethon*). He was priest of Bel, and translated the records and astronomy of his nation into Greek. His works have unfortunately perished, but the second and third hand quotations from them, which we have in Eusebius and other writers, have been strikingly verified by inscriptions so far as regards their main facts. The story of the flood taken from Berosus, for instance, is almost identical with the one preserved on the cuneiform tablets. Numerical figures, however, as might be expected, are untrustworthy. According to Berosus, ten kings reigned before the Deluge for 120 *saot*, or 432,000 years, beginning with Alorus of Babylon and ending with Otartas (Opartes) of Larankha, and his son Sisuthrus, the hero of the flood. Then came eight dynasties, which are given as follows:—

(1.) 86 Chaldean kings .....	34,030 years.
(2.) 8 Median " .....	224 "
(3.) 11 (Chaldean) " .....	" "
(4.) 49 Chaldean " .....	458 "
(5.) 9 Arabian " .....	245 "
(6.) 45 Assyrian " .....	526 "
(7.) " (Assyrian) " .....	" "
(8.) 6 Chaldean " .....	87 "

Ptolemy's canon (in the *Almagest*) gives the seventh dynasty in full—

(1.) Nabonassar (747 B.C.) .....	14 years.
(2.) Nadioe .....	2 "
(3.) Khinziroe and Poros (Pul) ..	5 "
(4.) Iluloeo .....	5 "
(5.) Mardokempados (Merodach-Baladan).....	12 "
(6.) Arkeanos (Sargon).....	5 "
(7.) Interregnum .....	2 "
(8.) Hagise .....	1 month.
(9.) Belibos (702 B.C.) .....	8 years.
(10.) Assaranadioe (Assur-nadin-sum).....	6 "
(11.) Régebelos .....	1 "
(12.) Mesaimordakos.....	4 "
(13.) Interregnum .....	8 "
(14.) Asaridinos (Essar-haddon).....	13 "
(15.) Saodukhinos (Savul-sum-yucin).....	20 "
(16.) Sinludanos (Assur-bani-pal) .....	22 "

Next to Berosus, the authority of Herodotus ranks highest. His information, however, is scanty, and he had to trust to the doubtful statements of *ciceroni*. Herodotus was controverted by Ctesias of Cnidus, the physician of Artaxerxes Mnemon. But Ctesias mistook mythology for history, and the Ninus and Semiramis, the Ninyas and Sardanapalus, of Greek romance were in great measure his creations. We may yet construct an Assyrian epopee, like the *Shahnameh* of Firdusi, out of his pages, but we must not look to them for history. Other historical notices of Assyria and Babylonia, of more or less questionable value, are to be gathered from Diodorus and one or two more writers, but beyond Berosus and, to a limited extent, Herodotus, our only ancient authority of much value upon this subject is the Old Testament.

*Ethnology and History.*—The primitive population of Babylonia, the builders of its cities, the originators of its culture, and the inventors of the cuneiform system of writing, or rather of the hieroglyphics out of which it gradually developed, belonged to the Turanian or Ural-Altaic family. Their language was highly agglutinative, approaching the modern Mongolian idioms in the simplicity of its grammatical machinery, but otherwise more nearly related to the Ugro-Bulgarian division of the Finnic group; and its speakers were mentally in no way inferior to the Hungarians and Turks of the present day. The country

was divided into two halves, the Sumir (Sungir, or Shnar) in the north-west, and the Accad in the south-east, corresponding most remarkably to the Suomi and Akkara-k, into which the Finnic race believed itself to have been separated in its first mountain home. Like Suomi, Sumir signified "(the people) of the rivers," and just as Finnic tradition makes Kemi a district of the Suomi, so Came was another name of the Babylonian Sumir. The Accadai, or Accad, were "the highlanders" who had descended from the mountainous region of Elam on the east, and it was to them that the Assyrians ascribed the origin of Chaldean civilisation and writing. They were, at all events, the dominant people in Babylonia at the time to which our earliest contemporaneous records reach back, although the Sumir, or "people of the home language," as they are sometimes termed, were named first in the royal titles out of respect to their prior settlement in the country. A survey of the syllabary has led to the conclusion that the first attempts at writing were made before the Accad had descended into the plains and exchanged papyrus as a writing material for clay; other considerations, however, go to show that although the system of writing may have been invented before they had entered Babylonia, it was not completed until after they had done so. In harmony with this, we find Berousus ascribing the culture of "the mixed population of Chaldea" to Oannes and other similar creatures from the Persian Gulf. So far as we can judge, the civilisation of Elam is at least coeval with that of Babylonia, and the capture of Babylon by the Medes, with whom the historical dynasties of Berousus are commonly supposed to begin, must be explained by an Elamite conquest. Media was the Accadian *Adada*, "the land" *par excellencis*; and Accadian tradition looked back upon the mountainous district to the south-west of the Caspian as the cradle of their race. Among these "mountains of the east," and in the land of Nisir (the furthestmost division of Gutium beyond the Lesser Zab), rose "the mountain of the world," the Turanian Olympus, on which the ark of the Chaldean Noah was believed to have rested. From this centre Turanian tribes spread in all directions, meeting Alarodians on the north, and Semites on the south-west. The Aryans had not yet penetrated across the great Sagartian desert. The numerous tribes of Susiana, both civilised and uncivilised, spoke languages more closely Ugrian than even that of the Accadians; the oldest towns of Northern Syria, where the Semite afterwards reigned supreme, bore Accadian names, and, as in the case of Haran, were mythologically connected with Babylon; while the chief cities of Assyria were founded by Accadians, were denoted by Accadian symbols, and were ruled by Accadian princes, in strict accordance with the statement of Genesis that out of Babylonia "went forth Aashur." An Elamite conqueror of Chaldea, like Chedorlaomer (Gen. xiv. 1), imposed his authority not only over Shinar, but over Assyria and Gutium as well. The earliest geographical lists know only of Nuvva, or Elam, on the east, the Khani on the west, Martu, the land of "the path of the setting sun," Subarti, or Syria with its four races, and Gutium, which stretched across Mesopotamia from the Euphrates on the one side to the mountains of Media on the other. To these must be added Anzan, or southern Elam, with its capital Susa, Dilvun, or Nituk, on the Persian Gulf, and, at a considerably later date, the Hittites, with their chief city Carchemish.

The first monarchs whose monumental records we possess had their seat at Ur, on the right bank of the Euphrates. Ur, in Accadian, signified "the city" *par excellencis*, and so bore testimony to the supremacy claimed by its rulers over the rest of Babylonia. The great temple of the Moon-god there was one of the oldest buildings in the country, and its erection was due to a prince who claimed

sovereignty over the whole of Babylonia, and adorned Erech, Nipur, Larsa, and other cities with temples of vast size, dedicated to the sun, to Istar, and to Bel. He seems to have been the first great Babylonian builder; and this would imply that it was under him that Ur rose to its prominent position, and united the numerous principalities of Chaldea under one head. The enormous brick structures were cemented with bitumen in the place of lime mortar; but the use of the buttress, of drains, and of external ornamentation, shows that architectural knowledge was already advanced. The cuneiform system of writing had attained its full development, signet stones were carved with artistic skill, and the amount of human force at the disposal of the monarch may be estimated from the fact that the Bowariyeh mound at Warka, on the site of the temple of the Sun-god, is 200 feet square and 100 feet high, so that above 30,000,000 bricks must have been employed upon its construction. The vicinity of Ur to the Semitic tribes of Arabia implies that the Accadian sovereigns had been turning their attention in that direction, and we find nothing surprising therefore in the Scriptural account of Abraham's migration from this place, or the Phœnician tradition of the original home of the Canaanitish race on the shores of the Persian Gulf (Strab., i. 2, 35, xvi. 3, 4, 27; Justin, xviii. 3, 2; Pliny, *N. H.*, iv. 36). Indeed, we have clear evidence that Semitic was spoken in Ur itself at this remote epoch. Although the ruling caste were Accadian, and generally wrote their inscriptions in that language, Dungi, one of their earliest monarchs, in spite of his Turanian name, has left us a short legend in Semitic; and it is more than probable that the imperial title of "Sumir and Accad" was soon to be assumed to mark a linguistic as well as a geographical distinction. The brick legends of the various viceroys who governed the cities of Chaldea under this dynasty are all, however, in Accadian.

The supremacy of Ur had been disputed by its more ancient rival Erech, but had finally to give way before the rise of Nisin or Karkak, a city whose site is uncertain, and Karkak in its turn was succeeded by Larsa. Elamite conquest seems to have had something to do with these transferences of the seat of power. In 2280 B.C.—the date is fixed by an inscription of Assur-bani-pal's—Cudur-nankhundi, the Elamite, conquered Chaldea at a time when princes with Semitic names appear to have been already reigning there, and Cudur-mabug not only overran "the west," or Palestine, but established a line of monarchs in Babylonia. His son and successor took an Accadian name, and extended his sway over the whole country. Twice did the Elamite tribe of Cassi or Kossæans furnish Chaldea with a succession of kings. At a very early period we find one of these Kossæan dynasties claiming homage from Syria, Gutium, and Northern Arabia, and rededicating the images of native Babylonian gods, which had been carried away in war, with great splendour and expense. The other Cassite dynasty was founded by Khammuragas, who established his capital at Babylon, which henceforward continued to be the seat of empire in the south. The dynasty is probably to be identified with that called Arabian by Berousus,<sup>1</sup> and it was during its domination that Semitic came gradually to supersede Accadian as the language of the country. Khammuragas himself assumed a Semitic name, and a Semitic inscription of his is now in the Louvre. A large number of canals were constructed during his reign, more especially the famous Nahr-Malcha, and an embankment built along the banks of the Tigris. The king's attention seems to have been turned to the subject of irrigation by a flood which overwhelmed the important city of Mullias. His

<sup>1</sup> If so, the number of reigns to be assigned to it, as well as its duration, will have to be corrected, as we know of at least nineteen kings belonging to this Cassite dynasty.

first conquests were in the north of Babylonia, and from this base of operations he succeeded in overthrowing Naram-Sin (or Kim-Acu) in the south, and making himself master of the whole of Chaldea. Naram-Sin and a queen had been the last representatives of a dynasty which had attained a high degree of glory both in arms and in literature. Naram-Sin and his father Sargon had not only subdued the rival princes of Babylonia, but had successfully invaded Syria, Palestine, and even, as it would seem, Egypt. At Agane, a suburb of Sippara, Sargon had founded a library, especially famous for its works on astrology and astronomy, copies of which were made in later times for the libraries of Assyria. Indeed, so prominent a place did Sargon take in the early history of Babylonia, that his person became surrounded with an atmosphere of myth. Not only was he regarded as a sort of eponymous hero of literature, a Babylonian Solomon, whose title was "the deviser of law and prosperity," popular legends told of his mysterious birth, how, like Romulus and Arthur, he knew no father, but was born in secrecy, and placed by his mother in an ark of reeds and bitumen, and left to the care of the river; how, moreover, this second Moses was carried by the stream to the dwelling of a ferryman, who reared him as his own son, until at last the time came that his rank should be discovered, and Sargon, "the constituted king," for such is the meaning of his name, took his seat upon the throne of his ancestors. It was while the Cassite sovereigns were reigning in the south, and probably in consequence of reverses that they suffered at the hands of the Egyptians, who, under the monarchs of the 18th dynasty, were pushing eastward, that the kingdom of Assyria took its rise. Its princes soon began to treat with their southern neighbours on equal terms; the boundaries of the two kingdoms were settled, and inter-marriages between the royal families took place, which led more than once to an interference on the part of the Assyrians in the affairs of Babylonia. Finally, in the 14th century B.C., Tiglath-Adar of Assyria captured Babylon, and established a Semitic line of sovereigns there, which continued until the days of the later Assyrian empire. From this time down to the destruction of Nineveh, Assyria remained the leading power of Western Asia. Occasionally, it is true, a king of Babylon succeeded in defeating his aggressive rival and invading Assyria; but the contrary was more usually the case, and the Assyrians grew more and more powerful at the expense of the weaker state, until at last Babylonia was reduced to a mere apanage of Assyria.

We possess an almost continuous list of Assyrian kings; and, as from the beginning of the 9th century downwards there exists a native canon, in which each year is dated by the *limmu* or *archon eponymos*, whose name it bears, as well as a portion of a larger canon which records the chief events of each eponymy, it is evident that our chronology of the later period of Assyrian history is at once full and trustworthy. Similar chronological lists once existed for the earlier period also, since an inscription of a king of the 14th century B.C. is dated by one of these eponymies; and the precise dates given in the inscriptions for occurrences which took place in the reigns of older monarchs cannot otherwise be accounted for. How far back an accurate chronological record extended it is impossible to say; but astronomical observations were made in Babylonia from a remote period, and the era of Cudur-nankhundi was known, as we have seen, more than 1600 years afterward; while in Assyria not only can Sennacherib state at Bavian that Tiglath-Pileser I. was defeated by the Babylonians 418 years before his own invasion of that country, but the same Tiglath-Pileser can fix 701 years as the exact interval

between his restoration of the temple of Anu and Rimmon at Kalah Sherghat and its foundation by the dependent viceroys of the city of Assur.

This Tiglath-Pileser, in spite of his subsequent defeat by the Babylonians, was one of the most eminent of the sovereigns of the first Assyrian empire. He carried his arms far and wide, subjugating the Moschians, Cossagenians, Uruuianis, and other tribes of the north, the Syrians and Hittites in the west, and the Babylonians (including their capital) in the south. His empire, accordingly, stretched from the Mediterranean on the one side to the Caspian and the Persian Gulf on the other; but, founded as it was on conquest, and centralised in the person of a single individual, it fell to pieces at the least touch. With the death of Tiglath-Pileser, Assyria seems to have been reduced to comparative powerlessness, and when next its claims to empire are realised, it is under Assur-nirari, whose reign lasted from 883 to 858 B.C. The boundaries of his empire exceeded those of his predecessor, and the splendid palaces, temples, and other buildings raised by him, with their elaborate sculptures and rich painting, bear witness to a high development of wealth and art and luxury. Calah, which had been founded by Shalmaneser I. some four or five centuries previously, but had fallen into decay, became his favourite residence, and was raised to the rank of a capital. His son Shalmaneser had a long reign of 35 years, during which he largely extended the empire he had received from his father. Armenia and the Parthians paid him tribute; and under the pretext of restoring the legitimate monarch he entered Babylon, and reduced the country to a state of vassalage. It is at this time that we first hear of the Caldei or Chaldeans,—carefully to be distinguished from the *Cushim* or Semitic "conquerors" of Scripture,—who formed a small but independent principality on the sea-coast. In the west Shalmaneser succeeded in defeating in 854 B.C. a dangerous confederacy, headed by Rimmon idri or Ben-hadad of Damascus and including Ahab of Israel and several Phœnician kings. Later on in his reign he again annihilated the forces of Hazael, Ben-hadad's successor, and extorted tribute from the princes of Palestine, among others from Jehu of Samaria, whose servants are depicted on the black obelisk. The last few years of his life, however, were troubled by the rebellion of his eldest son, which well-nigh proved fatal to the old king. Assur, Arbela, and other places joined the pretender, and the revolt was with difficulty put down by Shalmaneser's second son, Samas-Rimmon, who shortly after succeeded him. Samas-Rimmon (824-811) and Rimmon-nirari (811-782) preserved the empire of Assyria undiminished; but their principal exploits were in Babylonia, which they wasted with fire and sword, and converted into an Assyrian province.

The first Assyrian empire came to an end in 744, when the old dynasty was overthrown by a usurper, Tiglath-Pileser, after a struggle of three or four years. Once settled on the throne, however, Tiglath-Pileser proceeded to restore and reorganise the empire. Babylonia was first attacked; the Assyrian monarch offered sacrifices and set up his court in its chief cities; and the multitudinous Arab tribes who encamped along the banks of the Euphrates were reduced to subjection. The Caldei in the south alone held out, and to them belonged the first four kings given in Ptolemy's canon. Indeed, it may be said that from the invasion of Tiglath-Pileser to the revolt of Nabopolassar, Babylonia ceased to have any separate existence. It was governed by Assyrian kings or the viceroys they appointed, and the only attempts to recover independence were made under the leadership of the "Caldean" chiefs. It becomes nothing more than an important province of Assyria.

The second Assyrian empire differed from the first in its

greater consolidation. The conquered provinces were no longer loosely attached to the central power by the payment of tribute, and ready to refuse it as soon as the Assyrian armies were out of sight; they were changed into satrapies, each with its fixed taxes and military contingent. Assyrian viceroyers were nominated wherever possible, and a turbulent population was deported to some distant locality. This will explain the condition in which Babylonia found itself, as well as the special attention which was paid to the countries on the Mediterranean coast. The possession of the barbarous and half-deserted districts on the east was of little profit; the inhabitants were hardy mountaineers, difficult to subdue, and without wealth; and although Tiglath-Pileser penetrated into Sagartia, Ariana, and Aracosis, and even to the confines of India, the expedition was little more than a display of power. The rich and civilised regions of the west, on the contrary, offered attractions which the politicians of Nineveh were keen to discover. Tiglath-Pileser overthrew the ancient kingdoms of Damascus and Hamath; with its nineteen districts, and after receiving tribute from Menahem (which a false reading in the Old Testament ascribes to a non-existent Pul) in 740, placed his vassal Hoshea on the throne of Samaria in 730 in the room of Pekah. Hamath had been aided by Uziah of Judah; and, on the overthrow of the Syrian city, Judah had to become the tributary of Assyria. Tiglath-Pileser seems to have met with a usurper's fate, and to have fallen in a struggle with another claimant of the throne, Shalmaneser. The chief event of Shalmaneser's reign (727-722) was the campaign against Samaria. The capture of that city, however, was reserved for his successor, Sargon, in 720, who succeeded in founding a new dynasty. Sargon's reign of seventeen years forms an era in later Assyrian history. At the very commencement of it he met and defeated the forces of Elam, and so prepared the way for the future conquest of that once predominant monarchy. He came into conflict, also, with the kingdoms of Ararat and Van in the north; and the policy of the countries beyond the Zagros was henceforth influenced by the wishes of the Assyrian court. But it was in the west that the power of Nineveh was chiefly felt. Syria and Palestine were reduced to a condition of vassalage, Hamath was depopulated, and Egypt, then governed by Ethiopian princes, first came into collision with Assyria. The battle of Raphia in 719, in which the Egyptians and their Philistine allies were defeated, was an omen of the future; and from this time onward the destinies of civilised Asia were fought out between the two great powers of the ancient world. As the one rose the other fell; and just as the climax of Assyrian glory is marked by the complete subjugation of Egypt, so the revolt of Egypt was the first signal of the decline of Assyria. The struggle between the representative states of the East led, as was natural, to the appearance of the Greek upon the stage of history. Sargon claims the conquest of Cyprus as well as Phœnicia, and his effigy, found at Idalium, remains to this day a witness of the fact. Babylonia, however, was the point of weakness in the empire. It was too like, and yet too unlike, Assyria to be otherwise than a dangerous dependency; and its inhabitants could never forget that they had once been the dominant nation. New blood had been infused into them by the arrival of the Caldei, whose leader, Merodach-Baladan, the son of Yacin, called Mardokempados in Ptolemy's canon, had taken advantage of the troubles which closed the life of Tiglath-Pileser to possess himself of Babylonia; and for twelve years he continued master of the country, until in 710 Sargon drove him from the province, and crowned himself king of Babylon. Merodach-Baladan had foreseen the attack, and endeavoured to meet it by forming alliances with Egypt and the principalities

of Palestine. The confederacy, however, was broken up in a single campaign by the Assyrian monarch; Judea was overrun, and Ashdod razed to the ground. Sargon, who now styled himself king of Assyria and Babylon, of Sunir and Accad, like Tiglath-Pileser before him, spent the latter part of his reign in internal reforms and extensive building. A new town, called after his name, was founded to the north of Nineveh (at the modern Kouyunjik), and a magnificent palace was erected there. The library of Calah was restored and enlarged, in imitation of his semi-mythical namesake of Agane, whose astrological works were re-edited, while special attention was given to legislation. In the midst of these labours Sargon was murdered, and his son, Sennacherib, ascended the throne on the 12th of Ab 705 B.C. Sennacherib is a typical representative of the great warriors and builders of the second Assyrian empire, and is familiar to the readers of the Old Testament from his invasion of Judah, which the native monuments assign to the year 701. The check he received at Eltakeh, where he was met by the forces of Egypt and Ethiopia, saved the Jewish king, not, however, before his towns had been ravaged, a heavy tribute laid upon the capital, and his allies in Ascalon and Ekron severely punished. At the commencement of this campaign Sennacherib had reduced Tyre and Sidon, and the overthrow of these centres of commerce caused a transfer of trade to Carchemish. Babylonia had shaken off the yoke of Assyria at the death of Sargon under Merodach-Baladan, who had escaped from his captivity at Nineveh, but was soon reduced to obedience again, and placed under the government of the Assyrian viceroy Belibus. In 700, however, the year after the Judean war, Babylon rebelled once more under the indomitable Merodach-Baladan, and Suzub, another Chaldean. Sennacherib was occupied with a naval war—the first ever engaged in by the Assyrians—against a body of Chaldeans who had taken refuge in Susiana, and the revolt in his rear was stirred up by the Susianian king. But the insurgents were totally defeated; Assur-nadin-sum, Sennacherib's eldest son, was appointed viceroy of the southern kingdom; and the Assyrian monarch felt himself strong enough to carry the war into the heart of Elam, wasting the country with fire and sword. A last attempt, made by the Susianians and the Chaldeans of Babylonia, to oppose the power of Assyria was shattered in the hardly-contested battle of Khaluli. The interregnum, however, which marks the last eight years of Sennacherib's rule in Ptolemy's canon, shows that Chaldea still continued to give trouble and resist the Assyrian yoke.

Meanwhile Sennacherib had been constructing canals and aqueducts, embanking the Tigris, and building himself a palace at Nineveh on a grander scale than had ever been attempted before. His works were interrupted by his murder, in 681, by his two sons, who, however, soon found themselves confronted by the veteran army of Esar-haddon, their father's younger and favourite son. Esar-haddon had been engaged in Armenia; but in January 680 he defeated them at Khanirabbat, and was proclaimed king. Soon afterwards he established his court at Babylon, where he governed in person during the whole of his reign. After settling the affairs of Chaldea his first campaign was directed against Syria, where Sidon was destroyed and its inhabitants removed to Assyria, an event which exercised a profound influence upon Asiatic trade. The most remarkable expedition of his reign was into the heart of Arabia, to the kingdoms of Hus and Buz, 980 miles distant from Nineveh, 280 miles of the march being through arid desert. The Assyrian army accomplished a feat never since exceeded. In the north, also, it penetrated equally far, subjugating the tribes of the Caucasus, receiving the submission of Teispes the Cimmerian, and taking posse-

sion of the copper-mines on the most remote frontiers of Media. All this part of the country was now in the hands of Aryan settlers, and each small town had its independent chief, like the states of Greece. In fact, on two sides, on both north and west, the Assyrian empire was in contact with an Aryan population, and among the twenty-two kings who sent materials for Essar-haddon's palace at Nineveh were Cyprian princes with Greek names. But the most important work of Essar-haddon's reign was the conquest of Egypt, which left the ancient world under the rule of a single power for some twenty years, and by fusing the nations of Western Asia together, broke down their differences, spread an equalised civilisation, and first struck out the idea of universal empire. In 672 B.C. the land of the Pharaohs was invaded, Tirhakah, the Ethiopian, driven beyond its borders, and the country divided into twenty governments. Vain efforts to shake off the Assyrian supremacy were made from time to time; but just as Babylon had to look to the foreign Caldei for the championship of its independence, so Egypt found its leaders in Ethiopian princes. In 669 Essar-haddon fell ill, and on the 12th day of Iyyar in the following year he associated his son, Assur-bani-pal, with him in the kingdom. On his death at Babylon in 667, Assur-bani-pal was left sole king. One of his first acts was to appoint his brother Savul-sum-yucin (Sammugheh) governor of Babylonia.

Assur-bani-pal, the Sardanapalus of the Greeks, was the "great monarch" of ancient Assyria. The empire on his accession was at the height of its glory and magnitude; the treasures and products of the world flowed into Nineveh, and its name was feared from the frontiers of India to the shores of the Ægean. Constant wars asserted the superiority of the Assyrian troops, though they drained the empire of money and men; and the luxury, which had come in like a flood, was sapping the foundations of the national strength. Assur-bani-pal, in spite of his victories, his buildings, and his patronage of literature, left a diminished inheritance to his son; and the military expeditions, formerly conducted by the king in person, were now entrusted to his generals. His first work was to check the southward advance of the Cimmerians, who were thus driven upon Asia Minor, and to quell a revolt that had broken out in Egypt. Two campaigns were requisite to effect this, and meanwhile Gyges of Lydia had sent tribute to the formidable Assyrian monarch. War had also broken out with Elam, which ended, after a long and hard struggle, with the complete conquest of the country. It was divided into two states, each ruled by Assyrian vassals. But soon after this (in 652) the first blow was struck which eventually led to the downfall of the empire. A general insurrection suddenly took place, headed by Assur-bani-pal's own brother, the viceroy of Babylonia. Elam, Arabia, Egypt, and Palestine made common cause against the oppressor. Egypt alone, however, under the guidance of Psammitichus, and with the help of Gyges, succeeded in recovering her independence; the wandering tribes of Northern Arabia, Kedar, Zobah, Nabathæa, &c., were chastised, and summary vengeance taken on Babylonia and Elam. Babylon and Cuthah were reduced by famine (649), Sammugheh was captured and burnt to death, and fire and sword were carried through Elam. After a protracted war, in which Assur-bani-pal was aided by internal dissensions, Shushan was plundered and razed, and the whole of Susiana reduced to a wilderness. This happened in 643.

Assur-bani-pal's buildings were unrivalled for size and grandeur. Assyrian culture reached its culminating point in his reign, and his palaces glittered with the precious metals, and were adorned with the richest sculpture. The library which he formed at Nineveh far surpassed any that

had ever existed before; literary works were collected from all sides; the study of the dead language of Accad was encouraged, grammars and dictionaries were compiled, and learned men of all nations were attracted to the court. Patron of the arts as he was, however, Assur-bani-pal's character was stained by cruelty and sensuality. Under his second name of Sin-inadina-pal, he appears as king of Babylon in Ptolemy's list; and the complete amalgamation of Assyria and Babylonia in the later years of his rule is shown by the appearance of a prefect of Babylon among the Assyrian eponyms. He was succeeded in 625 by his son Assur-ebil-ili. His death was the signal for a general revolt. Nabopolassar, the viceroy of Babylonia, made himself independent; and Assyria, shorn of its empire, was left to struggle for bare existence, until, under Sarcus its last monarch, Nineveh was taken and burnt by the Babylonians and Medes.

The seat of empire was now transferred to the southern kingdom. Nabopolassar was followed in 604 by his son Nebuchadnezzar, whose long reign of forty-three years made Babylon the mistress of the world. The whole East was overrun by the armies of Chaldea, Egypt was invaded, and the city of the Euphrates left without a rival. Until systematic explorations are carried on in Babylonia, however, our knowledge of the history of Nebuchadnezzar's empire must be confined to the notices of ancient writers, although we possess numerous inscriptions which record the restoration or construction of temples, palaces, and other public buildings during its continuance. One of these bears out the boast of Nebuchadnezzar, mentioned by Berosus, that he had built the wall of Babylon in fifteen days. Evil-Merodach succeeded his father in 561, but he was murdered two years after, and the crown seized by his brother-in-law, Nergal-sharezzer, who calls himself son of Bel-suma-icun, "king of Babylon." Nergal-sharezzer reigned four years, and was succeeded by his son, a mere boy, who was put to death after nine months of sovereignty (555 B.C.) The power now passed from the house of Nabopolassar, Nabu-nahid, who was raised to the throne, being of another family. Nebuchadnezzar's empire already began to show signs of decay, and a new enemy threatened it in the person of Cyrus the Persian. The Lydian monarchy, which had extended its sway over Asia Minor and the Greek islands, had some time before come into hostile collision with the Babylonians, but the famous eclipse foretold by Thales had parted the combatants and brought about peace. Croesus of Lydia and Nabu-nahid of Babylonia now formed an alliance against the common foe, who had subjected Media to his rule, and preparations were made for checking the Persian advance. The rashness of Croesus, however, in meeting Cyrus before his allies had joined him, brought about his overthrow; Sardis was taken, and the Persian leader occupied the next fourteen years in consolidating his power in the north. This respite was employed by Nabu-nahid in fortifying Babylon, and in constructing those wonderful walls and hydraulic works which Herodotus ascribes to Queen Nitocria. At last, however, the attack was made; and after spending a winter in draining the Gyndes, Cyrus appeared in the neighbourhood of Babylon. Belshazzar, Nabu-nahid's eldest son, as we learn from an inscription, was left in charge of the city, while his father took the field against the invader. But the Jews, who saw in the Persians monotheists and deliverers, formed a considerable element of the population and army; and Nabu-nahid found himself defeated and compelled to take refuge in Borsippa. By diverting the channel of the Euphrates the Persians contrived to march along the dry river-bed, and enter the city through an unguarded gate. Babylon was taken, and Nabu-nahid shortly afterwards submitted to the conqueror, receiving in return pardon and a residence in



Carmania. He probably died before the end of Cyrus's reign; at all events, when Babylon tried to recover its independence during the troubles that followed the death of Cambyses, it was under impostors who claimed to be "Nebuchadnezzar, the son of Nabu-nahid."

*Art, Science, and Literature.*—Although in art, as in other things, Assyria was but the pupil and imitator of Babylonia, there was yet a marked difference between its development in the two countries, due partly to natural causes. While the Assyrians had stone in abundance, the Babylonians were obliged to import it from a distance. Brick-clay, on the contrary, lay ready at hand, and architecture among them, consequently, took the forms imposed upon it by the use of bricks instead of stone. Where the Assyrians employed sculptured alabaster to ornament their buildings, the Babylonians contented themselves with enamelled bricks and painted plaster. It is a curious proof of the servile dependence of the northern upon the southern kingdom in artistic matters, that the Assyrians continued to make large use of brick up to the downfall of the empire, in spite of the accessibility of stone and the rapid decay of their palaces caused by the employment of the more fragile material. Still, although Assyrian art clung thus unaccountably to the building materials of another country, it did not dispense with its native stone altogether; and speaking broadly, we may say that the architecture of Nineveh is characterised by the use of stone in contradistinction to the brickwork of Babylonia. Sculpture was naturally developed by the one, just as painting was by the other; and the ornamentation which could be lavished on the exterior in Assyria had to be confined to the interior in Chaldea.

Another distinction between the art of the two monarchies arose from the character of their respective populations. Babylonia was essentially a religious country, and its art, therefore, was primarily religious. Nearly all the great edifices, whose ruins still attract the traveller, were temples, and the inscriptions we possess of the Babylonian princes relate almost wholly to the worship of the gods. In Assyria, on the other hand, the temple was but an appendage of the palace, the king among "these Romans of Asia," as Prof. Rawlinson calls them, being the central object of reverence. While the Chaldean temple, with its huge masses of brickwork, rose stage upon stage, each tier smaller than the lower, differently coloured, and surmounted at the top by a chamber which served at once as a shrine and an observatory, the Assyrian palace was erected upon a mound of rubble, with open courts and imposing entrances, though never more than one or two stories high.

Closely connected with this difference in the religious feelings of the two nations was the greater care and attention paid to burial in Babylonia. As yet not a single tomb has been found in Assyria, while sepulchral remains abound in Chaldea. The vast necropolis of Erech astonishes us by the number of its graves, and the potters of Babylonia were largely employed in making clay coffins. The character of Assyrian art being thus secular, and that of Babylonia sacred and sepulchral, necessarily led to a different application and development of it in the two countries.

We must regard Assyrian art as parallel with later Babylonian, both having branched off from Accadian. In Assyria we may trace two or even three periods of development; but our want of materials makes it impossible to do this in the case of later Babylonian. Among neither people, however, did art altogether escape from the swathing-bands of its nursery, although it was never crystallised as in ancient Egypt. The oldest monuments of Accad already display it in all its forms, rude and rudimentary though they may be. The terraced temples of Ur, Erech,

and other places, mount back to the earliest times of Chaldean history, and we find them already adorned with enamelled bricks, which were first coloured, then glazed, and finally baked in the fire. Terra-cotta cones of various hues, imbedded in plaster, were used for external ornamentation, and at Warka (Erech) coloured half-columns are employed for the same purpose,—an ornamentation which recurs in Sargon's palace at Khorsabad, and was the germ of the many kinds of pillars met with in Assyria. The internal walls of the shrine were bright with paint and bronze and gilding; but the brilliant colouring of the Chaldeans was not reproduced in the northern monarchy where more sombre tints were preferred. The huge structures themselves, of burnt and unburnt brick, were supported by buttresses, and the rain was carried off by elaborately-constructed drains, some of which afford us the earliest examples of the arch. A leaden pipe for the same object was found by Mr Loftus at Mugheir (Ur).

Stone, on account of its scarcity, was highly prized, and used only for sculpture and carving. Fragments of the statue of an Accadian king have been brought from Hammam, and a portrait of Merodach-iddin-akhi, the successful opponent of Tiglath-Pileser I. (1120 a.c.), is cut in low relief on a stone now in the British Museum. Like all other Babylonian stone relics, they are of small size, and of hard black granite, and the royal portrait is interesting not only as being one of the few specimens we possess of Babylonian sculpture, but as showing the marked contrast of the Babylonian face to the typically Jewish features of the Assyrians. If larger stones were rare, however, the same cannot be said of smaller ones, which were used as signets and talismans. These were always incised, and though the figures are frequently rude, and still more often grotesque, they are always clearly cut and vigorous. Indeed, it is clear that emery must have been used for the purpose, while many of the carvings are so minute as to suggest the employment of a magnifying-glass. This, however, seems to be out of the question at so early a date as that to which many of the gems belong, although a crystal lens was discovered by Mr Layard at Nimrud. The design on the signet-cylinder of the earliest king of Ur of whom we have any knowledge is of a high order of merit.

Next to gem-cutting, pottery was carried to considerable perfection by the Accadians. Some of their vases and lamps exhibit great beauty of form, and bear evidence of the potter's wheel; though the large majority are made by the hand, and extremely rude. Spirited bas-reliefs in terra-cotta, however, have been exhumed at Senkerah, and some small terra-cotta figures may also be assigned to this early period. Metallurgy was more backward. Stone implements were still in use, although weapons and ornaments of bronze and copper are met with in abundance; and even iron was not unknown. Bronze bowls occur in almost every tomb, sometimes wrought with considerable skill. Metallurgic art, however, attained its highest point in the manufacture of gold objects like ear-rings and fillets. The latter may be compared with the gold head-dresses found by Dr Schliemann in the Troad. This backward state of metallurgy is somewhat remarkable when we consider the skill displayed in the making of textile fabrics. The oldest gems portray the most richly embroidered robes, and it is probable that the muslins and carpets for which Babylonia was afterwards so famous were already a branch of industry.

Art in Assyria developed chiefly, as has been said, on the side of architecture and sculpture. Its first period is best represented by the reign of Assur-nasir-pal, in whose palaces we obtain excellent illustrations of its excellencies and defects. The period is characterised by a simplicity and vigour which shows itself in the bas-reliefs, where the

figures, more especially the animal forms, are spirited and natural beyond anything that we meet with at a later time. Nothing, for instance, can be bolder and more life-like than the lion-hunt depicted on the slabs of Assurnatsir-pal. There is a freedom in the attitude of the animals which evidences a remarkable grandeur of conception. On the other hand, the execution is somewhat heavy, the perspective is worse even than in later works, and the outlines are reproduced with too servile an exactitude. A background, again, is entirely wanting, the attention of the artist being concentrated upon the principal group. In the second period, which extends from the beginning of the second empire to the reign of Esarhaddon, the freshness and boldness of the preceding stage have passed away. The care once exclusively bestowed upon the chief figures is now shared with an elaborate background, and a pre-Raffaellite minuteness prevails throughout the whole. This, added to a total want of perspective, causes too obtrusive a realism. Still, what is lost in vigour is gained in delicacy and finish, and the general effect of such rich and intricate grouping could not but have been effective. The reign of Assur-bani-pal marks the third and last period of Assyrian art. Drawing has made a rapid advance, and the sculptures furnish several instances of successful foreshortening. The art of this period is distinguished by great softness and chasteness; vegetable forms are represented with admirable skill, and the overcrowding of the preceding stage is avoided by recurring to the plain backgrounds of the first period, or introducing merely the main outlines of a landscape. At the same time, it is clear that Assyrian art is beginning to decline; and the freedom and boldness that once marked it tend to disappear, and it is pervaded by a spirit of effeminacy which is well exemplified by the subjects portrayed. For the first time scenes are taken from the harem; the king lies, with his wife seated beside him, banqueting under the shade of the vine; and the lions that Assurnatsir-pal hunted in the open field at the risk of life are now tame creatures, kept in cages, and let out for a royal *battue*, where they have to be whipped into activity.

The effect of this Assyrian bas-relief sculpture was heightened by judicious colouring. Red, blue, black, and white—none of them, however, of very great brilliancy—were laid upon certain parts of the picture, such as the eyes, hair, and fringes of the garments. This partial colouring was also adopted by the Greeks, and it is extremely probable that they borrowed it from Assyria. The beginning of Greek art coincides with the decadence of Assyrian; and the objects found by M. Cesnola and others in Cyprus show us the transition of the one into the other. While the remains found by Dr Schliemann in the Troad do not exhibit any Assyrian influence, the oldest works of art in Greece itself are thoroughly Assyrian in character. Indeed, we can trace the lion-sculpture at Mycenæ through the similar rock-carving at Kumbet, in Phrygia, back to the artists of Nineveh. The lions themselves are Assyrian in all their details, and the pillar against which they rest reappears in the monuments of Assur-bani-pal. Columnar architecture, in fact, obtained a more extensive development in the empire of the Tigris than has ever been the case elsewhere. The half columns of ancient Chaldea germinated into a wonderful variety of elaborate forms. The most peculiar are those which rest with circular pedestals upon the backs of lions, dogs, and winged bulls. The chasteness of Hellenic taste preserved it from this Eastern fantasticness, but the Doric and Ionic pillars had their first home on the banks of the Tigris. There was something in the round firm column which was congenial to the mind of the Assyrian.

Indeed, it may be said that solidity and realism

underlie all Assyrian art. Muscular strength and power of an intensely earthly and human nature is expressed in their bas-reliefs and the colossal bulls that guarded the palace from the entrance of evil spirits. Nowhere else in the world can we find such an embodiment of brute force and unimaginative energy. Not only is Assyrian art valuable as disclosing the genesis of Hellenic, but yet more so as filling up a vacant chapter in the history of aesthetics. The divine calm and mysterious immensity of Egyptian sculpture was not more foreign to the Greek than the stiff unspirituality and coarse vigour of the Assyrians, which found in the lion an appropriate symbol. But the Assyrian artists did not confine themselves to architecture and bas-reliefs. Gem-cutting was carried to high perfection, and even sitting statues of "the great king" were attempted. These, however, were not so successful as the terra-cotta models, some of which are of great beauty. Indeed, the potters' work of Nineveh can quite vie with that of ancient Greece, and their lamps seem to be prototypes of those which we find in the tombs of Athens or Syracuse. Besides porcelain, glass was also manufactured, and though transparent glass does not appear to have been known before the reign of Sargon, coloured glass, with all the tints that we admire in Venetian ware, had long been an article of trade. Metallurgy, again, was a branch of industry in which the Assyrians particularly excelled. Their gold ear-rings and bracelets are admirable both in design and workmanship; their bronze casts are free from the narrowness of their sculptures in stone; and so well were they acquainted with the art of inlaying one metal with another, that our modern artists have been content to learn from them the method of covering iron with bronze. Household furniture, too, gives us a high idea of Assyrian skill. Like gem-cutting, it brought out the Chinese minuteness and accuracy of the people, and the profuse, though tasteless ornamentation of the seats is especially to be noticed.

It is unfortunate that our knowledge of the development of art in the sister kingdom is still so imperfect. As has been said, however, it is characterised by painting rather than sculpture, and the use of brick instead of stone. The few bas-reliefs that exist are small and inferior in execution; but brilliant colouring and a lavish use of the metals made up for this want. The walls were covered with the most costly materials, and "images portrayed with vermilion" excited the admiration of the stranger. The love of bright colours, in contrast with the sober hues of the Assyrian palaces, led also to the cultivation of gardens, and the hanging gardens of Babylon, raised upon tiers of arches, were one of the wonders of the world. The Babylonian had, too, a strong sense of humour. In the engraved gems and metal-work of the southern empire, we miss the finish and minute care of the sister-kingdom, but they are replaced by a spirit of grotesqueness and serio-comedy. In pottery and the manufacture of textile fabrics the Babylonians particularly excelled; their carpets and variegated dresses were highly prized, while their fondness for music was much celebrated. The history of the latter art, however, both in Babylonia and in Assyria, has yet to be traced.

The science of Assyria, like most things else, was derived from Accad. A large number of its technical terms were borrowed from the Turanian, and continued to the last an enduring monument of the debt owed by the Semite to his predecessor. At the same time, he did not remain a mere imitator; science received a development in his hands which might have been looked for in vain from a Turanian race. First and foremost comes the astronomy, for which Babylonia was so famous in the ancient world. Its beginning goes back to the time when the Accadai had not yet descended from their mountain fastnesses. The smith was

fixed above Elam, and not above Babylonia, and "the mountain of the East," the primitive home of the race, was supposed to support the firmament. The shrines on the topmost terraces of the temples were used also as observatories. Ur had its royal observatory, and so probably had the other cities of Chaldea; in Assyria they existed at Assur, Nineveh, and Arbela, and the astronomers-royal had to send in their reports to the king twice a month. At an early date the stars were numbered and named; but the most important astronomical work of the Accadians was the formation of a calendar. This came after the division of the heavens into degrees, since the twelve months (of 30 days each) were named after the zodiacal signs, and would seem to belong to about 2200 B.C. Somewhat strangely, the Accadian calendar appears to have passed to the Assyrians (and through them to the Jews) through the medium of the Aramæans. The year being roughly made to consist of 360 days, intercalary months had to be added, one of them being regularly inserted every six years, and two others being counted in by the priests when necessary. The *ages* of 60 years, the *æer* of 600, and the *æar* of 3600, were merely cycles dependent upon the general mathematical system of the Babylonians, which made 60 the unit, and then multiplied it by the factors of itself. The week of 7 days was in use from an early period; indeed, the names which we still give to the days can be traced to ancient Babylonia; and the seventh day was one of *sulum* or "rest." The night was divided into three watches; but this was afterwards superseded by the more accurate division of the day into 12 *casûs* (of 2 hours each), corresponding to the divisions of the equator, each *casûs* being further subdivided into 60 minutes, and these again into 60 seconds. The sections of the equator contained 30 degrees each—a degree being 60 *aceses* or minutes; but since an astrolabe, now in the Museum, divides each of the 12 sections in the outer circle into 20 degrees, and those in the inner circle into 10 degrees, it is plain that a different system was adopted for astrological purposes. Eclipses were carefully recorded from a very remote epoch, and since some of these are said to have happened "according to calculation," and others "contrary to calculation," their recurrence after a cycle of eighteen years must have been roughly determined. One of the Assyrian reports states that a watch was kept for an eclipse of the sun on the three last days of the month, but that, contrary to expectation, the eclipse did not take place, and we possess notices of eclipses which have been verified by modern astronomers, though antecedent to the era of Nabonassar, with whom, so far as Ptolemy knew, the first record of them began. The chief work on astronomy was one compiled for the library of Sargon of Agane in seventy tablets or books, which went through many editions, one of the latest being now in the British Museum. It was called "the illumination of Bel," and was translated into Greek by Berosus. The catalogue of its contents includes observations on comets, on the pole-star, the conjunction of the sun and moon, and the motions of Venus and Mars. The main purpose, however, of all these Babylonian astronomical observations was an astrological one; to cast a horoscope, or predict the weather, was the chief business of the Chaldean astronomer. Indeed, the patient minuteness of the meteorological observations is most curious, and it was believed that the same weather recurred after a definite number of years. In the later Assyrian period the study became more scientific, and the observatory reports have something of the precision of modern times. But from a much earlier era we obtain interesting tables of lunar longitudes and numerical equivalents of the daily increase and decrease of the moon. As is implied by the attention given to astronomy, mathematics was fairly advanced. The unit was 60, a very convenient

number, especially when used as the denominator of a fraction. A tablet found at Senkereh gives a table of squares and cubes, correctly calculated, from 1 to 60; and a people who were acquainted with the sun-dial, the clepsydra, the lever, and the pulley, must have had no mean knowledge of mechanics. The lens, too, discovered at Nineveh, explains the minuteness of the cuneiform writing on so many of the tablets, and suggests the possibility of artificial aids to the observation of the heavens.

Assyria possessed but little native literature. It was essentially a land of soldiers, and the more peaceful pursuits had their home in Babylonia, where the universities of Erech and Borsippa were renowned down to classical times. It was not until the reign of Assur-bani-pal that any attempt was made to rival Babylon in learning; then for the first time original compositions came from the pens of Assyrian scholars, and works were even written in the dead language of Accad. Syllabaries, together with grammars, dictionaries, and reading-books of Assyrian and Accadian, were drawn up, besides lists of Semitic synonyms. In these grammars and vocabularies lay the germ of comparative philology, and they are otherwise valuable as affording us the earliest native analysis of Semitic speech. But before this closing period of the empire, the Assyrians had been chiefly content to translate the ancient Accadian literature, or re-edit the contents of Babylonian libraries; and the cramping influence of a dead language, in which all the precedents of law and the first principles of science were locked up, could not but make itself felt. Every great city of Chaldea had at least one library, and it was in imitation of this that the royal libraries at Calah, Nineveh, Assur, and elsewhere, were founded. The larger part of the literature was in clay, stamped in minute characters upon baked bricks, *latercula coccilæ* as Pliny calls them; but papyrus was also used, though none of this fragile material has been preserved to our day. In fact, the use of papyrus seems to have preceded that of clay, which was not employed until after the settlement of the Accadians in the plains. The clay tablets or books were arranged in order; and we learn from the catalogue of Sargon's library at Agane (about 2000 B.C.) that each was numbered, so that the student had only to write down the number of the tablet he wanted and the librarian thereupon handed it to him. The subjects of Accadian literary composition were multifarious. Among the most interesting are the hymns to the gods, some of which strikingly resemble the Hebrew psalms in substance as well as in form. Indeed, the parallelism of Hebrew and Assyrian poetry seems to have been borrowed from the Accadians. But the similarity of expression and feeling is no less remarkable. Thus we read in one—(1.) "May god, my creator: take mine hands. (2.) Guide thou the breath of my mouth; guide thou mine hands; (3.) O lord of light!" and in another—(1.) "In heaven who is high! Thou alone, thou art high. (2.) In earth who is high! Thou alone, thou art high. (3.) As for thee, thy word in heaven is declared: the gods bow their faces to the ground. (4.) As for thee, thy word in earth is declared: the spirits of earth kiss the ground;" or in a third—(1.) "O Lord, my transgressions are many: great are my sins. (2.) The Lord in the anger of His heart: has confounded me. (3.) God in the strength of His heart: set himself against me." A collection was afterwards made of these hymns, which was used for ritualistic purposes, and regarded as an inspired volume, and has been aptly compared by M. Lenormant with the Rig-Veda of the Hindus. Of an older date is the collection of magic formulæ and charms, chiefly intended to counteract the effects of sorcery and demoniac possession, which go back to the Shamanistic period of Accadian religion. Later than the hymns, but still prior to the second millennium B.C. and

the formation of the calendar, are the mythological poems which grew out of the development of a solar worship and the personification of the attributes of the gods. Two of these poems we possess intact,—on the Deluge and the descent of Istar into Hades,—and part of a third which describes the war of the seven evil spirits against the moon. The first two form the sixth and eleventh books of a very remarkable epic which centred round the adventures of a solar hero, older and originally independent lays being woven into it as episodes. The epic was divided into twelve books, each book dealing with a legend appropriate to the name of the corresponding zodiacal sign. This astronomical basis of the national epic shows how thoroughly the study had penetrated the mind of the people; and the clearness with which we can trace the growth and formation of the whole work throws great light on the history of epic literature generally, and adds one more confirmation to the theory of Wolf. The Assyrians also had their epic, in imitation of the Accadians, and M. Lenormant has pointed out that the Semiramis and Nannarus of the Greeks and the other personages of Otesias were really figures of this mythical epopee. The historical and chronological works that have been preserved are of purely Assyrian origin, though there is every reason to suppose that when the libraries of Accad come to be excavated similar compositions will be found in them. The legal literature of the Accadians was certainly very extensive, and a collection of fables, one a dialogue between the ox and the horse, and another between the eagle and the sun, has been met with.

*Language, Law, and Trade.*—As above stated, the language of the primitive Sumirian and Accadian population of Assyria and Babylonia belonged to the Turanian or Ural-Altaic family of speech. The Semitic tribes, who first possessed themselves of the tetrapolis of Sumir or Shinar, and then gradually spread over the whole of Assyria and Babylonia, borrowed many words from their more civilised predecessors, and lent them a few others in return. The so-called Assyrian language is sub-divided into the two dialects of Assyria and Babylonia, the latter dialect being characterised by a preference for the softer sounds, and a fuller use of the vowels. Literature and the influence of a dead language stereotyped it to such an extent that it underwent comparatively little change during the 1500 years during which we can watch its career; at least this is the case with the literary dialect. The closest affinities are with Hebrew and Phœnician; it shares their peculiarities in phonology, grammar, and vocabulary; and some obscure points in Hebrew etymology have already been cleared up by its help. Next to Hebrew, it shows perhaps the greatest resemblance to Arabic; differing most widely, on the other hand, from Aramaic. Aramaic, however, from becoming the *lingua franca* of trade and diplomacy after the fall of Tyre and Sidon, ended (like Arabic in later times) in superseding its sister idioms; but in Babylonia this did not happen until after the Persian conquest.

A large number of the legal precedents of an Assyrian judge, like the titles upon which he had to decide, went back to the Accadian epoch. A table of early Accadian laws shows us that the mother occupied the same prominent place as among modern Turanian tribes. The son is punished with a fine for denying his father, but with banishment for denying his mother. On the other hand, the husband can divorce the wife upon payment of a pecuniary compensation, while the wife who repudiates her husband is condemned to be drowned. The life and person of the slave are already under the protection of the state, the master who misuses him being subject to a fine, while the slave could purchase his freedom. The rights of property, however, were strictly guarded by the

law; the maximum of interest seems also to have been defined; and houses, land, or slaves could be taken as security for a debt. The carefulness with which deeds were signed and attested, and adjudicated cases reported, the deeds and cases being afterwards enclosed in an envelope of clay on which the names and main points were inscribed, testifies to a wide-spread study of law. Witnesses and contracting parties generally affixed their seals; but where they were too poor to possess any, a nail-mark was considered sufficient. In the Accadian period a father could assign property to his son during his lifetime, though he could not put him in possession; and in later times a limited power of willing was in existence. The private will of Sennacherib, in which he bequeaths certain treasures to his favourite son Essar-haddon, is one of the most curious documents of antiquity; unlike other persons, the monarch does not require any witnesses. Great activity of trade is evidenced by this development of law. But here again we must note a distinction due to situation between the northern and southern kingdoms. Of the Chaldeans, it is emphatically said that "their cry was in their ships," and we have many indications of early commerce with the southern coast of Arabia. The trade of Assyria, on the other hand, was wholly overland; and its first fleet was the one built by Phœnician captives for Sennacherib, when pursuing the fugitive Chaldeans through the Persian Gulf. Like the Jews, however, the Assyrians showed an aptitude for trade from the very first. The earliest Semitic settlements in Babylonia seem to have been mainly for commercial purposes, and their career there may be compared with that of the English in India. In the 12th century B.C. the trading spirit had so thoroughly pervaded them that not only were objects of utility and art a marketable commodity, but we find Tiglath-Pileser I. bringing trees from the countries he had overrun, and acclimatising them in Assyria. The fullest development of business and commerce, however, does not show itself until the 8th and 7th centuries B.C., when Nineveh was a busy centre of trade. Sidon and Tyre had been ruined by the Assyrian kings—indeed, it is very possible that the obstinate wars with the Phœnician cities had their origin in commercial jealousy, and trade had accordingly transferred itself to Carchemish, which was conveniently situated on the Euphrates. The maneh of Carchemish became the standard of weight, and Aramaic the common language of trade. The interest upon money was usually at 4 per cent.; but sometimes, more especially when objects like iron were borrowed, at 3 per cent. Payment might still be made in kind; but more ordinarily in bars of the three chief metals, which were weighed, though mention of coined money also occurs. Houses could be let on lease, and the deeds which conveyed them give a careful inventory of the property and its appurtenances. Commercial relations extended from India on the one side, whence came ivory and the teak found at Mr'gheir, which Sennacherib probably means by "wood of Sinda," to the tin islands of Cornwall on the other.

*Religion and Mythology.*—The earliest religion of Accad was a Shamanism resembling that of the Siberian or Samoyed tribes of to-day. Every object had its spirit, good or bad; and the power of controlling these spirits was in the hands of priests and sorcerers. The world swarmed with them, especially with the demons, and there was scarcely an action which did not risk demoniac possession. Diseases were regarded as caused in this way, and the cherubs, bulls, and other composite creatures which guarded the entrance to a house, were believed to protect it from mischief. In course of time certain spirits (or rather denied powers of nature) were elevated above the rest into the position of gods; and at the head of all stood the

Triad of Na or Anna, "the sky," Ea, "the earth," and Mulge, "the lord of the underworld." The old Shamanism gradually became transformed into a religion with a host of subordinate semi-divine beings; but so strong a hold had it upon the mind, that the new gods were still addressed by their spirits. The religion now entered upon a new phase; the various epithets applied to the same deity were crystallised into fresh divinities, and the sun-god under a multitude of forms became the central object of worship. This inevitably led to a mythology, the numerous personified attributes passing into demi-gods and heroes. A large part of the Accadian mythology was solar, and the transparency of its proper names which, as in other agglutinative languages, never disguise their primitive meaning, makes it valuable in verifying the so-called "solar theory" of comparative mythology. At this stage of development, however, an important change passed over the old faith. The Semitic settlers in Sumir had adopted the Accadian pantheon and belief, and after a conflict between the discordant religious conceptions of the two races, a great sacerdotal "reform" took place analogous to that of Brahmanism, and the official religion fused them into one whole. The magicians were taken into the priestly body, and the hierarchy of divine beings was determined. The old triad of Na, Ea, and Mulge became the trinity of Anu, Ea, and Bel the Demiurge, all children of Zicu or Zicara, "the sky" (the Signe of Nicolaus Damascenus); Ea, "the god of life and knowledge," "the lord of the abyss," "the king of rivers and the garden," the husband of Bahu (the Bohu of Gen i. 2), whose spirit pervades the universe, being made the father of Bel-Merodach, the tutelary divinity of Babylon. In accordance with the genius of the sex-denoting Semitic idioms, each deity was furnished with a female principle, and "The god" in Babylonia, and the personified city of Assur, with his wife Serua, in Assyria, were placed at the head of the Pantheon. Below these four supreme divinities came a second trinity of the Moon-god, Sun-god, and Air-god, and the seven together formed "the seven magnificent deities." After these were arranged "the fifty great gods," and then the 300 spirits of heaven, and the 600 spirits of earth, among whom was found a place for the primeval divinities of Accad as well as for the many local deities of Chaldea. The most dreaded of "the spirits of earth" were "the seven spirits" who were born "without father and mother" in the encircling abysses of ocean, and carried plague and evil over the earth. An old myth told of their war against the moon, which was deputed to watch over the interests of mankind.

Along with the establishment of the Babylonian official religion, an astro-theology was created by the introduction of astronomy into the religious sphere. The "spirits" of the various stars were identified with the gods of the new creed, Merodach, for instance, properly one of the forms of the sun-god, being identified with the planet Jupiter, and the five planetary deities were added to the seven magnificent gods, making up altogether "the twelve chiefs of the gods." The elaboration of this astro-theology was also accompanied by the formation of a cosmogony. The details of the latter are to be found in the fragments of Berossus and Nicolaus Damascenus, whose statements are confirmed by the inscriptions, and they show a remarkable resemblance to the cosmogonies of Genesis and Phœnicia. It must be remembered that both Phœnicians and Hebrews profess to have migrated from Chaldea.

The resemblance is still more striking when we examine the Babylonian mythology. The sacred tree of Babylonia, with its guardian "cherubs"—a word, by the way, which seems of Accadian origin—as well as the flaming sword or thunderbolt of fifty points and seven heads, recall Biblical analogies, while the Noachian deluge differs but slightly

from the Chaldean one. Indeed, the Jehovistic version of the flood story in Genesis agrees not only in details, but even in phraseology with that which forms the eleventh lay of the great Babylonian epic. The hero of the latter is Tam-si or Tammuz, "the sun of life," the son of Ubaratutu, "the glow of sunset," and denotes the revivifying luminary of day, who sails upon his "ark" behind the clouds of winter to reappear when the rainy season is past. He is called Sisuthrus by Berossus, that is, Suaru "the founder," a synonym of Na "the sky." The mountain on which his ark rested was placed, as already noticed, in Nisir, south-west of Lake Urumiyeh. Its peak, whereon the first altar was built after the deluge, was the legendary model after which the *sigurats* or towers of the Babylonian temples were erected. Besides the account of the flood, fragments have been met with of stories resembling those of the tower of Babel or Babylon, of the creation, of the fall, and of the sacrifice of Isaac,—the latter, by the way, forming probably the first lay of the great epic. The sixth lay we possess in full. It describes the descent of Istar into Hades in pursuit of her dead husband Dū-si, "the offspring," the Babylonian Adonis. Dū-si is but another form of Tam-si, and denotes the sun when obscured by night and winter. At each of the seven gates of Hades the goddess left some portion of her apparel, until she at last reached the abode of the dead, dark and joyless, where dust alone is the food of the unhappy shades. In the midst rose the golden throne of the spirits of earth, beneath which welled "the waters of life," and here, too, was the seat of Bahu. Bahu, as queen of the underworld, smote Istar with many diseases, and confined her in Hades until her brother the Sun-god complained to the Moon-god and Ea, who sent a sphinx to pour the waters of life upon the imprisoned goddess and restore her to the light of day. This myth gives a good idea of the Chaldean conception of the next world. Certain favoured individuals, however, might look forward to a happier state of existence. A psalm which invokes blessings upon the king wishes him everlasting life in "the land of the silver sky," where the gods feast and know no evil. It will be observed that the Babylonian Hades (like the Hebrew Sheol) is not very dissimilar to the Homeric one; and the possibility of borrowing on the part of the Greeks is suggested by the fact, that the seven-headed serpent of Hindu legend is of foreign origin, being taken from the seven-headed serpent of the Accadians, "which lashes the waves of the sea," while the story of Andromeda came through Phœnician hands from a Chaldean myth which forms the subject of one of the lays of the great epic. So, too, the Oceanus of Homer finds its prototype in the encircling abyssal waters of Accadian geography, and the *fravashis* and *mithras* of Mazdaism were introduced by the Magian (or Turanian) population found in Media by the Aryan invaders.

But the old Shamanistic ideas survived also in Assyria and Babylonia, and so were handed on to the Jews. An elaborate system of augury flourished down to the last days of the empire, and omens were drawn from every event that could possibly happen. Magic formulæ for warding off the attacks of demons were extensively used, and the bronze bowls found by Mr Layard, as well as the part played by charms and demons in the Talmud, show how strongly the belief had seized upon the Jewish mind. Through the Jews and the various Gnostic systems of early Christianity, the primitive doctrines of Accad found their way into the mediæval church, and the features of the mediæval devil may be traced in an Assyrian bas-relief, where a demon with horns, claws, tail, and wings, is being pursued by the god Adar. Even the phylacteries of the Jews go back to the same origin. Accadian magic ordered the sorcerer to bind the charm, twice knotted with seven

knots, round the limbs of the sick man, and this, with the further application of holy water, would, it was believed, infallibly produce a cure, while the same result might be brought about by fixing "a sentence out of a good book on the sufferer's head as he lay in bed." Similar superstitions may yet be detected in the corners of our own land, and still more on the Continent, where the break with the traditions of the past has been less strongly felt. They form an important element in the history of the human intelligence, and the light thrown upon their origin and

early fortunes by the revelations of cuneiform discovery has opened a new chapter in the science of religion.

For Babylon and Babylonia see Rich's *Babylon and Persopolis*, and two memoirs on Babylon; Layard's *Ninesch and Babylon*; Loftus's *Chaldea and Susiana*; Rawlinson's *Five Great Monarchies*; Oppert's *Expédition Scientifique en Mésopotamie*, and *Pastes de Sargon*; Mélan's *Annales des Rois d'Assyrie*; Lenormant's *Premières Civilisations*, and *La Magie chez les Chaldéens*; Schrader's *Keilinschriften und das Alte Testament*; *Records of the Past*; and the *Transactions of the Society of Biblical Archaeology*. (A. H. S.)

**BACCARAT**, a town of France, in the department of Meurthe and arrondissement of Lunéville. It has a large export trade of timber, planks wheelwright's work, and charcoal, and is celebrated for the products of its glassworks, which were established in 1765. Population, 4763.

**BACCHIGLIONE**, a river of north-eastern Italy, which, rising in the mountains eastward of Trent, passes by Vicenza and Padua, and, after a course of 90 miles, falls into the lagune of Venice, south of Chioggia. It is navigable for large boats as far as Vicenza and is connected with the Adige by means of a canal. The river is probably the ancient *Togisonus*.

**BACCHUS**, the Latin name of Dionysus, the god of wine. See **DIONYSUS**.

**BACCHYLIDES**, *Βακχύλιδης*, a famous Greek lyric poet, born at Iulis in Ceos, was the nephew of Simonides, and flourished about 470 years before Christ. He resided long at the court of Hiero of Syracuse with Simonides and Pindar, of whom he is said to have been the rival. His works consisted of odes, dithyrambs, and hymns. Two epigrams contained in the Greek *Anthology* ascribe to him peculiar softness and sweetness of style. The few remains of his writings are contained in the collections of Brunck, Bergk, Bland, and Hartung. They have been published separately by Neue, *Bacchylidis Cei Frag.*, Berl., 1823.

**BACCIO DELLA PORTA**, called **FRA BARTOLOMEO DI S. MARCO**, a celebrated historical and portrait painter, was born at Savignano, near Florence, in 1469, and died in 1517. He received the first elements of his artistic education from Cosimo Roselli; and after leaving him, devoted himself to the study of the great works of Leonardo da Vinci. Of his early productions, which are distinguished for their grace and beauty, the most important is the fresco of the Last Judgment, in which he was assisted by his friend, Mariotto Albertinelli. While he was engaged upon some pieces for the convent of the Dominican friars, he made the acquaintance of Savonarola, who quickly acquired great influence over him, and Baccio was so affected by his cruel death, that he soon after entered the convent, and for some years gave up his art. He had not long resumed it, in obedience to his superior, when the celebrated Raffaello came to Florence and formed a close friendship with him. Bartolommeo learned from the younger artist the rules of perspective, in which he was so skilled, while Raffaello owes to the *frate* the improvement in his colouring and handling of drapery, which was noticeable in the works he produced after their meeting. Some years afterwards he visited Rome, and was struck with admiration and a feeling of his own inferiority when he contemplated the masterpieces of Michel Angelo and Raffaello. With the latter, however, he remained on the most friendly terms, and when he departed from Rome, left in his hands two unfinished pictures which Raffaello completed. Bartolommeo's figures had generally been small and draped. These qualities were alleged against him as defects, and to prove that his style was not the result of want of power, he painted the magnificent figure of St Mark, and

the undraped figure of St Sebastian. The latter was so well designed, so naturally and beautifully coloured, and so strongly expressive of suffering and agony, that it was found necessary to remove it from the place where it had been exhibited in the chapel of a convent. The majority of Bartolommeo's compositions are altar-pieces, and few of them are to be met with out of Tuscany. They are remarkable for skill in the massing of light and shade, richness and delicacy of colouring, and for the admirable style in which the drapery of the figures is handled, Bartolommeo having been the first to introduce and use the lay-figure with joints.

**BACH, JOHANN-SEBASTIAN**, was born at Eisenach in Thuringia, on March 21, 1685, the same year which gave birth to his great contemporary Handel. His father held a musical appointment from the town council, being himself descended from a musician. The family of the Bachs, like those of some of the great Italian painters, may be cited as one of the most striking instances of hereditary artistic genius. Through four consecutive generations they followed the same calling, counting among their number no less than fifty musicians of more or less remarkable gifts. Even of the first ancestor of the family known to us, a miller and baker, who, owing to religious persecutions, had to leave Pressburg in Austria for the Protestant north of Germany, we are told that in his leisure hours he was fond of playing the lute, the sounds of which, as the old family chronicle naively adds, must have mixed sweetly with the clattering of the wheels of his mill. The accumulated artistic gifts and traditions of his forefathers were at last brought to their highest development by the genius of our master, who again transmitted them to his numerous sons. Johann-Sebastian's parents died before he had reached his tenth year, and he was left to the care of his elder brother, an organist at Ohrdruf, from whom he received his rudimentary musical education. According to a tradition the elder Bach was by no means pleased with the rapid progress of his more gifted brother, and even refused him access to the sources of knowledge available at that primitive period; he was particularly anxious to withhold from him a certain collection of compositions for the pianoforte, by contemporary masters, which, however, the younger Bach contrived to obtain surreptitiously, and which he copied at night in the course of six months. By practising the music thus become his own on the pianoforte, he made himself master of the *technique* of an instrument, the capabilities of which he was destined to enlarge and develop by the works of his own genius. In 1698 his brother died, and Bach, at the age of fourteen, saw himself thrown on his own resources for his further means of support. He went to Lüneburg, where his beautiful soprano voice obtained him an appointment as chorister at the school of St Michael. In this manner he became practically acquainted with the principal works of vocal music, continuing at the same time his practice on the organ and pianoforte. A special teacher of any of these instruments, or, indeed, of the theory of music, Bach seems never to have had, at least,

not to our knowledge, and his style shows little affinity to the modes of expression in use before him. In some measure, indeed, it may be said that he new-created his own style, and, at the same time, that of modern music in general, a proof both of the originality of his power and of the autodidactic kind of his training. Nevertheless, Bach was anxious to profit by the examples of contemporary masters of his art. We hear of frequent trips to the neighbouring cities of Hamburg, Lübeck, and Celle, at that time important centres of artistic life. In the first-mentioned city Keiser created sensation by the unrivalled splendour of his operatic productions, while at Lübeck the celebrated organist, Buxtehude, excited the enthusiastic admiration of the young art-aspirant. In Celle, on the other hand, a celebrated band, composed chiefly of French artists, offered an opportunity for the practical study of orchestral music. Such were the elements of his self-education, to which must be added his thorough knowledge of Palestrina and other masters of the grand old Italian school, of most of whose works Bach possessed copies written with his own hand.

At the age of eighteen Bach returned to Thuringia, where his executive skill on the organ and pianoforte attracted universal attention, and even obtained him various musical appointments, of which we mention as the most important that of court organist to the duke of Weimar. One, and not the least welcome, of his official duties was the composition of sacred music. One of his most beautiful sacred cantatas, *Ich hatte viel Bekümmernis*, was composed during his stay at Weimar. An amusing incident of his otherwise quiet and eventless career also belongs to this time. We are speaking of his musical combat with the celebrated French organist, J. Louis Marchand, who had reached Dresden on his travels, and lorded it over his artistic colleagues at the Saxon court in the most sublime manner. The injured musicians, in their endeavours to humble the pride of the Frenchman, at last hit upon the idea of proposing a competition on the organ between him and Bach, whose fame at that time had begun to spread far beyond his place of residence. He was summoned to Dresden, and the day of the tournament fixed, at which the court and all the musical celebrities of the town were to be present. At first Marchand treated his young and comparatively unknown rival with scorn, but on hearing him perform at a preparatory meeting, he was so struck with Bach's power that he ignominiously quitted the field, and vanished from Dresden before the day of the contest arrived. This triumph led to Bach's appointment as musical conductor (*Kapellmeister*) to the duke of Köthen, which he held from 1717-1723, after a previous stay at Weimar for nearly nine years. In 1723 he removed to Leipzig, where the position of cantor at the celebrated "Thomasschule," combined with that of organist at the two principal churches of Leipzig, was offered to him. It was here that the greater part of his works were composed, mostly for the immediate requirements of the moment. Several of them he engraved himself, with the assistance of his favourite son, Friedemann. The further course of his life ran smoothly, only occasionally ruffled by his altercations with his employers, the town-councillors of Leipzig, who, it is said, were shocked by the "unclerical" style of Bach's compositions, and by his independent bearing generally. He was married twice, and had by his two wives a family of eleven sons and nine daughters. In 1747 Bach made a journey to Potsdam by the invitation of Frederick the Great, who, himself a musical amateur, received the master with distinguished marks of regard. He had to play on the numerous pianofortes of the king, and also to try the organs of the churches of Potsdam. Two years

after this event his sight began to fail, and before long he became perfectly blind, a circumstance which again coincides with the fate of his great contemporary, Handel. Bach died of apoplexy on the 28th July 1750. His loss was deplored as that of one of the greatest organists and pianoforte players of his time. Particularly his powers of improvisation are described as unrivalled by any of his contemporaries. Of his compositions comparatively little was known. His MS. works were at his death divided amongst his sons, and many of them have been lost in the course of time; only about one-half of his greater works were recovered, when, after the lapse of nearly a century, the verdict of his neglectful contemporaries was reversed by an admiring posterity.

The history of this Bach revival is closely connected with the name of Mendelssohn, who was amongst the first to proclaim by word and deed the powers of a genius almost too gigantic to be grasped by the receptivity of one generation. By the enthusiastic endeavours of Mendelssohn, Schumann, and others, the circle of Bach's worshippers has increased rapidly. In 1850, a century after his death, a society was started for the correct publication of all of Bach's remaining works, to which music owes the rescue from oblivion of some of its sublimest emanations. Amongst those who have vastly contributed to establish the rapport between our master's genius and modern lovers of art, we also mention Dr Robert Franz, himself one of Germany's greatest lyrical composers, who has edited and adapted to the resources of the modern orchestra several of Bach's most beautiful works. Of these works, comprising almost all the different forms of music, vocal and instrumental, barring the opera, we can enumerate only the most important ones, referring the reader for further information to the biographical and critical works by Bach's son, Philipp Emmanuel, by Forkal, and more recently by Bitter and Spitta. The last-mentioned book has appeared quite lately, and exceeds its predecessors both by comprehensiveness of research and critical appreciation. Of his numerous and sacred oratorios, cantatas, and similar choral works, we name the so-called Christmas oratorio (1734), the Passion music to the words of St John, and that infinitely grander to the gospel of St Matthew (1734), also his Mass in B minor, one of the greatest masterpieces of all times, and the Magnificat in D. Another cantata is constructed on Luther's grand chorale, *Ein feste Burg*. The most celebrated amongst his pianoforte compositions is the so-called *Welltemperirte Clavier*, a collection of preludes and fugues in the different keys of the scale. For the orchestra we name the *Grande Suite in D*, and for his favourite instrument, the organ, the so-called *Chromatic Fantasia*. It remains to add a few words about Bach's position in the history of musical development. By Marx, a well-known critical writer, he has been called the "Founder and Father of German Music;" and it cannot be denied that no other German composer before him had attained a specifically national type of musical utterance as distinguished from that of other nations. This applies both to matter and manner. Bach has frequently founded his grandest conceptions on the simplest tune of old chorales, that is, of purely popular effusions of pious fervour, such as had survived in the living memory of the nation from the time of Luther and his great revival of religious feeling. Sometimes these tunes were adapted for religious purposes from still older songs of a secular character, being thus thoroughly interwoven with the inmost feeling of the German people. In raising these simple creations of popular growth to the higher sphere of art, Bach has established his claim to the name of the creator of the *Germanic* as opposed to the *Romanic* phase of musical art. This spirit of German, or to speak more

accurately, North German nationality, thoughtful yet *naïve*, earnest yet tender, has also reacted on the form of Bach's creations. Bach's counterpoint, compared with the polyphonic splendour of Palestrina or Orlando di Lasso, is, as it were, of a more intense, more immediately personal kind. In his sacred cantatas, the alternate exclamations of the voices sometimes rise to an almost passionate fervour of devotion, such as is known only to the more individualised conception of human relations to the Deity peculiar to Protestant worship,—applying that term in a purely emotional, that is, entirely unsectarian sense. It is thus that Bach has vivified the rigid forms of the fugue with the fire of individual passion. About the peculiarities of his style, from a technical point of view, we can speak no further. How his style and his genius, neglected by his contemporaries, and obscured by other masters, like Haydn and Mozart, starting from a different basis and imbued with a different spirit, have ultimately been destined to exercise a potent spell on modern art, we have indicated already.

(F. H.)

BACH, KARL PHILIPP EMMANUEL, second son of the above, was born at Weimar on the 14th March 1714, and died at Hamburg on the 14th September 1788. He was perhaps the most highly gifted musician of the eleven brothers, and his influence on the development of certain musical forms gives him a prominent place in the history of the art. He studied at the Thomasschule and afterwards at the university of Leipsic, devoting himself, like several of his brothers, to jurisprudence. In 1738 he took up his residence in Berlin, where he was soon afterwards appointed chamber musician to Frederick the Great. In 1767 he was allowed, after considerable negotiation, to relinquish his situation at court in order to accept the post of kapellmeister at Hamburg, where he passed the last twenty-one years of his life. He was a very prolific composer, his most ambitious work being the oratorio of *The Israelites in the Wilderness*. The majority of his compositions, however, were naturally written for his instrument, the clavier. His *Versuch über die wahre Art das Klavier zu spielen* (Essay on the true method of harpsichord playing) was long a standard work, and Clementi professed to have derived from Bach his distinctive style of pianoforte playing. Haydn is said to have acknowledged in his old age his deep obligation to the works of Philipp Emmanuel Bach. From them he certainly learned the form of the sonata and symphony, of which Bach may fairly claim to have been the originator, though Haydn enriched it and gave it permanence. This fact gives Bach's name a distinction to which the intrinsic merits of his compositions might not entitle him, it being now generally agreed by the best critics that he was a somewhat feeble imitator of his father's style.

BACHE, ALEXANDER DALLAS, a distinguished American physicist, who has gained a wide reputation as superintendent of the great American Coast Survey, was a great-grandson of Benjamin Franklin, and was born at Philadelphia, 19th July 1806. In 1821 he entered the military academy at West Point, and graduated there with the highest honours in 1825. For some time he acted as assistant professor in the academy, holding at the same time a commission as lieutenant of engineers, in which capacity he was engaged for a year or two in the erection of coast fortifications. He occupied the post of professor of mathematics in the university of Pennsylvania from 1827 to 1836, and was then made president of the newly-instituted Girard College. In this capacity he undertook a journey through some of the principal countries of Europe, in order to examine their systems of education, and on his return published a very valuable report. In 1843, on the death of Professor Haasler, he was appointed by

Government to the office of superintendent of the coast survey. He succeeded in impressing Congress with a sense of the great value of this work, and by means of the liberal aid it granted, he carried out a singularly comprehensive plan with great ability and most satisfactory results. By a skilful division of labour, and by the erection of numerous observing stations, the mapping out of the whole coast proceeded simultaneously under the eye of the general director. Nor were the observations confined to mere description of the coast-line; the several stations were well supplied with instruments, and a vast mass of magnetic and meteorological observations was collected, such as must infallibly prove of infinite service in the future progress of physical science. The annual reports issued by the superintendent were admirable specimens of such summaries, and secured for him a high reputation among European savants. Professor Bache contributed numerous papers to scientific journals and transactions, and laboured earnestly to raise the position of physical science in America. For some months before his death, which took place at Newport, 17th February 1867, he was afflicted with softening of the brain, caused, perhaps, by intense and long-continued mental exertion.

BACHELOR, a word of various meaning, and of exceedingly obscure origin. In modern times the most common significations of it are—(1), an unmarried person; (2), one who has taken the lowest degree in any of the faculties at a university. At various times, however, it has signified either a young man in general, from which the first of the modern meanings was easily developed; or a knight who was unable to lead a body of retainers into the field, *i.e.*, to use the technical phrase, was not able *lever bannière*; or, finally, an ecclesiastic at the lowest stage of his course of training. It has also been pointed out that *bachelor*, which meant the body of aspirants to knighthood, came to be used as synonymous with *gentry*.

Etymology gives little help in arranging these meanings so as to discover the unity underlying them. In mediæval Latin the word *baccalaria* (connected by Ducange with *vasseleria*, by Stubbs with *bacca*, *i.e.*, *vacca*, a cow), which, according to Diez, is peculiar to the south of France and the north of Spain, signified a certain portion of land, the size and tenure of which imposed on the possessor certain feudal duties. The possessor was called *baccarius*, and the name readily acquired the signification of one who, from poverty or other cause, as youth, was not able to take rank as a knight. As a third stage in the use of the word, Diez marks out the application of it to denote the lowest degree in a university. But though these transitions from the primitive meaning may perhaps appear natural, there is no historic evidence of their having taken place. The same applies to the five meanings given in Ducange.

We look with more prospect of success to the old French words *bacelle*, *baecote*, *bachelette*, *bachelerie*, *bachelage*, which have all the meaning of youth, apprenticeship. They may possibly be connected with the Celtic or Welsh words, *bach*, little, *bachgen*, a boy. (See Wedgwood, *s.v.*, who is of opinion that the *baccarius* of the north of Spain is not in any way connected with our word *bachelor*.) It is very probable that this is truly the root of the word. It has, however, been frequently connected with *baculus*, a stick, from which is supposed to have come *bacularius*, as the word used often to be spelled. (See *Pron:ptorium Parvulorum*, *s.v.*) Whether the relation in this case is that of *shooting forth* or *budding* (*cf.* the Portuguese *backarel*, a twig of vine, and Barbazan's derivation from *baccalia*), or the more obvious one suggested by the functions of the *bacularius*, who appears to have acted as the monitor or preceptor at schools (see H. T. Riley, *Chronica Monasterii St Albani*), is very doubtful.



Bachelors, or unmarried persons, have in many countries been subjected to penal laws. The best-known examples of such legislation are those of Sparta and Rome. At Sparta, citizens who remained unmarried after a certain age were subjected to a species of *trypsis*. They were not allowed to witness the gymnastic exercises of the maidens; and during winter they were compelled to march naked round the market-place, singing a song composed against themselves, and expressing the justice of their punishment. The usual respect of the young to the old was not paid to bachelors (Plut., *Lyc.*, 15). At Athens there was no definite legislation on this matter; but certain minor laws are evidently dictated by a spirit akin to the Spartan doctrine (see Schömann, *Gr. Alterth.*, i. 548). At Rome, though there appear traces of some earlier legislation in the matter, the first clearly known law is that called the *Lex Julia*, passed about 18 B.C. It does not appear to have ever come into full operation; and in 9 A.D. it was incorporated with the *Lex Papia et Poppæa*, the two laws being frequently cited as one, *Lex Julia et Papia Poppæa*. This law, while restricting marriages between the several classes of the people, laid heavy penalties on unmarried persons, gave certain privileges to those citizens who had several children, and finally imposed lighter penalties on married persons who were childless. In Britain there has been no direct legislation bearing on bachelors; but, occasionally, taxes have been made to bear more heavily on them than on others. Instances of this are the Act (6 and 7 Will. III.) passed in 1695; the tax on servants, 1785; and the income tax, 1798.

**BACHIAN**, one of the East Indian islands belonging to the group of the northern Moluccas, situated immediately south of the equator, and lying with its subordinate islands, Mandioli and Kasiruta, between 127° and 127° and 50' E. long. It is of an irregular form, consisting of two distinct mountainous parts, united by a low isthmus, which a slight subsidence would submerge. The area is estimated at about 600 geographical square miles. Sandstone, coralline limestone, and pebbly conglomerate are the prevailing rocks. Of volcanic formations no traces were discovered by Mr. Wallace, but other travellers speak of hot springs that seem to point to volcanic activity. The sulphur spring at Taubenkit has a temperature of 125° Fahr.; and a more remarkable example of the same phenomenon exists at Sayowang on the east coast. The highest mountain in the southern half of the island is Gunung Sabella, which is regarded by the natives as the seat of evil spirits. It was partially ascended by Bernstein in 1861. A large portion of the surface is richly wooded, and sago, cocoa-nuts, and cloves are abundantly produced, while, in spite of the extermination of nutmeg-trees by the Dutch, at least one extensive grove remains. Bachian is remarkable as the most eastern point on the globe inhabited by any of the Quadrumana. The interior of the island is uninhabited, and none of the dwellers on the coast are indigenous. They consist of the Sirani or Christian descendants of the Portuguese, of Malays, with a Papuan element, Galala men from the north of Jilolo, and a colony from Tomore, in the eastern peninsula of Celebes. The Sirani preserve various marks of their Portuguese origin, wear a semi-European dress, and celebrate Sunday with dancing and music. The government of the island is vested in a sultan, under the protection of the Dutch, to whom it is becoming of considerable importance from the discovery of coal and other minerals. The chief town or village, called Amassing by the natives, but often spoken of as Bachian, is situated on the isthmus.

**BACKGAMMON**, a game played with dice, said to have been invented about the 10th century (Strutt). The etymology of the word backgammon is disputed; it is probably Saxon,—*Bæc*, back; *gamen*, game, i.e., a game in which

the players are liable to be sent back. Other derivations are, Dan. *bakke*, tray, *gammen*, game (Wedgwood); and Welsh, *bach*, little, *cammaun*, battle (Henry).

Backgammon is played by two persons, having between them a *backgammon board*. (See diagram.) The board is divided into *tables*, each table being marked with six *points*, coloured alternately white and black. The inner and outer tables are separated from each other by a projecting bar.

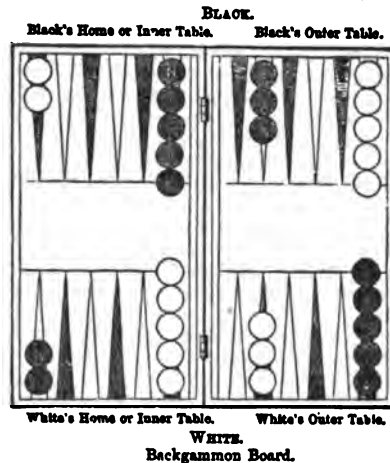

The board is furnished with fifteen white and fifteen black men, disposed at the commencement of a game in the manner shown above. The arrangement of the men may be reversed, as it would be if the diagram were turned upside down, and the white men put where the black now stand, and *vice versa*, there being no rule as to whether the play shall be from right to left, or from left to right. It is usual to make the inner table (see diagram) the one nearest to the light (*Académie des jeux; règles du jeu de toute-table*).

Two *dice boxes* are required, one for each player, and a pair of dice, which are used by both players. The dice are marked with numbers on each face from one to six, number one being called *ace*; two, *deuce*; three, *trois* (pronounced *trej*); four, *quatre* (*katre*); five, *cinque*; and six, *six* (*sise*).

The board being arranged, each player throws one die; the one who throws the higher number has the right of playing first; and he may either adopt the throw originally made by the two players, each throwing one die; or he may throw again, using both dice.

Each player moves his own men from point to point, the moves being determined by throws of the dice made by the players alternately. A player may move any of his men a number of points corresponding to the numbers thrown by him, provided the board is not *blocked* by two or more of his adversary's men occupying the point to which he wishes to move. Thus, suppose white throws cinque, six, he may move one of his men from the left-hand corner of the black's inner table to the left-hand corner of black's outer table for six; he may, again, move the same man five points further on, viz., to the right-hand point of the same table for five, when his move is completed; or he may leave the man first moved six, and move any other man five points, where the board is open. But white cannot move a man for five from the ace point in black's inner table, because the six point in that table (i.e., the fifth point from where white moves) is blocked by the black men. Any part of the throw which cannot be moved is of no effect; but it is compulsory for a player to move the whole throw if he can. Thus, if the men were differently placed, and white could move a six, and having

do so could not move a five, his move is completed. If, however, by moving the five first, he can afterwards move a six, he may be required to make the move in that manner. All white's moves must be in the direction indicated, viz., from black's inner table to black's outer, and from this to white's outer table, and so on to white's inner table; and all black's moves must be in the contrary direction. Of course, where men are originally placed part of the way home, they only have to traverse the remainder of the distance.

A player in moving must not skip a point which is blocked by his adversary's men. Thus, suppose white's first throw is five, he cannot move a man from the ace point of black's inner table to the cinque point of black's outer, although that is free; because in moving the first cinque he comes to a point which is occupied by black.

When two similar numbers are thrown (called *doublets*), the player has a double move. Thus, if he throws aces he has to move four aces instead of two, and so on for the other numbers.

When a player moves his men so as to occupy a point with two men, it is called *making a point*. Thus, if ace, trois are thrown and white moves one man from the three in his outer table to the cinque point in his inner table, for trois, and then moves a man from the six point to the cinque point of his inner table, for ace, he makes a point there.

If a player leaves only a single man on a point, or places a single man on an unoccupied point, it is called *leaving a blot*. Thus, if the first throw is six, cinque, and white carries a man from black's inner table as far as he will go, white leaves a blot on the ace point of his opponent's home table.

When a blot is left the man may be taken up, or the blot may be *hit*, if, while it remains, the adversary throws a number which will enable him to place a man on that point. For example, if a blot is left on black's ace point, as in the case previously supposed, and black throws a five, or numbers that make up five, he can hit the blot from his six point; or similarly, if he throws seven, or numbers that make up seven, he can hit the blot from the three man posted in his outer table. The man hit is placed on the bar, and has to *enter* black's inner table again at white's next throw.

It will be observed that black in taking up white leaves a blot himself, which subjects him to be taken up if white enters with an ace. If this should occur, black's man is placed on the bar, and has at his next throw to enter white's inner table, whence he has to start his journey home. Suppose white to have a blot as before on black's ace point, and black to throw sixes, black could then move two men from white's outer table to his own bar point (so called because it is close to the bar), and thence again to his own ace point, when he would hit white without leaving a blot.

The point in which a man is entered must not be blocked by two or more men belonging to the adversary. Thus, to carry on the illustration, if white now throws aces, or sixes, or six, ace, he cannot enter at all. He is not allowed to move any man while he has one to enter; consequently his throw is null and void, and black throws again. It sometimes happens that one player has a man up, and that his adversary occupies all the points on his own home table with two or more men (called having his table *made up*). In this case, the player with a man up cannot enter; and as it is useless for him to throw, his adversary continues throwing until he is obliged to open a point on his inner table.

Two blots may be taken up at once if the adversary throws numbers that will hit them both. It is possible with doublets to take up four blots at once, but this could scarcely happen in a game between players of any proficiency.

The game proceeds by moving the men round towards home, or by hitting blots and sending them back, until one of the players gets all his men into his inner table or home. As soon as this stage is reached, the player who has accomplished it begins to take his men off the board or to bear them. Thus, suppose he has several men on every point of his table, and throws six, quatre; he bears one man from his six point, and one from his quatre point. If his six point is unoccupied, he can bear a six from his cinque point, or from the highest point which is occupied, and so on with smaller numbers, provided the numbers thrown are higher than the points occupied; if lower, the throw must be moved. A player has the option of moving a man when he can, instead of bearing it. Thus, in the case originally given the six must be borne, because a six cannot be moved; but the quatre may be moved if preferred, by moving a man from the six point to the deuce point, or from cinque point to the ace point. Doublets entitle to bear or move four men in accordance with the previous rules. The adversary similarly bears his men as soon as he gets them all home. If, after a player has commenced bearing his men, he should be hit on a blot, he must enter on his adversary's inner table, and must bring the man taken up into his own inner table before he can bear any more.

Whoever first bears all his men wins the game:—a single game or *set* if his adversary has borne any of his men; a double game or *gammon* if the adversary has not borne a man; and a triple game or *backgammon*, if, at the time the winner bears his last man, his adversary, not having borne a man, has one in the winner's inner table.

When a series of games is played, the winner of a hit has the first throw in the succeeding game; but if a gammon is won, the players each throw a single die to determine the first move of the next game.

In order to play backgammon well, it is necessary to know all the chances on two dice, and to apply them in various ways. The number of different throws that can be made is thirty-six. (See HAZARD.) By taking all the combinations of these throws which include given numbers, it is easily discovered where blots may be left with the least probability of being hit. For example, to find the chance of being hit where a blot can only be taken up by an ace; the adversary may throw two aces, or ace in combination with any other number up to six, and he may throw each of these in two different ways, so that there are in all eleven ways in which an ace may be thrown. This deducted from thirty-six (the total number of throws), leaves twenty-five; so that it is 25 to 11 against being hit on an ace. It is very important to bear in mind the chance of being hit on any number. The following table gives the odds against being hit on any number within the reach of one or two dice:—

It is 25 to 11, or about 9 to 4, against being hit on 1	It is 25 to 11, or about 9 to 4, against being hit on 1
" 24 " 12, or 2 " 1, "	" 23 " 14, or about 5 " 2, "
" 21 " 15, or 7 " 5, "	" 21 " 15, " 7 " 5, "
" 19 " 17, " 9 1/2 " 5 1/2, "	" 19 " 17, " 9 1/2 " 5 1/2, "
" 20 " 6, " 5 " 1, "	" 20 " 6, " 5 " 1, "
" 20 " 6, " 5 " 1, "	" 21 " 5, " 6 " 1, "
" 21 " 5, " 6 " 1, "	" 22 " 5, " 6 " 1, "
" 24 " 2, " 17 " 1, "	" 24 " 2, " 17 " 1, "
" 35 " 1, " 35 " 1, "	" 35 " 1, " 35 " 1, "

The table shows that if a blot must be left within the reach of one die (i.e., on any number from 1 to 6), the nearer it is left to the adversary's man, the less probability there is of its being hit. Also, that it is long odds against being hit on a blot which is only to be reached with double dice, and that, in that case (i.e., on any number from 7 to 12), the further off the blot is, the less chance there is of its being hit.

The table assumes that the board is open for every possible throw. If part of the throw is blocked by an intervening point being held by adverse men, the chance of being hit may be less. Thus, a blot may be hit on an eight with duces; fours; cinque, trois (twice); or six, deuce (twice). If the fourth point is blocked, the blot cannot be hit with duces or fours, and consequently the chance of its being hit is reduced from 30 to 6 to 32 to 4, or from 5 to 1 to 8 to 1.

Two principles, then, have to be considered in moving the man:—(1.) To make points where there is the best chance of obstructing the opponent; (2.) When obliged to leave blots, to choose the position in which they are least likely to be hit, *i.e.*, either as near as possible to an adverse man, or as far as possible from any adverse men; or where the intervening points are blocked by the player's own men.

At the beginning of the game it is advisable, if possible, to secure the cinque point in your own inner table, or the cinque point in your adversary's inner table, or both. If you succeed in this, you should then play a bold game in hopes of winning a gammon. The next best point to gain is your own bar point; and the next to that the quatre point in your own inner table.

If you are fortunate enough to secure all these points, and your adversary's inner table is less favourably made up, it is then to your interest to open your bar point (in expectation of compelling your adversary to run out of your inner table with a six), and also to keep any men you may have in the outer tables spread (*i.e.*, not to crowd a number of men on one point). In this case you have a good chance of hitting the man your adversary brings out, and also of hitting the man he has left on your ace point.

If you succeed in taking both these men, and your adversary has a blot in his inner table, it will be to your interest not to make up your own table, but to leave a blot there on purpose, in hopes of his entering on it. You will then have a probability of hitting a third man, which, if accomplished, will give you considerable odd: (according to Hoyle, 4 to 1) in favour of winning a gammon; whereas if you have only two of his men up, the odds are against your gammoning him.

The best move for every possible throw at the commencement of a game is as follows:—If you throw ace (the best of all throws), move two on your bar point and two on your cinque point. This throw is often given to inferior players by way of odds.

**Ace deuce:** move the ace from your adversary's ace point (if playing for a hit only), and the deuce from the five men placed in your adversary's outer table. If playing for a gammon, move the ace from the six to the cinque point in your inner table.

**Ace trois:** make the cinque point in your inner table.

**Ace quatre and ace cinque:** move the ace from your adversary's ace point, and the quatre or cinque from the five men in your adversary's outer table. If playing for a gammon, play the ace on the cinque point in your inner table.

**Ace six:** make your bar point.

**Duces:** move two on the quatre point in your inner table, and two on the trois point in your opponent's inner table. If playing for a gammon, move two on the quatre point in your inner table, and two from the five men in your adversary's outer table.

**Duces trois and deuce cinque:** move two men from the five placed in your adversary's outer table.

**Duces quatre:** make the quatre point in your own table.

**Duces six:** move a man from the five in your adversary's outer table, and place him on the cinque point in your own table.

**Threes:** play two on the cinque point in your inner table, and three on the quatre point of your adversary's inner table. For a gammon, play two on your cinque point and two on your trois point in your inner table.

**Trois quatre:** move two men from the five in your opponent's outer table.

**Trois cinque:** make the trois point in your own table.

**Trois six:** bring a man from your adversary's ace point as far as he will go.

**Fours:** move two on the cinque point in your adversary's inner table, and two from the five in his outer table. For a gammon, move two men from the five in your opponent's outer table to the cinque point in your own table.

**Quatre cinque and quatre six:** carry a man from your adversary's ace point as far as he will go.

**Fives:** move two men from the five in your adversary's outer table to the trois point in your inner table.

**Cinque six:** move a man from your adversary's ace point as far as he will go.

**Sixes (the second best throw):** move two on your adversary's bar point, and two on your own bar point.

Subsequent moves depend on the intervening throws; consequently the problem becomes too complicated for analysis. Some general rules, however, may be given.

In carrying the men home carry the most distant man to your adversary's bar point, next to the six point in your outer table, and then to the six point in your inner table. By following this rule as nearly as the throws admit, you will carry the men to your inner table in the fewest number of throws. When all are home but two, it is often advisable to lose a point, if by so doing you put it in the power of a high throw to save a gammon.

If, in endeavouring to gain your own or your adversary's cinque point, you have to leave a blot and are hit, and your adversary is forwarder in the game than you, you must put another man on your cinque or bar point, or into your adversary's table. If this man is not hit, you may then make a point, and so get as good a game as your opponent. If it is hit, you must play a *best* game (*i.e.*, allow him to take up as many men as he likes); and then in entering the men taken up, endeavour to secure your adversary's ace and trois points, or ace and deuce points, and keep three men upon his ace point, so that if you hit him from there you still keep the ace point protected.

To find which is the forwarder, reckon how many points you have to bring all your men home to the six point in your inner table. Add to this six for every man on the six point in your tables, five for every man on your cinque point, and so on; and then make the same calculation for your adversary's men.

Avoid carrying many men upon the trois or deuce point in your own tables, as these men are out of play, and the board is left open for your adversary.

Whenever you have taken up two of your adversary's men, and have two or more points made in your inner table, spread your other men to take the best chance of making another point in your tables, and of hitting the man your adversary enters. As soon as he enters, compare his game with yours, and, if equal or better, take up his man, except when playing for a hit only, and your playing the throw gives you a better chance for the hit.

Always take up a man if the blot you leave in making the move can only be hit with double dice, except when playing for a hit only, and you already have two of your opponent's men in your tables, and your game is forwarder; because your having three of his men in your tables gives him a better chance of hitting you without leaving a blot than if he has only two.

In entering a man which it is to your adversary's advantage to hit, leave the blot upon the lowest point you can, *e.g.*, ace point in preference to deuce point, and so on; because this crowds his game by taking out of it the men played on the low point.

When your adversary is bearing his men, and you have two men in his table, say on his ace point, and several men in the outer table, it is to your advantage to leave one man on the ace point, because it prevents his bearing his men to the greatest advantage, and gives you the chance of his leaving a blot. But if, on calculation, you find that you can probably save the gammon by bringing both your men out of his table, do not wait for a blot. To make this calculation, you must ascertain in how many throws you can bring all your men home (a throw averaging eight points), and in how many throws he can bear all his men, on the assumption that he will bear on the average two men at each throw.

The laws of backgammon (as given by Hoyle), are as follows:—

1. When a man is taken from any point, it must be played; when two men are taken from it, they also must be played.
2. A man is not supposed to be played till it is placed upon a point and quitted.
3. If a player have only fourteen men in play, there is no penalty inflicted, because by his playing with a lesser number than he is entitled to, he plays to a disadvantage for want of the deficient man to make up his tables.
4. If he bear any number of men before he has entered a man taken up, and which of course he was obliged to enter, such men so borne must be entered again in the adversary's tables as well as the man taken up.
5. If he have mistaken his throw and played it, and his adversary have thrown, it is not in the choice of either of the players to alter it, unless they both agree so to do.

*Russian Backgammon* or *Tri-Tabac* is played with the same implements as backgammon. The men are not placed on the board, but both black and white are entered in the same table by throws of the dice, and both players move

in the same direction round to the opposite table. A player is not obliged to enter all his men before he moves any; and he can take up blots on entering, although he has some of his men, which have never been entered, off the board. But, while a player has a man up, he must enter it before entering any more, or moving any of those already entered. If he cannot enter the man that is up he loses the benefit of the throw.

A player who throws doublets must move not only the number thrown, but also doublets of the number corresponding to the opposite side of the dice; thus, if he throws sixes, he must first enter or move the sixes, as the case may be, and then aces, and he also has another throw. If he throws doublets a second time, he moves according to the rule already given, and throws again, and so on. The privilege is sometimes restricted by not allowing this advantage to the first doublets thrown by each player. It is sometimes extended by allowing the thrower of deuce, ace, to choose any doublets he likes on the opposite sides of the dice, and to throw again. The restriction with regard to the first doublets thrown does not apply to deuce, ace, nor does throwing it remove the restriction with regard to first doublets.

A player must first be able to complete the doublets

thrown. If he cannot move the whole throw, he cannot take the corresponding doublets; and he is not allowed another throw if he cannot move all the points to which he is entitled. In other respects the game is similar to ordinary backgammon. The chief object in the game is for the player who has his men in advance to secure as many successive points as possible, so that his adversary may be unable to pass or hit the forward men. (H. J.)

BACKHUYSEN, LUDOLF, an eminent painter of the Dutch school, was born at Embden, in Hanover, in 1631, and died in 1709. He was brought up as a merchant at Amsterdam, but early discovered so strong a genius for painting that he relinquished business and devoted himself to art. He studied first under Everdingen and then under Dubbels, two eminent masters of the time, and soon became celebrated for his sea pieces. He was an ardent student of nature, and frequently exposed himself on the sea in an open boat in order to study the effects of tempests. His compositions, which are very numerous, are nearly all variations of one subject, and in a style peculiarly his own, marked by intense realism or faithful imitation of nature. In his later years Backhuysen employed his time in etching and calligraphy. Several of his best pieces are in the gallery of the Louvre.

## BACON, FRANCIS

**B**ACON, FRANCIS, BARON VERULAM, VISCOUNT ST ALBAN, was born at York House in the Strand, London, on the 22d January 1561. He was the youngest son of Sir Nicholas Bacon, the celebrated lawyer and statesman, who for twenty years of Elizabeth's reign held the seals as lord keeper. His mother, the second wife of Sir Nicholas, was a daughter of Sir Anthony Cooke, formerly tutor to Edward VI. She was a woman of considerable culture, well skilled in the classical studies of the period, and a warm adherent of the Reformed or Puritan Church. One of her sisters was married to the famous Lord Treasurer Burghley. Very little is known of Bacon's early life and education. His health being then, as always, extremely delicate, he probably received much of his instruction at home. Yet, Rawley tells us, "his first and childish years were not without some mark of eminency; at which time he was endued with that pregnancy and towardness of wit, as they were presages of that deep and universal apprehension which was manifest in him afterwards, and caused him to be taken notice of by several persons of worth and place, and especially by the queen, who, as I have been informed, delighted much to confer with him and to prove him with questions; unto whom he delivered himself with that gravity and maturity above his years that her majesty would often term him, *The young lord keeper*." In April 1573 he was entered at Trinity College, Cambridge, where for three years he resided with his brother Anthony. Our information with regard to these important years is singularly scanty. We know only that Bacon at Cambridge, like Descartes at La Flèche, applied himself diligently to the several sciences as then taught, and came to the conclusion that the methods employed and the results attained were alike worthless and erroneous. Although he preserved a reverence for Aristotle (of whom, however, he seems to have known but little), he learned to despise the Aristotelian philosophy. It yielded no fruit, was servicable only for disputation, and the end it proposed to itself was a mistaken one. Philosophy must be taught its true business, and to attain its new aim a new method must be devised. With the first germs of this great conception in his mind, Bacon left the university in 1576.

In the same year he and his brother Anthony were

entered *de societate magistrorum* at Gray's Inn, and a few months later he was sent abroad with Sir Amyas Paulet, the English ambassador at Paris. He spent some time in that city, and travelled through several of the French provinces. The disturbed state of government and society in France at that time must have afforded him much valuable political instruction; and it has been commonly supposed that certain *Notes on the State of Christendom*, usually printed in his works, contain the results of his observations. But Mr Spedding has shown that there is no reason for ascribing these "Notes" to him, and that they may be attributed with more probability to one of his brother Anthony's correspondents.

The sudden death of his father in February 1579 necessitated Bacon's return to England, and exercised a very serious influence on his fortunes. A considerable sum of money had been laid up by Sir Nicholas in order to purchase an estate for his youngest son, the only one otherwise unprovided for. Owing to his sudden death, this intention was not carried out, and but a fifth part of the money descended to Francis, who thus began his career in comparative poverty. It was one of the gravest misfortunes of his life: he started with insufficient means, acquired a habit of borrowing, and was never afterwards out of debt. As it had become absolutely necessary that he should adopt some profession by which an adequate income would be yielded, he selected that of law, and took up his residence at Gray's Inn in 1579.

Nothing throws so clear a light on the career of any great man as a knowledge of his character and aims when he made the first step into the world. We learn from this how he himself desired to shape his course, and at every point can see how far his actions correspond to the end he had placed before him. We have, fortunately, information from Bacon himself on these points. In the fragment *De Interpretatione Naturæ Proœmium* (written probably about 1603) he analyzes his own mental character, and lays before us the objects he had in view when he entered on public life. If his opening sentence, *Ego cum me ad utilitates humanas natum existimarem*, seems at first sight a little arrogant, it must be remembered that it is the arrogance of the *μεγαλόψυχος*, who thinks himself worthy

of great things, and is worthy; it is a great self-esteem, based upon a consciousness of great powers. This grand and comprehensive aim, the production of good to the human race through the discovery of truth, was combined in him with the more practical desire to be of service to his country, service for which he felt himself by birth and education eminently fitted. He purposed, therefore, to obtain, if possible, some honourable post in the state which would give him the means of realising, so far as in him lay, these two great projects, and would at the same time enable him to do somewhat for the church, the third of the objects whose good he had at heart. The constant striving after these three ends is the key to Bacon's life. His qualifications for accomplishing the task he thus set before him were not small. His intellect was far-seeing and acute, quick and yet cautious, meditative, methodical, and free from prejudice. If we add to this account what Bacon himself does not tell us—that he seems to have been of an unusually sweet temper and amiable disposition—we shall have a fairly complete picture of his mental character at the critical period of his entry into the world.

In 1580 he appears to have taken the first step in his projected career by applying, through his uncle, Burghley, for some post at court. His suit, though well received by the queen and the lord treasurer, was unsuccessful; the particulars of it are totally unknown. For two years after this disappointment he worked quietly at Gray's Inn, and in 1582 was admitted an outer barrister. In 1584 he took his seat in Parliament for Melcombe in Dorsetshire, but the notes for the session do not disclose what part he took or what reputation he gained. About the same time he made another application to Burghley, apparently with a view to expediting his progress at the bar. His uncle, who appears to have "taken his zeal for ambition," wrote him a severe letter, taking him to task for arrogance and pride, qualities which Bacon vehemently disclaimed. It is uncertain what success attended this suit; but as his advancement at the bar was unusually rapid, his uncle's influence may not improbably have been exerted in his behalf. Some years later, in 1589, he received the first substantial piece of patronage from his powerful kinsman, the reversion of the clerkship of the Star Chamber being granted to him. The office was valuable, worth about £1600 a year; but it did not become vacant for nearly twenty years, and was thus, as Bacon used to say, "like another man's ground but tailing upon his house, which might mend his prospect, but did not fill his barn." A considerable period of his life had thus slipped away, and his affairs had not prospered. He had written on the condition of parties in the church; he had set down his thoughts on philosophical reform in the lost tract, *Temporis Partes Maxime*; but he had failed in obtaining the position which he looked upon as an indispensable condition of success. A long and eloquent letter to Burghley,<sup>1</sup> written

<sup>1</sup> "I was how somewhat ancient; one-and-thirty years is a great deal of sand in the hour-glass. . . . I ever bare a mind (in some middle piece that I could discharge) to serve her majesty; not as a man born under Sol, that loveth honour; nor under Jupiter, that loveth business (for the contemplative planet carrieth me away wholly); but as a man born under an excellent sovereign, that deserveth the dedication of all men's abilities. . . . Again, the meanness of my estate doth somewhat move me; for though I cannot accuse myself that I am either prodigal or slothful, yet my health is not to spend, nor my course to get. Lastly, I confess that I have as vast contemplative ends as I have moderate civil ends: for I have taken all knowledge to be my province; and if I could purge it of two sorts of revens, whereof the one with frivolous disputations, confutations, and verbosities, the other with blind experiments and artificial traditions and impostures, hath committed so many spoils, I hope I should bring in industrious observations, grounded conclusions, and profitable inventions and discoveries—the best state of that province. This, whether it be curiosity, or vain-glory, or nature, or (if one take it favourably) *philanthropia*, is so fixed in my mind as it cannot be

under these circumstances, gives a vivid picture of his mental state, throws additional light upon his character and aims, and at the same time gives a slight hint as to the cause of his uncle's slackness in promoting him.

Some time before this, perhaps as early as 1588, Bacon appears to have become acquainted with Essex, the impetuous and headstrong favourite of Elizabeth's later years. At the close of 1591 he was acting as the earl's confidential adviser, and in the following year Anthony Bacon, returning from the Continent, was also introduced to the young nobleman, and the two brothers exerted themselves diligently in his service. In Feb. 1593 Parliament was called, and Bacon took his seat as member for Middlesex. The special occasion for which the House had been summoned was the discovery of one of the numerous Popish plots that distracted Elizabeth's reign. The conspiracy seemed to be formidable, and Government felt the necessity for increased supplies. As Bacon's conduct in this emergency seriously affected his fortunes, and has been much misunderstood, it is necessary to state, as briefly as possible, the whole facts of the case. The House having been duly informed of the state necessities, assented to a double subsidy, and appointed a committee to draw up the requisite articles. Before this was completed, a message arrived from the House of Lords requesting a conference, which was granted. The committee of the Commons were then informed that the crisis demanded a triple subsidy to be collected in a shorter time than usual, that the Lords could not assent to less than this, and that they desired to confer on the matter. This proposal of the Lords to discuss a supply infringed upon the privileges of the Commons; accordingly, when the report of committee was read to the lower House, Bacon stood up and spoke against the proposed conference, pointing out at the same time that a communication from the Lords might be received, but that the actual deliberation on it must be taken by themselves alone. His motion, after some delay, was carried, and the conference was rejected. The Lords upon this lowered their demands, and desired merely to make a communication, which, being legitimate, was at once assented to. The House had then before them the proposal for a triple subsidy, to be collected in three, or, as the motion ultimately was shaped, in four years, instead of in six, as the ordinary custom would have been. Bacon, who approved of the increased subsidy, was opposed to the short period in which it was proposed to be raised. He suggested that it would be difficult or impossible for the people to meet such heavy demands, that discontent and trouble would arise, and that the better method of procedure was to raise money by levy or imposition. His motion appears to have received no support, and the four years' subsidy was passed unanimously. Bacon, as it turned out, had been mistaken in thinking that the country would be unable to meet the increased taxation, and his conduct, though prompted by a pure desire to be of service to the queen, gave deep and well-nigh ineradicable offence. He was accused of seeking popularity, and was for a time excluded from the court. His letter to Burghley,<sup>2</sup> who had told him of the queen's displeasure with his speech, offers no apology for what he had

removed. And I do easily see, that piece of any reasonable commandment doth bring commandment of more vits than of a man's own. . . . And if your lordship shall find now, or at any time, that I do seek or affect any place whereunto any that is nearer to your lordship shall be convenient, say then that I am a most dishonest man. And if your lordship will not carry me on, . . . this I will do, I will sell the inheritance that I have, and purchase some lease of quick revenue, or some office of gain that shall be executed by deputy, and so give over all care of service, and become some sorry bookmaker, or a true pioneer in that mine of truth."—(Spedding, *Letters and Life*, i. 108-9.)

<sup>2</sup> Spedding, *Letters and Life*, i. 234-35, cf. i. 363. This letter, with those to Puckering or Essex and the queen, i. 240-41, should be compared with what is said of them by Macaulay in his *Essay on Bacon*, and by Campbell, *Lives*, ii. 287.

said, but expresses regret that his motives should have been misunderstood, and that any offence should have been taken. He soon felt that the queen's anger was not to be appeased by such a justification. The attorney-generalship had fallen vacant, and Bacon became a candidate for the office, his most formidable rival being his life-long antagonist, Coke, who was then solicitor. Essex warmly espoused Bacon's cause, and earnestly pressed his claims upon the queen; but his impetuous, pettish pleading tended rather to retard than advance the cause. Burghley, on the other hand, in no way promoted his nephew's interest; he would recommend him for the solicitorship, but not for the attorney-generalship; and it is not improbable that Sir Robert Cecil secretly used his influence against his cousin. The queen delayed the appointment, and Bacon's fortunes, as they then stood, could ill brook delay. He was harassed with debt, and at times so disheartened that he contemplated retirement from public life and devotion to abstract studies. In March 1594 it was at last understood that Coke was to be attorney-general. Essex, though bitterly mortified, at once threw all his energies into the endeavour to procure for Bacon the solicitorship; but in this case also, his method of dealing, which was wholly opposed to Bacon's advice,<sup>1</sup> seemed to irritate, instead of conciliating the queen. The old offence was not yet forgiven, and after a tedious delay, the office was given, in Oct. 1595, to Sergeant Fleming. Burghley and Puckering seem to have assisted Bacon honestly, if not over-warmly, in this second application; but the conduct of Cecil had roused suspicions which were not perhaps without foundation. Essex, to compensate in some degree for Bacon's disappointment, insisted upon presenting him with a piece of land, worth about £1800, and situated probably near Twickenham Park. Nor did his kindness cease there; before sailing on the expedition to Cadix, in the beginning of 1596, he addressed letters to Buckhurst, Fortescue, and Egerton, earnestly requesting them to use their influence towards procuring for Bacon the vacant office of master of the rolls. Before anything came of this application, the Cadix expedition had resulted in a brilliant success, and Essex became the idol of the army and the people. Bacon saw clearly that such a reputation would assuredly alienate the affections of the queen, who loved not to have a subject too powerful or too popular. He therefore addressed an eloquent and imploring letter to the earl, pointing out the dangers of his position, and urging upon him what he judged to be the only safe course of action, to seek and secure the favour of the queen alone; above all things dissuading him from the appearance of military popularity. His advice, however, was unpalatable and proved ineffectual. The earl still continued his usual course of dealing with the queen, depending solely upon her supposed affection for him, and insanely jealous of any other whom she might seem to favour. His unskilful and unlucky management of the sea expedition to Ferrol and the Azores in no way lowered his popularity with the people, but undoubtedly weakened his influence with the queen.

Bacon's affairs in the meantime had not been prospering. He had increased his reputation by the publication, in 1597, of his *Essays*, along with which were the *Colours of Good and Evil* and the *Meditationes Sacre*; but his private fortunes were in a bad condition. No public office apparently could be found for him; he failed in the endeavour to retrieve his position by a marriage with the wealthy widow, Lady Hatton, and in 1598 he was arrested for debt. He seems, however, to have been growing in favour with the queen. Some years previously (perhaps about 1594), he had begun to be employed by her in crown affairs, and he gradually acquired the standing of one of the learned

counsel, though he held no commission or warrant, and received no salary. At the same time he was no longer on the former friendly terms with Essex, a certain estrangement having sprung up between them, caused no doubt by the earl finding his friend's advice distasteful. The earl's affairs were then at a somewhat critical stage, and as our judgment upon a most important episode in Bacon's life depends upon our knowledge of the events of the ensuing year, it will be requisite to enter more minutely than would otherwise be necessary into proceedings with which Bacon himself had nothing to do.

Ireland was then in a rebellious and discontented condition, and it was somewhat difficult for the English Government to decide either on a definite course of policy with regard to it, or on a leader by whom that policy might be carried out. Upon this subject a violent quarrel took place between the queen and Essex, who for some months retired from court, and refused to be reconciled. At last he came forth from his seclusion, and it was soon understood that he was in person to undertake the subjugation of the rebels in Ireland, with a larger force than had ever before been sent into that country. Into the obscure details of this unhappy campaign it is unnecessary to enter; one fact stands out clearly, that Essex endeavoured to carry out a treasonable design. His jealousy and ill temper had been so roused that the only course open to him seemed to be the obtaining a powerful military force, the possession of which would compel the queen to reinstate him in her favour. Whether or not this plan was in contemplation before he undertook the Irish expedition is not evident, though even outsiders at that time entertained some suspicions, but there can be no doubt of the treasonable character of the negotiations carried on in Ireland. His plans, probably not very definite, were disturbed by an imperative message from the queen, ordering him not to return to England without her permission. He at once set off, and, trusting apparently to her affection for him, presented himself suddenly before her. He was, for the moment, received kindly, but was soon afterwards ordered to keep his chamber, and was then given into the custody of the lord keeper at York House, where he remained till March 1600. His great popularity, and the general ignorance of the reasons for his imprisonment, stirred up a strong feeling against the queen, who was reported to be influenced by Bacon, and such indignation was raised against the latter, that his friends feared his life would be in danger. The groundless character of this accusation shows how little confidence should be reposed in popular versions of obscure occurrences. It was at last felt necessary that the queen should in some way vindicate her proceedings, and this she at first did, contrary to Bacon's advice, by a declaration from the Star Chamber. This, however, gave little or no satisfaction, and it was found expedient to do what Bacon had always recommended, to have a fair trial, yet not one in which the sentence must needs be damaging to the earl. The trial accordingly took place before a body of her majesty's councillors, and Bacon had a subordinate and unimportant part in the accusation. Essex does not seem to have been at all hurt by his action in this matter, and shortly after his release they were again on friendly terms, Bacon drawing up letters as if to or from the earl with the design of having them brought before the queen. But Bacon did not know the true character of the transactions in which Essex had been engaged. The latter had been released from all custody in August, but in the meantime he had been busily engaged in treasonable correspondence with James of Scotland, and was counting on the Irish army under his ally, Montjoy, the new deputy. But Montjoy had apparently come to see how useless the attempt would be to force upon the queen a settlement of the succession, and declined to go further in the matter.

<sup>1</sup> See *Letters and Life*, i. 289, ii. 34.

Essex was thus thrown upon his own resources, and his anger against the queen being roused afresh by the refusal to renew his monopoly of sweet wines, he formed the desperate project of seizing her person and compelling her to dismiss from her council his enemies Raleigh, Cobham, and Cecil. As some pretext, he intended to affirm that his life was in danger from these men, who were in league with the Spaniards. The plot was forced on prematurely by the suspicions excited at court, and the rash attempt to rouse the city of London (8th February 1601) proved a complete fiasco. The leaders were arrested that night and thrown into prison. Although the actual rising might have appeared a mere outburst of frantic passion, the private examinations of the most prominent conspirators disclosed to the Government a plot so widely spread, and involving so many of the highest in the land, that it would have been perilous to have pressed home accusations against all who might be implicated. Essex was tried along with the young earl of Southampton, and Bacon, as one of her majesty's counsel, was present on the occasion. Coke, who was principal spokesman, managed the case with great want of skill, incessantly allowing the thread of the evidence to escape, and giving the prisoners opportunity to indulge in irrelevant justifications and protestations which were not ineffectual in distracting attention from the real question at issue. On the first opportunity Bacon rose and briefly pointed out that the earl's plea of having done nothing save what was absolutely necessary to defend his life from the machinations of his enemies was weak and worthless, inasmuch as these enemies were purely imaginary; and he compared his case to that of Pisisstratus, who had made use of a somewhat similar stratagem to cloak his real designs upon the city of Athens. He was thereupon interrupted by the earl, who proceeded to defend himself, by declaring that in one of the letters drawn up by Bacon, and purporting to be from the earl to Anthony Bacon, the existence of these rumours, and the dangers to be apprehended from them, had been admitted; and he continued, "If these reasons were then just and true, not counterfeit, how can it be that now my pretences are false and injurious?" To this Bacon replied, that "the letters, if they were there, would not blush to be seen for anything contained in them, and that he had spent more time in vain in studying how to make the earl a good servant to the queen than he had done in anything else." It seems to be forgotten in the general accounts of this matter, not only that Bacon's letters bear out what he said, but that the earl's excuses were false. A second time Bacon was compelled to interfere in the course of the trial, and to recall to the minds of those present the real question at issue. He animadverted strongly upon the puerile nature of the defence, and in answer to a remark by Essex, that if he had wished to stir up a rebellion he would have had a larger company with him, pointed out that his dependence was upon the people of London, and compared his attempt to that of the duke of Guise at Paris. To this the earl made little or no reply. Bacon's use of this illustration, and of the former one of Pisisstratus, has been much commented on, and in general it seems to have been thought that had it not been for his speeches Essex might have escaped, or, at all events, have been afterwards pardoned. But this view of the matter depends on the supposition that Essex was guilty only of a rash outbreak.<sup>1</sup> That this was not the case was well known to the queen and her council. Unfortunately, prudential motives hindered the publication of the whole evidence; the people, consequently, were still ignorant of the magnitude of the crime, and, till recently, biographers of Bacon have been in a like ignorance.<sup>2</sup> The

earl himself, before execution, confessed his guilt and the thorough justice of his sentence, while, with singular lack of magnanimity, he incriminated several against whom accusations had not been brought, among others his sister Lady Rich. After his execution it was thought necessary that some account of the facts should be drawn up and circulated, in order to remove the prejudices against the queen's action in the matter. This was intrusted to Bacon, who drew up a *Declaration of the Practices and Treasons attempted and committed by Robert, late Earl of Essex*, his first draft being extensively altered and corrected by the queen and council. Nothing is known with certainty of the reception given to this official explanation, but the ill feeling against Bacon was not wholly removed, and some years later, in 1604, he published, in the form of a letter to Montjoy, an *Apology* for his action in the case. This *Apology* gives a most fair and temperate history of the relations between Bacon and Essex, shows how the prudent counsel of the one had been rejected by the other, and brings out very clearly what we conceive to be the true explanation of the matter. Everything that Bacon could do was done by him, until the real nature of Essex's design was made apparent, and then, as he had repeatedly told the earl, his devotion and respect were for the queen and state, not for any subject; friendship could never take rank above loyalty. Those who blame Bacon must acquit Essex of all wrong-doing.

Bacon's private fortunes, during the period after the death of Essex, were not in a flourishing condition. He had obtained a grant of £1200 from the fines imposed on Catesby, one of the conspirators, but his debts were sufficient to swallow up this and much more. And, though he was trusted by Elizabeth, and on good terms with her, he seems to have seen that he had no chance of advancement. But her death in 1603, followed by the undisputed succession of James, gave him new hopes; to use his own expression, he found himself "as one awaked out of sleep." It appeared to him that at length the abilities he was conscious of possessing would obtain recognition; he thought that "the canvassing world" had gone, and the "deserving world" had come. He used every means in his power to bring himself under James's notice, writing to all his friends at the Scottish court and to the king himself. He managed to obtain a personal interview with the king, but does not seem to have been much satisfied with it. In fact, while the king confirmed in their situations those who had held crown offices under Elizabeth, Bacon, not holding his post by warrant, was practically omitted. He was, however, continued, by special order of the king, as learned counsel extraordinary, but little or no law business appears to have been intrusted to him. He procured, through his cousin Cecil, the dignity of knighthood, which, contrary to his inclination, he received along with about 300 others, on the 25d July 1603. Between this time and the opening of James's first Parliament he was engaged in literary work, and sent to the king two pamphlets—one on the Union, the other on measures for the pacification of the church. What opinion was formed of them by James is unknown. Shortly after he published his *Apology*; the reception it met with is equally uncertain. In March 1604 Parliament met, and during their short session Bacon's hands seem to have been full of work. It was a busy and stirring time, and events occurred during it which carried within them the seeds of much future dissension. Prerogative and privilege came more than once into collision, the abuses of purveyance and wardship were made matters of conference, though the thorough discussion of them was deferred to a

<sup>1</sup> See Macaulay's *Essex* on Bacon.

<sup>2</sup> The whole story of Essex is given in Mr Spalding's *Letters and*

*Life*. It is also very vigorously told by Mr Bruce in the Introduction to his *Correspondence of James VI. with Sir Robert Cecil*, Camden Society, 1861.

successing session; while James's temper was irritated by the objections brought against his favourite scheme of the Union, and by the attitude taken up by the House with regard to religious affairs. The records are barely full enough to enable us to judge very accurately of the share taken by Bacon in these discussions; his name generally appears as the reporter of the committees on special subjects. We can occasionally, however, discern traces of his tact and remarkable prudence; and, on the whole, his attitude, particularly with regard to the Union question, recommended him to James. He was shortly afterwards formally installed as learned counsel, receiving the salary of £40, and at the same time a pension of £60 yearly. He was also appointed one of the commission to treat of the conditions necessary for the Union; and the admirable manner in which the duties of that body were discharged must be attributed mainly to his influence and his complete mastery of the subject. During the recess he published his *Advancement of Learning*, dedicated to the king.

He was now fairly brought into relations with James, and his prospects began to look a little brighter. It is important for us to know what were his ideas upon government, upon parliaments, prerogative, and so forth, since a knowledge of this will clear up much that would seem inexplicable in his life. It seems quite evident<sup>1</sup> that Bacon, from position, early training, and, one might almost think, natural inclination, held as his ideal of government the Elizabethan system. The king was the supreme power, the centre of law and justice, and his prerogative must not be infringed. Parliament was merely a body called to consult with the king on emergencies (*circa ardua regni*) and to grant supplies. King and parliament together make up the state, but the former is first in nature and importance. The duty of a statesman was, therefore, to carry out the royal will in as prudent a manner as possible; he was the servant of the king, and stood or fell according to his pleasure. It is hard to put ourselves at this point of view, and we can with difficulty understand how such a man as Bacon held a theory which seems now so inadequate. But he was not singular in his opinions, and he was undoubtedly sincere; and it is only by keeping them constantly in mind that we can understand his after relations with the king.

In the second Parliament there was not so much scope for the exercise of his powers. The Gunpowder Plot had aroused in the Commons warmer feelings towards the king; they passed severe laws against recusants, and granted a triple subsidy. At the same time they continued the collection of the grievances concerning which they were to move. In the course of this session Bacon married Alice Barnham, "the alderman's daughter, an handsome maiden, to my liking," of whom he had written some years before to his cousin Cecil. Little or nothing is known of their married life.

The third Parliament was chiefly occupied with the commercial and legal questions rising out of the proposed Union, in particular, with the dispute as to the naturalisation of the *Poet Nati*. Bacon argued ably in favour of this measure, but the general feeling was against it. The House would only pass a bill abolishing hostile laws between the kingdoms; but the case of the *Poet Nati*, being brought before the law courts, was settled as the king wished. Bacon's services were rewarded in June 1607 by the office of solicitor; he had at last gained a step upon the ladder of advancement. His promotion, however, was not rapid; several years passed before he gained another step. Meantime, though circumstances had thrown him too much into active life, he had not forgotten his cherished project of reorganising science. A survey of

the ground had been made in the *Advancement*, and some short pieces not published at the time were probably written in the subsequent two or three years. Towards the close of 1607 he sent to his friends a small tract, entitled *Cogitata et Visa*, probably the first draft of what we have under that title. In 1609 he wrote the noble panegyric, *In felicem memoriam Elisabethæ*, and the curiously learned and ingenious work *De Sapientia Veterum*; and completed what seems to have been the *Redargutio Philosophiarum*, or treatise on the idols of the theatre.

In 1610 the famous fourth Parliament of James met. It is not possible to enter minutely into the important occurrences of this short session. Prerogative, despite Bacon's advice and efforts, clashed more than once with liberty; Salisbury's bold schemes for relieving the embarrassment caused by the reckless extravagance of the king proved abortive, and the House was dissolved in February 1611. Bacon took a considerable share in the debates, consistently upheld the prerogative, and seemed yet to possess the confidence of the Commons. The death of Salisbury, occurring soon after, opened a position in which Bacon thought his great political skill and sagacity might be made more immediately available for the king's service. How far he directly offered himself for the post of secretary is uncertain, but we know that his hopes were disappointed, the king himself undertaking the duties of the office. About the same time he made two ineffectual applications for the mastership of the wards; the first, on Salisbury's death, when it was given to Sir George Carey; the second, on the death of Carey. It is somewhat hard to understand why so little favour was shown by the king to one who had proved himself able and willing to do good service, and who, in spite of his disappointments, still continued zealously to offer advice and assistance. At last, in 1613, a fair opportunity for promotion occurred. The death of Sir Thomas Fleming made a vacancy in the chief-justicehip of the King's Bench, and Bacon, after some deliberation, proposed to the king that Coke should be removed from his place in the Court of Common Pleas and transferred to the King's Bench. He gives several reasons for this in his letter to the king, but in all probability his chief motive was that pointed out by Mr Spedding,<sup>2</sup> that in the Court of King's Bench there would be less danger of Coke coming into collision with the king on questions of prerogative, in handling which Bacon was always very circumspect and tender. The vacancy caused by Coke's promotion was then filled up by Hobart, and Bacon, finally, stepped into the place of attorney-general. The fact of this advice being offered and followed in all essentials, illustrates very clearly the close relations between the king and Bacon, who had become a confidential adviser on most occasions of difficulty. That his adherence to the royal party was already noticed and commented on appears from the significant remark of Chamberlain, who, after mentioning the recent changes among the law officials, says, "There is a strong apprehension that little good is to be expected by this change, and that Bacon may prove a dangerous instrument."

Further light is thrown upon Bacon's relations with James, and upon his political sympathies, by the letter to the king advocating the calling of a parliament,<sup>3</sup> and by the two papers of notes on which his letter was founded.<sup>4</sup> These documents, even after due weight is given to all considerations urged in their favour,<sup>5</sup> seem to confirm the view already taken of Bacon's theory of government, and at the same time show that his sympathies with the royal party tended to blind him to the true character of certain courses of action, which can only be justified by a strain-

<sup>1</sup> See *Letters and Life*, iv. 177, vi. 88, vii. 116, 117.

<sup>2</sup> *Letters and Life*, iv. 381.

<sup>3</sup> *Ibid.*, iv. 365-78.

<sup>4</sup> *Ibid.*, iv. 380.

<sup>5</sup> *Ibid.*, iv. 378-78.



lag of political ethics. The advice he offered, in all sincerity, was most prudent and sagacious, and might have been successfully carried out by a man of Bacon's tact and skill; but it was intensely one-sided, and exhibited a curious want of appreciation of what was even then beginning to be looked on as the true relation of king, parliament, and people. Unfortunately for James, he could neither adopt nor carry out Bacon's policy. The Parliament which met in April 1614 and was dissolved in June, after a stormy session, was by no means in a frame of mind suitable for the king's purposes. The House was enraged at the supposed project (then much misunderstood) of the "Undertaken;" objection was taken to Bacon being elected or serving as a member while holding office as attorney-general; and, though an exception was made in his favour, it was resolved that no attorney-general should in future be eligible for a seat in Parliament. No supply was granted, and the king's necessities were increased instead of diminished. The emergency suggested to some of the bishops the idea of a voluntary contribution, which was eagerly taken up by the noblemen and crown officials. The scheme was afterwards extended so as to take in the whole kingdom, but lost something of its voluntary character, and the means taken to raise the money, which were not what Bacon would have recommended,<sup>1</sup> were calculated to stir up discontent. The general dissatisfaction received a somewhat unguarded and intemperate expression in a letter sent to the justices of Marlborough by a gentleman of the neighbourhood, named St John, in which he denounced the attempt to raise funds in this way as contrary to law, reason, and religion, as constituting in the king personally an act of perjury, involving in the same crime those who contributed, and thereby subjecting all parties to the curses levelled by the church at such offences. St John was summoned before the Star Chamber for slander and treasonable language; and Bacon, *ex officio*, acted as public prosecutor. The sentence pronounced (a fine of £5000 and imprisonment for life) was severe, but it was not actually inflicted, and probably was not intended to be carried out, the success of the prosecution being all that was desired. St John remained a short time in prison, and was then released, after making a full apology and submission. The fine was remitted. It seems incredible that Bacon's conduct on this occasion should have been censured by his biographers. The offence was clear; the law was undoubted; no particular sympathy was excited for the culprit; the sentence was not carried out; and Bacon did only what any one in his place would naturally and necessarily have done. The nature of his office involved him in several trials for treason occurring about the same time, and one of these is of interest sufficient to repay a somewhat longer examination. Edmund Peacham, a clergyman in Somersetshire, had been committed to custody for a libel on his superior, the bishop of Bath and Wells. In searching his house for certain papers, the officers came upon some loose sheets stitched together in the form of a sermon, the contents of which were of such a nature that it was judged right to lay them before the council. As it was at first suspected that the writing of this book had been prompted by some disaffected persons, Peacham was interrogated, and after he had declined to give any information, was subjected to torture. Bacon, as one of the learned counsel, was ordered by council to take part in this examination, which was undoubtedly warranted by precedent, whatever may now be thought of it. Nothing, however, was extracted from Peacham in this way, and it was resolved to proceed against him for treason. Now, in the excited state of popular feeling at that period, the failure of Government to substantiate an accusation of treason would have been a serious matter. The king, with whom

the council agreed, seems therefore to have thought it desirable to obtain beforehand the opinions of the four chief judges as to whether the alleged offence amounted to treason. In this there was nothing unusual or illegal, and no objection would at that time have been made to it, but James introduced a certain innovation; he proposed that the opinions of the four judges should be given separately and in private. It may be reasonably inferred that his motive for this was the suspicion, or it may be the knowledge, that Coke did not consider the matter treasonable. At all events when Coke, who as a councillor already knew the facts of the case, was spoken with regarding the new proposal of the king, he at once objected to it, saying that "this particular and articular taking of opinions" was "new and dangerous," and "not according to the custom of the realm." He at last reluctantly assented, and proposed that Bacon should consult with him, while the other law officers addressed themselves to the three puisne judges. By Bacon's directions, the proposal to the three judges to give their opinions separately was made suddenly and confidently, and any scruples they might have felt were easily overcome. The first step was thus gained, and it was hoped that if "infusion" could be avoided, if the papers bearing on the case were presented to the judges quickly, and before their minds could be swayed by extraneous influence, their decision on the case would be the same as that of the king. It is clear that the extraneous influence to be feared was Coke, who, on being addressed by Bacon, again objected to giving his opinion separately, and even seemed to hope that his brother judges after they had seen the papers would withdraw their assent to giving their decisions privately. Even after the discussion of the case with Bacon, he would not give his opinion until the others had handed in theirs. What the other judges thought is not definitely known, but Bacon appears to have been unable to put in operation the plan he had devised for swaying Coke's judgment,<sup>2</sup> by putting him in some dark manner in doubt that he should be left alone; or if he did attempt this, he was unsuccessful, for Coke finally gave an opinion consistent with what he seems to have held at first, that the book was not treasonable, as it did not disable the king's title. Although the opinions of the judges were not made public, yet as we learn, not only from Bacon, but from a sentence in one of Carleton's letters,<sup>3</sup> a rumour had got about that there was doubt as to the book being treasonable. Under these circumstances, Bacon, who feared that such a report might incite other people to attempt a similar offence, proposed to the king that a second rumour should be circulated in order to destroy the impression caused by the first. "I do think it necessary," he says, "that because we live in an age in which no counsel is kept, and that it is true there is some bruit abroad that the judges of the King's Bench do doubt of the case that it should not be treason, that it be given out constantly, and yet as it were in secret, and so a fame to slide, that the doubt was only upon the publication, in that it was never published. For that (if your majesty marketh it) taketh away or at least qualifieth the danger of the example; for that will be no man's case."<sup>4</sup> Bacon's conduct in this matter has been curiously misrepresented. He has been accused of torturing the prisoner, and of tampering with the judges<sup>5</sup> by consulting them before the trial; nay, he is even represented as selecting this poor clergyman to serve for an example to terrify the disaffected, as breaking into his study and finding there a sermon never intended to be preached, which merely encouraged the people to resist tyranny.<sup>6</sup> All this lavish condemnation is wide of the mark, and rests on a complete misconception of the case. If any blame attaches

<sup>1</sup> *Letters and Life*, v. 81-83.

<sup>2</sup> *Letters and Life*, v. 101.

<sup>3</sup> *Ibid.*, v. 121, n.

<sup>4</sup> *Ibid.*, v. 124.

<sup>5</sup> *Maccubley's Essay*.

<sup>6</sup> *Campbell's Lives*, ii. 344.

to him, it must arise either from his endeavour to force Coke to a favourable decision, in which he was in all probability prompted by a feeling, not uncommon with him, that a matter of state policy was in danger of being sacrificed to some senseless legal quibble or precedent, or from his advice to the king that a rumour should be set afloat which was not strictly true. We do not imagine that in any other politician either of these actions would meet with very severe condemnation.

Bacon's share in another great trial which came on shortly afterwards, the Overbury and Somerset case, is not of such a nature as to render it necessary to enter upon that obscure and thorny subject.<sup>1</sup> It may be noted, however, that his letters about this time show that he had become acquainted with the king's new favourite, the brilliant Sir George Villiers, and that he stood high in the king's good graces. In the early part of 1616, when Ellesmere, the lord chancellor, was dangerously ill, Bacon wrote a long and careful letter to the king, proposing himself for the office, should it fall vacant, and stating as frankly as possible of what value he considered his services would be. In answer, he appears to have received a distinct promise of the reversion of the office; but, as Ellesmere recovered, the matter stood over for a time. He proposed, however, that he should be made a privy councillor, in order to give him more weight in his almost recognised position of adviser to the king, and on the 9th June 1616 he took the oaths and his seat at the council board.

Meanwhile, his great rival Coke, whose constant tendency to limit the prerogative by law and precedent had made him an object of particular dislike to James, had on two points come into open collision with the king's rights. The first case was an action of *promissio* against the Court of Chancery, evidently instigated by him, but brought at the instance of certain parties whose adversaries had obtained redress in the chancellor's court after the cause had been tried in the Court of King's Bench. With all his learning and ingenuity, Coke failed in inducing or even forcing the jury to bring in a bill against the Court of Chancery, and it seems fairly certain that on the technical point of law involved he was wrong. Although his motive was, in great measure, a feeling of personal dislike towards Ellesmere, yet it is not improbable that he was influenced by the desire to restrict in every possible way the jurisdiction of a court which was the direct exponent of the king's wishes. The other case, that of the *commendams*, was more important in itself and in the circumstances connected with it. The general question involved in a special instance was whether or not the king's prerogative included the right of granting at pleasure livings in *commendam*, i.e., to be enjoyed by one who was not the incumbent. Bacon, as attorney-general, delivered a speech, which has not been reported; but the king was informed that the arguments on the other side had not been limited to the special case, but had directly impugned the general prerogative right of granting livings. It was necessary for James, as a party interested, at once to take measures to see that the decision of the judges should not be given on the general question without due consultation. He accordingly wrote to Bacon, directing him to intimate to the judges his pleasure that they should delay judgment until after discussion of the matter with himself. Bacon communicated first with Coke, who in reply desired that similar notice should be given to the other judges. This was done by

<sup>1</sup> The mysterious crime supposed to be concealed under the obscure details of this case have cast a shadow of vague suspicion on all who were concerned in it. The minute examination of the facts by Mr Spodding (*Letters and Life*, v. 238-347) seems to show that these secret crimes exist nowhere but in the heated imaginations of romantic biographers and historians.

Bacon, though he seems to hint that in so doing he was going a little beyond his instructions. The judges took no notice of the intimation, proceeded at once to give judgment, and sent a letter in their united names to the king announcing what they had done, and declaring that it was contrary to law and to their oath for them to pay any attention to a request that their decision should be delayed. The king was indignant at this encroachment, and acting partly on the advice of Bacon, held a council on the 6th June 1616, at which the judges attended. James then entered at great length into the case, censuring the judges for the offensive form of their letter, and for not having delayed judgment upon his demand, which had been made solely because he was himself a party concerned. The judges, at the conclusion of his speech, fell on their knees, and implored pardon for the manner of their letter; but Coke attempted to justify the matter contained in it, saying that the delay required by his majesty was contrary to law. The point of law was argued by Bacon, and decided by the chancellor in favour of the king, who put the question to the judges individually, "Whether, if at any time, in a case depending before the judges, which his majesty conceived to concern him either in power or profit, and thereupon required to consult with them, and that they should stay proceedings in the meantime, they ought not to stay accordingly?" To this all gave assent except Coke, who said that "when the case should be, he would do that should be fit for a judge to do." No notice was taken by the king of this famous, though somewhat evasive, reply, but the judges were again asked what course they would take in the special case now before them. They all declared that they would not decide the matter upon general grounds affecting the prerogative, but upon special circumstances incident to the case; and with this answer they were dismissed. Bacon's conduct throughout the affair has been blamed, but apparently on wrong grounds. As attorney he was merely fulfilling his duty in obeying the command of the king; and in laying down the law on the disputed point, he was, we may be sure, speaking his own convictions. Censure might more reasonably be bestowed on him, because he deliberately advised a course of action than which nothing can be conceived better calculated to strengthen the hands of an absolute monarch.<sup>2</sup> This appeared to Bacon justifiable and right, because the prerogative would be defended and preserved intact. Coke certainly stands out in a better light, not so much for his answer, which was rather indefinite, and the force of which is much weakened by his assent to the second question of the king, but for the general spirit of resistance to encroachment exhibited by him. He was undeniably troublesome to the king, and it is no matter for wonder that James resolved to remove him from a position where he could do so much harm. On the 26th June he was called before the council to answer certain charges, one of which was his conduct in the *promissio* question. He acknowledged his error on that head, and made little defence. On the 30th he was suspended from council and bench, and ordered to employ his leisure in revising certain obnoxious opinions in his reports. He did not perform the task to the king's satisfaction, and a few months later he was dismissed from office.

Bacon's services to the king's cause had been most important; and as he had, at the same time, acquired great favour with Villiers, his prospects looked brighter than before. According to his custom, he strove earnestly to guide by his advice the conduct of the young favourite. His letters, in which he analyses the various relations in which such a man must stand, and prescribes the course of

<sup>2</sup> A somewhat similar case is that of the writ *De Rege in comitibus* brought forward by Bacon. See *Letters and Life*, v. 232-34.

action suitable for each, are valuable and deserving of attention.<sup>1</sup> Very striking, in view of future events, are the words<sup>2</sup> in which he gives him counsel as to his dealing with judges: "By no means be you persuaded to interpose yourself by word or letter in any cause depending, or like to be depending, in any court of justice, nor suffer any man to do it where you can hinder it; and by all means dissuade the king himself from it, upon the importunity of any, either for their friends or themselves. If it should prevail, it perverts justice; but if the judge be so just, and of so undaunted a courage (as he ought to be) as not to be inclined thereby, yet it always leaves a taint of suspicions and prejudices behind it." It is probable that Villiers at this time had really a sense of the duties attaching to his position,<sup>3</sup> and was willing to be guided by a man of approved wisdom. It was not long before an opportunity occurred for showing his gratitude and favour. Ellesmere resigned the chancellorship on the 5th March 1617, and on the 7th the great seal was bestowed upon Bacon, with the title of Lord Keeper. Two months later he took his seat with great pomp in the Chancery Court, and delivered a weighty and impressive opening discourse. He entered with great vigour on his new labours, and in less than a month he was able to report to Buckingham that he had cleared off all outstanding Chancery cases. He seemed now to have reached the height of his ambition; he was the first law officer in the kingdom, the accredited minister of his sovereign, and on the best terms with the king and his favourite. His course seemed perfectly prosperous and secure, when a slight storm arising opened his eyes to the frailty of the tenure by which he held his position.

Coke was in disgrace but not in despair; there seemed to be a way whereby he could reconcile himself to Buckingham, through the marriage of his daughter, who had an ample fortune, to Sir John Villiers, brother of the marquis, who was penniless or nearly so. The match was distasteful to Lady Hatton and to her daughter; a violent quarrel was the consequence, and Bacon, who thought the proposed marriage most unsuitable, took Lady Hatton's part. His reasons for disapproval he explained to the king and Buckingham, but found to his surprise that their indignation was strongly roused against him. He received from both bitter letters of reproof; it was rumoured that he would be disgraced, and Buckingham was said to have compared his present conduct to his previous unfaithfulness to Essex. Bacon, who seems to have acted from a simple desire to do the best for Buckingham's own interests, at once changed his course, advanced the match by every means in his power, and by a humble apology appeased the indignation that had been excited against him. It had been a sharp lesson, but things seemed to go on smoothly after it, and Bacon's affairs prospered. In January 1618 he received the higher title Lord Chancellor; in July of the same year he was made Baron Verulam; and in January 1621 he was created Viscount St Alban. His fame, too, had been increased by the publication in 1620 of his most celebrated work, the *Novum Organum*. He seemed at length to have made satisfactory progress towards the realisation of his cherished aims; the method essential for his Instauration was partially completed; and he had attained as high a rank in the state as he had ever contemplated. But history too clearly tells us that his

actions in that position were not calculated to promote the good of his country.

Connected with the years during which he held office is one of the weightiest charges against his character, Buckingham, notwithstanding the advice he had received from Bacon himself, was in the habit of addressing letters to him recommending the causes of suitors. In many cases these seem nothing more than letters of courtesy, and from the general tone, it might fairly be concluded that there was no intention to sway the opinion of the judge illegally, and that Bacon did not understand the letters in that sense. This view is supported by consideration of the few answers to them which are extant.<sup>4</sup> One outstanding case, however, that of Dr Steward,<sup>5</sup> casts some suspicion on all the others. The terms of Buckingham's note<sup>6</sup> concerning it might easily have aroused doubts; and we find that the further course of the action was to all appearances exactly accommodated to Dr Steward, who had been so strongly recommended. It is, of course, dangerous to form an extreme judgment on an isolated and partially understood case, of which also we have no explanation from Bacon himself, but if the interpretation given by Mr Heath be the true one, Bacon certainly suffered his first, and so far as we can see, just judgment on the case to be set aside, and the whole matter to be reopened in obedience to a request from Buckingham.

It is somewhat hard to understand Bacon's position with regard to the king during these years. He was the first officer of the crown, the most able man in the kingdom, prudent, sagacious, and devoted to the royal party. Yet his advice was followed only when it chimed in with James's own will; his influence was of a merely secondary kind; and his great practical skill was employed simply in carrying out the measures of the king in the best mode possible. We know indeed that he sympathised cordially with the home policy of the Government; he had no objection to such monopolies or patents as seemed advantageous to the country, and for this he is certainly not to be blamed.<sup>7</sup> The opinion was common at the time, and the error was merely ignorance of the true principles of political economy. But we know also that the patents were so numerous as to be oppressive, and we can scarcely avoid inferring that Bacon more readily saw the advantages to the Government than the disadvantages to the people. In November 1620, when a new parliament was summoned to meet on January following, he earnestly pressed that the most obnoxious patents, those of alehouses and inns, and the monopoly of gold and silver thread, should be given up, and wrote to Buckingham, whose brothers were interested, advising him to withdraw them from the impending storm. This prudent advice was unfortunately rejected. But while he went cordially with the king in domestic affairs, he was not quite in harmony with him on questions of foreign policy. Not only was he personally in favour of a war with Spain for the recovery of the Palatinate, but he foresaw in such a course of action the means of drawing together more closely the king and his Parliament. He believed that the royal difficulties would be removed if a policy were adopted with which the people could heartily sympathise, and if the king placed himself at the head of his Parliament and led them on. But his advice was neglected by the vacillating and peace-loving monarch, his proffered proclamation was put

<sup>1</sup> *Letters and Life*, vi. 6, 7, 13-25, 27-56.  
<sup>2</sup> *Ibid.*, vi. 23.

<sup>3</sup> A position which Bacon in some respects approved. See *Essays*, "Of Ambition." "It is counted by some a weakness in princes to have favourites; but it is of all others the best remedy against ambitious great ones; for when the way of pleasing and displeasing lieth by the favourite, it is impossible any other should be over great."

<sup>4</sup> *Letters and Life*, vi. 278, 294-96, 313.

<sup>5</sup> *Ibid.*, vii. 579-583, analysis of the case by Mr Heath, who expresses a strong opinion against Bacon's action in the matter.

<sup>6</sup> *Ibid.*, vi. 444.

<sup>7</sup> For a full discussion of Bacon's connection with the monopolies, see Gardiner, *Prince Charles*, etc., ii. 355-373. For his opinion of monopolies in general, see *Letters and Life*, vi. 49.

aside, and a weak, featureless production substituted in its place. Nevertheless the new Parliament seemed at first more responsive than might have been looked for. A double subsidy was granted, which was expressly stated to be "not on any consideration or condition for or concerning the Palatinata." The session, however, was not far advanced when the question of patents was brought up; a determined attack was made upon the very ones of which Bacon had been in dread, and it was even proposed to proceed against the referees (Bacon and Montagu) who had certified that there was no objection to them in point of law. This proposal, though pressed by Coke, was allowed to drop; while the king and Buckingham, acting under the advice of Williams, afterwards lord keeper, agreed to give up the monopolies. It was evident, however, that a determined attack was about to be made upon Bacon, and that the proceeding against the referees was really directed against him. It is probable that this charge was dropped because a more powerful weapon had in the meantime been placed in his enemies' hands. This was the accusation of bribery and corrupt dealings in Chancery suits, an accusation apparently wholly unexpected by Bacon, and the possibility of which he seems never to have contemplated until it was actually brought against him. At the beginning of the session a committee had been appointed for inquiring into abuses in the courts of justice. Some illegal practices of certain Chancery officials had been detected and punished by the court itself, and generally there was a disposition to overhaul its affairs, while Coke and Cranfield directly attacked some parts of the chancellor's administration. But on March 14th one Aubrey appeared at the bar of the House, and charged Bacon with having received from him a sum of money while his suit was going on, and with having afterwards decided against him. Bacon's letter<sup>1</sup> on this occasion is worthy of serious attention; he evidently thought the charge was but part of the deliberate scheme to ruin him which had already been in progress. A second accusation (Egerton's case) followed immediately after, and was investigated by the House, who, satisfied that they had just matter for reprehension, appointed the 19th for a conference with the Lords. On that day Bacon, as he had feared, was too ill to attend. He wrote<sup>2</sup> to the Lords excusing his absence, requesting them to appoint a convenient time for his defence and cross-examination of witnesses, and imploring them not to allow their minds to be prejudiced against him, at the same time declaring that he would not "trick up an innocency with cavillations, but plainly and ingeniously declare what he knew or remembered." The charges rapidly accumulated, but Bacon still looked upon them as party moves, and was in hopes of defending himself.<sup>3</sup> Nor did he seem to have

lost his courage, if we are to believe the common reports of the day,<sup>4</sup> though certainly they do not appear worthy of very much credit.

The notes<sup>5</sup> bearing upon the interview which he obtained with the king, show that he had begun to see more clearly the nature and extent of the offences with which he was charged, that he now felt it impossible altogether to exculpate himself, and that his hopes were directed towards obtaining some mitigation of his sentence. The long roll of charges made upon the 19th April finally decided him; he gave up all idea of defence, and wrote to the king begging him to show him favour in this emergency.<sup>6</sup> The next day he sent in a general confession to the Lords,<sup>7</sup> trusting that this would be considered satisfactory. The Lords, however, decided that it was not sufficient as a ground for their censure, and demanded a detailed and particular confession. A list of twenty-eight charges was then sent him, to which an answer by letter was required. On the 30th April his "confession and humble submission"<sup>8</sup> was handed in. In it, after going over the several instances, he says, "I do again confess, that on the points charged upon me, although they should be taken as myself have declared them, there is a great deal of corruption and neglect; for which I am heartily and penitently sorry, and submit myself to the judgment, grace, and mercy of the court."<sup>9</sup> On the 3d May, after considerable discussion, the Lords decided upon the sentence, which was,<sup>10</sup> That he should undergo fine and ransom of £40,000; that he should be imprisoned in the tower during the king's pleasure; that he should be for ever incapable of any office, place, or employment in the state or commonwealth; that he should never sit in parliament, or come within the verge of the court. This heavy sentence was only partially executed. The fine was in effect remitted by the king; imprisonment in the tower lasted for about four days; a general pardon (not of course covering the parliamentary censure) was made out, and though delayed at the seal for a time by Lord Keeper Williams, was passed probably in November 1621. The cause of the delay seems to have lain with Buckingham, whose friendship had cooled, and who had taken offence at the fallen chancellor's unwillingness to part with York House. This difference was finally smoothed over, and it was probably through his influence that Bacon received the much-desired permission to come within the verge of the court. He never again sat in parliament.

So ends this painful episode, which has given rise to the most severe condemnation of Bacon, and which still presents great and perhaps insuperable difficulties. On the whole, the tendency of the most recent and thorough researches has been towards the opinion that Bacon's own account of the matter (from which, indeed, our knowledge of it is chiefly drawn) is substantially correct. He distinguishes three ways in which bribes may be given,<sup>11</sup> and ingeniously

<sup>1</sup> *Letters and Life*, vii. 213: "I know I have clean hands and a clean heart, and I hope a clean house for friends or servants. But Job himself, or whoever was the justest judge, by such hunting for matters against him as hath been used against me, may for a time seem foul, specially in a time when greatness is the mark and accusation is the game."

<sup>2</sup> *Ibid.*, vii. 215-16.

<sup>3</sup> *Ibid.*, vii. 225-26. From the letter to the king (March 26, 1621)—"When I enter into myself, I find not the materials of such a tempter as is comen upon me. I have been (as your majesty knoweth best) never author of any immoderate counsel, but always desired to have things carried *sua vi*. I have been no avaricious oppressor of the people. I have been no haughty or intolerable or hateful man in my conversation or carriage. I have inherited no hatred from my father, but am a good patriot born. Whence should this be? For these are the things that use to raise dialikes abroad. . . . And for the briberies and gifts wherewith I am charged, when the book of hearts shall be opened, I hope I shall not be found to have the troubled fountain of a corrupt heart in a depraved habit of taking rewards to pervert justice, howsoever I may be frail, and partake of the abuse of the times."

<sup>4</sup> *Letters and Life*, vii. 227, and Gardiner, *Prince Charles*, &c., I. 450.

<sup>5</sup> *Ibid.*, vii. 226, 228.

<sup>6</sup> *Ibid.*, vii. 241.

<sup>7</sup> *Ibid.*, vii. 242-4: "It resteth therefore that, without fig-leaves, I do ingeniously confess and acknowledge, that having understood the particulars of the charge, not formally from the House, but enough to inform my conscience and memory, I find matter sufficient and full, both to move me to desert the defence, and to move your lordships to condemn and censure me."

<sup>8</sup> *Ibid.*, vii. 252-252.

<sup>9</sup> *Ibid.*, vii. 261.

<sup>10</sup> *Ibid.*, vii. 270.

<sup>11</sup> *Ibid.*, 225-26: "The first, of bargain and contract for reward to pervert justice, *pendente lite*. The second, where the judge conceives the cause to be at an end, by the information of the party or otherwise, and useth not such diligence as he ought to inquire of it. And the third, where the cause is really ended, and it is *in fine* *frustra* without relation to any precedent promise. . . . For the first of them I take myself to be as innocent as any born upon St Innocent's Day, in my heart. For the second, I doubt on some particulars I may be faulty. And for the last, I conceived it to be no fault, but therein I desire to be better informed, that I may be twice penitent, once for the fact and again for the error."

confesses that his own acts amounted to corruption and were worthy of condemnation. Now, corruption strictly interpreted would imply the deliberate sale of justice, and this Bacon explicitly denies, affirming that he never "had bribe or reward in his eye or thought when he pronounced any sentence or order." When we analyse the specific charges against him, with his answers to them, we find many that are really of little weight. The twenty-eighth and last, that of negligence in looking after his servants, though it did him much harm, may fairly be said to imply no moral blame. The majority of the others are instances of gratuities given after the decision, and it is to be regretted that the judgment of the peers gives us no means of determining how such gifts were looked upon, whether or not the acceptance of them was regarded as a "corrupt" practice. In four cases specifically, and in some others by implication, Bacon confesses that he had received bribes from suitors *pendente lite*. Yet he affirms, as we said before, that his intention was never swayed by a bribe; and so far as any of these cases can be traced, his decisions, often given in conjunction with some other official, are to all appearance thoroughly just. In several cases his judgment appears to have been given against the party bestowing the bribe, and in at least one instance, that of Lady Wharton, it seems impossible to doubt that he must have known when accepting the present that his opinion would be adverse to her cause. Although, then, he felt that these practices were really corrupt, and even rejoiced that his own fall would tend to purify the courts from them,<sup>1</sup> he did not feel that he was guilty of perverting justice for the sake of reward. How far, then, is such defence or explanation admissible and satisfactory? It is clear that two things are to be considered: the one the guilt of taking bribes or presents on any consideration, the other the moral guilt depending upon the wilful perversion of justice. The attempt has sometimes been made to defend the whole of Bacon's conduct on the ground that he did nothing that was not done by many of his contemporaries. Bacon himself disclaims a defence of this nature, and we really have no direct evidence which shows to what extent the offering and receiving of such bribes then prevailed. That the practice was common is indeed implied by the terms in which Bacon speaks of it, and it is not improbable that the fact of these gifts being taken by officials was a thing fairly well known, although all were aware of their illegal character, and it was plain that any public exposure of such dealings would be fatal to the individual against whom the charge was made out.<sup>2</sup> Bacon knew all this; he was well aware that the practice was in itself indefensible,<sup>3</sup> and that his conduct was therefore corrupt and deserving of censure. So far, then, as the mere taking of bribes is concerned, he would permit no defence, and his own confession and judgment on his actions contain as severe a condemnation as has ever been passed upon him. Yet in the face of this he does not hesitate to call himself "the justest chancellor that hath been in the five changes since Sir Nicholas Bacon's time";<sup>4</sup> and this on the plea that

his intentions had always been pure, and had never been affected by the presents he received. His justification has been set aside by modern critics, not on the ground that the evidence demonstrates its falsity,<sup>5</sup> but because it is inconceivable or unnatural that any man should receive a present from another, and not suffer his judgment to be swayed thereby. It need hardly be said that such an *a priori* conviction is not a sufficient basis on which to found a sweeping condemnation of Bacon's integrity as an administrator of justice. On the other hand, even if it be admitted to be possible and conceivable that a present should be given by a suitor simply as seeking favourable consideration of his cause, and not as desirous of obtaining an unjust decree, and should be accepted by the judge on the same understanding, this would not entitle one absolutely to accept Bacon's statement. Further evidence is necessary in order to give foundation to a definite judgment either way; and it is extremely improbable, nay, almost impossible, that such can ever be produced. In these circumstances, due weight should be given to Bacon's own assertions of his perfect innocence and purity of intention; they ought not to be put out of court unless found in actual contradiction to the facts; and the reverse of this is the case, so far as has yet appeared.<sup>6</sup>

The remainder of his life, though still harassed by want of means, for James was not liberal, was spent in work far more valuable to the world than anything he had accomplished in his high office. In March 1622 he presented to Prince Charles his *History of Henry VII.*; and immediately, with unwearied industry, set to work to complete some portions of his great work. In November 1622 appeared the *Historia Ventorum*; in January 1623, the *Historia Vita et Mortis*; and in October of the same year, the *De Augmentis Scientiarum*, a Latin translation, with many additions, of the *Advancement*. Finally, in December 1624, he published his *Apophthegms*, and *Translations of some of the Psalms*; and, in 1625, a third and enlarged edition of the *Essays*.

Busily occupied with these labours, his life now drew rapidly to a close. In March 1626 he came to London, and when driving one day near Highgate, was taken with a desire to discover whether snow would act as an anti-septic. He stopped his carriage, got out at a cottage, purchased a fowl, and with his own hands assisted to stuff it with snow. He was seized with a sudden chill, and became so seriously unwell that he had to be conveyed to Lord Arundel's house, which was near at hand. Here his illness increased, the cold and chill brought on bronchitis and he died, after a few days' suffering, on the 9th April 1626.

#### BACON'S WORKS AND PHILOSOPHY.

A complete survey of Bacon's works and an estimate of his place in literature and philosophy are matters for a volume. It is here proposed merely to classify the works, to indicate their general character, and to enter somewhat more in detail upon what he himself regarded as his great achievement,—the reorganisation of the sciences, and the exposition of a new method by which the human mind might proceed with security and certainty towards the true end of all human thought and action.

<sup>1</sup> Or on the ground that there was a distinct rule forbidding chancellors and the like officials to take presents. This does not seem to have been the case, if we may judge from what Bacon says, *Letters and Life*, vii. 233.

<sup>2</sup> Not only do the cases, so far as they are known, support Bacon's plea of innocence, but it is remarkable that no attempt at a reversal of any of his numerous decrees appears to have been successful. Had his decrees been wilful perversions of justice, it is scarcely conceivable that some of them should not have been overturned. See *Letters and Life*, vii. 555-562.

<sup>1</sup> *Letters and Life*, vii. 242.

<sup>2</sup> *Ibid.*, vii. 244: "Neither will your lordships forget that there are *vicia temporis* as well as *vicia hominis*, and that the beginning of reformations hath the contrary power to the pool of Bethesda, for that had strength to cure only him that was first cast in, and this hath commonly strength to hurt him only that is first cast in."

<sup>3</sup> See, among many other passages, *Essays*, "Of Great Place": "For corruptions do not only bind their own hands or thy servant's hands from taking, but bind the hands of suitors also from offering; for integrity used doth the one; but integrity professed, and with a manifest detestation of bribery, doth the other; and avoid not only the fault but the suspicion."

<sup>4</sup> *Cf. Letters and Life*, vii. 560: "I was the justest judge that was in England these fifty years; but it was the justest censure in Parliament that was these two hundred years."

Putting aside the letters and occasional writings, we may conveniently distribute the other works into three classes, *Professional, Literary, Philosophical*. Of the Professional works, which include the *Reading on the Statute of Uses*, the *Maxims of Law*, and the treatise (possibly spurious) on the *Use of the Law*, only experts can speak with confidence; and their opinion, so far as it has yet been given, coincides to some extent with Bacon's own estimate of his powers as a lawyer. "I am in good hope," he says, "that when Sir Edward Coke's reports and my rules and decisions shall come to posterity, there will be (whatsoever is now thought) question who was the greater lawyer." If Coke's reports show completer mastery of technical details, greater knowledge of precedent, and more of the dogged grasp of the letter than do Bacon's legal writings, there can be no dispute that the latter exhibit an infinitely more comprehensive intelligence of the abstract principles of jurisprudence, with a richness and ethical fullness that more than compensate for their lack of dry legal detail. Bacon seems indeed to have been a lawyer of the first order, with a keen scientific insight into the bearings of isolated facts, and a power of generalisation which admirably fitted him for the self-imposed task, unfortunately never completed, of digesting or codifying the chaotic mass of the English law.

Among the literary works are included all that he himself designated moral and historical pieces, and to these may be added some theological and minor writings, such as the *Apophthegms*. Of the moral works the most valuable are the *Essays*. It is impossible to praise too highly writings which have been so widely read and universally admired. The matter is of the familiar, practical kind, that "comes home to men's bosoms." The thoughts are weighty, and even when not original, have acquired a peculiar and unique tone or cast by passing through the crucible of Bacon's mind. A sentence from the *Essays* can rarely be mistaken for the production of any other writer. The short, pithy sayings,

"Jewels, five words long,  
That on the stretched forefinger of all time  
Sparkle for ever."

have become popular mottoes and household words. The style is quaint, original, abounding in allusions and witticisms, and rich, even to gorgeousness, with piled-up analogies and metaphors.<sup>1</sup> The first edition contained only ten essays, but the number was increased in 1612 to thirty-eight, and in 1625 to fifty-eight. The short tract, *Colours of Good and Evil* which with the *Meditationes Sacrae* originally accompanied the *Essays*, was afterwards incorporated with the *De Augmentis*. Along with these works may be classed the curiously learned piece, *De Sapientia Veterum*, in which he works out a favourite idea, that the mythological fables of the Greeks were allegorical and concealed the deepest truths of their philosophy. As a scientific explanation of the myths the theory is of no value, but it affords fine scope for the exercise of Bacon's unrivalled power of detecting analogies in things apparently most dissimilar. The *Apophthegms*, though hardly deserving Macaulay's praise of being the best collection of jests in the world, contain a number of those significant anecdotes which Bacon used with such effect in his other writings. Of the historical works, besides a few fragments of the projected history of Britain, there remains the *History of*

<sup>1</sup> The peculiarities of Bacon's style were noticed very early by his contemporaries. (See *Letters and Life*, i. 268.) Balesh and Jonson have both recorded their opinions of it, but no one, it seems to us, has characterised it more happily than his friend, Sir Tobie Matthews, "A man so rare in knowledge, of so many several kinds, endued with the facility and felicity of expressing it all in so elegant, significant, so abundant, and yet so choice and ravishing a way of words, of metaphors, of allusions, as perhaps the world hath not seen since it was a world."—"Address to the Reader" prefixed to *Collection of English Letters*, 1660.

*Henry VII.*, a valuable work, giving a clear and animated narrative of the reign, and characterising Henry with great skill. The style is in harmony with the matter, vigorous and flowing, but naturally with less of the quaintness and richness suitable to more thoughtful and original writings. The series of the literary works is completed by the minor treatises on theological or ecclesiastical questions. Some of the latter, included among the occasional works, are admirably sagacious and prudent, and deserve careful study. Of the former, the principal specimens are the *Meditationes Sacrae* and the *Confession of Faith*. The *Paradoxes* (Characters of a believing Christian in paradoxes, and seeming contradictions), which was often and justly suspected, has been conclusively proved by Mr Grosart not to be the work of Bacon.

*Philosophical Works*.—The great mass of Bacon's writings consists of treatises or fragments, which either formed integral parts of his grand comprehensive scheme, or were closely connected with it. More exactly they may be classified, as is done by the most recent editors, under three heads:—A. Writings which actually formed part of the *Instauratio Magna*; B. Writings originally intended to form parts of the *Instauratio*, but which were afterwards superseded or thrown aside; C. Works connected with the *Instauratio*, but not directly included in its plan.

To begin with the second of these classes, we have under it some important tracts, which certainly contain little, if anything, that is not afterwards taken up and expanded in the more elaborate works, but which are not undeserving of attention, from the difference in the point of view and method of treatment. The most valuable of them are—(1.) *The Advancement of Learning*, of which no detailed account need be given, as it is completely worked up into the *De Augmentis*, and takes its place as the first part of the *Instauratio*. (2.) *Valerius Terminus*, a very remarkable piece, composed probably about 1603, though perhaps retouched at a later period. It contains a brief and somewhat obscure outline of the first two parts in the *Instauratio*, and is of importance as affording us some insight into the gradual development of the system in Bacon's own mind. (3.) *Temporis Partus Maculæ*, another curious fragment, remarkable not only from its contents, but from its style, which is arrogant and offensive, in this respect unlike any other writing of Bacon's. The adjective *maculæ* points to the power of bringing forth fruit possessed by the new philosophy, and perhaps indicates that all previous births of time were to be looked upon as feminine or imperfect; it is used in a somewhat similar sense in *Letters and Life*, vi. 183, "In verbis maculis, no flourishing or painted words, but such words as are fit to go before deeds." (4.) *Rodargutio Philosophiarum*, a highly finished piece in the form of an oration, composed probably about 1608 or 1609, and containing in pretty full detail much of what afterwards appears in connection with the *Idola Theatri* in book i. of the *Novum Organum*. (5.) *Cogitata et Visa*, perhaps the most important of the minor philosophical writings, dating from 1607 (though possibly the tract in its present form may have been to some extent altered), and containing in weighty and sonorous Latin the substance of the first book of the *Organum*. (6.) *The Descriptio Globi Intellectualis*, which is to some extent intermediate between the *Advancement* and the *De Augmentis*, goes over in detail the general classification of the sciences, and enters particularly on some points of minor interest. (7.) The brief tract *De Interpretatione Naturæ Sententia Duodecim* is evidently a first sketch of part of the *Novum Organum*, and in phraseology is almost identical with it. (8.) A few smaller pieces, such as the *Inquiritio de Motu*, the *Calor et Frigus*, the *Historia Soni et Auditus*, and the *Phænomena Universi*,

are early specimens of his *Natural History*, and exhibit the first tentative applications of the new method.

The third great division of the philosophical works consists of treatises on subjects connected with the *Instauratio*, but not forming part of it. It is not necessary to characterise these at any length. The most interesting, and in many respects the most remarkable, is the philosophic romance, the *New Atlantis*, a description of an ideal state in which the principles of the new philosophy are carried out by political machinery, and under state guidance, and where many of the results contemplated by Bacon are in imagination attained. The work was to have been completed by the addition of a second part, treating of the laws of a model commonwealth, which was never written. Another important tract is the *De Principiis atque Originibus secundum Fabulas Cupidinis et Casti*, where, under the disguise of two old mythological stories, he (in the manner of the *Sapientia Veterum*) finds the deepest truths concealed. The tract is unusually interesting, for in it he discusses at some length the limits of science, the origin of things, and the nature of primitive matter, giving at the same time full notices of Democritus among the ancient philosophers and of Telesius among the modern. Deserving of attention are also the *Cogitationes de Natura Rerum*, probably written early, perhaps in 1605, and the treatise on the theory of the tides, *De Fluxu et Refluxu Maris*, written probably about 1616.

The philosophical works which form part of the *Instauratio* must of course be classed according to the positions which they respectively hold in that scheme of the sciences. Before entering on an account of Bacon's object and method, it is necessary to give the general outline of his arrangement.

The great work, the reorganisation of the sciences, and the restoration of man to that command over nature which he had lost by the fall, consisted in its final form of six divisions.

I. *Partitiones Scientiarum*, a survey of the sciences, either such as then existed or such as required to be constructed afresh—in fact, an inventory of all the possessions of the human mind. This famous classification<sup>1</sup> on which this survey proceeds is based upon an analysis of the faculties and objects of human knowledge. This division is represented by the *De Augmentis Scientiarum*.

II. *Interpretatio Naturæ*.—After the survey of all that has yet been done in the way of discovery or invention, comes the new method, by which the mind of man is to be trained and directed in its progress towards the renovation of science. This division is represented, though only imperfectly, by the *Novum Organum*, particularly book ii.

III. *Historia Naturalis et Experimentalis*.—The new method is valueless, because inapplicable, unless it be supplied with materials duly collected and presented—in fact, unless there be formed a competent natural history of the *Phænomena Universi*. A short introductory sketch of the requisites of such a natural history, which, according to Bacon, is essential, necessary, the *basis totius negotii*, is given in the tract *Parascève*, appended to the *Novum Organum*. The principal works intended to form portions of the history, and either published by himself or left in manuscript, are *Historia Ventorum*, *Historia Vitæ et Mortis*, *Historia Densæ et Raris*, and the extensive collection of facts and observations entitled *Sylva Sylvarum*.

IV. *Scala Intellectus*.—It might have been supposed that the new philosophy could now be inaugurated.

Materials had been supplied, along with a new method by which they were to be treated, and naturally the next step would be the finished result. But for practical purposes Bacon interposed two divisions between the preliminaries and the philosophy itself. The first was intended to consist of types or examples of investigations conducted by the new method, serviceable for keeping the whole process vividly before the mind, or, as the title indicates, such that the mind could run rapidly up and down the several steps or grades in the process. Of this division there seems to be only one small fragment, the *Filum Labyrinthi*, consisting of but two or three pages.

V. *Prodromi*, forerunners of the new philosophy. This part, strictly speaking, is quite extraneous to the general design. According to the *Distributio Operis*,<sup>2</sup> it was to contain certain speculations of Bacon's own, not formed by the new method, but by the unassisted use of his understanding. These, therefore, form temporary or uncertain anticipations of the new philosophy. There is extant a short preface to this division of the work, and according to Mr Spedding, some of the miscellaneous treatises, such as *De Principiis*, *De Fluxu et Refluxu*, *Cogitationes de Natura Rerum*, may probably have been intended to be included under this head. This supposition receives some support from the manner in which the fifth part is spoken of in the *Novum Organum*, i. 116.

VI. The new philosophy, which is the work of future ages, and the result of the new method.

Bacon's grand motive in his attempt to found the sciences anew was the intense conviction that the knowledge man possessed was of little service to him. "The knowledge whereof the world is now possessed, especially that of nature, extendeth not to magnitude and certainty of works."<sup>3</sup> Man's sovereignty over nature, which is founded on knowledge alone, had been lost, and instead of the free relation between things and the human mind, there was nothing but vain notions and blind experiments. To restore the original commerce between man and nature, and to recover the *imperium hominis*, is the grand object of all science. The want of success which had hitherto attended efforts in the same direction had been due to many causes, but chiefly to the want of appreciation of the nature of philosophy and its real aim. Philosophy is not the science of things divine and human; it is not the search after truth. "I find that even those that have sought knowledge for itself, and not for benefit or ostentation, or any practical enablement in the course of their life, have nevertheless propounded to themselves a wrong mark, namely, satisfaction (which men call Truth) and not operation."<sup>4</sup> "Is there any such happiness as for a man's mind to be raised above the confusion of things, where he may have the prospect of the order of nature and error of man! But is this a view of delight only and not of discovery! of contentment and not of benefit! Shall he not as well discern the riches of nature's warehouse as the beauty of her shop! Is truth ever barren! Shall he not be able thereby to produce worthy effects, and to endow the life of man with infinite commodities!"<sup>5</sup> Philosophy is altogether practical; it is of little matter to the fortunes of humanity what abstract notions one may entertain concerning the nature and the principles of things.<sup>6</sup> This truth, however, has never yet been recognised; it has not yet been seen that the true aim of all science is "to endow the condition and life of man with:

<sup>1</sup> See also "Letter to Fulgentius," *Letters and Life*, vii. 532.

<sup>2</sup> *Ful. Lab.*; *Cog. et Vis.*, i.; *of. Pref. to Inst. Mag.*

<sup>3</sup> *Val. Ter.*, 232; *of. N. O.*, l. 124.

<sup>4</sup> *Letters*, i. 128.

<sup>5</sup> *N. O.*, l. 116.

<sup>6</sup> *Ful. Lab.*, 5; *of. N. O.*, l. 81; *Val. Ter. (Works, iii. 235)*; *Advancement*, b. i. (*Works*, iii. 294).

<sup>1</sup> As is well known, the division of the sciences adopted in the great French *Encyclopédie* was founded upon this classification of Bacon's. See Diderot's *Prospectus* (*Œuvres*, iii.), and D'Alembert's *Discours* (*Œuvres*, i.) The scheme should be compared with later attempts of the same nature by Ampère, Cournot, Comte, and H. Spencer.

new powers or works,"<sup>1</sup> or "to extend more widely the limits of the power and greatness of man."<sup>2</sup> Nevertheless, it is not to be imagined that by this being proposed as the great object of search there is thereby excluded all that has hitherto been looked upon as the higher aims of human life, such as the contemplation of truth. Not so, but by following the new aim we shall also arrive at a *true* knowledge of the universe in which we are, for without knowledge there is no power; truth and utility are in ultimate aspect the same; "works themselves are of greater value as pledges of truth than as contributing to the comforts of life."<sup>3</sup> Such was the conception of philosophy with which Bacon started, and in which he felt himself to be thoroughly original. As his object was new and hitherto unproposed, so the method he intended to employ was different from all modes of investigation hitherto attempted. "It would be," as he says, "an unsound fancy and self-contradictory, to expect that things which have never yet been done can be done except by means which have never yet been tried."<sup>4</sup> There were many obstacles in his way, and he seems always to have felt that the first part of the new scheme must be a *pars destruens*, a destructive criticism of all other methods. Opposition was to be expected, not only from previous philosophies, but especially from the human mind itself. In the first place, natural antagonism might be looked for from the two opposed sects, the one of whom, in despair of knowledge, maintained that all science was impossible; while the other, resting on authority and on the learning that had been handed down from the Greeks, declared that science was already completely known, and consequently devoted their energies to methodising and elaborating it. Secondly, within the domain of science itself, properly so called, there were two "kinds of rovers" who must be dismissed. The first were the speculative or logical philosophers, who construe the universe *ex analogia hominis*, and not *ex analogia mundi*, who fashion nature according to preconceived ideas, and who employ in their investigations syllogism and abstract reasoning. The second class, who were equally offensive, consisted of those who practised blind experience, which is mere groping in the dark (*vaga experientia mera palpatio est*), who occasionally hit upon good works or inventions, which, like Atalanta's apples, distracted them from further steady and gradual progress towards universal truth. In place of these straggling efforts of the unassisted human mind, a graduated system of helps was to be supplied, by the use of which the mind, when placed on the right road, would proceed with unerring and mechanical certainty to the invention of new arts and sciences.

Such were to be the peculiar functions of the new method, though it has not definitely appeared what that method was, or to what objects it could be applied. But, before proceeding to unfold his method, Bacon found it necessary to enter in considerable detail upon the general subject of the obstacles to progress, and devoted nearly the whole of the first book of the *Organum* to the examination of them. This discussion, though strictly speaking extraneous to the scheme, has always been looked upon as a most important part of his philosophy, and his name is perhaps as much associated with the doctrine of *Idola* as with the theory of induction or the classification of the sciences.

The doctrine of the kinds of fallacies or general classes of errors into which the human mind is prone to fall, appears in many of the works written before the *Novum Organum*, and the treatment of them varies in some respects. The classification in the *Organum*, however, not only has the

author's sanction, but has received the stamp of historical acceptance; and comparison of the earlier notices, though a point of literary interest, has no important philosophic bearing. The *Idola*,<sup>5</sup> false notions of things, or erroneous ways of looking at nature, are of four kinds: the first two innate, pertaining to the very nature of the mind and not to be eradicated; the third creeping insensibly into men's minds, and hence in a sense innate and inseparable; the fourth imposed from without. The first kind are the *Idola Tribus*, fallacies incident to humanity or the race in general. Of these, the most prominent are—the proneness of the mind to suppose in nature greater order and regularity than there actually is; the tendency to support a preconceived opinion by affirmative instances, neglecting or throwing out of account all negative or opposed cases; and the tendency to generalise from few observations, or to give reality to mere abstractions, figments of the mind. manifold errors also result from the weakness of the senses, which affords scope for mere conjecture; from the influence exercised over the understanding by the will and passions; from the restless desire of the mind to penetrate to the ultimate principles of things; and from the belief that "man is the measure of the universe," whereas, in truth, the world is received by us in a distorted and erroneous manner. The second kind are the *Idola Specus*, idols of the cave, or errors incident to the peculiar mental or bodily constitution of each individual, for according to the state of the individual's mind is his view of things. Errors of this class are innumerable, because there are numberless varieties of disposition; but some very prominent specimens can be indicated. Such are the tendency to make all things subservient to, or take the colour of some favourite subject, the extreme fondness and reverence either for what is ancient or for what is modern, and excess in noting either differences or resemblances amongst things. A practical rule for avoiding these is also given: "In general let every student of nature take this as a rule, that whatever his mind seizes and dwells upon with particular satisfaction is to be held in suspicion."<sup>6</sup> The third class are the *Idola Fori*, idols of the market-place, i.e., errors arising from the influence exercised over the mind by mere words. This, according to Bacon, is the most troublesome kind of error, and has been especially fatal in philosophy. For words introduce a fallacious mode of looking at things in two ways: first, there are some words that are really merely names for non-existent things, which are yet supposed to exist simply because they have received a name; secondly, there are names hastily and unskilfully abstracted from a few objects and applied recklessly to all that has the faintest analogy with these objects, thus causing the grossest confusion. The fourth and last class are the *Idola Theatri*, idols of the theatre, i.e., fallacious modes of thinking resulting from received systems of philosophy, and from erroneous methods of demonstration. The criticism of the demonstrations is introduced later in close connection with Bacon's new method; they are the rival modes of procedure, to which his own is definitely opposed. The philosophies which are "redargued" are divided into three classes, the sophistical, of which the best example is Aristotle, who forces nature into his abstract schemata and thinks to ex-

<sup>5</sup> The word *Idolon* is manifestly borrowed from Plato. It is used twice in connection with the Platonic Ideas (*N. O.*, I. 23, 124), and is contrasted with them as the false appearance. The *εἰκων* with Plato is the fleeting, transient image of the real thing, and the passage evidently referred to by Bacon is that in the *Rep.* vii. 516 A. "καὶ ἄλλοτε μὲν τὰς αἰδέας ἐν βίῳ καὶ ἐν ὄντι, καὶ μετὰ τοῦτο ἐν τοῖς εἰκόσι τὰ ἐν τῷ ἀποθανεῖν καὶ τὰ ἐν ἄλλοις εἰκόσι, ὅπως δὲ ἔσται." It is explained well in the *Advancement*, bk. I (*Works*, III. 287).

<sup>6</sup> *N. O.*, I. 58.

<sup>1</sup> *N. L.*, 5; cf. *N. O.*, I. 81; *Val. Ter.* (*Works*, III. 222, 233); *New Atlantis* (*Works*, III. 156).

<sup>2</sup> *N. O.*, I. 116.

<sup>3</sup> *Ibid.*, I. 124.

<sup>4</sup> *Ibid.*, I. 6.



plain by definitions; the empirical, which from few and limited experiments leaps at once to general conclusions; and the superstitious, which corrupts philosophy by the introduction of poetical and theological notions.

Such are the general causes of the errors that infest the human mind; by their exposure the way is cleared for the introduction of the new method. The nature of this method cannot be understood until it is exactly seen to what it is to be applied. What idea had Bacon of science, and how is his method connected with it? Now, the science<sup>1</sup> which was specially and invariably contemplated by him was Natural Philosophy, the great mother of all the sciences; it was to him the type of scientific knowledge, and its method was the method of all true science. To discover exactly the characteristics and the object of natural philosophy it is necessary to examine the place it holds in the general scheme furnished in the *Advancement* or *De Augmentis*. All human knowledge, it is there laid down, may be referred to man's memory, or imagination, or reason. In the first, the bare facts presented to sense are collected and stored up; the exposition of them is History, which is either natural or civil. In the second, the materials of sense are separated or divided in ways not corresponding to nature but after the mind's own pleasure, and the result is Poesy or feigned history. In the third, the materials are worked up after the model or pattern of nature, though we are prone to err in the progress from sense to reason; the result is Philosophy, which is concerned either with God, with nature, or with man, the second being the most important. Natural philosophy is again divided into speculative or theoretical, and operative or practical, according as the end is contemplation or works. Speculative or theoretical natural philosophy has to deal with natural substances and qualities, and is subdivided into physics and metaphysics. Physics inquires into the efficient and material causes of things; metaphysics, into the formal and final causes. The principal objects of physics are concrete substances, or abstract though physical qualities. The research into abstract qualities, the fundamental problem of physics, comes near to the metaphysical study of *forms*, which indeed differs from the first only in being more general, and in having as its result a *form* strictly so called, i.e., a nature or quality which is a limitation or specific manifestation of some higher and better known genus. Natural philosophy is, therefore, in ultimate resort the study of *forms*, and, consequently, the fundamental problem of philosophy in general is the discovery of these *forms*.

"On a given body to generate or superinduce a new nature or nature, is the work and aim of human power. . . . Of a given nature to discover the form or true specific difference, or nature-engendering nature (*natura naturans*) or source of emanation (for these are the terms which are nearest to a description of the thing), is the work and aim of human knowledge."<sup>2</sup>

The questions, then, whose answers give the key to the whole Baconian philosophy, may be put briefly thus—What are forms? and how is it that knowledge of them solves both the theoretical and the practical problem of science? Bacon himself, as may be seen from the passage quoted above, finds great difficulty in giving an adequate and exact definition of what he means by a form. As a general description, the following passage from the *Novum Organum*, ii. 4., may be cited:—

"The form of a nature is such that given the form the nature infallibly follows. . . . Again, the form is such that if it be taken away the nature infallibly vanishes. . . . Lastly, the true form is such that it deduces the given nature from some source of being which is inherent in more natures, and which is better known in the natural order of things than the form itself."<sup>3</sup>

From this it would appear that, since by a *nature* is meant some sensible quality, superinduced upon, or possessed by, a body, so by a form we are to understand the cause of that nature, which cause is itself a determinate case or manifestation of some general or abstract quality inherent in a greater number of objects. But all these are mostly marks by which a form may be recognised, and do not explain what the form really is. A further definition is accordingly attempted in Aph. 13:—

"The form of a thing is the very thing itself, and the thing differs from the form no otherwise than as the apparent differs from the real, or the external from the internal, or the thing in reference to the man from the thing in reference to the universe."

This throws a new light on the question, and from it the inference at once follows, that the forms are the permanent causes or substances underlying all visible phenomena, which are merely manifestations of their activity. Are the forms, then, forces? At times it seems as if Bacon had approximated to this view of the nature of things, for in several passages he identifies forms with laws of activity. Thus, he says—

"When I speak of forms I mean nothing more than those laws and determinations of absolute actuality which govern and constitute any simple nature, as heat, light, weight, in every kind of matter and subject that is susceptible of them. Thus the form of heat or the form of light is the same thing as the law of heat or the law of light."<sup>4</sup> "Matter rather than forms should be the object of our attention, its configurations and changes of configuration, and simple action, and law of action or motion; for forms are figments of the human mind, unless you will call those laws of action forms."<sup>5</sup> "Forms or true differences of things, which are in fact laws of pure act."<sup>6</sup> "For though in nature nothing really exists besides individual bodies, performing pure individual acts according to a fixed law, yet in philosophy this very law, and the investigation, discovery, and explanation of it, is the foundation as well of knowledge as of operation. And it is this law, with its clauses, that I mean when I speak of forms."<sup>7</sup>

Several important conclusions may be drawn from these passages. In the first place, it is evident that Bacon, like the Atomical school, of whom he highly approved, had a clear perception and a firm grasp of the *physical* character of natural principles; his *forms* are no ideas or abstractions, but highly general physical properties. Further, it is hinted that these general qualities may be looked upon as the modes of action of simple bodies. This fruitful conception, however, Bacon does not work out; and though he uses the word cause, and identifies form with formal cause, yet it is perfectly apparent that the modern notions of cause as dynamical, and of nature as in a process of flow or development, are foreign to him, and that in his view of the ultimate problem of science, cause meant *causa immanens*, or underlying substance, effects were not consequents but manifestations, and nature was regarded in a purely statical aspect. That this is so appears even more clearly when we examine his general conception of the unity, gradation, and function of the sciences. That the sciences are organically connected is a thought common to him and to his distinguished predecessor Roger Bacon. "I that hold it for a great impediment towards the advancement and further invention of knowledge, that particular arts and sciences have been disincorporated from general knowledge, do not understand one and the same thing which Cicero's discourse and the note and conceit of the Grecians in their word *circles learning* do intend. For I mean not that use which one science hath of another for ornament or help in practice; but I mean it directly of that use by way of supply of light and information, which the particulars and instances of one science do yield and present for the framing or correcting of the axioms of an-

explained by Bacon. Like his classification of causes, and in some degree his notion of form itself, it comes from Aristotle. See *Am. Post.*, 71, § 23; *Topic.*, 141, § 5; *Met. Nic.*, 1095, a 30.

<sup>1</sup> *N. O.*, ii. 17. <sup>2</sup> *Ibid.*, i. 51. <sup>3</sup> *Ibid.*, i. 75. <sup>4</sup> *Ibid.*, ii. 2.

<sup>1</sup> *N. O.*, i. 79, 80, 98, 108.

<sup>2</sup> *Ibid.*, ii. 1.

<sup>3</sup> This better known in the order of nature is nowhere satisfactorily

other science in their very truth and notion."<sup>1</sup> In accordance with this, Bacon placed at the basis of the particular sciences which treat of God, nature, and man, one fundamental doctrine, the *Prima Philosophia*, or first philosophy, the function of which was to display the unity of nature by connecting into one body of truth such of the highest axioms of the subordinate sciences as were not special to one science, but common to several.<sup>2</sup> This first philosophy had also to investigate what are called the adventitious or transcendental conditions of essences, such as Much, Little, Like, Unlike, Possible, Impossible, Being, Nothing, the logical discussion of which certainly belonged rather to the laws of reasoning than to the existence of things, but the physical or real treatment of which might be expected to yield answers to such questions as, Why certain substances are numerous, others scarce? or why, if like attracts like, iron does not attract iron? Following this summary philosophy come the sciences proper, rising like a pyramid in successive stages, the lowest floor being occupied by natural history or experience, the second by physics, the third, which is next the peak of unity, by metaphysics.<sup>3</sup> The knowledge of the peak, or of the one law which binds nature together, is perhaps denied to man. Of the sciences, physics, as has been already seen, deals with the efficient and material, *i. e.*, with the variable and transient, causes of things. But its inquiries may be directed either towards concrete bodies or towards abstract qualities. The first kind of investigation rises little above mere natural history; but the other is more important, and paves the way for metaphysics. It handles the configurations and the appetites or motions of matter. The configurations, or inner structures of bodies, include dense, rare, heavy, light, hot, cold, &c., in fact, what are elsewhere called simple natures. Motions<sup>4</sup> are either simple or compound, the latter being the sum of a number of the former. In physics, however, these matters are treated only as regards their material or efficient causes, and the result of inquiry into any one case gives no general rule, but only facilitates invention in some similar instance. Metaphysics, on the other hand, treats of the formal or final cause<sup>5</sup> of these same substances and qualities, and results in a general rule. With regard to forms, the investigation may be directed either towards concrete bodies or towards qualities. But the forms of substances "are so perplexed an" complicated, that it is either vain to inquire into them at all, or such inquiry as is possible should be put off for a time, and not entered upon till forms of a more simple nature have been rightly investigated and discussed."<sup>6</sup> "To inquire into the form of a lion, of an oak, of gold, nay, even of water or air, is a vain pursuit; but to inquire the form of dense, rare, hot, cold, &c., as well configurations as motions, which in treating of physics I have in great part enumerated (I call them forms of the first class), and which (like the

letters of the alphabet) are not many, and yet make up and sustain the essences and forms of all substances—this, I say, it is which I am attempting, and which constitutes and defines that part of metaphysics of which we are now inquiring." Physics inquires into the same qualities, but does not push its investigations into ultimate reality or reach the more general causes. We thus at last attain a definite conclusion with regard to forms, and it appears clear that in Bacon's belief the true function of science was the search for a few fundamental physical qualities, highly abstract and general, the combinations of which give rise to the simple natures and complex phenomena around us. His general conception of the universe may therefore be called mechanical or statical; the cause of each phenomenon is supposed to be actually contained in the phenomenon itself, and by a sufficiently accurate process could be sifted out and brought to light. As soon as the causes are known man regains his power over nature, for "whosoever knows any form, knows also the utmost possibility of superinducing that nature upon every variety of matter, and so is less restrained and tied in operation either to the basis of the matter or to the condition of the efficient."<sup>7</sup>

Nature thus presented itself to Bacon's mind as a huge congeries of phenomena, the manifestations of some simple and primitive qualities, which were hid from us by the complexity of the things themselves. The world was a vast labyrinth, amid the windings of which we require some clue or thread whereby we may track our way to knowledge and thence to power. This thread, the *filum labyrinthi*, is the new method of induction. But, as has been frequently pointed out, the new method could not be applied until facts had been observed and collected. This is an indispensable preliminary. "Man, the servant and interpreter of nature, can do and understand so much, and so much only, as he has observed in fact or in thought of the course of nature; beyond this he neither knows anything nor can do anything." The proposition that our knowledge of nature necessarily begins with observation and experience, is common to Bacon and many contemporary reformers of science, but he laid peculiar stress upon it, and gave it a new meaning. What he really meant by observation was a competent natural history or collection of facts. "The firm foundations of a purer natural philosophy are laid in natural history."<sup>8</sup> "First of all we must prepare a *natural and experimental history*, sufficient and good; and this is the foundation of all."<sup>9</sup> The senses and the memory, which collect and store up facts, must be assisted; there must be a *ministration* of the senses and another of the memory. For not only are instances required, but these must be arranged in such a manner as not to distract or confuse the mind, *i. e.*, tables and arrangements of instances must be constructed. In the preliminary collection the greatest care must be taken, that the mind be absolutely free from preconceived ideas; nature is only to be conquered by obedience; man must be merely receptive. "All depends on keeping the eye steadily fixed upon the facts of nature, and so receiving their images simply as they are; for God forbid that we should give out a dream of our own imagination for a pattern of the world; rather may He graciously grant to us to write an apocalypse or true vision of the footsteps of the Creator imprinted on his creatures."<sup>10</sup> Concealed among the facts presented to sense are the causes or forms, and

<sup>1</sup> *Valerius Terminus*, iii. 228-29.

<sup>2</sup> *Cf. N. O.*, ii. 27. Bacon nowhere enters upon the questions of how such a science is to be constructed, and how it can be expected to possess an independent method while it remains the mere receptacle for the generalisations of the several sciences, and consequently has a content which varies with their progress. His whole conception of *Prima Philosophia* should be compared with such a modern work as the *First Principles* of Herbert Spencer.

<sup>3</sup> It is to be noticed that this scale of nature corresponds with the scale of ascending axioms.

<sup>4</sup> *Cf. also*, for motions, *N. O.*, ii. 48.

<sup>5</sup> The knowledge of final causes does not lead to works, and the consideration of them must be rigidly excluded from physics. Yet there is no opposition between physical and final causes; in ultimate resort the mind is compelled to think the universe as the work of reason, to refer facts to God and Providence. The idea of final cause is also fruitful in sciences which have to do with human action. (*Cf. De Aug.*, iii. *ea.* 4, 5; *Nov. Org.*, i. 48, ii. 2.)

<sup>6</sup> *De Aug.*, iii. 4. In the *Advancement* (*Works*, iii. 355) it is distinctly said that they are not to be inquired into. One can hardly see how the Baconian method could have applied to concrete substances.

<sup>7</sup> Thus the last step in the theoretical analysis gives the first means for the practical operation. *Cf. Aristotle, Eth. Nic.*, iii. 3, 13, "ὅτι θεῶν ἐν τῇ ἀναλύσει πρῶτον εἶναι ἐν τῇ γενέσει." *Cf. also Nov. Org.*, i. 103.

<sup>8</sup> *Cogitationes* (*Works*, iii. 187).

<sup>9</sup> *N. O.*, ii. 10.

<sup>10</sup> *Pref. to Instaur.* *Cf. Valerius Term. (Works, iii. 224), and N. O.*, i. 68, 124.

the problem therefore is so to analyse experience,<sup>1</sup> so to break it up into pieces, that we shall with certainty and mechanical ease arrive at a true conclusion. This process, which forms the essence of the new method, may in its entirety, as a ministration to the reason, be called a logic; but it differs widely from the ordinary or school logic in end, method, and form. Its aim is to acquire command over nature by knowledge, and to invent new arts, whereas the old logic strove only after dialectic victories and the discovery of new arguments. In method the difference is even more fundamental. Hitherto the mode of demonstration had been by the syllogism; but the syllogism is, in many respects, an incompetent weapon. It is compelled to accept its first principles on trust from the science in which it is employed; it cannot cope with the subtlety of nature; and it is radically vitiated by being founded on hastily and inaccurately abstracted notions of things. For a syllogism consists of propositions, propositions of words, and words are the symbols of notions. Now the first step in accurate progress from sense to reason, or true philosophy, is to frame a *bona notio* or accurate conception of the thing; but the received logic never does this. It flies off at once from experience and particulars to the highest and most general propositions, and from these descends, by the use of middle terms, to axioms of lower generality. Such a mode of procedure may be called *anticipatio naturæ* (for in it reason is allowed to prescribe to things), and is opposed to the true method, the *interpretatio naturæ*, in which reason follows and obeys nature, discovering her secrets by obedience and submission to rule. Lastly, the very form of induction that has been used by logicians in the collection of their instances is a weak and useless thing. It is a mere enumeration of a few known facts, makes no use of exclusions or rejections, concludes precariously, and is always liable to be overthrown by a negative instance.<sup>2</sup> In radical opposition to this method the Baconian induction begins by supplying helps and guides to the senses, whose unassisted information could not be relied on. Notions were formed carefully, and not till after a certain process of induction was completed.<sup>3</sup> The formation of axioms was to be carried on by a gradually ascending scale. "Then and only then may we hope well of the sciences, when in a just scale of ascent and by successive steps, not interrupted or broken, we rise from particulars to lesser axioms; and then to middle axioms, one above the other; and last of all to the most general."<sup>4</sup> Finally the very form of induction itself must be new. "The induction which is to be available for the discovery and demonstration of sciences and arts must analyse nature by proper rejections and exclusions; and then, after a sufficient number of negatives, come to a conclusion on the affirmative instances, which has not yet been done, or even attempted, save only by Plato.<sup>5</sup> . . . And this induction must be used not only to

discover axioms, but also in the formation of notions."<sup>6</sup> This view of the function of exclusion is closely connected with Bacon's doctrine of forms, and is in fact dependent upon that theory. But induction is neither the whole of the new method, nor is it applicable to forms only. There are two other grand objects of inquiry: the one, the transformation of concrete bodies; the other, the investigation of the latent powers and the latent schematism or configuration. With regard to the first, in ultimate result it depends upon the theory of forms; for whenever the compound body can be regarded as the sum of certain simple natures, then our knowledge of the forms of these natures gives us the power of superinducing a new nature on the concrete body. As regards the latent process which goes on in all cases of generation and continuous development or motion, we examine carefully, and by quantitative measurements, the gradual growth and change from the first elements to the completed thing. The same kind of investigation may be extended to many cases of natural motion, such as voluntary action or nutrition; and though inquiry is here directed towards concrete bodies, and does not therefore penetrate so deeply into reality as in research for forms, yet great results may be looked for with more confidence. It is to be regretted that Bacon did not complete this portion of his work, in which for the first time he approaches modern conceptions of change. The latent configuration or inward structure of the parts of a body must be known before we can hope to superinduce a new nature upon it. This can only be discovered by analysis, which will disclose the ultimate constituents (natural particles, not atoms) of bodies, and lead back the discussion to forms or simple natures, whereby alone can true light be thrown on these obscure questions. Thus, in all cases, scientific explanation depends upon knowledge of forms; all phenomena or secondary qualities are accounted for by being referred to the primary qualities of matter.

The several steps in the inductive investigation of the form of any nature flow readily from the definition of the form itself. For that is always and necessarily present when the nature is present, absent when it is absent, decreases and increases according as the nature decreases and increases. It is therefore requisite for the inquiry to have before us instances in which the nature is present. The list of these is called the table of *Essence and Presence*. Secondly, we must have instances in which the nature is absent; only as such cases might be infinite, attention should be limited to such of them as are most akin to the instances of presence.<sup>7</sup> The list in this case is called table of *Absence in Proximity*. Thirdly, we must have a number of instances in which the nature is present in different degrees, either increasing or decreasing in the same subject, or variously present in different subjects. This is the table of *Degrees* or of *Comparison*. After the formation of these tables, we proceed to apply what is perhaps the most valuable part of the

<sup>1</sup> *Prof. to Inst.*

<sup>2</sup> Bacon's summary is valuable. "In the whole of the process which leads from the senses and objects to axioms and conclusions, the demonstrations which we use are deceptive and incompetent. The process consists of four parts, and has as many faults. In the first place, the impressions of the sense itself are faulty, for the sense both fails us and deceives us. But its shortcomings are to be supplied and its deceptions to be corrected. Secondly, notions are all drawn from the impressions of the senses, and are indefinite and confused, whereas they should be definite and distinctly bounded. Thirdly, the induction is such which infers the principles of sciences by simple enumeration, and does not, as it ought, employ exclusions and solutions (or separations) of nature. Lastly, that method of discovery and proof according to which the most general principles are first established, and then intermediate axioms are tried and proved by them, is the parent of error and the cause of all science."—(*N. O.*, l. 69.)

<sup>3</sup> *N. O.*, l. 106. <sup>4</sup> *Ibid.*, l. 104; cf. l. 19-26.

<sup>5</sup> This extract gives an answer to the objection sometimes raised that Bacon is not original in his theory of induction. He certainly admits

that Plato has used a method somewhat akin to his own; but it has frequently been contended that his induction is nothing more than the *ἐπιγνώμη* of Aristotle (see Renaus's *Bacon*, *de.*, pp. 310-315, and for a criticism, Waddington, *Essai de Logique*, p. 261, *seq.*). This seems a mistake. Bacon did not understand by induction the argument from particulars to a general proposition; he looked upon the exclusion and rejection, or upon *elimination*, as the essence of induction. To this process he was led by his doctrine of forms, of which it is the necessary consequence; it is the infallible result of his view of science and its problem, and is as original as that is. Whoever accepts Bacon's doctrine of cause must accept at the same time his theory of the way in which the cause may be sifted out from among the phenomena. It is evident that the Socratic search for the essence by an analysis of instances—an induction ending in a definition—has a strong resemblance to the Baconian inductive method.

<sup>6</sup> *N. O.*, l. 105.

<sup>7</sup> That is to say, differing in nothing save the absence of the nature under investigation.

Baconian method, and that in which the author took most pride, the process of exclusion or rejection. This elimination of the non-essential, grounded on the fundamental propositions with regard to forms, is the most important of Bacon's contributions to the logic of induction, and that in which, as he repeatedly says, his method differs from all previous philosophies. It is evident that if the tables were complete, and our notions of the respective phenomena clear, the process of exclusion would be a merely mechanical counting out, and would infallibly lead to the detection of the cause or form. But it is just as evident that these conditions can never be adequately fulfilled. Bacon saw that his method was impracticable (though he seems to have thought the difficulties not insuperable), and therefore set to work to devise new helps, *adminicula*. These he enumerates in ii., Aph. 21:—*Prerogative Instances, Supports of Induction, Rectification of Induction, Varying the Investigation according to the Nature of the Subject, Prerogative Natures, Limits of Investigation, Application to Practice, Preparations for Investigation, the Ascending and Descending Scales of Axioms*. The remainder of the *Organum* is devoted to a consideration of the twenty-seven classes of Prerogative Instances, and, though it contains much that is both luminous and helpful, it adds little to our knowledge of what constitutes the Baconian method. On the other hands we have but a few scattered hints. But although the rigorous requirements of science could only be fulfilled by the employment of all these means, yet in their absence it was permissible to draw from the tables and the exclusion an hypothetical conclusion, the truth of which might be verified by the use of the other processes; such an hypothesis is called fantastically the First Vintage (*Vindemiatio*). The inductive method, so far as exhibited in the *Organum*, is exemplified by an investigation into the nature of heat.

Such was the method devised by Bacon, and to which he ascribed the qualities of absolute certainty and mechanical simplicity. But even supposing that this method were accurate and completely unfolded, it is evident that it could only be made applicable and produce fruit when the phenomena of the universe have been very completely tabulated and arranged. In this demand for a complete natural history, Bacon also felt that he was original, and he was deeply impressed with the necessity for it;<sup>1</sup> in fact, he seems occasionally to place an even higher value upon it than upon his *Organum*. Thus, in the preface to his series of works forming the third part of the *Instauratio*, he says: "It comes, therefore, to this, that my *Organum*, even if it were completed, would not without the *Natural History* much advance the *Instauration of the Sciences*, whereas the *Natural History* without the *Organum* would advance it not a little."<sup>2</sup> But a complete natural history is evidently a thing impossible, and in fact a history can only be collected by attending to the requirements of the *Organum*. This was seen by Bacon, and what may be regarded as his final opinion on the question is given in the important letter to Baranzano:—"With regard to the multitude of instances by which men may be deterred from the attempt, here is my answer. First, what need to dissemble? Either store of instances must be procured, or the business must be given up. All other ways, however enticing, are impassable. Secondly, the prerogatives of instances, and the mode of experimenting upon experiments of light (which I shall hereafter explain), will diminish the multitude of them very much. Thirdly, what matter, I ask, if the description of the instances should fill six times as many volumes as Pliny's *History*? . . . For the true

natural history is to take nothing except instances, connections, observations, and canons."<sup>3</sup> The *Organum* and the *History* are thus correlative, and form the two equally necessary sides of a true philosophy; by their union the new philosophy is produced.

Two questions may be put to any doctrine which professes to effect a radical change in philosophy or science. Is it original? Is it valuable? With regard to the first, it has been already pointed out that Bacon's induction or inductive method is distinctly his own, though it cannot and need not be maintained that the general spirit of his philosophy was entirely new.

The value of the method is a separate and more difficult question. It has been assailed on the most opposite grounds. Macaulay, while admitting the accuracy of the process, denied its efficiency, on the ground that an operation performed naturally was not rendered more easy or efficacious by being subjected to analysis.<sup>4</sup> This objection is curious when confronted with Bacon's reiterated assertion that the natural method pursued by the unassisted human reason is distinctly opposed to his; and it is besides an argument that tells so strongly against many sciences, as to be comparatively worthless when applied to any one. There are, however, more formidable objections against the method. It has been pointed out,<sup>5</sup> and with perfect justice, that science in its progress has not followed the Baconian method; that no one discovery can be pointed to which can be definitely ascribed to the use of his rules, and that men the most celebrated for their scientific acquirements, while paying homage to the name of Bacon, practically set at naught his most cherished precepts. The reason of this is not far to seek, and has been pointed out by logicians of the most diametrically opposed schools. The mechanical character both of the natural history and of the logical method applied to it, resulted necessarily from Bacon's radically false conception of the nature of cause and of the causal relation. The whole logical or scientific problem is treated as if it were one of co-existence, to which in truth the method of exclusion is scarcely applicable, and the assumption is constantly made that each phenomenon has one and only one cause.<sup>6</sup> The inductive formation of axioms by a gradually ascending scale is a route which no science has ever followed, and by which no science could ever make progress. The true scientific procedure is by hypothesis followed up and tested by verification; the most powerful instrument is the deductive method, which Bacon can hardly be said to have recognised. The power of framing

<sup>1</sup> *Letters and Life*, vii. 377.

<sup>2</sup> Compare what Bacon says, *N. O.*, i. 130.

<sup>3</sup> Brewster, *Life of Newton*, 1855 (see particularly vol. ii. 403, 405); Lasson, *Ueber Bacon von Verulam's wissenschaftliche Principien*, 1860; Liebig, *Ueber Francis Bacon von Verulam*, &c., 1863 (a translation of the last appeared in *Macmillan's Magazine* for July and August 1863). Although Liebig points out how little science proceeds according to Bacon's rules, yet his other criticisms seem of extremely little value. In a very offensive and quite unjustifiable tone, which is severely commented on by Sigwart and Fischer, he attacks the Baconian methods and its results. These results he claims to find in the *Sylva Sylvarum*, entirely ignoring what Bacon himself has said of the nature of that work (*N. O.*, i. 117; cf. Rawley's *Pref. to the S. S.*), and thus putting a false interpretation on the experiments there noted. It is not surprising that he should detect many flaws, but he never fails to exaggerate an error, and seems sometimes completely to miss the point of what Bacon says. (See particularly his remarks on *S. S.*, 33, 336.) The method he explains in such a way as to show he has not a glimpse of its true nature. He brings against Bacon, of all men, the accusations of making induction start from the undetermined perceptions of the senses, of using imagination, and of putting a quite arbitrary interpretation on phenomena. He crowns his criticism by expounding what he considers to be the true scientific method, which, as has been pointed out by Fischer, is simply that Baconian doctrine against which his attack ought to have been directed. (See his account of the method, *Ueber Bacon*, 47-49; K. Fischer, *Bacon*, p. 490-507.)

<sup>4</sup> Mill, *Logic*, ii. pp. 115, 116, 329, 330.

<sup>1</sup> *Dist. Op. (Works*, iv. 28); *Parascorv (ibid.*, 251, 252, 255-256); *De Corp. Glob. Intel.*, ch. 3.

<sup>2</sup> *Works*, ii. 16; cf. *N. O.*, i. 130.

hypotheses points to another want in the Baconian doctrine. If that power form part of the true method, then the mind is not wholly passive or recipient; it anticipates nature, and moulds the experience received by it in accordance with its own constructive ideas or conceptions; and yet further, the minds of various investigators can never be reduced to the same dead mechanical level.<sup>2</sup> There will still be room for the scientific use of the imagination, and for the creative flashes of genius.<sup>3</sup>

If, then, Bacon himself made no contributions to science, if no discovery can be shown to be due to the use of his rules, if his method be logically defective, and the problem to which it was applied one from its nature incapable of adequate solution, it may not unreasonably be asked, How has he come to be looked upon as the great leader in the reformation of modern science? How is it that he shares with Descartes the honour of inaugurating modern philosophy? To this the true answer seems to be, that Bacon owes his position not only to the general spirit of his philosophy, but to the manner in which he worked into a connected system the new mode of thinking, and to the incomparable power and eloquence with which he expounded and enforced it. Like all epoch-making works, the *Novum Organum* gave expression to ideas which were already beginning to be in the air. The time was ripe for a great change; scholasticism, long decaying, had begun

to fall; the authority not only of school doctrines but, of the church had been discarded; while here and there a few devoted experimenters were turning with fresh zeal to the unwithered face of nature. The fruitful thoughts which lay under and gave rise to these scattered efforts of the human mind, were gathered up into unity, and reduced to system in the new philosophy of Bacon.<sup>4</sup> It is assuredly little matter for wonder that this philosophy should contain much that is now inapplicable, and that in many respects it should be vitiated by radical errors. The details of the logical method on which its author laid the greatest stress have not been found of practical service;<sup>5</sup> yet the fundamental ideas on which the theory rested, the need for rejecting rash generalisation, and the necessity for a critical analysis of experience, are as true and valuable now as they were then. Progress in scientific discovery is made mainly, if not solely, by the employment of hypothesis, and for that no code of rules can be laid down such as Bacon had devised. Yet the framing of hypothesis is no mere random guess work; it is not left to the imagination alone, but to the *scientific imagination*. There is required in the process not merely a preliminary critical induction, but a subsequent experimental comparison, verification, or proof, the canons of which can be laid down with precision. To formulate and show grounds for these laws is to construct a philosophy of induction, and it must not be forgotten that the first step towards the accomplishment of the task was made by Bacon, when he introduced and gave due prominence to the powerful logical instrument of exclusion or elimination.

Of the general characteristics of Bacon's philosophy, and of the consequent place he holds in the history of modern speculative thought, this is not the place to speak. It is curious and significant that in the domain of the moral and metaphysical sciences his influence has been perhaps more powerful, and his authority has been more frequently appealed to, than in that of the physical. This is due, not so much to his expressed opinion that the inductive method was applicable to all the sciences,<sup>6</sup> as to the generally practical, or, one may say, *positive* spirit of his system. Theological questions, which had tortured the minds of generations, are by him relegated from the province of reason to that of faith. Even reason must be restrained from striving after ultimate truth; it is one of the errors of the human intellect that it will not rest in general principles, but must push its investigations deeper. Experience and observation are the only remedies against prejudice and error. Into questions of metaphysics as commonly understood Bacon can hardly be said to have entered, but a long line of thinkers have drawn inspiration from him, and it is not without justice that he has been looked upon as the originator and guiding spirit of that empirical school which numbers among its adherents such names as Hobbes, Locke, Hume, Hartley, Mill, Condillac, the Encyclopedists, and many others of smaller note.

In concluding this article, the writer desires to express his obligations to Mr James Spedding for various observations and suggestions made upon it before it went to press, and for the use of certain MS. notes relating to disputable passages in Bacon's life.

*Biography.*—Spedding, *Letters and Life of Lord Bacon*, 7 vols. 1862-74; Macaulay, *Essays*; Campbell, *Lives of Chancellors*; Montagu, *Works*, vol. xvi. and xvii., 1834; Hepworth Dixon, *Personal History of Lord Bacon*, 1861, and *Story of Lord Bacon's Life*, 1862.

*Works.*—The classical edition is that by Messrs R. L. Ellis, J. Spedding, and D. D. Heath, 2d ed., 7 vols., 1870 (i.-iii. contains Philosophical Works; iv. v., Translations; vi. vii., Literary and Professional Works). Montagu's edition (17 vols., 1828-34)

<sup>2</sup> See the vigorous passage in Harnack, *Discourses on the Study of Natural Philosophy*, § 105; cf. § 96 of the same work.

<sup>3</sup> Bacon himself seems to anticipate that the progress of science would of itself render his method antiquated (*Nov. Org.*, i. 130).

<sup>4</sup> *Nov. Org.*, i. 127.

<sup>1</sup> Whewell, *Phil. of Ind. Sc.*, II. 398, 402-3; Ellis, *Int. to Bacon's Works*, I. 39, 61; Brewster, *Newton*, II. 404; Jevons, *Princ. of Science*, II. 320. A severe judgment on Bacon's method is given in Dühring's able but one-sided *Kritische Gesch. d. Phil.*, in which the merits of Roger Bacon are brought prominently forward.

<sup>2</sup> Although it must be admitted that the Baconian method is fairly open to the above-mentioned objections, it is curious and significant that Bacon was not thoroughly ignorant of them, but with deliberate consciousness preferred his own method. We do not think, indeed, that the notions of which he speaks in any way correspond to what Whewell and Ellis would call "conceptions or ideas furnished by the mind of the thinker;" nor do we imagine that Bacon would have admitted these as necessary elements in the inductive process. But he was certainly not ignorant of what may be called a deductive method, and of a kind of hypothesis. This is clear from the use he makes of the *Vindemiatio*, from certain hints as to the testing of axioms, from his admission of the syllogism into physical reasoning, and from what he calls *Experientia Literata*. The function of the *Vindemiatio* has been already pointed out; with regard to axioms, he says (*N. O.*, I. 106), "In establishing axioms by this kind of induction, we must also examine and try whether the axiom so established be framed to the measure of these particulars from which it is derived, or whether it be larger or wider. And if it be larger and wider, we must observe whether, by indicating to us new particulars, it confirm that wideness and largeness as by a collateral security, that we may not either stick fast in things already known, or loosely grasp at shadows and abstract forms, not at things solid and realised in matter." (Cf. also the passage from *Valerius Terminus*, quoted in Ellis's note on the above aphorism.) Of the syllogism he says, "I do not propose to give up the syllogism altogether. S. is incompetent for the principal things rather than useless for the generality. In the mathematics there is to reason why it should not be employed. It is the flux of matter and the inconstancy of the physical body which requires induction, that thereby it may be fixed as it were, and allow the formation of notions well defined. In physics you wisely note, and therein I agree with you, that after the notions of the first class and the axioms concerning them have been by induction well made out and defined, syllogism may be applied safely; only it must be restrained from leaping at once to the most general notions, and progress must be made through a fit succession of steps."—"Letter to Baranzano," *Letters and Life*, vii. 377.) And with this may be compared what he says of mathematics (*Nov. Org.*, II. 8; *Parasceve*, vii.) In his account of *Experientia Literata* (*De Aug.*, v. 2) he comes very near to the modern mode of experimental research. It is, he says, the procedure from one experiment to another, and is not a science, but an art or learned sagacity (resembling in this Aristotle's *ἄγχινοια*), which may, however, be enlightened by the precepts of the *Interpretatio*. Eight varieties of such experiments are enumerated, and a comparison is drawn between this and the inductive method; "though the rational method of inquiry by the Organon promises far greater things in the end, yet this sagacity, proceeding by learned experience, will in the meantime present mankind with a number of inventions which lie near at hand." (*Cf. N. O.*, I. 103.)

is full, but badly arranged and edited. Of numerous editions of individual works, or portions of the whole, the following are good:—*Œuvres Philosophiques de Bacon*, par Bouillet, 3 vols., 1834; *Bacona*, by Whately, 6th ed., 1866, and by W. A. Wright, 1862; *Novum Organum*, by Kitohin (1855); Translation by the same (1855); *Advancement of Learning*, by W. A. Wright.

*Philosophy*.—Besides the Introductions in Ellis and Spedding's edition, the following may be noticed:—Kuno Fischer, *Frans*

*Bacon und seine Nachfolger*, 2d ed., 1875 (1st ed., 1856, trans. into English by Oxenford, 1857); Râmusat, *Bacon, sa vie, ses*, 1857 (2d ed., 1858); Craik, *Bacon's Writings and his Philosophy*, 3 vols. 1844-7 (new ed., 1860); A. Dornar, *De Baconis Philosophia*, Berlin, 1867; Liebig, *Ueber Francis Bacon von Verulam und die Methode der Naturforschung*, 1848; Lanson, *Ueber Bacon von Verulam's wissenschaftliche Principien*, 1860; Bühmer, *Ueber F. Bacon von Verulam*, 1864. (R. AD.)

BACON, JOHN, who may be considered the founder of the British school of sculpture, was born Nov. 24, 1740. He was the son of Thomas Bacon, cloth-worker in South-wark, whose forefathers possessed a considerable estate in Somersethire. At the age of fourteen he was bound apprentice in Mr Crispe's manufactory of porcelain at Lambeth, where he was at first employed in painting the small ornamental pieces of china, but by his great skill in moulding he soon attained the distinction of being meddler to the work. The produce of his labour he devoted to the support of his parents, then in somewhat straitened circumstances. While engaged in the porcelain works he had an opportunity of seeing the models executed by different sculptors of eminence, which were sent to be burned at an adjoining pottery. An observation of these productions appears to have immediately determined the direction of his genius; he devoted himself to the imitation of them with so much success, that in 1758 a small figure sent by him to the Society for the Encouragement of Arts received a prize, and the highest premiums given by that society were adjudged to him nine times between the years 1763 and 1776. During his apprenticeship he also improved the method of working statues in artificial stone, an art which he afterwards carried to perfection. Bacon first attempted working in marble about the year 1763, and, during the course of his early efforts in this art, was led to improve the method of transferring the form of the model to the marble (technically called *getting out the points*), by the invention of a more perfect instrument for the purpose, which has since been adopted by many sculptors both in this and other countries. This instrument possesses many advantages above those formerly employed; it is more exact, takes a correct measurement in every direction, is contained in a small compass, and can be used upon either the model or the marble. In the year 1769 he was adjudged the first gold medal given by the Royal Academy, and in 1770 was made an associate of that body. He shortly afterwards exhibited a figure of *Mars*, which gained him considerable reputation, and he was then engaged to execute a bust of George III., intended for Christ Church, Oxford. He secured the king's favour, and retained it throughout life. His great celebrity now procured him numerous commissions, and it is said, that of sixteen different competitions in which he was engaged with other artists, he was unsuccessful in one case only. Considerable jealousy was entertained against him by other sculptors, and he was commonly charged with ignorance of classic style. This charge he repelled by the execution of a noble head of Jupiter Tonans, and many of his emblematical figures are in perfect classical taste. On the 4th of August 1799, he was suddenly attacked with inflammation, which occasioned his death in little more than two days, in the 59th year of his age. He left a widow, his second wife, and a family of six sons and three daughters. Of his merit as a sculptor, the universal reputation of his works affords decisive proof, and his various productions which adorn St Paul's Cathedral, London, Christ Church and Pembroke College, Oxford, the Abbey Church, Bath, and Bristol Cathedral, give ample testimony to his powers. Perhaps his best works are to

be found among the monuments in Westminster Abbey. (See *Memoir of the late John Bacon, R.A.*, by the Rev. Richard Cecil: London, 1811.)

BACON, SIR NICHOLAS, lord keeper of the great seal in the reign of Queen Elizabeth, was born at Chialhurst in Kent in 1510, and educated at the university of Cambridge, after which he travelled in France, and made some stay at Paris. On his return he settled in Gray's Inn, and applied himself with such assiduity to the study of the law, that he quickly distinguished himself; and, on the dissolution of the monastery of St Edmund's Bury in Suffolk, he obtained a grant of several manors from King Henry VIII., then in the thirty-sixth year of his reign. Two years later he was promoted to the office of attorney in the court of wards, which was a place of both honour and profit. In this office he was continued by King Edward VI.; and in 1552 he was elected treasurer of Gray's Inn. His great moderation and prudence preserved him through the dangerous reign of Queen Mary. Very early in the reign of Elizabeth he was knighted; and in 1558 he succeeded Nicholas Heath, archbishop of York, as keeper of the great seal of England; he was at the same time made one of the queen's privy council. As a statesman, he was remarkable for the clearness of his views and the wisdom of his counsels, and he had a considerable share in the settling of ecclesiastical questions. That he was not unduly elated by his preferments, appears from the answer he gave to Queen Elizabeth when she told him his house at Redgrave was too little for him, "Not so, madam," returned he, "but your majesty has made me too great for my house." On only one occasion did he partially lose the queen's favour. He was suspected of having assisted Hales, the clerk of the hanaper, in his book on the succession, written at the time of Lady Catherine Grey's unjust imprisonment. Bacon was deprived of his seat at the council, and it was even contemplated to deprive him of the seal also. He seems, however, to have quickly regained his position, and to have stood as high in the royal favour as before. He died on the 26th of February 1579, having held the great seal more than twenty years, and was buried in St Paul's, London, where a monument, destroyed by the great fire of London in 1666, was erected to his memory. Granger observes that he was the first lord keeper who ranked as lord chancellor; and that he had much of that penetrating genius, solidity, judgment, persuasive eloquence, and comprehensive knowledge of law and equity, which afterwards shone forth with such splendour in his illustrious son.

BACON, ROGER. The 13th century, an age peculiarly rich in great men, produced few, if any, who can take higher rank than Roger Bacon. He is in every way worthy to be placed beside such thinkers as Albertus Magnus, Bonaventura, and Thomas Aquinas. These had an infinitely wider renown in their day, while he was ignored by his contemporaries and neglected by his successors; but modern criticism has restored the balance in his favour, and is even in danger of going equally far in the opposite direction. Bacon, it is now said, was not appreciated by his age because he was so completely in advance of it; he is a 16th or 17th century philosopher, whose lot has been by some accident cast in the 13th century; he

is no schoolman, but a modern thinker, whose conceptions of science are more just and clear than are even those of his more celebrated namesake.<sup>1</sup> In this view there is certainly a considerable share of truth, but it is much exaggerated. As a general rule, no man can be completely discovered from his national antecedents and surroundings, and Bacon is not an exception. Those who take up such an extreme position regarding his merits have known too little of the state of contemporary science, and have limited their comparison to the works of the scholastic theologians. We never find in Bacon himself any consciousness of originality; he has no fresh creative thought or method to introduce whereby the face of science may be changed; he is rather a keen and systematic thinker, who is working in a well-beaten track, from which his contemporaries were being drawn by the superior attractions of theology and metaphysics.

Roger Bacon was born in 1214, near Ilchester, in Somersetshire. His family appears to have been in good circumstances, for he speaks of his brother as wealthy, and he himself expended considerable sums on books and instruments; but in the stormy reign of Henry III. they suffered severely, their property was spoiled, and several members of the family were driven into exile. Roger completed his studies at Oxford, though not, as current traditions assert, at Merton or at Brazenose, neither of those colleges having then been founded. His great abilities were speedily recognised by his contemporaries, and he came to be on terms of close intimacy with some of the most independent thinkers of the time. Of these the most prominent were Adam de Marisco and Robert Grosseteste (*Capito*), afterwards bishop of Lincoln, a man of liberal mind and wide attainments, who had especially devoted himself to mathematics and experimental science.

Very little is known of Bacon's life at Oxford; it is said he took orders in 1233, and this is not improbable. In the following year, or perhaps later, he crossed over to France, and studied for a considerable length of time at the university of Paris, then the centre of intellectual life in Europe. The years Bacon spent there were unusually stirring. The two great orders, the Franciscans and Dominicans, were in the vigour of youth, and had already begun to take the lead in theological discussion. Alexander of Hales, the author of the great *Summa*, was the oracle of the Franciscans, while the rival order rejoiced in Albertus Magnus, and in the rising genius of the angelic doctor, Thomas Aquinas.

The scientific training which Bacon had received, partly by instruction, but more from the study of the Arab writers, made patent to his eyes the manifold defects in the imposing systems reared by these doctors. It disgusted him to hear from all around him that philosophy was now at length complete, that it had been reduced into compact order, and was being set forth by a certain professor at Paris. Even the great authority on which they reposed, Aristotle, was known but in part, and that part was rendered well-nigh unintelligible through the vileness of the translations; yet not one of those professors would learn Greek so that they might arrive at a real knowledge of their philosopher. The Scriptures, if read at all in the schools, were read in the erroneous versions; and even these were being deserted for the *Sentences* of Peter Lombard. Physical science, if there was anything deserving that name, was cultivated, not by experiment in the true Aristotelian way, but by discussion and by arguments deduced from premises resting on authority or custom. Everywhere there was a show of knowledge covering and concealing fundamental ignorance. Bacon, accordingly, who knew what true science was, and who had glimpses of a scientific *organon* or method, withdrew from the usual

scholastic routine, and devoted himself to languages and experimental researches. Among all the instructors with whom he came in contact in Paris, only one gained his esteem and respect; this was an unknown individual, Petrus de Maharncuria Picardus, or of Picardy, probably identical with a certain mathematician, Petrus Peregrinus of Picardy, who is perhaps the author of a MS. treatise, *De Magnete*, contained in the Bibliothèque Impériale at Paris. The contrast between the obscurity of such a man and the fame enjoyed by the fluent young doctors of the schools seems to have roused Bacon's indignation. In the *Opus Minus* and *Opus Tertium* he pours forth a violent tirade against Alexander of Hales, and against another professor, not mentioned by name, but spoken of as alive, and blamed even more severely than Alexander. This anonymous writer, he says, who entered the order when young (*puerulus*), who had received no proper or systematic instruction in science or philosophy, for he was the first in his order to teach such subjects, acquired his learning by teaching others, and adopted a dogmatic tone, which has caused him to be received at Paris with applause as the equal of Aristotle, Avicenna, or Averroes. He has corrupted philosophy more than any other; he knows nothing of optics or perspective, and yet has presumed to write *de naturalibus*; he is ignorant of speculative alchemy, which treats of the origin and generation of things; he, indeed, is a man of infinite industry, who has read and observed much, but all his study is wasted because he is ignorant of the true foundation and method of science.<sup>2</sup>

It is probable that Bacon, during his stay in Paris, acquired considerable renown. He took the degree of doctor of theology, and seems to have received from his contemporaries the complimentary title of *doctor mirabilis*. In 1250 he was again at Oxford, and probably about this time, though the exact date cannot be fixed, he entered the Franciscan order. His fame spread very rapidly at Oxford, though it was mingled with suspicions of his dealings in magic and the black arts, and with some doubts of his orthodoxy. About 1257, Bonaventura, general of the order, interdicted his lectures at Oxford, and commanded him to leave that town and place himself under the superintendence of the body at Paris. Here for ten years he remained under constant supervision, suffering great privations, and strictly prohibited from writing anything which might be published. But during the time he had been at Oxford his fame had reached the ears of the Papal legate in England, Guy de Foulques, a man of culture and scientific tastes, who in 1265 was raised to the papal chair as Clement IV. In the following year he wrote to Bacon, who had been already in communication with him, ordering him, notwithstanding

<sup>1</sup> It is difficult to identify this unknown professor. Brewer thinks the reference is to Richard of Cornwall; but the little we know of Richard is not in harmony with what is said here, nor with the terms in which he is elsewhere spoken of by Bacon. Erdmann conjectures Thomas Aquinas, which is extremely improbable, as Thomas was unquestionably not the first of his order to study philosophy. Cousin and Charles think that Albertus Magnus is aimed at, and certainly much of what is said applies with peculiar force to him. But some things do not at all cohere with what is otherwise known of Albert. The unknown is said to have received no regular philosophic training; we know that Albert did. The unknown entered the order when very young; unless the received date of Albert's birth be false, he did not enter till nearly twenty-eight years of age. Albert, too, could not be said with justice to be utterly ignorant of alchemy, and his mechanical inventions are well known. It is worth pointing out that Brewer, in transcribing the passage bearing on this (*Op. Ined.* p. 327), has the words *Præterum puerulus*, which in his marginal note he interprets as applying to the Franciscan order. In this case, of course, Albert could not be the person referred to, as he was a Dominican. But Charles, in his transcription, entirely omits the important word *Præterum*. There are other instances in which Brewer and Charles do not agree, e.g., according to Brewer, Bacon speaks of Thomas and Albert as *pueri duorum ordinum*; according to Charles, he says, *pueri duorum ordinum*; a discrepancy not unimportant.

<sup>2</sup> See Dühring, *Kritische Ges. d. Phil.*, 192, 249 51.

any injunctions from his superiors, to write out and send to him a treatise on the sciences which he had already asked of him when papal legate. Bacon, who in despair of being ever able to communicate his results to the world, had neglected to compose anything, and whose previous writings had been mostly scattered tracts, *capitula quaedam*, took fresh courage from this command of the Pope. Relying on his powerful protection, he set at naught the many obstacles thrown in his way by the jealousy of his superiors and brother friars, and despite the want of funds, instruments, materials for copying, and skilled copyists, completed in about eighteen months three large treatises, the *Opus Majus*, *Opus Minus*, and *Opus Tertium*, which, with some other tracts, were despatched to the Pope by the hands of one Joannes, a young man trained and educated with great care by Bacon himself.

The composition of such extensive works in so short a time is a marvellous feat. We do not know what opinion Clement formed of them, but before his death he seems to have bestirred himself on Bacon's behalf, for in 1268 the latter was released and permitted to return to Oxford. Here he continued his labours in experimental science, and also in the composition of complete treatises. The works sent to Clement he regarded as mere preliminaries, laying down principles which were afterwards to be applied to the several sciences. The first part of an encyclopædic work probably remains to us in the *Compendium Studii Philosophici*, belonging to the year 1271. In this work Bacon makes a vehement attack upon the ignorance and vices of the clergy and monks, and generally upon the insufficiency of the existing studies. In 1278 he underwent the punishment which seems to have then been the natural consequence of outspoken opinions. His books were condemned by Jerome de Ascoli, general of the Franciscans, a gloomy bigot, who afterwards became Pope, and the unfortunate philosopher was thrown into prison, where he remained for fourteen years. During this time, it is said, he wrote the small tract *De Retardandis Senectutis Accidentibus*, but this is merely a tradition. In 1292, as appears from what is probably his latest composition, the *Compendium Studii Theologiae*, he was again at liberty. The exact time of his death cannot be determined; 1294 is probably as accurate a date as can be fixed upon.

*Bacon's Works.*—Leland has said that it is easier to collect the leaves of the Sibyl than the titles of the works written by Roger Bacon: and though the labour has been somewhat lightened by the publications of Brewer and Charles, referred to below, it is no easy matter even now to form an accurate idea of his actual productions. His writings, so far as known to us, may be divided into two classes, those yet in manuscript and those printed. An enormous number of MSS. are known to exist in British and French libraries, and probably all have not yet been discovered. Many are transcripts of works or portions of works already published, and therefore require no notice. Of the others, several are of first-rate value for the comprehension of Bacon's philosophy, and, though extracts from them have been given by Charles, it is clear that till they have found an editor, no representation of his philosophy can be complete.<sup>1</sup>

The works hitherto printed (neglecting reprints) are the following:—(1.) *Speculum Alchimie*, 1541—translated into English, 1597; (2.) *De Mirabili Potestate Artis et*

*Natura*, 1542—English translation, 1659; (3.) *Libellus de Retardandis Senectutis Accidentibus*, 1590—translated as the "Cure of Old Age," 1683; (4.) *Sanioris Medicinæ Magistri D. Rogeri Baconis Anglici de Arte Chymia Scripta*, 1603—a collection of small tracts containing *Excerpta de Libro Avicennæ de Anima*, *Brève Breviarium*, *Verbum Abbreviatum*,<sup>2</sup> *Secretum Secretorum*, *Tractatus Trium Verborum*, and *Speculum Secretorum*; (5.) *Perspectiva*, 1614, which is the fifth part of the *Opus Majus*; (6.) *Specula Mathematica*, which is the fourth part of the same; (7.) *Opus Majus ad Clementem IV.*, edited by Jebb, 1733; (8.) *Opera hæcenus Inedita*, by J. S. Brewer, 1859, containing the *Opus Tertium*, *Opus Minus*, *Compendium Studii Philosophici*, and the *De Secretis Operibus Natura*.

How these works stand related to one another can only be determined by internal evidence, and this is a somewhat hazardous method. The smaller works, which are chiefly on alchemy, are unimportant, and the dates of their composition cannot be ascertained. It is known that before the *Opus Majus* Bacon had already written some tracts, among which an unpublished work, *Computus Naturalium*, on chronology, belongs probably to the year 1263; while, if the dedication of the *De Secretis Operibus* be authentic, that short treatise must have been composed before 1249.

It is, however, with the *Opus Majus* that Bacon's real activity begins. That great work, which has been called by Whewell at once the Encyclopædia and the Organum of the 13th century, requires a much fuller notice than can here be given. As published by Jebb it consists of six parts; there should, however, be a seventh, *De Morali Philosophia*, frequently referred to in the *Opus Tertium*. Part I. (pp. 1–22), which is sometimes designated *De Utilitate Scientiarum*, treats of the four *offendiola*, or causes of error. These are, authority, custom, the opinion of the unskilled many, and the concealment of real ignorance with show or pretence of knowledge. The last error is the most dangerous, and is, in a sense, the cause of all the others. The *offendiola* have sometimes been looked upon as an anticipation of the more celebrated doctrines of *Idola*; the two classifications, however, have little in common. In the summary of this part, contained in the *Opus Tertium*, Bacon shows very clearly his perception of the unity of science, and the necessity of an encyclopædic treatment. "Nam omnes scientiæ sunt annexæ, et mutuis se fovant auxilium, sicut partes ejusdem totius, quarum qualibet opus suum peragit, non solum propter se, sed pro aliis."—(*Op. Ined.*, p. 18.)

Part II. (pp. 23–43) treats of the relation between philosophy and theology. All true wisdom is contained in the Scriptures, at least implicitly; and the true end of philosophy is to rise from the imperfect knowledge of created things to a knowledge of the Creator. Ancient philosophers, who had not the Scriptures, received direct illumination from God, and only thus can the brilliant results attained by them be accounted for.

Part III. (pp. 44–57) treats of the utility of grammar, and the necessity of a true linguistic science for the adequate comprehension either of the Scriptures or of books on philosophy. The necessity of accurate acquaintance with any foreign language, and of obtaining good texts, is a subject Bacon is never weary of descanting upon. He lays down very clearly the requisites of a good translator; he should know thoroughly the language he is translating

<sup>1</sup> The more important MSS. are:—(1.) The extensive work on the fundamental notions of physics, called *Compendium Naturalium*, which is found in the Mazarin Library at Paris, in the British Museum, and in the Bodleian and University College Libraries at Oxford; (2.) On the fundamental notions of mathematics, *De Communibus Mathematicis*, part of which is in the Sloane collection, part in the Bodleian; (3.) *Baconis Physica*, contained among the additional MSS. in the British Museum; (4.) The fragment called *Quinta Pars Compendii Theologiae*,

in the Brit. Mus.; (5.) the *Metaphysica*, in the Biblioth. Impér. at Paris; (6.) The *Compendium Studii Theologiae*, in the Brit. Mus.; (7.) The logical fragments, such as the *Summa Dialecticæ*, in the Bodleian, and the glosses upon Aristotle's physics and metaphysics in the library at Amiens.

<sup>2</sup> At the close of the *Verb. Abbrev.* is a curious note, concluding with the words, "opus Rogerus fuit discipulus fratris Alberti."



from the language into which he is translating, and the subject of which the book treats.

Part IV. (57-255) contains an elaborate treatise on mathematics, "the alphabet of philosophy," and on its importance in science and theology. Bacon shows at great length that all the sciences rest ultimately on mathematics, and progress only when their facts can be subsumed under mathematical principles. This singularly fruitful thought he exemplifies and illustrates by showing how geometry is applied to the action of natural bodies, and demonstrating by geometrical figures certain laws of physical forces. He also shows how his method may be used to determine some curious and long-discussed problems, such as the light of the stars, the ebb and flow of the tide, the motion of the balance. He then proceeds to adduce elaborate and sometimes slightly grotesque reasons tending to prove that mathematical knowledge is essential in theology, and closes this section of his work with two comprehensive sketches of geography and astronomy. That on geography is particularly good, and is interesting as having been read by Columbus, who lighted on it in Petrus de Alliaco's *Imago Mundi*, and was strongly influenced by its reasoning.

Part V. (pp. 256-357) treats of perspective. This was the part of his work on which Bacon most prided himself, and in it, we may add, he seems to owe most to the Arab writers Alkindi and Alhazen. The treatise opens with an able sketch of psychology, founded upon, but in some important respects varying from, Aristotle's *De Anima*. The anatomy of the eye is next described; this is done well and evidently at first hand, though the functions of the parts are not given with complete accuracy. Many other points of physiological optics are touched on, in general erroneously. Bacon then discusses very fully vision in a right line, the laws of reflection and refraction, and the construction of mirrors and lenses. In this part of the work, as in the preceding, his reasoning depends essentially upon his peculiar view of natural agents and their activities. His fundamental physical maxims are matter and force; the latter he calls *virtus, species, imago agentis*, and by numberless other names. Change, or any natural phenomenon, is produced by the impression of a *virtus* or *species* on matter—the result being the thing known. Physical action is, therefore, *impressio*, or transmission of force in lines, and must accordingly be explained geometrically. This view of nature Bacon considered fundamental, and it lies, indeed, at the root of his whole philosophy. To the short notices of it given in the 4th and 5th parts of the *Opus Majus*, he subjoined two, or perhaps three, extended accounts of it. We possess at least one of these in the tract *De Multiplicatione Specierum*, printed as part of the *Opus Majus* by Jebb (pp. 358-444). We cannot do more than refer to Charles for discussions as to how this theory of nature is connected with the metaphysical problems of force and matter, with the logical doctrine of universals, and in general with Bacon's theory of knowledge.

Part VI. (pp. 445-477) treats of experimental science, "*domina omnium scientiarum*." There are two methods of knowledge: the one by argument, the other by experience. Mere argument is never sufficient; it may decide a question, but gives no satisfaction or certainty to the mind, which can only be convinced by immediate inspection or intuition. Now this is what experience gives. But experience is of two sorts, external and internal; the first is that usually called experiment, but it can give no complete knowledge even of corporeal things, much less of spiritual. On the other hand, in inner experience the mind is illuminated by the divine truth, and of this supernatural enlightenment there are seven grades.

Experimental science, which in the *Opus Tertium* (p. 46) is distinguished from the speculative sciences and the

operative arts in a way that forcibly reminds us of Francis Bacon, is said to have three great prerogatives over all other sciences:—(1.) It verifies their conclusions by direct experiment; (2.) It discovers truths which they could never reach; (3.) It investigates the secrets of nature, and opens to us a knowledge of past and future. As an instance of his method, Bacon gives an investigation into the nature and cause of the rainbow, which is really a very fine specimen of inductive research.

The seventh part of the *Opus Majus*, not given in Jebb's edition, is noticed at considerable length in the *Opus Tertium* (esp. xiv.) Extracts from it are given by Charles, (pp. 339-348).

As has been seen, Bacon had no sooner finished this elaborate work than he began to prepare a summary to be sent along with it. Of this summary, or *Opus Minus*, part has come down and is published in Brewer's *Op. Ined.* (313-389), from what appears to be the only MS. The work was intended to contain an abstract of the *Opus Majus*, an account of the principal vices of theology, and treatises on speculative and practical alchemy. At the same time, or immediately after, Bacon began a third work as a preamble to the other two, giving their general scope and aim, but supplementing them in many points. The part of this work, generally called *Opus Tertium*, is printed by Brewer (pp. 1-310), who considers it to be a complete treatise. Charles, however, has given good grounds for supposing that it is merely a preface, and that the work went on to discuss grammar, logic (which Bacon thought of little service, as reasoning was innate), mathematics, general physics, metaphysics, and moral philosophy. He finds his argument mainly on passages in the *Comensura Naturalium*, which indeed prove distinctly that it was sent to Clement, and cannot, therefore, form part of the *Compendium*, as Brewer seems to think. It must be confessed, however, that nothing can well be more confusing than the references in Bacon's works, and it seems well-nigh hopeless to attempt a complete arrangement of them until the texts have been collated and carefully printed.

All these large works Bacon appears to have looked on as preliminaries, introductions, leading to a great work which should embrace the principles of all the sciences. This great work, which is perhaps the frequently referred to *Liber Sex Scientiarum*, he began, and a few fragments still indicate its outline. First appears to have come the treatise now called *Compendium Studii Philosophia* (Brewer, pp. 393-519), containing an account of the causes of error, and then entering at length upon grammar. After that, apparently, logic was to be treated; then, possibly, mathematics and physics; then speculative alchemy and experimental science. It is, however, very difficult, in the present state of our knowledge of the MSS., to hazard even conjectures as to the contents and nature of this last and most comprehensive work.

Bacon's fame in popular estimation has always rested on his mechanical discoveries. Careful research has shown that very little in this department can with accuracy be ascribed to him. He certainly describes a method of constructing a telescope, but not so as to lead one to conclude that he was in possession of that instrument. Gunpowder, the invention of which has been claimed for him on the ground of a passage in his works, which fairly interpreted at once disposes of any such claim, was already known to the Arabs. Burning-glasses were in common use, and spectacles it does not appear he made, although he was probably acquainted with the principle of their construction. His wonderful predictions (in the *De Secretis*) must be taken *cum grano salis*; and it is not to be forgotten that he believed in astrology, in the doctrine of signatures, and in the philosopher's stone, and knew that the circle had been squared.

The best work on Roger Bacon is undoubtedly that of K. Charles, *Roger Bacon, sa Vie, ses Ouvrages, ses Doctrines d'après des textes inédits*, 1861. Against the somewhat enthusiastic estimate and modern interpretation given in this work, Schneider in his *Roger Bacon, Eine Monographie*, Augsburg, 1873, has reclaimed. He points out very clearly certain aspects in which Bacon appears as a mere scholastic. The new matter contained in the publications of Charles and Brewer was summarized by H. Siebert, *Roger Bacon: Inaugural Dissertation*, Marburg, 1861. Cf. also, J. K. Ingram, *On the Opus Majus of Bacon*, Dublin, 1858; Cousin, *Fragments, Phil. du Moyen Age* (reprinted from *Journal des Savants*, 1848); Salusset, *Érécursurs et Disciples de Descartes*, pp. 1-58 (reprinted from *Revue des Deux Mondes*, 1861); Prantl, *Gesch. der Logik*, iii. 120-129 (a severe criticism of Bacon's logical doctrines). (R. AD.)

BACONTHORPE, or BACON, JOHN, called The Resolute Doctor, a learned monk, born towards the end of the 13th century, at Baconthorpe, a village in Norfolk. After spending the early part of his life in the convent of Blakeney, near Walsingham, he removed to Oxford, and from that city to Paris, where he obtained great reputation for his learning, and was esteemed the principal of the Averroists. In 1329 he returned to England, and was chosen twelfth provincial of the English Carmelites. In 1333 he was sent for to Rome, where, we are told, he first maintained the Pope's sovereign authority in cases of divorce; but this opinion he is understood to have afterwards retracted. He died in London in 1346. His chief work was published in 1510, with the title *Doctoris resoluti Joannis Baconis Anglici Carmelita radiantissimi opus super quatuor sententiarum libros*, 4 vols. folio; it has passed through several editions. The little that is known of this schoolman, who in his own day and order had a reputation rivalling that of Thomas Aquinas, may be seen in Bruoker, *Hist. Crit.*, iii. 865; Stöckl, *Phil. d. Mittel.* ii. 1044-5; Hauréau, *Phil. Scol.*, ii. 476; Prantl, *Ges. d. Logik*, iii. 318.

BACSAANYI, JANOS, a Hungarian poet, was born at Tapoleza, May 11, 1763, and died at Linz, May 12, 1845. In 1785 he published his first work, a patriotic poem, *The Valour of the Magyars*. In the same year he obtained a situation as clerk in the treasury at Kaschau, and there, in conjunction with other two Hungarian patriots, edited the *Magyar Museum*, which was suppressed by the Government in 1792. In the following year he was deprived of his clerkship; and in 1794, having taken part in the conspiracy of Bishop Martinovich, he was thrown into the state prison of the Spielberg, near Brünn, where he remained for two years. After his release he took a considerable share in the *Magyar Minerva*, a literary review, and then proceeded to Vienna, where he obtained a post in the bank, and married. In 1809 he translated Napoleon's proclamation to the Magyars, and, in consequence of this anti-Austrian act, had to take refuge in Paris. After the fall of Napoleon he was given up to the Austrians, who allowed him to reside at Linz, on condition of never leaving that town. He published a collection of poems at Pesth, 1827 (second edition, Buda, 1835), and also edited the poetical works of Anyos and Faludi.

BACTRIA, or BACTRIANA, an ancient country of Central Asia, lying to the south of the River Oxus, and reaching to the western part of the Paropamian range, or Hindu Kush. It was sometimes regarded as including the district of Margiana, or Merv, which was more frequently considered as distinct. The character of the country is very various, and has been well described by Curtius, whose account is confirmed by the few modern travellers who have passed through it. Some portions are remarkable for the beauty of their scenery, or the fertility of the soil, evidenced by a rich and varied vegetation, while other parts are stretches of barren and drifting sands. In early history Bactria is connected with some of the most important movements of the Indo-European races, and has no small claims to be regarded as the cradle of our present civilisation. Accord-

ing to Persian tradition, it became the seat of the Iranian wanderers, who established the religion of Zoroaster, and expelled the Vedic inhabitants of the country. In the 7th century B.C. it passed under the dominion of the Medes, and not long after formed part of the conquests of Cyrus. In the reign of Darius it ranked as the twelfth satrapy of the empire, and furnished valuable contingents to the imperial army; these are described at a later date by Herodotus as wearing the Median head-dress, and making use of their native bows and short spears. Like the rest of Western Asia, Bactria was subjugated by Alexander, and formed part of the empire of the Seleucids; but in the 3d century B.C. it was raised to the rank of an independent kingdom by the successful revolt of Diodotus, the Greek satrap. There thus arose a remarkable dynasty—if dynasty it can be called—of Græco-Bactrian kings, who have been the object of much modern investigation, but are not as yet arranged in any satisfactory order. The names of seven or eight of them are known from the Greek and Roman historians, and upwards of forty are preserved on their coins. The great problem to be solved by numismatists is how to dispose of so many claimants in the comparatively narrow space of time at their disposal. It is highly probable that many of them held contemporaneous sway in different parts of the Bactrian region, sometimes with a distinct preponderance on the part of one, and sometimes with practical equilibrium of power; but their geographical distribution can only be conjectured from what are understood to be mint-marks on their coins. The period of the final disintegration of the Græco-Bactrian power is not definitely ascertained; but as early as the time of Eucratides (160 B.C.) there appears on the coinage the so-called Bactrian Pali, a language cognate with Sanskrit but written in characters of seemingly Phœnician origin. Besides these monetary legends, several Bactrian inscriptions have been recently discovered, among the most important of which are the "Taxila" copperplate, which has furnished the key to the Bactrian numeral system, the Peshawur vase, the Manikyala cylinder, the Bimaran vase, and the Wardak urn, but none of them are of very much historical value. Bactria seems to have passed successively under the power of various Saca and Parthian and so-called Indo-Scythian rulers; and during the first six or seven centuries of the Christian era it became one of the most important centres of Buddhist monasticism. (See BALKH.) Its modern history is of but little importance, as it has never formed an independent kingdom of any power or stability.

See Bayer, *Hist. Reg. Græco-Bactr.*, Petrop., 1738; Köhler, *Mit. grieches des Bois de la B.*, St Pet., 1822-3; Tychem, *Comm. Recem. Götting.*, v. vi.; Tod, in *Roy. Asiat. Soc. Trans.*, 1824; Schlegel, in *Journ. Asiat.*, 1828; Prinsep, in *J. of Asiat. Soc. Bengal*, 1833-38; Raoul-Rochette, in *Jour. des Savants*, 1834-39 and 1844; Jaquet, in *J. Asiat.*, 1836; Masson, in *J. of Asiat. Soc. Bengal*, 1836; K. O. Müller, in *Göttingen Anzeiger*, 1836 and 1838; Mionnet, in *Supplément viii. to his Description, &c.*, 1837; Lassen, *Zur Gesch. der Griech. u. Indoskyth. Kön.*, Bonn, 1838; Grotefend, *Die Münzen der Kön. v. Bactr.*, Hanover, 1839; Wilson, *Ariana Antiqua*, 1841; Cunningham, *Numism. Chron.*, viii. 1848; Lassen, *Indische Alterthumskunde*, vol. ii., 1852; Babu Rajendra Lal, in *J. Asiat. Soc. of Bengal*, 1861; E. Thomas, "Bactrian Coins," in *J. Roy. Asiat. Soc. Gr. Brit. and I.*, 1873; Dowson, "B. Pali Inscr.," *ibidem*.

BACUP, a town of England, in Lancashire, 20 miles N. from Manchester. It is situated in a beautiful valley on the River Speddon, and is a station on the East Lancashire railway. It is chiefly important for its factories, foundries, and mills, as well as for the coal-mines in the neighbourhood. Since 1841, when the population of the chapelry was only 1526, Bacup has rapidly increased, and its sanitary condition has been greatly improved by the exertions of a local board. The river has been deepened for a mile above the town, and a water supply has been secured by means of a reservoir at Higher Stacks. There are two Episcopal

churoks and several dissenting places of worship, a mechanics' institute and library, and various other institutions. A new market-hall was built in 1867. Population of local board district in 1871, 17,199.

**BADAJOS**, a province of Spain, forming, by the division of 1833, the southern half of the old province of Estremadura, or what is generally called Lower Estremadura. It is bounded on the N. by Cáceres, E. by Ciudad Real, S. and S.E. by Cordova, Sevilla, and Huelva, and W. by Portugal, embracing an area of 8687 square miles. See **ESTREMADURA**.

**BADAJOS**, the capital of the above province, is a fortified city, and the see of a bishop. It is situated about 5 miles from the Portuguese frontier, on a slight elevation near the left bank of the Guadiana, and is one of the principal stations on the railway between Madrid and Lisbon. The height is crowned by the ruins of a Moorish castle. A strong wall and bastions, with a broad moat and outworks, and forts on the surrounding heights, make the city a place of great strength. The river is crossed by a magnificent granite bridge, originally built in 1460, repaired in 1597, and rebuilt in 1833. The city is well built, and contains an amenal, a cathedral, built like a fortress and bombproof, several churches, hospitals, and schools. Its monasteries are all secularised, one being occupied as infantry barracks; and some of its nurseries are closed. Badajos was finally taken from the Moors in 1235 by Alphonso IX., and from its importance as a frontier garrison has since been the scene of numerous sieges. The last and most severe was in 1812, when it was stormed by the British troops under Wellington and carried with dreadful loss. The town was delivered up to a two days' pillage. It had been surrendered the previous year to Soult by the treachery of Imas, the commander of the garrison. The trade and manufactures of Badajos are considerable, and much contraband traffic is carried on with Portugal. Badajos is the birthplace of the painter Luis de Morales and of Manuel Godoy. Pop. 22,895.

**BADAKHSHAN**, a country of Central Asia, situated in the upper valley of the Kokcha river, one of the principal head streams of the Oxus. The name has been variously spelt Badashian, Balacian, Balakhahan, Balashan, Balaxien and Balaxia. Including Wakhan, it lies between 35° 50' and 38° N. lat., and between 69° 30' and 74° 20' E. long. The chief ascertained positions are as follows: Faizábád, 37° 2' N., 70° 36' E.; Iahkashm, 36° 45' N., 71° 38' E.; Panja, 37° 5' N., 72° 39' E.; and Kerkat Yassin lake, 37° 14' N., 74° 18' E. Its extent from east to west is about 200 miles, and from north to south about 150 miles. On the north it is bounded by Kulab and Darwas; on the east by the lofty table-land of Pamir; on the south by the Hindu Kush range; and on the west by Kunduz. The Pamir land is the principal watershed of Asia, and Badakhshan forms part of the western water slope constituting the basin of the Oxus. The country is for the most part mountainous; but there are numerous plains and fertile valleys. The general slope of the country is great, since Kunduz is probably not more than 500 feet above the level of the sea, while Lake Victoria, close to the principal watershed, is estimated at 15,600 feet.

Badakhshan comprises 16 districts. The principal district called Faizábád is under the rule of the Mir Mahmúd Shah; the others are dependencies ruled by relatives of the Mir, or by hereditary feudatories. Each ruler is independent, but is bound to aid the Mir of Faizábád in time of need. The Mir himself pays tribute to the Amir of Cabul. The other districts besides Faizábád are Darsim, Shahr-i-buzurg, Gumbus, Farakhar, Kishm, Rustak, Rushan, Shighmín, Iahkashm, Wakhán, Zebak, Minján, Ragh, Daung, and Asiáá. Each district has its sub-divisions. In Faizábád there are several fertile tracts; amongst them are the hilly regions of Yaftal and Showá, which are thickly popu-

lated, the former by Tajiks, and the latter by Turks of the Jakha Moghal tribe; and the plateaus of Argú and Showá, of which the former is somewhat higher than the plain of Faizábád, about 15 miles in length by about 8 in breadth, and well cultivated, while the latter is still higher, and forms the best and largest pasture ground in Badakhshan. A lake named Sir-i-kol, about 20 miles in circumference, is situated on the Shewá plateau. In and around Faizábád there are numerous excellent fruit and flower gardens; the principal manufactures are cast-iron pots, boots and shoes, and a material woven from silk and cotton, called *shacha*. The district of Jirm, also subject to Mahmúd Shah, comprises numerous rich valleys, as well as the famous mineral region called Yamgan, or "all mines." The mines yield rubies, lapis lazuli, lead, alum, sal-ammoniac, sulphur, copper, &c. The annual yield of lapis lazuli averages about £1500, which is sold at the rate of seven shillings per pound; it is exported to Russia, Kashmir, and China. The Dasht-Baha-rak is an extensive plain in this district, on which was formerly situated a large city, once the capital of Badakhshan. There are several villages on it, as also the summer residence of the Mir. The caravan route from India to Faizábád passes over this plain. The districts of Rustak, Ragh, Kishm, Darsim, and Shahr-i-buzurg are next in importance as regards fertility and population. They abound in fertile hills and plains. The principal cultivated products are wheat, rice, *Cicer arietinum*, *Phaseolus Mungo*, cotton, linseed, poppy, sesame, apples, grapes, mulberries (which form the principal article of food in these regions), pears, apricots, walnuts, melons, gourds, turnips, radishes, carrots, spinach, leeks, as also numerous garden flowers and timber trees. The districts of Minján and Rushan are more mountainous, have a cooler climate, and are more sparsely populated than the foregoing. Their inhabitants are also distinct, differing in physical features, creed, language, and habits. The celebrated ruby mines are in Iahkashm; they have not been worked for more than 30 years, except temporarily in 1866. It is, however, suspected that they are worked surreptitiously by the people. They yield the well-known Belas (*i.e.*, Badakhshan) ruby.

The principal domesticated animal is the yak. There are also large flocks of sheep, cows, goats, ponies, numerous fine dogs, and Bactrian camels. The more important wild animals are a large wild sheep (*Ovis polii*), foxes, wolves, jackals, bears, boars, deer, and lions; and amongst birds, there are partridges, pheasants, ravens, jays, sparrows, larks, a famous breed of hawks, &c.

Badakhshan proper is peopled by Tajiks, Turks, and Arabs, who speak the Persian and Turki languages, and profess the orthodox doctrines of the Mahometan law adopted by the Sunnite sect; while the mountainous districts are inhabited by Tajiks, professing the Shia creed, and speaking distinct dialects in different districts.

Badakhshan was visited by Hwen Thsang in 630 and 644. The Arabian geographers of the 10th century speak of its mines of ruby and azure, and give notices of the flourishing commerce and large towns of Wakhan and Khotl, regions which appear either to have in part corresponded with or to have lain close to Badakhshan. In 1272-73 Marco Polo and his companions stayed for a time in Badakhshan. During this and the following centuries the country was governed by kings who claimed to be descendants of Alexander the Great. The last of these kings was Shah Mahomet, who died in the middle of the 15th century, leaving only his married daughters to represent the royal line. Early in the middle of the 16th century the Uzbeks obtained possession of Badakhshan, but were soon expelled, and then the country was generally governed by descendants of the old royal dynasty by the female line. About the middle of the 18th century the present dynasty of

Mirs established its footing in place of the old one which had become extinct. In 1765 the country was invaded and ravaged by the ruler of Cabul. During the first three decades of the present century it was overrun and depopulated by Kokan Beg and his son Murad Beg, chiefs of the Kataghan Uzbeks of Kundus. The country was still suffering from these disasters when Wood visited it in 1837. When Murad Beg died, the power passed into the hands of another Uzbek, Mañomet Amir Khan. In 1859 the Kataghan Uzbeks were expelled; and Mir Jahander Shah, the representative of the modern royal line, was reinstated at Faizábád under the supremacy of the Afghans. In 1867 he was expelled by the Afghans and replaced by the present ruler, Mir Mahomet Shah, and other representatives of the same family. According to the latest accounts the country was reviving from its past misfortunes, and the towns were again rising. Badakhshan owes part of its prosperity to the baneful traffic in slaves. A strong man is considered a fair exchange for a large dog or horse, and a fine girl for about four horses. The district is of some political interest in connection with the frontier line of Afghanistan, which has recently been the subject of discussion between the Russian and British Governments.

In 1867 a report on Badakhshan was drawn up by the Fundit Mun-phool after a sojourn of two or three years in the country. For further information, see the *Book of Ser Marco Polo*, vol. i. 1871, edited by Col. Yule; *A Journey to the Sources of the River Oxus*, by Capt. J. Wood, edition of 1872; "Report on the Mirs's Exploration from Cabul to Kashgar," by Major Montgomerie, in the *Journal of Roy. Geo. Soc.*, vol. xli. p. 182; "A Havildar's journey through Chitral to Faizábád in 1870," by Major Montgomerie, in journal last mentioned, vol. xlii. p. 180; "Papers connected with the Upper Oxus Regions," by Col. Yule, in the same volume, p. 438; "Monograph on the Oxus," by Maj.-Gen. Sir H. C. Rawlinson, in the same volume, p. 483; and a paper by the writer last mentioned, "On Badakhshan and Wakhan," in the *Proceedings of the Roy. Geog. Soc.*, vol. xvii. p. 108.

**BADALOCCHIO**, Sisto, surnamed ROSA, a painter and engraver, was born at Parma in 1581, and died in 1641 or 1647. He was of the school of Annibale Carracci, by whom he was highly esteemed for design. His principal engravings are the series known as *The Bible of Raffaele*, which were executed by him in conjunction with Lanfranc, another pupil of Carracci's. The best of his paintings, which are few in number, are at Parma.

**BADEN, THE GRAND DUCHY OF**, is situated in the S.W. of Germany, between 47° 32' and 49° 52' N. lat. and between 7° 27' and 9° 50' E. long. It is bounded on the N. by Bavaria and Hesse-Darmstadt; W. by Rhenish Bavaria, Alsace, and Lorraine; S. by Switzerland; and E. by Würtemberg and part of Bavaria. At the commencement of the present century Baden was only a margraviate, with an area little exceeding 1300 square miles, and a population of 210,000. Since then it has from time to time acquired additional territory, so that its area now amounts to upwards of 5800 square miles, and its population to nearly a million and a half.

It consists of a considerable portion of the eastern half of the fertile valley of the Rhine, and of the mountains which form its boundary. The mountainous part is by far the most extensive, forming, indeed, nearly 80 per cent. of the whole area. From the Lake of Constance in the south to the River Neckar is a portion of the so-called Black Forest or *Schwarzwald*, which is divided by the valley of the Kinzig into two districts of different elevation. To the south of the Kinzig the mean height is 3100 feet, and the loftiest summit, the Feldberg, reaches about 4780 feet; while to the north the mean height is only 2100 feet, and the Belchen, the culminating point of the whole, does not exceed 4480. To the north of the Neckar is the Odenwald range, with a mean of 1440 feet, and, in the Katzenbuckel,

an extreme of 1980. Lying between the Rhine and the Dreisam is the Kaiserstuhl, an independent volcanic group, nearly 10 miles in length and 5 in breadth, the highest point of which is 1760 feet.



Sketch Map of the Grand Duchy of Baden.

The greater part of Baden belongs to the basin of the Rhine, which receives upwards of twenty tributaries from the highlands of the duchy alone; a portion of the territory is also watered by the Main and the Neckar. A part, however, of the eastern slope of the Black Forest belongs to the basin of the Danube, which there takes its rise in a number of mountain streams. Among the numerous lakes which belong to the duchy are the Mummel; Wilder, Nonnenmattweiher, Titti, Eichener, Schluch, &c., but none of them are of any size. The Lake of Constance, or Boden See, belongs partly to Bavaria and Switzerland.

From 1819 to 1832 Baden was divided into six circles, which were reduced in the latter year to the four following:—The Lake Circle or Constance, the Upper Rhine of Freiburg, the Middle Rhine or Karlsruhe, and the Lower Rhine or Mannheim. This division, though still employed, has been legally supplanted by one into the eleven circles of Constance, Villingen, Waldahut, Freiburg, Lörrach, Offenburg, Baden, Karlsruhe, Mannheim, Heidelberg, and Mosbach. The capital of the duchy is Karlsruhe, which in 1871 had a population of 36,582; the other principal towns are Mannheim (39,614), Freiburg (24,599), Heidelberg (19,988), Pforzheim (19,801), Rastadt (11,559), Baden (10,083), Constance (10,052), Bruchsal (9786), and Lahr (6710). The population is most thickly clustered in the north and in the neighbourhood of the Swiss town of Basel.

The mineral wealth of Baden is not very great; but the mines of Oberwert, Kandern, &c., produce excellent iron; there are two zinc mines and one of lead; coal is worked at Diesburg, Zunsweier, Baden, &c.; and silver, copper, gold, cobalt, alum vitriol, and sulphur are also obtained in small quantities. Gold washing, at one time extensively carried on along the Rhine, is now little practised. Peat is found in abundance, as well as gypsum, china-clay, and

potter's earth. The duchy was formerly dependent on France for its salt supply, but extensive salt works have for a number of years been maintained by the Government at Dürnheim and Rappenan. In 1874 the amount produced was of the value of £54,880. The mineral springs of Baden are very numerous, and have acquired great celebrity,—those of Baden-Baden, Badenweiler, Antogast, Griesbach, Frierbach, and Petersthal, being the most frequented.

The inhabitants of Baden are of various origin,—those to the N. of the Murg being descended from the Alemanni, and those to the S. from the Franks, while the Swabian plateau derives its name and its population from another race. This distinction is still marked in the manners, the language, and the dress of the different districts. The majority of the people are engaged in agricultural and pastoral pursuits, for which much of the country is well adapted. In the valleys the soil is particularly fertile, yielding luxuriant crops of wheat, maize, barley, spelt, beans, potatoes, flax, hemp, hops, beet-root, and tobacco; and even in the more mountainous parts rye, wheat, and oats are extensively cultivated. There is a considerable extent of pasture land, and the rearing of cattle, sheep, pigs, and goats is largely attended to. The culture of the vine has recently been increasing, and the wines, which are characterised by a mildness of flavour, are in good demand. The gardens and orchards supply abundance of fruits, especially almonds and walnuts; and the keeping of bees is common throughout the country. A greater proportion of Baden than of any other of the South German states is occupied by forests. In these the predominant species are the fir and pine, but many others, such as the chestnut, are well represented. A third, at least, of the annual supply of timber is exported, the chief consumer being Holland, though of late years Paris has derived a considerable supply from this source.

The manufactures of Baden were formerly very insignificant, but have greatly increased since its accession to the Zollverein in 1835. They are, however, chiefly confined to iron and hardware goods, and the spinning and weaving of cotton. The latter industry is principally carried on at Ettlingen, Offenburg, St Blaise, Zell, Schopfheim; Mannheim has an extensive manufacture of mirrors, and Karlsruhe of machines; while Pforzheim is famous for its production of jewellery and goldsmiths' work. Beet-root sugar is manufactured at Waghäusel more largely than anywhere else in Germany. Paper, leather, and tobacco are also important objects of industry. The inhabitants of the Black Forest have long been celebrated for their dexterity in the manufacture of wooden ornaments and toys, watches, clocks, musical boxes, organs, &c. Of clocks alone about 600,000 are made every year.

The exports of Baden, which coincide largely with the industries just mentioned, are of considerable importance, but the bulk of its trade consists in the transit of goods. The country is well furnished with roads and railways, the greater proportion of the latter being in the hands of the state. A line runs the whole length of the land, for the most part parallel with the Rhine, while branches cross obliquely from east to west.

The educational institutions of Baden are numerous and flourishing, and public instruction is largely subsidised by the Government. There are two universities, the Protestant one at Heidelberg, founded in 1386, and the Catholic one at Freiburg, founded in 1457. The library at Heidelberg numbers 150,000 volumes, and that at Freiburg 100,000, while there is another of almost equal size at Karlsruhe. There are also lycæums at Karlsruhe, Constance, Freiburg, Heidelberg, Mannheim, Rastadt, and Wertheim; several gymnasiums; normal schools at Karlsruhe, Ettlingen, and

Meersburg, besides upwards of 2000 common schools established throughout the country. There is an institution in Pforzheim for the deaf and dumb, and one in Freiburg for the blind. The polytechnic school at Karlsruhe is among the most efficient institutions of the kind in Germany. The preparatory course extends over three years, and includes French, German, English, special history, mathematics, drawing, modelling, chemistry, mineralogy and geology, mechanics, &c. The special courses are engineering, architecture, forestry, chemistry, mechanics, commerce, and post-office service, and extend over from one to four years. The ducal family of Baden belong to the Protestant section of the Church, but the majority of the population are Roman Catholics. The returns of the census of 1871 are as follows:—Catholics, 942,560; Protestants, 491,008; other sects, 2265; and Jews, 25,703. The district where the Roman Catholic preponderance was greatest was Constance, while the Protestants were slightly more numerous in the district of Mannheim.

The government of Baden is an hereditary monarchy, with the executive power vested in the grand duke, and the legislative authority in a Parliament consisting of two Chambers. The upper Chamber is composed of all the princes of the reigning line who are of age, the chiefs of ten noble families, the possessors of hereditary landed estates worth £25,000, the Roman Catholic archbishop of Freiburg, the president of the Protestant Church, a deputy from each of the universities, and eight nominees of the duke. The lower Chamber consists of 63 representatives, of whom 22 are elected by the burgesses of certain towns, and 41 by the inhabitants of the balliwicks. The parliamentary candidate must possess tax-paying property of the value of 10,000 florins (£833), or derive a salary of at least £125 from a public office. Every citizen, if neither criminal nor pauper, has the right of voting, but only in the choice of deputy-electors, by whom the real election of the representatives is decided. The members of the lower House are elected for eight years, and meetings of Parliament must take place every two years.

The budgets are granted by Parliament for a term of two years. In 1875 the ordinary expenses were rated at £1,572,959, and the ordinary receipts at £1,557,108. The total public debt on the 1st of January 1874 was £12,985,067.

Since the organisation of 1864 courts are held at Constance, Freiburg, Offenburg, Karlsruhe, and Mannheim, the supreme court being in the city last named. Mannheim is also the seat of the central commission for the navigation of the Rhine.

The ducal family of Baden traces its descent from the counts of Zähringen, who flourished in the 11th century, and derived their title from what is now a little town to the north of Freiburg. Hermann I., the second son of Count Berthold I., took the title of margrave of Hochberg in Breisgau, and was succeeded in 1074 by his son Hermann II., who was the first to style himself margrave of Baden. On the death of the Margrave Christopher in 1527, his estates were divided among his three sons, but one of them having died soon after, the two survivors became the sole inheritors, and founded the two lines of Baden-Baden and Baden-Durlach. The former of these, which produced one of the most famous generals of the 17th century, became extinct by the death of Augustus George in 1771, and its possessions were united with Baden-Durlach under Charles Frederick. By the treaty of Lunéville in 1801, Baden acquired a considerable addition of territory; in 1803 the margrave received the title of Elector; and by the treaty of Presburg in 1805 his domains were still further increased by the accession of Breisgau. On the dissolution of the empire in 1806, the elector

joined the Confederation of the Rhine, and received the title of Grand Duke, with 1950 square miles of additional territory. Shortly after this extension and consolidation had taken place, Bavaria laid claim to a portion of the duchy, but her demands were indignantly rejected, and in 1818 the grand duke bestowed on the country a political constitution, the fundamental principle of which was the territorial integrity of Baden. In the following year this integrity was guaranteed by the Frankfurt Commission. The first session of the Baden parliament fell into disputes and had to be dissolved; but the second, in 1820, commenced the work of reform by the complete abolition of serfdom and the establishment of ministerial responsibility. In 1821 the union of the two Protestant churches in Baden was brought about. Other questions of importance, such as trial by jury, freedom of the press, abolition of tithes, and extension of education, became subjects of interest and debate; but, unfortunately, the influence of the French revolution of 1830 led the democratic party to excesses, which the Government met with acts of ill-advised repression. Matters were beginning to readjust themselves when the revolution of 1848 again aroused the opposing

forces. In 1849 the duke was constrained to flee, and Brentano, the democratic leader, took possession of Karlsruhe in the name of the national committee. By the 25th of June, however, the Prussian forces, after several severe engagements with the revolutionists, effected the restoration of the duke, who returned to his capital on 18th August; and it was not long before the country began to recover from the effects of the outbreak. Not, indeed, that it became quiescent; for Baden has had its full share in the political and ecclesiastical disputes that have been so rife throughout Germany during recent years. The Roman Catholic clergy, with the bishop of Freiburg at their head, have maintained an obstinate struggle with the Liberal party, which is now predominant. The separation of church and state has been established; the Jews have been admitted to full civic rights; freedom of trade has been promulgated, and a number of minor reforms successfully carried through. In the German war of 1866 Baden sided against Prussia; but in 1870 it joined in the formation of the new German empire, and its troops are incorporated in the 14th corps of the imperial army.

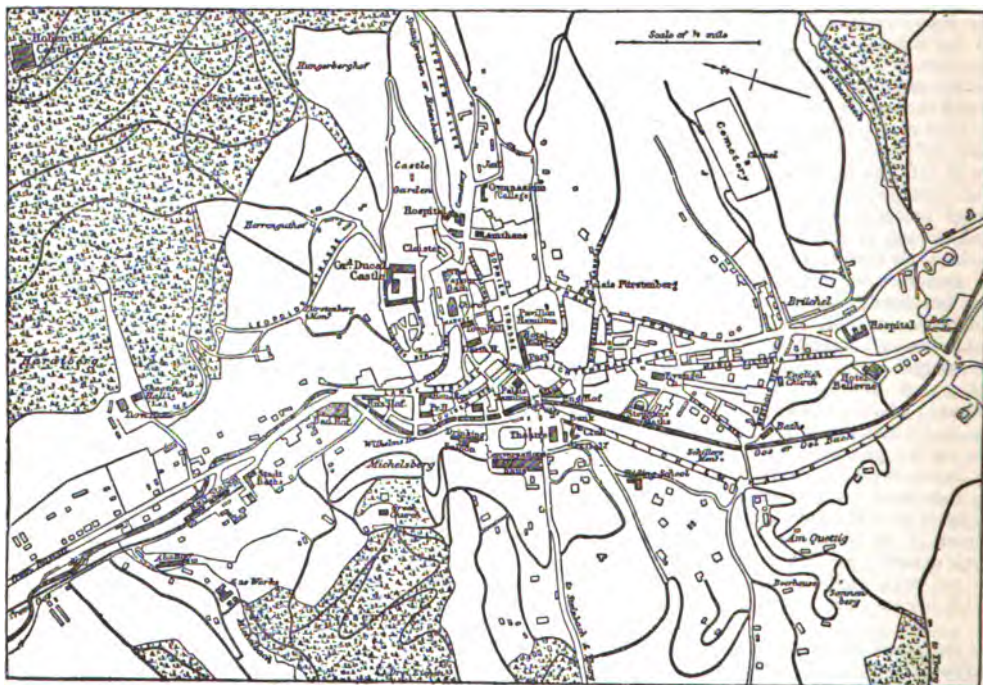

Ground-Plan of Baden-Baden.

**BADEN** (or **BADEN-BADEN**, to distinguish it from other places of the name), a town and celebrated watering-place of Germany, in the grand duchy of Baden. It stands on the side of a hill, near the Oos or Oel, in a beautiful valley of the Black Forest, 18 miles S.W. of Karlsruhe; and it is connected by a branch with the Manheim and Basel railway. The superiority of its situation, its extensive pleasure-grounds, gardens, and promenades, and the brilliancy of the life that is led during the season, have for a long series of years continued to attract crowds of visitors from all parts of the world. The resident population amounts to about 10,000, but that number is frequently augmented fourfold. The prevailing nationality is, or rather was, the French, but

Americans, Russians, and English are all numerously represented. The hot springs, which were among the earliest attractions of the place, are twenty-nine in number, and vary in temperature from 37° to 54° R., i.e., from 115° to 153° Fahr. They flow from the castle rock at the rate of 90 gallons per minute, and the water is conveyed through the town in pipes to supply the different baths. The town proper is on the right bank of the Oos, but the principal resorts of the adventitious population are on the other side. A *Conversationshaus* and a *Trinkhalle* or pump-room (1842), a theatre (1861), and a picture-gallery, are among the chief fashionable buildings, to which may be added the library and reading-room. The gaming-tables, which for so many

years were a striking feature of Baden-Baden, are now abolished. The only building of much antiquarian interest, with the exception of the castles, is the parish church, which dates from the 15th century, and contains the tombs of several of the margraves. There is a Protestant church a short distance to the east of Leopoldplatz, and not far off a small Episcopalian church; while on the Michaelsberg is the Greek chapel, with its gilded dome, which was erected over the tomb of the Roumanian prince, Michael Sroudza, who died at Baden in 1863.

The springs of Baden were known to the Romans, and the foundation of the town is referred to the Emperor Hadrian by an inscription of somewhat doubtful authenticity. The name of *Aurelia Aquensis* was given to it in honour of Aurelius Severus, in whose reign it would seem to have been well known. Fragments of its ancient sculptures are still to be seen, and in 1847 remains of Roman vapour baths, well preserved, were discovered just below the New Castle. From the 14th century down to the close of the 17th, Baden was the residence of the margraves, to whom it gave its name. They first dwelt in the Old Castle, the ruins of which still occupy the summit of a hill above the town, but in 1479 they removed to the New Castle (still so called), which is situated on the hill-side nearer to the town, and is remarkable for its subterranean dungeons. During the Thirty Years' War Baden suffered severely from the various combatants, but especially from the French, who pillaged it in 1643, and laid it in ashes in 1688. The margrave Sibylla rebuilt the New Castle in 1697, but the margrave Louis removed to Rastadt in 1706. Since the beginning of the present century the Government has greatly fostered the growth of the town.

BADEN, Switzerland, a small town in the canton of Aargau, on the Limmat, 14 miles N.W. of Zurich. It is much frequented on account of its warm medicinal springs, which are about 20 in number, and vary in temperature from 98° to 126° Fahr. About 15,000 persons visit the place annually. Tacitus, in the first book of his *Histories* (c. 67), incidentally speaks of it as *in modum municipii structus locus, amano salubrium aquarum usu frequens*; and numerous remains of pillars and inscriptions, coins, and other antiquities confirm his description. It was destroyed by the Alemanni and the Huns, but was again frequented during the reign of Charlemagne, though its modern prosperity only dates from the 15th century. For a long time the countship of Baden was in the hands of the Hapsburgs, but it was conquered by the Swiss Confederates in 1415. It was here that the famous disputation of Eck with Zwingle and Ecclampadius took place in 1526; and here was held the conference of 1589. In 1714 the peace which put an end to the war of the Spanish Succession was concluded at Baden between Austria and France; and four years afterwards a treaty between Zurich, Berne, and St Gall received its name from the town. Resident population, 3412.

BADEN, the chief town of a circle in Lower Austria, about 12 miles S. of Vienna on the railway to Gratz. It is beautifully situated at the mouth of the romantic *Helenenthal*, near the banks of the Schwachat, a rapid stream with several waterfalls, and has become a favourite summer resort with the inhabitants of the neighbouring capital. The warm baths, which give name to the town, are thirteen in number, and vary in temperature from 72° to 87° Fahr. They rise, for the most part, at the foot of the *Calvarienberg*, which is composed of dolomitic limestone. The number of patients is about 8000 annually. The celebrity of Baden dates back to the days of the Romans, who knew it by the name of *Aguas Cælia*; and remains of their occupation still exist. In 1812 the town suffered severely from a fire, but it has since been elegantly rebuilt. The principal buildings are the church of St Stephen, the theatre, the casino, and the

military hospital. A short distance to the west of the town stands the castle of Weilberg, which belongs to members of the imperial family. The only manufacture of much importance that is carried on in Baden is the production of steel-ware; these, especially the razors, are of excellent quality. Permanent population, about 6500.

BADGER (*Meles*), a family of Plantigrade Carnivora, possessing greatly elongated bodies and short limbs, each of the latter furnished with five toes, provided at their extremities with long, powerful claws, by means of which they form deep burrows in the earth. The carnassial tooth, which in the bears is wholly tuberculate, is in the badgers provided also with a cutting edge, their whole dentition being specially adapted to the partly vegetable, partly animal diet on which they subsist. The badger differs from all other mammals in having the lower jaw so articulated to the upper, by means of a transverse condyle firmly locked into a long cavity of the cranium, that dislocation of the jaw is all but impossible, and this enables those creatures to maintain their hold with the utmost tenacity. The European badger (*Meles Taxus*) may be taken as typical of the entire family. It is nowhere abundant, but is found over the entire northern parts of Europe and Asia. It is a quiet, inoffensive animal, nocturnal and solitary in its habits, sleeping by day in its burrow, and issuing forth at night to feed on roots, beech-mast, fruits, the eggs of birds, some of the smaller quadrupeds, frogs, and insects. It is said also to dig up the nests of wasps in order to eat the larvæ, as the ratel—a closely allied South African form—is said to rob the bees of their honey. The male and female are seldom seen together, and are supposed to trace each other by means of the odour of the secretion contained in a glandular pouch beneath the tail. Although the badger does not seek to attack, yet, when driven to bay, its great muscular power and tough hide renders it a formidable antagonist, as was often seen in the days, now happily gone by, when badger-baiting was a favourite amusement of the English peasantry. Fossil remains of the badger have been found in this country, apparently contemporaneous with the extinct cave bear, hyena, and tiger; still more ancient remains are said to have been found in the Red Crag of Suffolk, and should these prove authentic, the European badger, says Professor Owen, "will be the oldest known species of mammal now living on the face of the earth." The American badger (*Meles Labradorica*) is a native of California and Texas, and in its habits closely resembles the former species; it seems, however, to be more carnivorous. According to Gray, several species inhabit the southern parts of Asia. When badgers were more abundant than they now are, their skins dressed, with the hair attached, were commonly used for pistol furniture. They are now chiefly valued for the hair, that of the European badger being used in the manufacture of the best shaving-brushes, while the softer hair of the American species is employed for the same purpose, and also for painters' pencils. 5197 skins of the American badger were imported into London during 1873.

BADIA Y LEBLICH, Domingo, a celebrated Spanish traveller, better known under his assumed name of Ali Bey, was born in Biscay in the year 1766. After receiving a liberal education he devoted particular attention to the Arabic language, and made special preparation otherwise for his Oriental travels. Under the name of Ali Bey and in Mussulman costume, he visited Egypt, Morocco, Tripoli, Arabia, and Syria, and was received as a person of high rank wherever he appeared. On his return to Europe in 1807 he declared himself a Bonapartist, and was made Intendant, first of Segovia, and afterwards of Cordova. When the French were driven from Spain, Badia was compelled to take refuge in France, and there, in 1814, published an

account of his travels under the title of *Voyage d'Ali Bey en Asie et en Afrique, &c.*, in 3 vols. 8vo. A few years later he set out again for Syria, under the assumed name of Ali Othman, and, it is said, accredited as a political agent by the French Government. He only reached Aleppo, and there died, 30th August 1818, not without suspicion of having been poisoned.

**BADIUS**, **JODOCUS** or **JOSSE**, sometimes called **BADIUS ASCENSIVS** from the village of Asche, near Brussels, where he was born in 1462, was an eminent printer at Paris, whose establishment was celebrated under the name of *Prelum Ascensianum*. He was himself a scholar of considerable repute, had studied at Brussels and Ferrara, and before settling in Paris, had taught Greek for several years at Lyons. He illustrated with notes several of the classics which he printed, and was the author of numerous pieces, amongst which are a life of Thomas à Kempis, and a satire on the follies of women, entitled *Navicula Stultarum Mulierum*. He died in 1535. His epitaph was written by his grandson, the celebrated Henry Stephanus.

**BADMINTON**, a game of recent introduction. It may be played in or out of doors, by any number of persons from two to eight; two or four makes the best game. The

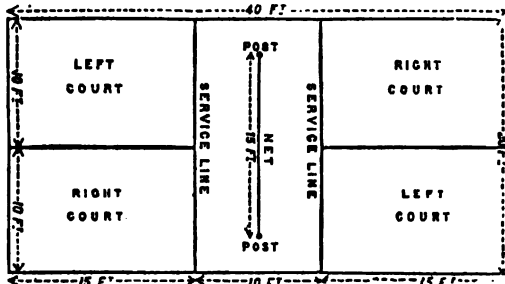

Diagram illustrating the Game of Badminton.

following description applies to the outdoor game; the indoor follows the same plan, modified only by circumstances affecting a room.

A tolerably level surface is required to form a *ground*. Turf or asphalt is the best. The size of the ground varies from 40 ft. by 20 ft. to 30 ft. by 15 ft., according to the space at command and the activity of the players.

The ground is divided into *courts* as shown in the diagram, which gives the marking-out and measurements of a full-sized ground.

The *boundaries* of the ground and of the courts should be defined by means of whitening and water, or pegged-down tape, the former being preferable.

On each of the spots marked "post," half-way between the service lines, and 15 ft. apart, a *post* about 6 ft. high must be erected, either on a stand or driven into the ground, and supported by guy-ropes.

A *net*, about 5 ft. 6 in. or 5 ft. high should be stretched from post to post. The depth of the net is of but little consequence. Where expense is no object, it should reach to the ground.

The implements required in playing the game are—(1), *shuttlecocks*, and (2), *rackets* or *battledores*. The former should be about 5 in. high, and about 1 oz. in weight. For outdoor play the shuttlecocks are sometimes made heavier by being loaded with lead. The body should be covered with india-rubber. The rackets should be similar to those used at the game of the same name, only smaller, about 2 ft. 6 in. long.

The game consists in sending the shuttlecock with the racket over the net, forwards and backwards, until one of the players fails to return it. The players decide

by lot which shall commence or have first *hand-in* and choice of ends. The player who is hand-in (say A) stations himself in one of the courts at his end, his adversary (say B) in the diagonally opposed court at the other end. A then *serves* to B, i.e., A standing in the court chosen by him, strikes the shuttlecock over the net with the racket into the diagonally opposed court. B then has to *return the service* by striking the shuttlecock back over the net without allowing it to touch the ground, and so on alternately until one player fails. If this is the player who served, he is hand-out, his adversary becomes hand-in, and serves, and no score accrues. But if the player failing is the one who was served to, his adversary scores one point towards game, called an *ace*. The player who first scores 15 aces wins the game; but if the score arrives at 14 all, it is necessary for one player to score two consecutive aces in order to win.

The server must serve according to the following conditions:—He must stand with both feet in the court served from; he must send the shuttlecock clean over the net (i.e., without touching net or posts), and so that it will drop into or beyond the service line bounding the court served into, and into the diagonally opposed court. If he fails to comply with these conditions it is a *fault*, and he has to serve again. Two consecutive faults put his hand out.

The server's hand is also out if he fails to send the shuttlecock over the net; if he hits the shuttlecock beyond the external boundary of the ground, or more than once; or, if after the server has loosed it, it touches him. No fault is allowed for these failures, as they are considered more serious than those first enumerated. After service is properly given, if either player fails to return the shuttlecock clean over the net, and so that it drops within the external boundary of the ground on the side of the net furthest from the striker, the player failing loses an ace, or is hand-out as the case may be. It will be observed that in the service the shuttlecock must be sent from right court to right court, or from left to left, but in the return, by either player, it is only required that the shuttlecock shall drop within any part of the ground, bounded by the external line of all. In addition the shuttlecock must be struck before it touches the ground, and must be touched only with the racket, and must only be hit once, otherwise it counts against the striker. If the shuttlecock drops on the line enclosing the court served into, or in the return drops on the boundary line, it is generally reckoned as a *let*, i.e., the stroke or innings goes for nothing, and the server serves again. But this is an utterly useless rule, and it is better to count everything that drops on the line to the striker.

In the case of a fault, or in the case of returns that are not according to the conditions, if the adversary returns or attempts to return the shuttlecock, the service or return counts the same as though it had been properly made. If the server scores he serves again, this time from his other court, and so on alternately from one court to the other as long as he scores. When he is hand-out, his adversary commences serving from either of the courts at his end, and, on scoring, serves from his other court, and so on. In partner games the disposition of the players, and the rules by which they conduct the game, as to the two hands in, and so forth, are identical with those which prevail at lawn tennis. See TENNIS. (H. J.)

**BADNUR**, the headquarters of the district of Betāl, consists, besides the European houses, of two *bázars*. The largest, the Kothi Bázár, has a population of 2015 souls. The public buildings are the Commissioner's court-house, the district court-house, the jail, the schools, the police-station, the post-office, the dispensary, &c. There is a good *seráí* or inn for native travellers, and a *dhá bangalow* or resting-place for Europeans. Not far from Badnúr is Kherlá, the former residence of the Gond Rájá, where



there is an old fort, now in ruins, which used to be held by them. Lat. 21° 57' N., long. 77° 59' E.

**BADRINATH**, a town and celebrated temple in Hindustán, in the British district of Garhwal, situate on the right bank of the Viahnuganga, a tributary of the Alaknandá River, in the middle of a valley nearly 4 miles in length, and 1 in breadth, in 30° 44' N. lat. and 79° 32' E. long. The town is small, containing only twenty or thirty huts, in which reside the Bráhmans and the attendants on the temple. The building, however, which is considered a place of high sanctity, by no means corresponds to its great celebrity. It is about 40 or 50 feet in height, built in the form of a cone, with a small cupola, on the top of which is a gilt ball and spire, and contains the shrines of Badrináth, dedicated to an incarnation of Viahnu. The principal idol is of black stone, and is 3 feet in height. Badrináth is the favourite resort of pilgrims from all parts of India. In ordinary years the number varies from 7000 to 10,000; but every twelfth year, when the festival of Kumbh Melá is celebrated, the concourse of persons is said to be 50,000. In addition to the gifts of votaries, the temple enjoys a further source of revenue from the rents of villages assigned by former Rájás. Some years ago the temple was shattered by an earthquake, and has only been partially restored. It is situate among mountains rising 23,000 feet above the level of the sea. Elevation of the site of the temple, 10,294 feet.

**BAENA**, a town of Spain, in the province of Cordova, 8 leagues S.E. of the city. It is picturesquely situated, near the River Marbello, on the slope of a hill crowned with a castle, which formerly belonged to Gonzalo de Cordova, and is now the property of the Altamira family. It has four parish churches and three schools, one of which, exclusively for girls, has a high reputation in the province. The education, which is conducted by sisters of charity, does not go beyond reading, writing, arithmetic, and religious instruction. Grain and oil are the principal articles of commerce. The site of the Roman town (*Bantiana* or *Bisiana*) can still be traced, and various antiquities are frequently met with. A subterranean vault was discovered in 1833, containing twelve cinerary urns, with inscriptions commemorating various members of the Pompeian family. In 1292 Mahomet Ibn Aljama vainly besieged the city, the defence of which on that occasion is commemorated by the five Moorish heads in its coat-of-arms. Baena is the birthplace of Juan de Peñalosa. Population, about 12,000.

**BÆZA** (ancient *Beatia*), a city of Spain, in the province of Jaen. It stands on a considerable elevation, about 3 miles from the right bank of the Guadalquivir. Lat. 37° 59' N., long. 3° 28' W. It is well built, and has a cathedral and several fine public buildings, among which the most worthy of notice are the university (founded in 1533, and for some time defunct), the oratorio of the order of St Philip Neri, and the marble fountain with Caryatides in the Plaza de la Constitución. The Cordova and Ubeda gates, and the arch of Bæza, are among the remains of its old fortifications, which were of great strength. There is little trade or manufacture here. The principal productions of the neighbourhood are grain and oil. The red dye made from the native cochineal was formerly celebrated. In the time of the Moors Bæza was a flourishing city of 50,000 inhabitants, and the capital of a separate kingdom, but it never recovered from the sack of 1239. It is the birthplace of Gaspar Becerra, the celebrated sculptor and painter. Present population, about 11,000.

**BAFFIN, WILLIAM**, an able and enterprising English seaman, born in 1584. Nothing is known of his early life, and his fame rests entirely on the voyages undertaken by him during the years 1612 to 1616. In 1612 he accompanied Captain James Hall on his fourth voyage in search

of the north-west passage, and in 1613 he commanded one of the English vessels engaged in the Greenland fisheries. In 1615 and 1616 Baffin made two voyages in the "Discovery" under Bylot, and on the second of them explored the large inlet, afterwards called Baffin's Bay. The only accounts of these expeditions were given by Baffin himself, and later investigators have thoroughly confirmed his descriptions. In 1618 he is said to have been mate in a voyage to Surat and Mocha; and in 1621 he was killed while attempting, in conjunction with a Persian force, to expel the Portuguese from Ormuz. (See Purchas's *Pilgrims* and the publications of the Hakluyt Society for 1849.)

**BAFFIN'S BAY**, or **BAFFIN'S SEA**, is properly neither a bay nor a sea, but part of the long strait or inlet which separates Greenland from the N.E. coast of America. It extends from about 69° to 78° N. lat., and from 54° to 72° W. long, and is connected by Lancaster Sound and Barrow's Strait with the Arctic Ocean. It was first explored in 1616 by the English navigator Baffin. The part of the strait to the south is known as Davis Strait, and the narrower channel to the north takes the name of Smith's Sound. The coasts are generally high and precipitous, and are deeply indented with gulfs. The most important island on the east side is Disco to the north of Disco Bay, where there is a Danish settlement. During the greater part of the year this sea is frozen, and it is navigable only from the beginning of June to the end of September. It is annually visited by vessels engaged in the whale and seal fishery. (See Petermann's *Mittheil.*, 1873, map 13, and Markham's *Cruise in Baffin's Bay*.)

**BAGATELLE** is an indoor game, probably derived from the old English shovel-board, described by Cotton in his *Compleat Gamester* (1674), though many consider that its invention is due to the French. Like billiards, chess, and draughts, its origin is not certainly known; but whatever its genesis, its name is undoubtedly French. Bagatelle games are played on an oblong board, usually from six to ten feet in length, by a foot and a half to three feet in width. The bed of the table, which is ordinarily of slate or mahogany, is covered with fine green cloth; and at the upper end, which is rounded, there are nine holes or cups, numbered from 1 to 9, thus

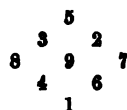

Into these holes ivory balls are driven by a cue in all respects similar to the instrument used in BILLIARDS, which see. The sides and circular end of the table are furnished with elastic cushions; and in some of the newer tables there is also a pocket on each side. Nine balls—eight white, and one red or black (sometimes four white, four red, and one black)—are used in the most popular of the several bagatelle games.

The ordinary game is played according to the following rules:—

1. Any number of persons may play, whether singly or in sides.
2. Each player strings for lead, and he who lodges his ball in the highest hole begins. In the case of partners, one only on each side need string for the lead.
3. The player who wins the lead takes the nine balls and plays them one after the other up the table from baulk, first striking at the red ball which is placed on the spot about a foot below the 1 hole. The object of the player is to lodge his own, or the coloured ball, or both balls, in the holes.
4. The red ball counts double when it is played into a hole; and for each white ball lodged or holed, a corresponding number of points is scored to that marked

in the cup. (Sometimes two coloured balls are used, in which case both count double.) 5 The red ball must be first struck, and the remainder of the balls are played up to the holes—the sum total of the holes made being the striker's score. 6. Any number of rounds may be played for the game, as agreed on at the commencement; and the player (or side) obtaining the highest aggregate score wins. 7. Any ball that rebounds beyond the baulk line, or is forced over the table, is not re-used in that round.

*Sans Egal*, or the French Game, is the next most generally played game on the bagatelle table. It is governed by the following laws:—1. The player who takes the lead (which is decided as in bagatelle) makes choice of four balls of either colour, and placing the black one on the spot, commences by striking it with a ball from baulk. 2. The other player then strikes up one of his balls, and so on alternately. 3 He who holes the black ball counts it towards his game, together with any number made by the white. 4. If either player hole his adversary's ball, the number scored by such ball, or balls, is marked to the other side. 5. The player who makes the greatest number of points in each round wins the game, and takes the lead in the next. The rule as to balls rebounding beyond the baulk line, or being forced off the table, is the same as in the preceding game.

*The Cannon Game*, sometimes played on a table without holes, consists entirely of cannons, that is to say, two balls struck in succession by the cue-ball. This game is played 50, 100, or 150 up, and the holes into which the balls fall are sometimes counted in addition to the cannon. Three balls only are used—a white, a spot-white, and a black ball. At starting the latter is placed on the spot, and the adversary's ball on a point equi-distant between the first and centre holes, 1 and 9. If the striker make a cannon, he goes on as long as he can score, but no hole can be counted without first making the cannon. To miss the white involves the loss of 1 point; and to miss the black ball, 5 points. The striker's break is ended when he fails to cannon, and then the other player goes on,—he who first gains the required number winning the game. When there are pockets to the table, two points are taken for every white ball pocketed, and three points for the red. Should the player's ball fall into a pocket before he make the cannon, the score is taken by the opponent. In the *Irish Cannon Game* the holes do not count, except by way of penalty; all points made by holing the balls being added to the score of the adversary. Sometimes, in both the cannon games two points are taken for a cannon from white to white and then to red, and three for a cannon from white to red and then to white; or, when two coloured balls are used, three points are taken for a cannon from the black to the red. Lately, bagatelle tables as much as 14 feet long by 6 feet wide have been made for the cannon game.

*Mississippi* is a game played on a bagatelle table with a bridge pierced with arches, each arch bearing a certain number—say, from 1 to 10 or 12. The balls are first played from the baulk against the cushion on to the bridge, which is placed just in front of the lowermost hole. The rules are—1. If the ball pass through the bridge, all the points indicated on the arch are counted towards the player's score, in addition to any points made by the ball falling into a hole beyond the bridge. The game may be played by two or more persons, and he who first makes the number of points agreed on—100, 200, 500, &c.—wins. A modification of this game is called

*Trou Madame*. In this the balls are played from the baulk straight up to the bridge without touching the cushion, and only the points marked upon the arches score,—all points made by the balls dropping into the holes beyond being scored to the opponent. Another variety, called

*Cockamaroo*, or Russian Bagatelle, is played on a table prepared with a number of pins, holes, arches, and balls, up to and through which the ball is played from the baulk end of the table. It is a childish amusement, requiring little skill, and therefore needing only the barest mention.

In playing the bagatelle games a much less degree of force is required for the stroke than is necessary for billiards. Some adepts are able to fill all the holes at one essay; first, by striking the red ball on the side, making a double hazard, say, into the 7 and the 8 holes, and then, either by playing direct at the holes or at the cushion, lodging each successive ball till the whole nine are pocketed. In this way, counting double for the red, as many as 54 points can be scored in a single round of the balls. When two coloured balls are used, of course a proportionally larger score is made. The cue should be held lightly between the fingers and thumb, not grasped in the palm of the hand; and much use may be made of the various strokes employed in billiards,—as the side, the screw, the twist, and the drag; for which terms see the article **BILLIARDS**. (G. F. P.)

**BAGGESEN**, JENS EMMANUEL, the most prominent literary figure in Denmark during the latter part of last century, was born on the 15th of February 1765, at Korsør. His parents were very poor, and before he was twelve he was sent to copy documents at the office of the clerk of the district. By dint of indomitable perseverance, he managed to gain an education, and in 1782 entered the university of Copenhagen. His success as a writer was coeval with his earliest publication; his *Comical Tales* in verse, poems that recall the *Broad Grins* that Colman the younger brought out a decade later, took the town by storm, and the struggling young poet found himself a popular favourite at twenty-one. He then tried serious lyrical writing, and his tact, elegance of manner, and versatility, gained him a place in the best society. This sudden success received a blow in 1788, when a very poor opera he had produced was received with mockery, and a reaction against him set in. He left Denmark in a rage, and spent the next years in Germany, France, and Switzerland. In the country last mentioned he married, began to write in German, and published in that language his next poem, *Alpenlied*. In 1790 he returned to his mother-country, bringing with him as a peace-offering his fine descriptive poem, the *Labyrinth*, in Danish, and was received with unbounded homage. The next twenty years were spent in incessant restless wanderings over the north of Europe, Paris latterly becoming his nominal home. He continued to publish volumes alternately in Danish and German. In 1811 he returned to Copenhagen to find the young Ohlenschläger installed as the great poet of the day, and he himself beginning to lose his previously unbounded popularity. Until 1820 he resided in Copenhagen, in almost unceasing literary feud with some one or other, abusing and being abused, the most important feature of the whole being Baggesen's determination not to allow Ohlenschläger to be considered a greater poet than himself. He then went back to his beloved Paris, where he lost his wife and youngest child, and fell at last into a state of hopeless melancholy madness. In 1826, having slightly recovered, he wished to see Denmark once more, but died at Hamburg on his way, on the 3d of October, and was buried at Kiel. His many-sided talents achieved success in all forms of writing, but his domestic, philosophical, and critical works have long ceased to occupy attention. A little more power of restraining his egotism and passion would have made him one of the wittiest and keenest of modern satirists, and his comic poems are deathless. The Danish literature owes Baggesen a great debt for the firmness, polish, and form which he introduced into it—his style being always finished

and elegant. With all his faults he stands as the greatest figure between Holberg and Ohlenschläger. Of all his poems, however, the loveliest and best is a little simple song, called *There was a time when I was very little*, which every Dane, high or low, knows by heart, and which is matchless in its simplicity and pathos. It has outlived all his epics.

(E. W. G.)

BAGHDAD, a Turkish pashalic or government of Asia, computed to have an area of above 100,000 square miles. It stretches in a N.W. direction, from the mouth of the Shatt-el-Arab at Bussorah, to Merdin, situated near the source of the Tigris; and from the confines of Persia to the banks of the Khabour, which separates it from the pashalic of Diarbekir. Its general boundaries are the Euphrates and the Arabian desert of Nejd to the W. and S., Kusistan and Mount Zagros to the E., the pashalic of Diarbekir to the N.W., and Armenia with the territories of the Kurdiash chief of Julamerick to the N. This great tract comprehends ancient Babylonia and the greatest part of Assyria proper. The first includes the space enclosed by the Tigris and the Euphrates, which is also known under the general appellation of Mesopotamia; and the second, that which is beyond the Tigris, commonly called Lower Kurdistan. This tract of country is an extensive and very fertile plain, and is watered by the Tigris and the Euphrates, which at Baghdad approach within 25 miles of each other, and afford an inexhaustible supply of the finest water. Only some parts of these fertile districts, however, are cultivated, as the population consists in many places of wandering Arabs, who are averse to agriculture, and who, in their vagrant life of idleness and rapine, neglect all the natural advantages of the country. The most productive portion of the pashalic is on the banks of the Shatt-el-Arab, in the neighbourhood of Bussorah. This tract, for upwards of 30 miles below that city, is well cultivated, and yields vast quantities of dates, wheat, barley, and various kinds of fruits. The banks of the Euphrates produce abundant crops of dry grain. Higher up the Euphrates, the country which is possessed by the Arabs is a low marshy tract, formed by the expansion of the Euphrates, and is famed for plentiful crops of rice. Among the mountainous districts of the Upper Euphrates the country is highly picturesque and beautiful; it is watered by the River Mygdonius (the Gozan of Scripture), and is in a tolerable state of cultivation. It produces in abundance the finest fruits, such as grapes, olives, figs, pomegranates, which are considered the most delicious in the East; apples, pears, apricots of an inferior quality; and the finest dates, on which the inhabitants, as in other parts of Asia, depend in many cases for subsistence. The domestic animals are, the horse, for which the country has long been famed, the ass, camel, dromedary, buffalo, and mule. Of the wild animals, the lion, the hyena, the jackal, the wolf, and the wild boar, are common; and antelopes are very numerous. Hares are plentiful, but foxes are seldom seen. All sorts of poultry are bred except the turkey. On the cultivated lands, and on the borders of the rivers, the black partridge is met with in great numbers. Snipes and almost every species of wild fowl may be found in the marshes, and pelicans on the banks of the Euphrates and Tigris. In addition to these two rivers, the country is watered by the Khabour or Chaboras, formed by the junction of several small streams about ten miles to the S.W. of Merdin, and by the Mygdonius, or Gozan, the Hermas of the Arabs, which used formerly to discharge a part of its waters into the Euphrates through the Khabour, and a part into the Tigris through the Thirthar, passing by Hatra, but which is now entirely lost in a salt marsh at the foot of the Singar hills.

In ancient times the plain of Mesopotamia was occupied by the great and wealthy cities of Ninevah, Babylon, Selcucia, Ctesiphon, &c., and was in a high state of cultivation. It was intersected by many well-constructed canals and other works, which, in dispersing over the country the superfluous waters of the Tigris and Euphrates, proved extremely useful to agriculture. These works are now all ruined, and not a vestige remains of many of the canals, while the course of others can only be faintly traced in their imperfect remains. One canal, however, called El-Hye, still exists; it connects the Euphrates and the Tigris exactly half-way between Bussorah and Baghdad, and is navigable in spring for large boats.

BAGHDAD, a city of Asia, formerly the capital of the empire of the caliph, and long renowned for its commerce and its wealth, is situated on an extensive and desert plain, which has scarcely a tree or village throughout its whole extent; and though it is intersected by the Tigris, it stands mostly on its eastern bank, close to the water's edge. Old Baghdad on the W. is now considered as merely a suburb to the larger and more modern city on the eastern shore, the former containing an area of only 146 acres, while the latter extends over 591. It has, however, numerous and extensive streets, well furnished with shops, and is protected by strong walls, with three gates opening towards Hillah on the Euphrates and Kazimeen. Beyond these modern bulwarks vestiges of ancient buildings, spreading in various directions, are visible in the plain, which is strewn with fragments of brick, tiles, and rubbish. A burying-ground has extended itself over a large tract of land formerly occupied by the streets of the city; and here is the tomb of Zobeide, the favourite wife of Haroun el Raschid, built of brick, of a high octagonal shape, and surmounted by a lofty superstructure in the form of a cone. It was originally built in 827 A.D., but has been frequently restored. The two towns of Old and New Baghdad are connected by a bridge of thirty pontoons. The form of the new city is that of an irregular oblong, about 1500 paces in length by 800 in breadth; and a brick wall, about five miles in circuit, encloses the town on both sides of the river. This wall, which is built of brick, has been constructed and repaired at different periods; and, as in most other works of the same nature in Mahometan countries, the oldest portion is the best, and the more modern the worst part of the fabric. At the principal angles are large round towers, with smaller towers intervening at short distances; and on these large towers batteries are planted, with brass cannon of different calibre, badly mounted. Of two of these angular towers Mr Buckingham remarked that the workmanship is equal to any ancient masonry that he had ever seen. The wall has three gates—one on the S.E., one on the N.E., and a third on the N.W. of the city; and it is surrounded by a dry ditch of considerable depth. A fourth gate on the northern side, which has been closed since the capture of the city by Sultan Amurath IV. in 1638, is a good specimen of Saracenic brick-work. It was formerly called "the white Gate," but is now known as the "*Bab-el-Tvism*," or "Talismanic Gate," from a fine Arabic inscription in relief on a scroll border round the tower, which bears the date of 618 A.H. (1220 A.D.) The town has been built without the slightest regard to regularity. The streets are even more intricate and winding than those in most other Eastern towns; and, with the exception of the bazaars and some open squares, the interior is little else than a labyrinth of alleys and passages. The streets are unpaved, and in many places so narrow that two horsemen can scarcely pass each other; and as it is seldom that the houses have windows facing the great public thoroughfares, and the doors are small and mean, they present on both sides the

gloomy appearance of dead walls. All the buildings, both public and private, are constructed of furnace-burnt bricks, of a yellowish-red colour, taken chiefly from the ruins of other edifices, as their rounded angles evidently show. A house is generally laid out in ranges of apartments opening into a square interior court, and furnished with subterranean rooms called *serdauba*, into which the inhabitants retreat during the day for shelter from the intense heats of summer; and with terraced roofs, on which they take their evening meal, and sleep in the open air. Occasionally in the months of June, July, and August, when the *Sherki* or south wind is blowing, the thermometer at break of day is known to stand at 112° Fahr.; while at noon it rises to 119°, and a little before two o'clock to 122°, standing at sunset at 117°, and at midnight at

114°. But this scale of temperature is exceptional. During the summer months the wind is usually in the north-west, and the air, though hot, is fresh and exhilarating, the thermometer ranging from about 75° at sunrise to 107° at the hottest time of the day. The interiors of the houses of the rich are splendidly furnished, and ornamented in the ceilings with a sort of chequered work, which has a handsome appearance. A great portion of the ground within the walls of the town is unoccupied by buildings, especially in the north-eastern quarter; and even in the more populous parts of the city near the river, a considerable space between the houses is occupied by gardens, where pomegranates, grapes, figs, olives, and dates grow in great abundance, so that the city when seen from a distance has the appearance of rising out of the midst of trees.

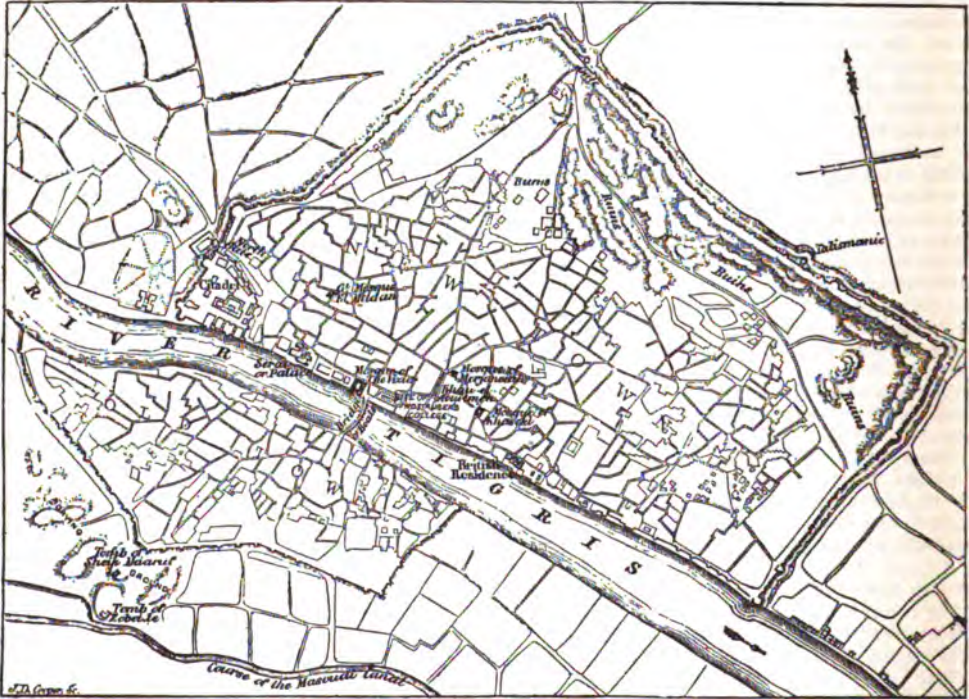

Ground-Plan of the Encinte of Baghdad.

Reduced from Survey made by Commander F. Jones and Mr W. Collingwood of the Indian Navy, 1843-54.

The principal public buildings in Baghdad are the mosques, the khans or caravanserais, and the serai or palace of the pasha. The palace, which is situated in the north-western quarter of the town, not far from the Tigris, is distinguished rather for extent than grandeur. It is a comparatively modern structure, built at different periods, and forming a large and confused pile, without proportion, beauty, or strength. There are no remains of the ancient palace of the caliphs.

In all Mahometan cities the mosques are conspicuous objects. The number in Baghdad is above 100; but of these not more than thirty are distinguished by the characteristic minarets or steeples, the rest being merely chapels and venerated places of prayer. The most ancient of these mosques was erected in the year of the Hegira 633, or 1235 of the Christian era, by the Caliph Mustansir. All that remains of the original building is the minaret, and a small portion of the outer walls; the former a short, heavy erection, of the most ungraceful proportions, built

of bricks of various colours, diagonally crossed. The *jama* or mosque of Merjaneeah, not far distant from the former, though the body of it is modern, has some remains of old and very rich arabesque work on its surface, dating from the 14th century. The door is formed by a lofty arch of the Pointed form, bordered on both sides by rich bands exquisitely sculptured, and having numerous inscriptions. The mosque of Khaseki, supposed to have been an old Christian church, is chiefly distinguished by the niche for prayer, which, instead of a simple and unadorned recess, is crowned by a Roman arch, with square pedestals, spirally fluted shafts, a rich capital of flowers, and a fine fan or shell-top in the Roman style. Around the arch is a sculptured frieze; and down the centre, at the back of the niche, is a broad band, richly sculptured with vases, flowers, &c., in the very best style of workmanship,—the whole executed on a white marble ground. The building in its present state bears the date of 1682 A.D., but the sculptures which it contains belong probably to the time of the early

alipha. The mosque of the visier, near the Tigris, has a fine dome and lofty minaret; and the great mosque in the square of El Meidan is also a noble building. The others do not merit any particular notice. The domes of Baghdad are mostly high, and disproportionately narrow. They are richly ornamented with glazed tiles and painting, the colours chiefly green and white, which, being reflected from a polished surface, impart more liveliness than magnificence to the aspect of these buildings. In the opinion of Mr Buckingham, they are not to be compared to the rich and stately domes of Egypt, as the minarets, although they have the same bright assemblage of colours, are far from being equal "to the plain and grave dignity of some of the Turkish towers at Diarbekir, Aleppo, and Damascus, or to the lighter elegance of many of those in the larger towns on the banks of the Nile."

There are about thirty khans or caravanserais in Baghdad, all of inferior construction to those in the other large towns of Turkey. The only remarkable building of this class is called *Khan-el-Aourmah*, and adjoins the Merjaneeah mosque, to which it formerly belonged. The vaulted roof of this building is a fine specimen of Saracenic brick-work, and like the adjoining mosque, bears the date of 1366 A.D. It is said, however, to occupy the site of an ancient Christian church. The bazars, which are numerous, are mostly formed of long, straight, and tolerably wide avenues. The one most recently built is the largest and the best; still it has an air of meanness about it that is not common in the bazars of large Turkish cities. It is long, wide, and lofty, and well filled with dealers and wares of all sorts. Several of these bazars are vaulted over with brick-work; but the greater number are merely covered with flat beams which support a roof of straw, dried leaves, or branches of trees and grass. There are about fifty baths in Baghdad, which are also very inferior in their accommodations to those in the other large towns of Mesopotamia. The only other Mahometan remains which it is necessary to mention are—1. The Tekiyeh, or shrine of the Bektash dervishes, on the western bank of the river. The shrine is in ruins, but it contains a fine Cufic inscription now mutilated, which bears the date of 333 A.H. (or 944 A.D.) 2. The tomb of the famous Mearuf-el-Kerkhi, in the immediate vicinity, dating from 1215 A.D. 3. In Eastern or New Baghdad the college of Mustansir, near the bridge, now in ruins, but bearing a fine inscription dated 630 A.H. (or 1233 A.D.) 4. The shrine of the famous Saint Abdul Kadir, which is visited by pilgrims from all parts of the Mahometan world. The original tomb was erected about 1252 A.D., but the noble dome which now canopies the grave dates from about two centuries later. An aqueduct, the only one in the city, conveys water from the river to this shrine. None of the other mosques or tombs require particular notice.

Baghdad is about 500 miles from the mouth of the Tigris (following its course), and about 400 from Bussorah; and with the latter place it carries on a constant communication by means of boats of from twenty to fifty tons burden, though the river is navigable for larger vessels. With a northerly wind these boats will make the passage to Bussorah in seven or eight days; in calms, when they have merely the aid of the current, the passage occupies from ten to fifteen days. Sir R. K. Porter mentions that the stream of the Tigris runs at the rate of seven knots an hour. This, however, is probably during floods, since, with such a powerful current, a boat could not occupy ten or fifteen days on its passage from Baghdad to Bussorah. In coming up the stream, thirty or forty days are required to reach Baghdad. Of late years, however, steam communication has almost entirely superseded the use of the native craft between Baghdad and Bussorah. British steamers were first placed upon

the Tigris and Euphrates by Colonel Chesney in 1836, and, with the sanction of the Turkish Government, they have ever since been maintained there, one small vessel of the Indian naval service being attached to the British Residency, and two commercial steamers belonging to an English company being employed in navigating the Tigris for trade purposes. The Turks have also endeavoured to establish a line of mercantile steamers of their own between Baghdad and Bussorah, but they have not hitherto been very successful. The smaller craft, used for bringing supplies of provisions and fruit to the city, are circular boats of basket-work, covered with skins, the same that have been employed from the remotest antiquity. The Euphrates and the Tigris are liable to spring floods; and the streams of both rivers being sometimes joined, inundate the desert plain on which Baghdad stands, when the city appears like an island in the midst of the sea. The inhabitants are supplied with water from the Tigris, which is brought to their houses in goats' skins, the convenience of water-works, cisterns, and pipes being entirely unknown.

Baghdad has much declined from its ancient importance. It was formerly a great emporium of Eastern commerce; and it still receives, by way of Bussorah, from Bengal the manufactures and produce of India, which are distributed over Arabia, Syria, Kurdistan, Armenia, and Asia Minor. At the same time the inland trade from Persia and the East has fallen off. The productions and manufactures of Persia, which were intended for the Syrian, Armenian, and Turkish markets, and were sent to Baghdad as a central depot, now reach Constantinople by the more direct route of Erzerum and Tocat. Wealth, indeed, appears to be deficient among all classes, and Baghdad has many symptoms of a decayed city. It must, however, be noted that a very considerable trade has sprung up of late years between the European markets and Baghdad, several English houses being established in the city, who import goods direct from London and Liverpool, *via* the Suez Canal and Bussorah, and French, German, Swiss, and Greek merchants being also engaged in the traffic. The staple articles of export are dates, wool, and grain, to which may be added cloth of various kinds, drugs, dye-stuffs, and miscellaneous productions. A very considerable trade in horses is also carried on. The total value of the exports in 1870-71 reached about £46,900, while the imports for the same year were stated at upwards of £285,000. There is a considerable manufacture of red and yellow leather, which is made into shoes, and finds a ready sale.

The population is a mixture of nations from various quarters of the East. The chief officers of Government, whether civil or military, are of the families of Constantinopolitan Turks, though they are mostly natives of the city; the merchants and traders are almost all of Persian or Arabian descent; while the lower classes consist of Turks, Arabs, Persians, and Indians. There are some Jews and Christians, who still remain distinct from the other classes; while the strangers in the town are Kurds, Persians, and desert Arabs in considerable numbers. The dress of the Baghdad Turks is not nearly so gay or splendid as that of their northern countrymen; and the costume of the residents is, upon the whole, unusually plain in comparison with that of other Asiatic. As every nation retains its own peculiar dress, it may be easily conceived what an amusing variety of costume must be seen in the streets of Baghdad. The dress of the females is as mean as that used in the poorest villages of Mesopotamia; women of all classes being enveloped in a blue checked cloth, such as is worn by the lowest orders in Egypt, and having their faces covered by hideous veils of black horse-hair.

Baghdad is governed by a pasha, assisted by a council. He was formerly chosen from the ranks of the Georgian

Mamelukes, but is now always selected from among the highest officers of the Constantinople court, his term of office being usually for four or five years. He is also governor-general of Irak, and possesses supreme authority from Diarbekir to Bahrein, though he does not under ordinary circumstances interfere with the subordinate governments of Mosul and Kurdistan.<sup>1</sup>

The East India Company used to maintain a resident in Baghdad with a large establishment, and his post is now replaced by that of a consul-general and political agent. A French consul is also regularly appointed.

Until recently Baghdad was supposed to be entirely a Mahometan city, dating from the time of Al Mansur; but Sir H. Rawlinson discovered in 1848, during an unusually dry season, when the rivers had fallen six feet below the ordinary low-water mark, that the western bank of the Tigris was lined with an embankment of solid brick-work, dating from the time of Nebuchadnezzar, as the bricks were each stamped with his name and titles; and it has been since remarked that in the Assyrian geographical catalogues of the time of Sardanapalus, one of the Babylonian cities bears the name of *Bagdad*, and may thus very possibly represent the Arab site of the capital of the caliphs. According to the Arabian writers, however, there were no traces of former habitation when Al Mansur laid the foundation of the new city. It was adorned with many noble and stately edifices by the magnificence of the renowned Haroun el Raschid, who also built on the eastern side of the river, connecting the two quarters of the town by a bridge of boats. Under the auspices of Zobeide, the wife of that prince, and Jaffer the Barmecide, his favourite, the city may be said to have attained its greatest splendour. It continued to flourish and increase, and to be the seat of elegance and learning, until the 656th year of the Hegira (1277 A.D.), when Hulaku the Tatar, the grandson of Genghis Khan, took it by storm, and extinguished the dynasty of the Abbassides. The Tatars retained possession of Baghdad till about the year 1400 of our era, when it was taken by Timur, from whom the Sultan Ahmed Ben Avis fled, and finding refuge with the Greek emperor, contrived afterwards to repossess himself of the city, whence he was finally expelled by Kara Yusuf in 1417. In 1477 his descendants were driven out by Usum Cassim, who reigned 39 years in Baghdad, when Shah Ismael the First, the founder of the royal house of Sefi, made himself master of it. From that time it continued for a long period an object of contention between the Turks and Persians. It was taken by Soliman the Magnificent, and retaken by Shah Abbas the Great; and it was afterwards besieged by Amurath the Fourth, with an army of 300,000 men. After an obstinate resistance, it was forced to surrender 1638 A.D.; when, in defiance of the terms of capitulation, most of the inhabitants were massacred. Since

<sup>1</sup> Besides the court of superior officers which assists the pasha in the general administration of the province, there is also a Mejlis, or mixed tribunal, for the settlement of municipal and commercial affairs, to which both Christian and Jewish merchants are admitted. Much, of course, depends on the individual character of the pasha, but, on the whole, justice is fairly administered, and with less disposition perhaps to press on the non-Muslim portion of the population than in any other city of Asiatic Turkey. The Jewish and Christian communities, indeed, from their wealth, intelligence, and long standing in the country, enjoy an exceptionally favourable social position, and live on terms of equality with their Mahometan neighbours.

Baghdad is also the headquarters of the army of Irak, and regular troops to the amount of five or six thousand men of all arms are usually kept together in the city, while an equal force is distributed in small garrisons in the Arab and Kurdish districts. Baghdad, after paying all its expenses, remits about £100,000 per annum to the imperial treasury, but its resources are capable of almost indefinite development, and there is indeed no reason why the valleys of the Tigris and Euphrates should not, under an enlightened government, yield a revenue fully equal to that of the valley of the Nile.

that period it has remained under a nominal subjection to the Turks. Achmet, the greatest of the pashas of Baghdad, and the first who rendered the pashalic independent of the Porte, defended the town with such courage against Nadir Shah, that the invader was compelled to raise the siege, after suffering great loss. Baghdad, according to Colonel Chesney, had 110,000 inhabitants previously to the great plague of 1830; but in 1853 Mr Layard estimated its population under 50,000. An estimate made in 1872 on a census taken in 1869 rises as high as 150,000, but this is in all probability an exaggeration (v. Allen's *Indian Mail*, 1874). Long 44° 24' E, lat. 36° 21' N. Buckingham's *Travels in Mesopotamia* (1827); Sir R. K. Porter's *Travels in Georgia, Persia, Armenia, and Ancient Babylonia* (1821-22); Kinneir's *Geographical Memoir of the Persian Empire* (1818); Chesney's *Expedition* (1850); Rousseau's *Description de pachalik de Bagdad* (1809); Wellsted's *City of the Caliphs*; Grove's *Residence in Bagdad* (1830-32); *Transactions of Bombay Geog. Soc.* (1856). (H. A. R.)

BAGHERMI, or BAGIRMI, a district or kingdom of Central Africa, lying to the S. of Lake Chad and S.W. of Bornu. It extends about 240 miles from N. to S., and has a breadth of barely 150 miles. The surface is almost flat, with a slight inclination to the N., and the general elevation is about 950 feet above sea-level. The Shari, a large and always navigable river, forms the western boundary, and throws out an important affluent called the Bechikam, which passes through the heart of the country. The soil consists partly of lime and partly of sand, and is by no means unfruitful. In many parts not a stone is to be seen. Negro-millet, sesamum, and sorghum are the principal grains in cultivation, but rice grows wild, and several kinds of grass or *poa* are used as food by the natives. Cotton and indigo are grown to a considerable extent, especially by Bornu immigrants. Among the trees the most important are the tamarind, the deleb-palm, the dum-palm, the hajlij or *Balanites aegyptiaca*, the sycamore, and the cornel. The country often suffers from drought, and is greatly plagued with worms and insects, especially ants of all kinds, red, black, and white. The *Kungunguda*, a sort of beetle which does great damage to the crops, is eaten by the natives. A large proportion of the people have their feet mutilated by the attacks of a small worm, which takes up its residence in the first joint of the little toe and eats it gradually away. The inhabitants of Baghermi are a vigorous, well-formed race, who, according to their own traditions, came from the Far East several centuries ago. They speak a language cognate with those spoken by the Sara, who dwell about two degrees further south, and the Dor, who are situated at the confluence of the Dyor with the White Nile. On their arrival they soon extended their power over the Fellata and Arabs already settled in the district, and after being converted to Mahometanism under Abd-Allah, their fourth king, they extended their authority over a large number of heathen tribes. The most important of these are the Sokoro, the Bus, the Nyillam, the Sara, the Tumok, and the Busso. They are almost all in a low state of civilisation, and practise strange superstitions—a belief in a god whom they identify with thunder being the greatest extent of their religion. They are subject to the barbarous raids of their Baghermian masters, who derive from them a constant supply of slaves with which to pay the tribute demanded from them in their turn by the sultan of Bornu. For our knowledge of this district we are principally indebted to Barth and Nachtigal; the former was for some time a prisoner in Massafia, the capital.

See Barth, *Travels in Northern and Central Africa in 1849-53*, vol. iii., and Nachtigal, in Petermann's *Mittheil.* for 1874, and in *Zeitsch. d. Ges. f. Erdkunde zu Berlin*, 1875.

**BAGHMATI**, a river of Hindustán, which has its source in the hills to the north of Kátmándu, the capital of Népal, whence it flows in a southerly direction through the district of Tirhut in the province of Behar, and, receiving the waters of the Buchá on its north bank, and of Burá Gandak on its south bank, joins the Ganges, after a course of 285 miles, in 25° 23' N. lat. and 86° 34' E. long., about 8 miles below the town of Monghir, but on the opposite bank.

**BAGLIVI**, **GRÓGRO**, an illustrious Italian physician, descended from a poor persecuted Armenian family, was born at Ragusa in 1669, and assumed the name of his adoptive father, Pietro Angelo Baglivi, a wealthy physician of Lecca. He studied successively at the universities of Salerno, Padua, and Bologna; and after travelling over Italy, he went in 1692 to Rome, where, through the influence of the celebrated Malpighi, he was elected professor of anatomy in the college of Sapienza. He died at Rome in 1707, at the early age of thirty-eight. A collection of his writings, which are all in the Latin language, was published in 4to in 1704, and has been several times reprinted in the same form. An edition in 2 vols. 8vo was published in 1788. Baglivi's work *De Fibra Motrice*, is the foundation of that theory of medicine which was substituted by Hoffmann and Cullen for the Humoral Pathology.

**BAGNACAVALLO**, **ΒΑΓΝΑΚΑΒΑΛΛΟ**, an Italian painter, who flourished about the beginning of the 16th century. His real name was Ramenghi, but he received the cognomen Bagnacavallo from the little village where he was born in 1484. He studied first under Francia, and then proceeded to Rome, where he became a pupil of Raffaella. While studying under him he worked along with many others at the decoration of the gallery in the Vatican, though it is not known what portions are his work. On his return to Bologna he quickly took the leading place as an artist, and to him were due the great improvements in the general style of what has been called the Bolognese school. His works were considered to be inferior in point of design to some other productions of the school of Raffaella, but they were distinguished by rich colouring and graceful delineation. They were highly esteemed by Guido and the Carracci, who studied them carefully and in some points imitated them. The best specimens of Bagnacavallo's works, the *Dispute of St Augustin* and a *Madonna with Child*, are at Bologna. He died in 1542.

**BAGNÈRES-DE-BIGORRE** (the *Vicus Aquensis* of the Romans), the capital of an arrondissement in the department of Hautes-Pyrénées, is situated on the left bank of the Adour, 13 miles S.E. of Tarbes. It is one of the principal watering-places in France, and is much admired for its picturesque situation and the beauty of its environs, particularly the valley of Campan, which abounds with beautiful gardens and handsome villas. The town is remarkably neat and clean, and many of the houses are built or ornamented with marble. Its thermal springs and baths are numerous and varied, and are very efficacious in debility of the digestive organs and other maladies. Their temperature is from 90° to 135° Fahr. The season commences in May and terminates about the end of October, during which time the population is more than doubled. Manufactures of woollen cloth, worsted, leather, pottery, and toys are carried on, and marble from the neighbouring quarries is wrought in the town. Greatly frequented by the Romans, and destroyed by the Gothic invaders, Bagnères begins to appear again in history in the 12th century, and rose into permanent importance under the reign of Jeanne d'Albret, the mother of Henry IV. Permanent population, about 9500.

**BAGNÈRES-DE-LUCHON**, a small wall-built town of France, department of Haute-Garonne, pleasantly situated in the valley of the Luchon, at the foot of the Pyrenees.

It is celebrated for its sulphurous thermal springs, which vary in temperature from 88° to 180° Fahr. The bathing establishment is one of the most complete in Europe. The waters are employed with success in a variety of chronic affections, and about 10,000 patients visit the town annually. Resident population, about 3600.

**BAGPIPE** (Fr. *musette*, Ger. *Sackpfeife*, Ital. *cornamusa*), a musical instrument of unknown antiquity, which seems to have been at one time or other in common use among all the nations of Europe, and still retains its place in many Highland districts, such as Calabria, the Tyrol, and the Highlands of Scotland. The wind is generally supplied by a blowpipe, though in some cases bellows are used. These and other slight variations, however, involve no essential difference in character or construction, and a description of the great bagpipe of the Highlands of Scotland will serve to indicate the leading features of the instrument in all its forms. It consists of a large wind-bag made of greased leather covered with woollen cloth; a mouth-tube, valved, by which the bag is inflated with the player's breath; three reed drones; and a reed chanter with finger-holes, on which the tunes are played. Of the three drones, one is long and two are short. The longest is tuned to A, an octave below the lowest A of the chanter, and the two shorter drones are tuned each an octave above the A of the longest drone; or, in other words, in unison with the lowest A of the chanter. The scale of the chanter has a compass of nine notes, all natural, extending from G on the second line of the treble staff up to A in alt. In the music performed upon this instrument, the players introduce among the simple notes of the tune a kind of appoggiatura, consisting of a great number of rapid notes of peculiar embellishment, which they term *warblers*. No exact idea of these *warblers* can be formed except by hearing a first-rate player upon the Highland bagpipe. The history of the bagpipe can be clearly traced from the earliest periods by means of pictorial representations and references occurring in literature. The instrument probably consisted at first of the pipes without the bag, and in this form it is mentioned in Scripture (1 Sam. x. 5; Isa. v. 12; Jer. xlviii. 36), and was used by the Egyptians, the Greeks, and the Romans. The strain upon the player of these pipes was so great that he had to bandage up his lips and cheeks with a *φασβηλα* or *sepiotermum*, the Roman *capistrum*, a leathern muzzle or headstall. It seems very probable that the bagpipe derived its origin from these double and triple reed-pipes, by the after addition to them of a wind-bag made of the skin of a goat or kid, together with a valved *porte-vent*, in order to relieve the strain on the lungs and cheeks of the player. There are several evidences that the bagpipe was well known in the time of Nero. It is represented on a coin of that reign, copied in Montfaucon's *Antiquités*, and Suetonius (*Ner.*, 54) speaks of a promise made by Nero shortly before his death, that he would appear before the people as a bagpiper (*utricularius*). In mediæval Latin the instrument is designated the *Tibia utricularia*. Chaucer represents the miller as skilled in playing the bagpipe; and Shakespeare's familiar allusion to "the drone of a Lincolnshire bagpipe" is sufficient of itself to disprove the common notion that the instrument has always been peculiar to Scotland.

**BAGRATION**, **ΠΑΤΡΗΣ ΠΡΑΨΟΡ**, a distinguished Russian general, descended from the noble Georgian family of the Bagratides, was born in 1765. In 1782 he entered the Russian army and served for some years in the Caucasus. In 1788 he was engaged in the siege of Oczacow, and afterwards accompanied Suwaroff, by whom he was highly esteemed, through all his Italian and Swiss campaigns. He particularly distinguished himself in 1799 by the capture of the town of Brescia. In the wars of 1805 his

achievements were even more brilliant. With a small force he withstood for several hours the united troops of Murat and Lannes, and though half his men fell, the retreat of the main army under Kutusoff was thereby secured. At Austerlitz he had the command of the advanced guard of Prince Lichtenstein's column, and at Eylau and Friedland he fought with the most resolute and stubborn courage. In 1808 he commanded in Finland, and in 1809 in Turkey, and was almost uniformly successful in his operations. In the famous Russian campaign of 1812 the corps under his leadership had been separated from the main army under Barclay de Tolly, and was defeated by Davoust at Mohilev. Begratton, however, succeeded in effecting the

desired junction at Smolenak. He was mortally wounded in the bloody battle of the Borodino, 7th Sept, 1812, and died one month later.

**BAHAMAS**, or **LUCAYAS**, a very numerous group of islands, cays, rocks, and reefs, comprising an area of 3021 square miles, lying between  $21^{\circ} 42'$  and  $27^{\circ} 34'$  N. lat. and  $72^{\circ} 40'$  and  $79^{\circ} 5'$  W. long. They encircle and almost enclose the Gulf of Mexico, stretching more than 600 miles from the eastern coast of Florida to the northern coast of St Domingo, and are traversed by only three navigable channels—1st, the Florida Channel to the N., which runs along the coast of the United States and lies to the westward of the whole Bahama group; 2d, the Providence



Sketch-Map of the Bahama Islands.

Channels, passing through the group to the N., and separating the Great and Little Banks; and 3d, the old Bahama Channel, which passes to the S. of the Great Bahama Bank, between it and Cuba. The islands lie for the most part on the windward edge of the Great and Little Banks, or of the ocean sounds or tongues which pierce them. The total number of islands is 29, while the cays are reckoned at 661, and the rocks at 2387. The principal islands are New Providence (which contains the capital Nassau), Abaco, Harbour Island, Eleuthera, Inagua, Mayaguana, St Salvador, Andros Island, Great Bahama, Ragged Island, Rum Cay, Exuma, Long Island, Crooked Island, Acklin Island, Long Cay, Watling Island, the Berry Islands, and the Bimini. Turk's Island and the Caicos, which belong geographically to the Bahama group, were separated politically in 1848. The formation of all the islands is the same,—calcareous rocks of coral and shell hardened into

limestone, honeycombed and perforated with innumerable cavities, without a trace of primitive or volcanic rock; the surface is as hard as flint, but underneath it gradually softens and furnishes an admirable stone for building, which can be sawn into blocks of any size, these hardening on exposure to the atmosphere. The shores are generally low, the highest hill in the whole range of the islands being only 230 feet high. The soil, although very thin, is very fertile. On Andros Island and on Abaco there is much large timber, including mahogany, mastic, lignum vite, iron, and bullet woods, and many others. Unfortunately the want both of labour and of roads renders it impossible to turn this valuable timber to useful account. The fruits and spices of the Bahamas are very numerous,—the fruit equalling any in the world. The produce of the islands includes tamarinds, olives, oranges, lemons, limes, citrons, pomegranates, pine-apples, figs, sapodillas, bananas, sower-



sops, melons, yams, potatoes, gourds, cucumbers, pepper, cassava, prickly pears, sugar cane, ginger, coffee, indigo, Guinea corn and peas. Tobacco and cascarilla bark also flourish; and cotton is indigenous, and was woven into cloth by the aborigines.

It is a remarkable fact that except in the island of Andros, no streams of running water are to be found in the whole group. The inhabitants derive their water supply from wells, the rain-water in which appears to have some connection with the sea, as the contents of the wells rise and fall with the tide upon the neighbouring shore. The Bahamas are far poorer in their fauna than in their flora. It is said that the aborigines had a breed of dogs which did not bark, and a small coney is also mentioned. The guana also is indigenous to the islands. Oxen, sheep, horses, and other live stock introduced from Europe, thrive well, but of late years very little attention has been paid to stock rearing, and Nassau has been dependent upon Cuba for its beef, and on the United States or Nova Scotia for its mutton. There are many varieties of birds to be found in the woods of the Bahamas; they include flamingoes and the beautiful humming-bird, as well as wild geese, ducks, pigeons, hawks, green parrots, and doves. The waters of the Bahamas swarm with fish, and the turtle procured here is particularly fine. In the southerly islands there are salt ponds of great value.

The story of the Bahamas is a singular one, and bears principally upon the fortunes of New Providence, which, from the fact that it alone possesses a perfectly safe harbour for vessels drawing more than 9 feet, has always been the seat of Government, when it was not the headquarters of lawless villainy. St Salvador (Cat Island, or as some suppose, Watling Island), however, claims historical precedence as the landfall of Columbus on his memorable voyage. He passed through the islands, and in one of his letters to Ferdinand and Isabella he said, "This country excels all others as far as the day surpasses the night in splendour; the natives love their neighbours as themselves; their conversation is the sweetest imaginable; their faces always smiling; and so gentle and so affectionate are they, that I swear to your highness there is not a better people in the world." But the natives, innocent as they appeared, were doomed to utter destruction. Ovando, the governor of Hispaniola, who had exhausted the labour of that island, turned his thoughts to the Bahamas, and in 1509 Ferdinand authorised him to procure labourers from these islands. It is said that reverence and love for their departed relatives was a marked feature in the character of the aborigines, and that the Spaniards made use of this as a bait to trap the unhappy natives. They promised to convey the ignorant savages in their ships to the "heavenly shores," where their departed friends now dwelt, and about 40,000 were transported to Hispaniola to perish miserably in the mines. From that date until after colonisation of New Providence by the English, there is no record of a Spanish visit to the Bahamas, with the exception of the extraordinary cruise of Juan Ponce de Leon, the conqueror of Porto Rico, who passed months searching the islands for "Bimini," which was reported to contain the miraculous "Fountain of Youth."

The deserted islands were first visited by the English in 1629, and a settlement formed in New Providence, which they held till 1641, when the Spaniards expelled them but made no attempt to settle there themselves. The English again took possession in 1667, and in 1680 Charles II. made a grant of the islands to George, Duke of Albemarle; William, Lord Craven; Sir George Carteret; John, Lord Berkeley; Anthony, Lord Ashley; and Sir Peter Colleton. Governors were appointed by the lords proprietors, and there are very copious records in the state papers

of the attempts made to develop the resources of the island; but the repeated attacks of the Spaniards, and the tyranny and mismanagement of the governors, proved great obstacles to success. In July 1703 the French and Spaniards made a descent on New Providence, blew up the fort, spiked the guns, burnt the church, and carried off the governor, with the principal inhabitants, to the Havannah; and in October the Spaniards made a second descent, and completed the work of destruction. It is said that when the last of the governors appointed by the lords proprietors, in ignorance of the Spanish raid, arrived in New Providence, he found the island without an inhabitant. It soon, however, became the resort of pirates, and the names of many of the worst of these ruffians is associated with New Providence, the notorious Blackbeard being chief among the number. At last matters became so intolerable that the merchants of London and Bristol petitioned the Crown to take possession and restore order, and Captain Woods Rogers was sent out as the first Crown governor, and arrived at New Providence in 1718. Many families of good character now settled at the Bahamas, and some progress was made in developing the resources of the colony; although this was interrupted by the tyrannical conduct of some of the governors who succeeded Captain Woods Rogers. At this time the pine-apple was introduced as an article of cultivation at Eleuthera; and a few years subsequently, during the American war of independence, colonists arrived in great numbers, bringing with them wealth and also slave labour. Cotton cultivation was now attempted on a large scale. In 1783, at Long Island, 800 slaves were at work, and nearly 4000 acres of land under cultivation. But the usual bad luck of the Bahamas prevailed; the red bug destroyed the cotton crops in 1788, and again in 1794, and by the year 1800 cotton cultivation was almost abandoned. There were also other causes that tended to retard the progress of the colony. In 1776 Commodore Hopkins, of the American navy, took the island of New Providence; he soon, however, abandoned it as untenable, but in 1782 it was retaken by the Spanish governor of Cuba. The Spaniards retained nominal possession of the Bahamas until 1783, but before peace was notified New Providence was recaptured by a loyalist, Colonel Deveaux, of the South Carolina militia, in June 1783. In 1787, the descendants of the old lords proprietors received each a grant of £2000 in satisfaction of their claims, and the islands were formally reconveyed to the Crown. The Bahamas began again to make a little progress, until the separation of Turks and Caicos Islands in 1848, which had been hitherto the most productive of the salt-producing islands, unfavourably affected the finances. Probably the abolition of the slave-trade in 1834 was not without its effect upon the fortunes of the landed proprietors.

The next event of importance in the history of the Bahamas was the rise of the blockade-running trade, consequent on the closing of the southern ports of America by the Federals in 1861. At the commencement of 1865 this trade was at its highest point. In January and February 1865 no less than 20 steamers arrived at Nassau, importing 14,182 bales of cotton, valued at £554,676. The extraordinary difference between the normal trade of the islands and that due to blockade-running, will be seen by comparing the imports and exports before the closing of the southern ports in 1860 with those of 1864. In the former year the imports were £234,029, and the exports £157,350, while in the latter year the imports were £5,346,112, and the exports, £4,672,398. The excitement, extravagance, and waste existing at Nassau during the days of blockade-running exceed belief. Individuals may have profited largely, but the Bahamas probably

benefited little. The Government managed to pay its debt amounting to £43,786, but crime increased, and sickness became very prevalent. The cessation of the trade was marked, however, by hardly any disturbance; there were no local failures, and in a few months the steamers and their crews departed, and New Providence subsided into its usual state of quietude. This, however, was not fated to last long, for in October 1866 a most violent hurricane passed over the island, injuring the orchards, destroying the fruit-trees, and damaging the sponges, which had proved hitherto a source of profit. The hurricane, too, was followed by repeated droughts, and the inhabitants of the out-islands were reduced to indigence and want. There was an increase, however, in the production of salt. The exports as a whole fell off. Those of native produce, which in 1866 had been £77,604, were reduced in 1867 to £71,117, and the remaining exports of 1866, amounting to £184,372, were, in 1867, £156,131. The depression has continued almost to the present time (1875). The public debt paid off during the days of the blockade-running swelled again to a sum of £54,161, 13s. 2d., and the revenue until very lately was steadily on the decline. It was £47,530 in 1870, while the expenditure was £48,598, and in 1872 there was a further decrease of revenue to £37,574, with an expenditure of £39,000. In 1873 there was, however, an improvement. The revenue rose to £44,053, the expenditure being only £42,737. The improvement in the finances is due principally, it would seem, to the readjustment of the customs' duties. In a recent *Blue Book* it is stated that the Government in 1873 increased the duties on ale, brandy, gin, rum, and whisky by 50 per cent.; on cigars and tobacco, by 100 per cent.; and on wine by 200 per cent. As regards other articles the Assembly at the same time relieved the general consumer by reducing the 25 per cent. *ad valorem* duties to 15 per cent. They abolished the export duty on vessels in distress, and they reduced the tonnage and wharfage dues. They also abolished a licence fee, payable hitherto by the men employed as wreckers, and they repealed a special income-tax levied upon public officers. The last colonial report expresses a hope and a belief that the sound financial condition to which the colony has been restored will continue. The hope, however, hardly seems justified at present by the commercial progress of the Bahamas. In 1870 the imports were of the value of £283,970. In 1872 they had fallen to £201,051, and in 1873 they had increased to £226,306. In like manner the exports of 1873 contrasted favourably with those of 1872, having increased from £136,224 to £156,613. But the increase in exports is due to the development of trade in articles, such as pine-apples and oranges, the production of which is uncertain, since a season's crop may perish in a hurricane. The sponge trade is not so prosperous as it should be, the Spanish authorities, it appears, interfering with the spongers working on the reefs near Cuba; while the excessive duty levied in the United States on salt has almost paralysed the salt-making trade of the Bahamas. The total number of pine-apples exported to the United States and England in 1873 was 422,994 dozen, valued at £38,767. To this must be added the tinned fruit, a branch of industry introduced in 1872. Pine-apples in tins were exported in the following year to the number of 89,165 dozen, valued at £13,018, and cases of pine-apples from the same establishment to the value of £1712. The exportation of other fruit was—of oranges, 2,252,000, valued at £3822; of Bananas, 7172 bunches, valued at £346; and about £700 worth of grape-fruit, shaddock, lemons, limes, and melons. One great and profitable business at the Bahamas has decreased, and is not likely to flourish again. There has

been of late years a marked diminution in the number of marine casualties, which in past times threw into the ports of the colony a large amount of valuable property, of which a great part was frequently exported. The erection of lighthouses, the diversion of trade from the southern ports of America, and the increased use of steam, have all tended to this decline of the wreckers' trade, and it is said that the people of Harbour Island, at one time the great stronghold of the wreckers, have now all turned their attention to the cultivation of pine-apples. In 1864 the number of wrecks reported was, including complete and partial, 67, while in 1871 it was but 39.

The colony is divided into 13 parishes, although the division is now used for civil purposes only. An Act to amend the ecclesiastical laws of the colony was assented to on the 1st of June 1869, and confirmed on the 7th of October 1869, and the Church of England at the Bahamas disestablished. The population of the islands taken at the census of 1871 was 39,162 (being an increase in the decennial period since 1861 of 3875), of whom 19,349 were males, and 19,813 females. With regard to race, it may be said that the native and coloured inhabitants now enormously outnumber the white colonists. The last return showing the varieties of race was published in 1826; the population was 16,033, of whom 4588 were white, 2259 coloured, and 9186 black; since then the proportion of coloured and black to white has increased. The health of the colony has been improving of late years; the death-rate of 1872 was only 17.9 in 1000. The total births were 1475 against 704 deaths. The climate of the Bahamas has always borne a reputation for salubrity. The mean of a series of daily observations of temperature for 10 years is as follows:—

Height of Thermometer in Degrees Fahr. at 9 A.M.

	Max.	Med.	Min.
January .....	75	70	66
February .....	76	71	66
March .....	78	72	66
April .....	81	75	68
May .....	84	78	71
June .....	88	81	74
July .....	88	82	75
August .....	88	81	75
September .....	86	81	75
October .....	82	77	73
November .....	79	74	70
December .....	77	73	69

The rainfall is heavy from May to October. During the winter months it is small, and from the month of November up to April the climate of New Providence is most agreeable. Advantage has been taken of this for many years by the inhabitants of the mainland of America, who can escape by a four days' voyage from the icy winter of New York to the perpetual summer of the Bahamas. New Providence has gained a name as a resort for the consumptive, and perhaps justly so far as the Anglo-Saxon race is concerned, but the Africans and coloured races suffer greatly from diseases of the lungs, and the black troops stationed at Nassau have always been notorious for the proportion of men invalided from consumptive disease. The principal religious denominations are the Wesleyan, Baptist, Church of England, and Presbyterian. The following figures represent approximately the number of persons generally attending the churches and chapels of the several denominations:—Wesleyan, 7370; Baptist, 7971; Church of England, 4250; Presbyterian, 300. There is no Roman Catholic place of worship in the islands, and the members of that church are very few in number. The constitution of the Bahamas consists of a governor, aided by an executive council of 9 members, a legislative council of 9 members,

and a representative assembly of 28 members. The qualifications of electors are full age, a residence of twelve months, six of which must have been as a freeholder, or a residence of six months and a payment of duties to the amount of £26, 0s. 10d. The qualification of members is possession of an estate of real or personal property to the value of £500. The executive is composed partly of official and partly of unofficial members; the latter have usually a seat in one of the branches of the legislature. There are 35 Government schools in the Bahamas, 5 of which are in New Providence, and 30 in the out islands. These schools are managed by an education board composed of 5 or more members, with the governor as president. The legislative grant for educational purposes is £2200 a year, exclusive of the salary of the inspector of schools, who is borne upon the civil establishment on a salary of £200. The number of children on the books is about 3006, and there are 1200 in addition attending schools in connection with the Church of England. It is calculated that about 55 per cent. of the children between 5 and 15 attend school. The isolation of the settlements, the low salaries of the teachers, and the indifference of parents, are great obstacles to the spread of sound education in the Bahamas.

There are numerous lighthouses in the group, the principal being at Gun Cay, Abaco, Cay Sal, Great Isaacks, Cay Lobos, Stirrups Cay, Elbow Cay, Castle Inland, Hoy Inland, and Athol Island. The chief institutions of the Bahamas are to be found in New Providence. They include a savings' bank, a public library, a well-conducted newspaper press, the Agricultural Society, Bahama Institute, Fire Brigade, the New Providence Asylum, Public Dispensary, St Andrew's Charitable Society, a provincial grand lodge of freemasons, &c. There are also libraries at Dunmore Town, in Harbour Island, at Matthew Town, Inagua, at New Plymouth, at Abaco, &c.

(J. T. W. B.)

BAHIA, a province of the Brazilian empire, situated on the S.E. coast, and extending from the Rio Grande do Belmonte in the S. to the Rio Real in the N. It is bounded by Sergipe and Pernambuco on the N., by Piahi on the N.W., by Goyas on the W., and on the S. by Minas Geraes and Espirito Santo. It has an area of 202,273 square miles, and its population is stated at 1,450,000. Bahia sends 14 deputies to the general assembly of the empire, and 7 senators to the upper house, while its own legislative assembly consists of 36 members. Besides Bahia the capital, Olivença, Branca, Jacobina, and Jussara are important towns. A chain of mountains, broken into numerous sierras, runs from N. to S. through the province at the distance of 200 miles from the coast, while the intermediate district gradually rises in successive terraces. The maritime region, the so-called *Recôncavo*, is remarkably fertile, and is studded with thriving towns and villages, but the interior is often very dry and barren, and is only thinly peopled in many places with wandering Botocudos. The main sources of the wealth of the province are cotton, coffee, sugar, and tobacco, all of which are cultivated with the greatest success. Mandioc, rice, beans, and maize are grown; also jalap, ipecacuanha, and saffron, as well as oranges, mangoes, and various other fruits. A large portion is still covered with primeval forest, but the woodman is rapidly diminishing the extent. The mineral wealth of the province is but partially explored and still more partially utilised. In 1844 diamond mines were discovered to the N. of the River Peraguass, and, till the deposits near the Cape of Good Hope were brought to light, afforded employment to a large number of *garimpeiros* or "washers." The discovery of amethysts at Catité in 1872 attracted numerous searchers; and about the same time coal was found in the island of Itaparica. Gold is present in the alluvium of the River San Francisco.

BAHIA, or, in full, SAN SALVADOR DA BAHIA DE TODOS OS SANTOS, a large city, and, till 1763, the capital of Brazil, is situated on the S.E. coast on the Bay of All Saints, from which it takes its name, in 13° S. lat., and 38° 20' W. long. Built partly along the foot and partly on the top of a steep hill, it consists of an upper and lower town, communication between the two being effected by large flights of steps, and since 1873 by a powerful hydraulic elevator. The carrying of goods and passengers up and down these stairway-streets affords employment to a large number of negro porters and chairmen. The lower town, or *Praya*, consists mainly of one long and narrow street, with still narrower and more tortuous lanes. The houses are built of stone, and many of them are several stories high. This is the business part of the city, where are situated the quays, docks, warehouses, custom-houses, exchange, and arsenal; and here the sailors, porters, and lower classes generally reside. The church of *Nostra Senhora da Praya* is remarkable as having been built of stones that were hewn in Lisbon and shipped across the ocean. The upper city has wide and well-paved streets, open squares, and pleasant promenades, adorned with orange trees and bananas. The most important is the *Passeio Publico*, which was opened in 1814, and overlooks the beautiful bay. There is no city in Brazil that can vie with Bahia in the number and splendour of its ecclesiastical buildings, among which the Jesuits' college, now used as a hospital, and the cathedral, which is built of marble, are pre-eminent. There are likewise numerous educational institutions, including a lyceum (in which Latin, Greek, French, and English, mathematics, philosophy, &c., are taught), a theological seminary, and a medical academy, which is supported by the imperial Government, and has about 400 students. The museum and public library also deserve mention. Among the buildings connected with the civic and commercial activity of the city are the government-house, the court-house, the mint, and the town-house; also the *Alfandega*, where all foreign importations have to be entered, and the *Consolado*, where all native productions are registered for exportation. There are likewise a number of banks and commercial associations of various kinds. Bahia has long been a place of great traffic. The streets of the upper city are very inconveniently paved, but the city and its suburbs are now connected by street railways, two running in the upper town and one in the lower. Bomsim is the name of the northern suburb, and Victoria that of the southern; the foreign merchants for the most part reside in the latter. The commerce principally consists in the exportation of cotton, coffee, sugar, rum, tobacco, and rosewood, and the importation of miscellaneous foreign goods. The value of the imports in 1870 was £1,671,676, of which £885,206 belonged to Britain. The exports of the same year were valued at £1,790,928. The bay is one of the finest in America, and is well defended by forts. The entrance is protected by the large island of Itaparica, which has upwards of 16,000 inhabitants, of whom more than 7000 are collected in the town of San Gonzalo. A large number of these are employed in the whale-fishery, which has greatly fallen off, however, from its former prosperity.

Bahia was visited in 1503 by Amerigo Vespucci. The first settlement was founded and called San Salvador by Diego Alvarez Correa, who had been shipwrecked on the coast; but the Portuguese governor who gave formal existence to the city was Thomas de Souza, who landed in 1549. It owed its increase to the Jesuits, who defended it against the English in 1588. In 1623 it fell into the hands of the Dutch, who held it for two years. In 1623 it was surrendered by the Portuguese to the Brazilian nationality. A revolution, which broke out in the city in 1837, was suppressed by the imperial Government. The

first printing-press was introduced in 1811, and the first sugar-mill in 1823. In 1858 railway communication was established to Joazeiro.

**BAHRDT, KARL FRIEDRICH**, a German theologian, distinguished for his extreme rationalism and his erratic life, was born in 1741 at Bischofswerda, of which place his father, afterwards professor of theology at Leipsic, was for some time pastor. He was educated chiefly at the celebrated school of Pforta, and afterwards entered the university of Leipsic, where he studied theology, and at first attached himself to the strongly orthodox party headed by Crusius. After graduation he lectured for a time as adjunct to his father, and then with the rank of catechist proceeded to Leipsic, where he became exceedingly popular as a preacher, and was appointed extraordinary professor of Biblical philology. During this period of his life he published a popular book of devotions, called the *Christian in Solitude*. In 1768 the notorious irregularity of his conduct necessitated his resignation and his departure from Leipsic. By some influence he obtained a professorship of Biblical antiquities in the philosophical faculty of the new university of Erfurt, and having procured a theological degree from Erlangen, he again began to read theological lectures. His orthodoxy had by this time completely vanished; he was an avowed rationalist of the extreme school, and with great diligence and ability sought to popularise the principles of his creed. At the same time his bitter and quarrelsome disposition embroiled him with his colleagues, and in 1771 he left Erfurt, but obtained another professorship at Giessen. Here also the bold expression of his opinions cut short his tenure of office; in 1775 he resigned and became director of Von Salia's educational establishment, the philanthropin at Marschlins, a post he held for only one year. For a brief period he acted as general superintendent at Dürkheim, and then endeavoured, but unsuccessfully, to set up an educational institution at Heidesheim. He had now become most obnoxious to the German Government, who prohibited him from lecturing or publishing any work on theology, or from holding any professorial office. In 1779 he took refuge in Halle, where he resided for ten years, lecturing in the forenoon on moral philosophy, and officiating in the afternoon as landlord of a public-house which he had opened at the gate of the town, and which was largely patronised by the students. In 1789 he was arrested, partly on account of a pasquinade he had written upon the Prussian religious edict, and was condemned to two years' imprisonment. The period of his confinement, reduced by the king to one year, was employed by Bahrüt in writing memorials of his life and opinions. After his release he continued his former course of life, and died after a severe illness, 23d April 1792. His numerous works, including a translation of the New Testament, are comparatively worthless, and are written in an offensive tone. He has been well called by Herzog a caricature of the rationalism of the 18th century.

**BAHREIN**, the principal island of a cluster in the Persian Gulf, in an indentation of the Arabian coast. It is about 70 miles long and nearly 25 broad, and is very flat and low except towards the east, where a range of hills attain an elevation of 800 or 900 feet. The climate is mild, but humid, and rather unhealthy. The soil is for the most part fertile, and produces rice, pot herbs, and fruits, of which the citrons are especially good. Water is abundant, but frequently brackish. Fish of all kinds abound off the coast, and are very cheap in the markets. The inhabitants are a mixed race of Arab, Omanite, and Persian blood, slender and small in their physical appearance; they possess great activity and intelligence, and are known in all the ports of the Persian Gulf for their commercial and industrial ability. The

traffic in the island itself is great and various, the harbour of Manama, which admits vessels of 200 tons, being largely frequented by ships from Persia, Sindh, India, &c. This town, which has in some respects supplanted the older and more inland Ruffin, is well built, and contains about 25,000 inhabitants; and there are besides about 15 villages in the island. There is a city of almost equal extent in the neighbouring and smaller island of Mohanek, but the trade is not so great. Bahrein has from a remote period been famous for its pearl fishery, which produces the finest pearls in the world. The Portuguese obtained possession of the islands in 1507, but were driven from their settlements in that quarter by Shah Abbas in 1622. The islands afterwards became an object of contention between the Persians and Arabs, and at last the Arabian tribe of the Athubis made themselves masters of them in 1784. Since then they have been for some time subject more or less to the Wahabees, whose interference has greatly damaged the commerce of the ports, and led to extensive emigration of the inhabitants. (See Palgrave, in *J. Roy. Geo. Soc.*, vol. xxxiv.)

**BALE**, an ancient town of Campania, Italy, situated between the promontory of Misenum and Puteoli, on the Sinus Baianus, and famous for its warm springs and baths, which served the wealthier Romans for the purposes both of health and pleasure. The variety of these baths, the mildness of the climate, and the beauty of the landscape, captivated the minds of the opulent nobles. The habitations at first were small and modest; but increasing luxury added palace to palace, and enterprising architects, supported by boundless wealth, laid the foundations of new erections in the sea. From being a place of occasional resort for a season, Bais grew up into a city, and the confluence of wealthy inhabitants rendered it as much a miracle of art as it had before been of nature, though it never attained the rank of a *municipium*, but continued to be dependent on Cumæ. C. Marius, Lucullus, Pompey, and Julius Cæsar are among the most remarkable of those who gave éclat to Bais during the republic; and at a later period it was a favourite resort of Nero, Caligula, Hadrian, and Severus. It flourished till the days of Theodoric the Goth; but its destruction followed quickly upon the irruption of the northern conquerors. When the guardian hand of man was withdrawn, the sea reclaimed its old domain; moles and buttresses were washed away; and promontories, with the proud towers that once crowned their brows, were undermined and tumbled into the deep. Innumerable ruins, heaps of marble, mosaics, and other relics of the past, attest the ancient splendour of the city. The most remarkable are the so-called temples of Mercury, Venus, and Diana, and various buildings which, rightly or wrongly, have been assigned to the more famous of those who are known to have had villas in the town. The *Castello di Baja* was built in the 16th century by Pietro di Toledo. Long. 14° 3' E, lat. 40° 50' N.

**BAIBURT**, a town of Asiatic Turkey, in the pashalic of Erzeroum, and 65 miles W.N.W. from that city. According to Neumann it was an Armenian fortress in the 1st century, and it is identified by Ritter with the *Baiberdon* fortified by Justinian. It was afterwards one of the strongholds of the Genese, when prosecuting their trade with India. Remains of their fortifications still exist, but in a very dilapidated state, the Russians having blown up the defences in 1829. (See view in Yule's *Marco Polo*, vol. i.) Population of town about 6000.

**BAIF, JEAN ANTOINE** DE, poet of the French Renaissance and member of the Pleiad, was the natural son of Lazare de Balf and an Italian girl. He was born in 1532 at Venice, where his father was residing as French ambassador. Thanks, perhaps, to the surroundings of his childhood, he

grew up a fanatic for the fine arts, and surpassed in zeal all the leaders of the Renaissance in France. Besides writing an immense number of short poems of an amorous or congratulatory kind, he translated or paraphrased various pieces from Bion, Moschus, Theocritus, Anacreon, Catullus, and Martial. He resided in Paris, enjoyed the continued favour of the court, and founded the Académie Royale de Musique; his house became famous for the charming concerts which he gave, entertainments at which Charles IX. and Henry III. frequently flattered him with their presence. He was a dear friend of Ronsard and the other members of the Pleiad. His works were published in 4 thick volumes, entitled *Amours, Jeux, Passe-temps, et Poèmes* (1571-74), containing, among much that is now hardly readable, some pieces of infinite grace and delicacy. He died in 1589 or 1591. His father, Lazare de Baif, published a translation of the *Electra* of Sophocles in 1537, and afterwards a version of the *Heubea*, was an elegant versifier in Latin, and is commended by Joachim du Bellay as having introduced certain valuable words into the French language.

**BAIKAL** (i.e., *Baikal*, or Abundant Water), a great fresh-water lake of Siberia, in the government of Irkutsk, 397 miles in length from S.W. to N.E., and from 13 to 54 miles in breadth, with an area of about 12,500 square miles. This vast reservoir is situated 1360 feet above the level of the sea, in the midst of steep mountain ranges, that often rise sheer from the water's edge in lofty walls of gneiss, granite, or conglomerate, while elsewhere their sloping flanks are thickly clad with dark forests of coniferous trees. The lake is fed by several rivers,—the Upper Angara, the Selenga, which descends from the basin of Lake Koesogol, the Barguzin, and others; while the only visible outlet is by the Lower Angara, a tributary of the Yenisei. The water is excellent, and is extremely clear, so that the bottom can be seen at the depth of 8 fathoms. The depth of the lake varies from 22 to upwards of 300 fathoms. It yields abundance of salmon, and there is a profitable fishery of seals on its shores during the whole summer. The climate is extremely severe; and the lake, which is frozen over from November to May, is almost perpetually swept by the wind. It facilitates, however, the Russian trade with China, and that between Irkutsk and Dauria. It is navigated by the Russians in summer, and in winter they cross it on the ice. Europeans embarked on its waters for the first time in 1643. Steam-vessels were introduced in 1846, and the passage across is made in about eight hours. Several hot springs and mineral waters are seen on the margin, and naphtha is sometimes found floating on the surface. The lake is between 51° 20' and 55° 30' N. lat., and 103° and 110° E. long. The island of Olkhon, near its north shore, is 32 miles long and nearly 10 broad. This island and the southern borders of the lake are inhabited by Mongolian tribes, while towards the north the Tunguses are to be found in gradually diminishing numbers. (See "Description du lac de Baikal," trad. du russe par M. Klapproth, in *Nouv. Ann. des Voy.* t. xvii. p. 289; Erman's *Siberia*, 1848; Semenov, *Slovar Ross. Imp.*)

**BAIKIE**, WILLIAM BALFOUR, M.D., eldest son of Captain John Baikie, R.N., was born at Kirkwall, Orkney, on the 21st August 1824. He studied at Edinburgh, and, on obtaining his degree, joined the royal navy. He early attracted the notice of Sir Roderick Murchison, through whom he was appointed surgeon and naturalist to the Niger Expedition of 1854. The death of the senior officer occurring at Fernando Po, Dr Baikie succeeded to the command. The results of the voyage are given in his own and other narratives. Ascending the river about 250 miles beyond the point reached by former explorers, the

little steamer *Pleiad* returned and reached the mouth after a voyage of 118 days without the loss of a single man. The second expedition started in March 1857. After two years passed in exploring, the navigating vessel was wrecked in passing through some of the rapids of the river, and Dr Baikie was unable longer to keep his party together. All returned home but himself; no way daunted, he determined single-handed to carry out the purposes of the expedition. Landing from a small boat with one or two native followers at the confluence of the Quorra and Benue, he here chose the old model farm ground as the base of his future operations—a spot memorable from the disasters of the exploring party of 1841. After purchasing the site, and concluding a treaty with the native chief, he proceeded to clear the ground, build houses, form enclosures, and pave the way for a future city. Numbers flocked to him from all parts round, and in his settlement were representatives of almost all the tribes of Central Africa. To the motley commonwealth thus formed he acted not merely as ruler, but also as physician, teacher, and priest. Before five years he had opened up the navigation of the Niger, made roads, and established a market, to which the native produce was brought for sale and barter. He had also collected vocabularies of nearly fifty African dialects, and translated portions of the Bible and prayer-book into Housa. Once only during his residence had he to employ armed force against the surrounding tribes. He died on his way home, at Sierra Leone, in November 1863, aged thirty-nine years. An appropriate monument has been erected to his memory within the nave of the ancient cathedral of St Magnus.

**BAIL** (*Ballium*) is used in common law for the freeing or setting at liberty of one arrested or imprisoned upon any action, either civil or criminal, on surety taken for his appearance at a certain day and place.

**BAILLEN**, a town of Spain, in the province of Jaen, 24 miles N.N.W. of Jaen. It seems to correspond to the ancient *Bœcula*, where Scipio gained signal victories over Hasdrubal, 209 a.c., and over Mago and Masinissa, 206 a.c. (Polyb., x. 38, xi. 20; Liv., xxvii. 18-20, xxviii. 13). In the neighbourhood also, in 1212, was fought the great battle of Navas de Tolosa, where Alphonso VIII. is said to have left 200,000 Moors dead on the field, with the loss of only 25 Christians. Here again, on the 23d of July 1808, the French general Dupont, after a bloody contest of several days, signed the capitulation of Bailen, by which 17,000 men were delivered up to the Spaniards as prisoners of war. This disaster was the first great blow to the French arms in the Peninsula. There is nothing remarkable about the town, except the ruins of a castle, formerly belonging to the counts of Banavente, and now the property of the Osuna family. Glass and tiles are manufactured, and the weaving of cloth and pressing of olives are carried on. Population, 7831. (Mados, *Diccionario*; Ukert. vol. x. p. 379.)

**BAILEY**, or **BAILY**, NATHANIEL or NATHAN, an eminent English philologist and lexicographer, whose *Etymological English Dictionary*, published apparently in 1721, was a great improvement on all previous vocabularies, and really formed the basis of Johnson's great work. It is still worthy of being consulted for information with regard to the change of signification in certain words, and to the date at which others were introduced into the language. Bailey had a school at Stepney, near London, and was the author of *Dictionarium Domesticum* and several other educational works. He died in 1742.

**BAILEY**, SAMUEL, an able writer on philosophical and literary subjects, was born at Sheffield in 1791. His father carried on a large general business in that town, and for some years the son devoted himself to mercantile pur-

suits. It was not long, however, before he gave up this occupation, and, having a competent fortune, withdrew from all business concerns, with the exception of the Sheffield Banking Company, of which he was chairman for many years. Although an ardent Liberal of most advanced views, he took little or no active part in political affairs. On two occasions, at the earnest solicitation of his numerous friends and admirers, he stood for Sheffield, but without success. The "Bentham of Hallamshire," as he has been called, was of too retiring a disposition, and had too much of the philosophical politician about him to win the admiration or suffrages of an ordinary body of electors. His life is for the most part a history of his numerous and varied publications, and his name is known to a very limited circle. The intimation of his sudden death on the 18th January 1870, with the subsequent notice of his munificent gift of £90,000 to his native town, excited some curiosity and interest, which, however, quickly died away. This is not quite as it should be. Bailey has certainly given to the world no work of first-rate importance, but there are few authors of modern times who have written more elegantly and clearly, or with more originality of treatment, on the various problems of psychology and political science. His first work, *Essays on the Formation and Publication of Opinions*, published anonymously in 1821 (2d ed. 1826, 3d ed. 1837), a thoughtful, practical, and clearly written treatise, has attracted a greater share of public attention and favour than any of his other writings. A sequel to it appeared in 1829, *Essays on the Pursuit of Truth, on the Progress of Knowledge, and on the Fundamental Principles of all Evidence and Expectation* (2d ed. 1844). Intermediate between these two were *Questions on Political Economy, Politics, Morals, &c.*, 1823, and a *Critical Dissertation on the Nature, Measure, and Causes of Value*, directed against the opinions of Ricardo and his school. His next publications were also on economic or political subjects, *Rationals of Political Representation*, 1835, and *Money and its Vicissitudes*, 1837; about the same time also appeared some of his pamphlets, *Discussion of Parliamentary Reform, Right of Primogeniture Examined, Defence of Joint-Stock Banks*. Bailey seems then to have turned his attention almost entirely to speculative philosophy. In 1842 appeared his *Review of Berkeley's Theory of Vision*, an acute and able work, which called forth rejoinders from J. S. Mill in the *Westminster Review* (reprinted in *Dissertations*), and from Ferrier in *Blackwood* (reprinted in *Lectures and Remains*, ii). Bailey replied to his critics in *A Letter to a Philosopher, &c.*, 1843. In 1851 he published one of his best works, *Theory of Reasoning* (2d ed. 1852), a thoughtful discussion of the nature of inference, and an able criticism of the functions and value of the syllogism. In 1852 he published *Discourses on Various Subjects*; and finally summed up his philosophic views in the *Letters on the Philosophy of the Human Mind* (three series, 1855, 1858, 1863), which is at once the most considerable and the most valuable of his contributions to mental science. Bailey had not entirely given himself up to abstract studies; in 1845 he had ventured on poetical composition. *Marc*, a poem in four cantos (85 pp., Longmans), contains a somewhat lively description of the mental state of a young poet who printed 1000 copies of his first poem, of which only 10 were sold. He had also been a diligent student of Shakespeare, and his last literary work was the treatise, in two volumes, *On the Received Text of Shakespeare's Dramatic Writings and its Improvement*. It must be confessed that many of the emendations suggested by him are more fantastic than felicitous.

The *Letters* contain, in clear and lively language, a very fresh discussion of many of the principal problems in philosophy, or rather in psychology. Bailey can hardly be

classed as belonging either to the strictly empirical or to the idealist school, but his general tendency is towards the former. The following are the most interesting points in his work:—(1.) In regard to method, he founds psychology entirely on introspection; critical study of one's own consciousness is, according to him, the only means of obtaining materials for philosophy. He thus, to a certain extent, agrees with the Scotch school, but he differs from them in rejecting altogether the doctrine of mental faculties. What have been designated faculties are, upon his view, merely classified facts or phenomena of consciousness. He criticises very severely the habitual use of figurative or metaphorical language in describing mental operations. (2.) His doctrine of perception, which is, in brief, that "the perception of external things through the organs of sense is a direct mental act or phenomenon of consciousness not susceptible of being resolved into anything else," and the reality of which can be neither proved nor disproved, is not worked out in detail, but is supported by elaborate and sometimes subtle criticisms of all other theories. Upon this point Bailey's remarks are deserving of attention. (3.) With regard to general and abstract ideas and general propositions, his opinions are those of the empirical school, but his analysis frequently puts the matter in a new light, and brings forward points of novelty. (4.) In the theory of morals Bailey is an advocate of Utilitarianism, and works out with great skill the steps in the formation of the "complex" mental facts involved in the recognition of duty, obligation, right. His handling of the moral sentiments (*Letters*, iii. 193–258) is one of the best specimens of his general style of psychological analysis.

BAILLET, ADRIEN, a French writer and critic, was born in June 1649, at the village of Neuville, near Beauvais, in Picardy, and died in January 1706. His parents could only afford to send him to a small school in the village, but he picked up some Latin from the friars of a neighbouring convent, who brought him under the notice of the bishop of Beauvais. By his kindness Baillet received a thorough education at the theological seminary, and was afterwards appointed to a post as teacher in the school of Beauvais. In 1676 he took orders, and was presented to a small vicarage. His duties interfering too much with his studies, he accepted in 1680 the appointment of librarian to M. de Lamoignon, advocate-general to the parliament of Paris, of whose library he made a *Catalogue Raisonné* in thirty-five volumes folio, all written with his own hand. The remainder of his life was spent in incessant, unremitting labour; so keen was his devotion to study that he scarcely allowed himself even natural rest. In the list of his numerous works the following are among the most conspicuous:—1. *Histoire de Hollande depuis 1609 jusqu'à 1690*, 4 tom. 12mo, a continuation of *Grotius*, and published under the name of Neuville. 2. *Les Vies des Saints*, 3 tom. fol. 3. *Des Satires personnelles, traits historiques et critiques de celles qui portent le titre d'Anti*, 2 tom. 12mo. 4. *Vie de Descartes*, 2 tom. 4to. 5. *Jugemens des Savants sur les principaux Ouvrages des Auteurs*, 9 tom. 12mo. The last is the most celebrated and useful of all the works of this learned and indefatigable writer. The edition in seven volumes quarto, published in 1722 by M. de la Monnoye, contains the *Anti-Baillet* of M. Menage, besides notes; but the edition published at Amsterdam in 1725 is more esteemed.

BAILLEUL, an ancient town of France, in the department of Nord, near the Belgian frontier, situated on a rising ground to the north of the River Lyr. It was formerly a place of great strength, and is now a busy industrial town, with manufactures of lace, thread, black soap, pottery, woollen stuffs and ribbons, brandy, leather, and cheese. Population, 12,896. Lat. 50° 45' N., long. 2° 44' E.

**BAILLIE, JOANNA**, poet and dramatist, was born at the manse of Bothwell, on the banks of the Clyde (Scotland), in 1762. At an early period of her life she removed with her sister Agnes to London, where their brother, the celebrated Dr Matthew Baillie, was settled. The two sisters were left a small competence by their uncle, Dr William Hunter, and took up their residence at Hampstead, on the outskirts of London, where they passed the remainder of their lives. Miss Baillie died on the 23d Feb. 1851, at the advanced age of 89, her faculties remaining unimpaired to the last. Her gentleness and sweetness of disposition made her a universal favourite, and her little cottage at Hampstead was the centre of a brilliant literary society. Miss Baillie had received an excellent education, and probably cultivated very early her faculty of poetical composition, but it was not till 1798 that she published the first volume of her *Plays on the Passions*. Her design, founded on a careful study of the nature of dramatic poetry, was to illustrate each of the deepest and strongest passions of the human mind, such as Hate, Jealousy, Fear, Love, by a tragedy and a comedy, in each of which should be exhibited the actions of an individual under the influence of these passions. The success of the first volume was very considerable, and a second edition was soon called for. A second volume followed in 1802, a third in 1812, and three more in 1836. Some miscellaneous dramas were published in 1804, and the *Family Legend* appeared in 1810. Miss Baillie herself intended her plays not for the closet but for the stage. The *Family Legend*, brought out at Edinburgh under the enthusiastic patronage of Sir Walter Scott, had a brief though brilliant success; *De Monfort* had a short run in London, mainly through the acting of Kemble and Mrs Siddons; *Henriques* and *The Separation* were coldly received. The popular verdict has thus been given against the dramas as good stage plays, and the almost universal decision of readers has confirmed this judgment. With very few exceptions, they are unsuited for stage exhibition. Not only is there a flaw in the fundamental idea, that, viz., of an individual who is the embodiment of a single passion, but there is a want of incident, and a narrowness, consequent upon the attention being too much directed on a single point, that present insuperable obstacles to their success as acting pieces. The plot is generally well constructed, but the very consciousness of aim with which it is wrought out gives to the whole a morbid and unnatural aspect; there is rarely, if ever, any progress in the play; the whole is apparent from the outset, and the action never heightens the spectators' interest. It must be confessed, also, that Miss Baillie had no very adequate notion of what is required in a stage drama, and that her experience was too limited. This is apparent in her comedies, which are very inferior productions. In short, her want of success is a clear proof of the impracticability of that analytic or psychological method, which she expounds and defends in her preliminary dissertations. The plays, however, are admirably adapted for reading; they show remarkable powers of analysis and acute observation, and are written in a pure and vigorous style, rising occasionally into strains of high poetic feeling and expression. The best of the tragedies are undoubtedly *Henriques*, *The Separation*, *De Monfort*, and *Count Basil*, the first of which might perhaps be made into a good acting play. Miss Baillie's reputation does not rest entirely on her dramas: she is the authoress of some poetical pieces and songs of great beauty, and in all probability great portion of her fame will be found to rest on these minor works. The best of them are the *Lines to Agnes Baillie on her Birthday*, *The Kitten*, *To a Child*, and some of her adaptations of Scotch songs, such as *Wood and Married an' a'*. Scattered throughout the dramas are also some lively and

beautiful songs, such, e.g., as the *Though and the Crow* in *Orra*, the lover's song in the *Phantom*, beginning—

"I've seen the moon gleam through the cave,  
And minute drops like diamonds glancing."

And the sailor's song—

"O swiftly glides the bonny boat  
Just parted from the shore."

(See Joanna Baillie's *Dramatic and Poetical Works*, Lond. 1851, 1 vol.)

**BAILLIE, DR MATTHEW**, anatomist and physician, was born in the manse of Shotts, Lanarkshire, in 1761. He came of a highly gifted family: his father, the Rev. James Baillie, was successively clergyman of the parishes of Shotts, Bothwell, and Hamilton, in Lanarkshire, and afterwards professor of divinity in the university of Glasgow; his mother was Dorothea, sister of the celebrated William and John Hunter; and his sister Joanna was the poet. Dr Baillie was for several years a student in the university of Glasgow, where he heard the lectures of Dr Reid on moral philosophy. His professional career was determined by the advice of his uncle, Dr William Hunter, who undertook to superintend his education. On his father's death he obtained an exhibition to Balliol College, Oxford, where he remained a year before removing to London. His studies were there carried on under the personal direction of his uncle, and after two years he began to be associated with Dr Hunter in his anatomical lectures as an assistant and demonstrator, visiting Oxford occasionally, so as to keep the terms necessary for the degree of bachelor of medicine. Dr Hunter, at his death, bequeathed the use of his magnificent collections to his nephew, together with the lecture-rooms in Windmill Street, an annuity of £100 a year, and a small family estate in Scotland. The last was resigned by Baillie to his other uncle, Dr John Hunter, whom he considered as the natural heir. Within two years after Dr Hunter's death his nephew became the principal teacher in that celebrated school of anatomy; and in 1787, although only a bachelor of medicine, he was appointed physician to St George's Hospital. In 1789 he married Sophia, daughter of the eminent accoucheur Dr Denman, a connection favourable to his practice. In 1795 he published his *Morbid Anatomy*, a work which was speedily translated into French, Italian, and German, into the last by the anatomist Sömmerring. After this he had the honour of being enrolled a doctor of medicine of Oxford, and Fellow of the Royal College of Physicians. As a practising physician he was universally respected, and his decease, which took place on the 23d of September 1823, in the 63d year of his age, was sincerely regretted.

The second edition of the *Morbid Anatomy* appeared in 1797; and two years afterwards it was illustrated by a 4to volume of engravings, with descriptions of the plates. His *Anatomical Lectures and Medical Observations* were printed privately after his death. *The Works*, 2 vols. 8vo, edited, with a biographical sketch, by Mr Wardrop, contain only the *Morbid Anatomy* and miscellaneous medical papers.

**BAILLIE, ROBERT**, a prominent Scotch Presbyterian of the 17th century, was born at Glasgow in 1602. He graduated in 1620 at the university of that town, and then applied himself to the study of divinity. In 1631, after he had been ordained and had acted for some years as regent in the university, he was appointed to the living of Kilwinning in Ayrshire. The church disputes of the century were just beginning, and Baillie was naturally drawn into them. In 1638 he was a member of the famous Glasgow Assembly, and soon after he accompanied Leslie and the Scotch army as chaplain or preacher. In 1642 he was made professor of divinity at Glasgow, and in the following year was selected as one of the five Scotch

clergymen who were sent to the great Westminster Assembly. In 1649 he was one of the commissioners sent to Holland for the purpose of inviting Charles II. to Scotland, and of settling the terms of his admission to the government. He continued to take an active part in all the minor disputes of the church, and in 1661, after the ejection of Gillespie, he was made principal of the Glasgow University. He died in August of the following year,—his death being probably hastened by his mortification at the apparently firm establishment of Episcopacy in Scotland. Baillie was a man of learning and ability; his views were not extreme, and he played but a secondary part in the stirring events of the time. His *Letters*, by which he is now chiefly remembered, are of considerable historical importance, and give a very lively picture of the period. A complete memoir and a full notice of all his writings will be found in Dr Laing's edition of the *Letters and Journals of Robert Baillie*, Bannatyne Club, 3 vols., Edinburgh, 1841-42.

BAILLY, JEAN SYLVAIN, a French astronomer and orator, was born at Paris on the 15th September 1736. He was originally intended for the profession of a painter; his own inclinations, however, tended strongly towards literary pursuits, and it is said that at a very early age he had completed two tragedies. But his acquaintance and friendship with the celebrated mathematician Lacleille, and perhaps the example of his brilliant young contemporary Clairaut, finally decided the direction of his studies, which were then entirely devoted to science and scientific investigation. The first of his labours was a calculation of the comet which appeared in the year 1759. In 1763 he was admitted a member of the Academy of Sciences; and in the same year he published a reduction of the observations made by Lacleille in 1760 and 1761 on the zodiacal stars, a compilation of great labour and utility. In 1764 he competed for the prize offered by the Academy for a dissertation on the theory of Jupiter's satellites. Lagrange, who was a complete master of the most powerful analysis, was the successful competitor; but Bailly's memoir, which was published in an expanded form in 1766, showed great ability, and at once established the author's reputation as a physical astronomer. He followed up his dissertation in 1771 with an able and important memoir on the *Light of the Satellites*, in which he expounded some novel and elegant methods of observation.

His attention, meantime, was not solely devoted to abstract science; he was equally distinguished for eloquence and brilliancy of style. His *Eloges* on Corneille, Leibnitz, Molière, and others, were universally admired. In 1773 he was proposed as a candidate for the secretaryship of the Academy of Sciences, and was supported by Buffon; the influence of D'Alembert, however, secured the appointment of the famous Condorcet. In 1784 Bailly was made secretary of the French Academy, and in the following year he was admitted to the Academy of Inscriptions and Belles Lettres. This was the only instance, from the time of Fontenelle, of any writer being at the same time a member of all the three academies.

In the year 1775 he published the first volume of his most extensive work, *History of Astronomy*, which contained the history from its origin down to the foundation of the Alexandrian school. This was followed by three volumes on *Modern Astronomy*, published between 1776 and 1783. The work is of little or no historical value, but it is admirably written, and added greatly to the author's reputation as a master of narrative exposition. In 1787 he completed the history by a volume on Indian and Oriental astronomy, which shows considerable erudition, but is not founded on a complete knowledge of the Indian records, and is highly fantastic in its speculations.

The quiet course of Bailly's life, hitherto devoted to literature and science, was now broken in upon by that great convulsion, the French Revolution, of which he was one of the first and most zealous promoters. In the part which he acted, he has had the singular good fortune to be well spoken of by opposite factions, and has never been charged either with want of integrity or with selfish designs. When the states-general of France were assembled in 1789, he was elected a deputy to the *tiers-état*, of which he was afterwards chosen president; and when the national assembly had been constituted, he continued in the chair, and officiated as president at the time the king's proclamation was issued ordering that body to disperse. During the struggle which took place between the national assembly and the court, Bailly was amongst the most forward in asserting those popular rights which were then new in France; and it was he who dictated the famous oath to the members of the *tiers-état*, by which they pledged themselves "to resist tyrants and tyranny, and never to separate till they had obtained a free constitution." On the 14th of July following, the day on which the Bastille was stormed and taken by the people, he was by universal consent appointed mayor of Paris. In this high office he is allowed to have acted with great integrity, courage, and moderation, and to have discharged its arduous and sometimes perilous duties in a highly honourable manner, and during its course he was instrumental in promoting the various measures by which the popular party at length prevailed over that of the court; for which, as well as for his conduct in other respects, he obtained a high degree of popularity. But the multitude, newly unshackled from the fetters of despotism, greedy of novelty, fired with enthusiastic and unsettled notions of freedom, and daily panting for change, would brook no opposition to their wild schemes. Bailly, who probably saw too late the general disposition of the people to anarchy, still wished the laws to be respected, and hoped by the vigorous enforcement of them to restore and maintain tranquillity. He ordered some deputies from the military insurgents of Nancy to be arrested, and firmly opposed the rash proceedings of Marat and Hebert; he ceased to be a member of the Jacobin club; and he exerted himself strongly to persuade the populace to permit the king and royal family to depart to St Cloud. By these measures, which were very distasteful to the fickle and infuriated people, he lost their confidence and favour; and his popularity was finally destroyed by his conduct on the occasion of the tumultuous meeting of the populace on the 17th of July 1791, to demand the abolition of monarchy; for, when called on by the national assembly to disperse the mob, who had assaulted the soldiery, he ordered the latter to fire, by which means 40 persons were killed and above 100 wounded. Finding himself after this an object of hatred and suspicion to the people, whom he had faithfully served, he resigned his office at the dissolution of the constituent assembly in the end of the year 1791, and retired to Nantes. From there he wrote to Laplace, who was residing at Melun, and proposed, if it were safe, to join him. Laplace, finding that a detachment of revolutionary troops had been ordered to Melun, advised Bailly not to venture, but his advice was neglected. The ex-mayor was recognised by one of the soldiers, arrested, and thrown into prison. Arraigned on 10th November 1793 before a sanguinary tribunal, he was on the 11th condemned to death as a conspirator, and executed the day following, near the spot where he had given the order for the military to fire on the people. He met his death with the greatest calmness and courage.

Several works written by Bailly, and found in manuscript, have been published since his death; particularly an *Essay on Politics and their History*, and *Memoirs of a Witness of the Revolution*.



which come down to October 1789. Notices of his life are given in the *Stages* by St Just, Lalande, and Lacrèlle; also in Arago, *Notices Biographiques*, vol. ii.

**BAILY, EDWARD HODGES**, a distinguished sculptor, was born at Bristol, 10th March 1788, and died at London, 23d May 1867. His father, who was a ship-carver of great repute, destined him for a commercial life, but even at school the boy showed his natural taste and remarkable talents by producing numerous wax models and busts of his schoolfellows, and afterwards, when placed in a mercantile house, still carried on his favourite employment. Two Homeric studies, executed for a friend, were shown to Flaxman, who bestowed on them such high commendation, that in 1807 Baily came to London and placed himself as a pupil under the great sculptor. In 1811 he gained the Academy gold medal for a model of *Hercules restoring Alceste to Admetus*, and soon after exhibited *Apollo discharging his arrows against the Greeks*, and *Hercules casting Lichas into the sea*. In 1821 he was elected R.A., and exhibited one of his best pieces, *Ev.* He was for many years engaged in lucrative employment as modeller for Messrs Rundell & Co. and Messrs Storr & Mortimer. He was also entrusted with the carving of the bas-reliefs on the south side of the Marble Arch at Hyde Park. Besides numerous busts and statues such as those of Nelson on the Monument, of Earl Grey, of Lord Mansfield, and others, his finest pieces are *Eve at the Fountain*, *Eve listening to the Voice*, *Maternal Affection*, *Girl preparing for the Bath*, and the *Graces*.

**BAILY, FRANCIS**, an English astronomer, was born in Berkshire in the year 1774, and for many years carried on business as a stockbroker in London. While amassing a large fortune by his business, he applied the profound mathematical knowledge for which he was distinguished to the doctrine of probabilities, and published several interesting works on that subject, as, *Tables for the Purchasing and Renewing of Leases*, *The Doctrine of Interest and Annuities*, *The Doctrine of Annuities and Assurances*, &c. In 1820 he was one of the original and most active promoters of the Astronomical Society; and on his retirement from business in 1825, he entered with the utmost energy upon the cultivation of astronomy and the kindred sciences. He gave the *Nautical Almanac* its present form and introduced other improvements; he took an active part in the investigation of the effects of the atmosphere on pendulum experiments; he aided in the repetition of the experiment of Cavendish on the specific gravity of the earth; he superintended the publication of the Astronomical Society's catalogue of the fixed stars; and the revision of the annual catalogues in the 13th volume of the Society's *Memoirs* was entirely his work. On his recommendation the British Association undertook the republication of the *Histoire Céleste* of Lalande, combined with Lacaille's catalogue, which together contain no less than 57,000 stars; and there is reason to believe that he took an important part in the investigation of the course of the tidal wave in the Atlantic. His *Account of the Rev. John Flamsteed, First Astronomer-Royal*, 1835, a work of great ability and research, excited much discussion from the disclosures it made relative to the character of Sir Isaac Newton. Baily was extremely patient and methodical, and these qualities enabled him to effect, in the last twenty years of his career, a greater number of researches than most other philosophers have accomplished during a whole lifetime. He died August 30, 1844.

**BAINBRIDGE, DR JOHN**, physician and astronomer, was born at Ashby-de-la-Zouch, in Leicestershire, in the year 1582. He taught a grammar school for some years, and practised physic, employing his leisure hours in astronomy, which was his favourite study. After removing

to London he was admitted a Fellow of the College of Physicians, and gained considerable reputation by his description of the comet in 1618. The next year Sir Henry Savile appointed Bainbridge his first professor of astronomy at Oxford; and the masters and fellows of Merton College made him first junior, and then superior, reader of Lincæ's lecture. He died in 1643. His published works are—1. *An Astronomical Description of the late Comet*, Lond. 1619. 2. *Proeli Sphæra*, 1620. 3. *Canicularia; a Treatise concerning the Canicular Days*, Oxford, 1648. Several of his unpublished writings exist in manuscript in the library of Trinity College, Dublin.

**BAINES, EDWARD**, for many years proprietor and editor of the *Leeds Mercury*, and M.P. for Leeds from 1834 to 1841, was born in 1774 at Walton-le-Dale, a village distant a little way from Preston, in Lancashire. He was educated at the grammar schools of Hawkshead and Preston, and at the age of sixteen was apprenticed to a printer in the latter town. After remaining there four years and a half he removed to Leeds, finished his apprenticeship, and at once started in business for himself. He was always a most assiduous student, and quickly became known as a man of great practical shrewdness and ability, who took a keen interest in political and social movements. His liberal opinions in politics led him to sympathise with the dissenting party in church affairs, and it was not long before he joined the body of Independents. In 1801 the assistance of friends among the members of that party enabled him to purchase the copyright of the *Leeds Mercury*. Provincial newspapers did not at that time possess much influence; the editorial province was not extended to the composition of what are now called leading articles, and the system of reporting was defective. In both respects Baines made a complete change in the *Mercury*. The ability of his political articles gradually caused the paper to be looked upon as the organ of Liberal opinion in Leeds, and it contributed not a little to the spread of sound doctrines on practical questions in the north of England. At the same time his watchful care secured the efficiency of the minor departments. Baines soon began to take a more prominent part in politics; he was an ardent advocate of parliamentary reform, and it was mainly by his influence that Macaulay was returned for Leeds in 1832. In 1834, when a vacancy was caused by Macaulay's acceptance of an Indian appointment, Baines was proposed as a candidate, and was returned after a sharp contest. He was re-elected in 1835 and 1837, but was obliged to resign from ill health in 1841. He was noted in Parliament as a judicious supporter of the Liberal party, but with independent views. He strongly advocated the separation of church and state, and opposed Government interference in national education. His letters to Lord John Russell on the latter question (1846) had a powerful influence in determining the action of the Government. He died in 1848. In the midst of his active life he had found time for literary work. His best known writings are:—*The History, Directory, and Gazetteer of the County of York*; *History, Directory, and Gazetteer of the County of Lancaster*; *History of the County Palatine and Duchy of Lancaster*. He was also the author of a *History of the Wars of Napoleon*, which was continued under the title of *A History of the Reign of George III.* His *Life* (1861) has been written by his son, Edward Baines, jun., for some time editor, and still (1875) one of the proprietors, of the *Leeds Mercury*, and well known by his histories of the cotton and woollen manufactures of Great Britain.

**BAINES, MATTHEW TALBOT**, eldest son of the above, was born in 1799, and died in 1860. He was educated at Cambridge, and entered the bar. In 1837 he was made

recorder of Hull, and in 1847 was returned to Parliament for that city. His remarkable ability made itself quickly apparent, and in 1848 he became president of the Poor-Law Board. In 1852 he sat for Leeds, and was again appointed president of the Poor-Law Board, which office he held till 1855. In 1856 he was made chancellor of the Duchy of Lancaster, with a seat in the cabinet.

**BAINI, GIUSEPPE**, a learned musical critic and composer of church music, was born at Rome in 1775, and died there in 1844. He was instructed in composition by his uncle, Lorenzo Baini, and afterwards by Jannaconi. In 1814 he was appointed musical director to the choir of the pontifical chapel, in which he had for several years been one of the principal bass singers. His compositions were very favourable specimens of the severe ecclesiastical style; one in particular, a *Miserere*, was long performed alternately with the more celebrated work of Allegri in the services of the Sistine chapel during Passion week. Baini held a higher place, however, as a musical critic and historian than as a composer, and his *Life of Palestrina (Memoria storico-critica della vita e delle opere di Giovanni Pierluigi da Palestrina, 1828)* ranks as one of the best works of its class.

**BAIRAM**, a Turkish or Persian word meaning *feast*, is the name applied to the two great Mahometan festivals. The first of these, called generally, though, according to some authorities, incorrectly, the Greater Bairam, is the day following the Ramadan, or month of fasting. It lasts strictly for only one day, though the common people generally extend it to three, and is a period of great animation and enjoyment. What is called commonly the Lesser Bairam follows the first at an interval of sixty days. It is the feast of sacrifices, at which all Mahometans imitate the offerings of animals which are then being made at Mecca to commemorate Abraham's offering of Isaac. It lasts for four days, and is not of so sacred a character as the first Bairam.

**BAIRD, GENERAL SIR DAVID**, Bart., was born at Newbyth in Aberdeenshire, in December 1757. He entered the British army in 1773, and was sent to India with the 73d Highlanders in 1779. In the following year he had the misfortune to fall into the hands of Hyder Ali, in the Mysore chief's perfidious attack on a handful of British troops at Perambucum. The prisoners, it is well known, were most barbarously treated. Baird survived his captivity; and on his release, visited his native country, but returned to India in 1791 as a lieutenant-colonel. When Harris marched against Tippoo Sahib, Baird, now a major-general, served under him in that campaign; and when it was resolved to storm Seringapatam, he solicited and obtained the honour of leading the storming party to the breach. He made a daring assault, and was soon a master of the stronghold in which he had long been the prisoner. Through some misconception, Baird seems to have looked upon the temporary appointment of Colonel Wellesley to hold the captured town as permanently superseding him, and on this ground he judged himself to have been treated with injustice and disrespect. He afterwards received the thanks of the British Parliament and of the East India Company for his gallant bearing on that important day, and a pension was offered him by the Company, which he declined, apparently from the hope of receiving the order of the Bath from the Government. General Baird commanded the Indian army which was sent in 1801 to co-operate with Hutchinson in the expulsion of the French from Egypt. He landed at Kosseir, conducted his army to Keneh on the Nile, and thence to Rosetta, where he arrived just as the French were treating for the evacuation of Alexandria. On his return to India in 1802 he was employed against Scindia, but irritated at some

neglect he had experienced, he relinquished his command and returned to Europe. In 1804 he was knighted, and in the following year commanded the expedition against the Cape of Good Hope, and captured Cape Town; but here again his usual ill-luck attended him, for he was recalled before he had organised his conquest, for having sanctioned the expedition of Sir Home Popham against Buenos Ayres. He served again in 1807 in the expedition against Copenhagen, and in the following year commanded the considerable force which was sent to Spain to co-operate with Sir John Moore. In the battle of Coruña, where, after the death of Moore, he held supreme command, a grape-shot shattered his left arm, so that it had to be amputated at the shoulder-joint. He again obtained the thanks of Parliament for his gallant services, and was rewarded with the decoration of the order of the Bath, and the rank of a baronet. Sir David married Miss Campbell Preston, a Perthshire heiress, in 1810. In 1820 he was appointed commander-in-chief in Ireland; but the post does not appear to have been suitable for him, and he was removed in 1821. From that period he no more appeared in public life. He died on the 18th August 1829. (See Hook's *Life of Sir David Baird*.)

**BÄIREUTH**, or **BAIREUTH**, the capital of the circle of Upper Franconia, in Bavaria, is pleasantly situated in a valley on the left bank of the Red Main, 40 miles N.N.E. of Nuremberg. It is well built, with broad, regular, and well-paved streets, and is partially surrounded by old walls. The river is crossed here by two bridges. Most of the buildings are of comparatively modern date, the city having suffered severely from the Hussites in 1430, and from a conflagration in 1621. Among the more important are—the old castle, erected in 1454, the new castle, built in 1753, the opera-house, one of the finest in Germany, the gymnasium, founded in 1664, the riding school, and the barracks. Among the ecclesiastical buildings the *Stadtkirche*, dating from 1439, and containing the monuments of the margraves of Baireuth, is the most important; and there are also a handsome synagogue, a public library, theatre, hospital, and an orphan and a lunatic asylum. In 1841, a monument, by Schwanthaler, was erected here to Jean Paul Richter, who spent the last twenty years of his life in the city, and has left some beautiful descriptions of the neighbourhood in his *Siebentés*. His house was in Friedrichstrasse. Baireuth is a railway junction and has an active trade, chiefly in grain and horses. It manufactures woollen, linen, and cotton goods, leather, delft and other earthenware, and tobacco, and has also several breweries and distilleries. About half a league distant is the village of St George, noted for its marble works; and about two miles to the E. is the Hermitage, a fanciful building, erected in the early part of the last century, with gardens containing terraces, statues, and fountains. Baireuth has been chosen by Richard Wagner as the scene of his musical festivals, and a theatre is being erected for his special use. Population, 17,841. Baireuth was formerly the capital of a principality of the same name, which was annexed in 1791 to the kingdom of Prussia. In 1807 it was ceded by Prussia to France, which kept possession of it till 1810, when it was transferred to Bavaria.

**BAJA**, a market-town of Hungary, in the county of Bacs, on the left bank of the Danube, 90 miles S. of Pesth. It was burned down in 1807, but has since been well built. It carries on a considerable trade in grain and pigs, and its four annual markets are largely attended. The Roman Catholics, the Greek Church, and the Jews have each a place of worship in the town, which also possesses a gymnasium, and a castle belonging to the Grassalkovich family. Population, 18,110.

**BAJAZET I.**, sultan of the Turks, commenced to reign in 1389, and died in 1403. The well-known story of the iron cage, in which this monarch was said to have been carried about by his conqueror Timur, has no authority, and probably originated in a mistake as to the word for a litter, in which Bajazet was carried.

**BAJAZET II.**, son of Mahomet II., succeeded his father as sultan in 1481, and died in 1512. See **CONSTANTINOPLE** and **TURKEY**.

**BAJUS**, or **DE BAY**, **MICHAEL**, a celebrated theologian, was born at Melin in Hainaut in 1513. He distinguished himself highly during his course of study at Louvain, and was quickly promoted to a professorship in the college of that town. In 1549 he took his doctor's degree, and two years later he was appointed regius professor of divinity. On account of his eminence in theological learning he was selected by the king of Spain to go to the great council at Trent, in the proceedings of which he took a prominent part. His studies having been chiefly directed to Augustine, with whose works he was very familiar, Bajus found that his doctrines on the fundamental points of freewill, predestination, grace, and the sacraments, were in direct opposition to the scholastic theology recognised as orthodox by the powerful body of the Jesuits. Eighteen propositions, said to be gathered from the works of Bajus and his colleague Hesels, were condemned by the Sorbonne, and a more extensive collection of seventy-six were censured by Pope Pius V. in 1567. This censure, which did not press very heavily on Bajus, who was not indeed mentioned as holding the condemned doctrines, was confirmed by a bull of Gregory XIII. in 1580. Bajus, who was a man of meek and mild temper, quietly made such submission as was requisite under the circumstances, continued to hold his professorship, and even advanced to the dignity of chancellor of the university. He died in 1589, in the 77th year of his age. His principal works have been published in a collected form at Cologne, 1696, 1 vol. 4to, in 2 parts; some large treatises have not been published. The doctrines for which Bajus was censured, and the discussions arising with regard to them, are interesting in connection with the history of Jansenism, for Jansen did little more than reproduce the Augustinianism of Bajus.

**BAJZA**, **ANNOX**, a distinguished Hungarian poet and critic, was born at Szticei in 1804. His earliest contributions were made to Kisfaludy's *Aurora*, a literary paper of which he was editor from 1830 to 1837. He also wrote largely in the *Kritische Blätter*, the *Athenæum*, and the *Figyelmező*, or *Observer*. His criticisms on dramatic art were considered the best of these miscellaneous writings. In 1830 he published translations of some foreign dramas, *Ausländische Bühne*, and in 1835 a collection of his own poems. In 1837 he was made director of the newly established national theatre at Pesth. He then, for some years, devoted himself to historical writing, and published in succession the *Historical Library (Történeti Könyvtár)*, 6 vols. 1843-45; the *Modern Plutarch (Új Plutarch)*, 1845-47; and the *Universal History (Világtörténet)*, 1847. These works are to some extent translations from German authors. In 1847 Bajza edited the journal of the opposition, *Ellenőr*, at Leipzig, and in March 1848 Kossuth made him editor of his paper, *Kossuth Hírlapja*. In 1850 he was attacked with brain disease, and died in 1858.

**BÁKARGANJ**, a district of British India in the Dacca division, under the Lieutenant-Governor of Bengal, situated between 23° 14' 27" and 21° 48' N. lat., and 89° 55' 10" and 91° 4' 50" E. long. It is bounded on the N. by the districts of Dacca and Faridpur, from which it is separated by the Padmá and Mainákáttikhál; on the E. by the

Meghná and Sháhbápur rivers, and by the Bay of Bengal, which separates it from Noákhál and Tipperah; on the S. by the Bay of Bengal; and on the W. by Jessor and Faridpur districts. Area, 4935 square miles; population, 2,377,433. The general aspect of the district is that of a flat even country, dotted with clusters of bamboos and betel-nut trees, and intersected by a perfect network of dark-coloured and sluggish streams. There is not a hill or hillock in the whole district, but it derives a certain picturesque beauty from its wide expanses of cultivation, and the greenness and freshness of the vegetation. This is especially conspicuous in the rains, but at no time of the year does the district present a dried or burnt-up appearance. The villages, which are always walled round by groves of bamboos and betel-nut palms, have often a very striking appearance; and Bákarganj has many beauties of detail which strike a traveller in passing through the country. The level of the country is low, forming as it does a part of the great Gangetic delta; and the rivers, streams, and water-courses are so numerous that it is very difficult to travel except by boat at any season of the year. Every natural hollow is full of water, around the margin of which long grasses, reeds, and other aquatic plants grow in the greatest profusion, often making it difficult to say where the land ends and where the water begins. Towards the north-west the country is very marshy, and nothing is to be seen for miles but tracts of unreclaimed swamps and rice lands, with a few huts scattered here and there, and raised on mounds of earth. In the south of the district, along the sea face of the Bay of Bengal, lie the forest tracts of the Sundarbans, the habitation of tigers, leopards, and other wild beasts.

The principal rivers of the district are the Meghná, the Ariál Khán, and the Haringhátá or Baleswar, with their numerous offshoots. The Meghná represents the accumulated waters of the Brahmaputra and Ganges. It flows along the eastern boundary of the district in a southerly direction for about 100 miles, till it debouches into the Bay of Bengal. During the latter part of its course this noble river expands into a large estuary containing many islands, the principal of which is that of Dakahín Sháhbápur. The Ariál Khán, a branch of the Ganges, enters the district from the north, and flows generally in a south-easterly direction till it falls into the estuary of the Meghná. The main channel of the Ariál Khán is about 1700 yards in width in the dry season, and from 2000 to 3000 yards in the rains. It receives a number of tributaries, sends off several offshoots, and is navigable throughout the year by native cargo boats of the largest size. The Haringhátá, Baleswar, Madhumati, and Garál, are various local names for the same river in different parts of its course, and represent another great offshoot of the Ganges. It enters Bákarganj near the north-west corner of the district, whence it forms its western boundary, and runs south, but with great windings in its upper reaches, till it crosses the Sundarbans, and finally falls into the Bay of Bengal by a large and deep estuary, capable of receiving merchant ships of considerable burden. In the whole of its course through the district the river is navigable by native boats of large tonnage, and by large sea-going ships as high up as Morrellganj, in the neighbouring district of Jessor. Among its many tributaries in Bákarganj the most important is the Kachá, itself a considerable stream and navigable by large boats all the year round, which flows in a southerly direction for 20 miles, when it falls into the Baleswar. Other rivers of minor importance are the Barisál, Bishkhál, Nihálganj, Khairábad, Ghágar, Kumár, &c. All the rivers in the district are subject to tidal action from the Meghná on the north, and from the Bay of Bengal on the south, and nearly all of them are navigable at high tide by country boats of all sizes. The rise of the tide is very considerable in the estuary of the Meghná, and many of the creeks and water-courses in the island of Dakahín Sháhbápur, which are almost dry at ebb-tide, contain 18 or 19 feet of water at the flood. A very strong "bore" or tidal wave runs up the estuary of the Meghná at spring tides, and a singular sound like thunder, known as the "Barisál Gun," is often heard far out at sea about the time it is coming in. There are numerous marshes in the district, of great size and depth, and abounding in fish. The following peculiarity of some of them is quoted from Colonel Gastréll's *Geographical and Statistical Report of the District (1868)*:—"In some of the swamps, especially in those of Bákarganj, the surface growth of aquatic plants, mixed with drift weeds,

grasses, and rice stalks, increases annually, and in process of time a crust is formed capable of supporting human beings, and on which rice is cultivated. Small floating patches are thus formed, and the natives assert that in very strong blowing weather these are sometimes carried from one side of the swamp to the other, and are a cause of great dispute. A Government official, whose duties often took him to these swamps, mentioned that the first time he found himself on ground of this kind, being totally unaware of its nature, he was greatly alarmed at feeling, as he thought, the earth moving beneath him; and still more astonished when, on seeking information from the inhabitants, he was told 'it was only the tide coming in.' The owners of these floating fields make holes through them, and catch the fish which are immediately attracted by the light.

The census of 1872 disclosed a population of 2,377,433 souls in Bākarganj district, spread over 4935 square miles, inhabiting 4269 villages and 321,657 houses; persons per square mile, 482; per village, 557; per house, 7.4. The Mahometans are the largest section of the population, and number 1,540,965, or 64.8 per cent. of the total inhabitants; Hindus, 827,393, or 34.8 per cent.; Buddhist, 4049, or 2 per cent.; Christians, 4852, or 2 per cent.; and persons of unspecified religion, 174 souls. The Mussulmans of Bākarganj are among the worst of their creed, steeped in ignorance and prejudice, easily excited to violence and murder, very litigious, and grossly immoral. The Farāids or Puritan sect of Mahometans are exceedingly numerous in the district. The Buddhist population consists of Maghs or the people of Arākān, who first settled in Bākarganj about seventy years ago, and have made themselves very useful in the clearing of the Sundarbans. A gipsy-like tribe called the Babājis are rather numerous in this district. They principally live in boats, travelling from place to place, profess Muhammadanism, and gain their subsistence by wood-cutting in the Sundarbans, fishing, fortune-telling, and trading in trinkets. The Christian community of Bākarganj owes its origin to the Roman Catholic monastery at Bandal near Calcutta, and to the Protestant (Baptist) missionaries at Serampur. The principal native converts come from the Hindu low-caste Chandāls, &c., who subsist by cultivation.

Barisal, the headquarters station, situated on the west bank of the Barisal river, in 21° 41' 40" N. lat., and 90° 24' 30" E. long., is the only town containing upwards of 5000 inhabitants. In 1872 its population amounted to 7684 souls; municipal income, £1019, 18s.; municipal expenditure, £1006, 2s.; incidence of taxation, 2s. 7½d. per head. There are also three other municipal towns—(1.) Nalchiti, a large trading village; principal exports, rice and paddy; imports, salt, tobacco, oil, and sugar; (2.) Jhalakāti or Mahārājganj, a large timber market, also trading in rice, paddy, and salt; (3.) Daulat Khān, the principal village in the island of Dakahān, Shāhbāspur; exports, betel-nut. A number of small trading villages exist throughout the district, and each locality has its periodical fairs for purposes of traffic. The material condition of the people is good. Every inhabitant is a small landholder, and cultivates sufficient rice and other necessaries for the support of his family. Owing to this reason, hired labour is very scarce, and during the harvest season, when the few available labourers are sought for by the landholders, the price of labour rises to 1s. per diem. The average cost of living to a labouring man is about 6s. per month. Except in the larger villages, the dwellings of the people are very isolated. The inhabitants seldom congregate together into hamlets, but each man builds his homestead on the highest spot on his own land without any reference to his neighbours. Rice is the great crop of the district, and three harvests are obtained annually—the *amas*, or winter rice; *das*, or autumn crop; and *boro*, or spring rice. The former yields the finest grain, and is the staple crop of the district. It is sown at the setting in of the rains in April or May, transplanted from the beginning of June to the middle of August, and reaped in November or December. About 100 varieties of the *amas* rice are cultivated in the district. The *das* crop is sown in the early part of the hot weather, and reaped in August. Upwards of 20 varieties of this rice are produced. The *boro* or spring rice is of a coarse description, largely used by the poorer classes, and is cultivated to a considerable extent in the alluvial river accre-

tions, and on other low-lying grounds. It is sown broadcast in December, and reaped in April or May. Bākarganj exports its rice chiefly to Calcutta. The average yield of rice land here is from 17½ to 22 cwt. per acre. Other crops—*khesari* (*Lathyrus sativus*), *masuri* (*Cicer lens*) *varishā* or mustard, rape-seed, linseed, jute, sugar-cane, betel-nut, &c. Manufactures—pottery, coarse cloth, oil, fine mats, and molasses. The district has only five small roads, but its rivers afford ample means of communication.

Like all other districts of Bengal, Bākarganj has steadily increased in prosperity since its administration passed into the hands of English officers, and especially of late years, since the country has been directly under the Crown. From the time of the acquisition of Bengal by the British in 1765 up to the end of 1817, Bākarganj formed a part of the Dacca district. It was then formed into a separate collectorship, with the object of encouraging enterprising persons to cultivate its immense tracts of waste lands. In 1818 the net revenue of the district amounted to £96,438, and the net civil expenditure to £13,647. Two years later (1820) the net district revenue had slightly decreased to £95,709, while the net expenditure on civil administration had increased to £16,659. During the next forty years both revenue and expenditure rapidly increased, and in 1860–61 the net revenue of the district amounted to £150,305, and the net civil expenditure to £32,584. In 1870–71 the total net revenue was £203,445, and net civil expenditure, £44,902. The land revenue of Bākarganj is settled in perpetuity with the *samādars*. In 1872 the district contained 4729 estates, held by 5960 proprietors, who were assessed at a total revenue of £143,156. In 1871 the machinery for protecting the district consisted of 583 men of the regular police of all ranks, maintained at a total cost of £11,186. Attached to the regular police is a river patrol consisting of five boats, and manned by a crew of 35 men. The village watch or rural police consisted in 1871 of 5135 men, maintained at a cost of £18,486, paid by the landholders and villagers, each village watchman having besides a small plot of ground rent free. A municipal police of 53 men was also maintained in the towns and large villages, at a total cost of £403, 14s., defrayed out of municipal receipts. Education is in a very backward state in Bākarganj, owing to the inhabitants being almost wholly composed of petty husbandmen, the majority of whom are Mahometans of the most bigoted tenets. In 1856–57 the district contained 5 schools, attended by 482 pupils, and maintained at a total cost of £595, 13s. In 1871–72 there were 78 Government and aided schools, attended by 3713 pupils, and maintained at a total cost of £3767, 12s., the total cost to the state being £1232, 10s. This is exclusive of private schools uninspected by the education department. The census report of 1872 returned the total number of schools (Government and private) at 512, attended by a total of 7299 pupils. Barisal town contains a Government school, which is the largest in Eastern Bengal, and financially the most successful; the cost to Government for its 355 pupils in 1872 being only £31, 12s. Bākarganj district is divided into 5 magisterial sub-divisions, viz., Barisal, Dakahān Shāhbāspur, Mādāripur, Pirozpur, and Patākhālī, comprising 18 police circles or *thānds*, and 54 fiscal divisions or *pargands*. The climate of Bākarganj is one of the healthiest in Eastern Bengal, owing to the strong south-west monsoon, which comes up directly from the Bay of Bengal, and keeps the atmosphere cool; but the heavy rain-fall and consequent humidity of the atmosphere, combined with the use of bad water, are fruitful sources of disease. The average annual temperature varies from 78° to 85°. The thermometer ranges from 62° to 98°. The endemic diseases of Bākarganj

ganj are fevers of the intermittent, remittent, and continued types, attributable to the extreme dampness and malarious nature of the district. Cholera is always present. The number of cases increasing in the hot season and the beginning of the cold weather. Smallpox occasionally makes its appearance in an epidemic form,—frequently caused by inoculation, which is carried on to a great extent in Bakarganj by the native medical practitioners.

BAKER, HENRY, a distinguished naturalist, was born in Fleet Street, London, in 1698. At the age of fifteen he was apprenticed to a bookseller, with whom he remained for seven years. He then became clerk to Mr Forster, attorney, whose deaf and dumb daughter he instructed carefully, and with such success that for a time he devoted himself to the training of persons similarly afflicted. During this period of his life he published several poems, and married Sophia, youngest daughter of the famous Daniel Defoe, who bore him two sons, both of whom he survived. In 1740 he was elected fellow of the Society of Antiquaries and of the Royal Society. He contributed many memoirs to the *Transactions* of the latter society, and in 1744 received the Copley gold medal for microscopical experiments on the crystallisation and configuration of saline particles. Mr Baker died at his apartments in the Strand on the 25th of November 1774. Besides his numerous memoirs in the *Philosophical Transactions*, he published two valuable treatises on the microscope: *The Microscope made Easy*, London, 1743, and *Employment for the Microscope*, 1753. Another well-known work is his philosophical poem, *The Universe*, which has passed through several editions. Mr Baker's memory is perpetuated by the Bakerian Lecture of the Royal Society, for the foundation of which he left by will the sum of £100.

BAKER, SIR RICHARD, author of the *Chronicle of the Kings of England*, was born at Sissinghurst, in Kent, about the year 1568. He was educated at Oxford, took the degree of Master of Arts, and in 1603 received the honour of knighthood. In 1620 he was made high sheriff of Oxfordshire; but having engaged to pay comodebts of his wife's family, he was reduced to poverty, and obliged to betake himself for shelter to the Fleet prison, where he died, February 18, 1645. During his confinement he composed numerous works, historical, poetical, and miscellaneous. Amongst these are *Meditations and Disquisitions on the Lord's Prayer*; *Meditations, &c., on several of the Psalms of David*; *Meditations and Prayers upon the Seven Days of the Week*; *Cato Variegatus, or Cato's Moral Disticks*; *Theatrum Triumphans, or Theatrum Redivivum*, being a reply to Prynne's *Histriomastix*, &c. His principal work, the *Chronicle of the Kings of England*, inexact and uncritical, but written in a pleasant and readable style, quickly acquired a high reputation. It was continued to 1658 by Edward Phillips, Milton's nephew, and has passed through many editions.

BAKER, THOMAS, a learned antiquary, descended from an ancient family distinguished by its loyalty, was born at Crook in 1636. He was educated at the free school at Durham, and proceeded thence, in 1674, to St John's College, Cambridge, where he afterwards obtained a fellowship. Lord Crew, bishop of Durham, collated him to the rectory of Long-Newton in his diocese, in 1687, and further intended to give him that of Sedgfield, with a golden prebend, had not Baker incurred his displeasure for refusing to read James II.'s Declaration of Indulgence. The bishop who disgraced him for this refusal, and who was afterwards specially excepted from William's Act of Indemnity, took the oaths to that king, and kept his bishopric till his death. Baker, on the other hand, though he had opposed James, refused to take the oaths to

William; he resigned Long-Newton on the 1st of August 1690, and retired to St John's, in which he was protected till the 20th of January 1716-17, when he and one-and-twenty others were deprived of their fellowships. After the passing of the Registering Act in 1723, he could not be prevailed on to comply with its requirements by registering his annuity of £40, although that annuity, left him by his father, with £20 per annum from his elder brother's collieries, was now his whole subsistence. He retained a lively sense of the injuries he had suffered; and inscribed himself in all his own books, as well as in those which he gave to the college library, *socius ejectus*, and in some *vector ejectus*. He continued to reside in the college as commoner-master till his death on the 2d of July 1740. The whole of his valuable books and manuscripts he bequeathed to the university. The only works he published were, *Reflections on Learning, showing the Insufficiency thereof in its several particulars, in order to evince the usefulness and necessity of Revelation*, Lond. 1709-10, and the preface to Bishop Fisher's *Funeral Sermon for Margu et, Countess of Richmond and Derby*, 1708,—both without his name. His valuable manuscript collections relative to the history and antiquities of the university of Cambridge, amounting to thirty-nine volumes in folio and three in quarto, are divided between the British Museum and the public library at Cambridge,—the former possessing twenty-three volumes, the latter sixteen in folio and three in quarto. The life of Baker has been written by Robert Masters, 8vo, 1784, and by Horace Walpole, in the quarto edition of his works.

BAKEWELL, a market-town in Derbyshire, on the River Wye, 152 miles from London. Its fine old church contains monuments of the families of Vernon and Manners. The inhabitants are supported by the working of the coal, lead, and zinc mines, and the stone and marble quarries in the neighbourhood. There is also a large cotton manufactory in the town established by Arkwright. Bakewell is remarkable for a chalybeate spring frequented by invalids. It has a free school of ancient date, a literary and scientific institution, and a museum. About four miles distant is Chatsworth House, the seat of the duke of Devonshire. Population in 1871, 2283.

BAKHCHISARAI (Turkish, *the Garden Palace*), a town of Russia in the government of Taurus, situated in a narrow gorge on the banks of a small stream called the Chiryuk-Su, about 10 miles S.E.W. of Simpheropol. Of unknown origin, it became towards the close of the 15th century the residence of the Tatar khans; and its chief objects of interest are the remains of its splendour under the Tatar dynasty. The principal building, the palace, or *Khan-Serai*, was originally erected in 1519 by Abdul-Sahal-Gerai, and was restored at Potemkin's command by the architect Elson for the reception of Catherine. Not far off is a cemetery, which contains the tombs of many of the khans. There are, besides three or four churches and a synagogue, no fewer than thirty-five mosques, of which the most important was founded in the early part of the 18th century. The population still consists for the most part of Tatars, Catherine II. in 1783 having granted them the exclusive right of habitation in the city. The remainder consists of Russians, Greeks, Armenians, and Jews. Bakhchisarai is a place of considerable industry, manufacturing red and yellow morocco, sheepskin cloaks, agricultural implements, sabres, and other cutlery, and forming an important depôt for the corn, flax, fruits, tobacco, and other produce of the whole surrounding district. In the neighbourhood is Chufut-Kali (or Jews' city), the chief seat of the Karaitic Jews of the Crimea, situated on lofty and, except on one side, inaccessible cliffs. Population, 10,528.

**BAKHMUT**, a town of Russia in the government of Ekaterinoslav, near the river from which it derives its name. It owed its origin in the latter half of the 17th century to the discovery of salt-springs, which ceased, however, to be utilised in 1782. Its present importance is chiefly due to the extensive coal-deposits in the vicinity. Population, 16,791

**BAKING**. The art of baking consists in heating anything in an oven or fire so as to harden it, and in this sense the term is used when applied to the manufacture of bread, porcelain, pottery, and bricks. It is also applied to certain modes of dressing or cooking animal food; thus we speak of baked meats, pies, &c. In the present article the baking of flour or meal for use as human food will alone be treated of.

The origin of baking, as of most arts of primary importance, precedes the period of history, and is involved in the obscurity of the early ages of the human race. Excavations conducted on the site of some of the numerous lake dwellings of Switzerland have resulted in the discovery of abundant evidence that the art of making bread was practised by our prehistoric ancestors as early as the Stone Period. Not only have stones for grinding meal and baking bread been discovered, but bread itself in large quantities has been disinterred, preserved by being carbonised in the fires which frequently destroyed the pile-dwellings of the primitive inhabitants of the world. At Robenhausen, Meisskomer discovered 8 lb of bread, a weight which would correspond with about 40 lb of newly-baked bread. At Wangen there has been discovered "actual baked bread or cake made of the crushed corn, precisely similar to that found about the same time by Mr Meisskomer at Robenhausen. Of course, it has been burned or charred, and thus these interesting specimens have been preserved to the present day. The form of these cakes is somewhat round, and about an inch to an inch and a half in diameter. The dough did not consist of meal, but of grains of corn more or less crushed. In some specimens the halves of grains of barley are plainly discernible. The under side of these cakes is sometimes flat, sometimes concave, and there appears no doubt that the mass of dough was baked by being laid on hot stones and covered over with glowing ashes."—(Keller's *Lake Dwellings*, Lee's Translation, p. 68.)

The very early mention of bread in written history further bears out the great antiquity of the art of baking. Bread is first specifically mentioned in Genesis xviii. 5, when Abraham, wishing to entertain the three angels on the plains of Mamre, offered to "fetch a morsel of bread;" and the operation of baking is immediately thereafter alluded to in the instructions to Sarah to "make ready quickly three measures of fine meal, knead it, and make cakes upon the hearth." At the same time, when, in the city of Sodom, Lot entertained two angels, "he made them a feast, and did bake unleavened bread, and they did eat" (Genesis xix. 3). It may be inferred from the mention of unleavened bread that, in those patriarchal times, the two great classes of bread were known and used. At a period little later the art of baking was carried to high perfection in Egypt, which then took the lead in the arts of civilised life. The Egyptians baked cakes and loaves of many varieties and shapes, in which they employed several kinds of flour, and they flavoured their bread with various aromatic ingredients. The chief baker of Pharaoh, who was in prison along with Joseph, doubtless pursued his craft in its essential features in the same way as bakers do at the present day.

From ancient Egypt excellence in the art of baking travelled with the march of civilisation into Greece, and the allusions to bread in the works of classic authors are very

numerous. In *The Deipnosophists* of Athenæus mention is made of no less than sixty-two varieties of bread as known among the ancient Greeks, and minute descriptions of many of them are given. We learn from Pliny (*Nat. Hist.*, xviii. 28) that professional bakers were first introduced into Rome at the close of the war with Persæus, king of Macedon. By the practical Romans the baking trade was formed into a kind of incorporation or guild, with special privileges and immunities attached to the calling. Public bakeries were distributed throughout the city, to which slaves were assigned for performing the heavier and more disagreeable tasks connected with the occupation. Grain was delivered into public granaries by enrolled *Saccarîi*, and it was distributed to the bakers by a corporation called the *Catabolenses*. No separate mills for grinding corn then existed, the grain being pounded and sifted in the bakeries, and hence the Roman bakers were known as *Pistoræ*. A special magistrate was appointed to take cognisance of every matter connected with the management of public bakeries.

The calling of the baker during the Middle Ages was considered to be one so closely affecting the interests of the public that it was put under strict regulation and supervision, and these special restrictions continued to affect the trade down to very recent times. In England, an Act of Parliament was passed in 1266 for regulating the price of bread by a public assize, and that system continued in operation till 1822 in the case of the city of London, and till 1836 for the rest of the country. The price of bread was determined by adding a certain sum to the price of every quarter of flour, in name of the baker's expenses and profit; and for the sum so arrived at tradesmen were required to bake and sell eighty quarter loaves, or a like proportion of other sizes, which it was reckoned each quarter of flour ought to yield. The following table exhibits the assize price of bread in London in 1814:—

Price of Flour in Shillings.	Price of Quarter Loaf.		Price of 8-lb Loaf.		Price of 4-lb Loaf.		Price of 3-lb Loaf.		Price of 1-lb Loaf.	
	s	d	s	d	s	d	s	d	s	d
30	0	6½	1	0	0	6	0	3	0	1½
35	0	7½	1	1½	0	6½	0	3½	0	1½
40	0	8	1	2½	0	7½	0	3½	0	1½
45	0	8½	1	4	0	8	0	4	0	2
50	0	9½	1	5½	0	8½	0	4½	0	2½
60	0	11	1	8½	0	10½	0	5	0	2½
70	1	0½	1	11	0	11½	0	5½	0	3
80	1	2	2	1½	1	1	0	6½	0	3½
90	1	3½	2	4½	1	2½	0	7½	0	3½
100	1	5	2	7½	1	3½	0	7½	0	4

The art of making bread made its way northwards very slowly; and even at present, in the northern countries of Europe and Asia, loaves of bread are seldom used except by the higher classes of inhabitants. In Sweden, for example, rolls are frequently seen in the towns, but loaves rarely. Towards the end of 1812 the captain of an English packet ordered a Gothenburg baker to bake for him a quantity of bread, to the value of £1 sterling. The baker was confounded at so large an order, and refused to comply till the captain gave him security that he would carry off and pay for the loaves, declaring that he could never dispose of so great a quantity of bread in Gothenburg if it were left upon his hands. In the country part of Sweden no bread is made but rye-cakes, nearly as hard as flint, which are only baked twice a year. About a century ago loaf-bread was almost as rare in the rural districts of Scotland, *barley bannocks* and *oaten cakes* then constituting the universal substitutes, among all ranks. In many parts of England it is the custom for private families to bake their own bread. This is particularly the case in

Kent, and in some parts of Lancashire. In the year 1804 the town of Manchester, with a population of 90,000 persons, did not contain a single public baker. Bakers in Great Britain are now placed under the provisions of "The Bakehouses' Regulation Act, 1863" (26 and 27 Vict. cap. 40), a statute passed after a searching inquiry into the condition of bakehouses in London and of the persons employed in them. By this Act no young person under the age of 18 is permitted to work in a bakehouse between the hours of 9 P.M. and 5 A.M., and special enactments provide for securing the cleanliness and ventilation of bakehouses, and for the regulation of sleeping apartments connected with them.

As compared with wheat-flour all other materials used for making bread are of comparative insignificance. Oat cakes still form a staple article of food in many rural districts of Scotland, and are occasionally used in other countries. They are made by mixing up oatmeal, warm water, and salt, sometimes with the addition of butter or fat, into a very stiff paste, and kneading this out into a thin cake, which is first fired on a hot plate or "girdle," and finished in front of an open fire. Scones of barley-flour, sweet and tough, were formerly largely used in Scotland, but have now given place to a similar preparation of wheaten flour. Rye bread, both fermented and unfermented, is largely consumed by the inhabitants of the northern parts of Europe in the poor and backward districts. Cakes of maize meal, baked like oat cakes, are consumed in some parts of the United States. The meal of various species of millet is used in Southern Europe to form bread and in India and China, durra (*Sorghum vulgare*) and other cereal grains are baked for food. Of non-cereal flours the principal used for bread-making is buckwheat, *Fagopyrum esculentum*, extensively employed in Russia and Holland. The flour of pease, beans, and other leguminous seeds, are also baked into cakes, and cassava cakes are made from the meal of the tapioca plant, *Jatropha Manihot*, in South America. Excepting rye, none of these substances is used for making vesiculated or fermented bread.

The grain of wheat consists of an outer husk or covering, an embryo or germ, and a central mass of farinaceous material. The outer husk is composed of several distinct layers of ligneous tissue, closely adhering to the seed, and very hard in texture. In grinding, this is detached in scales, and constitutes the chief proportion of the bran. The inner portion of the envelope is softer, and contains an active nitrogenous principle, termed cerealine, and is besides rich in fat and salts. This portion goes with the pollard or parings in the dressing of wheat flour. Towards the centre of the grain the substance becomes whiter in colour and more friable in texture, so that, in grinding, the finest flour in consistence is always the whitest in appearance. By agriculturists several hundred varieties of wheat and a number of distinct species are recognised; but in commerce the grain is distinguished as white and red, or as hard and soft wheats. There is a considerable range of difference in the proportions of their proximate constituents, hard wheats as a rule being much more nitrogenous than the soft varieties; and similarly, wheats grown in hot climates are also usually richest in nitrogen. The following analyses of two typical varieties of wheat are taken from Payen's tables, water being neglected:—

	Hard Wheat Tegaurog.	Soft Wheat Tonsella.
Nitrogenous matter.....	20.00	12.65
Starch.....	63.80	74.51
Dextrin.....	8.00	6.05
Cellulose.....	3.10	2.80
Fatty matter.....	2.25	7.87
Mineral matter.....	2.85	2.12

When wheat is ground it is sifted or dressed into a series

of mill products, ranging from fine flour to bran, according to the size of the ground particles. The divisions vary in different mills and localities; but the accompanying table—the result of an elaborate series of experiments by Messrs Lawes and Gilbert—may be regarded as a standard of the relative proportions of mill products:—

Mean Yield of Flour, Bran, &c., in 100 parts Meal

	Wheat of 1846 7 Cases.	Wheat of 1847. 16 Cases.	Wheat of 1848. 2 Cases.	Mean of The 26 Cases.
1. Wire 1. ....	44.0	35.7	47.4	41.1
2. Wire 2. ....	17.0	16.4	23.9	18.6
3. Wire 3. ....	8.7	13.3	2.0	9.2
Amounts of 1, 2, and 3 together.....	69.3	70.2	73.3	70.2
4. Tails.....	4.9	5.8	2.1	5.3
5. Fine Sharps or Middlings	10.2	8.7	4.5	8.8
6. Coarse Sharps.....	3.5	3.3	3.6	3.4
7. Fine Pollard.....	3.9	1.8	2.6	2.4
8. Coarse Pollard.....	4.4	7.2	7.9	6.5
9. Long Bran.....	3.5	2.5	5.9	3.0

The tails and fine sharps are generally passed through the mill a second time, bringing up the yield of flour to about 80 per cent. of the entire grain. As an example of mill products in practice, the following table is copied from the actual mill receipts of a Scotch miller. The quantity dealt with represents 16 quarters of wheat, weighing 63½ lb per bushel in all 578 st. 11 lb. The yield was—

	st.	lb.
Fine Flour.....	41	0
Odd and Second Flour.....	23	13
Parings (Sharps and Pollards).....	36	12
Bran and Shellings.....	99	0
Waste.....	11	0

The composition of flour and bran given in the understated table is the mean result of a series of fourteen analyses by Peligot:—

	Flour	Bran.
Water.....	14.0	10.30
Fatty matters.....	1.2	2.32
Nitrogenous substances insoluble in water (gluten)	12.8	10.84
"    soluble    "    (albumen)	1.8	1.64
Non-nitrogenous soluble substances—dextrin, sugar.	7.2	5.80
Starch.....	59.7	52.62
Cellulose.....	1.7	43.98
Salts.....	1.6	2.52

It is a disputed point whether dextrin or sugar exists in flour of the best quality; but the action of heat and moisture in the baking process quickly transforms a portion of the starch into the soluble condition. In flour of inferior quality a large percentage of dextrin is usually found—a circumstance very detrimental to its bread-making qualities. A table of the percentage of gluten, obtained by Messrs Lawes and Gilbert from a large number of flours, shows a variation from 8.9 to 14.9 per cent. This gluten itself (the insoluble nitrogenous substance in flour) is a compound body, composed of three or four distinct substances; but its physical conditions of elasticity, tenacity, and colour are of much greater importance to the baker than either its chemical constitution or its amount.

The varieties of wheaten bread are divisible into two great classes—*Unvesiculated* and *Vesiculated Bread*. Under the first head are included such products of the art as are fired or baked without first being raised or rendered spongy by the development of carbonic acid gas within the mass, either by fermentation or otherwise. Vesiculated bread is produced when carbonic acid is either developed in or introduced into the dough, so as to permeate the mass with an infinite number of minute cavities, which render the product light and spongiform.

**UNLEVIGATED BREAD.**—The simplest form of bread, and the rudest baking, are seen in the Australian "Damper," a cake made from dough composed of flour, salt, and water, baked in the dying embers of a wood fire. The dough is laid on a flat stone, covered with a tin plate, and the hot ashes heaped around and over it, care being taken not to expose it to a heat of more than 212° Fahr. Pass-over cakes, scones, and "bannocks" are prepared from a similar dough, and fired on hot plates or in ovens, and form an agreeable and nutritious food. When such dough is exposed to a high heat, so that the resulting cake is hard, dry, and resonant, biscuits (*bis cuit*, twice baked) are formed.

**Biscuit Manufacture.**—Biscuit making is a branch of trade distinct from ordinary baking, conducted under different conditions, and requiring machinery and processes peculiar to itself. Biscuits are made by a rapid and continuous process; they can be preserved a long time, and in proportion to their price they occupy little space, so that it is practicable to sell them in markets remote from the place of manufacture. The manufacture of biscuits is now conducted on a very large scale, ingenious and complicated machinery is employed in the various processes, and a large export trade in biscuits has grown up. The firm of Messrs Carr & Co., of Carlisle, was the first to originate the manufacture, and that firm still possesses one of the largest and best-appointed establishments. To the partners of this firm we are indebted for much information as to the processes employed in this modern industry.

The general arrangements of a ship-biscuit factory are shown in the sectional view, fig. 1. The flour stored on the

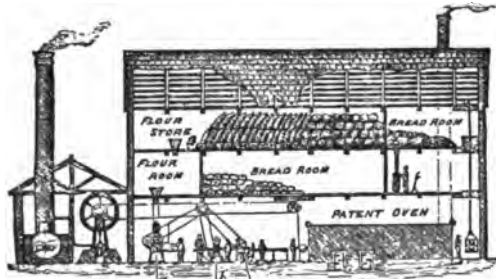

FIG. 1.—Sectional view of Ship-Biscuit Factory.

upper floor is passed down through a shoot to the flour-room, where it is sifted to free it from knots or lumps. In the making of plain water or ship biscuits, the flour is shot directly down into the mixer *a*, on the ground floor, in quantities usually of one bag at a time, to which the requisite quantity of water, regulated by a gauge-glass, is added. The mixer is a cylindrical vessel of cast-iron, in which a series of knives or arms is kept revolving on a central axis. The revolution of these knives is sufficient to incorporate the flour and water thoroughly into a very stiff dough in about seven minutes. From the mixer the dough is delivered on a table in large amorphous masses, and it is next carried forward to the brake machine *b*. The brake consists of two heavy iron rollers, having generally a reciprocating motion, between which the dough is passed backwards and forwards several times till it is rolled out into a plate or sheet of uniform thickness and consistency. The sheet of prepared dough is next carried forward to the cutting and panning machine *c*, a highly complex and ingenious apparatus, the principle of which is shown in fig. 2. In this machine the dough is first passed between a pair of gauge rollers *a*, graduated to secure a sheet of any desired uniform thickness, from which it is received on an endless sheet of felt *b*. On this web the sheet of

dough is carried forward by intermittent motion to a punching apparatus *c*, in which moulds or cutting edges of the

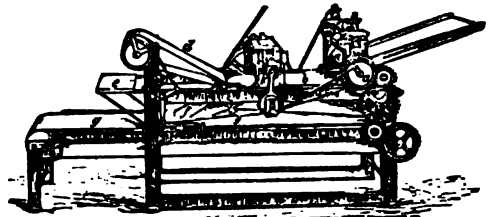

FIG. 2.—Cutting and Panning Machine.

size and form of biscuit desired are arranged. Here the biscuits are cut out, the scrap being caught on a web *d*, and carried upward till it falls over in a box or trough on the table *e*, from which it is returned to the brake machine. The biscuits are carried down the web *f*, and fall into tin trays, which are fed in at *g* by a boy, and move forward at the same rate the biscuit web travels, so that they are ready for being immediately placed on the travelling stage of the patent oven. The processes are so arranged that the oven carries forward the biscuits as quickly as they are delivered by the cutting machine, and in some cases the ovens are fed direct from the cutting and panning apparatus by automatic machinery. The patent travelling ovens are constructed from 30 to 44 feet long, and fitted with endless webs either of plates or chains. The chain webs are used for baking small and fancy biscuits, such as are placed in trays, and the plates are used for large and plain water biscuits, which are placed by hand on the travelling plates. The rates at which biscuits of different sizes and degrees of richness must traverse the whole length of the oven varies from about five to forty minutes, and the temperature of the oven has also to be modified to suit the various qualities. Both the heat and rate of motion are under easy and adequate control in the patent ovens.

There is an endless variety in the form and composition of plain and fancy biscuits. In the trade list of Messrs Vicars, of Liverpool, the chief manufacturers of biscuit machinery, the names of 123 varieties of cutters are mentioned. In the making of fancy biscuits, milk, eggs, sugar, butter or lard, and flavouring essences are extensively used, and in these cases the proportions of the various ingredients are roughly mingled before being sent down the shoot into the mixer. The richest class of biscuits, the dough for which is necessarily soft, are cut out by hand labour, and fired on trays in common ovens. The dough for rout biscuits is placed in a strong metal box or chamber in which a piston is tightly fitted. The piston is moved forward by a screw, and it pushes the dough through a series of holes or dies. The dough is received on a sliding board, and is cut into proper lengths by a knife. Cracknels are made without either milk or water being used to mix the dough, eggs alone being employed for this purpose. Certain proportions of butter, sugar, and sesquicarbonate of ammonia are added to the mixture of flour and eggs, and the dough is baked in the usual way. The cracknels, when cut out, are thrown into a boiler of boiling water, and in about two minutes they float to the top. They are then fished out and thrown into cold water, and then drained on cloths, panned, and fired in an ordinary oven at a high heat. In the firing, the ammoniac carbonate, being very volatile, is driven off, and the cracknel thus assumes its spongy structure. Many other varieties of biscuits are rendered light and spongiform by the use of the sesquicarbonate of ammonia, or of carbonate of soda, in conjunction with sour milk. In the firing of biscuits, not only the moisture of the dough is driven off, but a certain pro-



portion of the water held by the flour in its apparently dry state, so that from 10 lb of flour only about 9 lb of water biscuits are obtained. The composition of plain biscuit is given by Dr Parkes as follows:—

Water.....	8 to 12	Sugar.....	1-9
Nitrogenous substances	15	Fat.....	1-3
Dextrin.....	3-8	Starch.....	72 to 75

**VEVICULATED BREAD.**—Under this head is included such bread as is rendered spongiform in structure by the action of carbonic acid within the dough, and which is not baked hard and dry as in the case of biscuits. It includes ordinary loaf bread, pan loaves, French or Paris loaves, cottage loaves, bricks, rolls, buns, and many varieties of fancy bread distinguished by local names and minor differences of form and composition. Vesciculated bread is made in three different ways:—

1st, By the development of carbonic acid within the dough through fermentation of the flour. This is the ordinary and principal method of bread-making.

2d, By mixing the dough with water previously aerated with carbonic acid. The aerated bread made under the patent of the late Dr Daughish is thus manufactured.

3d, By the disengagement of carbonic acid from chemical agents introduced into the dough. Dodson's patent unfermented bread comes under this head, and the "baking powders" and "yeast powders" extensively sold consist generally of carbonate of soda or ammonia and citric or tartaric acid, which evolve carbonic acid in presence of water.

**Fermented Bread.**—The manufacture of fermented or leavened bread is, as has already been hinted, of very great antiquity, and it is still by the fermentation process that bread is chiefly made. In ancient times leaven was employed to induce fermentation in dough ("a little leaven leaveneth the whole lump," Gal. v. 9), and to this day Parisian bakers, who excel all others in the quality of the bread they produce, chiefly use the same ferment. Leaven is simply a portion of dough, put aside from a previous baking, in which the fermentative action has reached an advanced stage of activity. Yeast, however, has been used as a ferment from an early period, and it appears that it was first so employed in France. Pliny says (*Nat. Hist.*, xviii. 12), "Gallie et Hispanie frumento in potum resoluto, spuma ita concreta pro fermento utuntur; qua de causa levior illis quam cæteris panis est." The use of yeast appears to have died out in France, but was revived again towards the end of the 17th century, when its reintroduction was violently opposed by the Faculty of medicine of Paris. Yeast is now used by Parisian bakers for fancy bread and pastry only.

The baking of fermented bread involves three distinct operations, which are technically denominated "setting the sponge," making the dough or kneading, and baking or firing. It will be convenient first to describe these processes as they are conducted in a London bakehouse. The first duty of the baker is to mix a ferment, which consists of a mixture of potatoes, yeast, and flour. The potatoes, in the proportion of 6 lb to a sack of flour, are boiled and mashed in a tub, and water is stirred in till the mixture is reduced to a temperature of from 70° to 90° Fahr. About 2½ pints of yeast and 12 lb of flour scalded in boiling water are then added, and the whole forming a thin uniform paste is set aside for several hours, during which it undergoes an active fermentation. Setting the sponge consists in mixing the ferment in a large crough with flour and water sufficient to make the whole into a rather stiff paste. The flour used at this stage, when "full sponge" is made, should be about one-half the entire quantity intended to be used in the "batch," and the ingredients have to be thoroughly incorporated by the workman

stirring them laboriously together with his arms. The operation occupies from twenty minutes to half an hour, and when ready the sponge is covered over and allowed to rest for several hours according to the temperature at which it is maintained. Generally in from four to five hours the sponge "rises;" fermentation has been going on, and carbonic acid steadily accumulating within the tenuous mass till it has assumed a puffed out appearance. By degrees the sponge gives off the gas in puffs, and the mass begins to collapse, till what was a swollen convex surface assumes a somewhat concave form, the centre being depressed while the sides adhere to the edges of the trough. The workman judges by the amount of collapse the time the sponge is ready to be taken in hand for kneading or making the dough. This process is thus described by an eye-witness:—"The batch consisted of a sack and a half of flour, nearly one-half of which had been used in making the sponge. Two men commenced breaking the sponge at 1.4 P.M. Having poured the water into it, they plunged their arms in and stirred it about until it became of the consistency of thin batter. At 1.10 they began to mix the dry flour with it, immediately upon doing which they were enveloped in a cloud of flour dust, their heads being bent down to within a few inches of the mass they were handling. Flour and pieces of dough were splashed over the trough upon the floor. At 1.12 a third man was added. Their hair, caps, and face powdered thickly with the dust, a thick cloud of which was thrown up with every movement, especially when large masses of dough, as it became a little solid, were taken up in their arms and thrown upon the rest, fresh flour being first strewn between. At 1.15 one of the men became very red and heated. The other two were very pale, and did not show any perspiration. At 1.16 the cutting off of large masses began, as much as two men could lift to place over the adjoining mass. At 1.23 the men began to pound the mass with their fists. At 1.26 one of the pale men, who was also very thin, began to look red and hot. At 1.29, after smoothing the mass down, they began again to pound it with their fists. At 1.30 it was again smoothed over, the sides of the trough scraped, and a little dry flour thrown over it. It was then considered finished." After this laborious process the finished dough is covered over for some time, varying from half an hour to two hours according to the temperature, during which fermentation again begins, and the mass is "proofed." It is then "scaled off," i.e., weighed on scales in pieces of 4 lb 4 oz, if 4-lb loaves are to be made, or half that amount for 2-lb loaves; and as rapidly as weighed it is "moulded" into the form of the loaf, when it is ready to put into the oven. Flour of good quality will take up about 17 gallons of water in course of the foregoing operations, and before putting into the oven the ingredients of a 4-lb loaf will be—

	lb	oz.
Flour.....	3	2
Water.....	1	1½
Yeast.....	0	0½
Potatoes.....	0	1½
Salt.....	0	0½

A loaf ready for going into the oven has about half the bulk it attains during the process of firing. Batches of cottage and household loaves are packed close side by side on the sole of the oven, the sides of each loaf being rubbed with butter to prevent them from adhering to each other, and they are consequently crusted on the top and bottom only. Pan loaves are baked each in separate tinned pans of the form of the loaf, and Parisian loaves are baked end to end in long tinned pans. The firing of bread in the oven occupies from 1 to 1½ hours, the temperature at the

<sup>1</sup> Tremenheere's Report on Journeymen Bakers.

beginning of the process being from 550° to 600° Fahr. The baker can ascertain if the oven is at a proper temperature by throwing a little flour on the sole of the oven, which ought to turn to a light brown colour. Ovens in London are usually built of brick, with a sole only 2½ inches thick; in Scotland stone is used, the sole being from 10 to 12 inches thick, and the oven consequently retains heat much more effectually.

In Scotland the system of using ferments is not generally practised as in London, some of the varieties of yeast or barm being mixed directly with the flour. In some localities the system of setting "quarter sponge" is adopted, in which the sponge originally prepared contains only one-fourth of the flour to be used. To this, after an interval of about twelve hours, more flour and water are added, which brings it up to half sponge, and about two hours thereafter the mass is ready for making the dough. In Paris, where bread-making is carried to the highest perfection, leaven, as has already been mentioned, is the fermenting agent employed. This consists of a portion of dough laid aside from a previous baking in a uniform temperature for seven or eight hours, during which it swells and acquires an alcoholic odour. This, termed "the chief leaven," is taken and worked up with flour and water to a firm paste double its original mass, when it becomes "the first leaven." After an interval of six hours the amount is again doubled, forming the second leaven. The "complete leaven" is formed by doubling the size of the second leaven, and the proportion the complete leaven bears to the finished dough is about one-third in summer and one-half in winter.

Sound flour yields from 90 to 91 4-lb loaves per bag of 280 lb, some "strong" flours giving even a greater quantity of bread. A table of experiments, conducted by Messrs Lawes and Gilbert, gives a mean result of 135·2 of bread from 100 of flour; and in the observations of a large number of English and French authorities, quoted by them, the ratio of bread to 100 of flour varied from 127 to 150. The following table gives the mean of 25 analyses of the bread of London bakers by Dr Odling:—

Water .....	43·48
Organic matter .....	55·26
Mineral matter or ash .....	1·30
Percentage of ash in dry bread .....	2·30
"    nitrogen in new bread .....	1·26
"    "    in dry bread .....	2·22

The bakers' standard of excellence of flour, apart from the question of colour, is the weight of bread it will produce of a proper dryness and texture. The "strength" of flour in this respect appears to depend much more on its condition than on the absolute percentage of its constituents.

*Panary Fermentation.*—It would be altogether out of place in this paper to refer to the conflicting theories as to the cause of fermentation in organic substances. The so-called panary fermentation in bread-making is a true alcoholic fermentation, and whether induced by yeast or leaven the result is precisely the same. The gluten of the flour is the fermenting agent, and it is stirred into activity by contact with a glutinous body already in an active condition, which may be either yeast or leaven. In this condition it exerts a fermentative influence over the sugar which may either have existed previously in flour, or which is at least immediately developed in it by the influence of moisture. The active gluten splits up each molecule of sugar into two of alcohol, two of carbonic acid, and one of water, and consequently an infinite number of minute air bubbles are developed throughout the fermenting mass. The reaction is shown in the following equation:  $C_6H_{12}O_6 = 2C_2H_5O + 2CO_2 + H_2O$ .

	Carb.	Hyd.	Oxy.	Carb.	Hyd.	Oxy.
1 molecule of Grape Sugar.....				6	14	7
2 molecules of Alcohol.....	4	12	2			
2 " Carbonic Acid .....	2	...	4			
1 " Water .....	...	2	1			
				6	14	7

As the evolution of carbonic acid and alcohol proceeds, the sponge gradually swells, the little bubbles coalesce and enlarge, rising through the tenacious mass till the surface is reached, and then the carbonic acid bursts out and the dough begins to fall. This process would go on a considerable time, but the alcoholic fermentation would soon pass into an acetous fermentation and the sponge would become sour. When acetous fermentation ensues, as not unfrequently happens in baking, it may be remedied to some extent by the addition of bicarbonate of soda to the sponge. The late master of the mint, Dr Thomas Graham, was the first to demonstrate the presence of alcohol in fermented dough, and he thus described his experiment:—"To avoid the use of yeast, which might introduce alcohol, a small quantity of flour was kneaded, and allowed to ferment in the usual way to serve as leaven. By means of the leaven a considerable quantity of flour was fermented, and when the fermentation had arrived at the proper point, formed into a loaf. The loaf was carefully enclosed in a distillatory apparatus, and subjected for a considerable time to the baking temperature. Upon examining the distilled liquid, the taste and smell of alcohol were quite perceptible, and by repeatedly rectifying it, a small quantity of alcohol was obtained, of strength sufficient to burn and to ignite gunpowder by its combustion. The experiment was frequently repeated, and in different bakings the amount of the spirit obtained of the above strength was found to vary from 0·3 to 1 per cent. of the flour employed." Although the temperature of the oven drives off that amount of the spirit, fermented bread is yet found to retain a proportion of alcohol, as much as from 0·221 to 0·401 per cent. having been found in different specimens of baked bread. Speaking in 1858, Dr Odling estimated the amount of alcohol thrown out into the atmosphere from the bread baked in London as equal to 300,000 gallons of spirits annually. Many years ago a patent was secured by a Mr Hicks for collecting and condensing the alcoholic fumes from bakers' ovens, and a company was formed for working the invention. After an expenditure of £20,000 the attempt had to be abandoned, not from any failure to obtain the spirit, but because the bread baked in the process was dry, unpalatable, and unsaleable.

When what is termed "whole wheaten flour"—that is, the entire substance of the grain, excepting only the outer bran—is baked, it is known that the resulting loaf is of a dark brown colour, sweetish in taste, and liable to be somewhat heavy and sodden. The brown colour was at one time supposed to be due to the presence of bran particles in the flour, and in 1846 an American, Mr Bantz, invented a process for removing the outer cuticle of wheat before grinding, it being supposed that the flour so prepared would yield a loaf of white colour, while utilising a larger proportion of the substance of the grain than is commonly used. To the astonishment of experimenters, however, the bread made from such flour was found to have the colour and other characteristics of whole wheaten bread. The subject was investigated by an eminent French chemist, M. Mège Mouriès, who found that the peculiar action of whole wheaten flour was due to the presence in the outer part of the seed of a peculiar nitrogenous body, to which he gave the name cerealin, and which is closely allied in composition and action to the diastase of malt. Cerealin exerts a peculiarly energetic influence on starch, transforming it into a brown adhesive mixture of dextrin and sugar. He showed that when the fermentative action of gluten

preponderates, the result is the formation of the products desired by the baker—carbonic acid and alcohol; but when the influence of cerealin prevails, lactic fermentation ensues, and dextrin, sugar, and acid substances are formed, which it is the object of the baker to avoid. Several methods of avoiding this deteriorating influence of cerealin, and at the same time securing the use of the maximum of flour, have been put in operation by M. Mège Mouriès. The process now in use at the Boulangerie Centrale de l'Assistance Publique (the Scipion) in Paris, for the preparation of the flour and baking white bread with the whole of the mill products excepting the bran, he thus describes:—"The corn is moistened with from 2 to 5 per cent. of water saturated with sea-salt, and at the end of some hours the exterior coverings only become moist and tender. The grain is then thrown between nearly closed millstones, and 70 per cent. of flour is obtained without cerealin, plus 10 to 14 per cent. of meal. This is bruised between light stones, and separated by winnowing from the greater part of the husk remnants. To prepare the bread, all the leaven is made with flour at 70 per cent., and the meal is added to the soft dough last of all, as, in spite of the small amount of cerealin which it still contains, it will not produce brown bread, because at that time the length of incubation is not sufficient to change it into a leaven. Thus white bread is produced containing all the farinaceous part of the wheat."

It not unfrequently happens that flour of good colour, and unexceptionable chemical composition, fails to yield a dough which will rise by fermentation, and the loaf from which is sweet, solid, sodden, and adhesive. Wheat that has been badly harvested, or which in any way has been allowed to sprout, has part of the gluten changed into the form of diastase, which, like cerealin, changes starch into dextrin and sugar. The gluten of flour which has been dried at a too high temperature, and of flour which has been kept in a damp situation, is modified and acts in the same manner. If dough is made with an infusion of malt, it yields a result exactly the same as that above described. It is to guard the starch of inferior flour against this deteriorative influence that a proportion of alum is used by many bakers of second-class bread. Alum has the power of preserving starch to a large extent from the metamorphic action of altered gluten, diastase, or cerealin, and of producing from an inferior flour a loaf of good texture and colour. The use of alum is regarded as an adulteration, and heavy penalties have been imposed on its detection; but its estimation in bread is a process of the greatest difficulty, and authorities are by no means agreed as to its deleterious influence. Other mineral salts have a similar protective power on the starch of inferior wheat, and lime-water has been successfully employed in place of alum. To this also it is objected by some that the addition of lime renders the valuable phosphatic salts of flour insoluble by transforming them into phosphate of lime.

**Aerated Bread.**—When carbonic acid, instead of being generated by fermentation within dough, is separately prepared and incorporated with flour and water, aerated bread is produced. The system by which this is effected was invented by the late Dr Dauglish, and aerated bread has been manufactured under his patent since March 1859. The system is now in operation in all the principal towns in the United Kingdom, and it appears to be steadily gaining in public favour.

The Dauglish apparatus (see fig. 3) consists of the following parts—1st, a generator A, in which carbonic acid is evolved from chalk by sulphuric or hydrochloric acid; 2d, a gas-holder, in which the carbonic acid is stored for use after being purified in passing through water; 3d, an air-pump, for pumping carbonic acid from the gas-holder, and

forcing it into the water vessel and mixer; 4th, another air-pump, for withdrawing atmospheric air from the mixer

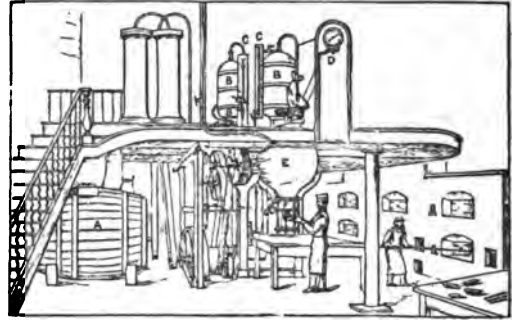

FIG. 3.—Dauglish Apparatus—double set.

before the aerated water is admitted; 5th, a water vessel B, a strong cylinder of copper capable of withstanding a pressure of 100 lb on the square inch, and of sufficient size to contain water for a full charge of the mixer; attached to this water vessel there are a gauge-glass C, and a pressure gauge D, for indicating the pressure of gas as it is pumped in; 6th, the mixer E, a globular vessel of cast-iron, capable of bearing high pressure, through the centre of which an axle runs, fitted with iron kneading-arms extending to the circumference of the vessel. The pumps and the revolving arms within the mixer are worked by steam power. In order to make a sack of flour into dough, a lid at the top of the mixer is opened, and the flour passed down into it through a spout from the floor above. The lid of the mixer is then fitted tightly on, and the air within it exhausted by the pump. The requisite quantity of water, about 17 gallons, is drawn into the water vessel, and carbonic acid is forced into it, till the pressure amounts to from 15 to 25 lb per square inch. The aerated water is then passed into the mixer, and the mixing arms are set in motion, by which, in about seven minutes, the flour and water are incorporated into a perfectly uniform paste. At the lower end of the mixer a cavity F is arranged, gauged to hold sufficient dough for a 2-lb loaf, and by a turn of a lever that quantity is dropped into a pan ready for at once depositing in the oven. The whole of these operations can be performed in less than half an hour. When 4-lb loaves are to be baked the lever has simply to be twice turned. At another part of the lower end of the mixer is placed a pipe G, with a stop-cock, by which dough intended to be fired as Paris bread, on the sole of the oven, is drawn off and weighed before being placed in the oven. The pressure of gas within the mixer is sufficient to force out the whole of the dough, which, immediately on being liberated, swells up by expansion of the gas confined within the tenacious mass. Currant loaves and various kinds of fancy bread are made by the aerated process by placing the necessary ingredients in the mixer along with the flour.

The advantages claimed for Dr Dauglish's process are:—

- "(1.) It does away entirely with fermentation, and with all those chemical changes in the constituents of the flour which are consequent upon it.
- "(2.) It avoids the loss consequent upon the decomposition of the portion of starch or glucose consumed in the process of fermentation, estimated at about 3 to 6 per cent.
- "(3.) It reduces the time requisite to prepare a batch of dough for the oven, from a period of from eight to twelve hours to less than thirty minutes.
- "(4.) Its results are absolutely certain and uniform.
- "(5.) It does away with the necessity for the use of alum with poor flour, and the temptation which bakers are under to use it with all.

"(6.) It has the recommendation of absolute and entire cleanliness, the human hand not touching the dough or the bread from the beginning to the end.

"(7.) The journeymen are relieved from a circumstance most destructive to their health—that of inhaling the flour dust in the process of kneading. . . .

"(8.) It will produce a healthier condition of the baking trade, and thereby diminish to a great extent the inducements which lead to the extensive system of fraud now practised upon the public by the production of adulterated and inferior bread.

"(9.) It will effect an immense saving in the material from another source, namely, by preventing the sacrifice of at least 10 per cent in the nutritive portion of the grain, hitherto lost as human food by the method of grinding and dressing necessary in the preparation of flour for making white bread by fermentation.

"(10.) Together with the preservation of this large proportion of the entire quantity of wheat converted into flour, there is also the important result of the proportion preserved (the cerealin) being a most powerful agent in promoting the easy and healthy digestion of food."

It is objected by opponents of the Daughish system that the product is not really bread, but only an artificial product resembling bread. It is held that the process of fermentation has a specific influence on the constitution of bread, beyond its mechanical effect of rendering the mass spongy or porous. One of the chief hindrances to the more general use of aerated bread is the fact that it is, as compared with fermented bread, insipid and tasteless. In practice, the public have not hitherto derived any advantage from the alleged economy of manufacture, and the suitability of inferior and cheap flour for the process. Although fermented bread is hurtful in some conditions, it is not easy to supplant well-made fermented loaves in general public estimation, and aerated bread can scarcely be said to have hitherto had a fair trial, as with the necessarily expensive machinery a large trade is necessary in order to return a fair profit on the capital invested.

*Unfermented Bread.*—Under this head is included such bread as is vesiculated by means of carbonic acid evolved from chemical substances introduced in the making of the dough. In writing the article on "Baking" for the supplement to the fifth edition of this *Encyclopædia*, published in 1816, Professor Thomas Thomson of Glasgow stated that the only end served by fermentation was the generation of carbonic acid gas, and that this might be accomplished by the use of hydrochloric acid and bicarbonate of soda. About 1842 Mr Henry Dodson commenced to manufacture bread on this system, and obtained a patent for his process. He used hydrochloric acid and bicarbonate of soda in such proportions that while, by their reaction, they liberated sufficient carbonic acid to aerate the dough, they formed chloride of sodium or common salt enough for the bread. Liebig, in his *Familiar Letters*, says regarding this system:—"Chemists, generally speaking, should never recommend the use of chemicals for culinary preparations, for chemicals are seldom met with in commerce in a state of purity. Thus, for example, the muriatic [hydrochloric] acid which it has been proposed to mix with carbonate of soda in bread is always very impure, and very often contains arsenic." The sesquicarbonate of ammonia is also used as a source of carbonic acid in vesiculating bread, and it, on account of its highly volatile nature, is entirely driven off in the process of baking. A great amount of private or domestic baking is conducted on the same principle, butter milk and bicarbonate of soda being used for mixing the dough in making "scones." In this case the lactic acid of the milk combines with the soda, liberating carbonic acid. The baking powders and yeast powders which are sold, and the so-called self-raising flour, all depend for their action on the mixture of bicarbonate of soda with some organic acid, such as tartaric or citric acid.

*Baking Machinery and Ovens.*—The art of baking, al-

though it is the most important of all industries connected with the preparation of human food, is one which is still carried on in the most rude and primitive manner. While modern inventions and the progress of improvement have changed the conditions under which nearly all arts and manufactures are conducted, the baking of bread is still conducted as it was during the palmy days of ancient Greece. The nature of the processes necessary for the preparation of bread, the limited time it will keep, and the consequent impossibility of storing the product or sending it any considerable distance, tend to keep the trade in the position of a limited and local handicraft. It is, therefore, not a pursuit which attracts capitalists, and master bakers are mostly in the position of small tradesmen, without either the inclination or ability to invest money in expensive machinery and fittings. In the case of biscuit-baking the conditions are quite different, and it, as has been seen, has developed into a great manufacture, with elaborate and complex machinery and the most perfect mechanical appliances. Many forms of machine have been proposed as substitutes for the rude and laborious manual labour—always unfavourable to health, and sometimes not very cleanly—involved in baking. Many of these machines admittedly produce better bread than can be made by hand-work, and that at no inconsiderable saving of material and time, but the necessity of either steam or water power for their effective working greatly restricts their use.

The two processes to which machinery has been successfully adapted, are the mixing of the sponge and the kneading of the dough. Attempts have been made to mould loaves by machinery, but these have hitherto failed; nor has the endeavour to fire bread in travelling ovens yet been practically successful. A great variety of kneading machines have been suggested and used, since the first trial of such an implement in Paris upwards of a century ago. The various plans upon which such machines have been constructed will be seen in the accompanying illustrations. Fig. 4 is a form of dough-making machine in common use. It consists of a trough or box, the lower portion of which is semi-cylindrical, hung on a spindle, with a series of iron crossbars revolving inside. It is made to be worked by either hand or steam-power, and of various sizes, as required by bakers. In this machine the whole of the operations connected with setting the sponge, breaking the sponge, and mixing the dough, are performed. The gearing is arranged to give a fast motion for setting the sponge, and a slow motion towards the close of the

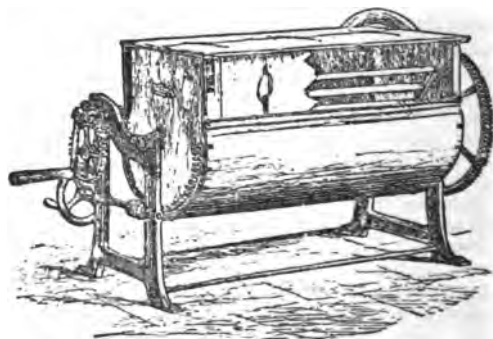

FIG. 4.—Kneading Machine.

dough making, when it is desirable to draw out the mass in order to give it a "skin," or smooth superficial texture. A worm-wheel, working in toothed gearing, tilts over the machine when the process of kneading is complete, and the dough is then conveyed to the scaling and moulding table.

Fig. 5 represents a kneading-machine, of a highly approved form, used in the great Scipion bakery of Paris, the inven-

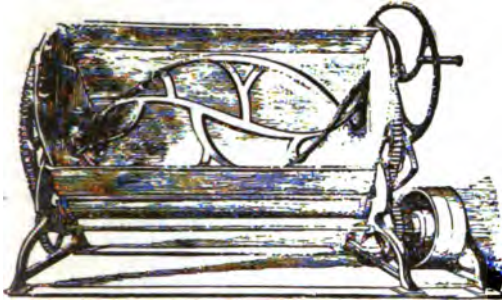

FIG. 5.—Boland's Kneading-Machine.

tion of M. Boland. Externally it is like the former, and it is also geared to move at two rates of rapidity. It has further an adjustment by which the force of the motion is increased while its rate is diminished. The main peculiarity of M. Boland's *pétrin mécanique* consists in the form of the revolving blades inside the trough. These blades are so arranged that they operate when in motion some-

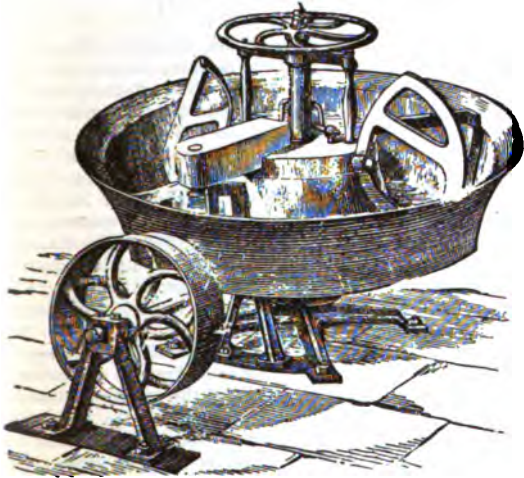

FIG. 6.—Kneading-Machine of Deliry-Desboves.

what like alternate screws, and so toss backward and forward the dough when it is thin, and lift and draw it out when stiff, passing it to each side of the trough alternately. An entirely different form of kneader is seen in fig. 6. This also is of French origin, the invention of M. Deliry-Desboves of Soissons (Aisne). Its construction and operation are thus described:—"The trough is a cast-iron basin, which turns on a vertical axis. The interior is provided with a kneader, shaped like a lyre, which first works up the dough and then divides it during the entire period of operation. Two other implements are also used, of a helical form, to draw out and inflate the dough in all directions, part by part, as is practised in kneading by hand. . . . The baker in charge can regulate the paste without stopping the mechanism. The water and leaven are first introduced, the trough is then set to work, the 'workers' employed to manipulate the dough are put in gear, and the leaven being diluted and flour added, the kneaders are also put in gear. After the lapse of twelve or fifteen minutes the dough is sufficiently kneaded, and, by turning the hand wheel fixed to the screw on the vertical-

shaft, the three kneaders are thrown out of gear. The implement which effects the cleaning of the trough is then removed, and its place supplied by a balance-hook, by which the dough may be weighed in the trough itself. It is simply necessary to turn the basin on its axis as required, until the whole of the dough is weighed."—(Villain, *Études sur l'Exposition de 1867.*)

The fourth form of mechanical kneader we shall describe is that invented by Messrs Vicars of Liverpool, who are extensive makers of all forms of machinery connected with bread and biscuit making. This machine (fig 7) consists

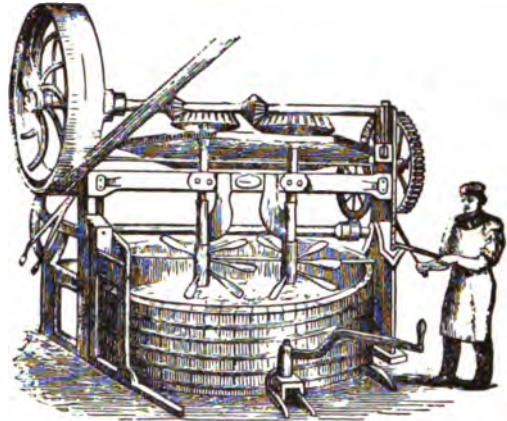

FIG. 7.—Patent Vertical Mixer.

of two vertical shafts, carrying radial arms. These arms pass each other in opposite directions, so that, in addition to a tearing action on the dough, which the knives have on passing each other, they have a screw action, pressing the dough down on one side and up on the other. The vessels containing the dough are made of wood, of an oval form, to correspond with the action of the machine. One considerable advantage connected with Messrs Vicars's machine is, that any number of troughs can be worked by the same pair of mixing shafts, as the troughs are movable, and are raised to, or lowered from, the blades of the mixer by means of friction wheels and spur gear. A baker can thus have several troughs containing sponges in different stages of advancement, all mixed by one pair of shafts, and all in their turn being made into dough by the same shafts.

Much thought and skill have been expended in the endeavour to effect improvements in the ordinary form of a baker's oven, but hitherto no plan has been devised which produces bread of a quality superior to that fired in the oven which is commonly used. A baker's oven of the common description is a low vaulted chamber about 10 feet long, by 8 feet wide, and 30 inches high. It is built and floored of stone or brick, and has a small door in front by which the moulded dough is put in and the loaves withdrawn. At one side of this door, in the extreme corner, are placed the furnace and fire-grate, opening into the oven, and at the opposite corner, the smoke flue by which smoke escapes from the interior. The heat is by this arrangement carried throughout the entire oven, and when the temperature is sufficient the fire is withdrawn, the flue shut, and the dough is quickly introduced on a "peel," or long wooden shovel. Various efforts have been made to effect the heating of ovens by fire external to the chamber itself, but they fail to produce that radiation of heat which is found essential to good baking. Perkin's hot-water oven for some time met with favour in Great Britain, and a modification of it was employed in France.

On this system the oven is heated by superheated water, conveyed from a stove through closed pipes, which are coiled round the entire interior of the oven. This oven has the recommendation of perfect cleanness, and the temperature in it is easily regulated; but it is costly in construction, and the method has not commended itself in practice. Among ovens heated from the exterior, that of M. Rolland takes a high place for ingenuity and novelty of construction. Its characteristic peculiarity consists in the possession of a revolving sole, which not only allows the easy introduction and withdrawal of the bread, but the bringing of the different parts regularly and uniformly under the influence of the heat applied. The revolution of the sole is accomplished by a handle worked from the front of the oven; and besides this rotatory motion the sole can also be raised or lowered so as to bring either the upper or under side of the bread close to the heat as desired. The heating of M. Rolland's oven is effected by means of flues, which pass radially under and over the revolving sole. The chief objection urged against this form of oven is, that the air within it becomes too dry, which detracts from the flavour of the loaves fired in it. The use of the Vienna oven is general in Germany, and is extending in Paris for the baking of small or Vienna bread. It is egg-shaped in form, with an inclined sole, a very small aperture, and a low roof.<sup>1</sup> Its average internal dimensions are 12 feet in depth, 10 feet wide, and 18 inches high. In the best of these ovens glazed tiles are used for the sole. The inclination of the sole facilitates the filling and emptying of the oven; and the confined space of the interior retains a large proportion of moisture, which gives a fine colour to the crust and flavour to the crumb of the bread.

*Qualities of Bread.*—The process of baking changes the structure of the crust or outer part of a loaf, and, according to Reichenbach, develops in it a substance termed *assamar*, which he says has an influence in retarding the waste of tissue. It does not alter the starch of the crumb or internal part, but only swells the granules, and by the induced sponginess of the mass renders it readily digestible. Well-baked bread should have a yellowish-brown crust; the crumb should be uniform in texture, permeated with minute cavities, and without "eyes" or large air-cells. The colour of the crumb, unless in the case of whole wheaten bread, should be white; it should be free from acidity and sourness. It should keep sweet and eatable for several days; and when stale it will be found to become soft and pleasant by again heating it in an oven, after which, however, it rapidly changes. According to Dr Frankland's determinations, "1 lb of the crumb of bread, if digested and oxidised in the body, will produce an amount of force equal to 1333 tons raised 1 foot high. The maximum of work which it will enable a man to perform is 267 tons raised 1 foot high. 1 lb of crumb of bread can produce, at the maximum,  $1\frac{1}{16}$  oz. of dry muscle or flesh."

The adulteration of bread, and its detection, are treated under the heading ADULTERATION vol. i. p. 170. (J. P.A.)

BAKU, or BAKU, the chief town of the government of the same name, in the Russian province of Transcaucasia (Daghestan), situated in the peninsula of Apsheron, on the west coast of the Caspian, and possessing one of the most spacious and convenient ports in that sea. Long. 49° 53' E., lat. 40° 23' N. It is built in the form of an obtuse triangle, on the slope of an arid hill, and is defended by a double wall and ditch constructed during the reign of Peter the Great. The general appearance of the town is decidedly Oriental, with its flat-roofed houses rising one behind the other, often in so close proximity that the top of the one

<sup>1</sup> The Vienna oven is figured in Knapp's *Technology*, vol. III. p. 102.

forms the courtyard of the next. The hill is crowned by a castle, which dates from the 15th century, and the mosque of Shah-Abbas, still in good preservation. At the entrance of the harbour stands the Maiden's Tower, now used as a lighthouse, which derives its name from a tragedy like that of the Cenci. Baku is not only a principal station of the Russian fleet, but it carries on a very extensive trade, exporting naphtha, iron, linen, and woollen goods, and receiving in return cotton, grain, fruits, &c. The numerous naphtha wells in the neighbourhood, and the remarkable escape of inflammable gases, rendered Baku a favourite resort of the fire-worshippers, who for long maintained their temples in the district; but, though the natural phenomena display themselves as abundantly as ever, they are now almost entirely deserted by devotees. The Arabian Masudi, in the 10th century, is supposed to be the first to mention "Baki" and its fire-breathing mountain; and the naphtha wells are probably those alluded to by Marco Polo. In 1509 it was taken by the Persians, who lost it to the Turks, but recovered it under Shah-Abbas. Captured by the Russians in 1723, it was restored to Persia in 1735, but after various vicissitudes it was finally incorporated with the Russian empire in 1806. (See Goldschmid's *Telegraph and Travel*, 1874; Filippi's *Viaggio in Persia*, 1865; *Hist. des découvertes faites par div. sav. voyageurs*, Lausanne, 1784; *La Tour du Monde*, 1863; "Baku" in *Zeitschrift der Deutsch. Geol. Gesellschaft*, 1874.)

BALA, a market-town of Wales, county of Merioneth, and hundred of Penllyn, at the northern extremity of the lake of the same name, 17 miles N.E. of Dolgelly. It consists principally of one wide street. Its manufactures are flannels, stockings, gloves, and other woollen hosiery. There is an endowed grammar school, founded in 1712, and a theological college, belonging to the Calvinistic Methodists. The Rev. Thomas Charles, well known in connection with the religious literature of his country, was long a minister at Bala. Population, 1539. The Lake of Bala, which is 4 miles long and about half a mile broad, is subject to sudden and sometimes dangerous floods. It is very deep and clear, and abounds with pike, perch, trout, eels, and the *gwyniad*, or *Corygonus fera*.

BALAAM, or rather BILHEAM, the son of Beor, belonging to Pethor, by the River Euphrates in Aram, is represented in Scripture as a seer who possessed the power of blessing and cursing effectually. According to the narrative in Numbers xxii.—xxiv., he was invited by Balak, king of Moab, to come and curse Israel, in order to ensure the latter's defeat. Jehovah, however, forbade him to go as he was requested, and therefore he refused to accompany the deputation of elders, who had been sent to invite him, "with the rewards of divination in their hand." After the arrival of a second embassy more imposing than the first, he received divine permission to go, but only on condition that he should adhere strictly to what Jehovah should tell him. He set out accordingly, and in his journey experienced the anger of the Lord, an angel being sent to stop his progress, who was perceived only by the ass on which the prophet was riding. After Balaam's eyes had been opened he saw the angel, and declared his willingness to go back, but received permission to continue his journey on condition of saying nothing but what was suggested to him by God. His reception by Balak was honourable and imposing, yet he continued faithful to Jehovah, and told the king he would only announce what Jehovah revealed. Standing on the height of Baal-Bamoth, and surveying the tents of Israel, he declared his inability to curse a people so peculiar and righteous. Brought next to the top of Pisgah, and beholding thence a part of the Israelite camp, he announced that Jehovah saw no iniquity or perverseness in Jacob; that He was with them; that they were therefore strong and

victorious. Conducted afterwards to the top of Peor, he surveyed the army of Israel, and predicted their future, their goodly dwellings in Canaan, and their successful wars against the nations down to Saul's time. Though Balak was angry and interrupted him, Balaam continued his prophecy, announcing Israel's valiant deeds, from David down to Hezekiah. Upon this he returned to his home.

Another account of Balaam appears in Numbers xxxi. 8-16, Joshua xiii. 22, where we learn that he advised the Midianite women to seduce the Israelites to the licentious worship of Baal, and that he was slain in a war with the Midianites.

The character given to Balaam in the first account is a favourable one. He is a worshipper of Jehovah the true God, receives divine revelations, and repeatedly declares that he will not go beyond or against them. Faithful to his calling, he steadfastly resists temptations sufficiently powerful, and therefore God communicates His Spirit to him, enabling him to predict the future of Israel.

The second account is unfavourable. In it he appears as a diviner, *ḥāzān*, a heathen seer, who tempted the worshippers of the true God to idolatry. Instead of being a prophet of Jehovah, receiving visions and revelations, a man to whom the Almighty came by night, giving him instructions what to do, he is an immoral soothsayer. Of the two accounts, the latter, brief as it is, seems entitled to greater consideration. The former is elaborate and artificial, the theme being the glorification of the chosen people by the mouth of one of their enemies. An inspired seer from the far distant land of Aram is called in to bless the Israelites. He does so reluctantly, but like a true prophet, announcing nothing but what came to pass. The way in which he is taught the high destiny of the chosen people is instructive. Ignorant at first of Israel's relation to the true God, and thinking they were like others, he was disposed to curse them, but is enlightened, and forcibly impelled to follow the divine revelations. From a heathen *mantis* he is converted into a true prophet by revelations and visions which he cannot resist. The seer is taken to three places in succession, whence he surveys Israel, and utters oracular sayings concerning them. Three times the angel of the Lord stands in the way, and three times the ass is smitten by Balaam. There are four prophetic announcements—xxiii. 7-10, 18-24; xxiv. 3-9, 15-24. The first refers to the separate condition of Israel, their numbers, and their worship of the true God amid the idolatry of the surrounding nations. The second declares that God blesses Israel because there is no iniquity or perverseness in them, that He dwells among them, reveals himself to them, and makes them powerful and victorious. Both these refer to Mosaic times, or at least to times not later than Joshua. But the third announcement has the character of prediction, and refers to future events. Hence Balaam is introduced as a man whose eyes are opened, who hears the words of God, and sees visions of the Almighty. The condition of the people down to the time of Saul is glanced at, their secure settlement in Canaan, and victorious wars with the native races. The fourth prophecy apparently carries down the history to the time of Hezekiah; and a future ruler is distinguished as the star out of Jacob, the sceptre out of Israel, the conqueror of the Moabites and Edomites. The mention of the Kenites and Assyria in ver. 22, the former of whom were allies of Edom, shows, in the opinion of some recent critics, that the writer was acquainted with the Edomite wars under Amasiah and Uziah, and hoped that the latter power would permanently subjugate the restless Edomites. This would bring the composition down to the first half of the 8th century. Verses 23 and 24 are obscure, but probably refer to no event later than

Hezekiah. A fleet from the Phœnician Cyprians seems to have attacked the Canaanitish and Phœnician coasts, threatening the Syrians farther north.

The writer of Num. xxxi. 8, 16, Joshua xiii. 22, is the Elohist, whose account is very brief. Meagre, however, as it is, it is probably historical. A heathen soothsayer, connected with the Midianites, perished in one of their battles with Israel. The writer of Numbers xxii.-xxiv. is, in this view, the Jehovist, who, under the name of Balaam, gives expression to his ideas and hopes in the elevated diction of an inspired prophet. As Jacob and Moses had pronounced blessings on Israel under the immediate inspiration of the Almighty, so Balaam is summoned from a distant land to eulogise the same people.

The character of Balaam has been apprehended very variously. Such diversity must exist according as the Elohist or Jehovist is followed. The Old Testament writers who mentioned him afterwards were influenced by the Jehovistic notice, and pronounce no judgment upon the seer (Deut. xxiii. 5, 6; Joshua xxiv. 9, 10; Micah vi. 5; Nehemiah xiii. 2); but the New Testament authors followed the Elohist account, and speak of him disparagingly, attributing to him love of "the wages of unrighteousness," madness, idolatrousness, and impiety (2 Peter ii. 15, 16; Jude 11; Rev. ii. 14). Josephus calls him *μάντις ἀπίστος τῶν τότῃ*, "the best prophet of his time," supposing him to be a prophet of the true God, but with a disposition ill-adapted to resist temptation. Philo describes his character more critically: "There was a man at that time celebrated for divination, who lived in Mesopotamia, and was an adept in all the forms of the divining art; but in no branch was he more admired than in surgery; to many persons, and on many occasions, he gave great and astounding proofs of his skill. For to some he foretold storms in the height of summer; to others drought and heat in the depth of winter; to some scarcity succeeding a fruitful year, and then again abundance after scarcity; to others the overflowing and drying up of rivers, and the remedies of pestilential diseases, and a vast multitude of other things, each of which he acquired great fame for predicting." The unfavourable character drawn of him by Philo is that which is generally taken by the later Jews. The later Targumists call him a sinner and an accursed man, while the Talmudists make him the representative of the godless, in contrast with Abraham, the representative of the pious. Yet they do not ignore his prophetic gift. The Midrashim about him are hardly worth mentioning, such as that he was one of Pharaoh's counsellors, that he was governor of a city in Ethiopia which he excited to rebellion, but was unable to defend against Moses at the head of an army who stormed the place and put Balaam to flight. In Yalkut (§ Shemoth) he is said to have been identified by some with Laban, Jacob's father-in-law; by others with Elihu, Job's friend; while others say that Jannes and Jambres were his sons. In Sanhedrin (§ Chelek) he is said to have been blind of an eye. These, and other rabbinical fables, are entirely worthless; and Origen's belief that the Magi from Persia, who came to worship the infant King of the Jews, learnt the meaning of the star from Balaam's prophecies, is of the same character.<sup>1</sup>

Most of the Fathers, including Augustine and Ambrose, judged him to be a soothsayer or magician, a prophet inspired by the devil. A few, as Tertullian and Jerome, took a more favourable view of his character. The Mahometans have various fables concerning Balaam. They say that he was of the race of Anakim, or giants of Palestine, and that he read the books of Abraham, where he got the name Jehovah, by virtue of which he predicted the

<sup>1</sup> See Fabricius's *Codex Pseudepigraphus Vet. Test.*, p. 807, &c.

future, and got from God whatever he asked. This procured him great renown. In consequence, however, of his prevarication, God was offended with him, and left him to himself, so that he fell into infidelity. It is generally supposed that the words in the Koran (§ Al-Araf) refer to him:—"The history of him unto whom we brought our signs and he departed from them; wherefore Satan followed him, and he became one of those who were seduced. And if we had pleased, we had surely raised him thereby unto wisdom; but he inclined unto the earth, and followed his own desire. Wherefore his likeness is as the likeness of a dog, which, if thou drive him away, putteth forth his tongue; or if thou let him alone, putteth forth his tongue also."

It has been conjectured with much probability that the Arabic wise man, commonly called Lokman, is identical with Balaam. The two names coincide in meaning, *devourer, swallower*; and the names of their fathers are also alike. The Jews suppose Balaam to have been a Nahorite, and so Lokman is regarded by many Arabic authors, though the more general opinion is that he was an Abyssinian slave who lived in the time of David, and was renowned as a Hakim. The proverbs or fables attributed to him are of Greek origin.

Modern critics are divided in opinion respecting him. Three leading views embrace the varieties of belief as to his true position, viz., that he was an idolater and soothsayer, whose soul was uninfluenced by true religion—a sorcerer who had acquired reputation by his insight into the force of nature and his incantations; that he was a true prophet of God, a pious man who fell through covetousness; and that he was a heathen soothsayer and a prophet of Jehovah at the same time, occupying an intermediate position, with an incipient knowledge and fear of God, needing but to be developed, though checked by the love of gain. It appears impossible to arrive at a definite or comprehensive view of one who is described in different sources inconsistently. Bishop Butler, not recognising that the history of Balaam has poetical elements, and that different traditions are given respecting him, considers him a very wicked man under a deep sense of God and religion, persisting still in his wickedness, and preferring the wages of unrighteousness even when he had before him a lively view of death. His mind was distracted by contradictory principles of action. All we know about him amounts to very little. After admitting that a heathen soothsayer of this name existed in Mesopotamia, and had acquired some renown in the regions adjoining, and that he was employed in some way as a medium for uttering eulogiums upon Israel, of whose pre-eminence and permanence he is fully conscious, nothing else can be affirmed with certainty. (Davidson's *Introduction to the Old Testament*, vol. i. p. 328, &c.; Ewald's *Geschichte des Volkes Israel*, zweyter Band, p. 298, &c., 3d edition, and his *Jahrbücher*, part 8, p. 1, &c.; Kurtz's *Geschichte des alten Bundes*, zweyter Band, p. 454, &c.; Hengstenberg's *Die Geschichte Bileam's und seine Weissagungen*, 1842; Winer's *Realwörterbuch*, s.v. "Bileam;" Knobel's *Die Bücher Numeri, Deuteronomium, und Josua erklärt*, p. 121, &c.; Schenkel's *Bibel-Lexicon*, s.v. "Bileam;" and Hamburger's *Real-Encyclopædie für Bibel und Talmud*, s.v. "Bileam.")

BĀLĀGHĀT, a British district in the Central Provinces of India, situated between 21° and 23° N. lat. and 80° and

81° E. long.; bounded on the N. by the district of Mandlā; on the E. by the district of Chhattisgarh; on the S. by Chhattisgarh and Bhandārā; and on the W. by the district of Seoni. Bālāghāt forms the eastern portion of the central plateau which divides the province from east to west. These highlands, formerly known as the Rāigarh Bichhiā tract, remained desolate and neglected until 1866, when the district of Bālāghāt was formed, and the country opened to the industrious and enterprising peasantry of the Waingangā valley. Geographically the district is divided into three distinct parts:—(1.) The southern lowlands, a slightly undulating plain, comparatively well cultivated, and drained by the Waingangā, Bāgh, Deo, Ghisri, and Son rivers. (2.) The long narrow valley, known as the Mau Talukā, lying between the hills and the Waingangā river, and comprising a long, narrow, irregular-shaped lowland tract, intersected by hill ranges and peaks covered with dense jungle, and running generally from north to south. (3.) The lofty plateau, in which is situated the Rāigarh Bichhiā tract, comprising irregular ranges of hills, broken into numerous valleys, and generally running from east to west. The highest points in the hills of the district are as follows:—Peaks above Lānjī, 2300 or 2500 feet; Tepāgarh hill, about 2600 feet; and Bhainsāghāt range, about 3000 feet above the sea. The principal rivers in the district are the Waingangā, and its tributaries, the Bāgh, Nahrā, and Uskāl; a few smaller streams, such as the Maamār, the Māhkārā, &c.; and the Banjār, Hālon, and Jamuniā, tributaries of the Narbadā, which drain a portion of the upper plateau. Bālāghāt contains very extensive forests, but they do not produce timber of any great value. They teem with wild animals, from the great bison to the fox; 470 beasts and venomous snakes were killed in 1867-68, a total reward of £156 being paid under this head. The district contained in 1868 an assessed area of 1462·08 square miles or 935,731 acres, of which 214,587 acres were under cultivation; 488,510 grazing lands; 116,938 culturable, but not actually under cultivation; 115,696 unculturable waste. The census report of 1872 returned the area at 2608 square miles. The census of 1866 showed a population of 170,964. This had in 1872 increased to 195,008, residing in 37,192 houses and 781 villages; average number of persons per square mile, 74·77; per village, 249·69; per house, 5·24. Of the total population, 131,176 or 67·27 per cent. were Hindus; 2934 or 1·50 per cent. Mahometans; 39 Buddhists; 11 Christians; 60,848 or 31·20 per cent. of unspecified religions of aboriginal or imperfectly Hinduised types.

Since 1867 considerable encouragement has been given to the cultivating tribes of Ponwārā, Kunbā, Marā, &c., of the low country to immigrate, and take up lands in the upland tracts. By this means a large quantity of junglo lands has lately come under cultivation. The acreage under the principal crops grown in the district is returned as follows:—rice, 188,312 acres; wheat, 585; other food grains, 8770; oil-seeds, 3436; sugar, 505; fibres, 100; tobacco, 638; total, 202,346 acres. Iron is smelted by the Gonds; gold exists in the beds of some of the rivers, but not in sufficient quantities to repay the labour of washing. There are no regularly made roads in the district. Five passes lead from the low country to the highlands, viz., the Bānpur Ghāt, the Warai Ghāt, the Pancherā Ghāt, the Bhondwā Ghāt, and the Ahmadpur Ghāt. For revenue purposes the district is divided into two subdivisions, the Būrhā Tahsil and the Paraswārā Tahsil. In 1868-69 the total revenue of the Bālāghāt district amounted to £11,746, of which £6754, or 57 per cent., was from land. For the protection of person and property, Government maintained, in 1868, 115 policemen, at a total cost of £1150, 16s. In 1868 only two towns in the dis-

<sup>1</sup> בלעם from בלע, with the formative letter ע. It has been derived from בלע-בלע (Sanhed. 105), *destroyer or corrupter of the people*, so that the name has passed for a typical designation of Israel's enemy; and this is reflected in the Greek word Νικολαίτης (Rev. ii. 6), from νικᾶν and ἄσος, as if the Nicolaitanes were essentially Balaamites, or seducers. But this etymology of the name Balaam is improbable.



trict had upwards of 2000 inhabitants, viz., Hattā, population, 2808, and Lanjī, population, 2116. About 60 years ago the upper part of the district was an impenetrable waste. About that time one Lachman Naik established the first villages on the Paraswārā plateau, on which there are about 30 flourishing settlements. But a handsome Buddhist temple of cut stone, belonging to some remote period, is suggestive of a civilization which had disappeared before historic times.

**BALANCE.** For the measurement of the "mass" of (i.e., of the quantity of matter contained in) a given body we possess only *one* method, which, being independent of any supposition regarding the nature of the matter to be measured, is of perfectly general applicability. The method—to give it at once in its customary form—consists in this, that after having fixed upon a *unit mass*, and procured a sufficiently complete set of bodies representing each a known number of mass-units (a "set of weights"), we determine the ratio of the *weight* of the body under examination to the *weight* of the unit piece of the set, and identify this ratio with the ratio of the *masses*. Machines constructed for this particular *modus* of weighing are called *balances*. Evidently the weight of a body as determined by means of a balance—and it is in this sense that the term is always used in everyday life, and also in certain sciences, as, for instance, in chemistry—is independent of the magnitude of the force of gravity; what the merchant (or chemist) calls, say, a "pound" of gold is the same at the bottom as it is at the top of Mont Blanc, although its real weight, i.e., the force with which it tends to fall, is greater in the former than it is in the latter case.

To any person acquainted with the elements of mechanics, numerous ideal contrivances for ascertaining which of two bodies is the heavier, and for even determining the ratio of their weights, will readily suggest themselves; but there would be no use in our noticing any of these many conceivable balances, except those which have been actually realised and successfully employed. These may be conveniently arranged under six heads.

1. *Spring Balances.*—The general principle of this class of balances is that when an elastic body is acted upon by a weight suspended from it, it undergoes a change of form, which, *ceteris paribus*, is the greater the greater the weight. The simplest form of the spring balance is a straight spiral of hard steel (or other kind of elastic) wire, suspended by its upper end from a fixed point, and having its lower end bent into a hook, from which, by means of another hook crossing the first, the body to be weighed is suspended,—matters being arranged so that even in the empty instrument the axis of the spiral is a plumb-line. Supposing a body to be suspended at the lower hook, it is clear that the point where the hooks intersect each other will descend from the level it originally occupied, and that it must fall through a certain height  $h$  before it can, by itself, remain at rest. This height, provided the spiral was not strained beyond its limit of elasticity (i.e., into a permanent change of form), is proportional to the *weight*  $P$  of the body, and consequently has to the mass  $M$  the relation  $h = c/M$ , where  $c$  is a constant and  $g$  the acceleration of gravity. Hence, supposing in a first case  $h$  and  $M$  to have been  $h'$  and  $M'$ , and in a second case,  $h''$  and  $M''$ , we have  $h' : h'' :: gM' : gM''$ ; and it is only as long as  $g$  is the same that we can say  $h' : h'' :: M' : M''$ . Spring balances are very extensively used for the weighing of the cheaper articles of commerce and other purposes, where a high degree of precision is not required. In this class of instruments, to combine compactness with relatively considerable range, the spring is generally made rather strong; and sometimes the exactitude of the reading is increased by inserting, between the index and that point the displacement of which serves

to measure the weight, a system of levers or toothed wheels, constructed so as to magnify into convenient visibility the displacement corresponding to the least difference of weight to be determined. Attempts to convert the spring balance into a precision instrument have scarcely ever been made; the only case in point known to the writer is that of an elegant little instrument constructed by Professor Jolly, of Munich, for the determination of the specific gravity of solids by immersion, which consists of a long steel-wire spiral, suspended in front of a vertical strip of silvered glass bearing a millimetre scale. To read off the position of equilibrium of the index on the scale, the observing eye is placed in such a position that the eye, its image in the glass, and the index are in a line, and the point on the scale noted down with which the index apparently coincides.

2. *Chain Balances.*—This invention of Wilhelm Weber's having never, so far as we know, found its way into actual practice, we confine ourselves to an illustration of its principle. Imagine a flexible string to have its two ends attached to the two fixed points C and D (fig. 1), forming the ter-

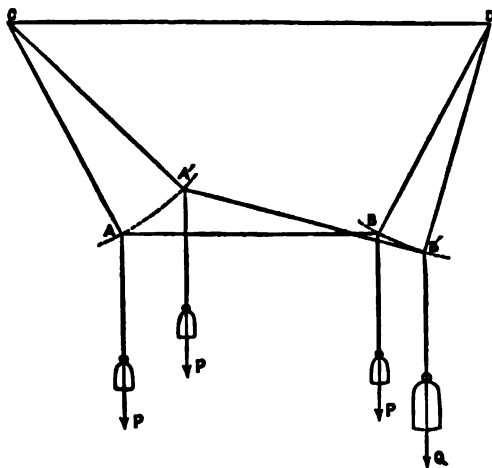

FIG. 1.—Diagram Illustrating Chain Balance.

minal points of a horizontal line CD shorter than the string. Suppose two weights to be suspended, the one at a point A, the other at a point B of the string; the form of the polygon CDBA will depend, *ceteris paribus*, on the ratio of the two weights. Assuming, for simplicity's sake, CA to be equal to DB, then, if the weights are equal, say, each =  $P$  units, the line AB will be horizontal. But if now, say, the weight at B be replaced by a heavier weight Q, the point A will ascend through a height  $h$ , the point B will descend through a lesser height  $h'$  in accordance with equation  $PA = Qh'$ , and the angle between what is now the position of rest of the base line A'B', and the original line AB will depend on the ratio of  $P : Q$ . The exact measurement of this angle would be difficult, but it would be easy to devise very exact means for ascertaining whether or not it was horizontal, and, if not, whether it slanted down the one way or the other; and thus the instrument might serve to determine whether P was equal to, or greater or less than, Q; and this obviously is all that is required to convert the contrivance into an exact balance.

3. *Lever Balances.*—This class of balances, being more extensively used than any other, forms the most important division of our subject. There is a great variety of lever balances; but they are all founded upon the same principles, and it is consequently expedient to begin by summing up these into one general theory.

*Theory of the Lever Balance* (fig. 2).—In developing the "theory" of a machine, the first step always is and must be that we substitute for the machine as it is a *fictitious* machine, which, while it closely corresponds in its working to the actual thing, is free from its defects. In this sense what now follows has to be understood. Imagine

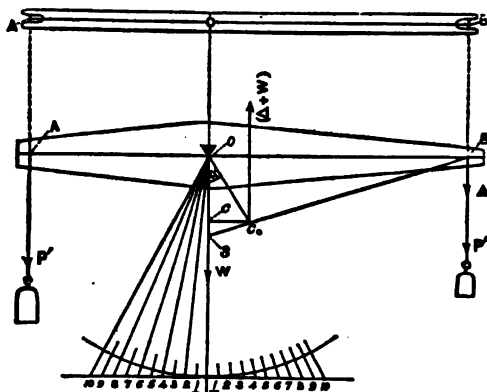

FIG. 2.—Diagram illustrating the theory of the Lever Balance.

an *inflexible* beam suspended from a stand in such a manner that, while it can rotate freely about a certain horizontal axis fixed in its position with respect to both the stand and the beam, and passing through the latter somewhere above its centre of gravity, it cannot perform any other motion. Imagine the beam at each end to be provided with a vertical slit, and each slit to be traversed by a rigid line fixed in the beam in such a situation that both lines are parallel to, and in one and the same plane with, the axis of rotation; and suppose the mass of the beam to be so distributed that the line connecting the centre of gravity S with its projection O on the axis of rotation stands perpendicular to that plane. Suppose now two weights, P' and P'', to be suspended by means of absolutely flexible strings, the former from a point A on the rigid line in the left, the other from a point B on the rigid line in the right slit, and clearly, whatever may be the effect, it will not depend on the length of the strings. Hence we may replace the two weights by two material points situated in A and B, and weighing P' and P'' respectively. But two such points are equivalent, statically, to one point (weighing P' + P'') situated somewhere in D within the right line connecting A with B. Suppose the beam to be arrested in its "normal position" (by which we mean that position in which AB stands horizontal and the line SO is a plumb-line), and then to be released, the statical effect will depend on the situation of the point D, and this situation, supposing the ratio l' : l'' to be given, on the ratio P' : P''. If P' l' = P'' l'', D lies in the axis of rotation; the beam remains at rest in its normal position, and, if brought out of it, will return to it, being in *stable* equilibrium. This at once suggests two modes of constructing the instrument and two corresponding methods of weighing.

*First Method.*—We so construct our instrument that while l' is constant, l'' can be made to vary and its ratio to l' be measured. In order then to determine an unknown weight P', we suspend it at the point pivot A; we then take a standard weight P'' and, by shifting it forwards and backwards on AB, find that particular position of the point of suspension B, at which P'' exactly counterpoises P'. We then read off  $\frac{l''}{l'}$ , and have  $P' = P'' \frac{l''}{l'}$ . But, practically, the body to be weighed cannot be directly suspended from A, but must be placed in a pan suspended from A, and consequent-

ly the weight p, of the pan and its appurtenances would always have to be deducted from the total weight P', as found by the experiment, to arrive at the weight of the object  $p = P' - p_0$ . Hence, what is actually done in practice is so to shape the right arm that its back coincides with the line AB, and to lay down on it a scale, the degrees of which are equal to one another, and to l' (or some convenient sub-multiple or multiple of l') in length, and so to adjust p<sub>0</sub> and number the scale, that when the sliding weight P'' is suspended at the zero-point, it just counterpoises the pan; so that when now it is shifted successively to the points 1, 2, 3 . . . p, it balances exactly 1, 2, 3 . . . p units of weight placed in the pan. This is the principle of the common *steel-yard*, which, on account of the rapidity of its working, and as it requires only one standard weight, is very much used in practice for rough weighings, but which, when carefully constructed and adjusted, is susceptible of a very considerable degree of precision. In the case of a precision steel-yard, it is best so to distribute the mass of the beam that the right arm balances the left one + the pan, to divide that arm very exactly into, say, only 10 equal parts, and instead of one sliding weight of P'' units to use a set of standards weighing  $\frac{1}{10} P''$ ,  $\frac{2}{10} P''$ ,  $\frac{3}{10} P''$ ,  $\frac{4}{10} P''$ , &c. The great difficulty is to ensure to the heavier sliding weights a sufficiently constant position on the beam. To show the extent to which this difficulty can be overcome it may be stated that in an elegant little steel-yard, constructed by Mr Westphal of Calle (for the determination of specific gravities), which we had lately occasion to examine, even the largest rider, which weighs about 10 grammes, was so constant in its indications that, when suspended in any notch, it always produced the same effect to within less than  $\frac{1}{10000}$ th of its value.

*Second Method.*—We so construct our instrument that both l' and l'' have constant values, and are nearly or exactly equal to each other, and provide it with pans, whose weights p'<sub>0</sub> and p''<sub>0</sub> are so adjusted against each other that p' l' = p'' l'', and, consequently, the empty instrument is at rest in its normal position. We next procure a sufficiently complete set of weights, i.e., a set which, by properly combining the several pieces with one another, enables us to build up any integral multiple of the smallest difference of weight δ we care to determine, a set, for instance, which virtually contains any term of the series 0.001, 0.002, 0.003 . . . . . 100.000 grammes. In order now to determine an unknown weight p', we place it, say, in the left pan, and then, by a series of trials, find that combination of standards p'' which, when placed in the right pan, establishes equilibrium to within ± δ. Evidently—

$$p' = \frac{(p'' \pm \delta) l''}{l'} \dots \dots \dots (1).$$

In the case of purely *relative* weighings, there is nothing to hinder us from adopting  $\frac{l''}{l'}$  units (e.g.,  $\frac{l''}{l'}$  grammes) as our unit of mass, and simply to identify the relative value of p' with the number p''. But even if we want to know the absolute value of p' in true grammes, we need not know the numerical value of  $\frac{l''}{l'}$ . All we have to do is, after

having determined the value of p' in terms of  $\frac{l''}{l'}$ , to reverse the positions of object and standards, and, in a similar manner, to ascertain the value p'' which now counterpoises the unknown weight p' lying in the *right* pan. Obviously  $p' = p'' \frac{l''}{l'} = p_1'' \frac{l''}{l'}$  whence  $(p')^2 = p'' p_1''$ , and  $p' = \sqrt{p'' p_1''}$ , for which expression, if the two arms are very nearly of equal length, we may safely substitute  $p' = \frac{1}{2}(p'' + p_1'')$ . Or, instead of at once finding the counterpoise for p' in standards, we may first counterpoise it by means of shot or other

material placed in the opposite pan, and then find out the number of grammes  $p''$  which has to be substituted for  $p'$  to again establish absolute equilibrium. Evidently  $p' = p''$ . This (in reference to the ideal machine meant to be realised) is the theory of the *common balance* as we see it working in every grocer's shop, and also that of the modern *precision balance*, which, in fact, is nothing but an equal-armed beam and scales refinedly constructed. In the case of the latter class of balances the inconvenience involved in the use of very small weights may be avoided (and is generally avoided) by dividing the right arm of the beam, or rather the line AB, into 10 equal parts, and determining differences of less than, say, 0.01 grammes by means of a sliding weight possessing that value. But evidently, instead of dividing the whole length of the right arm, it is better to divide some portion of it which is so situated that the rider can be shifted from the very zero to the "10," and so to adjust the rider, that when it is shifted successively from 0 to 1, 2, 3 . . .  $n$  it is the same as if 1, 2, 3 . . .  $n$  tenths of its weight were placed in the right pan. The rider in this case must, of course, form part and parcel of the beam. It is singular that none of our precision-balance makers have ever thought of this very obvious improvement on the customary system. In the very excellent instrument made by Messrs Becker and Company of New York, this, it is true, is realised partially in a rider weighing 12 milligrammes and a beam divided into 12 equal parts (instead of 10 and 10 respectively); but this does not enable one to shift the rider to where it would indicate from 0 to say  $\frac{1}{10}$  or  $\frac{1}{100}$  of a milligramme. Whichever of these modes of weighing we may adopt, we must have an arrangement to see whether the balance is in its normal position, and it is desirable also to have some means to enable us, in the course of our trials, to form at least an idea as to the additional weight which would have to be added to the standards on the pan (or to be taken away) in order to establish equilibrium. To define the normal position, all that is required is to provide the beam with a sufficiently long "needle," the axis of which is parallel to the line OS, and which plays against a circular limb fixed to the stand and constructed so that the upper edge of the limb coincides very nearly with the path of the point of the vibrating needle, and to graduate the limb so that, as fig. 2 shows, the zero point indicates the normal position of the beam. In order to see how the graduation must be made to be as convenient as possible a means for translating deviations of the needle into differences of weight, let us assume the balance to be charged with  $P'$  grammes from A and with  $P'' + \Delta$  grammes from B, and  $P'$  and  $P''$  to satisfy the equation  $P' l = P'' l'$ . The two weights  $P'$  and  $P''$  being equivalent to one point  $P + P'$  in the axis of rotation, the effect is the same as if these two weights did not exist and the beam was only under the influence of two weights, viz., the weight  $W$  of the beam acting in S and the weight  $\Delta$  acting in B. But this comes to the same as if both  $W$  and  $\Delta$  were replaced by one point weighing  $W + \Delta$ , and situated somewhere at  $C$ , between, and on a line with, B and S. Hence, supposing the beam to be first arrested in its normal position and then to be left to itself, the right arm will go down and not be able by itself to remain at rest before it has reached that position in which  $C$ , lies vertically below the axis of rotation. *Ceteris paribus*  $C$ , will be the nearer to B, and consequently the angle  $\alpha$ , through which the beam (and with it the needle) has to turn to assume what now is its position of stable equilibrium, will be the greater the greater  $\Delta$  is, and for the same  $\Delta$  and  $W$  the angle of deviation will be the greater the less the distance  $s$  of the centre of gravity of the beam S is from the axis of rotation. The former proposition enables one in a given case to form an idea of the amount  $\Delta$  which has to be taken away from the

right pan to establish equilibrium. To find the exact mathematical relation between  $\Delta$  and the corresponding angle  $\alpha$ , let us remember that the position of  $C$ , is the same whatever may be the direction of gravity with regard to the beam. Assuming gravity to act parallel to OS, we have  $(W + \Delta) OC = \Delta l'$ , where C stands for the projection of  $C$ , on OS. Assuming, secondly, gravity to act parallel to the line OB, we have  $(W + \Delta) l \sin \alpha = W OS$ ;  

$$\therefore \frac{OC}{CO} = \tan \alpha = \frac{\Delta l'}{W s} \dots (2).$$

Obviously, the right way of graduating the limb is to place the marks so that their radial projections on the tangent to the circle at the zero-point divide that line into parts of equal length. In the ordinary balance where  $l'$  is a constant, the factor  $\frac{l'}{W s}$  has a constant value, which can be determined by one experiment with a known  $\Delta$ —always supposing that in the instrument used the requirements of our theory were exactly fulfilled. In good precision balances they are fulfilled, to such an extent at least, that although the factor named is not absolutely constant, but a function of  $P$ , it can be looked upon as a *relative* constant, so that by determining the deviations produced by a given  $\Delta$ , say  $\Delta = 1$  milligramme, for a series of charges (i.e., values of  $P'$ ), one is enabled to very readily convert deviations of the needle, as read off on the scale, into differences of weight. This method is very generally followed in the exact determinations of weights as required in chemical assaying, in the adjusting of sets of weights, &c. Only, instead of letting the needle come to rest and then reading off its position, what is done is to note down 2, 3, 4 . . .  $n$  consecutive excursions of the needle, and from the readings ( $a_1, a_2, a_3, a_4, \dots a_n$ ) to calculate the position  $a$ , where the needle would come to rest if it were allowed to do so. It being understood that the readings must be taken as positive or negative quantities according as they lie to the left or to the right of the zero-point,  $a$ , might be identified with any of the sums—

$$\frac{1}{2} (a_1 + a_n), \frac{1}{2} (a_2 + a_{n-1}), \dots \frac{1}{2} (a_{n-1} + a_2),$$

but clearly it is much better to calculate  $a$ , by taking the mean of these quantities, thus—

$$a = \frac{a_1 + a_2 + 2(a_3 + a_4 \dots + a_{n-1})}{2(n-1)};$$

and it is also easily seen that to eliminate as much as possible the influences of the resistance of the air and (let us at once add by anticipation of what ought to be reserved for a subsequent paragraph) of the friction in the pivots of the balance, it is expedient to let  $n$  be an *odd* number. Theoretically this method is, of course, not confined to small  $\Delta$ 's, and it is easy to conceive a balance in which the limb is so graduated that it gives directly the weight of an object placed in the right pan; this is the principle of the *Tangent Balance*, a class of instruments which used to be very generally employed for the weighing of letters, parcels, &c., but is now almost entirely superseded by the spring balance.

After having thus given a general theory of the *ideal*, let us now pass to the *actual* instrument. But in doing so we must confine ourselves mainly to the consideration of that particular class of instruments called precision balances, which are used in chemical assaying, for the adjustment of standard weights, and for other exact gravimetric work.

The *Precision Balance* being, as already said, quite identical in principle with the ordinary "pair of scales," there is no sharp line of demarcation between it and what is usually called "a common balance," and it is exactly

impossible to name the inventor of the more perfect form of the instrument. But taking the precision balance in what is now considered its most perfected form, we may safely say that all which distinguishes it from the common balance proper is, in the main, the invention of the late Mr Robinson of London. In Robinson's, as in most modern precision balances, the beam consists of a perforated flat rhombus or isosceles triangle, made in one piece out of gun-metal or hard-hammered brass. The substitution for either of those materials of *hard steel* would greatly increase the relative inflexibility of the beam, but, unfortunately, steel is given to rusting, and, besides, is apt to become magnetic, and has therefore been almost entirely abandoned. The perforations in the beam are an important feature, as they considerably diminish its weight (as compared with what that would be if the perforations were filled up) without to any great extent reducing its relative solidity. In fact, the loss of carrying power which a solid rhombus suffers in consequence of the middle portions being cut out, is so slight that a very insignificant increase in the size of the minor diagonal is sufficient to compensate for it. Why a balance beam should be made as light as possible is easily seen; the object (and it is as well here to say at once, the *only* object) is to diminish the influence of the unavoidable imperfections of the central pivot. To reduce these imperfections to a minimum, the beam in all modern balances is supported on a polished horizontal plane of *agate* or *hard steel* fixed to the stand, by means of a perfectly straight "*knife-edge*," ground to a prism, of hard steel or agate, which is firmly connected with the beam, so that the edge coincides with the intended axis of rotation. In the best instruments the bearing plane is continuous, and the edge rests on it along its entire length; in less expensive instruments the bearing consists of two separate parts, of which the one supports the front end, the other the hind end of the edge. Every complete balance is provided with an "arrestment," one of the objects of which is, as the name indicates, to enable one to arrest the beam, and, if desired, to bring it back to its normal position; but the most important function of it is to secure to *every point of the central edge* a perfectly fixed position on its bearing. So far all modern precision balances agree; but the way in which the *point-pivots* A and B of our fictitious machine are sought to be realised varies very much in different instruments. In Robinson's, and in the best modern balances, the beam is provided at its two extremities with two knife-edges similar to the central one (except that they are turned upwards), which, in intention at least, are parallel to, and in the same plane as, the central edge; on each knife-edge rests a plane agate or steel bearing, with which is firmly connected a bent wire or stirrup, provided at its lower end with a circular hook, the plane of which stands perpendicular to the corresponding knife-edge; and from this hook the pan is suspended by means of a second hook crossing the first, matters being arranged so that, supposing both end-bearings to be in their proper places and to lie horizontally, the working points A' and B' of the two hook-and-eye arrangements are vertically below the intended point-pivots A and B on the edges. In this construction it is an important function of the arrestment to assign to each of the two terminal bearings a *perfectly constant* position on its knife-

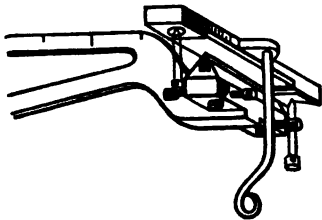

FIG. 3.—Oertling's Balance. End of Beam.

which the former is taken from an excellent instrument constructed by L. Oertling of London, and the latter from an equally good balance, represented in fig. 5, made by Messrs Becker & Co., of New York) shows better than any verbal explanation. But what cannot be seen from these sketches is that the range of the arrestment is regulated, and its catching contrivances are placed, so that when the arrestment is at its highest place, the central edge is just barely lifted from its bearing, and the terminal bearings are similarly lifted from their respective knife-edges, FIG. 4.—Becker's Balance. End of Beam.

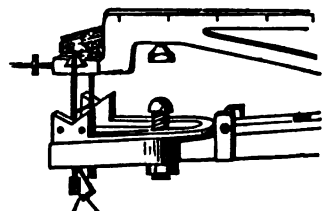

FIG. 4.—Becker's Balance. End of Beam.

is now at rest in its normal position. In other balances, as, for instance, in the justly celebrated instruments of Mr Staudinger of Giessen, Robinson's plane

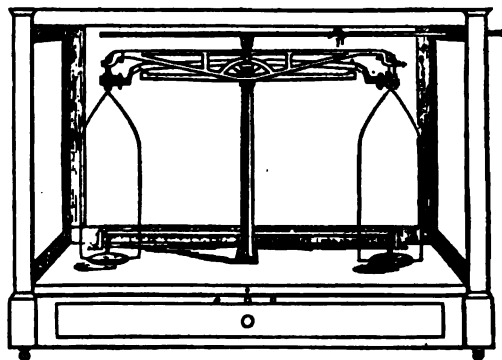

FIG. 5.—Becker's Balance.

terminal bearings are replaced by roof-shaped ones (fig. 6), so that their form alone suffices to secure to them a fixed position on their knife-edges. Another construction (which offers the great advantage of being easy of execution and facilitating the adjustment of the instrument) is to give to the terminal edges the form of circular rings, the planes of which stand parallel to the central edge, and from which the pans are suspended directly by sharp hooks, so that the points A' and B' coincide with A and B respectively. In either case the terminal bearings are independent of the arrestment, which must consequently be provided with some extra arrangement, by means of which the beam, when the central edge is lifted from its support, is steadied and held fast in its normal position. In second and third class instruments even the central edge is made independent of the arrestment, by letting it work in a semi-cylindrical or, what is better, a roof-shaped bearing, which, by its form, assigns to it (in intention at least) a definite position.



FIG. 6.

In order now to develop a complete theory of the precision balance, let us first imagine an instrument, which, for distinctness, we will assume to be constructed on Robinson's model, the knife-edges and bearings, &c., being exactly and absolutely what they are meant to be, except that the terminal edges, while still parallel to the axis of rotation, are slightly shifted out of their proper places. Supposing such a balance were charged with  $P' = p' + p'$  from the left, and  $P'' = p'' + p''$  from the right knife-edge,—and it is clear that in this case also the charges may be assumed to be concentrated,—P' in a certain fixed point A on the

left, and  $P''$  in a certain fixed point B on the right edge, and, consequently, the static condition of the balance is the same as if the weights  $W, P, P''$  were all concentrated in one fixed point  $C_0$  (fig. 7), the position of which, in regard to the beam, is independent of the extent to which the latter may have turned, and independent of the direction of gravity. It is also easily seen that in a given

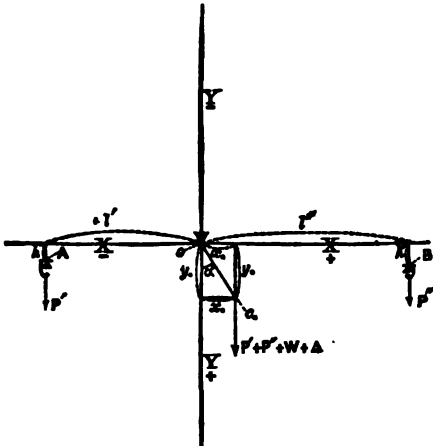

FIG. 7.—Diagram illustrating theory of Precision Balance.

beam the position of  $C_0$  will depend only on  $P'$  and  $P''$ , and supposing  $P'$  to remain constant it will change its position whenever  $P''$  changes its value. The point  $C_0$  will in general lie outside of the axis of rotation, and consequently there will in general be only two positions of the beam in which it can remain at rest, namely, first, that position in which  $C_0$  lies vertically above, and, secondly, that position in which it lies vertically below the axis of rotation. Only one of these two positions can possibly lie within the angle of free play which the beam has at its disposal. The second of the two positions, if it is within this angle, can easily be found experimentally, because it is the position of stable equilibrium, which the beam, when left to itself in any but the first position, will always by itself tend to assume. The first position, viz., that of unstable equilibrium, is practically beyond the reach of experimental determination. Hence the points A, B, and S must be situated so that, at least whenever  $P' = P''$  exactly or very nearly, the beam has a definite position of stable equilibrium, and that this position is within the angle of free play. To formulate these conditions mathematically, assume a system of rectangular co-ordinates, X, Y, Z, to be connected with the beam, so that the axis of the Z coincides with the central edge and the origin with the projection O of the centre of gravity on that edge, while the Y-axis passes through the centre of gravity. Let the values of the co-ordinates of the points A, B, S,  $C_0$  (imagined to be situated as indicated by the figure) be as follows:—

Point	A	B	S	$C_0$
$x =$	$-l'$	$+l''$	0	$x_0$
$y =$	$k'$	$k''$	$a$	$y_0$

(The  $s$ 's are evidently of no practical consequence.) To find  $x_0$  and  $y_0$  we need only again apply the reasoning which helped us in the case of the similar problem regarding the ideal instrument. Assuming, then, first, gravity to act parallel to Y, we have  $(P' + P'' + W) x_0 = P'l' - P''l''$ . Assuming, secondly, gravity to act parallel to X, we have  $(P' + P'' + W) y_0 = P'k' + P''k'' + W a$ ,  $\therefore$  for the distance of the common centre of gravity  $C_0$  of the system

from the axis of rotation,  $r = \sqrt{x_0^2 + y_0^2}$ , and for the angle  $\alpha$  through which the needle, supposing it to start from the zero-point, must turn to reach its position of stable equilibrium—

$$\tan \alpha = \frac{x_0}{y_0} = \frac{P'l' - P''l''}{W a + P'k' + P''k''} \dots \dots (3)$$

If, in particular cases, one or more of the points A, B, S should lie above the X-axis, we need only consider the respective ordinates as being in themselves negative, and the equations (as can easily be shown) remain in force. Taking equation 3, together with what was said before, we at once see that if a balance is to be at all available for what it has been made for, and supposing two of the co-ordinates  $k', k''$  to have been chosen at random, the third must be chosen so that, at least whenever  $P'$  exactly or nearly counterpoises  $P''$ ,  $W a + P'k' + P''k'' > 0$ . For if it were = 0, then, in case of  $P'l' = P''l''$ , the balance would have no definite position of equilibrium, and if it were negative,  $y_0$  would be negative, and the position of stable equilibrium would lie outside the angle of free play. Obviously, the best thing the maker can do is to adjust the balance that  $k' = k'' = 0$  and  $l' = l''$ , because then the customary method of weighing (see above) assumes its greatest simplicity, and, especially, the factor with which the deviation of the needle has to be multiplied to convert it into the corresponding excess of weight present on the respective pan assumes its highest degree of relative constancy. We speak of a degree of constancy because this factor can never be absolutely constant, for the simple reason that no beam is absolutely inflexible, and consequently  $k'$  as well as  $k''$  is a function of  $P'$ , and  $P''$  of the form  $k = k_0 + \gamma P$ , where  $\gamma$  has a very obvious meaning. What is actually done in the adjusting of the best instruments is to place the terminal edges that, for a certain medium value of  $P' + P''$ ,  $k' + k'' = 0$ , so that the sensibility of the balance is about the same when the pans are empty as when they are charged with the largest weights they are intended to carry. The condition  $l' = l''$  also cannot be fulfilled absolutely in practice, but mechanics nowadays have no difficulty in reducing the difference  $\frac{l'}{l''} - 1$  to less than  $\pm \frac{1}{100000}$ , and even a greater value would create no serious inconvenience. We shall therefore now assume our balance to be exactly equal-armed; and, substituting for  $k' + k''$  the symbol  $2k$ , and understanding it to be that (small) value which corresponds to the charge, substitute for equation 3 the simpler expression

$$\tan \alpha = \frac{\Delta l}{W a + 2Pk} \dots \dots (4)$$

which, on the understanding that  $P'' = P + \Delta$ , and that  $\Delta$  is a very small weight, gives the tangent-value corresponding to  $P$  and  $\Delta$ . Sometimes it is convenient to look upon the pans (weighing  $p_0$  each) as forming part and parcel of the beam; the equation then assumes the form—

$$\tan \alpha = \frac{\Delta l}{W'l + 2pk} \dots \dots (5)$$

where  $p = P - p_0$ .

In a precision balance the sensibility, i.e., the tangent-value of the deviation produced by  $\Delta = 1$ , which is

$$\frac{\tan \alpha}{\Delta} = \alpha'' = \frac{l}{W'l + 2pk} \dots \dots (6)$$

must have a pretty considerable value, and at the same time ought to be as nearly as possible independent of the charge. Hence what the equation (4) indicates with reference to a balance to be constructed is, that, so far as these two qualities are concerned, we may choose the weight of the beam as we like; and in regard to the sensibility which the instrument is meant to have when charged to a certain

extent, we have even the free choice of the arm-length, because, whatever  $l$  or  $W$  be, if only the centre of gravity of the empty beam is brought to the proper distance from the central edge, we can give to the sensibility any value we please. What is actually done is so to construct the beam that its centre of gravity lies decidedly lower than one would ever care to have it, and then to connect with the beam a small movable weight (called the "bob") in such a manner that it can be shifted up and down along a wire, the axis of which coincides with the  $Y$ -axis, and thus the value  $e_0$  of the distance of the centre of gravity of the beam from the central edge be caused to assume any value, from a certain maximum down to nothing, and even a little beyond nothing. As to the relative independence of the sensibility of the charge, equation 5 shows that a given balance will possess this quality in the higher a degree the less the distance  $h$  of the central edge is from the plane of the two terminal ones, and, supposing  $h$  to be constant (i.e., the adjustment to be finished), the less the initial sensibility  $\alpha_0$  exhibited by the empty instrument. Passing from one balance to the other, but supposing  $h$  and  $\alpha_0$  to remain constant, we readily see that the sensibility is the more nearly independent of the charge  $p$  in the pans, the greater the arm-length  $l$  is. From what has been said above, it would appear that by means of a balance provided with a gravity-bob, we could attain any degree of precision we liked, but evidently this is not possible practically, because in the actual instrument neither the knife-edges and their bearings nor the arrestment are what we have hitherto supposed them to be; and, consequently, both  $l$  and  $l'$  as well as  $h$ , instead of being constants, are *variable quantities*. Obviously, the non-constancy of the ratio  $l : l'$  is the most important point, and to this point we shall therefore confine our attention. Let us imagine that the imaginary balance hitherto considered has been charged equally on both sides (with  $P = p_0 + p$ ), so that its normal position is its position of rest, and then assume, first, that the *middle edge* (which hitherto has been an absolutely rigid line) is now a narrow and slightly, but irregularly, curved rough surface. The effect will be, that, supposing the balance to be repeatedly arrested and made to vibrate, the axis of rotation, instead of being constant, will shift irregularly between  $x = +\lambda$  and  $x = -\lambda$  where  $\lambda$  means a small length. But this comes to the same as if the central pivot were absolutely perfect, but had the common centre of gravity  $C_0$  instead of being fixed at  $x = 0$ , oscillating between  $x = \pm \lambda$ . In other words, the balance may possibly come to rest at any position within a certain angle  $\pm \beta$ , which, as an angle of deviation, corresponds to the overweight

$$e_0 = \{2(p_0 + p) + W\} \frac{\lambda}{l}.$$

Assume now, secondly, that, say, the right terminal edge was slightly turned so as no longer to be parallel to the middle edge. This *is itself* would not matter much, because although it might produce a change in the length of the right arm, this change would be permanent, and the arm-length again be constant, provided the hook-and-eye arrangement for the suspension of the pan, and the arrestment, were ideally perfect. But, practically, they are *not*, and, moreover, the knife-edge and its bearing are not what theory supposes them to be; and the effect is the same as if the virtual point of application  $A$  of the charge  $p_0 + p$ , instead of being at the constant distance  $l$  from the centre, oscillated irregularly between  $l + \lambda'$  and  $l - \lambda'$ , where  $\lambda'$  has a similar meaning to that of  $\lambda_0$ . The joint effect of the imperfections of the three pivots is that the indications of the balance, instead of being constant, are variable within  $\pm \epsilon$ , where  $\epsilon$  means a small weight determined approximately by the equation—

$$\epsilon = \frac{1}{l} \{ [2(p_0 + p) + W] \lambda_0 + 2(p_0 + p) \lambda \} \quad (7).$$

Hence, in a balance to be constructed for a given purpose,  $l$  must be made long enough to make sure of its compensating the effects of the  $\lambda$ 's, which, for a given set of knife-edges and a given degree of absolute exactitude in their adjustment, may be assumed to have constant values. Evidently in a given balance  $\epsilon$  has nothing to do with the sensibility and consequently it would be useless to increase the sensibility beyond what is required to make the angle  $\beta$ , corresponding to  $\epsilon$  (i.e. that angle within which the balance is, so to speak, in indifferent equilibrium) *conveniently visible*. To go further would, in general, be a mistake, because the greater the sensibility the more markedly it varies with the charge, the less is the maximum overweight which can be determined by the method of vibration, and, last not least, the more slowly the balance will vibrate, because the time of vibration  $t$  is governed by the equation—

$$t = \sqrt{\frac{kW + 2(p_0 + p)}{Wg_0 + 2h(p_0 + p)}} \cdot \frac{l}{\sqrt{R_0}},$$

where  $k$  is a constant which depends on the shape of the beam, and for the ordinary perforated rhombus is about  $-\frac{1}{3}$ , while  $R_0$  stands for the length of the pendulum beating seconds at the place. Introducing the sensibility—

$$\alpha = \frac{l}{Wg_0 + 2h(p_0 + p)}, \text{ we have } t = c \sqrt{\alpha}, \text{ where } c \text{ is a constant.}$$

4. *Compound Lever Balances.*—Of these numerous inventions—in all of which a high degree of practical convenience is obtained at the expense of precision—we must content ourselves with noticing two which, on account of their extensive use, cannot be passed over. We here allude, in the first place, to that particular kind of equal-armed lever balances, in which the pans are situated above the beam, and which are known as "*Roberval's balances*," and secondly, to those peculiar complex *steel-yards* which are used for the weighing of heavy loads by means of comparatively small weights.

In *Roberval's balance* (fig. 8), the beam consists of a parallelogram, in which each of the four corners  $A, B, A', B'$  is a joint, and which by means of two joints situated in the centres of the two longer sides  $AB$  and  $A'B'$  is suspended from a vertical rod so that the two shorter sides  $AA'$  and  $BB'$  under all circumstances stand vertical. With these two sides the pans are rigidly connected; and the main feature in the machine is, that wherever the charge in the pan may lie, i.e., whatever may be the virtual point of application of the whole charge  $P$  in regard to the vertical side of the beam, its statical effect is the same as if  $P$  was concentrated in a point  $D$  in the axis of the rod  $AA'$  or  $BB'$ . That this really is so is easily proved. Imagine the particle weighing  $P$  units to be rigidly connected with, say,  $AA'$ , but situated to the left of that line, and, whatever may be its distance from  $AA'$ , when the beam descends through a certain angle, the vertical projection of the path described by the point  $D$ , i.e., its fall  $h$ , has the same value whatever its distance from  $AA'$ . Hence the work done, say, against an elastic string tending to hold the beam in its place, invariably is  $= Ph$  as it would be if  $D$  was situated in  $AA'$ .

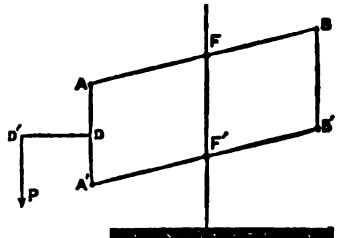

FIG. 8.—Roberval's Balance.

The ordinary *Decimal Balance* is a combination of levers illustrated by fig. 9. *a, c, b, d, e, g, h, f,* are all joints or pivots; *a* and *h* rest on the fixed framework of the machine, and consequently indirectly on the ground; *c* rests on the lever *ab*. In the actual machine *cd* supports the "bridge," which accommodates the load, while at *f* is suspended a pan for the weight. The pan is adjusted

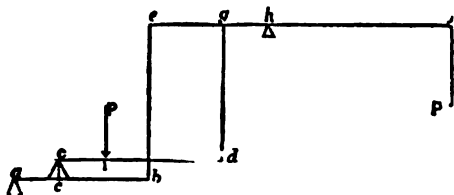

FIG. 9.—Decimal Balance.

that it balances the bridge. Suppose the load *P* to be placed so that its centre of gravity is at *i*, and a portion *P<sub>1</sub>* of *P* will press on the knife-edge at *c*, the rest *P<sub>2</sub>* will pull at *d* and, with the same force, at *g*. Now,  $P_1 = P \cdot \frac{ic}{cb}$  equivalent to  $\frac{ac}{ab} P$ , pulling at *b* or *e*, equivalent to  $P \cdot \frac{ac}{ab} \cdot \frac{cd}{cd} \cdot \frac{ah}{ah}$  pulling at *g*. The dimensions are so chosen that  $\frac{ac}{ab} = \frac{ah}{cd}$ , hence the effect of *P<sub>1</sub>* at *g* is equivalent to a weight  $P \cdot \frac{ic}{cd}$ . The other portion of *P* viz., *P<sub>2</sub>* pulls at *d*, and consequently also at *g*, with a force  $P \cdot \frac{id}{cd}$ . Hence the effect of the total load is equivalent to  $P \cdot \left( \frac{ic}{cd} + \frac{id}{cd} \right) = P$  units suspended at *g* and if, for instance,  $gh = \frac{1}{10} hf$ , one pound in the pan will counterpoise ten pounds at any point of the bridge.

5. *Torsion Balances*.—Of the several instruments bearing this name, the majority are no balances at all, but machines for measuring horizontal forces (electric, magnetic, &c.), by the extent to which they are able to distort an elastic wire vertically suspended and fixed at its upper end. In the torsion balances proper the wire is stretched out horizontally, and supports a beam so fixed to it that the wire passes through its centre of gravity. Hence the elasticity of the wire here plays the same part as the weight of the beam does in the common balance. An instrument of this sort was invented by Ritchie for the measurement of very small weights, and for this purpose it may offer certain advantages; but, clearly, if it were ever to be used for measuring larger weights, the beam would have to be supported by knife-edges and bearings, and in regard to such application therefore (i.e., as a means for serious gravimetric work), it has no *raison d'être*. See ELECTRICITY and MAGNETISM.

6. For *Hydrostatic weighing machines* see the ARTHYDROMETER. (W. D.)

**BALANCE OF POWER.** The theory of the Balance of Power may be said to have exercised a preponderating influence over the policy of European statesmen for more than two hundred years, that is, from the Treaty of Westphalia until the middle of the present century; and to have been the principal element in the political combinations, negotiations, and wars which marked that long and eventful period of modern history. It deserves, therefore, the attentive consideration of the historical student, and, indeed, the motive cause of many of the greatest occurrences would be unintelligible without a due estimate of its effects. Even down to our own times

it has not been without an important influence; for the Crimean War of 1854 was undertaken by England and France for no other object than to maintain the balance of power in Eastern Europe, and to prevent the aggrandisement of Russia by the dismemberment of the Ottoman empire and the conquest of Constantinople. Nevertheless there is, perhaps, no principle of political science, long and universally accepted by the wisest statesmen, on which modern opinion has, within the last twenty years, undergone a greater change, and this change of opinion is not merely speculative, it has regulated and controlled the policy of the most powerful states, and of none more than of Great Britain, in her dealings with the continent of Europe. At the date of the publication of the last edition of this work, the theory of the balance of power was believed to be so firmly established, both by reason and experience, that it was laid down, in the forcible words of Earl Grey, that "the poorest peasant in England is interested in the balance of power, and that this country ought to interfere whenever that balance appeared to be really in danger." At the present time no English statesman would lay down that proposition categorically; and probably no European statesman would be prepared to act upon it. In proportion as the theory of the balance of power has lost much of its former authority, the doctrine of non-intervention has gained strength and influence, and this has been accepted at the present day both by Whig and Tory ministers, so that no strong difference of opinion can at the present time be said to exist in the British nation on the subject. Within the last fifteen years political changes of extraordinary magnitude have been brought about in Europe by force of arms and by revolutions. In former times such changes would certainly have led to a general war, on the principle that it was essential to maintain the relative strength and independence of states, and to support the fabric of European policy. But, under the policy of non-intervention, the effects of these contests have been confined to the states which were directly engaged in them; and the other powers of Europe have maintained a cautious neutrality, which has probably not lessened their own strength, and which has saved the world from a general conflagration.

The theory of the balance of power rested on several assumptions. It was held, more especially from the time of Grotius, in the early part of the 17th century, that the states of Europe formed one grand community or federal league, of which the fundamental principle and condition was the preservation of the balance of power; that by this balance (in the words of Vattel) was to be understood such a disposition of things, as that no one potentate or state shall be able absolutely to predominate and prescribe laws to the others; that all were equally interested in maintaining this common settlement, and that it was the interest, the right, and the duty of every power to interfere, even by force of arms, when any of the conditions of this settlement were infringed or assailed by any other member of the community. The principle can hardly be more tersely expressed than in the words of Polybius (lib. 1. cap. 83): "Neque enim ejusmodi principia contemnere oportet, neque tanta cuiquam astruenda est potentia, ut cum eo postea de tuo quamvis manifesto jure disceptare ex æquo non queas." Or, to borrow the language of Fénelon in his *Instructions*, drawn up by him for the guidance of the Duc de Bourgogne, "This attention to maintain a sort of equality and equipoise between neighbouring nations is the security of the general tranquillity. In this respect all neighbouring nations, trading with each other, form one great body and a sort of community. Thus, Christendom is a kind of universal republic, which has its interests, its fears, and its precautions to be taken. All the members

of this great body owe it to one another for the common good, and owe it to themselves for the security of their country, to prevent the progress of any other members who should seek to overthrow this balance, which would turn to the certain ruin of all the other members of the same body. Whatever changes or affects this general system of Europe is too dangerous, and draws after it infinite mischiefs." Whatever may be the value of these philanthropic principles, history reminds us that when they were most loudly professed they were most frequently violated, and that no cause of war seems to have been so frequent or so fatal as the spurious pretext of restoring peace and defending the general tranquillity of the world. Thus, it was to balance the power of the house of Austria that Cardinal Richelieu flung France into the quarrels of Germany in the Thirty Years' War, and even lent her aid to the Protestant cause. It was to balance the encroaching and aggressive power of Louis XIV. that numerous combinations were formed between England, Austria, and Holland, which, after nearly half a century of almost uninterrupted contests and bloodshed, ended in the peace of Utrecht. The pretext of Frederick II., when he was meditating some act of rapine, generally was that he believed some hostile combination had been formed against him, which it was wise to anticipate. In short, no cause of war has been more frequently alleged and acted upon, than that a proper consideration for the balance of power rendered it necessary to take forcible measures to avert some remote or hypothetical danger.

It is obviously a maxim, not only of policy but of common sense and human nature, that the weak should combine to protect themselves against the strong, and that when the independence of minor states is threatened by the ambition or the overwhelming superiority of a power aiming at universal empire, they will do wisely to unite for the purposes of self-defence and resistance. Frederick II. himself says, in his *Anti-Machiavel*, where he laid down precepts which he did not practise, "When the excessive aggrandisement of one power threatens to overwhelm all others, it is the part of wisdom to oppose barriers to its encroachments, whilst there is yet time to stay the torrent. The clouds are seen to gather, the lightning announces a coming storm, and the sovereign who is unable to contend against the tempest will, if he is wise, unite himself with all those who are menaced by the same common danger. Had the kings of Egypt, Syria, and Macedonia confederated together against the Roman power, they would not have fallen under its oppressive yoke; an alliance prudently contracted, and a war carried on with energy, would have saved the ancient world from universal despotism." So too, Hume, in his celebrated *Essay on the Balance of Power*, endeavours to show that the ancients were familiar with the principle both as statesmen and historians, and, for example, he avers that whoever will read Demosthenes's oration for the Megalopolitans, will see the utmost refinements on this principle that ever entered into the head of a Venetian or European speculatist.

But with great respect to these illustrious authorities, they appear to have discussed, under the name of the balance of power, a principle which might more fitly be termed a theory of warlike alliances. The object of the balance of power, rightly understood, is not to carry on war with success, but to avoid war altogether, by establishing a common interest and obligation in the maintenance of the conditions of peace. When war is declared, public law is suspended, and each state must be guided by what it conceives to be its own interest and duty. If the theory of the balance of power has any value at all, it is not in the hour of violence and bloodshed, when the fate of nations may be decided on a field of battle, but rather in

those negotiations which must eventually terminate the contest, which commonly bring together for that purpose the representatives of all the belligerents, and which are designed to provide against the recurrence of these calamities.

The ablest and most eloquent champion of the system of equipoise in the present century was the Chevalier von Gentz, who published his *Fragments upon the Balance of Power in Europe* in 1806, under the influence of the catastrophe which had subjugated the Continent, and who subsequently took an active part at the Congress of Vienna in the attempts to constitute a new system of European policy. Gentz defines the balance of power as "a constitution subsisting between neighbouring states more or less connected with one another, by virtue of which no one among them can injure the independence or essential rights of another, without meeting with effectual resistance on some side, and consequently exposing itself to danger." And he rests this constitution on four propositions:—(1.) That no state must ever become so powerful as to coerce all the rest; (2.) That every state which infringes the conditions is liable to be coerced by the others; (3.) That the fear of coercion should keep all within the bounds of moderation; and (4.) That a state having attained a degree of power to defy the union should be treated as a common enemy. He argues that by a strict adherence to these principles wars would be averted, excessive power restrained, and the independent existence of the humblest members of the confederacy secured. But, for the reasons we have previously assigned, it is a fallacy to suppose that even the civilised states of Europe have ever naturally formed a confederacy, or that their relations are governed by common rules of action, recognised alike by all of them. That theory supplies a very insecure basis for the balance of power and the maintenance of peace. The law of nations, not being imposed or sanctioned by any supreme and sovereign authority, is, in fact, reducible to the general laws of morality, which ought to regulate the dealings of mankind, except when it has been expressed and established in the form of a contract, binding on all the parties to that obligation. To determine the true character and limits of the balance of power, we must have recourse, not to vague general principles, but to positive law, framed in the shape of international contracts, which are termed treaties, and which have been sanctioned at different epochs of modern history by a congress of states. This historical treatment of the subject leads us to more tangible and solid ground; and it will be seen that on these occasions more especially attempts have been made to establish a balance of power in Europe upon the basis of general treaties; and that these attempts have been rewarded by considerable, though not by permanent, success in the 17th, 18th, and 19th centuries.

The first idea of a general congress, to put an end to the horrors of the Thirty Years' War, and to adjust the conflicting claims of rival creeds and hostile princes, appears to have originated with the emperor of Germany in 1640. The attempt to restore peace by the authority of the Germanic Diet had failed. It became necessary to have recourse to mediating powers, and after a protracted preliminary negotiation, the Congress of Münster or Westphalia opened on the 11th July 1643,—the Catholic and Protestant belligerents being represented on the one hand, and the mediating powers, France, Sweden, Venice, and the Pope, on the other. We do not propose in this place to follow the train of these complicated negotiations. It is enough for our present purpose to remark that the great treaty which resulted from them, and was signed on the 24th October 1648, became the basis of the public law of Europe, and the first official recognition of the existence of a European balance of power. The conditions established



in Germany left the Catholic, the Lutheran, and the Reformed Churches in possession of their respective independence, whilst they relieved the minor princes from their strict dependence on the empire; but, above all, they conferred on France and Sweden, as mediating powers, the right of intervention for the purpose of upholding the provisions of the treaty. In other words, the balance which had been established between the states of Central Europe was regulated by external weights, which could be brought to bear upon it. The result of this combination, due mainly to Cardinal Mazarin, was certainly injurious to the unity and independence of Germany, and it tended to aid the aggressive and dictatorial power of Louis XIV. Nevertheless, the fundamental principles of the Treaty of Westphalia were recognised and renewed as the conditions of the general peace of Europe down to the French Revolution; they were not wholly absent from the minds of the negotiators at Vienna in 1815; and they only received their death-blow from the hand of the Prussian Government in 1866 and 1870. Whatever might be the merits of the Treaty of Westphalia, it had not that of securing to Europe an unbroken or durable peace; and even the territorial relations of France and Germany were altered within thirty years of that time by the conquest of Franche Comté and Alsace. But the wars of Louis XIV. were not general wars, until he engaged in the fatal attempt to place his grandson on the throne of Spain, and to unite the two crowns in the house of Bourbon. Efforts had been made, in view of the approaching extinction of the Spanish branch of the house of Austria, to preserve the balance of power by a timely partition of the vast dominions of the Spanish empire—a remarkable example of an attempt to prevent a formidable catastrophe by an equitable arrangement. But it may be doubted whether any arrangement in which so little account was taken of the wishes and traditions of nations could possibly have succeeded; and it unquestionably failed, because Louis XIV. did not hesitate to repudiate the treaties he had signed, and to avail himself of the last will and testament of Charles II., which had been extorted from the Spanish court by his intrigues. That event raised again the whole question of the balance of power in Europe. It was received as a doctrine of political faith that the union of the French and Spanish crowns in one family must be fatal to the independence of all other states; that it would replace the Stuarts upon the throne of England, and establish the ascendancy of France and the Catholic party over Europe. It was therefore resisted by a coalition, of which England, Austria, and Holland were the principal members. France was at length reduced to the lowest point of humiliation, and in 1709 peace might have been obtained on every point but one. Louis refused to turn his arms against his own grandson, and the war continued till 1715. Philip V. retained the Spanish crown, and the relations of all the European states were once more adjusted with legal nicety at Utrecht. Great pains were taken to provide, by a system of renunciations, against the possibility of the union of the crowns of France and Spain on the same head, because it was held that such a contingency would be fatal to the balance of power in Europe. But these precautions did not prevent the conclusion, at a later period, of the family compact between the two branches of the house of Bourbon, which was regarded as a lasting danger to other countries, and was opposed by the whole strength of Britain and the genius of Chatham. The peace of Utrecht was denounced by Parliament and detested by the nation as an inglorious termination of a glorious war, and its authors were consigned to obloquy and exile; but it secured the peace of Europe for thirty years; it reduced the power of France; and had it not been for the German dominions of the house

of Hanover, it might have been still longer before England was drawn into another war.

Hitherto the political system of Europe had comprised little more than the states of France, Austria, Spain, Sweden, and Holland, with the occasional intervention of Great Britain, more for the defence of the interests of others than of her own. But the 18th century witnessed a total change in the politics of the world. A new empire, Russia, arose in the north, under the genius of Peter and of Catherine; the ambition and military skill of Frederick II. raised Prussia from a secondary member of the German empire to a powerful and independent kingdom; the colonial empires of Spain, France, and Britain had extended their territorial interests to the continents of Asia and America, and to the eastern and the western seas, inasmuch that wars, begun in Europe, soon raged on the banks of the Ganges and the St. Lawrence; and the declaration of independence of the United States of America called into being a new and powerful people of the future. The partition of Poland, which was commenced in 1772, marked a new era of aggressive revolutionary policy; it was a gross invasion of the principle of the balance of power, effected by three powers, jealous of their respective strength, but indifferent to the rights of an independent nation and to the opinion of Europe.<sup>1</sup> That lawless act was the prelude to more violent attacks on the sovereignty and nationality of many countries, for before the century closed the French Revolution, and the wars that followed it, crushed to atoms the ancient fabric of Europe. Whilst events of this magnitude were occurring in the world, it is obvious that the theory of the balance of power was entirely displaced and dislocated. New elements were at work over a far wider area; new sources of power and influence were opened of far more importance than those territorial and dynastic questions which occupied the statesmen of Münster and of Utrecht; ancient land-marks were swept away; minor states were annihilated; and the temporary domination of Napoleon over a great portion of the continent of Europe seemed to have overthrown the balance of power for ever. In those dark and evil days public writers like Gents and Mackintosh still maintained the principle that peace could only be restored by a due recognition of the rights and independence of every nation, and England adhered inflexibly to the policy of combining the scattered elements of Europe against the common enemy. Half a dozen times over these coalitions failed; but they succeeded at last, and this country had the glory of playing no inconsiderable part in the restoration of the liberties of all other nations against foreign aggression. Great as were the cost and the burden of that tremendous war, we still hold that the prodigious power of France and the boundless ambition of Napoleon left us no honourable alternative but to pursue it; and, as Mr Fox himself discovered when he conducted the negotiations of 1806, it was impossible to conclude peace with France without basely surrendering the whole interests of Europe to universal oppression, and without exposing this country to be at least the victim of a power which had devoured all the rest. The principle of the balance of power, in the sense of mutual defence, was never asserted with greater energy than it was by this country in that struggle, and we do not regret it. "As long," says Bacon, "as men are men, and as long as reason is reason, a just fear will be a just cause of a preventive war; but

<sup>1</sup> It deserves to be noticed that down to the partition of Poland, no state, however small, had been extinguished, annihilated, and "annexed" in the continuous wars of the two previous centuries—down to the republics of Geneva and San Marino all retained their national existence. The wars of the French Revolution, and still more the wars of our own times, have swept a multitude of the minor states and dynasties from the map of Europe, and incorporated them in larger empires.

especially if it be part of the case that there be a nation that is manifestly detected to aspire to new conquests, then other states assuredly cannot be justly accused for not paying for the first blow, or for not adopting Polyphemus's courtesy, to be the last that shall be eaten up."—(*Speech concerning a War with Spain.*)

Upon the fall of Napoleon in 1814 it became the common interest, and the universal desire, of all the sovereigns and nations of Europe to restore peace upon a settled basis, to re-establish the authority of public law, to reinstate the rightful owners in the possessions and dominions they had been forcibly deprived of, to reduce the military establishments which weighed so heavily on the finances and on the population of Europe, and to create anew a balance of power between the states of Europe, by which the greatest of them might be restrained and the least of them protected. A secret article had been annexed to the Treaty of Paris, declaring that "the allied powers had agreed among themselves on the bases which were to be given to the future system of equilibrium;" though what the nature of that agreement and of those bases was, has never been made clearly apparent. But the matter was unquestionably referred to the congress then about to open at Vienna, where the most powerful sovereigns and the most distinguished ministers of all the European states met for the first time in council. That congress was certainly the most complete, and in its action the most important, assemblage of independent political powers and their representatives which ever took place in the world. Its decisions were not all of them just, or wise, or disinterested. The broad general principles of pacification which had been laid down were more than once traversed and thwarted by particular interests and ambitions. The theory of the rights of legitimate sovereigns over their subjects was carried to an extravagant point, pregnant with danger for the future. Genoa was transferred to Sardinia, Venice to Austria, Norway to Sweden, Poland to Russia, part of Saxony to Prussia, and the sacred hopes and pledges of freedom which had animated the nations in the contest were forgotten by the leading courts of Europe in the division of the spoil. But in spite of these shortcomings and abuses, we cannot concur with writers who, like Hardenberg, denounce the Congress of Vienna as an auction of nations and an orgy of kings. It was said that every one withdrew from the Congress of Vienna disappointed, no one having obtained as much as he expected; but if so, that would suggest the inference that the general interest of Europe prevailed over the pretensions of each particular state. From the point of view we are now considering, which is the restoration of the balance of power, it cannot be denied that the Treaties of Vienna secured forty years of peace to Europe. They stood the brunt of two fresh convulsions in France in 1830 and in 1848, and their main provisions, though modified with respect to the Low Countries in 1832, and abrogated in Italy by the campaign of 1859, were not seriously impaired until the dissolution of the Germanic body in 1866, and the Franco-German War of 1870. During the whole of this period the warlike ambition of France, and the disposition of Russia to overawe Central Europe, were successfully held in check. At Vienna itself, and during the congress, the struggle was close and sometimes doubtful. Russia was resolved to retain the whole of Poland, which she occupied with her armies, and Prussia claimed the whole of Saxony as a compensation for her share of the Polish provinces. To counteract this combination of Russia and Prussia, an alliance was signed on the 3d January 1815 between Austria, England, and France, which might have led to hostilities between those powers and their recent allies. Perhaps it was fortunate that the return of Napoleon from Elba

broke up the congress, and reminded all the powers that union and mutual concessions were the first duties of those who had devoted themselves to the cause of law, order, and peace. It was a sign of the wisdom of the congress, and of its respect for sound principles, that although France was the vanquished power and the author of the calamities of Europe, she was treated at Vienna with as much consideration as any other state. Her ambassador, M. de Talleyrand, had his full weight in the congress; and no attempt was made in 1814 to curtail her ancient territorial possessions or to lower her rank in Europe. On the contrary, the just influence of France was recognised as an essential condition of the balance of power.

For the first time, then, by this general act of the Congress of Vienna, the territorial possessions and frontiers of the Continental states were defined in one document, to which all the Governments of Europe were parties; the constitution of the Germanic body was incorporated in the same instrument, and the neutrality and independence of the smallest cities and commonwealths were established and guaranteed. Every state in Europe had therefore an equal right and interest to invoke the authority of the treaty, and to claim the execution of all its conditions. A complete fabric of European polity, such as had never existed before, was thus literally established by mutual contract; and every infraction of it might justly be brought under the consideration of the high contracting parties, or might even have been the ground of a declaration of war. In several instances this controlling power was wisely and beneficially exercised, and more than one burning question was adjusted by the conferences which met from time to time, always on the basis of the treaties of 1815. This certainly was the nearest approach ever made to a practical balance of power: and we owe to it, as we have seen, a long period of mutual confidence, respect for public law, and peace, which contributed enormously to the progress, prosperity, and happiness of the world.

But there are darker shades to the picture. The comprehensive interest which every state was thus held to have acquired in maintaining the general settlement might be held, and was held, to justify a dangerous and mischievous degree of intervention in the internal affairs of every other country, and this right was too often exercised in a manner injurious to liberty and independence. The northern powers, not content with the terms of the general alliance and the Treaties of Vienna, proceeded to connect themselves more closely by the mystic ties of the Holy Alliance, which provided that they were to act together on all subjects, and to regard their interests as one and indivisible. The construction they put upon the system recently established in Europe was that it gave the allied powers a right to interfere, not only for the prevention of quarrels, aggressions, and war, but in the internal government of states, for the purpose of preventing changes which they chose to regard as injurious to their own security and eventually to the balance of power. At the congresses and conferences of Troppau, Carlsbad, Aix-la-Chapelle, and Verona, these doctrines were avowed and acted upon to their furthest extent, and under pretence of maintaining and defending the common interests of Europe, the popular movements and constitutional progress of Italy were crushed, a French army entered Spain in 1823 to restore the authority of Ferdinand VII against the Cortes, and even the independence of the South American colonies was represented as a blow to the peace and security of Europe. The British Government had early perceived that the interpretation thus given to the theory of the balance of power, and to what was termed the federal system in Europe, was only another name for an intolerable oppression, and that the right of intervention in the internal affairs of other countries

was claimed and exercised under false and dangerous pretence. The duke of Wellington, who represented this country at the Congress of Verona, under instructions framed by Lord Castlereagh, was the first to declare that England could be no party to such an application of the theory of the alliance, and that this country preferred isolation to any such system of combined policy. That was the germ of the modern doctrine of non-intervention. But as long as the Treaties of Vienna lasted, it was our duty and our right to endeavour to support their authority, and to vindicate the rights established by a compact to which this country was a party. We declined in 1852 to join with Prussia in enforcing the declaration made by the allied powers in 1815, which excluded any member of the family of Bonaparte from the throne of France; but we sought, in conjunction with France, to protest against the annihilation of the kingdom of Poland, the incorporation of Cracow, the admission of non-German provinces into the confederation, and the invasion of Schleswig; and we opposed the annexation of Savoy and Nice to France, but alone and without effect. The compact of Vienna was gradually set aside and violated in the course of years by those who were most interested in maintaining it; and when the Emperor Napoleon III. proposed, in 1863, a new congress for the purpose of revising and re-establishing the balance of power in Europe, under the name of an International Council, England refused to be a party to the negotiation, and rejected the scheme. Lord Russell replied, "There being no supreme authority in such an assembly to enforce the decision of the majority, the congress would probably separate, leaving many of its members on worse terms with each other than they had been before." This was the last attempt made to bring the authority of a congress, representing the collective authority of Europe, to bear on questions affecting the general peace. When this point was reached it was apparent that the whole theory of the confederated system in Europe had become, for a time at least, obsolete; that the treaties and mutual guarantees on which that system rested had lost their power; and that there was no controlling force to resist the ambitious or warlike designs of any state capable of giving effect to them. The Italian campaign of 1859 had considerably altered the condition of Southern Europe, and weakened Austria. Possibly, Prussia, in withholding her assistance at that time from her federal ally, foresaw in the defeat of Austria an event favourable to her own future pretensions. At any rate, for the first time, a war seriously affecting the balance of power was begun and ended by the two principal belligerents alone, and even the price paid by the house of Sardinia for the services of France—the cession of Savoy and Nice—was tacitly acquiesced in by Europe. Twenty years before, it would have been thought impossible that the doctrine of non-intervention should have acquired so great an ascendancy.

But the consequences of this novel state of affairs soon became manifest in the increasing disintegration of Europe. No state could have a greater claim than Denmark to the protection of the principles of the balance of power, for, as late as 1852, all the great powers had pledged themselves by treaty to maintain the integrity of her dominions, the unity of the monarchy, and the order of succession to the crown which was then established. Yet in 1864 the German powers proceeded to what was termed a Federal Execution against her; Holstein, Lauenburg, and, eventually, Schleswig were torn from her by Prussia, Austria acting a subordinate part. England in vain appealed by her diplomacy to the terms of the agreement of 1852, but France and Russia stood aloof, and the greatest injustice the world had witnessed since the partition of Poland was consummated. As every event in political

life is closely connected, Prussia now proceeded to ally herself with the crown of Italy against Austria, and to execute her grand design of the overthrow of the Germanic Confederation and the expulsion of Austria from that body, which had been regarded as the centre of gravity of the European system. As long as that body subsisted, war was impossible between its respective members, and France was incapable of attacking their united forces. The success of Prussia in the campaign of 1866 was rapid and complete, and Austria ceased to form part of the Germanic Confederation. The power of Prussia was further increased by the military conventions, which gave her the absolute command over the armies of the minor German states. This was undoubtedly the severest blow which had yet been inflicted on the balance of power in Europe; and the Emperor Napoleon III., who had recently given vent to his dissatisfaction with the treaties of 1815, now found himself confronted by an enemy infinitely more powerful and dangerous. The results of Sadowa were as fatal to the influence and security of France as if she herself had lost a campaign. The French nation, however, failed to understand the magnitude of the danger, though they were irritated by the approach of it. War was, on more than one occasion, on the point of breaking out; and at length France plunged into it with a recklessness and incapacity only to be equalled by the tremendous calamities that war caused her to endure. Again, no third state was drawn by political considerations into the conflict. The terms of peace were settled between the vanquished and the conquerors without reference to the general interests of other nations; and no attempt has been made to place these arrangements under the sanction of the public law of Europe. Russia took advantage of the agitated condition of Western Europe to abrogate, by her own will and pleasure, an important stipulation of the Treaty of Peace of 1856, and Europe again submitted to this breach of covenant.

The general result is that, at the present time, the military power of the German empire far surpasses that of any other state, and could only be resisted by a general combination of all the rest. The balance of power, as it was understood fifty years ago, and down to a more recent time, has been totally destroyed; no alliances can be said to exist between any of the great powers, but each of them follows a distinct course of policy, free from any engagements to the rest, except on some isolated points; the minor states can appeal to no certain engagement or fixed general principle for protection, except, perhaps, as far as the neutrality of Switzerland and Belgium is concerned; and for the last two centuries there has not been a time at which all confidence in public engagements and common principles of international law has been so grievously shaken. Where the reign of law ends, the reign of force begins, and we trace the inevitable consequence of this dissolution of legal international ties in the enormous augmentation of military establishments, which is the curse and the disgrace of the present age. Every state appears to feel that its security depends on arming the whole virile population, and maintaining in what is called a state of peace all the burdens of a complete armament; indeed, in the most barbarous ages and the most sanguinary wars there were, doubtless, fewer men under arms, and less money was spent in arming them, than at the present day.

We have shown in the preceding observations that we do not retain the faith of our forefathers in the balance of power. - It is impossible to equalise the strength of nations. It is impossible to regulate or control the growth and development of their forces, which depend not on territorial possessions alone, but on their industry, their credit, their natural resources, and their internal institutions. It is

impossible to weigh their relative power and influence in nice or golden scales, nor can we always compel them "parcere subjectis et debellare superbos." But the recognition of certain mutual obligations and principles of public law is the fundamental condition of civilisation itself. Nothing can be more injurious to society than that the states of Europe should exist without alliances, without mutual confidence, without a common system based on the principles of justice and of peace, the weak living in dread of the strong, the strong armed to the teeth against each other. We trust that before another great catastrophe arises from this state of disguised hostility, a truer balance of power may be established by a return to sounder principles; for peace can never be secure unless it is protected by the concurrence of the leading nations of the world, and by their determination to oppose a combined resistance to those who have no object but their own aggrandisement and ambition. (H. R.)

**BALASOR**, a district of British India in the Orissa division, under the Lieutenant-Governor of Bengal, lies between 20° and 21° N. lat., and in 86° and 87° E. long., and is bounded on the N. by the district of Midnapur; on the S. by Cattaek district, from which it is separated by the Baitarani river; on the W. by the tributary states of Keunjhar, Nilgiri, and Morbhanj; and on the E. by the Bay of Bengal. Balasor district forms a strip of alluvial land between the hills and the sea, varying from about 9 to 34 miles in breadth; area, 2066 sq. miles. The hill country rises from the western boundary line. The district naturally divides itself into three well-defined tracts—(1.) The Salt Tract, along the coast; (2.) The Arable Tract, or rice country; and (3.) The Submontane Tract, or jungle lands. The Salt Tract runs the whole way down the coast, and forms a desolate strip a few miles broad. Towards the beach it rises into sandy ridges, from 50 to 80 feet high, sloping inland, and covered with a vegetation of low scrub jungle. Sluggish brackish streams creep along between banks of fetid black mud. The sand hills on the verge of the ocean are carpeted with creepers and the wild convolvulus. Inland, it spreads out into prairies of coarse long grass and scrub jungle, which harbour wild animals in plenty; but throughout this vast region there is scarcely a hamlet, and only patches of rice cultivation at long intervals. From any part of the Salt Tract one may see the boundary of the inner arable part of the district, fringed with long lines of trees, from which every morning the villagers drive their cattle out into the saliferous plains to graze. The Salt Tract is purely alluvial, and appears to be of recent date. Towards the coast the soil has a distinctly saline taste.

Salt is largely manufactured in this tract by evaporation. The following is the process followed:—At the beginning of December the contractor selects his locality, about a quarter to half a mile from the sea, and engages a class of men called *chuliyás*, or heads of salt gangs. These men receive 1s. a cwt. for whatever amount of salt they turn out. They, in their turn, engage working parties of *malangis*, who are paid at the rate of 3d. to 5d. a day. The ground is first marked out by a shallow trench, and the grasses and bushes are carefully dug up and removed. A deep ditch is next dug from the sea, by means of which, twice a month, the spring tides overflow the salt-field, and fill a number of reservoirs, 4 feet in diameter, and 2 or 3 feet deep. A mound of earth is then piled up to the height of 2 feet, and from 3 to 4 in diameter. It is next hollowed out into the shape of a bowl, plastered inside with clay, and furnished with a hole at the bottom, covered with a layer of grass 6 inches thick. The salt-makers fill this bowl with saline earth scraped off the adjacent land, and pour the sea-water on it from the top. By the end of

six hours the water has drained through into a pit at the bottom, and runs down a thatched trench towards a reservoir, whence it is transferred to the evaporators. The latter consist of from 160 to 200 little unglazed earthenware pots, fastened together by stiff tenacious mud, and holding two quarts each. The neighbouring plains supply grasses for the fuel. Six hours' boiling completes the process. The brine, which consisted in the first place of sea-water charged to its maximum power of solution by percolating through the bowls of salt earth, subsides into dirty crystals at the bottom of the pots. It is then ladled out in spoons made of half cocoa-nuts. The whole process is as rude and careless as can well be imagined. The total cost of manufacture is estimated at 2s. 1d. a cwt., which with the Government duty of 8s. 8d., makes a total cost of 10s. 9d.

The Arable Tract lies beyond the salt lands, and embraces the chief part of the district. It is a long dead level of rich fields, with a soil lighter in colour than that of Bengal or Behar; much more friable, and apt to split up into small cubes with a rectangular cleavage. A peculiar feature of the Arable Tract is the *Pátt*, literally the Cups, or depressed lands near the river banks. They were probably marshes that have partially silted up by the yearly overflow of the streams. These Cup-lands bear the finest crops. As a whole, the Arable Tract is a treeless region, except around the villages, which are encircled by fine mango, *pipal*, banyan, and tamarind trees, and intersected with green shady lanes of bamboo. A few palmyras, date palms, and screw pines (a sort of aloe, whose leaves are armed with formidable triple rows of hook-shaped thorns) dot the expanse, or run in straight lines between the fields. The Submontane Tract is an undulating country with a red soil, much broken up into ravines along the foot of the hills. Masses of laterite, buried in hard ferruginous clay, crop up as rocks or slabs. At *Kopári*, in Kila Ambohatá, about 2 square miles are almost paved with such slabs, dark red in colour, perfectly flat, and polished like plates of iron. A thousand mountain torrents have scooped out for themselves picturesque ravines, clothed with an ever-fresh verdure of prickly thorns, stunted gnarled shrubs, and here and there a noble forest tree. Large tracts are covered with *Sál* jungle, which nowhere, however, attains to any great height.

Balasor district is watered by six distinct river systems: 1. The *Subanrekhá*, literally the streak of gold, forms the boundary between Balasor and Midnapur, flowing in a tortuous southern course, with gigantic bends from east to west till it reaches the sea in lat. 21° 35' N. and long. 87° 23' E. It is navigable by country craft as high as *Kálákápur*, about 16 miles from the mouth, to which point the tide also runs. Rice boats of 2 tons' burden can make their way up to the end of the Balasor district, and during the rains far into the tributary state of Morbhanj. 2. The intermediate country on the south of the *Subanrekhá* and the north of the *Burábalang*, forms a great line of drainage down from Morbhanj. It is watered by a number of small streams, of which the principal are the *Jamirá*, *Bána*, and *Bhairingi*. They unite, bifurcate, and re-unite in the wildest confusion, and at length enter the sea as the *Pánchpárá*, in lat. 21° 31' N. and long. 87° 10' E. 3. South of this network of rivers is the *Burábalang*, literally the Old Twister. It rises among the Morbhanj hills, in lat. 21° 24' and long. 86° 36', and after receiving two small tributaries, the *Gangáhar* and *Sunad*, wriggles into the sea in lat. 21° 28' and long. 87° 5'. Brigs, sloops, and sea-going steamers can navigate this river as far as the town of Balasor, about 16 miles up its twisting course, but the sand-bar across the mouth of the river renders the entrance difficult. 4. South of the *Burábalang*, a network of rivers, known as the *Jamká*, find their way down the line of drainage from the western Nilgiri hills, and enter the sea by many channels. 5. The *Kánshána*, rising in Kila Ambohatá, runs in a south-easterly direction, at first almost parallel with the Nilgiri hills, and receives from them a number of nameless drainage streams on its northern bank. At *Birpárá* it bifurcates, the northern branch retaining its original name, and entering the sea in lat. 21° 12' 25" long. 86° 52' 10". The southern branch receives the name of *Gammai*, and falls into the sea 6 miles south of the *Kánshána*. This river is navigable only

a few miles up, but is celebrated for its sudden floods and the vast extent of country which it submerges in the rainy season. 6. The Baitarani enters the district at the village of Balipur, and flows for about 45 miles in a south-westerly direction till it joins the Dhāmra, 5 miles from its mouth. The united stream enters the sea under the name of the Dhāmra, in lat. 20° 47', long. 87°. The Dhāmra is a fine navigable estuary, but, like all the Orissa rivers, it is rendered perilous by a bar across its mouth.

Population of Balasor in 1872, 770,232 souls, residing in 3266 villages, and 138,913 houses; persons per square mile, 378; villages per square mile, 1·58; persons per village, 236; houses per square mile, 67; persons per house, 5·5. Of the total population 738,396, or 95·9 per cent., were Hindus; 18,878, or 2·4 per cent., Mahometans; 530, or 1 per cent., Christians: 1 Buddhist; and 12,427, or 1·6 per cent., of aboriginal origin. The proportion of males to the total district population was 49·2 per cent.; number of male adult agriculturists, 150,391, and male adult non-agriculturists, 82,542. Brāhmins, Karans, Khandāits, and other castes, compose the Hindu population. There are two settlements of Christian missionaries in the district belonging to the Frewill Baptists, from Dover, New Hampshire, U.S. The district contains only one town with upwards of 5000 inhabitants, viz., Balasor itself, with 18,263. Almost the whole population of the district lives by agriculture. Rice forms the staple crop of the district, and is divided into 5 great *genera*, and 49 principal varieties. Pulses, oil-seeds, hemp, tobacco, cotton, sugar-cane, &c., make up the other agricultural products of Balasor. Balasor husbandmen consist of two classes, *thāst* or cultivators, with a right of occupancy, and *patā*, or tenants at will. Roughly speaking, one half of the district is under tillage, and the other half incapable of cultivation. Exports—Grain, sugar, oil-seeds, timber, hides, horns, &c. Imports—Native cloths, English piece-goods, &c. Fotal revenue of the Balasor district in 1870-71, £102,052, of which £41,408, or 40 per cent., was from land, total expenditure in the same year, £51,620. In 1872 the police force of the district consisted of 568 officers and men of the regular police, maintained at a total cost of £8879, 8s.; 32 officers and men of the municipal police, maintained at a cost of £224, 12s.; and 2320 men of the village watch, maintained by grants of service lands and by subscriptions from villages, which amounted to £2745 in 1872; total strength of police, 2918 men; total cost, £11,849. Balasor contained 1053 schools in 1872, attended by 11,538 pupils. The Government and aided schools were 43 in number, attended by 1631 pupils, and maintained at a total cost of £1559, to which Government contributed £748, 16s. The climate of Balasor greatly varies according to the seasons of the year. The hot season lasts from March to June, but is tempered by cool sea breezes; from June to September the weather is close and oppressive; and from October to February the cold season brings the north-easterly winds, with cool mornings and evenings. (W. W. H.)

BALASOR, the principal town and administrative headquarters of the above district, situated on the River Bārbalang, in 21° 28' 45" N. lat., and 86° 59' 33" E. long., about 8 miles from the sea-coast as the crow flies, and 16 by the river. The English settlement of Balasor, formed in 1642, and that of Pippli in its neighbourhood, seven years earlier, became the basis of the future greatness of the British in India. The servants of the East India Company here fortified themselves in a strong position, and carried on a brisk investment in country goods, chiefly cottons and muslins. They flourished in spite of the oppressions of the Mahometan governors, and when needful asserted their claims to respect by arms. In 1688, affairs having come to a crisis, Captain Heath, commander of the Company's snips, bombarded the town. In the 18th century Balasor rapidly declined in importance, on account of a dangerous bar which formed across the mouth of the river. At present the bar has 12 to 15 feet of water at spring tides, but not more than 2 or 3 feet at low water in the dry season. Large ships have to anchor outside in the open roadstead. The town contains a population of 18,263; municipal income in 1872, £519; expenditure, £514; rate of taxation, 6jd. per head of population. (w. w. h.)

BALBI, ADRIAN, one of the most eminent geographers of modern times, was born at Venice in 1782. In 1820 he visited Portugal, and there collected materials for his well-known work entitled *Essai Statistique sur le Royaume de Portugal et d'Algarve*, which was published at Paris in 1822. This was followed by *Variétés Politiques et Statistiques de la Monarchie Portugaise*, which contains some

curious observations respecting that country under the Roman sway, and on the state of literature and the arts. In 1826 he published the first volume of his *Atlas Ethnographique du Globe*, &c., a work of great erudition, embodying the researches of the most distinguished German philologists and geographers. In 1832 appeared the *Abregé de Géographie*, which added greatly to the author's reputation. This work, in an enlarged form, was translated into the principal languages of Europe. Balbi afterwards retired to Padua, where he continued to pursue his favourite science with unabated ardour. Besides those already mentioned, he was the author of several other works in the same department of science. He died on the 14th of March 1848.

BALBO, CESARE, an important Italian writer and statesman, was born at Turin, November 21, 1789. His father, Prospero Balbo, held a high position in the Piedmontese court, and at the time of Cesare's birth was syndic of the capital. His mother, a member of the Azeglio family, died when he was three years old; and he was brought up in the house of his great-grandmother, the countess of Bugino, "a noble and proud old lady." In 1798 he joined his father at Paris. From 1808 to 1814 Balbo served in various capacities under the Napoleonic empire, helping, at Florence and Rome, to fix the chains of despotism on his country. Gradually, however, his eyes were opened, and, on the fall of Napoleon, he was ready, in various capacities, to serve the cause of his country. While his father was appointed minister of the interior, he entered the army, and undertook political missions to Paris and London. On the revolution of 1821 he was forced into exile, and though, not long after, he was allowed to return to Piedmont, all active service as a statesman was denied him. Reluctantly, and with frequent endeavours to obtain some appointment, he gave himself up to literature as the only means left him to influence the destinies of his country. This accounts for the fitfulness and incompleteness of so much of his literary work, and for the practical, and in many cases temporary, element that runs through even his most elaborate productions. The great object of his labours was to help in securing for Italy that independence from foreign control which, even more than internal freedom, he regarded as the first necessity of national life. Of true Italian unity he had no expectation and no desire. A confederation of separate states under the supremacy of the Pope was the genuine *beau idéal* of Balbo, as it was the ostensible *beau idéal* of Gioberti. But Gioberti, in his *Primato*, seemed to him to neglect the first essential of independence, which he accordingly inculcated in his *Speranze* or *Hopes of Italy*. Preparation, both military and moral, alertness, and patience, were his constant themes. He did not wish revolution, but reform; and thus he became the leader of a moderate party, and the steady opponent not only of despotism but of democracy. At last, in 1848, his hopes were so far satisfied by the constitution granted by the king. He was appointed a member of the commission of electoral law, and held a post in the first reformed government. With the ministry of Azeglio, which soon after got into power, he continued on friendly terms, and his pen continued the active defence of his political principles till his death, on the 3d June 1853. The most important of his writings are historico-political, and derive at once their majesty and their weakness from his theocratic theory of Christianity. His style is clear and vigorous, and not unfrequently terse and epigrammatic. He published *Quattro Novelle* in 1829; *Storia d'Italia* in 1830, *Vita di Dante*, 1839; *Meditazioni Storiche*, 1842-5; *La Speranze d'Italia*, 1843; *Sommario della Storia d'Italia*.

BALBOA, VASCO NUÑEZ DE, one of the bravest and most successful of the Spanish discoverers of America, was born at Xeres de los Caballeros, in Estremadura, about the

year 1475. He was by birth a *hidalgo*, or gentleman, but was in poor circumstances. Little is known of his life till the year 1501, when he was one of the company of adventurers who followed Rodrigo de Bastidas in his voyage of discovery to the western seas. He appears to have settled in Hispaniola, and took to cultivating land in the neighbourhood of Salvatierra, but, with no great success, as his debts soon became oppressive. In 1509 the famous Ojeda sailed from San Domingo with an expedition, and founded the settlement of San Sebastian. He had left orders with Enciso, an adventurous lawyer of the town, to fit out two ships and convey provisions to the new settlement. Enciso set sail in 1510, and Balboa, whose debts made the town unpleasant to him, managed to accompany him, by concealing himself in a cask which was conveyed from his farm to the ship as if containing provisions. The expedition, after various adventures, reached San Sebastian to find Ojeda gone and the settlement in ruins. While Enciso was undecided how to act, Vasco Nuñez proposed that they should sail for Darien, on the Gulf of Uraha, where he had touched when with Bastidas. His proposal was at once accepted, and carried out. The new town was named *Santa Maria de la Antigua del Darien*. Bitter quarrels soon broke out among the adventurers, caused chiefly by Enciso prohibiting all private interchange for gold with the natives. Enciso was deposed from the office of authority which he had assumed, but it was found no easy matter to elect a successor. Nicuesa, in whose province they were, was proposed by several, and was brought from Nombre de Dios by a ship which had been sent out to bring assistance to him. The inhabitants of Darien, however, would not receive him, and, in their wrath, seized him and placed him, with seventeen companions, in a crazy bark with which to find his way back to Hispaniola. The party of Vasco Nuñez grew strong; Enciso was thrown into prison, and finally sent off to Spain along with Vasco's ally, the *alcalde* Zamudio. Being thus left in authority, Balboa began to make excursions into the surrounding country, and by his bravery and conciliatory manners gained the friendship of several native chiefs. On one of these excursions he heard for the first time of the great ocean that lay on the other side of the mountains, and of the wondrous land of gold, afterwards called Peru. Soon after his return to Darien he received letters from Zamudio, informing him that Enciso had complained to the king, and had obtained a sentence condemning Balboa and summoning him to Spain. In his despair at this message Vasco resolved to attempt some great enterprise, the success of which he trusted would conciliate his sovereign. On the 1st September 1513, he set out with about 190 men, well armed, and sailed to Coyba, where he left half his forces to guard the canoes and ships. With the remainder he started on his perilous journey across the isthmus. On the 26th September they reached the summit of the range of mountains, and the glorious expanse of the Pacific was displayed to them. Three days later, they began to descend the mountains on the western side, and Vasco, arriving at the sea-shore, formally took possession of the ocean in the name of the Spanish monarch. He remained on the coast for some time, heard again of Peru, had the Pearl Islands pointed out to him, and set out for Darien. On the 18th January 1514 he reached the town, and was received with the utmost joy. He at once sent messengers to Spain bearing presents, to give an account of his discoveries; but, unfortunately, these did not arrive till an expedition had sailed from Spain, under Don Pedro Arias de Avila (generally called Pedrarias, or Davila), to replace Vasco Nuñez, and to take possession of the colony. For some time after Pedrarias reached Darien Vasco was in great straits, but at length letters came from the king,

announcing to him his satisfaction with his exploits, and naming him *Adelantado*, or admiral. Pedrarias was prevailed upon to be reconciled with Vasco, and gave him one of his daughters in marriage. Vasco then resolved to accomplish his grand project of exploring the western sea. With infinite labour materials for building ships were conveyed across the isthmus, and two brigantines were constructed. With these the adventurers took possession of the Pearl Islands, and, had it not been for the weather, would have reached the coast of Peru. This career of discovery was stopped by the jealousy of Pedrarias, who feared that Balboa would throw off his allegiance, and who enticed him to Acla by a crafty message. As soon as he had him in his power, he threw him into prison, had him tried for treason, and forced the judge to condemn him to death. The sentence, to the grief of all the inhabitants, was carried into execution on the public square of Acla in 1517.

BALBRIGGAN, a seaport of Ireland, in the county of Dublin and parish of Balrothery, 18½ miles N.N.E. of the capital. The harbour, though dry at low tides, has a depth of 14 feet at high-water springs, and affords a good refuge from the E. or S.E. gales. It is formed by a pier 600 feet long, with a lighthouse at its extremity, in 53° 37' N. lat., 6° 12' W. long. A viaduct of eleven arches crosses the harbour. The town has considerable manufactures of cottons and hosiery, and is much frequented as a watering-place in summer. Population in 1871, 2332.

BALDE, JAKOB, a modern Latin poet of considerable reputation, was born at Ensisheim in Alsace in 1603, and died in 1668. He entered the Society of the Jesuits in 1624, and for the greater part of his life acted as court-preacher and professor of rhetoric at Munich. His Latin poems were very numerous, and those in imitation of Horace are particularly successful. Although Balde has received some attention since Herder translated several of his best pieces, and although some of his poems are by no means deficient in lightness, grace, and skilful verification, it would be a mistake to look upon him as a poet of high rank. A collected edition of his works in 4 vols. was published at Cologne in 1650; a more complete edition in 8 vols., at Munich, 1729. Extracts have been given by Orelli, 1805, 1818; and some detached poems have been published by various editors.

BALDI, BERNARDINO, a distinguished mathematician and miscellaneous writer, was descended of a noble family at Urbino, in which city he was born on the 6th of June 1533. He pursued his studies at Padua with extraordinary zeal and success, and is said to have acquired, during the course of his life, no fewer than sixteen languages, though according to Tiraboschi, the inscription on his tomb limits the number to twelve. The appearance of the plague at Padua obliged him to retire to his native city, whence he was, shortly afterwards, called to act as tutor to Ferrante Gonzaga, from whom he received the rich abbey of Guastalla. He held office as abbot for twenty-five years, and then retired to his native town. In 1612 he was employed by the duke as his envoy to Venice, where he distinguished himself by the congratulatory oration he delivered before the Venetian senate on the election of the new doge, Andrea Memmo. Baldi died at Urbino on the 12th of October 1617. He was, perhaps, the most universal genius of his age, and is said to have written upwards of a hundred different works, the chief part of which have remained unpublished. His various works give satisfactory evidence of his abilities as a theologian, mathematician, geographer, antiquary, historian, and poet. The *Cronica dei Matematici* is an abridgment of a larger work, on which he had bestowed twelve years of labour, and which was intended to contain the lives of more than two

hundred mathematicians. His life has been written by Affò, Mazzuchelli, and others.

**BALDINGER, ERNEST GOTTFRIED**, a German physician of considerable eminence, and the author of a great number of medical publications, was born near Erfurt, 13th May 1738. He studied medicine at Erfurt, Halle, and Jena, and in 1761 was intrusted with the superintendence of the military hospitals connected with the Prussian encampment near Torgau. He published, in 1765, a dissertation on the diseases of soldiers, which met with so favourable a reception that he published an enlarged edition, under the title of *Treatise on the Diseases that prevail in Armies*, Langensalza, 1774, 8vo. In 1768 he became professor of medicine at Jena, whence he removed, in 1773, to Göttingen, and in 1785 to Marburg, where he died of apoplexy on the 21st of January 1804. Among his pupils were Akermann, Sömmering, and Blumenbach. Some eighty-four separate treatises are mentioned as having proceeded from his pen, in addition to numerous papers scattered through various collections and journals.

**BALDINUCCI, FILIPPO**, a distinguished Italian writer on the history of the arts, was born at Florence about 1624, and died in 1696. His chief work is entitled *Notizie de Professori del Disegno da Cimabue in quà (dal 1260 sino al 1670)*, and was first published, in six vols. 4to, 1681–1728. The capital defect of this work is the attempt to derive all Italian art from the schools of Florence. A good edition is that by Ranalli (5 vols. 8vo, Florence, 1845–47). Baldinucci's whole works have been published in fourteen vols. at Milan, 1808–12.

**BALDOVINETTI, ALESSIO**, was a distinguished painter of Florence in the 15th century, whose works have now become very scarce. Hogarth takes him as a type of those obscure artists to whom the affected amateurs of his time were wont to ascribe old paintings—"Tis a fine piece of Alessio Baldovineti, in his third manner." His father, Baldovineti, belonged to a merchant family of good standing and fortune. Alessio was born in 1422, and took to painting, according to Vasari, against his father's desire. His art was distinguished rather for study than for genius. It represents completely some of the leading characters of the Florentine school in that age. It was an age of diligent schooling and experiment, in which art endeavoured to master more of the parts and details of nature than she had mastered heretofore, and to improve her technical means for their representation. Among the parts of nature especially studied in the 15th century, were landscape and natural history, the particulars of scenery, and the characters of birds, beasts, and plants. Alessio Baldovineti surpassed all his contemporaries in attention to these matters. In Vasari's words, you see in his paintings "rivers, bridges, stones, grasses, fruits, roads, fields, cities, castles, arenas, and an infinity of suchlike things." From this quality of his art it has been guessed, without sufficient cause, that he was the pupil of Paolo Uccelli, the first Florentine master who devoted himself to such matters. For the rest, this extreme care and minuteness renders his manner somewhat hard. Like many other painters of his time, he treats draperies, hair, and such parts, with a manner that shows the influence of the goldsmith, and is more proper to metal work than to painting. His principal extant works are a nativity in the church of the Annunziata, an altar-piece, No. 24, in the gallery of the Uffizi, and another, No. 2, in the gallery of ancient pictures in the Academy of Arts at Florence. The great work of his life was a series of frescoes from the Old Testament in the chapel of the Gianfigliuzzi family in the church of Sta Trinita; containing many interesting contemporary portraits; but these were destroyed about 1760. He also designed a likeness of Dante for the cathedral of Florence in 1465. His technical experiments

were of the same nature as those made by his contemporaries—Pesellino, Pollaiuolo, and Domenico Veneziano, who endeavoured to find out an oil medium at Florence before Antonello da Messina had brought to Venice the secrets of the Flemish practice. Vasari relates how Alessio thought he had made a great discovery with the mixture of yolk of egg and heated *vernice liquida*, but how the work so painted presently became discoloured. He understood mosaic as well as painting, and between 1481 and 1484 was engaged in repairing ancient mosaics, first in the church of San Miniato, next in the baptistery at Florence. He is said to have instructed Domenico Ghirlandaio (see BROGANI) in this art. He died on the 29th of August 1499, within two years and a half of the completion of his frescoes in the Gianfigliuzzi chapel. (Vasari, ed. Lemonnier, vol. iv. pp. 101–107; Crowe and Cavalasella, *Hist. of Painting in Italy*, vol. ii. pp. 372–381.) (s. a.)

**BALDUINUS, JACOBUS**, a distinguished professor of civil law in the university of Bologna. He was by birth a Bolognese, and is reputed to have been of a noble family. He was a pupil of Azo, and the master of Odofredus, of Hostiensis, and of Jacobus de Ravanis, the last of whom has the reputation of having first applied dialectical forms to legal science. His great fame as a jurist caused him to be elected *podestà* of the city of Genoa, where he was intrusted with the reform of the laws of the republic. He died at Bologna in 1225, and has left behind him some treatises on Procedure, which have the merit of being the earliest of their kind.

**BALDUR**, one of the most interesting figures of the Scandinavian mythology, was the son of Odin and Frigg. His name (from *baldr*, the foremost or pre-eminent one) denoted his supreme excellence and beauty. In the *Gylfeginning* we read that he was so amiable that all loved him, so beautiful that a light seemed to shine about him, and his face and hair were for ever refulgent. He was the mildest, wisest, and most eloquent of the *Æsir*; and when he pronounced a judgment, it was infallible. His dwelling was in Brejðablik (*far-sight*), where nothing impure could come, and where the most obscure question could be explained. The wonderful legend of his death is first dimly recorded in the *Völunga*, the grandest and most ancient of Eddaic poems, and more fully in the younger Edda. Baldur was visited by evil dreams, and felt his life to be in danger. His mother, Frigg, took oath of all things in the world, animal, vegetable, and mineral, that they should not slay her son. The gods being then secure, found pastime in setting the good Baldur in their midst, and in shooting or hurling stones at his invulnerable body. Then Loki, the evil god, took on him the form of a woman and went to Frigg in Fensal. From Frigg he learned that of all things in the earth but one could injure Baldur, and that was a little tree westward from Valhal, that was too young to take the oath. Thither went Loki and found the plant; it was the mistletoe. He plucked it up, fashioned it into an arrow, and went back to the *Æsir*. They were still in a circle, shooting at Baldur; and outside the ring stood the blind god Höder, of whom Loki asked wherefore he did not shoot. When Höder had excused himself because of his blindness, Loki offered to aim for him, and Höder, shooting the arrow of mistletoe, Baldur suddenly fell, pierced and dead. No such misfortune had ever yet befallen gods or men; there was long silence in heaven, and then with one accord there broke out a loud noise of weeping. The *Æsir* dared not revenge the deed, because the place was holy, but Frigg, rushing into their midst, besought them to send one to Hel to fetch him back. Hel promised to let him go if all things in heaven and earth were unanimous in wishing it to be so; but when inquiry was made, a creature called Thökt was found

in the cleft of a rock that said, "Let Hel keep its booty." This was Loki, and so Baldur came not back to Valhal. His death was revenged by his son Vale, who, being only one night old, slew Höder; but Loki fled from the revenge of the gods. In Baldur was personified the light of the sun; in his death the quenching of that light in winter. In his invulnerable body is expressed the incorporeal quality of light; what alone can wound it is mistletoe, the symbol of the depth of winter. It is noticeable that the Druids, when they cut down this plant with a golden sickle, did so to prevent it from wounding Baldur again. According to the *Völuspá*, Baldur will return, after Ragnarök, to the new heavens and the new earth; so the sun returns in spring to the renovated world. In the later versions it was no ordinary season, but the Fimbul winter, which no summer follows, which Baldur's death prefigured. It must not be overlooked that the story of Baldur is not merely a sun-myth, but a personification of that glory, purity, and innocence of the gods which was believed to have been lost at his death, thus made the central point of the whole drama of the great Scandinavian mythology. Baldur has been also considered, in relation to some statements of Saxo Grammaticus, to have been a god of peace,—peace attained through warfare; this theory has been advanced by Weinhold with much ingenuity. Several myths have been cited as paralleling the story of the death of Baldur; those of Adonis and of Persephone may be considered as the most plausible. (z. w. c.)

BALDUS, an eminent professor of the civil law, and also of the canon law, in the university of Perugia. He came of the noble family of the Ubaldi; and his two brothers, Angelus de Ubaldis and Petrus de Ubaldis, were almost of equal eminence with himself as jurists. He was born in 1327, and studied civil law under Bartolus at Perugia, where he was admitted to the degree of doctor of civil law at the early age of seventeen in 1344. Fredericus Petrus of Siena is said to have been the master under whom he studied canon law. Upon his promotion to the doctorate he at once proceeded to Bologna, where he taught law for three years; after which he was advanced to a professorial chair at Perugia, which he occupied for thirty-three years. He taught law subsequently at Pisa, at Florence, at Padua, and at Pavia, at a time when the schools of law in those universities disputed the palm with the school of Bologna. Baldus has not left behind him any works which bear out the great reputation which he acquired amongst his contemporaries. This circumstance may be in some respects accounted for by the active part which he took in public affairs, and by the fame which he acquired by his consultations, of which five volumes have been published by Diplovataccius. Baldus was the master of Peter Beaufort, the nephew of Pope Clement VI., who became himself Pope under the title of Gregory XI., and whose immediate successor, Urban VI., summoned Baldus to Rome to assist him by his consultations against the anti-pope Clement VII. Cardinal de Zabarella and Paulus de Castro were also amongst his pupils. His *Commentary on the Liber Fendorum* is considered to be one of the best of his works, which have been unfortunately left by him for the most part in an incomplete state.

BALDWIN, THOMAS, a celebrated English prelate of the 12th century, was born of obscure parents at Exeter, where, in the early part of his life, he taught a grammar school. After this he took orders, and was made archdeacon of Exeter; but he resigned that dignity, and became a Cistercian monk in the monastery of Ford in Devonshire, of which, in a few years, he was made abbot. In the year 1180 he was consecrated bishop of Worcester. In 1184 he was promoted to the see of Canterbury, and by Urban III.

was appointed legate for that diocese. He laid the foundation of a church and monastery in honour of Thomas à Becket at Hackington, near Canterbury, for secular priests; but being opposed by the monks of Canterbury and the Pope, he was obliged to desist. Baldwin then laid the foundation of the archiepiscopal palace at Lambeth. In 1189 he crowned King Richard I. at Westminster, and two years later, after making a pilgrimage through Wales to preach the Crusade, followed that prince to the Holy Land, where he died at the siege of Ptolemais or St Jean d'Acra. Giraldus Cambrensis, who accompanied him in an expedition through Wales, says he was of moderate habits and of an extremely mild disposition. He wrote various tracts on religious subjects, some of which were collected and published by Bertrand Tissier in 1662.

BALE, JOHN, Bishop of Ossory, in Ireland, was born at Cove, near Dunwich in Suffolk, in November 1495. He was educated in the monastery of the Carmelites at Norwich, and afterwards at Jesus College, Oxford. He belonged at first to the Roman Catholic Church, but was converted to the Protestant religion by Thomas Lord Wentworth. On the death of Lord Cromwell, the favourite of Henry VIII., who had protected him from the persecutions of the Romish clergy, he was obliged to take refuge in Flanders, where he continued eight years. Soon after the accession of Edward VI. he was recalled; and being first presented to the living of Bishop's Stocke (Bishopstoke), in Hampshire, he was nominated in 1552 to the see of Ossory, in Ireland. During his residence there he was remarkably assiduous in propagating the Protestant doctrines, but with little success, and frequently at the hazard of his life. On the accession of Queen Mary the tide of opposition became so powerful that, to avoid assassination, he embarked for Holland; and, after various vicissitudes, reached Basel in Switzerland, where he continued till the accession of Queen Elizabeth. After his return to England he was, in 1560, made prebendary of Canterbury, where he died in November 1563, in the sixty-eighth year of his age. Bale is noted as being one of the last (though not *the* last, as has sometimes been said) of those who wrote miracle-plays. Several of his are extant, and a list of titles of about twenty is given by Collier (ii. 238). They are remarkable for the determination they manifest to introduce and inculcate the doctrines of the Reformed religion. The best of his historical plays, *Kynge Johan*, has been published by the Camden Society, 1838. Of his numerous other works the most noted is his collection of British biography, entitled *Illustrium Majoris Britannia Scriptorum Catalogus, a Japheto sanctissimi Noah filio ad An. Dom. 1559*. This work was first published in quarto in 1548, and afterwards, with various additions, in folio, in 1557-59. Although slightly inaccurate, it is still a work of great value for the minute notices it gives of writers, concerning whom little is otherwise known. A selection from his works was published in 1849 by the Parker Society, containing the *Examinations of Cobham, Thorpe, and Anne Aakew, and the Image of the two Churches*. Bale's style is frequently coarse and violent, and his truthfulness has been sometimes challenged.

BALEARIC ISLANDS, a remarkable group in the western part of the Mediterranean Sea, lying to the S. and E. of Spain, between 38° 40' and 40° 5' N. lat., and between 1° and 5° E. long. The name, as now employed, includes not only the ancient *Insula Baleares* (*Major* and *Minor*), but also the *Pityusæ* or Pine Islands, as the two more western were called. The origin of the name *Baleares* is a mere matter of conjecture, and the reader may choose any of the derivations usually offered with about an equal chance of not being right. On the other hand, it is obvious that the modern *Majorca* (or, in Spanish, *Maiorca*) and *Minorca*



(In Spanish, Menorca) are obtained from the Latin *Major* and *Minor*, through the Byzantine forms *Maiopina* and *Minopina*; while Iviza is plainly the older Ebusus, a name

of, probably, Carthaginian origin. The *Optiusa* of the Greeks (*Colubraria* of the Romans) is now known as Formentera.

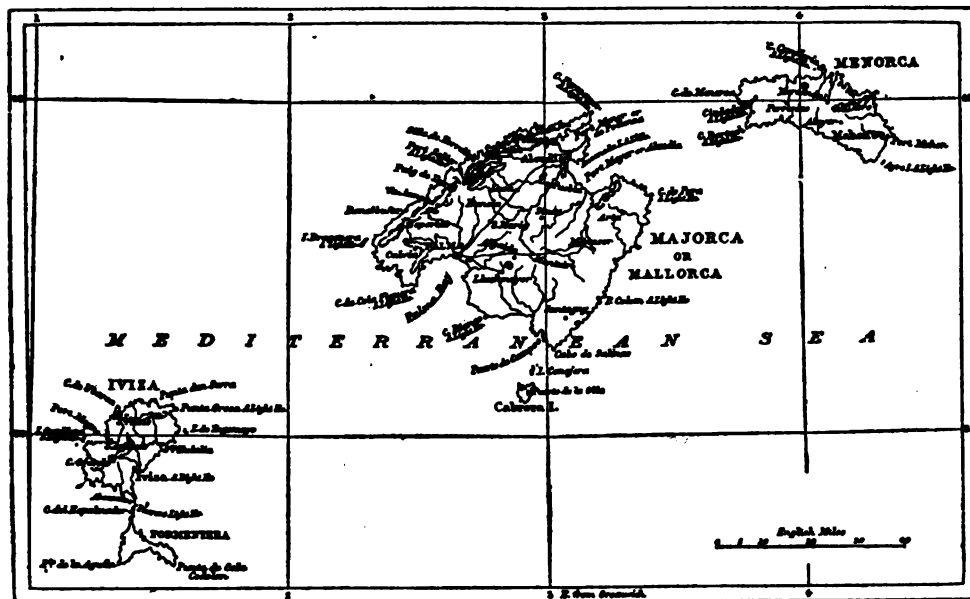

Sketch Map of the Balearic Islands.

Majorca is the largest island of the group, having an area of 1430 square miles. Its shape is that of a trapezoid, with the angles directed to the cardinal points; and its diagonal, from Cape Groszer in the W. to Cape Pera in the E., is about sixty miles. On the N.W. the coast is highly precipitous, but on the other sides it is low and sloping. On the N.E. there are several considerable bays, of which the chief are those of Alcudia and Pollenza; while on the S.W. is the still more important bay of Palma. No fewer than twelve ports or harbours are enumerated round the island, of which may be mentioned Andraix, Soller, and Porto Colom. In the N.W. Majorca is traversed by a chain of mountains running parallel with the coast, and attaining its highest elevation in Silla de Torillas, 4600 feet above the sea. Towards the south and east the surface is comparatively level, though broken by isolated peaks of considerable height. The northern mountains afford great protection to the rest of the island from the violent gales to which it is exposed, and render the climate remarkably mild and pleasant, while the heats of summer are tempered by the sea-breezes. The scenery of Majorca is varied and beautiful, with all the picturesqueness of outline that usually belongs to a limestone formation. Some of the valleys, such as those of Valdemossa and Soller, with their luxuriant vegetation, are delightful resorts. There are quarries of marble, of various grains and colours—those of Santagny, in the partido of Manacor, being especially celebrated; while lead, iron, and cinnabar have also been obtained. Coal of a jet-like character is found at Benisalem, where works were commenced in 1836, at Selva, where it has been mined since 1851, near Santa Maria, and elsewhere. It is used in the industrial establishments of Palma, and in the manufacture of lime, plaster, and bricks, in the neighbourhood of the mines,—a considerable quantity being also exported to Barcelona. The inhabitants are principally devoted to agriculture, and most of the arable land of the islands is under cultivation. The mountains are terraced;

and the old pine woods have in many places given place to the olive, the vine, and the almond tree, to fields of wheat and flax, or to orchards of figs and oranges. For the last-mentioned fruits the valley of Soller is one of the most important districts, the produce being largely transmitted to France, and realising about £25,000 per annum. The oil harvest is very considerable, and Inca is the centre of the oil district. The wines are light but excellent, especially the Muscadell and Montona. The agricultural methods of the islands are still somewhat primitive, but the introduction of machinery indicates improvement, as well as the drainage, by an English company, of a marsh and lake, 8000 acres in extent, near the town of Alcudia. During the summer there is often great scarcity of water; but, according to a system handed down by the Moors, the rains of autumn and winter are collected in enormous reservoirs, which contain sufficient water to last through the dry season; and on the payment of a certain rate, each landholder in turn has his fields flooded at certain intervals. Mules are used in the agriculture and traffic of the island. The cattle are small, but the sheep are large and well fleeced. Pigs are largely reared, and exported to Barcelona. There is abundance of poultry and of small game. A good deal of brandy is made and exported. Excellent woollen and linen cloths are woven. The silk-worm is reared, and its produce manufactured; and canvas, rope, and cord are largely made, from both native and foreign materials. The average value of the imports of the island is £350,000, and the exports amount to rather more. The roads are excellent, the four principal being those from Alcudia, Manacor, Soller, and Andraix to the capital. A railway is in course of construction from Palma by Inca to Alcudia, and the stock is all held by Mallorquins. A telegraphic line passes from Palma to Valcencia, and there is regular steam communication with Barcelona and Alicante. A Majorcan bank has been established, and a credit association for the development of the resources of

the island. The people are industrious and hospitable, and pique themselves on their loyalty and orthodoxy. They are often but poorly educated, and their superstition is great; crime, however, is rare. Vaccination is common throughout the island, except in the cities,—the women often performing the operation themselves when medical assistance cannot be got. Castilian is spoken by the upper and commercial classes; the lower and agricultural employ a dialect resembling that of the Catalans, with whom, also, their general appearance and manners connect them. Besides the towns already mentioned, Lluchmayor and Campos are places of considerable size; and the castle of Belbez near Palma, which was the former residence of the kings, is worthy of notice. Population of the island, 204,000.

Minorca, the second of the group in size, is situated 27 miles E.N.E. of Majorca. It has an area of 260 square miles, and extends about 35 miles in length. The coast is deeply indented, especially on the north, with numerous creeks and bays,—that of Port Mahon being one of the finest in the Mediterranean, if not the best of them all, as the complot of Andrea Doria quaintly puts it—

“Junio, Julio, Agosto, y puerto Mahon  
Los mejores puertos al Mediterraneo son” —

“June, July, August, and Port Mahon are the best harbours of the Mediterranean.” The ports Addaya, Fornelle, Ciudadela, and Nitja may also be mentioned. The surface of the island is uneven, flat in the south and rising irregularly towards the centre, where the mountain El Toro—probably so called from the Arabic *Tor*, a height, though the natives have a legend of a *toro* or bull—has an altitude of 5250 feet. Owing to want of shelter from mountains, the climate is not so equable as that of Majorca, and the island is exposed in autumn and winter to the violence of the north winds. The soil of the island is of very unequal quality; that of the higher districts being light, fine, and fertile, and producing regular harvests without much labour or cultivation, while that of the plains is chalky, scanty, and alike unfit for pasture and the plough. Some of the valleys have a good alluvial soil; and where the hills have been terraced, they are cultivated to the summit. The wheat and barley raised in the island are sometimes sufficient for home consumption; there is rarely a surplus. The *Hedysarum coronarium*, or sulla, as it is called by the Spaniards, is largely cultivated for fodder. Wine, oil, potatoes, legumes, hemp, and flax are produced in moderate quantities; fruit of all kinds, including melons, pomegranates, figs, and almonds, is abundant. The moniato, or sweet potato, is grown and exported to Algeria. The caper plant is common throughout the island, growing on ruined walls. Horned cattle, sheep, goats, &c., are reared, and the island abounds with small game. Stone of various kinds is plentiful; a soft stone, easily quarried, and acquiring hardness by exposure, is used for building. In the district of Mercadal and in Mount Santa Agueda are found marbles and porphyries superior to those of Italy, and lime and slate are also abundant. Lead, copper, and iron might be worked were it not for the scarcity of fuel. There are manufactures of the wool, hemp, and flax of the island; and formerly there was a good deal of boat-building; but, with the exception of agriculture, all branches of industry are comparatively neglected. The principal exports are wheat, cattle, cotton-stuffs, and shoes. An excellent road, constructed in 1713-15 by Brigadier Kane, to whose memory a monument was erected at the first milestone, runs through the island from S.E. to N.W., and connects Port Mahon with Ciudadela, passing by Alayor, Mercadal, and Ferrerias. Ciudadela, which was the capital of the island till Mahon was raised

to that position by the English during their occupancy of the island, still possesses considerable remains of its former importance. Population of the island, 39,000.

Iviza, Iviza, or, in Spanish, Ibiza, the *Ebusus* of the ancients, lies 50 miles S.W. of Majorca, and about 60 from Cape San Martin on the coast of Spain, between 38° 50' and 39° 8' N. lat., and between 1° 14' and 1° 38' E. long. Its greatest length from N.E. to S.W. is about 25 miles, and its greatest breadth about 13. The coast is indented by numerous small bays, the principal of which are those of San Antonio on the N.W., and of Iviza on the S.E. coast. Of all the Balearic group, Iviza is the most varied in its scenery and the most fruitful. The hilly parts are richly wooded. It was on one of the summits called Campey that one of the stations in the celebrated measurement of an arc of the meridian was placed. The climate is for the most part mild and agreeable, though the hot winds from the African coast are sometimes troublesome. Oil, corn, and fruits (of which the most important are the common fig, the prickly pear, the almond, and the carob-bean) are the principal productions of the island; but the inhabitants are rather indolent, and their modes of culture are very primitive. Hemp and flax are also grown. There are numerous salt-pans along the coast, which were formerly worked by the Spanish Government, but are now in the hands of a joint-stock company. Carob-beans, almonds, charcoal, and lead are the other articles of export, to which may be added stockings of native manufacture. The imports are rice, flour, and sugar, woollen goods, and cotton. The capital of the island, and, indeed, the only town of much importance,—for the population is remarkably scattered,—is Iviza or La Ciudad, a fortified town on the S.E. coast, consisting of a lower and upper portion, and possessing a good harbour. The population of the island is about 21,000, of whom 5500 are resident in the capital.

South of Iviza lies the smaller and more irregular island of Formentera, which is said to derive its name from the production of wheat. It is situated between 1° 22' and 1° 37' E. long. With Iviza it agrees both in general appearance and in the character of its productions, but it is altogether destitute of streams. Goats and sheep are found in the mountains, and the coasts are greatly frequented by flamingoes. The last station in the measurement of the arc of the meridian was in this island.

There are several smaller islands in the Balearic group, such as Cabrera, or Goat Island, and Conejera, or Rabbit Island, south of Majorca, but none of them are of any size or importance except Cabrera, which is full of caverns, and is used as a place of banishment. In 1808 it was the scene of a deed of gross barbarity—a large number of Frenchmen being landed on the island, and almost allowed to perish for want of food.

Of the origin of the early inhabitants of the Balearic Islands nothing is certainly known, though Greek and Roman writers refer to Bœotian and Rhodian settlements. According to general tradition the natives, from whatever quarter derived, were a strange and savage people till they received some tincture of civilisation from the Carthaginians, who early took possession of the islands, and built themselves cities on their coasts. Of these cities, Mahon, the most important, still retains the name which it derived from the family of Mago. About twenty-three years after the destruction of Carthage the Romans accused the people of the islands with piracy, and sent against them Q. Cædilius Metellus, who soon reduced them to obedience, settled amongst them 3000 Roman and Spanish colonists, founded the cities of Palma and Pollentia, and introduced the cultivation of the olive. Besides valuable contingents of the celebrated Balearic slingers the Romans derived from their new conquest mules (from Minorca), edible snails, *cinrops*, and pitch. Of their occupation numerous traces still exist,—the most remarkable being the aqueduct at Pollentia.

In 423 A.D. the islands were taken possession of by the Vandals, and in 798 by the Moors. They became a separate Moorish kingdom in 1009, which, becoming extremely obnoxious for piracy, was the object of a crusade directed against it by Pope Pascal II., in

which the Cabalans took the lead. This expedition was frustrated at the time, but was resumed by Don Jaime, king of Aragon, and the Moors expelled in 1232. During their occupation the island was populous and productive, and an active commerce was carried on with Spain and Africa. Don Jaime conferred the sovereignty of the isles on his third son, under whom and his successors they formed an independent kingdom up to 1349, from which time their history merges in that of Spain. In 1521 an insurrection of the peasantry against the nobility, whom they massacred, took place in Majorca, and was not suppressed without much bloodshed. In the war of the Spanish Succession all the islands declared for Charles; the duke of Anjou had no footing anywhere save in the citadel of Mahon. Minorca was reduced by Count Villars in 1707; but it was not till June 1715 that Majorca was subjugated, and meanwhile Port Mahon was captured by the English under General Stanhope in 1708. In 1718 the island was secured to them by the peace of Utrecht; but in 1756 it was invaded by a force of 12,000 French, who, after defeating the unfortunate Admiral Byng, captured Port Mahon. Restored to England in 1769 by the peace of Versailles the island remained in our possession till 1782, when it was retaken by the Spaniards. Again seized by the English in 1798, it was finally ceded to Spain by the peace of Amiens in 1803. When the French invaded Spain in 1808, the Mallorquins did not remain indifferent; the governor, D. Juan Miguel de Vives, announced, amid universal acclamation, his resolution to adhere to Ferdinand VII. At first the Junta would take no active part in the war, retaining the corps of volunteers that were formed for the defence of the island; but finding it quite secure, they transferred a succession of them to the Peninsula to reinforce the allies. Such was the animosity excited against the French when their excesses were known to the Mallorquins, that some of the French prisoners, conducted thither in 1810, had to be transferred with all speed to the island of Cabrera, a transferece which was not effected before some of them had been killed.

Armstrong's *Hist. of Minorca*, 1758 · Dameto's *Hist. del reyno Balearico o de Mallorca*; *Hist. of Balearic Islands*, London, 1716; Vincente Mut's *Historia*; Claghorn's *Diseases of Minorca*, 1751; Wernsdorf, *Antiquitates Balearicæ*; Clayton's *Sunny South*, 1869; George Sand, in *Revue des Deux Mondes*, 1841; D'Hermilly, *Hist. des Royaumes de Minorque, Maecricht, 1777*; "Balearic Islands," in Bates's *Illustrated Travels*, vol. 1.; *Die Balearen in Wort und Bild geschildert*, Leipzig, 1871; "Klima der Balearen" in the *Zeit. der Oesterr. Gesell. für Meteorologie*, 1874; Juan Ramis, *Antigüedades Celticas de la Isla de Menorca*, Mahon, 1818; Pauli, "Ein Monat auf den Balearen" in *Das Ausland*, 1873; Arago, *De ma jeunesse, Œuvres*, vol. 1.; Biot, *Recueil d'Observations géologiques, &c.*, 1821.

**BALLES, PETER**, a famous caligraphist, and one of the first inventors of short-hand writing. He was born in 1547, and is described by Anthony Wood as a "most dexterous person in his profession, to the great wonder of scholars and others." We are also informed that "he spent several years in sciences among Oxonians, particularly, as it seems, in Gloucester Hall; but that study, which he used for a diversion only, proved at length an employment of profit." He is mentioned for his skill in micrography in Hollingshed's *Chronicle*, anno 1575. "Hadrian Junius," says Evelyn, "speaking as a miracle of somebody who wrote the Apostles' Creed and the beginning of St John's Gospel within the compass of a farthing: what would he have said of our famous Peter Bales, who, in the year 1575, wrote the Lord's Prayer, the Creed, Decalogue, with two short prayers in Latin, his own name, motto, day of the month, year of the Lord, and reign of the queen, to whom he presented it at Hampton Court, all of it written within the circle of a single penny, inclosed in a ring and borders of gold, and covered with a crystal so accurately wrought as to be very plainly legible; to the great admiration of her majesty, the whole privy council, and several ambassadors then at court!" Bales was likewise very dexterous in imitating handwritings, and about 1576 was employed by Secretary Walsingham in certain political manœuvres. We find him at the head of a school near the Old Bailey, London, in 1590, in which year he published his *Writing Schoolmaster, in three Parts*. In 1595 he had a great trial of skill with one Daniel Johnson, for a golden pen of £20 value, and won it; and a contemporary author further relates that he had also the arms of caligraphy given him, which are asure, a pen or. Bales died about the year 1610.

**BALFE, MICHAEL WILLIAM**, was born, in 1808, at Limerick in Ireland. His musical gifts became apparent at an early age. The only instruction he received was from his father, and a musician of the name of Horn; and it seems to have been limited to a superficial training of the voice, and to some lessons on the pianoforte. At one time Balfe also practised the violin, and was even bold enough to play in public one of Viotti's concertos, but, seemingly, without much success. He never seems to have studied systematically the fundamental principles of his art, and this want of rudimentary training has left the stamp of imperfection on all his works. Being in possession of a small but pleasant barytone voice, he chose the career of an operatic singer, and made his *début* in *Der Freischütz*, at Drury Lane, at the early age of sixteen. The following year he was taken to Rome by a wealthy family. In Italy he wrote his first dramatic work, a ballet, *Perouse*, first performed at the Scala theatre, Milan, in 1826. In the later part of the same year he appeared as Figaro in Rossini's *Barbiere*, at the Italian Opera in Paris, at that time the scene of the unequalled vocal feats of such singers as Sontag, Malibran, Lablache, and others. Balfe's voice and training were little adapted to compete with such artists; he soon returned to Italy, where, during the next nine years, he remained singing at various theatres, and composing a number of operas, now utterly and justly forgotten. During this time he married the prima donna, Madda Luisa Roser, a lady of German birth, for whom one of his operas was written. He even made bold to disfigure, by interpolated music of his own, the works of Rossini, Donizetti, and other masters of established reputation. Fétis says that the public indignation, roused by an attempt at "improving" in this manner the opera *Il Crociato* by Meyerbeer compelled Balfe to throw up his engagement at the theatre La Fenice in Venice. He returned to England where, in 1835, his *Siege of Rochelle* was produced, and rapturously received at Drury Lane. Encouraged by his success, he produced a series of operas which for some time made him the most popular composer of the day. Amongst the works written for London we mention *Amelia, or the Love-test* (1838); *Falstaff* (with the incomparable Lablache as Sir John); *Keolanthe*; and the *Bohemian Girl* (1844). The last-mentioned work is generally considered to be his *chef d'œuvre*; it carried its composer's name to Germany, where it was performed with considerable success at various theatres. Balfe in the meantime also wrote several operas for the Opéra Comique and Grand Opéra in Paris, of which we may mention those called *Le Puits l'Amour*, *Les quatre Fils Aymon*, and *L'étoile de Seville*. After a short period of success his popularity began to decline, and at the time of his death in 1870, most of his music had become antiquated. A posthumous work of his, *The Tailor*, the libretto of which is taken from Walter Scott's novel, was performed at the Italian Opera, Drury Lane, in 1874, with considerable success. The chief charm of his works consists in a certain easy, not to say trivial, melodiousness, such as may be readily accounted for by the composer's Irish nationality without the addition of individual genius of a higher kind. He had also a certain instinct for brilliant orchestration, and for the coarser effects of operatic writing. Musical knowledge of a higher kind he never possessed, nor did he supply this want by the natural impulses of a truly refined nature. "To speak of Balfe as an artist is either to misuse the word or to permit its meaning to depend on temporary success, no matter how acquired." Such is the stern but not unjust verdict of the late Mr H. F. Chorley, whose opinion of the detrimental effect of Balfe's success "on the chances of establishing a real national opera" also appears to be correct. Balfe's claim to particular notice rests,

indeed, less on the intrinsic merits of his works than on their undoubted success; and, most of all, on the fact of his being one of the few composers of British birth whose names are known beyond the limits of their own country. (F. H.)

**BALFOUR, SIR JAMES**, of Pittendreich, at one time lord president of the Supreme Court in Scotland, an active and unscrupulous politician during the stormy period of the reign of Mary. He was originally educated for the church, and adopted the principles of the Reformers. With Knox and others he was condemned to the galleys on account of the part he had taken in the murder of Beaton, but after their release he abjured Protestantism, and speedily acquired great favour with the court, obtaining some considerable legal dignities. He was deeply implicated in the murder of Darnley, and drew up the bond which was signed by all the conspirators. As some reward for his services, he was made, by Mary, governor of Edinburgh Castle, a position in which he had a good opportunity for the exercise of his great talents for treachery. He yielded the castle to Murray on conditions favourable to himself alone, and then threw in his lot with the regent's party, by whose favour he secured the post of lord president. During the next few years he changed his political views more than once, but managed to keep in safety, though for a time he deemed it prudent to withdraw to France. On the accession of James he returned; and, after having had once to flee from Morton, now his deadly enemy, he brought about the destruction of that nobleman by producing the bond bearing upon Darnley's murder. He died not long after in 1583. The collection of statutes entitled the *Practicks* is generally ascribed to him; but it is not known how much of the book belongs to him and how much to Sir John Skene, his colleague in the task of arranging them.

**BALFOUR, SIR JAMES, Bart.**, of Denmylne and Kinnaird, an eminent annalist and antiquary, was born about 1600. He received a good education, travelled for some time on the Continent, and then devoted his attention almost entirely to the study of the history and antiquities of his country. He was well acquainted with Sir Wm. Segar and with Dugdale, to whose *Monasticon* he contributed. He was knighted by Charles I. in 1630, was made lyon king-at-arms in the same year, and in 1633 received the baronetcy of Kinnaird. He was removed from his office of king-at-arms by Cromwell, and died in 1657. Some of his works, which are very numerous, are preserved in the Advocates' Library at Edinburgh, together with his correspondence,—from which rich collection Mr Haig published *Balfour's Annals of Scotland from the reign 1057-1603*, in 4 vols. 8vo. (1824-25). See Sibbald, *Memoria Balfouriana*, 1699.

**BALFOUR, ROBERT**, a learned Scotchman, born about the year 1550, who was for many years principal of the Guienne College at Bordeaux. His principal work is his *Commentary on the Logic and Ethics of Aristotle* (Rurdig. [1616-20, 2 tom. 4to]), which is described by Dr Irving (*Lives of the Scottish Writers*) as uniting vigour of intellect with great extent and variety of learning. Balfour was one of the scholars who in the Middle Ages contributed to spread abroad over the Continent the fame of the *perfidivum ingenium Sctorum*.

**BALFROOSH**, or **BARFURŪSH**, a large commercial town of Persia, province of Mazanderan, on the River Bhowal, which is here crossed by a bridge of nine arches, about twelve miles distant from the southern shore of the Caspian Sea, where the small town of Meahed-i-Sir serves as a kind of port. Built in a low and swampy, though fertile country, and approached by deep and almost impassable roads, it would not seem at all favourably situated for the seat of an extensive inland trade. It is, however, peopled entirely

by merchants, mechanics, and their dependants, and is wholly indebted for its present size and importance to its commercial prosperity. The principal articles of its trade are rice, silk, and cotton. The town is of a very peculiar structure and aspect. It is placed in the midst of a forest of tall trees, by which the buildings are so separated from one another, and so concealed, that, except in the bazaars, it has no appearance of a populous town. The streets are broad and neat, though generally unpaved; and they are kept in good order. No ruins are to be seen, as in other Persian towns; the houses are comfortable, in good repair, roofed with tiles, and enclosed by substantial walls. There are no public buildings of any importance. The only places of interest are the bazaars, which extend fully a mile in length, and consist of substantially-built ranges of shops, covered with a roof of wood and tiles, and well stored with commodities. There are about ten principal caravansaries, and from twenty to thirty medresses or colleges, the place being as much celebrated for learning as for commerce. At the time of Fraser's visit (1822) it was said to contain 200,000 inhabitants, but this was probably an exaggeration. Since that time its population has undergone various fluctuations, and is now estimated at 125,000. Long. 52° 42' E., lat. 36° 37' N.

**BALGUY, JOHN**, an eminent English theologian and moral philosopher, was born at Sheffield on August 12, 1686. He received his early education partly under his father, and partly under Mr Daubuz, his father's successor, in the grammar-school of that town. He entered St John's College, Cambridge, in 1702, graduated Bachelor of Arts in 1706, was ordained to the ministry in 1710, and soon after obtained the small living of Lamesley and Tanfield in the county of Durham. He married in 1715. It was the year in which Bishop Hoadley preached that famous sermon on *The Kingdom of Christ*, which gave rise to the long, wearisome, and confused theological war known as the "Bangorian controversy," and Balguy, under the *nom de plume* of Silvius, began his career of authorship by taking the side of Hoadley in this controversy against some of his High Church opponents. In 1726 he published *A Letter to a Deist concerning the Beauty and Excellency of Moral Virtue, and the support and improvement which it receives from the Christian Religion*, chiefly designed to show that, while a love of virtue for its own sake is the highest principle of morality, religious rewards and punishments are most valuable, and in some cases absolutely indispensable, as sanctions of conduct. He supposed that a contrary opinion had been maintained by Lord Shaftesbury in his *Inquiry concerning Virtue*; but an examination of that essay will prove him to have in this respect done Shaftesbury injustice. In 1728 he was made a prebend of Salisbury by his friend, Bishop Hoadley. He published in the same year the first part of a tractate entitled *The Foundation of Moral Goodness*, and in the following year a second part, "illustrating and enforcing the principles contained in the former." The aim of the work is twofold— to refute the theory of Hutcheson regarding the basis of rectitude, and to establish the theory of Clarke. His objections to Hutcheson's theory are,—(1.) That it represents virtue as arbitrary and insecure by making it depend on two instincts, benevolent affection and the moral sense; (2.) That if true, brutes, since they have kind instincts or affections, must have some degree of virtue; (3.) That if such affections constitute virtue, the virtue must be the greater in proportion as the affections are stronger, contrary to the notion of virtue, which is the control of the affections; and (4.) That virtue is degraded by being made a result of instincts instead of being represented as the highest part of our nature. Clarke's fundamental ethical principle, that virtue is conformity to

reason,—the acting according to fitnesses which arise out of the eternal and immutable relations of agents to objects,—is the central and guiding thought in Balguy's moral speculations, and even the source of what is most distinctive in his theology. His exposition of it is characterised by insight into its significance, and by ingenuity in disposing of the objections which had been urged against it. In 1729 he became vicar of Northallerton, in the county of York. His next work was an essay on *Divine Rectitude*; or, a *Brief Inquiry concerning the Moral Perfections of the Deity, particularly in respect of Creation and Providence*. It is an attempt to show that the same moral principle which ought to direct human life may be perceived to underlie the works and ways of God: goodness in the Deity not being a mere disposition to benevolence, but a regard to an order, beauty, and harmony, which are not merely relative to our faculties and capacities, but real and absolute; claiming for their own sakes the reverence of all intelligent beings, and alone answering to the perfection of the divine ideas. It is only, Balguy thinks, when the divine rectitude is thus viewed as aiming at order no less than at happiness, as acting according to the true reasons of things no less than from the affection of benevolence, that such facts as the gift of freedom to man, the introduction and infliction of natural evil, the inequalities of human fortune, the sufferings of the righteous, and the prosperity of the wicked, can be satisfactorily explained. There followed *A Second Letter to a Deist, concerning a late book entitled "Christianity as old as the Creation," more particularly that chapter which relates to Dr Clarke*. Here Balguy argues that Tindal had falsely inferred revelation to be superfluous from the perfection of the law of nature and the ability of reason to discover that law. He grants that the law of nature is perfect and unchangeable, and that men can know whatever it is their duty to do, but maintains that the light of reason may have, and has had, added to it by revelation knowledge of great interest and value. This, he holds, is all that Clarke had maintained, and Tindal had failed to show that he had fallen into any self-contradictions. The same leading thoughts which we find in the tracts just mentioned meet us again in *The Law of Truth, or the Obligations of Reason essential to all Religion*. In this essay it is contended,—(1.) That reason binds or obliges, in the strictest sense of the word, all moral agents; (2.) That, considering men in their intellectual and moral capacity, the obligations of religion are entirely founded on the obligations of reason; and (3.) That on this ground, religion, whether natural or revealed, stands very firm and secure. Balguy collected these tracts and published them in a single volume in 1734, the *Letter to a Deist* and the *Foundation of Moral Goodness* having previously passed through three editions. In 1741 he published an *Essay on Redemption*, containing somewhat peculiar views. Redemption as taught in Scripture means, according to him, "the deliverance or release of mankind from the power and punishment of sin, by the meritorious sufferings of Jesus Christ," but involves no translation of guilt, substitution of persons, or vicarious punishment. Freed from these ideas, which have arisen from interpreting literally expressions which are properly figurative, the doctrine, he argues, satisfies deep and urgent human wants, and is in perfect consistence and agreement with reason and rectitude. His last publication was a volume of sermons, pervaded by good sense and good feeling, and clear, natural, and direct in style, but bearing few traces of the influence of the most distinctive and potent Christian motives. He died at Harrowgate, September 21, 1748. A second volume of sermons appeared shortly afterwards. The edition of his sermons most commonly met with is the 3d, in 2 vols., published in 1760. The notice of his life in the *Biographia Britannica* was written by his son. See

also Hunt's *Religious Thought in England*, vol. ii. 362-4, 454-6, iii. 87-9. Mr Hunt erroneously represents Shaftesbury and not Hutcheson as the philosopher assailed in the *Foundation of Moral Goodness*. (A. F.)

BALI, or LITTLE JAVA, one of the Sunda Islands, in the Eastern Seas, separated from Java by the straits of the same name, which are a mile and a half wide. It is 73 miles in length; its greatest breadth is 50 miles. A chain of mountains crosses the island in a direction E. and W., and terminates on the E. in the volcanic peak Gunung-agung, 12,379 feet above the sea-level. The climate and soil are the same as in Java; it has mountains of proportionate height, several lakes of great depth, and streams well fitted for the purposes of irrigation. Rice is produced in great quantities, and is even exported to Madura, Celebes, Timor, and Java. The other productions are tobacco, maize, pulses, oil, and salt; also cotton of an excellent quality. Coffee is now grown with great success; in the district of Teja Kulo alone, 150,000 trees were planted in the first four months of 1873. The inhabitants (estimated at about 800,000), though originally sprung from the same stock as those of Java, exceed them in stature and muscular power, as well as in activity and enterprising habits. "They have," says Sir Stamford Raffles, "a higher cast of spirit, independence, and manliness than belongs to any of their neighbours." They are good agriculturists and skilful artisans, especially in textile fabrics and the manufacture of arms. The imports are iron and cotton cloths, and opium to a great extent; in the district of Tabanan alone, forty chests of this drug are annually consumed. Both imports and exports are on the increase; but trade is chiefly in the hands of Europeans, Chinese, and Arabs, who have their firms or agents in Batavia, Surabaya, Makassar, and Singapore. The trade returns in the port of Padang Cove are estimated at £500,000 to £600,000 per annum; those of Buleleng and Jembrana were about £500,000 in 1873. The island is divided into the eight independent principalities of Buleleng, Karang Asam, Bangli, Tabanan, Mengui, Klongkong, Gyanyar, and Badong, each under its own ruler. The deputy-commissioner of Banyuwangi in east Java is also charged with the superintendence of the island of Bali in behalf of the Dutch Government. Though native rule is described as very tyrannical and arbitrary, especially in the principalities of Badong and Tabanan, trade and industry could not flourish if insecurity of persons and property existed to any great extent. The natives have also a remedy against the aggression of their rulers in their own hands; it is called *Mertilas*, consists in a general rising and renunciation of allegiance, and proves mostly successful. Justice is administered from a written civil and criminal code. Slavery is abolished. Hinduism, which was once the religion of Java, but has been extinct there for four centuries, is still in vogue in the islands of Bali and Lombok, where the cruel custom of widow burning is still practised, and the Hindu system of the four castes, with a fifth or Pariah caste (called *Chandalla*), adhered to. It appears partly blended with Buddhism, partly overgrown with a belief in *Kalas* or evil spirits. To appease these, offerings are made to them either direct or through the mediation of the *Devas* (domestic or agrarian deities); and if these avail not, the *Menyepi*, or Great Sacrifice, is resorted to. Buddhism prevails only in three districts. The Mahometan religion is said to be on the wane, in spite of the good influence it has exerted upon the people. Of the early history of their island the Balinese know nothing. The oldest tradition they possess refers to a time shortly after the overthrow of the Majapahit dynasty in Java, about the middle of the 15th century; but, according to Lassen, who identifies Bali with the island visited by

Jambulo, there must have been Indian settlers there before the middle of the 1st century, by whom the present name, probably cognate with the Sanskrit *balin*, strong, was in all likelihood imposed. It was not till 1633 that the Dutch attempted to enter into alliance with the native princes, and their earliest permanent settlement at Port Badong only dates from 1845. Their influence was extended by the results of the war which they waged with the natives about 1847-9. A geological survey of the whole island is at present (1874-5) in progress under their auspices. The Balinese language belongs to the same group of the Malayan class as the Javanese, Sundanese, Madurese, &c., but is as distinct from each of these as French is from Italian. It is most nearly akin to the Sasaak language spoken in Lombok and on the east coast of Bali. The literary language has embodied many of its ingredients from the Old Javanese, as spoken in Java at the time of the fall of Majapahit (15th century), while the vulgar dialect has kept free from such admixture. Javanese influence is also traceable in the use of three varieties of speech, as in the Javanese language, according to the rank of the people addressed. The alphabet is with some modifications the same as the Javanese, but more complicated. The material universally used for writing on is the prepared leaf of the lontar palm. The sacred literature of the Balinese is written in the ancient Javanese or Kawi language, which appears to be better understood here than it is in Java. (See R. van Eck, *Beknopte handleiding bij de beoefening van het Balinesche taal*, Utrecht, 1874.) In the years 1871 and 1872, 15,000 people died of small-pox in the island; since then vaccination has been introduced by the Dutch. In September 1874 several districts were fearfully ravaged by cholera; in Sampidi alone out of its 3000 inhabitants 700 fell victims to the scourge; the rest fled into the woods.

Crawford's *Descriptive Dictionary of the Indian Islands*, 1856; P. J. Veth, *Woordenboek van Nederlandch Indië*, 1869; *Tijdschrift voor Nederlandch Indië* for 1874, vol. ii. p. 439, *f.*; Lassen's *Indische Alterthumskunde*, iii. iv., *passim*; Friedrich's "Verlag van Bali" in *Travels of Batavian Soc. of Arts and Sci.*, xxiii., and a paper in the *Journal of the Ind. Arch.*, 1849; M. de Carrière's "Essai sur Bali" in *Le Montieur des Indes Orient.*, 1846-47; Dubois's *Vies des Gouverneurs-généraux*; Backer's *L'Archipel Indien*, 1874; *Jaarboek van het Nijnoezen in N. Ost.-Indië*, 1874.

BALIOLO, or BALLIOLO, SIR JOHN DE, an English baron, after whom Balliol College in Oxford has been named, was the son of Hugh Baliol, of Bernard's Castle, in the diocese of Durham. His great wealth and power raised him to a prominent position in the kingdom, and he rendered good service to Henry III. in his contest with De Montfort and the revolted barons. In 1263 he endowed several scholarships at Oxford, and formed the intention of founding a college. This he did not accomplish, but after his death in 1269, his widow, Devorgille or Devorguill, carried out his design, and the foundation received the name of Balliol College. Sir John's son was the well-known John Baliol, the competitor with Bruce for the throne of Scotland.

BALKAN (the ancient *Hæmus*), a mountain range that separates the waters of the Lower Danube from those that flow into the Archipelago; or, in the more extended application of the name, the whole mountain system from the Adriatic to the Euxine. The main chain has a mean elevation of 4000 or 5000 feet, and rises in various parts to a height of 7000 or 8000. Especially towards the east it breaks up into a number of parallel chains, and sends out various offshoots both south and north. Mount Scardus, the highest point of the Char-Dagh, attains to 9700 feet above the sea. The most of the rivers of the northern watershed find their way to the Black Sea, while those from the southern fall into the Mediterranean. The range is crossed by numerous defiles, most of which are left in a

nearly impassable condition, though they might in many cases be turned into serviceable routes. Communication is kept up between Vienna and Constantinople by the pass usually known as Trajan's Gate. Others of importance are the Nadir-Derbent, the Karnabud, and the Basardahik-Sophia. The mountains are for the most part of granitic formation, and are said to contain a variety of valuable minerals, but are still imperfectly known, in spite of the labours of Pouqueville, Boué, Viquesnel, Grisebach, Hahn, Barth, &c. Kanitz, between 1870 and 1874, crossed the eastern part no fewer than seventeen times by different passes.

See *Journey across Balkan by the Passes of Sellimao and Pravadi*, London, 1831; Joehinus's "Journey," 1847, in *Journ. Livy. Geog. Soc.*, 1854; *Nouvelles Annales des Voyages*, 2d series, vol. x; Petermann's *Mittheil.*, 1873-74.

BALKH, the ancient *Bactra* or *Zariaspa*, was formerly a great city, but is now for the most part a mass of ruins, situated on the right bank of the Adirishah or Balkh river, in a large and fertile plain 1800 feet above the sea. The modern name is, according to Vámbéry, the Turkish *balik*, or *balikh*, a city. The ruins, which occupy a space of about twenty miles in circuit, consist chiefly of fallen mosques and decayed buildings of sun-burnt brick. No monuments of pre-Mahometan date have been pointed out, if we except the bricks with cuneiform inscriptions which Ferrier asserts he observed; but nothing like a proper investigation of the site has yet been effected. The antiquity and greatness of the place are recognised by the native populations, who speak of it as the *Mother of Cities*. Its foundation is mythically ascribed to Kaiomurs, the Persian Romulus; and it is at least certain that, at a very early date, it was the rival of Ecbatana, Nineveh, and Babylon. For a long time the city and country was the central seat of the Zoroastrian religion, the founder of which is said to have died within the walls. From the *Memoirs of Hsuen Thsang*, a Chinese traveller, we learn that, at the time of his visit in the 7th century, there were in the city, or its vicinity, about a hundred Buddhist convents, with 3000 devotees, and that there was a large number of stupas, and other religious monuments. The most remarkable was the *Naw Behar*, *Nava Bihara*, or New Convent, which possessed a very costly statue of Buddha. A curious notice of this building is found in the Arabian geographer Yákrít. Ibn-Haukal, an Arabian traveller of the 10th century, describes Balkh as built of clay, with ramps and six gates, and extending half a parasang. He also mentions a castle and a mosque. El Edrisi, in the 12th century, speaks of its possessing a variety of educational establishments, and carrying on an active trade. There were several important commercial routes from the city, stretching as far east as India and China. In 1220 Genghis Khan sacked Balkh, butchered its inhabitants, and levelled all the buildings capable of defence,—treatment to which it was again subjected in the 14th century by Timur. Notwithstanding this, however, Marco Polo can still, in the following century, describe it as "a noble city and a great." Balkh formed the government of Aurungzebe in his youth. In 1736 it was conquered by Nadir Shah. Under the Durani monarchy it fell into the hands of the Afghans; it was conquered by Shah Murad of Kunduz in 1820, and for some time has been subject to the Khan of Bokhara.

See *Hsuen Thsang*, tr. by Julien, vol. I. pp. 29-33; Burnes's *Travels in Bokhara*, 1831-33; Ferrier's *Travels*; Vámbéry's *Bokhara*, 1873.

BALL, JOHN, a Puritan divine, of whom Baxter speaks in very high terms, was born, in 1585, at Cassington, or Chessington, near Woodstock, and died in 1640. He entered Brazenose College, Oxford, in 1602, and remained there five years. He then migrated to St Mary's Hall, from which he took his bachelor's degree in 1608. Soon after graduating he went into Cheshire to act as tutor to

the children of Lady Cholmondeley. While there he was thrown into the company of some enthusiastic Puritans, whose views he quickly adopted. He resolved upon entering the church, and, going up to London, obtained ordination from an Irish bishop. He was afterwards appointed to the small curacy of Whitmore, near Stoke, in Staffordshire, and here he passed the remainder of his life, eking out his miserable stipend by teaching a small school. The most popular of his numerous works was the *Short Treatise, containing all the Principal Grounds of Christian Religion*, which has passed through a great many editions, and has been in common use as a Puritan catechism. His *Treatise of Faith*, and *Friendly Trial of the Grounds tending to Separation*, the latter of which defines his position with regard to the church, are also valuable works.

**BALLADS.** The word ballad is derived from the Old French *baller*, to dance, and originally meant a song sung to the rhythmic movement of a dancing chorus. Later, the word became the technical term for a particular form of old-fashioned French poetry, remarkable for its involved and recurring rhymes. "Laissez moi aux Jeux Floraux de Toulouse toutes ces vieux poesies Françaises comme ballades," says Joachim du Bellay in 1550; and Phillaminte, the lady pedant of Molière's *Femmes Scavantes* observes—

"La ballade, a moi gout, est une chose fade,  
Ce n'en est plus la mode, elle sent son vieux temps."

In England the term has usually been applied to any simple tale, told in simple verse, though attempts have been made to confine it to the subject of this paper, namely, Popular Songs. By popular songs we understand what the Germans call *Folks-lieder*, that is, songs composed by the people, for the people, handed down by oral tradition, and in style, taste, and even incident, common to the people in all European countries. The beauty of these purely popular ballads, their directness and freshness, has made them admired even by the artificial critics of the most artificial periods in literature. Thus Sir Philip Sydney confesses that the ballad of *Chevy Chase*, when chanted by "a blind crowder," stirred his blood like the sound of trumpet. Addison devoted two articles in the *Spectator* to a critique of the same poem. Montaigne praised the *sauvétés* of the village carols; and Malherbe preferred a rustic *chansonnette* to all the poems of Bonnard. These, however, are rare instances of the taste for popular poetry, and though the Danish ballads were collected and printed in the middle of the 16th century, and some Scotch collections date from the beginning of the 18th, it was not till the publication of Allan Ramsay's *Evergreen* and *Tea Table Miscellany*, and of Bishop Percy's *Reliques*, that a serious effort was made to recover Scotch and English folk-songs from the recitation of the old people who still knew them by heart. At the time when Percy was editing the *Reliques*, Madame de Chénier, the mother of the celebrated French poet of that name, composed an essay on the ballads of her native land, modern Greece; and later, Herder and Grimm and Goethe, in Germany, did for the songs of their country what Scott did for those of Liddesdale and the Forest. It was fortunate, perhaps, for poetry, though unlucky for the scientific study of the ballads, that they were mainly regarded from the literary point of view. The influence of their artless melody and straightforward diction may be felt in the lyrics of Goethe and of Coleridge, of Wordsworth, of Heine, and of André Chénier. Chénier, in the most affected age even of French poetry, translated some of the Romaic ballads—one, as it chanced, being identical with that which Shakspeare borrowed from some English reciter, and put into the mouth of the mad Ophelia. The beauty of the ballads and the interest they excited led to numerous forgeries. It is probable that Hogg was as great a culprit in Scotland as Prosper Mérimée with his *Guita*, or collec-

tion of Servian imitations, in France. Editors could not resist the temptation to interpolate, to restore, and to improve the fragments that came in their way. The Marquis de la Villemarqué, who first drew attention to the ballads of Brittany, is not wholly free from this fault. Thus a very general scepticism was awakened, and when questions came to be asked as to the date and authorship of the Scottish traditional ballads, it is scarcely to be wondered at that Dr Chambers attributed most of them to the accomplished Lady Wardlaw, who lived in the middle of the 18th century.

The vexed and dull controversy as to the origin of Scottish folk-songs was due to ignorance of the comparative method, and of the ballad literature of Europe in general. The result of the discussion was to leave a vague impression that our native ballads were perhaps as old as the time of Dunbar, and were the production of a class of professional minstrels. These minstrels are a stumbling-block in the way of the student of the growth of ballads. The domestic annals of Scotland show that her kings used to keep court-bards, and also what strollers, *jongleurs*, as they were called, went about singing at the doors of farm-houses and in the streets of towns. Here were two sets of minstrels who had apparently left no poetry; and, on the other side, there was a number of ballads that claimed no author. It was the easiest and most satisfactory inference that the courtly minstrels made the verses, which the wandering crowdiers imitated or corrupted. But this theory fails to account, among other things, for the universal sameness of tone, of incident, of legend, of primitive poetical formulae, which the Scotch ballad possesses, in common with the ballads of Greece, of France, of Provence, of Portugal, of Denmark, and of Italy. The object, therefore, of this article is to prove that what has long been acknowledged of nursery tales, of what the Germans call *Märchen*, namely, that they are the immemorial inheritance at least of all European peoples, is true also of ballads. The main incidents and plots of the fairy tales of Celts, and Germans, and Slavonic and Indian peoples, their unknown antiquity and mysterious origin, are universally recognised. No one any longer attributes them to this or that author, or to this or that date. The attempt to find date or author for a genuine popular song is as futile as a similar search in the case of a *Märchen*. It is to be asked, then, whether what is confessedly true of folk-tales,—of such stories as the *Sleeping Beauty* and *Cinderella*,—is true also of folk-songs. Are they, or have they been, as universally sung as the fairy tales have been narrated? Do they, too, bear traces of the survival of primitive creeds and primitive forms of consciousness and of imagination? Are they, like *Märchen*, for the most part, little influenced by the higher religions, Christian or polytheistic? Do they turn, as *Märchen* do, on the same incidents, repeat the same stories, employ the same machinery of talking birds and beasts? Lastly, are any specimens of ballad literature capable of being traced back to extreme antiquity? It appears that all these questions may be answered in the affirmative; that the great age and universal diffusion of the ballad may be proved; and that its birth, from the lips and heart of the people, may be contrasted with the origin of an artistic poetry in the demand of an aristocracy for a separate epic literature, destined to be its own possession, and to be the first development of a poetry of personality,—a record of individual passions and emotions. After bringing forward examples of the identity of features in European ballad poetry, we shall proceed to show that they all sprang from the same primitive custom of dance, accompanied by improvised song, which still exists in Greece and Russia, and even in valleys of the Pyrenees.

There can scarcely be a better guide in the examination

of the *notes* or marks of popular poetry than the instructions which M. Ampère gave to the committees appointed in 1852-53 to search for the remains of ballads in France. M. Ampère bade the collectors look for the following characteristics:—"The use of assonance in place of rhyme, the brusque character of the recital, the textual repetition, as in Homer, of the speeches of the persons, the constant use of certain numbers,—as three and seven,—and the representation of the commonest objects of every-day life as being made of gold and silver." M. Ampère might have added that French ballads would probably employ a "bird-chorus," the use of talking-birds as messengers; that they would repeat the plots current in other countries, and display the same non-Christian idea of death and of the future world, the same ghostly superstitions and stories of metamorphosis, and the same belief in elves and fairies, as are found in the ballads of Greece, of Provence, of Brittany, Denmark, and Scotland. We shall now examine these supposed common notes of all genuine popular song, supplying a few out of the many instances of curious identity. As to brusqueness of recital, and the use of assonance instead of rhyme, as well as the aid to memory given by reproducing speeches verbally, these are almost unavoidable in all simple poetry preserved by oral tradition. In the matter of recurring numbers, we have the eternal—

"Trois belles filles

L'y en a's une plus belle que le jour,"

who appear in old French ballads, as well as the "Three Sailors," whose adventures are related in the Lithuanian and Provençal originals of Mr Thackeray's *Little Billet*. Then there is "the league, the league, the league, but barely three," of Scotch ballads; and the *τρία πουλακιά*, three golden birds, which sing the prelude to Greek folk-songs, and so on. A more curious note of primitive poetry is the lavish and reckless use of gold and silver. M. Tozer, in his account of ballads in the *Highlands of Turkey*, remarks on this fact, and attributes it to Eastern influences. But the horses' shoes of silver, the knives of fine gold, the talking "birds with gold on their wings," as in Aristophanes, are common to all folk-song. Everything almost is gold in the *Kalevala*, an epic formed by putting into juxtaposition all the popular songs of Finland. Gold is used as freely in the ballads, real or spurious, which M. Verkovich has had collected in the wilds of Mount Rhodope. The captain in the French song is as lavish in his treatment of his runaway bride,—

"Son amant l'habille,  
Tout en or et argent,"

and the rustic in a song from Poitou talks of his *faucille d'or*, just as a variant of Hugh of Lincoln introduces gold chairs and tables. Again, when the lover, in a ballad common to France and to Scotland, cuts the winding sheet from about his living bride—"il tira ses ciseaux d'or fin." If the horses of the Klephts in Romain ballads are gold shod; the steed in *Willie's Lady* is no less splendidly accoutred,—

"Silver shod before,  
And gowden shod behind,"

Readers of Homer, and of the *Chanson de Roland*, must have observed the same primitive luxury of gold in these early epics.

Next as to talking-birds. These are not so common as in *Märchen*, but still are very general, and cause no surprise to their human listeners. The omniscient popinjay, who "up and spoke" in the Border minstrelsy, is of the same family of birds as those that, according to Talvj, pervade Servian song; as the *τρία πουλακιά* which introduce the story in the Romain ballads; as the wise birds whose speech is still understood by exceptionally gifted Zulus; as the wicked dove that whispers temptation in the sweet

French folk-song; as the "bird that came out of a bush, on water for to dine," in the *Water o' Wearies Well*.

In the matter of identity of plot and incident in the ballads of various lands, it is to be regretted that no such comparative tables exist as Von Hahn tried, not very exhaustively, to make of the "story-roots" of *Märchen*. A common plot is the story of the faithful leman, whose lord brings home "a braw new bride," and who recovers his affection at the eleventh hour. In Scotland this is the ballad of Lord Thomas, and Fair Annie; in Danish it is Skiaen Anna. It occurs twice in M. Fauriel's collection of Romain songs. Again, there is the familiar ballad about a girl who pretends to be dead, that she may be borne on bier to meet her lover. This occurs not only in Scotland, but in the popular songs of Provence (collected by Damase Arbaud) and in those of Metz (Puymaigre), and in both countries an incongruous sequel tells how the lover tried to murder his bride, and how she was too cunning, and drowned him. Another familiar feature is the bush and briar, or the two rose trees, which meet and plait over the graves of unhappy lovers, so that all passers-by see them, and say in the Provençal,—

"Diou ague l'amo  
Des peures amoureux."

Another example of a very wide-spread theme brings us to the ideas of the state of the dead revealed in folk-songs. *The Night Journey*, in M. Fauriel's Romain collection, tells how a dead brother, awakened from his sleep of death by the longing of love, bore his living sister on his saddle-bow, in one night, from Baghdad to Constantinople. In Scotland this is the story of Proud Lady Margaret; in Germany it is the song which Bürger converted into Lenore; in Denmark it is Aagé und Elæ; in Brittany the dead foster-brother carries his sister to the apple close of the Celtic paradise (*Barras Breiz*). Only in Brittany do the sad-hearted people think of the land of death as an island of Avalon, with the eternal sunset lingering behind the flowering apple trees, and gleaming on the fountain of forgetfulness. In Scotland the channering worm doth chide even the souls that come from where, "beside the gate of Paradise, the birk grows fair enough." The Romain idea of the piece of the dead, the garden of Charon, whence "neither in spring or summer, nor when grapes are gleaned in autumn, can warrior or maiden escape," is likewise pre-Christian. In Provençal, Danish, and Yorkshire folk-song, the cries of children ill-treated by a cruel step-mother awaken the departed mother,—

"'Twas cold at night and the bairnies grat,  
The mother below the mools heard that."

She reappears in her old home, and henceforth, "when dogs howl in the night, the step-mother trembles, and is kind to the children." To this identity of superstition we may add the less tangible fact of identity of tone. The ballads of Klephtic exploits in Greece match the Border songs of Dick of the Law and Kinmont Willie. The same simple delight of living animates the short Greek *Scolia* and their counterparts in France. Everywhere in these happier climes, as in Southern Italy, there are snatches of popular verse that make but one song of rose trees, and apple blossom, and the nightingale that sings for maidens loverless,—

"Il ne chante pas pour moi,  
J'en ai un, Dieu merci,"

says the gay French refrain.

It would not be difficult to multiply instances of resemblance between the different folk-songs of Europe; but enough has, perhaps, been said to support the position that they are popular and primitive in the same sense as *Märchen*. They date from times, and are composed by



peoples who find, in a natural improvisation, a natural utterance of modulated and rhythmic speech, the appropriate relief of their emotions, in moments of high-wrought feeling or on solemn occasions. "Poesie" (as Puttenham well says in his *Art of English Poesie*, 1589) "is more ancient than the artificial of the Greeks and Latines, and used of the savage and uncivil, who were before all science and civilitie. This is proved by certificate of merchants and travellers, who by late navigations have surveyed the whole world, and discovered large countries, and wild people strange and savage, affirming that the American, the Perusine, and the very Canniball do sing and also say their highest and holiest matters in certain riming versicles." In the same way Aristotle, discoursing of the origin of poetry, says (*Poet.*, c. iv.), ἔθνησαν τῆν ποιήσιν ἐκ τῶν ἀνθρώπων ἀειμάτων. M. de la Villemarqué in Brittany, M. Pitré in Italy, Herr Ulrich in Greece, have described the process of improvisation, how it grows out of the custom of dancing in large bands and accompanying the figure of the dance with song. "If the people," says M. Pitré, "find out who is the composer of a *canzone*, they will not sing it." Now in those lands where a blithe peasant life still exists with its dances, like the *kolos* of Russia, we find ballads identical in many respects with those which have died out of oral tradition in these islands. It is natural to conclude that our ballads too were first improvised, and circulated in rustic dances. We learn from M. Bugeaud and M. de Puymaigre in France, that all ballads there have their air or tune, and that every dance has its own words, for if a new dance comes in, perhaps a fashionable one from Paris, words are fitted to it. Is there any trace of such an operatic, lyrical, dancing peasantry in austere Scotland? We find it in Gawin Douglas's account of—

" Sic as we clepe wenches and damocels,  
In gery greens, wandering by spring wells,  
Of bloomed branches, and flowers white and red,  
Pleatland their lusty chaplets for their head,  
Some sang ring-sangs, dances, ledes, and rounds."

Now, ring-sangs are ballads, dancing songs; and *Young Tamlane*, for instance, was doubtless once danced to, as we know it possessed an appropriate air. Again, Fabyan, the chronicler (quoted by Ritson) says that the song of triumph over Edward II. "was after many days sung in dances, to the carols of the maidens and minstrels of Scotland." We might quote the *Complaynt of Scotland* to the same effect. "The shepherds, and their wyvis sang mny other melodi sangs, . . . than efter this suet celestial harmony, the began to dance in a ring." It is natural to conjecture that, if we find identical ballads in Scotland, and in Greece, and Italy, and traces of identical customs,—customs crushed by the Reformation, by Puritanism, by modern so-called civilisation,—the ballads sprang out of the institution of dances, as they still do in warmer and pleasanter climates. It may be supposed that legends on which the ballads are composed, being found as they are from the White Sea to Cape Matapan, are part of the stock of primitive folk-lore. Thus we have an immemorial antiquity for the legends, and for the lyrical choruses in which their musical rendering was improvised. We are still at a loss to discover the possibly mythological germs of the legends; but, at all events, genuine ballads may be claimed as distinctly popular, and, so to speak, impersonal in matter and in origin. It would be easy to show that survivals out of this stage of inartistic lyric poetry linger in the early epic poetry of Homer and of the French *épopées*, and that the Greek drama sprang from the sacred choruses of village vintagers. In the great early epics, as in popular ballads, there is the same directness and simplicity, the same use of recurring epithets, the "green grass," the "salt sea," the "shadowy hills," the same

repetition of speeches, and something of the same barbaric profusion in the use of gold and silver. But these resemblances must not lead us into the mistake of supposing Homer to be a collection of ballads, or that he can be properly translated into ballad metre. The *Iliad* and the *Odyssey* are the highest form of an artistic epic, not composed by piecing together ballads, but developed by a long series of noble *doctos*, for the benefit of the great houses which entertain them, out of the method and materials of popular song. Ballads sprang from the very heart of the people; and fit from age to age, from lip to lip of shepherds, peasants, nurses, of all the class that continues nearest to the state of natural men. They make music with the plash of the fisherman's oars and the hum of the spinning-wheel, and keep time with the step of the ploughman as he drives his team. The country seems to have aided man in their making; the bird's note rings in them, the tree has lent her whispers, the stream its murmur, the village-bell its tinkling tune. The whole soul of the peasant class breathes in their burdens, as the great sea resounds in the shells cast up on the shores. Ballads are a voice from secret places, from silent peoples, and old times long dead; and as such they stir us in a strangely intimate fashion to which artistic verse can never attain.

The works of the following authors will be found useful to the student of ballads:—Talvj, *Charakteristik der Volkslieder*, dealing chiefly with the northern races of Europe, and with some African and Asiatic tribes; Kretschmar's *Volkslieder*; J. Grimm, in several treatises. For Brittany—Marquis de la Villemarqué's *Barzaz Breiz*; also M. Luzel's *Chansons Populaires*. For France—Bugeaud, *Chansons Populaires*; De Puymaigre (for the Metz district), Damas Arbaud (for Provence); Champfleury's large collection is rather miscellaneous. The quarterly journal, *Roumanie*, publishes many folk-songs. For Greece—Fauriel, Passow, Le Grand. For Italy—Pitré and Nigra. For Scotland—Scott, Jamieson, Motherwell. (A. L.)

BALLANCHE, PIERRE SIMON, a distinguished French philosopher of the theocratic school, was born at Lyons in 1776. His health from infancy was extremely delicate, his nervous system was weak, and he was frequently subject to hallucinations and mental disorders. This weakness was much aggravated by his experience of the horrors consequent on the insurrection at Lyons and the siege of that town, during which he and his mother were compelled to take refuge in the country. His education seems never to have been very complete; but he was early imbued with ideas on the construction of society, which naturally sprang from the events of the revolutionary period. His first literary effort was an epic poem, describing the occurrences at Lyons; this he never published. In 1801 he wrote an essay *Du Sentiment considéré dans la littérature et dans les Arts*, a work which shows very well the defects as well as the merits of his style and manner of thinking. It is essentially unsystematic; and the few good ideas contained in it are expressed in language so figurative that it costs an effort to discover what is really being said. Ballanche, indeed, was essentially unsystematic and unscientific, and seems to have had no conception of what is truly required in a philosophy. His style is not external to the thinking, but is indissolubly connected with it; strange thoughts and *bizarre* expressions arise together.

His next great work, the *Antigone*, a prose poem, published in 1814, was the fruit of long and quiet meditation, and was received with great favour by the brilliant literary society surrounding Chateaubriand and Mme. Récamier, into which Ballanche had been introduced. From this year, 1814, dates his serious effort towards a speculative reconstruction of society, an exposition of the *palingenesis* of social order. He transferred his residence to Paris, where he continued to live in communication with the few thinkers who had like philosophical tendencies with himself. In 1817 appeared his *Essai sur les Institutions*

*Sociales dans leur rapport avec les Idées nouvelles*, which was intended to serve as a prelude to his great tripartite social epic. The work is more intelligible than any other of Ballanche's; it advocates a moderate constitutional government, and was, on this account, misjudged by many, who fancied it recommended Bourbonism. A philosophical dialogue, *Le Vieillard et le Jeune Homme*, and a novel, *L'Homme sans Nom*, were written in 1819 and 1820. He then devoted himself to his great work, the *Palingénésie Sociale*. This, which was to be a *Theodicæa*, an exposition of the workings of God in history, was divided into three parts: the first reconstructed that period of the world which was before the rise of religion, which is prehistoric, or mythical; the second endeavoured, from a study of known history, to deduce a universal law or rule; the third sketched that state of things through and in which humanity at last attains its final end and crowning glory. The works representing these three parts were called *L'Orphée*, *La Formule*, and *La Ville des Expiations*; only the first was completed, but some fragments of the others are in existence. To the whole a general introduction was prefixed, which is the most valuable of all Ballanche's works. His latest writing, *Vision d'Hébal* (Hebal being the chief of a Scottish clan, and gifted with second sight), was evidently intended to form portion of the third part of the *Palingénésie*. In mystical language it gives vague and semi-prophetic utterances on the future course of world-history. It is by some considered his greatest production. Ballanche, who in 1841 had received the distinguished honour of a seat in the French Academy, died in 1847. He was much beloved by his friends, and seems to have been a most amiable, warm-hearted man, enthusiastic and poetical in temperament, whose intellect, however, was overshadowed by his imagination. A collected edition of his works was set on foot in 1830, and was intended to occupy nine vols. Only four appeared, and were republished in a smaller form in 1833.

It is almost impossible to give a connected view of Ballanche's fundamental ideas. As has been said, he belonged to the theocratic school, who, in opposition to the rationalism of the preceding age, emphasised the principle of authority, placing revelation above individual reason, order above freedom and progress. But Ballanche made a sincere endeavour to unite in one system what was valuable in the opposed modes of thinking. He held with the theocratists that individualism was an impracticable view; man, according to him, exists only in and through society. He agreed further with them that the origin of society was to be explained, not by human desire and efforts, but by a direct revelation from God. Lastly, with De Bonald, he reduced the problem of the origin of society to that of the origin of language, and held that language was a divine gift. But at this point he parts company with the theocratists, and in this very revelation of language finds a germ of progress. Originally, in the primitive state of man, speech and thought are identical; but gradually the two separate; language is no longer only spoken, it is also written, and finally is printed. Thus the primitive unity is broken up; the original social order which co-existed with, and was dependent on it, breaks up also. New institutions spring up, upon which thought acts, and in and through which it even draws nearer to a final unity, a rehabilitation, a *palingenesis*. The volition of primitive man was one with that of God, but it becomes broken up into separate volitions which oppose themselves to the divine will, and through the oppositions and trials of this world work onwards to a second and completer harmony. The history of humanity is therefore comprised in the fall from the perfect state, and in the return, after repeated trials, to a similar condition. In the dim,

shadowy records of mythical times may be traced the obscure outlines of primitive society and of its fall; and this is attempted in the *Orphée*. Actual history exhibits the conflict of two great principles, which may be said to be realised in the patricians and plebeians of Rome. Such a distinction of caste is regarded by Ballanche as the original state of historical society; and history, as a whole, he considers to have followed the same course as that taken by the Roman plebs in its gradual and successful attempts to attain equality with the patriciate. On the future events through which the human race shall achieve its destiny Ballanche gives few intelligible hints. The sudden flash which disclosed to the eyes of Hebal the whole epic of humanity cannot be reproduced in language trammelled by time and space. Scattered throughout the works of Ballanche are many valuable ideas on the connection of events which makes possible a philosophy of history; but his own theory, so far as it can be understood and judged, does not seem likely to find more favour than it has already met with.

See Ampère, *Ballanche*, Paris, 1848; Sta. Beuve, *Portraits Contemporains*, vol. ii.; Damiron, *Philosophie de XIX<sup>me</sup> Siècle*. An admirable analysis of the works composing the *Palingénésie* is given by Barchou, *Revue de deux Mondes*, 1831, t. 2. pp. 410-466.

**BALLARAT**, or **BALLAARAT**, a large and flourishing city of Australia, in the province of Victoria. It is situated about 58 miles N.W. of Geelong, with which it is connected by railway, and about 66 miles W.N.W. of Melbourne, at an elevation of 1437 feet above the level of the sea, on a small river known as the Yarowee Creek. It consists of three portions,—Ballarat West, Ballarat East, and Sebastopol,—each of which has its own municipality and town-hall. Its existence and prosperity are solely due to the gold-fields which were discovered here in 1851. In 1855 it was proclaimed a municipality, and in 1870 Ballarat West was raised to the rank of a city. In 1871 it contained 56 churches, 477 hotels, 10,000 dwellings, 11 banks, 8 iron-foundries, 13 breweries and distilleries, 3 flour-mills, a free public library, a mechanics' institute, a hospital, a "benevolent institution," a theatre, and a public garden; while about sixty miles of water-mains and fifty of gas-mains had been laid down. Its population—of very various origin, and including a large number of very degraded Chinese, who are huddled together in a separate quarter—then amounted to 48,156.

**BALLÁRI** [**BELLARY**], a district in the Madras Presidency, lies between 13° 40' and 16° 58' N. lat., 75° 44' and 78° 19' E. long. It is bounded on the N. by the Nizám's territory, from which it is separated by the Tungbhadrá river; on the E. by the districts of Kadapa and Karnul; on the S. by the Mysore country; and on the W. by Mysore, and the Bombay district of Dharwar. Its extreme length from north to south is 170 miles, and its breadth from east to west about 120 miles. The area of the district, including 145 square miles of the Sandúr State, is estimated at about 11,496 square miles; according to other returns, the area is 10,857 square miles (excluding Sandúr), of which 1004 consists of barren soil, sites of villages, beds of water-courses, &c., and 9852 of lands either actually cultivated or capable of cultivation. The census of 1871 returned the population at 1,652,044, of whom 94 per cent. were Hindus. It is estimated that 941,712, or 71·8 per cent. of the population, live by agriculture. The general aspect of the district is that of an extensive plateau between the Eastern and Western Gháts, of an average height of from 800 to 1000 feet above sea-level. The most elevated tracts are on the W., where the surface rises towards the culminating range of hills, and on the S., where it rises to the elevated table-land of Mysore. Towards the centre the surface of the plain presents a monotonous aspect, being almost treeless, and unbroken

are by a few rocky elevations that stand forth abruptly from the sheet of black soil below. The hill ranges in Ballári are those of Sandúr and Kampli to the W., the Lanká Malla to the E., and the Copper mountain to the S.W. The last has an elevation of 3148 feet. The district is watered by five hill streams, viz., the Tungbhadrá, formed by the junction of two small rivers, Tung and Bhadrá, the Haggári, Hindrí, Ponnár, and Chitravatí. The Ponnár is considered a sacred river by the natives. None of the rivers are navigable, and all are fordable during the dry season.

The agricultural products of the district are cotton, indigo, wheat, rice, sugar-cane, flax, betel, plantain, turmeric, chilies, onions, hemp, coriander, tobacco, areca-nut, cocoa-nut, oil-seeds, &c. The following is a rough estimate of acreage under different crops:—Food grains, 2,687,000 acres; oil-seeds, 108,000 acres; green and garden crops, 36,000 acres; orchards, 18,000 acres; cotton, indigo, and sugar-cane, 87,000 acres; fallow, 541,000 acres; total, 3,922,000 acres. The manufactures of the district consist of cotton goods, tape, carpets, rope, blankets, felts, dyes, oil, sugar and molasses, paper, leather, glass bangles or bracelets, and iron and earthen pots. Cotton, blankets, raw hides, iron, &c., form the articles of export. The chief mineral products are iron, copper, lead, antimony, manganese, alum, and gun-flints. Among precious stones diamonds are found, the chief diamond mines being at Munimadag and Wajrákard. The diamonds are collected in the sandstone breccia and conglomerate. The mines no longer yield sufficient profit to be regularly worked, though every now and then diamonds of small value are met with. The revenue of the Ballári district from all sources amounted in 1845 to £287,199; in 1855 to £248,284; and in 1868 to £322,542. The land tax forms the principal source of revenue. In 1868 it yielded £242,684. More than one-fourth of the lands are held as *ladm*, i.e., under grants formerly made for services or for religious purposes. These were very lightly taxed by the native Governments, but the present state of their assessment is not less than that of ordinary lands. The police force numbered 1122 in 1871, maintained at a cost of £16,012. In 1870-71 the district contained 153 schools, attended by 4274 pupils. It has only seven towns with a population of more than 7000 souls—(1), Ballári, population, including troops in the cantonment, 51,145; (2), Hospetá, 9845; (3), Tadipatrí, 8182; (4), Harpanhallí, 7895; (5), Báidrag, 7784; (6), Emmanganur, 7820; and (7), Yadki, 7202. Only four municipal towns exist in the district:—1. Ballári—population, 51,145; municipal income in 1871, £7651; expenditure, £7495; rate of taxation, 2s. 3½d. per head. 2. Gutti—population, 6038; municipal income, £992; expenditure, £930; rate of taxation, 2s. 3½d. per head. 3. Anantpur—population, 4971; municipal income, £794; expenditure, £784; rate of taxation, 2s. 3½d. per head. 4. Adoni—municipal income, £3147; expenditure, £1905. Fifty-nine roads, of a total length of 1466 miles, connect the different towns and villages in the Ballári district; and the Madras Railway, with a branch to Ballári, passes through it. The climate of Ballári is characterised by extreme dryness, in consequence of the air passing over a great extent of heated plains, and it has a smaller rainfall than any other district in South India. The average daily range of the thermometer is from 67° to 88°; average rain-fall for the five years ending 1869, 17 inches. The prevailing diseases are cholera, fever, small-pox, ophthalmia, dysentery, and skin diseases among the lower classes. Ballári is subject to disastrous storms and hurricanes, and to famines arising from a series of bad seasons. The storms of 1804 and 1851, and the famines of 1751, 1792, 1793, 1803, 1833, 1864, and 1866 still live in the popular memory.

Little is known of the early history of the district. It appears to have been a portion of the ancient kingdom of Vijayanagaram, and on the overthrow of that state in 1564 A.D. by the Mahometans, the tract now forming the district of Ballári was split up into a number of military holdings, held by chiefs called Poligáras. In 1635 the Carnatic was annexed to the Bijápur dominions, from which again it was wrested in 1680 by Sivaji, the founder of the Marhattá power. It was then included in the dominions of Nizám-ul-mulk, the nominal viceroy of the Great Mughul in the Dakhín, from whom again it was subsequently conquered by Heidar Ali of Mysor. At the close of the war with Tipú Sultán in 1792, the territories which now form the Ballári district fell to the share of the Nizám of Haidarábád, by whom it was ceded to the British in 1800, in return for a force of English troops to be stationed at his capital. In 1818 the district of Ballári was constituted as it at present remains. Amidst all these

political convulsions the little state of Sandúr, occupying a central position in the Ballári district, and surrounded by a cordon of hills, preserved its integrity. Sandúr can only be entered by one of three principal natural passes, viz., the Bhimagundi pass on the N.E., the Rámanagundi pass on the N., and the Oblagundi pass on the W. Its chief is the representative of one of the most ancient Marhattá families, and derives a revenue of £4500 from his state. He now holds Sandúr as a *Jagír* or military tenure from our Government, but pays no tribute.

BALLÁRI, the principal town of the above district, is the chief seat of the judicial and revenue establishments, and the headquarters of the military force in the ceded districts consisting of Ballári and Kadapa. The fort rises from a huge mass of granitic rocks, which jut up abruptly to a height of 450 feet above the plain, with a circumference of nearly 2 miles. Its length from north-east to south-west is about 1150 feet. To the E. and S. of the Ballári rock lies a heap of boulders irregularly piled one on the other, but to the W. is an unbroken surface of sheet-rock, while the N. is walled by bare rugged ridges. Ballári rock is defended by two distinct lines of works, the upper and the lower fort. The upper fort is a quadrangular building on the summit of the rock, with only one way up to it, and deemed impregnable by the Mysore princes. But as it has no accommodation for a garrison, it is now unoccupied by our troops, with the exception of a small guard in charge of prisoners. The ex-Nawáb of Karnúl was confined in it for forty years for the murder of his wife. It contains several tanks or cisterns excavated in the rock. Outside the turreted rampart are a ditch and covered way. The lower fort lies at the eastern base of the rock, and measures about half a mile in diameter. It contains the barracks for our troops, the arsenal and commissariat stores, the Protestant church, orphanage, Masonic lodge, post-office, and numerous private dwellings. The fort of Ballári was originally built by one Timmapa, in the 16th century. It was first dependent on the kingdom of Vijayanagaram, afterwards on Bijápur, and subsequently subject to the Nizám and Haidar Ali. The latter improved the fortifications with the assistance of French artisans, whom he afterwards hanged for not building the fort on a higher rock adjacent to it. The cantonment bázár of Ballári enjoys the reputation of being the best military bázár in Southern India. To the W. of the rock are the regimental lines for two Native infantry regiments, one European regiment, and one regiment of cavalry. On the E. are the jail, the public courts, and the terminus of the branch line of the Madras Railway. Ballári town, including the cantonment, contained in 1866 a population of 37,015 souls, of which 13,341 were Hindus, 4178 Mahometans, and 1042 Christians. Population ascertained by the census of 1871, 51,145. Elevation above the sea, 1600 feet. Distance from Bombay, S.E., 380 miles; from Madras, N.W., 370 miles. Lat. 15° 18' N.; long. 76° 59' E.

BALLATER, a village of Aberdeenshire, Scotland; on the River Dee, 42 miles W. from Aberdeen. In its vicinity are the medicinal wells of Pannanich, Balmoral Castle (a summer residence of Queen Victoria), and Ballatrich Farm, where Byron spent part of his boyhood. Ballatrich is a short distance from "Lachin-y-Gair" (Lochnagar), one of the loftiest of the Grampian range, and the subject of one of Byron's most beautiful poems.

BALLENSTEDT, a city in the duchy of Anhalt-Bernburg. It is situated on the Getal in the Harz Forest, in a most picturesque district, and consists of an old and a new town. A fine road, bordered with trees, leads to the castle of the dukes of Anhalt-Bernburg. The city contains about 4395 inhabitants, who are mostly engaged in linen manufactures, gardening, &c. Ballenstedt is the birthplace of Joh. Arndt.

**BALLET** is a word, the signification of which depends upon the century in which we find it employed. Originally derived from the Greek βαλλίζω, to dance, it has passed through the mediæval Latin *ballare* (with *ballator* as synonymous with *saltator*) to the Italian *ballars* and *ballata*, to the French *ballet*, to the old English word *ballette*, and to *ballad*. In old French, according to Rousseau, *ballet* signifies "to dance, to sing, to rejoice;" and thus it incorporates three distinct modern words, "ballet, ball, and ballad." Through the gradual changes in the amusements of different ages, the meaning of the first two words has at length become limited to dancing, and the third is now confined to singing. But, although ballads are no longer the vocal accompaniments to dances round the maypole, our old ballads are still sung to dance tunes. The present acceptation of the word *ballet* is—a theatrical representation in which a story is told only by gesture, accompanied by music which should be characterised by stronger emphasis than would be employed with the voice. The dancing should be connected with the story, but is more commonly incidental. The French word was found to be so comprehensive as to require further definition, and thus the above-described would be distinguished as the *ballet d'action* or pantomime ballet, while a single scene, such as that of a village festival with its dances, would now be termed a *divertissement*.

The *ballet d'action*, to which the changed meaning of the word is to be ascribed, and therewith the introduction of modern ballet, has been generally attributed to the 16th century. Novelty of entertainment was then sought for in the splendid courts of Italy, in order to celebrate events which were thought great in their time, such as the marriages of princes, or the triumphs of their arms. Invention was on the rack for novelty, and the skill of the machinist was taxed to the utmost. It has been supposed that the art of the old Roman *pantomimi* was then revived, to add to the attractions of court-dances. Under the Roman empire the *pantomimi* had represented either a mythological story, or perhaps a scene from a Greek tragedy, by mute gestures, while a chorus, placed in the background, sang *cantica* to narrate the fable, or to describe the action of the scene. The question is whether mute pantomimic action, which is the essence of modern ballet, was carried through those court entertainments, in which kings, queens, princes, and princesses took parts with the courtiers; or whether it is of later growth, and derived from professional dancers upon the stage. The former is the general opinion, but an analysis of the only ballet which is known to have been printed in a complete form during the 16th century, would lead to the inference that the court entertainments of Italy and France were masques, or masks, which included declamation and song, like those of Ben Jonson with Inigo Jones for the court of James I.

The introduction of the Italian style of ballet into France was on the occasion of the marriage of the Duc de Joyeuse with Mdle. de Vandemont, sister to the queen. This was in 1581; and the ballet was printed in 1582, in a small folio of eighty-two leaves, with music, dialogue, engravings of the scene and of the fancy dresses, and full details of the plot. It is entitled *Balet Comique de la Roynne*, because the queen took a part in it, as one of the naiades, with her ladies; but they were only posed upon machinery to be looked at, and neither spoke nor sang. One lady of the court sang a song, two others a duet, and, again, others a chorus. Jupiter and Mercury each sang a song, but Circe and the rest spoke poetry. The king's musicians, as tritons, were the mainstays of the music; the ladies and gentlemen of the court appeared in splendid fancy dresses, and danced the entrées. The inventor of the ballet was Baltazarini Belgioioso, who had assumed the name of Balfassar de Beaujoyeux upon his appointment as first musician to

Catherine de Medicis, queen dowager of France. The disuse of dialogue and of vocal music in ballet seems to have been arrived at only by degrees. One of the most complete books upon the subject is by the Jesuit Le Père Menestrier (Claude François) *Des Ballets Anciens et Modernes*, 12mo, 1681. He was the inventor of a ballet for Louis XIV. in 1658; and in his book he analyses about fifty of the early Italian and French ballets. His definition is as follows:—"Ballets are dumb comedies, which should be divided into acts and scenes, like other theatrical pieces. Recitations divide them into acts, and the entrées of dancers are equal in number to the scenes." So recitation had not then been dispensed with. At length the opinion gained ground that, in stage representations, the actions, feelings, and passions could be more faithfully, gracefully, and intelligibly expressed to the eye by pantomimic action, than it would be possible to do to the ear. The art of dramatic expression then became a greater object of study; and, perhaps, from about the middle of the last century, or in the time of Noverre, the spectators have been prepared only by a short printed summary of the story which was to be represented. (w. ch.)

**BALLINA**, a seaport and market-town of Ireland, county of Mayo, 18 miles N.N.E. of Castlebar, situated on the River Moy, which is here crossed by two bridges. It has a parish and a Roman Catholic church (the latter being in the suburb of Ardnaree on the opposite side of the river), Baptist and Methodist chapels, a court-house, three branch banks, a workhouse, hospital, dispensary, barracks, and several schools. A convent was erected in 1867. The salmon fishery and fish-curing are important branches of its trade; and it has also breweries and flour-mills, and manufactures snuff and coarse linen. The amount of harbour receipts in 1873 was £1266. In 1798 Ballina was for a short time in the possession of the French, under General Humbert. In the neighbourhood there is an interesting dolmen, proved by the early annals of Ireland to belong to the 5th century A.D. (*vide* Fergusson's *Rude Stone Monuments*). To the east of the village are the remains of an abbey, with a Gothic door-case in fine preservation (Archdall). Population in 1871, 5551.

**BALLINASLOE**, a town of Ireland, province of Connaught, 91 miles W.S.W. of Dublin. The River Suck, an affluent of the Shannon, divides it into two parts; the western being in the county of Galway, the eastern in the county of Roscommon. They are connected by two bridges and a causeway across an island. The town is clean and well built, and contains a handsome church, with a singular octagonal spire springing from scrolls. There are Roman Catholic and Methodist chapels, several public schools, a district lunatic asylum, union workhouse, market-house, a savings bank (established in 1823), several flour-mills, and breweries. In the neighbourhood is Garbally Castle, the seat of the earl of Clancarty. A great annual cattle fair is held here from the 5th to the 9th of October. Its importance may be judged from the fact, that in 1874 there were exposed for sale 18,018 horned cattle and 65,130 sheep. The *Western Star* is published in the town. Population in 1871, 4619.

**BALLOON**. See **AERONAUTICS**, vol. i. pp. 187-207.

**BALLOT**, or secret voting, has been employed in political, legislative, and judicial assemblies, and also in the proceedings of private clubs and corporations. At Athens, the dicasts, in giving their verdict, generally used balls of stone (*psophi*) or of metal (*spondulii*). Those pierced in the centre, or black in colour, signified condemnation; those unpierced, or white, signified acquittal. The boxes were variously arranged; but generally a brass box received both classes of votes, and a wooden box received the unused balls. In the assembly, cases of *privilegia*, such as ostracism,

the naturalisation of foreigners, or the release of state-lettons, were decided by secret voting. The petalism, or voting by words on olive-leaves, practised at Syracuse, may also be mentioned. At Rome the ballot was introduced to the comitia by the *Leges Tabellariae*, of which the *Lex Gabiana* (139 B.C.) relates to the election of magistrates, the *Lex Casia* (137 B.C.) to *judicia populi*, and the *Lex Papiria* (131 B.C.) to the enactment and repeal of laws. The wooden *tabellae*, placed in the *cista*, or wicker box, were marked U. R. (*uti rogat*) and A. (*antiquo*) in the case of a proposed law; L. (*libero*) and D. (*damno*) in the case of a public trial; in the case of an election, *puncta* were made opposite the names or initials of the candidates. *Tabellae* were also used by the Roman judges, who expressed their verdict or judgment by the letters A. (*absolvo*), C. (*condemno*), and N. L. (*non liquet*).<sup>1</sup>

In Great Britain the ballot was suggested for use in Parliament by a political tract of the time of Charles II. It was actually used by the Scots Parliament of 1662 in proceeding on the "Billeting Act," a measure proposed by Middleton to secure the ostracism of Lauderdale and other political opponents who were by secret vote declared incapable of public office. The plan followed was this: each member of Parliament wrote, in a disguised hand, on a piece of paper, the names of twelve suspected persons; the billets were put in a bag held by the registrar; the bag was then sealed, and was afterwards opened and its contents ascertained in the Exchequer Chamber, where the billets were immediately burned, and the names of the ostracised concealed on oath. The Billeting Act was repudiated by the king, and the ballot was not again heard of till 1705, when Fletcher of Saltoun, in his measure for a provisional government of Scotland by annual Parliaments in the event of Queen Anne's death, proposed secret voting to protect members from court influence. The gradual emancipation of the British Parliament from the power of the Crown, and the adoption of a strictly representative system of election, have not only destroyed whatever reason may once have existed for the ballot in deliberative voting, but have rendered it essential that such voting should be open. It was in the agitations for parliamentary reform at the beginning of the 19th century that the demand for the ballot in parliamentary elections was first seriously made. The Benthamites advocated the system in 1817.<sup>2</sup> At the Peterloo Massacre (1819) several banners were inscribed with the ballot. O'Connell introduced a bill on the subject in 1830; and the original draft of Lord John Russell's Reform Bill, probably on the suggestion of Lords Durham and Duncannon, provided for its introduction. Later on Mr Grote became its chief supporter in the House of Commons; and from 1833 to 1839, in spite of the ridicule cast by Sydney Smith on the "mouse-trap," and on Mr Grote's "dagger-box, in which you stab the card of your favourite candidate with a dagger," the minority for the ballot increased from 106 to 217. In 1838 the ballot was the fourth point of the People's Charter. In the same year the abolition of the land qualification introduced rich commercial candidates to the constituencies. Lord Melbourne's cabinet declared the question open. The cause, upheld by Macaulay, Ward, Hume (in his resolutions, 1848), and Berkeley, was strengthened by the Report of Lord Hartington's Select Committee (15th March 1870),<sup>3</sup> to the effect that corruption, treating, and intimidation by priests and landlords took place to a large

extent at both parliamentary and municipal elections in England and Ireland; and that the ballot, if adopted, would probably not only promote tranquillity at elections, but protect voters from undue influence, and introduce greater freedom and purity in voting, provided secrecy was made inviolable except in cases where a voter was found guilty of bribery, or where an invalid vote had been given. At Manchester and Stafford in 1869, test ballots had taken place on the Australian principle as practised in Victoria.—the voting card containing the names of all the candidates, printed in different colours (for the benefit of illiterate voters), and the voter being directed to score out the names of those he did not support, and then to place the card (covered by an official envelope) in the box. It was found at Manchester, that the voting was considerably more rapid, and therefore less expensive, than under the old system; that only 80 cards out of 11,475 were rejected as informal; and that, the representatives of candidates being present to check false statements of identity, and the public outside being debarred from receiving information what voters had voted, the ballot rather decreased the risk of personation. At Manchester the cards were not numbered consecutively, as is done in Victoria, so that (assuming the officials to be free from corruption) no scrutiny could have detected by whom particular votes were given. At Stafford the returning officer stamped each card before giving it to the voter, the die of the stamp having been finished only on the morning of the election. By this means the possibility was excluded of what was known in the colonies as "the Tasmanian Dodge," by which a corrupt voter gave to the returning officer, or placed in the box, a blank non-official ticket, and carried out from the booth his official card, which a corrupt agent then marked for his candidate and gave, so marked, to corrupt voter No. 2 (before he entered the booth), on condition that he also would bring out his official card, and so on *ad libitum*; the agent thus obtaining a security for his bribe, unless the corrupt voter chose to disfranchise himself by making further marks on the card.

At the close of 1870 the ballot was employed in the election of members for the London School Board, under the Education Act of that year.

In 1872 Mr Foster's Ballot Act (35 and 36 Vict. c. 33) introduced the ballot in all parliamentary and municipal elections; except parliamentary elections for universities; and the code of procedure prescribed by the Act was adopted by the Scotch Education Board in the first School Board election (1873), under "The Education (Scotland) Act, 1872." It is impossible here to analyse the Ballot Act, which not only abolishes public nominations of candidates, but deals with the offence of personation and the expenses of elections. As regards the ballot, a white paper is used on which the names of the candidates are printed in alphabetical order, the voter filling up with a X the blank on the right hand opposite the name he votes for. The paper, before being given out, is marked by the presiding officer on both sides with an official stamp, which is kept secret, and cannot be used for a second election within seven years. The paper is marked on the back with the same number as the counterfoil of the paper which remains with the officer. This counterfoil is also marked with the voter's number on the register, so that the vote may be identified on a scrutiny; and a mark on the register shows that the voter has received a ballot paper. The voter folds up the paper so as to conceal his mark, but to show the stamp to the officer, and deposits it in the box, which is locked and sealed, and so constructed that papers cannot be withdrawn without unlocking it. Papers inadvertently spoiled by the voters may be exchanged, the officer preserving separately the spoiled papers. If a voter is incapacitated from blindness, or other physical cause, or

<sup>1</sup> In Saxony juries still vote by ballot.

<sup>2</sup> See the powerful article by James Mill, *Westminster Rev.*, vol. xiii.

<sup>3</sup> For a description of Mr Grote's card-frame, in which the card was punctured through a hole, and was thus never in the voter's hands, see *Speekeeer*, 25th February 1837.

<sup>4</sup> Parliamentary Papers, 1868-9, R. 352, 352-L.; and 1870, R. 115

makes before the officer a declaration of inability to read, or when the poll is on a Saturday declares himself a Jew, the officer causes the paper to be marked as the voter directs, and keeps a record of the transaction. A voter who claims to vote after another has voted in respect of the same qualification, obtains a (green) paper which is not placed in the box, but preserved apart as a "tendered" paper. He must, however, declare his identity, and that he has not already voted. The presiding officer, at the close of the poll, has to account to the returning officer for the papers entrusted to him, the number being made up by—(1) papers in the box, (2) spoiled papers, (3) unused papers, and (4) tendered papers. During the voting (for which schoolrooms and other public rooms are available, and for which a separate compartment must be provided for every 150 electors entitled to vote at a station) agents of candidates are allowed to be present in the polling-station, but they, as well as the officials, are sworn to secrecy as regards who have voted, and for whom; and they are prohibited from interfering with the voter, inducing him to show his vote, or attempting to ascertain the number on the back of the paper. These agents are also present with the returning officer when he counts the papers and the votes, rejecting those papers—(1), which want the official mark *on the back*; (2), on which votes are given for more candidates than the voter is entitled to vote for; (3), on which anything except the number on the back is marked or written by which the voter can be identified; (4), which are unmarked, or so marked that it is uncertain for whom the vote is given. The counted and rejected papers, and also the "tendered" papers, counterfoils, and marked register (which have not been opened), are, in parliamentary elections, transmitted by the returning officer to the clerk of the Crown in Chancery in England, or the sheriff-clerk in Scotland, who destroys them at the end of one year, unless otherwise directed by an order of the House of Commons, or of some court having jurisdiction in election petitions. Such petitions either simply dispute the accuracy of the return on the ground of miscounting, or wrongous rejection or wrongous admission of papers, in which case the court examines the counted and rejected papers; or make allegations of corruption, &c., on which it may be necessary to refer to the marked counterfoils and ascertain how bribed voters have voted. Since the elections of 1874 much discontent has been expressed, because judges have rejected papers with trifling (perhaps accidental) marks other than the X upon them, and because elections have been lost through the failure of the officer to stamp the papers. For this purpose the use has been suggested of a perforating instead of an embossing stamp, while a dark ground paper with white voting-spaces would make *misplaced votes* impossible. The Ballot Act has introduced several new offences, such as forging or fraudulently defacing or destroying a paper or the official mark; supplying a paper without due authority; fraudulently putting into the box a non-official paper; fraudulently taking a paper out of the station without due authority; destroying, taking, opening, or otherwise interfering with a box or packet of papers then in use for election purposes. These offences, and attempts to commit them, are punishable in the case of officers and clerks with imprisonment for two years, with or without hard labour. In other cases the term of imprisonment is six months.

The ballot being thus *en fait accompli* in the United Kingdom, it is now scarcely necessary to indicate the arguments by which it was supported and opposed. It has been found possible to render voting perfectly secret and to provide for a scrutiny. It would be foolish to expect that secret voting will be a perfect security for independent voting. Bribery, treating, and intimidation continue to

be practised, but with diminished effect. Bribery may still be made conditional on the briber's success, but the Act is felt to be an expression of national opinion against all interference with individual judgment. The argument that the franchise is a public trust, to the exercise of which a public responsibility should attach, would be conclusive if the "selfish partialities" of the voter were the chief evil. The ballot was declared to lead to universal hypocrisy and deception; and Sydney Smith spoke of "voters, in dominos, going to the poll in sedan-chairs with closely-drawn curtains." The observed effect of a secret ballot is, however, gradually to exterminate undue influence and canvassing; and when the necessity for secrecy is removed, votes are not kept secret. The alarm of "the Confessional" seems to be unfounded, as a Catholic penitent is not bound to confess his vote, and if he did so, it would be a crime in the confessor to divulge it.

The ballot is used very largely in the British Colonies, and on the Continent. In South Australia, under the Constitution Act of 1856 and the Electoral Act of 1858, both the Legislative Council and the House of Assembly are elected by manhood suffrage under the ballot, the returning officer *putting his initials* on the voting card, which the voter is directed, under pain of nullity, to fold so that the officer may not see the vote which is indicated by a cross. The cards are destroyed when the poll is announced; and thus personation, though proved against certain voters for the purpose of punishing them, would not void an election, for there can be no scrutiny before the Court of Disputed Returns. Canvassing has almost disappeared. In Victoria, under the Electoral Act of 1865 (29 Vict. c. 279), both the Legislative Council and the Legislative Assembly are elected practically by manhood suffrage under the ballot, which was introduced in 1856. The officer adds to his initials a number corresponding to the voter's number on the register, and the cards are preserved till after the time for petitioning the Committee of Elections and Qualifications has expired, so that a scrutiny may take place of challenged votes. The important Road Boards under the Local Government Consolidation Act of 1869 are also elected by ballot. In Tasmania the chief peculiarity is that (as in South Australia) the card is not put directly by the voter into the box, but handed to the officer who puts it there (this being thought a security against double voting or voting with a non-official card, and also against the voter carrying away his card); here also the cards are destroyed immediately, while in New South Wales, where, as in Victoria, the voting is by scoring out and not by a cross, the cards are kept for five years. The vigorous municipal boards of these colonies are also elected by ballot, which has diminished expense and undue influence very greatly, but has not produced complete secrecy of voting.

In France, where from 1840 to 1845 the ballot, or *scrutin*, had been used for deliberative voting in the Chamber of Deputies, its use in elections to the Corps Législatif was carefully regulated at the beginning of the Second Empire by the Organic Decree of 2d February 1852. Under this law the voting was superintended by a bureau consisting of the deputy returning officer (called president of the section), four unpaid assessors selected from the constituency, and a secretary. Each voter presents a polling card, with his designation, date of birth, and *signature* (to secure identity), which he has previously got at the *Mairie*. This the president mutilates, and the vote is then recorded by a "bulletin," which is not official, but is generally printed with a candidate's name, and given to the voter by an agent outside, the only conditions being that the bulletin shall be "*sur papier blanc, sans signes extérieurs, et préparé en dehors de l'assemblée.*" The

total number of votes given (there being only one member in each electoral district) is checked by reference to "la feuille d'appel et inscription des votants," the law still supposing that each voter is publicly called on to vote. If the voter, when challenged, cannot sign his polling card, he may call a witness to sign for him. The following classes of bulletins are rejected:—"illisibles, blancs, ne contenant pas une désignation suffisante; sur lesquels les votants se sont fait connaître; contenant le nom d'une personne n'ayant pas prêté le serment prescrit" (i.e., of a person not nominated). Only the votes pronounced bad by the bureau in presence of representative scrutineers are preserved, in case these should be called for during the "Session pour vérification des Pouvoirs." Practically the French ballot did not afford secrecy, for you might observe what bulletin the voter took from the agent, and follow him up the *queue* into the polling-place; but the determined voter might conceal his vote even from the undue influence of Government by scratching out the printed matter and writing his vote. This was always a good vote, and scrutiny of good votes was impossible. The ballot is still used in the elections to the National Assembly, but in the Assembly itself only in special cases, as, e.g., in the election of a "rapporteur." Under the law of 10th August 1871, the conseils généraux (departmental councils) are elected by ballot. In Piedmont the ballot formed part of the free constitutional government introduced by Charles Albert in March 1848; it was extended to Italy in 1861. Voting for the Italian Chamber of Deputies takes place under the law of 20th November 1859, and in public halls (not booths), to which admission is gained by showing a certificate of inscription, issued by the mayor to each qualified voter. A stamped blue official paper, with a memorandum of the law printed on the back (*bolletino spiegato*), is then issued to the elector; on this he writes the name of a candidate (there being equal electoral colleges), or, in certain exceptional cases, gets a confidential friend to do so, and hands the paper folded up to the president of the bureau, who puts it in the box (*urna*), and who afterwards presides at the public "squinio dei suffragi." No scrutiny is possible; canvassing and bribery are rare; and Cavour thought the ballot had quite nullified the clerical power, at least in Piedmont. Greece is the only European country in which the ball ballot is used. The voting takes place in the churches, each candidate has a box, on which his name is inscribed, one half (white) being also marked "Yes," the other half (black) "No." The voter, his citizenship or right to vote in the eparchy being verified, receives one ball or leaden bullet for each candidate from a wooden bowl, which a clerk carries from box to box. The voter stretches his arm down a funnel, and drops the ball into the "Yes" or "No" division. The vote is secret, but there is apparently no check on "Yes" votes being given for *all the candidates*, and the ball or bullet is imitable. In the United States a most imperfect ballot system prevails. In many states there is no register, and therefore personation and double voting are practised. Again, there is no official card, but, as in the Shanty system of New York, candidates' touts give out printed and designed cards, which sometimes fraudulently imitate one another in design, so that ignorant voters are misled. Again, the ballot is generally taken in an engine-house, or shed open to the street, so that mob-intimidation may be used, and votes, as in France, are not practically secret. In Massachusetts, in 1851-2, the Know-nothing or Anti-Irish party, anxious to prevent personation, introduced a secret ballot for state elections, using the Manchester envelope and an official card, with the names of the candidates printed. This led to fraud and was abandoned, a return being made to the French system.

The history of the ballot in Hungary is remarkable. Before 1848 secret voting was unknown there. The electoral law of that year left the regulation of parliamentary elections to the county and town councils, very few of which adopted the ballot. The mode of voting was perhaps the most primitive on record. Each candidate had a large box with his name superscribed, and painted in a distinguishing colour. On entering the room alone the voter received a rod from 4 to 6 feet in length (to prevent concealment of non-official rods on the voter's person), which he placed in the box through a slit in the lid. By the electoral law of 1874,<sup>1</sup> the ballot in parliamentary elections in Hungary is abolished, but is made obligatory in the elections of town and county councils, where votes are given for *several persons at once*.<sup>2</sup> This voting, however, carried on by party-lists on differently coloured cards is practically open. There is a strong feeling in Hungary that the ballot would be worked by the Catholic clergy through the Confessional. As most of the electors are freeholders, there is little intimidation. In Prussia, Stein, by his *Städteordnung*, or Municipal Corporation Act of 1808, introduced the ballot in the election of the Municipal Assembly (*Stadtverordneten Versammlung*). Under the German Constitution of 1867, and the New Constitution of 1st January 1871, the elections for the Reichstag are conducted by universal suffrage under the ballot in conformity with the Electoral Law of 31st May 1869, which also divided Germany into equal electoral districts.

To secure complete secrecy, and to avoid the possibility of fraud and the large expense of printing and counting ballot papers, several ballot machines or registers have been invented. In that of Vassie there was an arrangement of confluent funnels, by which the voter was prevented from dropping more than one ball into the box. In that of Chamberlain the number of votes given was indicated by the ringing of a bell. In that of Sydsaerff,<sup>3</sup> the ball was placed by the sheriff in the common duct, and the voter, by moving a lever, guided it into a channel leading to the box of a particular candidate. Generally, it may be said that these mechanical contrivances have been attempts to make the ball-system secret and accurate, each voter depositing a ball, and the accumulated balls showing the state of the poll. This in a large constituency would become unwieldy, and no permanent record of the poll (except the collocation of the balls) would be obtained. A considerable advance is made in the invention of Mr James Davie, Edinburgh, which we select for detailed description. Of this register an essential part is the wooden chamber (4 feet square by 7 feet in height) which the voter, having received a metal ball from the sheriff, enters by a spring-hinged door to which a lever is attached. On one side of the chamber is a box, on the lid of which stand differently coloured cups, marked each with a number and the name of a candidate. Inside the box is a cylinder traversed lengthwise by a spindle, and having at one end a toothed wheel. By a screw-nut the cylinder revolves on and moves along the spindle. On the cylinder is paper divided into spaces, which correspond with the cups, and above this a sheet of carbonised paper as a printing medium. A pinion connects the cylinder with the door-lever, so that the opening of the door drives round the paper one space. A steel type, suspended on an elastic card, is centred to each cup. The voter having placed the ball in a cup, leaves the chamber by another spring-hinged door, which in opening displaces

<sup>1</sup> Hungary is now being divided into equal electoral districts.

<sup>2</sup> On the other hand, by the 21<sup>st</sup> of the original bye-laws of the Bank of England, it was provided that the ballot should be used in the general courts "if any question concerning only one person, matter, or thing."

<sup>3</sup> Letters-Patent, No. 63 of 1869.

the bottoms of the cups, and thus causes the ball to drop on the head of the type, beneath which it presses against the recording sheet on the cylinder. The ball immediately rolls down a groove to the sheriff's desk outside the chamber, where it is handed to the next voter, *only one ball being used* in connection with each register (unless, of course, there are more votes than one to be given). The closing of the exit door restores the bottoms to the cups. This simple and effectual plan has the merit of secrecy, of immediate detection of fraud (e.g., the introduction of a non-official ball to the cup), of rapidity in voting and in counting, and of leaving almost nothing to the voter's presence of mind. The voter can make only one well-defined mark on the paper, and this he can do only in leaving the chamber before the next voter has entered. Mr Davie's invention, which in 1870 received a prize from the Royal Scottish Society of Arts, is obviously not adapted to cumulative voting, but may be worked with any number of candidates under single voting. Although the motion of the cylinder would record in a diagonal direction the series of votes, it would be practically impossible to identify votes from a numbered list of the voters. (w. c. a.)

**BALLYCASTLE**, a seaport town of Ireland, county Antrim, situated on a bay opposite Rathlin island. The town is well built, consisting of two parts, about a quarter of a mile asunder, and connected by a fine avenue. Towards the close of the 18th century, one of the Boyd family devoted himself to the extension and improvement of the town, establishing manufactures, endowing charities, and building churches, and succeeded in producing a temporary vitality. Upwards of £150,000 is said to have been expended upon the pier and harbour; but the violence of the sea overthrew the former, and the latter has been filled with sand. To the east of the town are the remains of an abbey. Population in 1871, 1253.

**BALLYMENA**, a town of Ireland, county Antrim, on the Braid, an affluent of the Maine, two miles above their junction. It is 33 miles N.N.W. of Belfast, with which it is connected by railway. The town owes its prosperity chiefly to its linen trade, introduced in 1733, which gives employment to the greater part of the inhabitants. It has a parish church, several chapels and schools, a market-house, and four branch banks. There is a newspaper published in the town called the *Ballymena Observer*. Population in 1871, including Hanyville in the suburbs, 7931.

**BALLYSHANNON**, a seaport and market-town of Ireland, county of Donegal, situated at the mouth of the Erne. Lat. 54° 30' N., long. 8° 11' W. The river is here crossed by a bridge of fourteen arches, which connects the town with the suburb of Furt. Below the bridge the river forms a beautiful cascade, 150 yards wide, with a fall at low water of 16 feet. The harbour is a small creek of Donegal Bay, about 600 yards long and 350 yards broad, and is only accessible to small vessels. The town contains a church, several chapels, a bank, a market-house, barracks, and a union workhouse. The salmon fishery is the only important occupation. Previous to the Union Ballyshannon returned two members to the Irish Parliament. Population in 1871, 2958.

**BALMEZ**, JAIMES LUCIEN, a Spanish ecclesiastic, eminent as a political writer and a philosopher, was born at Vich in Catalonia, on the 28th August 1810, and died there on the 9th July 1848. The most important of his works, and that on which his fame principally rests, is entitled *El Protestantismo comparado con el Catolicismo en sus relaciones con la Civilizacion Europea*, published 1842-44, a most able defence of Catholicism. It has been translated into French, Italian, German, and English. The best of his philosophical works, which are able expositions of

the old scholastic system of thought, are the *Filosofia Fundamental*, 1846, and the *Curso de Filosofia Elemental*, 4 vols. 1847. The *Protestantism and Catholicism* and the *Fundamental Philosophy* have both been translated into English (1849, 2 vols. 1857). Nearly all the works are to be had in German and French. See M. de Blanche-Ruffin, *Jacques Balmez, sa Vie et ses Ouvrages*, Paris, 1849.

**BALMORAL CASTLE**, a residence of Her Majesty Queen Victoria, on the right bank of the River Dee, about 9 miles above Ballater and 50 miles from Aberdeen. The property, which now consists of upwards of 10,000 acres, besides a large tract of hill ground, belonged in its original extent to the Farquharsons of Inverey, by whom it was sold to the Earl of Fife. In 1848 it was leased by the late Prince Consort, and in 1852 was finally purchased for a sum of £32,000. The castle, which was erected at Prince Albert's private expense, is of the Scotch baronial style of architecture.

**BALNAVES**, HENRY, a Scottish Protestant, born at Kirkcaldy in Fife, in the reign of James V., and educated at the university of St Andrews. There is some doubt both as to the exact date of his birth, which has been fixed as 1520, and as to the rank in society to which he belonged. He completed his studies on the Continent, and, returning to Scotland, entered the family of the Earl of Arran, who at that time was regent; but in the year 1543 the earl dismissed him for embracing the Protestant religion. In 1546 he was implicated in the murder of Cardinal Beaton, at least he is known to have taken refuge with the conspirators in the castle of St Andrews; and when they were at last obliged to surrender to the French, he was sent with the rest of the garrison as a prisoner to France. During his confinement at Rouen he wrote the work entitled *Confession of Faith*, to which Knox added marginal notes and a preface; but it was not published till 1584, five years after his death. He returned to Scotland about the year 1559, and having joined the Congregation, was appointed one of the commissioners to treat with the duke of Norfolk on the part of Queen Elizabeth. In 1563 he was made one of the lords of Session, an office which he is said to have held for the first time in 1538, and was appointed by the General Assembly, with other learned men, to revise the *Book of Discipline*. Knox, his contemporary and fellow-labourer, gives him the character of a very learned and pious man. Balnaves died at Edinburgh in 1579.

**BALSAM**, an oleo-resin or natural compound of resin and essential oil, in such proportions that the substance is in a viscous or semi-fluid condition. The gradations from a solid resin to a limpid essential oil are insensible, and most resins have a balsamic consistency on their exudation, only hardening by exposure to air. It has been proposed to limit the name balsam to such substances as contain cinnamic or an analogous acid in addition to the volatile oil and resin which turpentine contains alone; but this distinction has not been carried out.

The fragrant balsams which contain cinnamic or benzoic acid may, however, be regarded as a distinct class, allied to each other by their composition, properties, and uses. Those of this class found in commerce are the balsam of Peru, balsam of Tolu, liquid storax, and liquidambar. *Balsam of Peru* is the produce of a lofty leguminous tree, *Myrospermum peruvianum*, growing within a limited area in San Salvador, Central America, but now introduced into Ceylon. It is a thick, viscid oleo-resin of a deep brown or black colour and a fragrant balsamic odour. It has been analysed by Kachler, who thus states its percentage composition,—cinnamic acid 46, resin 33, benzylic alcohol 20. It is used in perfumery, and in medicine as a stimulant application to indolent sores, as well as internally for



asthma and pectoral complaints. *Balsam of Tolu* is likewise produced from a species of *Myrospermum*, *M. toluiferum*. It is of a brown colour, thicker than Peru balsam, and attains a considerable degree of solidity on keeping. It also is a product of equatorial America, but is found over a much wider area than is the balsam of Peru. Tolu balsam consists of a combination of inodorous resin with cinnamic acid, no benzoic acid being present in it. It is used in perfumery and as a constituent in cough syrups and lozenges. *Liquid storax* is a balsam yielded by *Liquidambar orientalis*, a native of Asia Minor. It is a soft resinous substance, with a pleasing balsamic odour, especially after it has been kept for some time. It contains a principle—styröl or cinnamene—to which it owes its peculiar odour, besides cinnamic acid, stryacin, and a resin. Liquid storax is used in medicine as an external application in skin diseases, and internally as an expectorant. An analogous substance is derived from *Liquidambar Altingia* in Java. *Liquidambar balsam* is derived from *Liquidambar styraciflua*, a tree found in the United States and Mexico. It contains cinnamic acid, but is destitute of benzoic acid.

Of balsams entirely destitute of cinnamic and benzoic constituents the following are found in commerce:—*Mecca Balsam* or *Balm of Gilead*, yielded by the *Balsamodendron Perryi* (*B. gilodense* of De Candolle), a tree growing in Arabia and Abyssinia, is supposed to be the balm of Scripture and the *Βάλσαμον* of Theophrastus. When fresh it is a viscid fluid, with a penetrating odour, but it solidifies with age. It was regarded with the utmost esteem among the nations of antiquity, and to the present day it is peculiarly prized among the people of the East. *Balsam of Copaiba* or *Copaia* is a fluid oleo-resin of a pale brown or straw colour, produced from several trees of the genus *Copaifera*, growing in tropical America. It possesses a peculiar odour and a nauseous persistent tarry taste. Balsam of copaiba contains from 40 to 60 per cent. of essential oil, holding in solution a resin from which capivic acid can be prepared. It is chiefly used in medicine for the treatment of inflammatory affections of mucous surfaces. Under the name of *Wood Oil*, or *Gujun Balsam*, an oleo-resin is procured in India and the Eastern Archipelago from several species of *Dipterocarpus*, chiefly *D. turbinatus*, which has the odour and properties of copaiba, and is used for it in East Indian hospital practices. Wood oil is also used as a varnish in India, and forms an effective protection against the attacks of white ants. A substitute for copaiba is also found in the dark red balsam yielded by *Hardwickia pinnata*, a leguminous tree.

*Canada Balsam*.—The oleo-resins obtained from coniferous trees are usually termed turpentine, but that yielded by *Abies balsamea* is known in commerce as Balsam of Canada. It is a very transparent substance, somewhat fluid when first run, but thickening considerably with age, possessed of a delicate yellow colour, and a mild terrebithinous odour. According to Flückiger and Hanbury it contains 24 per cent of essential oil, 60 per cent. of resin soluble in alcohol, and 16 per cent. of resin soluble only in ether. It has been used for the same purposes as copaiba, but its chief uses are for mounting preparations for the microscope and as a varnish.

**BALTA**, the chief town of a circle of the same name in the Russian government of Podolia. It stands on the Kodima, near its junction with the Bug, and carries on a large trade in cattle and horses and the raw products of the surrounding district. It has two great annual fairs, the more important being held at Whitsuntide and the other in June. A variety of industries, such as tallow-melting, soap-boiling, tile-making, and brewing are likewise prosecuted. The Jews form a very considerable part of the

population, which in 1867 numbered 14,528. Balta was in great part destroyed by the Russians in 1780.

**BALTARD**, LOUIS PIERRE, a distinguished French architect and engraver, was born at Paris in 1765, and died in 1846. He was originally a landscape painter, but in his travels through Italy was so much struck with the beauty of the Italian buildings, that he changed his profession and devoted himself to architecture. In his new occupation he achieved great success, and was selected to prepare the plans for some of the largest public edifices in Paris. His reputation, however, rests not so much on his practical performances in architecture as on his great skill in the art of engraving. Among the best known of his plates are the drawings of Paris (*Paris et ses Monuments*, 2 vols. fol., 1803), the engravings for Denon's *Égypte*, the illustrations of Napoleon's wars (*Les Colonnes de la grande Armée*), and those contained in the series entitled the *Grand Prix de l'Architecture*, which for some time he carried on alone. He has also gained distinction as an engraver of portraits.

**BALTIC SEA**. The name by which this inland sea is commonly designated is first found in the 11th century, in the work of Adam of Bremen, entitled *Chorographia Scandi-*



Sketch Map of Baltic Sea.

*navie*. The derivation of the word is uncertain. It seems probable that whatever may be the etymology of the name *Baltic*, that of the Great and Little Belts is the same. The Swedes, Danes, and Germans call it the *Ostsee* or East Sea.

The Baltic is enclosed by Sweden, Russia, the German empire, and Denmark; and it communicates with the North Sea, by the winding channel which lies between the southern part of the Scandinavian peninsula and the northern peninsula of Schleswig and Jutland. The first part of this channel is in great measure blocked by the islands of Zealand and Funen, so as to form the three narrow passages which are known as the Sound (between

Sweden and Zealand), the Great Belt (between Zealand and Fünen), and the Little Belt (between Fünen and Jutland). Each of these forms a distinct communication between the Baltic and the Cattegat, which is the open portion of the channel lying between the coast of Sweden and the eastern side of Jutland; while the Cattegat opens freely into the Skager Rack, which is the continuation of same open channel, between the southern end of Norway and the north-west coast of Jutland, into the North Sea.

The length of the Baltic Sea, from Swinemünde in the S. to Tornea in the N., is nearly 900 miles; and its greatest width, between Karlsrona and Memel, exceeds 300 miles. Its whole area, including the Gulfs of Bothnia and Finland, is about 160,000 geographical square miles. It runs first in an easterly direction as far as Memel, a distance of 300 miles, and then northwards as far as lat. 59° 21' N., a distance of 350 miles, at which point it separates into two great gulfs. One of these, the Gulf of Finland, runs nearly due E.; the other, the Gulf of Bothnia, almost N. The Gulf of Bothnia is 400 miles in length, with an extreme breadth of 120 miles, but where narrowest it does not exceed 40 miles. The archipelago of Aland lies at its entrance. The Gulf of Finland is 280 miles in length, with a mean breadth of 60 or 70 miles.

The depth of the Baltic rarely exceeds 100 fathoms—being greatest between the island of Bornholm and the coast of Sweden, where it reaches 115 fathoms, and least in the neighbourhood of the mouths of large rivers, which bring down a great quantity of earthy matter, especially in the spring, so that in many parts the bottom is being so rapidly raised by its deposit that the mouths of rivers formerly navigable are now inaccessible. This is especially the case in the northern part of the Gulf of Bothnia, above Quarken, where several tracts are now dry land which were once water; and also in the neighbourhood of Tornea, where meadows now take the place of waters which were traversed in boats by the French Academicians, when they were measuring an arc of the meridian. Along the southern coast the shallowness of the harbours is a great obstacle to navigation, especially since they are closed by ice for nearly one-third of the year. On the western side it is not more than 15 fathoms deep; and, in general, it is only from 8 to 10 fathoms. On the S. it nowhere exceeds 60 fathoms. The Gulf of Finland suddenly shallows from 50 or 60 fathoms to 5, or even less. The average depth of the Gulf of Bothnia is not greater than that of the rest of the sea. Numerous rocky islands and reefs, many of them level with the water, render the navigation of this sea extremely dangerous.

The shore of the Baltic is generally low. Along the southern coast it is for the most part sandy,—with sand-banks outside, and sand-hills and plains inland. Where streams come down, there are often fresh-water lakes termed *haffs*, which are separated from the sea by narrow spits called *nehrunge*. Two of these *haffs* are of great extent; one of them, termed the Frische Haff, lies between Danzig and Königsberg, which last town is situated on the part of it most remote from the sea; the other, termed the Kurische Haff, lies between Königsberg and Memel, the latter town being situated on the channel connecting the haff with the sea. Near the entrance to the Gulf of Finland the coast becomes rocky, and continues to be so for the most part around the gulfs both of Finland and Bothnia, except towards the head of each; the rocks, however, are never high. The shores of the southern part of the Swedish peninsula are mostly high, but not rocky; at Stockholm, however, there is an archipelago of rocky islands, on some of which the town is partly built.

*Drainage Area.*—The Baltic may be considered as the estuary of a great number of rivers, none of them individu-

ally of great size, but collectively draining a very large area, which is estimated at about 717,000 square miles, or nearly one-fifth of the entire area of Europe. This great drainage area is remarkable for the small proportion of its boundary that is formed by mountains or high table-lands,—its greater part consisting of land of no considerable elevation, which slopes down very gradually to its coast-line, and of which a large proportion is covered by lakes. This is especially the character of the drainage area of the Neva, whose waters are immediately derived from the large shallow Lake Ladoga, which receives the contributions of numerous other lakes, Onega being the largest, though Lake Saima in Finland, with its irregular prolongations, is scarcely less extensive. The entire surface drained by the Neva is estimated at about 100,000 square miles, or nearly twenty times that of the drainage area of the Thames. Through Lake Onega, the Neva is connected with the Dwina and the Volga by canals, through which small vessels can pass from the Baltic into either the White Sea or the Caspian. The Duna or South Dwina, which discharges itself into the Gulf of Riga, is another important river, draining an area of about 35,000 miles in West Russia, and having a length of 520 miles, of which 405 miles are navigable. The drainage area of the Niemen, which enters the Baltic at Memel, is continuous with that of the Duna, and is of about the same extent; this river is navigable for more than 400 miles from its outlet, and communicates with the Dnieper by a canal through which vessels can pass from the Baltic to the Black Sea. The Vistula, which receives the waters of the whole area of Russian and Prussian Poland, flowing past Warsaw into the Baltic at Dantzic, is a very large and important river, having a length of 520 miles, of which 430 are navigable, and a drainage area of 72,000 square miles. And the Oder, rising in the hill districts of Silesia, drains the extensive level areas of Brandenburg and Pomerania, and discharges into an estuary, that may be said to begin from Stettin, the water drawn from an area of 45,000 square miles. Numerous rivers discharge themselves into the Gulf of Bothnia, bringing down water from the mountain ranges of Sweden and Norway; but their course is comparatively short and direct, with few tributaries, so that, individually, they do not attain any great size. The drainage of the more level southern portion of Sweden is for the most part collected by the great lakes Wener, Wetter, and Mälär, of which the first pours its water into the North Sea, and the others into the Baltic. By means of a canal joining Lakes Wener and Wetter vessels can pass directly from the Cattegat into the Baltic.

*Climate.*—It is not only, however, the extent of its drainage area, but the large proportion borne by the rain and snow which fall upon that area to the amount dissipated by evaporation from its surface, that goes to swell the aggregate of fresh water poured into the basin of the Baltic; for there is probably no inhabited region of the whole globe over which so large a quantity of snow falls, in proportion to its area, as it does in the countries round this basin. They receive, direct from the Atlantic, a vast amount of moisture brought by its west and south-west winds; and even the winds which have already passed over the low plains of Jutland and Northern Germany will have parted with little of their moisture before reaching the Baltic provinces of Russia. When these vapour-laden west and south-west winds meet the cold dry east and north-east winds of Siberia, their moisture is precipitated, in summer as rain, and in winter as snow; and owing to the prevalence of a low atmospheric temperature through a large part of the year, the proportion lost by evaporation is extremely small as compared with what passes off from other inland seas. The large excess of the amount of fresh water dis-

charged into the basin, over that which passes off by evaporation from its surface, is indicated by its low salinity, which, however, varies considerably in its different parts and at different seasons of the year. The temperature of the Baltic is remarkable for its *range*, which is rather that of a terrestrial than of a marine area—this being doubtless owing in great degree to the fact that its shallowness and the low salinity of its water allow a large part of its surface to be frozen during the winter. Nearly the whole of the Gulf of Bothnia, with the land enclosing it on both sides, lies between the January isotherms of 10° and 20°—the former crossing it near its head, and the latter near its junction with the Baltic proper: and the whole of the Baltic proper, with the land enclosing it on the east, south, and west, lies between the January isotherms of 20° and 30°. On the other hand, the July isotherm of 60°, which crosses England near the parallel of 54°, passes across the Gulf of Bothnia near the Walgruud Islands, almost 9° further north; and the whole of the Baltic proper, with the Gulf of Finland and the southern part of the Gulf of Bothnia, lies between the July isotherms of 60° and 65°. Thus the range between the *mean summer* and *mean winter* temperatures, which is only about 20° in the British Islands, is about 40° over the Baltic area. The *mean annual* temperature of the Gulf of Bothnia ranges between 30° at its northern extremity and 40° at its southern, while that of the Baltic ranges from 40° at its northern boundary to about 46° at its southern.

*Formation and Transportation of Ice.*—The greater part of the Gulfs of Bothnia and Finland is usually frozen over during the winter, the formation of ice beginning at the head and extending downwards. Masses of ice, conveyed by the currents into the Baltic proper, freeze together as the winter advances, and form vast fields, generally extending on the east side as far south as the islands of Dagö and Oesel, and on the west to the south of Stockholm. It happens sometimes, though rarely, that large portions of the Baltic proper are continuously frozen over; but navigation is usually interrupted by the blocking up of its bays and harbours with ice, from the latter part of December to the beginning of April. The freezing of the Gulfs of Bothnia and Finland begins earlier and ends later.

The curious phenomenon of the *formation of bottom-ice*, and its rise to the surface, is more frequently seen in the Baltic and the Cattagat than in the open ocean,—chiefly, it seems probable, on account of the shallowness of these seas. It has been particularly observed by Prof. Nilsson in the Cattagat, off Kullen Point, near the southern extremity of Sweden; but according to Chydenius it is very common in various parts of the Baltic, having been especially noticed by the fishermen off the Åland Islands. In calm winter weather, water of from 4 to 8 feet deep is often covered in a very short time with small plates of ice, mostly circular in form, varying in diameter from 1 to 5 inches, and having a uniform thickness which never exceeds two lines. These plates can be seen coming up from below, rising edgewise towards the surface, often with such force as to lift themselves three or four inches out of the water. When they come up in great numbers they are often piled one upon another, and are then usually soon broken, by the action either of waves or of currents, into small pieces, which unite again by regelation so as to form irregular cakes of ice; and these, as soon as the water becomes tolerably still, cohere into a continuous rough sheet. But it sometimes happens that if the plates come up more sparsely, and the weather is very still and cold, they remain unbroken, and the diameter of each increases, sometimes to two feet or even more. When the fishermen notice these ice-plates coming up from below in large quantities, they at once make for land, as they know that they might otherwise be soon com-

pletely ice-bound. The same thing appears to happen in polar seas in the shallow water near land. Chydenius, who was a member of the Swedish Spitzbergen expedition in 1857, states that on one occasion the surface of the sea, which was previously quite clear of ice, became so covered in the course of half an hour, that it was with difficulty that a boat could be forced through it; and this although the temperature of the air during the day had not been lower than 4° C., and no wind or stream had brought the ice together.

It does not seem very clear in what way this formation of bottom-ice is to be accounted for. Bottom-ice has often been noticed in fresh-water lakes and streams; and large plates have been seen to rise to the surface, sometimes with force enough to bring up stones of considerable size,—in one instance a heavy iron chain. In these cases it would seem that the motion of the bottom-water over roughened surfaces contributes to its congelation. And in the shallow water near the sea-shore, stones and sea-weeds may be seen covered with ice, like the hoar-frost on trees, before any ice forms on the surface. It is to be remembered that sea-water increases in density down to its freezing point, so that the water cooled at the surface will always go down, the deepest stratum being thus the coldest. And thus, although no lower temperature can be carried down by the water than that to which it has been subjected at the surface, the water that does not freeze at (say) -2°·5 C. when lying upon water, changes into ice when it comes in contact with the irregular solid bottom, perhaps on account of the more ready dissipation, under the latter circumstances, of the heat set free in the act of congelation.

When ice forms over the shallow bottoms which border parts of the Gulfs of Bothnia and Finland, large blocks of stone are frequently frozen into it; and these, being lifted when the water rises in the early summer, are often transported by currents to considerable distances, finally subsiding again to the bottom when the ice melts. In this manner a deposit of rocky fragments, some of them 6 or 8 feet across, is being formed at the bottom of the Baltic outlets; as is known from the fact, that sunken ships which have been visited by divers in the Sound and in Copenhagen roads have been found covered with such blocks within no very long period. It not unfrequently happens, moreover, that sheets of ice with included boulders are driven up on the coast during storms, and are thus carried some way inland, being sometimes packed to a height of even 50 feet. A case was described by Von Baer in which a block of granite, whose weight was estimated at between 400 and 500 tons, was thus carried by the ice during the winters of 1837-8; and Forchhammer mentions that the Sound being suddenly frozen over during an intense frost in February 1844, sheets of ice driven by a storm were heaped upon the shore of the bay of Täärbeijk, and frozen into one mass so as to form a mound more than 16 feet high, which threw down the walls of several houses, and left behind it ridges of sand and pebbles when it thawed. It is apparently, moreover, by similar agencies, that the fringe of rocky islands of all dimensions called the *Skär*, which lies at a little distance from the shore of many parts of the Baltic, is being gradually modified. Boats and small vessels can sail in smooth water within this *skär*, even when the sea outside is strongly agitated; but the navigation is intricate, and the danger from sunken rocks to those not thoroughly acquainted with it is very considerable. The diminution which has been noticed from time to time in the depth of the channels, and the appearance above water of what were formerly regarded as sunken rocks or reefs, have been regarded as concurring with other evidence to prove that a general rise of land is now going on over this area. But it seems probable, from what has

now been stated, that the increase of height and dimensions which has been observed in the reefs and inlets of the skär during the last half century, may be adequately accounted for by the action of ice, which has piled up (generally on a basis of *flashed rock*) accumulations of transported *débris*.

*Rise of Land around the Baltic.*—Early in the last century the Swedish physicist Celsius (to whom we owe the invention of the centigrade scale) formed the opinion that the waters both of the Baltic and of the North Sea were gradually subsiding; and this opinion, though controverted by other authorities, was embraced by Linnaeus. It is now clear that many of the facts by which it was supported are explicable by the transporting agency of rivers and of ice, as already explained; and it was pointed out by Playfair in 1802, that even admitting the proofs on which Celsius relied, they would rather show that the land is rising, than that the water is receding. During the present century a great deal of attention has been given to this question, on account of its geological interest, by many very able observers; and the results may be briefly summarised as follows:—(1.) An elevation of the whole of Norway, from the North Cape to the Nahe, has taken place within a comparatively recent period,—as is evidenced by the numbers of raised beaches containing existing shells,<sup>1</sup> which are found at different points along the western coast, frequently at a height of 200 feet above the present sea-level, and in some spots at a height of more than 600 feet. As these beaches, where one lies above another, are not always parallel, it appears that the elevatory action did not take place equally over the whole area; and the movements were probably intermittent, with long pauses between. (2.) At various points along the coast of the Baltic and the Gulf of Bothnia, alike in Sweden and in Finland, similar collections of shells have been found, belonging to species now inhabiting the basin, and characterised by the peculiar *facies* to be presently noticed as distinguishing its molluscan fauna from that of the ocean. Such deposits have been found very far inland, and at a height of 230 feet above the sea. Hence it appears that before this upheaval took place, the Baltic must have been separated, as now, from the North Sea by the mountain ridge of Norway, although it extended over a considerably larger area of what is at present low-lying land. (3.) Notwithstanding the numerous observations which have been made with a view to ascertain whether any change of level is now going on, the question must be regarded as still undetermined. Little reliance can be placed on occasional comparisons of the height of marks made upon rocks above the sea-level, since, although there are no tides, the height of the water in the basin is subject to considerable variations, from causes to be presently explained. (4.) There is a good deal of evidence, on the other hand, that, towards the southern extremity of Sweden, there has been a *depression* of the land since the historic period. In this portion, known as Scania, no elevated beds of recent marine shells have been met with; in its seaport towns there are streets now at or even below the level of the water, which must have been above it when first built; and a large stone whose distance from the sea was measured by Linnaeus, in 1749, was found 100 feet nearer the water's edge when its distance was again measured in 1836. Near Stockholm, again, a fishing-hut, with remains of boats of very antique form and construction, was found, in 1819, at a depth of 60

<sup>1</sup> The shells found in the raised beach at Uddevalla by Mr J. Gwyn Jeffreys in 1862, were characterised by him as glacial; but they have been shown to be specifically identical with mollusca now living at Spitzbergen; and it is probable that when the water was deeper than at present along the coast of Norway, these would have ranged southwards along the cold bottom, as they do even now to a certain extent.

feet, covered over with gravel and shell-marl; and it was considered by Sir C. Lyall to be impossible to explain the position of this hut without imagining first a subsidence to the depth of more than 60 feet, and then a re-elevation. On the whole, it appears clear that oscillations of level, not uniform either in direction or in degree, have taken place in various parts of the Scandinavian peninsula within a recent period, whilst in regard to the continuance of any such changes at the present time we have no certain knowledge, though it is considered probable by many of the most distinguished *swans* both of Sweden and Norway.

*Movements of Water in the Baltic.*—There is scarcely any tidal movement in the Baltic; for though there are sensible tides in the Skager Rack, these begin to diminish in the Cattegat, and are very trifling in the Sound and Belts, averaging only about a foot at Copenhagen. There is usually a general movement of the upper waters of the Baltic towards the three channels which form its outlet, and a considerable flow of water through them. The large volume of water discharged by the rivers that empty themselves into the upper end of that gulf forms a southward current, which becomes very rapid where it narrows at Quarken (being partly blocked also by the Walgrund Islands), and again where it is obstructed by the Aland Islands, as it enters the Baltic proper. In that part of the basin the current is liable to considerable modification from prevalent winds; but it is usually very perceptible in the spring and early part of the summer, when the snows are melting. On the other hand, when an unusual continuance of north-west wind concurs with high spring-tides to drive the water of the North Sea into the outlet of the Baltic, a large body of water flows back into its basin, producing a reverse current, which is felt as far as Danzig.

There are also considerable variations in the height of the water, that seem for the most part referrible to three different conditions, which may operate separately or in combination, viz., (1), the seasonal increase and decrease of the amount of water brought down by rivers; (2), the banking-up of the outflow by opposing winds; and (3), variations in atmospheric pressure.

(1.) During the winter months the quantity of fresh water poured into the Baltic by the rivers which discharge themselves into it is greatly reduced by the freezing of their sources; and this is, of course, especially the case with those that empty themselves into the Gulf of Bothnia. Hence the general level of the surface is at its lowest at this season. With the melting of the snow in spring and early summer, however, there is an enormous increase in the quantity of fresh water poured into the basin, and the level of its surface then rises. There is always, of course, a tendency to equalisation of the level of the Baltic with that of the sea outside, by outflow or inflow currents through its three channels of communication; but the narrowness of these prevents that equalisation from being immediate, and it is often interfered with by winds. (2.) The influence of winds in banking up the water at the outlets, and even in reversing the usual currents, is very decided, as has been especially shown by the recent researches of Dr Meyer of Kiel.<sup>2</sup> The strongest and most constant surface-outflow is seen during the autumn and winter months, when there is little or no elevation of level, but when the prevalent direction of the wind is such as to drive the Baltic water towards and through the straits. When, on the other hand, the winds prevalent in the North Sea tend to drive its water into the straits, their usual out-current may be reversed; and this most frequently happens during the spring and summer months, although the excess

<sup>2</sup> *Untersuchungen über Physikalische Verhältnisse des Westlichen Theiles der Ostsee.*

water to be discharged is then at its greatest. It sometimes happens, especially about the autumnal equinox, that a N.W. gale concurs with a high tide in the Skager Rack to drive its water towards the Baltic, causing it to overflow the lower portions of some of the Danish islands. If, then, a southerly wind should carry this water onwards into the Gulf of Finland, the check which it gives to the downflow of the Neva produces disastrous inundations at St Petersburg. (3.) The influence of atmospheric pressure upon the height of the water in the Baltic is very remarkable. It had long been noticed that its level occasionally rises even as much as 3 feet without any apparent cause, and maintains itself at that height, sometimes only for a few days, but occasionally for several weeks together, and this at all seasons. Schultén, having observed that such elevations of level are preceded by a fall of the barometer, and that when the barometer rises again the water subsides, was led to recognise the dependence of these changes upon converse changes in atmospheric pressure; and this reference was confirmed by observation of the constant proportion borne by one to the other. A similar consequence of variation in atmospheric pressure has been observed in the Mediterranean (see MEDITERRANEAN); and it has also been noticed in England as a disturbing element in modifying the height of the tides.

*Salinity of Baltic Water.*—As might be expected from what has been already stated, the proportion of salt in the water of the Baltic is very much below that of oceanic water, and varies greatly at different seasons. In the Gulf of Bothnia, at the time the river-flow is greatest, the surface water is often so little salt as to be quite drinkable, its sp. gr. having been found as low as 1.001. But it is said to contain at Christmas six times as much salt as at midsummer, showing that when the river supply is at its lowest, its place is taken by a reflux of salt water from the outside ocean. In the Baltic proper there is a very decided difference in salinity between the upper and the lower stratum; the less saline water of the surface flowing towards the outlet over the more saline water beneath, just as the fresh-water current of a great river runs out to sea, even far beyond the sight of land. Thus the proportion of salt in 1000 parts of a sample of surface-water taken near Stockholm being 5.919, that of bottom-water, brought up from 120 fathoms, was 7.182; and in like manner the proportion of salt in surface-water at the entrance of the Gulf of Finland being 3.552, that of bottom-water at 30 fathoms' depth was 4.921,—the proportion of salt in North Sea water averaging 32.823 parts in 1000. Nearer the outlet the proportion of salt is greater alike in surface and in bottom-water. From the careful and systematic observations of Dr Meyer (*op. cit.*) it appears that the sp. gr. of the surface-stratum at Kiel ranges between about 1.0082 in summer and 1.0142 in winter, the latter showing somewhat above half the quantity of salt contained in ordinary sea-water. But if the direction of the prevalent winds during the autumn be such as to maintain a strong surface out-current, and consequently (as will presently appear) a very strong inward under-current, as happens in some years, the maximum of salinity will present itself at that season. The sp. gr. of the deeper stratum ranges at Kiel from 1.0145 to 1.0190; at Helsingör on the Sound from 1.0190 to 1.0220; and at Korsör on the Great Belt from 1.0180 to 1.0243; thus showing it to be principally composed of North Sea water, whose sp. gr. may be taken as 1.0264.

*Currents in the Baltic Straits.*—The results of observation of the movements of the upper and under strata of water in the Baltic Straits, strongly confirm the doctrine elsewhere enunciated (see ATLANTIC) in regard to the potency of slight differences of downward pressure in the production

or under-currents. The prevalent movement of the upper stratum in the Baltic Straits is *outward*; and this concurs with the low salinity of Baltic water to indicate that it is partly an *overflow* current, produced by the excess of river supply over loss by evaporation, which tends to raise its level. But even when this *outward* surface-current is strong, there is usually an *inward* under-current of North Sea water, carrying back into the basin of the Baltic a large proportion of the salt which would otherwise be lost to it, and the existence of this under-current, which has been abundantly established by experimental inquiries, as well as by the observations of divers, is exactly what theory would lead us to predict. For if two columns of water of the same height, but differing in specific gravity, be made to communicate with each other alike at the surface and at the bottom, the lower part of the heavier column, having a greater lateral pressure, will flow towards the lighter, thus tending to produce an elevation of level in the latter, which will rectify itself by a surface-flow in the opposite direction; and thus a vertical circulation will be maintained, as long as the causes which maintain the difference of salinity remain in operation. Now, as the salinity in the oceanic column may be regarded as practically constant, whilst the salinity of the Baltic column, though not uniform, is kept down by the influx of river-water to a much lower degree, this difference will always exist to a greater or less amount. When, however, the height of the Baltic column is so much raised—either by the excess of its fresh-water supply, or by the reversal of the surface-current by the agency of wind—that the downward pressure of its less saline water exceeds that of the more saline water of the North Sea column, the under-current will be brought to a stand, or its direction will be reversed. Thus it is that when the outward movement of the upper stratum depends rather upon the prevalent winds (as is usually the case during autumn and winter) than upon the elevation of its level within the basin, the inward under-current which supplies its place is strongest and most constant. And it is by this means, much more than by the occasional reversal of the surface-current, that salt is carried back into the Baltic,—as is proved by the close correspondence shown by Dr Meyer's observations to exist between the predominance of the inward under-current and the elevation of the sp. gr. of the surface-water of the Baltic. On the other hand, it is during the spring and summer months, when the outward movement of the upper stratum is rather an overflow-current, and the salinity of the surface-water is the lowest, that the under-current sets less strongly and less constantly inward.

*Zoology.*—The fauna of the Baltic may be regarded as that of a large estuary, having a narrow communication with the sea,—its marine inhabitants being such as can adapt themselves to considerable variations in the salinity of its water. Whales rarely enter the Baltic; but porpoises frequent the neighbourhood of the Danish islands. Seals are obtained in considerable numbers at the breaking up of the ice around Gottland and the Aland Isles. The salmon is among the most abundant fishes of the Baltic proper, ascending its rivers from April to June; and salmon-trout are caught in some of its bays. The portion of the Baltic in the neighbourhood of the Danish islands is frequented by various species of *Gadide*, which do not range further east. In the 14th and 15th centuries there was a considerable herring-fishery within the Sound and along the coast of Scania (the southern portion of Sweden); but this fish seems to have latterly quite deserted the Baltic, and rarely shows itself even in the Categat. On the eastern coast of Sweden, on the other hand, and in the Gulf of Bothnia, a fish called the *strömling*, which is nearly allied to the herring, being chiefly distinguished by its small size, is

taught in great numbers, and is dried and salted for distant markets. The molluscan fauna of the Baltic is chiefly made up of common shells of our own shores,—such as *Cardium*, *Mytilus*, and *Littorina*, which can bear an admixture of fresh water, together with several proper fresh-water shells, such as *Paludina*, *Neritina*, and *Lymnaea*; the marine types, however, being remarkable for their very small size, which is often not above one-third of their usual dimensions. There is an entire absence, except in the neighbourhood of the straits, of such essentially marine types as *Buccinum*, *Ostrea*, *Pecten*, *Patella*, and *Balanus*. It is interesting to remark that the Danish *Kjökkenmødding* contain abundance of oysters, and also of full-sized cockles, mussels, and periwinkles; from which it may be inferred that even within the human period the outside ocean had freer access to the basin of the Baltic than it has now,—probably through what is now the peninsula of Jutland, which seems at no remote period to have been an archipelago. (w. R. C.)

BALTIMORE, in Maryland, one of the largest and most flourishing cities in the United States of North America, is situated on the north side of the Patapco River or Bay, 14 miles above its entrance into the Chesapeake, 37 miles N.E. of Washington, and 100 S.W. of Philadelphia. Lat.

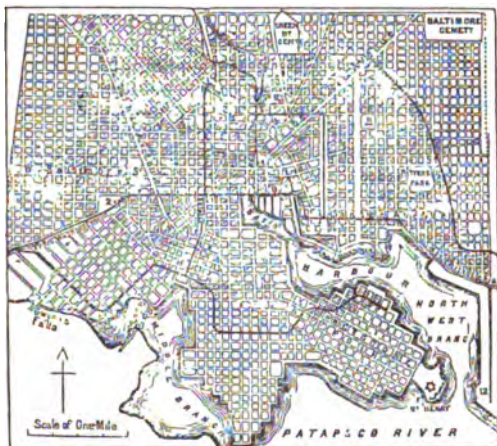

Ground-Plan of Baltimore.

- |                                      |                               |
|--------------------------------------|-------------------------------|
| 1. Northern Central Railway Station. | 7. Penitentiary.              |
| 2. Mount Clare do.                   | 8. City Hall.                 |
| 3. Camden do.                        | 9. Washington Monument.       |
| 4. St Mary's College.                | 10. Battle Monument.          |
| 5. Baltimore College.                | 11. Hospital.                 |
| 6. Prison.                           | 12. Lazaretto and Lighthouse. |

39° 17' N., long 76° 36' W. The natural advantages of this position were long overlooked by the settlers in the vicinity of the Chesapeake; and it was only in 1729 that they directed their attention to the place, and laid out a plan of the town. At that time a part of it was under cultivation as a farm, but all the rest was a wilderness. For some years its growth was by no means rapid, as it had to contend with all the obstacles that could be thrown in its way by the jealousy of older rivals. From an authentic sketch of Baltimore made in the year 1752, it appears that it then contained about twenty-five houses, only four of which were built of brick, the rest being of a more primitive structure. In 1768 it became the county town; and in 1775, according to a census then taken, it contained 564 houses, and 5934 inhabitants. From this time it rose rapidly into importance; and in 1780 became a port of entry, when a custom-house was opened. Previous to this all vessels trading to and from the port had to be entered, cleared, and registered at Annapolis. In December 1796

it obtained an act of incorporation. By the census of 1870 Baltimore contained 267,854 inhabitants.

The city is pleasantly situated on slightly undulating ground, and extends about  $4\frac{1}{2}$  miles from E. to W., and  $3\frac{1}{2}$  from N. to S., covering an area of 10,000 acres. It is divided into two nearly equal parts by a small stream called Jones's Falls, crossed by a number of bridges. The division east of the falls is nominally subdivided into two parts—Fell's Point and Old Town. The former, the most easterly part of the town, is the principal resort of seamen, and is the place where the shipbuilding and manufactures are principally carried on. The Old Town lies to the N. and W. of this. The portion west of the Falls is likewise divided into two parts, the city proper and Spring Garden. The former is the centre of trade, and the residence of the more wealthy inhabitants; while the latter, which is the extreme south-western quarter, and the lowest and most unhealthy portion of the city, is inhabited by the poorer classes. Baltimore contains about 200 churches, and has three universities, several colleges, 122 public schools, a state normal school, a manual labour school, besides numerous private schools and academies, an academy of art and science, an infirmary, hospitals, asylums, dispensaries, &c., three theatres, an opera-house, a museum, and many fine public buildings. The most imposing building in the city is the new city hall, one of the finest structures of the kind in the country. It occupies an entire square of ground, an area of about 26,000 square feet, near the centre of the city, and contains the various municipal offices. The style of architecture is the Renaissance, of which it is a fine specimen. The entire outer facing of the walls, the portico, and all the ornamental work, are of white Maryland marble; the inner walls and floors are of brick, and are fire-proof. It is four stories high, surmounted by a Mansard roof of iron and slate, with a dome and tower of iron on a marble base, rising to the height of 240 feet. The interior is very finely finished. It was begun in 1867, and cost about \$2,600,000. Another important public building is that of the Peabody Institute, founded by the late George Peabody, Esq., of London, and endowed by him to the amount of \$1,400,000. It has provisions for a public library, a gallery of art, and a conservatory of music, also for lectures and musical performances. It was incorporated in 1857. One wing of the building, which is immediately contiguous to the Washington monument, is completed, and the remainder is in progress. The completed wing is faced and ornamented with white marble, in a simple but massive and imposing style, and contains the library of over 56,000 volumes (1875), and a hall for lectures, concerts, &c. The custom-house is a spacious building, 225 feet long, by 141 feet wide. The principal room is 53 feet square, and is lighted by a dome 115 feet above the street. On its four sides are colonnades, the columns of which are each a single block of fine Italian marble. Baltimore has several splendid monuments, which have acquired for it the name of "the Monumental City." The largest of these, erected to the memory of Washington, stands on an eminence of 150 feet, and has, with its base, an altitude of 200 feet. It is of white marble; the base is 50 feet square, and 24 feet in height, surmounted by a Doric column 25 feet in diameter at the base, with a spiral staircase in its interior, and on the summit is a statue of Washington, 13 feet high. The "Battle Monument," also of white marble, was erected by public subscription in 1815, to the memory of those who had fallen in defence of the city in the previous year. It is 52 feet high; the base is of Egyptian architecture; the column is in the form of a bundle of Roman fasces, upon the bands of which are inscribed the names of those whom it commemorates; and the whole is surmounted by a female figure, the emblematical genius of the city. The city

is supplied with water from Lake Roland, an artificial lake about 8 miles north of the city, of a capacity of 500,000,000 gallons, and from three other reservoirs, with an aggregate storage capacity of about 580,000,000 gallons, the common source of supply being Jones's Falls. There are also numerous public springs and fountains throughout the town. Baltimore has a number of parks and public squares, chief of which is Druid Hill Park, a tract of 700 acres on the extreme north-west of the city, possessing more natural beauties than any other in the United States.

The manufactures and commerce of Baltimore are very extensive and flourishing. There is scarcely a branch of industry that is not prosecuted to some extent in the city or its vicinity. Among these are shipbuilding, iron and copper works, woollen and cotton manufactures, pottery, sugar-refining, petroleum-refining, distilling, saddlery, agricultural implement-making, cabinet-making, tanning, &c. In the vicinity of Baltimore is found the finest brick-clay in the world, of which more than 100,000,000 bricks are made annually. The Abbott Iron-works, in the eastern part of the city, have the largest rolling-mills in the United States. An industry peculiar to Baltimore is the packing of oysters in air-tight cans for shipment to all parts of the world. The oysters are taken in the Chesapeake Bay. Fruits and vegetables are also packed in the same way, the entire trade consuming from twenty to thirty million cans annually. This city is one of the greatest flour-markets in the Union, and has a large export trade in tobacco. There belonged to the port of Baltimore (30th November 1874) 834 vessels, registering 84,900 tons, of which 66 vessels (22,000 tons) were engaged in foreign, and the rest in the coasting trade. These figures show a considerable reduction from those of 1860, as a result of the war between the States, during which many Baltimore vessels were enrolled under foreign flags, and have so remained. There are twenty-six banks, with a capital (in 1874) of \$14,000,000, and seven savings-banks; seventeen fire and marine and three life insurance companies, besides many agencies for other companies. The assessed value of taxable property of all kinds in Baltimore for the year 1870 was \$207,181,550, and for the year 1875, \$231,242,313, being an increase of \$24,060,763. The harbour, which consists of three parts, is excellent. Its entrance, between Fort M'Henry and the lazaretto, is about 600 yards wide, with 23 feet of water. This depth is continued with an increased width for a mile and a quarter, to near Fell's Point. The entrance to the second harbour is opposite Fell's Point, where the width is contracted to one-fourth of a mile, with a depth of 16 feet. Above this entrance it widens into an ellipse of a mile long, half a mile broad, and 15 feet deep. The third, or inner harbour, has a depth of 14 feet, and penetrates to near the centre of the city. Vessels of the largest class can lie at the wharves near Fell's Point, Locust Point, and Canton, and those of 500 tons can come into the inner harbour. The harbour is defended by Fort M'Henry. The railroads of Baltimore are,—The Philadelphia, Wilmington, and Baltimore line, opened in 1837, length 98 miles; the Northern Central, to Sunbury in Pennsylvania, completed in 1858, length 138 miles; the Baltimore and Potomac to the Potomac River, opened in 1873, length 73 miles, with a branch to Washington (on this road there is a tunnel a mile and three-quarters in length); the Baltimore and Ohio, the main stem of which goes to Wheeling, a distance of 379 miles, opened through in 1853. It has the Parkersburg Division, 104 miles; the Central Ohio Division, to Columbus, 513 miles from Baltimore; and the Lake Erie Division to Chicago, opened in 1874, 878 miles. The city is also traversed by numerous lines of horse-railways for the convenience of local travel. In healthfulness Baltimore is

the fourth city in the Union, its annual death-rate being .025. Its mean annual temperature is 56° Fabr.; the mean summer and winter temperatures 76° and 36° respectively.

**BALUCHISTAN**, a maritime country of Asia, whose coast is continuous with that of the north-western part of the Indian Peninsula. It is bounded on the N. by Afghanistan, on the E. by Sindh, on the S. by the Arabian Sea, and on the W. by Persia. The frontier between Persia and Baluchistan has been drawn by an English commission, sent out in 1870 under Sir F. Goldsmid, from Gwadur Bay (about 61° 36' E. long.) northwards, to lat. 26° 15' N., when it turns eastward to the Nihing River, following which N. and E. to its sources, it passes on to about 63° 12' E. long., when it resumes a northerly direction to Jalk. As thus determined, Baluchistan has an area of about 106,500 sq. miles. It extends from lat. 24° 50' to 30° 20', and from long. 61° 10' to 68° 38'; its extreme length from E. to W. being 500 miles, and its breadth 370.

The outline of the sea-coast is in general remarkably regular, running nearly due E. and W., a little N. of lat. 24° 46' from Cape Monze, on the border of Sindh, to Cape Jewnee, near the River Dustee. It is for the most part craggy, but not remarkably elevated, and has in some places, for considerable distance, a low sandy shore, though almost everywhere the surface becomes much higher inland. The principal headlands, proceeding from E. to W., are Cape Monze or Ras Moarree, which is the eastern headland of Sonmeanee Bay; Goorab Sing; Ras Arubah; Ras Noo, forming the western headland of Gwadel Bay; Ras Jewnee, forming the eastern point of Gwadur Bay, and Cape Zegin

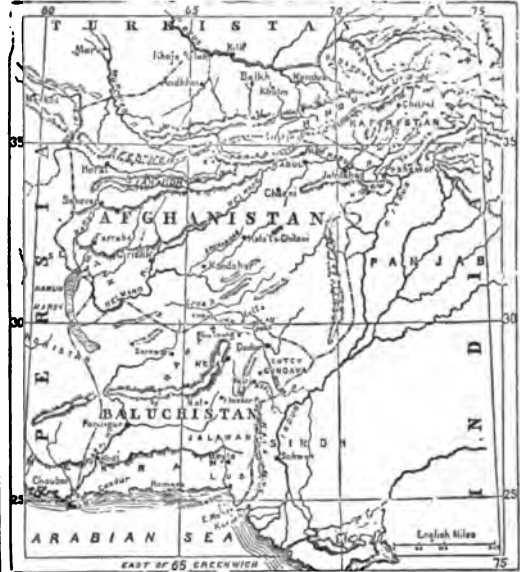

Sketch Map of Baluchistan.

at its western extremity. There is no good harbour along the coast, though it extends about 600 miles; but there are several roadsteads with good holding-ground, and sheltered on several points. Of these the best are Sonmeanee Bay, Hoinara, and Gwadur. On the latter are situated a small town and a fort of the same name, and also a telegraph station of the Indo-European line.

Of the early history of this portion of the Asiatic continent little or nothing is known. The poverty and natural strength of the country, combined with the ferocious habits of the natives, seem to have equally repelled the friendly visits of

inquisitive strangers and the hostile incursions of invading armies. The first distinct account which we have is from Arrian, who, with his usual brevity and severe veracity, narrates the march of Alexander through this region, which he calls the country of the Oritæ and Gadrosii. He gives a very accurate account of this forlorn tract, its general aridity, and the necessity of obtaining water by digging in the beds of torrents; describes the food of the inhabitants as dates and fish; and adverts to the occasional occurrence of fertile spots, the abundance of aromatic and thorny shrubs and fragrant plants, and the violence of the monsoon in the western part of Mekran. He notices also the impossibility of subsisting a large army, and the consequent destruction of the greater part of the men and beasts which accompanied the expedition of Alexander. At the commencement of the 8th century this country was traversed by an army of the caliphate.

The country derives its name from the Baluches, but the Brahoes are considered the dominant race, from which the ruler of the country is always selected. From whatever quarter these may have arrived, they eventually expelled, under their leader Kumbur, the Hindu dynasty, which at that time governed the country, and conquered Baluchistan for themselves. The Baluches are a quite distinct race, and must have arrived in the country at a subsequent period, probably in small bodies, some of which may have come from Syria or from Arabia; in proof of this the Kyheres, for instance, possess a remarkably handsome breed of horses showing unmistakable Arab blood. Anyhow, so marked is the social distinction between Baluch and Brahoes, that when the khan assembles his forces for war the latter tribes demand, as their right, wheaten flour as a portion of their daily rations, while the Baluch tribes are only entitled to receive that made from a coarse grain called jowar. There is also a Persian colony known as the Dehwars; and a considerable number of Hindus, who appear to have been the first settlers in the Brahoes mountains on their expulsion from Sindh, Lus, and Mekran by the caliphs of Baghdad.

Taking a general view on the subject of the original inhabitants of Baluchistan, we may conclude that they have, from a very early date, been reinforced by emigration from other countries, and from stragglers dropped from the hosts of the numerous conquerors, from Alexander to Nadir Shah, who have passed and repassed through Baluchistan or its neighbourhood on their way to and from India. Thus we find the Saka tribe located on the plains of Gressia, on the borders of Mekran, the ancient Gedrosia, and still further to the west, the Dahoe. These tribes are on the direct line of Alexander's march; and we know that tribes of this name from the shores of the Caspian accompanied his army. In Sarawan we find the Sirperra, and Pliny tells us that a tribe called Sarapara resided near the Oxus. Further, on the Dushti-be-doulets, a plain at the northern entrance of the Bolan Pass, we find the Kurds, a name, again, familiar as that of a celebrated and ancient nation. The names of numerous other tribes might be cited to support this view, but it would require too much space to follow up the subject. Both Brahoes and Baluches are Mahometans of the Suni persuasion.

The precise period at which the Brahoes gained the mastery cannot be accurately ascertained; but it was probably about two centuries ago. The last rajah of the Hindu dynasty found himself compelled to call for the assistance of the mountain shepherds, with their leader, Kumbur, in order to check the encroachments of a horde of depredators, headed by an Afghan chief, who infested the country, and even threatened to attack the seat of government. Kumbur successfully performed the service for which he had been engaged; but having in a few years

quelled the robbers, against whom he had been called in, and finding himself at the head of the only military tribe in the country, he formally deposed the rajah and assumed the government.

The history of the country after the accession of Kumbur is as obscure as during the Hindu dynasty. It would appear, however, that the sceptre was quietly transmitted to Abdulla Khan, the fourth in descent from Kumbur, who, being an intrepid and ambitious soldier, turned his thoughts towards the conquest of Cutch-Gundava, then held by different petty chiefs, under the authority of the Nawabs of Sindh.

After various success, the Kumburanes at length possessed themselves of the sovereignty of a considerable portion of that fruitful plain, including the chief town, Gundava. It was during this contest that the famous Nadir Shah advanced from Persia to the invasion of Hindustan; and while at Kandahar, he despatched several detachments into Baluchistan, and established his authority in that province. Abdulla Khan, however, was continued in the government of the country by Nadir's orders; but he was soon after killed in a battle with the forces of the Nawabs of Sindh. He was succeeded by his eldest son, Hajee Mohummud Khan, who abandoned himself to the most tyrannical and licentious way of life, and alienated his subjects by oppressive taxation. In these circumstances Nusseer Khan, the second son of Abdulla Khan, who had accompanied the victorious Nadir to Delhi, and acquired the favour and confidence of that monarch, returned to Khelat, and was hailed by the whole population as their deliverer. Finding that expostulation had no effect upon his brother, he one day entered his apartment and stabbed him to the heart. As soon as the tyrant was dead, Nusseer Khan mounted the *musnud*, amidst the universal joy of his subjects; and immediately transmitted a report of the events which had taken place to Nadir Shah, who was then encamped near Kandahar. The shah received the intelligence with satisfaction, and despatched a firman, by return of the messenger, appointing Nusseer Khan beglerbey of all Baluchistan. This event took place in the year 1739.

Nusseer Khan proved an active, politic, and warlike prince. He took great pains to re-establish the internal government of all the provinces in his dominions, and improved and fortified the city of Khelat. On the death of Nadir Shah in 1747, he acknowledged the title of the king of Cabul, Ahmed Shah Abdulla. In 1768 he declared himself entirely independent; upon which Ahmed Shah despatched a force against him, under one of his ministers. The khan, however, raised an army and totally routed the Afghan army. On receiving intelligence of this discomfiture, the king himself marched with strong reinforcements, and a pitched battle was fought, in which Nusseer Khan was worsted. He retired in good order to Khelat, whither he was followed by the victor, who invested the place with his whole army. The khan made a vigorous defence; and, after the royal troops had been foiled in their attempts to take the city by storm or surprise, a negotiation was proposed by the king, which terminated in a treaty of peace. By this treaty it was stipulated that the king was to receive the cousin of Nusseer Khan in marriage; and that the khan was to pay no tribute, but only, when called upon, to furnish troops to assist the armies, for which he was to receive an allowance in cash equal to half their pay. The khan frequently distinguished himself in the subsequent wars of Cabul; and, as a reward for his services, the king bestowed upon him several districts in perpetual and entire sovereignty. Having succeeded in quelling a dangerous rebellion, headed by his cousin Beheram Khan, this able prince at length died in extreme old age, in the month of June 1795, leaving three sons and five daughters. He



was succeeded by his eldest son Muhmood Khan, then a boy of about fourteen years. During the reign of this prince, who has been described as a very humane and indolent man, the country was distracted by sanguinary broils; the governors of several provinces and districts withdrew their allegiance; and the dominions of the khans of Khelat gradually so diminished, that they now comprehend only a small portion of the provinces formerly subject to Nusseer Khan.

In 1839, when the British army advanced through the Bolan Pass towards Afghanistan, the conduct of Mehrab Khan, the ruler of Baluchistan, was considered so treacherous and dangerous, as to require "the exaction of retribution from that chieftain," and "the execution of such arrangements as would establish future security in that quarter." General Willshire was accordingly detached from the army of the Indus with 1050 men to assault Khelat. A gate was knocked in by the field-pieces, and the town and citadel were stormed in a few minutes. Above 400 Baluches were slain, among them Mehrab Khan himself; and 2000 prisoners were taken. Subsequent inquiries have, however, proved that the treachery towards the British was not on the part of Mehrab Khan, but on that of his vizier, Mahomed Haseein, and certain chiefs with whom he was in league, and at whose instigation the British convoys were plundered in their passage through Cutch-Gundava and in the Bolan Pass. The treacherous vizier, however, made our too credulous political officers believe that Mehrab Khan was to blame,—his object being to bring his master to ruin and to obtain for himself all power in the state, knowing that Mehrab's successor was only a child. How far he succeeded in his object history has shown. In the following year Khelat changed hands, the governor established by the British, together with a feeble garrison, being overpowered. At the close of the same year it was reoccupied by the British under General Nott. In 1841, Nusseer Khan, the youthful son of the slain Mehrab Khan, was recognized by the British, who soon after evacuated the country.

From the conquest of Sindh by the British troops under the command of the late General Sir Charles Napier in 1843 up to 1854, no diplomatic intercourse occurred worthy of note between the British and Baluch states. In the latter year, however, under the governor-generalship of the late marquis of Dalhousie, the late General John Jacob, C.B., at the time political superintendent and commandant on the Sindh frontier, was deputed to arrange and conclude a treaty between the Khelat state, then under the chieftainship of Meer Nusseer Khan, and the British Government. This treaty was executed on the 14th of May 1854, and was to the following effect:—

"That the former offensive and defensive treaty, concluded in 1841 by Major Outram between the British Government and Meer Nusseer Khan, chief of Khelat, was to be annulled.

"That Meer Nusseer Khan, his heirs and successors, bound themselves to oppose to the utmost all the enemies of the British Government, and in all cases to act in subordinate co-operation with that Government, and to enter into no negotiations with other states without its consent.

"That should it be deemed necessary to station British troops in any part of the territory of Khelat, they shall occupy such positions as may be thought advisable by the British authorities.

"That the Baluch chief was to prevent all plundering on the part of his subjects within, or in the neighbourhood of, British territory.

"That he was further to protect all merchants passing through his territory, and only to exact from them a transit duty, fixed by schedule attached to the treaty; and

that, on condition of a faithful performance of these duties, he was to receive from the British Government an annual subsidy of 50,000 rupees (£5000)."

The provisions of the above treaty were most loyally performed by Meer Nusseer Khan up to the time of his death in 1856. He was succeeded by his brother, Meer Khodadad Khan, the present ruler, a youth of twelve years of age, who, however, did not obtain his position before he had put down by force a rebellion on the part of his turbulent chiefs, who had first elected him, but, not receiving what they considered an adequate reward from his treasury, sought to depose him in favour of his cousin Shere dil Khan. In the latter part of 1857, the Indian rebellion being at its height, and the city of Delhi still in the hands of the rebels, a British officer (Major Henry Green) was deputed, on the part of the British Government, to reside, as political agent, with the khan at Khelat, and to assist him by his advice in maintaining control over his turbulent tribes. This duty was successfully performed until 1863, when, during the temporary absence of Major Malcolm Green, the then political agent, Khodadad Khan was, at the instigation of some of his principal chiefs, attacked, while out riding, by his cousin, Shere dil Khan, and severely wounded. Khodadad fled in safety to a residence close to the British border, and Shere dil Khan was elected and proclaimed khan. His rule was, however, a short one, for, early in 1864, when proceeding to Khelat, he was murdered in the Gundava Pass; and Khodadad was again elected chief by the very men who had only the previous year caused his overthrow, and who had lately been accomplices to the murder of his cousin. Since the above events Khodadad has maintained his precarious position with great difficulty; but owing to his inability to govern his unruly subjects without material assistance from the British Government, which they are not disposed to give, his country has gradually fallen into the greatest anarchy; and, consequently, some of the provisions of the treaty of 1854 having been broken, diplomatic relations have been discontinued with the Khelat state since the end of 1874.

The territories of Baluchistan are now comprised under the following divisions—Jalawan, Samwan, Khelat, Mekran, Lus, Cutch-Gundava, and Kohistan.

The most remarkable features of this extensive country are its rugged and elevated surface, its barrenness, and its deficiency of water. The mass of mountains which forms the eastern boundary of that division of Baluchistan called the Kohistan, or mountain territory, lying between the capital, Khelat (lat. 29° 1' 38" N., long. about 66° 39' E.), and the plain country, to the east of it, designated Cutchee, or Cutch-Gundava, is composed of several parallel ranges of limestone rock, in close proximity to each other, having a general strike of N.N.E. to S.S.W. and a breadth of about 55 miles. This range originates in Afghanistan, and enters Baluchistan north of the Bolan Pass in about 30° N. lat. and about 60° 30' E. long. under the name Herbooe; and, after throwing out a branch to the eastward, which touches the River Indus at Schwam, terminates under the designation of the Hala Mountains, at Cape Monze on the coast of the Arabian Sea, W. of Kurrachee, in about 25° N. lat. and 66° 68' E. long., thus having a total length of upwards of 300 miles. The highest mountain of this range is the Chehil Tan, bearing about N. by E., 85 miles from Khelat, and attaining an altitude of 12,000 feet above the sea. The western range of the Herbooe Mountains in this portion of Baluchistan are barren and without timber, and scantily peopled with pastoral tribes of Brahoes, who emigrate to the plains of Cutchee on the approach of the winter months.

North of the Bolan River and Pass the Herbooe Mountains are met, in about lat. N. 30°, by confused ranges

of rough precipitous mountains, which extend to the eastward with a strike nearly E. and W. to the Sooliman range, in about 29° 5' N. lat. and about 69° 30' E. long. This tract is almost entirely inhabited by Murrees, Boogtees, and other tribes of Baluch plunderers, and is bounded on the N. by the province of Sewestan. South of these ranges lies the desert country, which touches the Sindh frontier in 28° 27' N. lat.

The two principal water-courses which drain the Kohistan portion of Baluchistan E. of Khelat are the rivers Bolan and Moola, the former rising about 60 miles N.E. of Khelat, the latter at Anjeers, lat. 28° 19' N., long. about 66° 29' E., about 45 miles south of that city. They both discharge themselves into the plains of Cutchee, the former at Dadur, lat. about 29° 28' 51" N., long. about 67° 26' E., and the latter at Kotra near Gundava, lat. 28° 33' 47" N., long. about 67° 26' E. There is at all seasons a plentiful supply of clear running water in these streams, which is entirely used up for irrigational purposes on issuing into the plains. They are subject to dangerous floods from sudden storms in the neighbouring mountains during the rainy season. The two easiest and safest passes from Central Asia into India take their names from these streams. South of the Moola the Gaj River issues into the plains, and its waters are also absorbed in cultivation. The Nara issues into the plains near Kujjuk, N.W. corner of Cutch-Gundava, in lat. about 29° 36' N., and long. about 68° 2' E.; ordinarily its water is utilized entirely for cultivation in its course through the Afghan province of Seebee; but at periods of heavy rains in the mountains it is liable to burst its banks, and then inundates immense tracts in the Cutchee desert to the south.

West of Khelat, as far as about 65° 30' E. long., the mountain ranges have much the same strike, and are of the same nature as those to the eastward, but the ranges are much narrower, more defined, and of a lower altitude. The valleys between them vary from 5 to 15 miles in breadth; they are quite devoid of trees. The water-courses generally follow the direction of the hills from N. to S. and in some instances during heavy rains their waters reach the Arabian Sea; but as a general rule they are absorbed long before they reach the coast, partly in cultivation, but principally by the sandy arid nature of the soil and excessive dryness of the atmosphere,—due, probably, to the proximity of the great desert west of Kharan, which extends to the confines of Persia. The most important of these water-courses is the Dustee or Moolaeue.

The climate of Baluchistan is extremely various in the different provinces. The soil in general is exceedingly stony. In the province of Cutch-Gundava, however, it is rich and loamy, and so very productive, that, it is said, were it all properly cultivated, the crops would be more than sufficient for the supply of the whole of Baluchistan. Gold, silver, lead, iron, tin, antimony, brimstone, alum, sal-ammoniac, and many kinds of mineral salts, and saltpetre, are found in various parts of the country. The precious metals have only been discovered in working for iron and lead, in mines near the town of Nal, about 150 miles S.S.W. of Khelat. The different other minerals above enumerated are very plentiful. The gardens of Khelat produce many sorts of fruit, which are sold at a very moderate rate, such as apricots, peaches, grapes, almonds, pistachio-nuts, apples, pears, plums, currants, cherries, quinces, figs, pomegranates, mulberries, plantains, melons, guavas, &c. All kinds of grain known in India are cultivated in the different provinces of Baluchistan, and there is abundance of vegetables. Madder, cotton, and indigo are also produced; and the latter is considered superior to that of Bengal. Great attention is given to the culture of the date fruit in the province of Mekran.

The domestic animals of Baluchistan are horses, mules, asses, camels, buffaloes, black-cattle, sheep, goats, dogs, and cats, besides fowls and pigeons; but there are neither geese, turkeys, nor ducks. The wild animals are tigers, leopards, hyenas, wolves, jackals, tiger-cats, wild dogs, foxes, hares, mangooses, mountain goats, antelopes, elks, red and moose deer, wild asses, &c. Of birds they have almost every species to be met with either in Europe or India.

The principal towns in Baluchistan are as follows:—**KHELAT** is the capital of the whole country; *Mustoong*, of the province of Sarawan; *Koodar*, of Jalawan; *Beylea*, of Beylea; *Koj*, of Mekran; *Bagh*, of Cutch-Gundava; and Dadur and Gundava are towns in the last-mentioned province.

The capital stands on an elevated site 7000 feet above the sea, on the western side of a well-cultivated plain or valley, about eight miles long and two or three broad, a great part of which is laid out in gardens and other enclosures. The town is built in an oblong form, and on three sides is defended by a mud wall, 18 or 20 feet high, flanked, at intervals of 250 yards, by bastions, which, as well as the wall itself, are pierced with numerous loopholes for matchlock-men. The defence of the fourth side of the city has been formed by cutting away perpendicularly the western face of the hill on which it is partly built. On the summit of this eminence stands the palace, commanding a distinct view of the town and adjacent country. That quarter of the hill on which the khan's residence is erected has been enclosed by a mud wall, with bastions; the entrance to it is on the south-western side; and here, as well as at the city gates, which are three in number, there is constantly a guard of matchlock-men. Both town and citadel are, however, completely commanded by the surrounding hills, and are incapable of offering any resistance against artillery. Within the walls there are upwards of 2500 houses, and the number of these in the suburbs probably exceeds one-half of that amount. The houses are mostly built of half-burnt brick or wooden frames, and plastered over with mud or mortar. In general, the streets are broader than those of native towns, and most of them have a raised pathway on each side for foot-passengers, and have also an uncovered kennel in the centre, which is a nuisance, from the quantity of filth thrown into it, and the stagnant rain-water that lodges there. The upper stories of the houses frequently project across the street, and thereby render the part beneath them gloomy and damp. This seems a very rude attempt to imitate the bazars of Persia and Cabul. The bazaar of Khelat is extensive, well furnished with every kind of goods; all the necessaries of life may be purchased there at a moderate price. The town is supplied with delicious water from a spring in the face of a hill on the opposite side of a plain, whence it meanders nearly through its centre, having the town and suburbs on one side, and on the other the gardens. It may be remarked of this spring, that the waters, at their immediate issue from the smaller channels, possess a considerable degree of tepidity until after sunrise, when they suddenly become exceedingly cold, and remain so during the day.

We have no data from which we can form an accurate computation of the population of Baluchistan, but it may be estimated at about 400,000. The two great races of Baluch and Brahoes, each subdivided into an infinite number of tribes, are clearly distinguished from each other by their language and appearance. The Baluch, or Baluchekee, language partakes considerably of the idiom of the modern Persian, although greatly disguised under a singularly corrupt pronunciation. The Brahoes, on the other hand, has nothing analogous to Persian, but appears to contain a

great number of ancient Hinduee words; and, as it strikes the ear, bears a strong resemblance to the dialect spoken in the Panjaub. The Baluches in general have tall figures, long visages, and raised features: the Brahoes, on the contrary, have short, thick bones, with round faces and flat lineaments.

The Baluches are a handsome, active race of men, not possessing great physical strength, but inured to changes of climate and season, and capable of enduring every species of fatigue. In their habits they are pastoral and much addicted to predatory warfare, in the course of which they do not hesitate to commit every kind of outrage and cruelty. Notwithstanding their predatory habits, however, they are considered to be a hospitable people. After the fashion of other barbarous tribes in that part of the world, they will protect and kindly entertain a stranger while their guest, but feel no scruple in robbing and murdering him as soon as he has left their precincts. They are indolent, and unless excited by amusement or war, or compelled to action by some urgent motive, spend their time in idleness, rude dissipation, and the enjoyment of such coarse luxuries as they can procure—in lounging, gambling, smoking tobacco or hemp, and chewing opium. The tenets of their religion,—and still more, perhaps, their poverty,—preserve them from the abuse of fermented liquors. Their principal articles of food are milk in all its forms, the flesh of domestic animals, not excepting that of the camel, and game, including wild asses, the flesh of which is considered a delicacy. Their appetites are voracious; they consume incredible quantities of flesh when it can be obtained, and prefer it in a half-cooked state. They also use grain in the form of bread, and prepared variously otherwise; but they enjoy most such articles of food or condiment as possess a strong and stimulating flavour, as capsicum, onions, and garlic. Their indolence prompts them to keep as many slaves as they can obtain and support. Polygamy is universal. Some of the lower orders have as many as eight women, either as wives or mistresses, and the number is increased in proportion to the rank and means of the man. Wives are obtained by purchase, payment being made in cattle or other articles of pastoral wealth. The ceremony of marriage is performed by the moollah or priest; and on this occasion, as well as on some others affecting females, practices similar to those of the Levitical law are observed. For instance, in this country, as also among the Afghans, a man is expected to marry the widow of a deceased brother. When a death takes place, the body is watched for three successive nights by assembled friends and neighbours, who spend their time in feasting, so that the ceremony seems intended rather to furnish enjoyment to the living than to render honour to the dead.

The common dress of the Brahoes is a coarse white or blue calico shirt, buttoned round the neck, and reaching below the knee; their trousers are made of the same cloth, or of a kind of striped stuff called soosee, and puckered round the ankles. On their heads they wear a small silk or cotton quilted cap, fitted to the shape of the skull, and a *kumwurband* or sash, of the same colour, round their waists. The Baluches wear a similar dress, but a turban on the head and wide trousers unconfined at the ankle. In winter the chiefs and their relatives appear in a tunic of chintz, lined and stuffed with cotton; and the poorer classes, when out of doors, wrap themselves up in a surlout made of cloth, manufactured from a mixture of goats' hair and sheep's wool. The women's dress is very similar to that of the men; their trousers are preposterously wide, and made of silk, or a mixture of silk and cotton.

The fluctuation of power renders it difficult to define precisely the nature of the government of Khelat. During

the reign of Nusseer Khan the whole kingdom might be said to have been governed by a complete despotism; yet that ruler so tempered the supreme authority by the privileges granted to the feudal chiefs within their own tribes, that, to a casual observer, it bore the appearance of a military confederation. The tribes all exercise the right of selecting their own *sirdar*, or head; and the khan has the power of confirming or disapproving of their nomination; but this power is never exercised, and appears to be merely nominal. The khan of Khelat declares war and makes treaties connected with the whole of Baluchistan, and can order the *sirdar* of each tribe to attend in person with his quota of troops. Agreeably to a code of regulations framed by one of the earliest princes of the Kumburane dynasty, the entire administration of justice was vested in the person at the head of the government. The *sirdar*, however, has the power of adjusting petty quarrels, thefts, and disputed points of every description, among the inhabitants of a *kheil* or society; but, in all cases of importance, an appeal lies in the last instance to the khan at Khelat.

The amount of revenue enjoyed by the khan of Khelat is inconsiderable, as the ruling races, Baluch and Brahoe, pay no direct taxes, and their poverty and simple habits prevent them from contributing much indirectly. His income is therefore derived from his resources as a proprietor of lands or towns; from a proportion of the produce paid in kind by the Afghan, Dehwar, and Jet cultivators; from dues on direct and transit trade; and from arbitrary exactions, a never-failing mode with Eastern potentates of recruiting an exhausted treasury. Pottinger estimated the amount at 350,000 rupees; Masson, who had ample means of acquiring information through colloquial channels, at 300,000. At the present date (1875) it is 300,000 rupees or £30,000 at the utmost. With such a revenue it is obvious that no standing army can be maintained; and Masson, certainly very competent to the task of acquiring information on this subject, states that Mehrab Khan, "nearly destitute of troops in his own pay, was compelled, on the slightest cause for alarm, to appeal to the tribes, who attended or otherwise as suited their whims or convenience." Pottinger computed the number of available fighting men at 60,000. Mehrab Khan could on no occasion assemble more than 12,000; and in his final struggle for property, power, and life, the number of his troops did not amount to 3000. At the present time (1875) about 40,000 would probably be available if all attended the summons, but the utmost number the khan could collect would be about 10,000. All depends upon the state of the treasury, the cause of the war, and the power the khan may be able to exert over his chiefs. The Baluch soldier is heavily encumbered with arms, carrying a matchlock, a sword, a dagger, and a shield. Pottinger considered them good marksmen, and states that in action they trust principally to their skill in this respect, avoiding close combat; but their readiness in general to close with the British troops shows that he is in this instance mistaken. There were no Brahoes opposed to our forces at the battle of Meanee, nor were there any Baluches from Baluchistan. The levies of the Ameer of Sindh were principally composed of Sindhee and Baluch tribes, who had long been settled in Sindh. The greater part serve on foot; but a number, not inconsiderable, have horses. Camels are only used by tribes on the western borders of Baluchistan in their predatory excursions.

BALUE, JEAN, a French cardinal, who raised himself from a very mean station to dignity and honour. He was born of very humble parentage at Anglé in Poitou, in 1421, and was first patronised by the bishop of Poitiers. He eventually became almoner to Louis XI., and managed to secure a considerable share in the government; but

being detected in treasonable correspondence with the duke of Bourgogne, he was confined by Louis in an iron cage 8 feet square. On his release, however, eleven years afterwards, he was loaded with honours by Sixtus IV., was sent as legate to France, and received the bishopric of Albano. He died at Ancona in 1491.

BALUZE, ETIENNE, a celebrated French scholar, was born at Tulle on the 24th of December 1630, and died in July 1718. After completing his education at the university of Toulouse, he was invited by M. de Marca, afterwards archbishop of Paris, to undertake the superintendence of his library. De Marca died in 1662, and Baluze, after acting as librarian to Le Tellier and the archbishop of Auch, obtained in 1667 a similar situation with the famous Colbert, which he retained till 1700, some years after the death of that minister. His reputation and his mastery of French law and antiquities obtained for him in 1670 the professorship of canon law in the royal college, a chair founded expressly for him. On the fall of the Cardinal de Bouillon in 1710, Baluze, who had attached himself to his party, was removed by a *lettre de cachet* from Paris, and transferred from Rouen to Blois, Tours, and Orleans in succession. He obtained his recall in 1713, though he never recovered his professorship. Of Baluze's numerous works the best known is the *Capitularia Regum Francorum*, which is of considerable historical value. The *Miscellanea*, in 7 vols., contain several curious extracts from manuscripts found by him in the libraries at Paris.

BALZAC, HONORÉ DE, perhaps the greatest name in the post-Revolutionary literature of France, was born at Tours in 1799, and died in 1858. His date thus corresponds with the whole period of the rise, the acme, and the decline of the Romantic school, to which he can scarcely, however, be said to have belonged. It is true that he was inspired by many of the influences that animated Victor Hugo and his followers. Like them he was much occupied by the study of the fantastic element in mediæval art, so strongly opposed to the calm and limit of classical literature, like them he reproduced the remoter phases of life and passion, and thought that few subjects were so base or obscure as to be unworthy of artistic treatment. But there is something in the powerful personality of Balzac indicated by the colossal body, by the strong and sensual face, somewhat resembling the profile of the Emperor Nero, which preserved him from the mannerism of any school. He was never successful in reproducing the existence of the past, he was essentially the man of his own day, and *La Comédie Humaine* is as much the picture of the 19th, as the *Divina Commedia* is of the 13th century. The passions that move his characters are the intense desire of boundless wealth, of luxury, of social distinction; and though here and there his financiers, his journalists, his political intriguers, his sordid peasantry, are relieved by the introduction of some pure figure, like that of Eugénie Grandet, of David, or of Eve, there are only too many elaborate studies of creatures sunk below the surface of humanity, the embodiments of infinite meanness and nameless sin. He was merely "the secretary of society," he said, and "drew up the inventory of vices and virtues." His ambition was, "by infinite patience and courage, to compose for the France of the 19th century that history of morals which the old civilizations of Rome, Athens, Memphis, and India, have left untold." The consequence of this ambition is, that Balzac's voluminous romances have too often the air of a minute and tedious chronicle, and that the contemporary reader is wearied with a mass of details about domestic architecture, about the stock exchange, and about law, which will prove invaluable to posterity.

Balzac's private history, which may be traced through

many passages of his novels, was a strange and not a happy one. He was early sent from his home in Tours to the college of Vendôme, where he neglected the studies and sports of childhood to bury himself in mystic books and mystic reveries. He has told the story of his school life in *Louis Lambert*, how he composed a *théorie de la volonté*, a theory which was to complete the works of Meamer, Lavater, Gall, and Bichat. This promising treatise was burned by one of the masters of the school; and Balzac, falling into bad health, returned home. The next stage in his education was a course of study at the Sorbonne, and of lectures on law. In the offices of *avoués* and notaries he picked up his knowledge of the by-ways of chicanery,—knowledge which he uses only too freely in his romances. Nature did not mean Balzac for an advocate; he was constant in the belief in his own genius, a belief which for many years he had all to himself, and his family left him to work and starve, on the scantiest pittance, in a garret of the Rue Lesdiguières. There followed ten years of hard toil, poverty, experiments in this and that way of getting a living. These struggles are described in *Facino Cane*, in the *Peau de Chagrin*, and in a series of letters to the author's sister, Madame de Surville. Balzac found "three sous for bread, two for milk, and three for firing" suffice to keep him alive, while he devoured books in the library of the Arsenal, copied out his notes at night, and then wandered for hours among the scenes of nocturnal Paris. "Your brother," he writes to Madame de Surville, "is already nourished like a great man,—he is dying of hunger." He tried to make money by scribbling many volumes of novels without promise, and borrowed funds to speculate in the business of printing. Ideas which have since made other men's fortunes failed in Balzac's hands, and he laid the foundations of those famous debts which in later life were his torment and his occupation. At length appreciation came, and with appreciation what ought to have been wealth. Balzac was unfortunately as prodigal of money as of labour; he would shut himself up for months, and see no one but his printer; and then for months he would disappear and dissipate his gains in some mysterious hiding-place of his own, or in hurried travelling to Venice, Vienna, or St Petersburg. As a child he had been a man in thought and learning; as a man he was a child in caprice and extravagance. His imagination, the intense power with which he constructed new combinations of the literal facts which he observed, was like the demon which tormented the magician with incessant demands for more tasks to do. When he was not working at *La Comédie Humaine*, his fancy was still busy with its characters; he existed in an ideal world, where some accident was always to put him in possession of riches beyond the dreams of avarice. Meantime he squandered all the money that could be rescued from his creditors on sumptuous apparel, jewels, porcelain, pictures. His excesses of labour, his sleepless nights, his abuse of coffee undermined his seemingly indestructible health. At length a mysterious passion for a Russian lady was crowned by marriage; the famous debts were paid, the visionary house was built and furnished, and then, "when the house was ready, death entered." Balzac died at the culmination of his fame, and at the beginning, as it seemed, of the period of rest to which he had always looked forward.

It is impossible to enter on a detailed criticism of Balzac's novels. In them he scales every height and sounds every depth of human character,—from the purity of the mysterious Seraphitus Seraphita, cold and strange, like the peaks of her northern Alps, to the loathsome sins of the Marnefs, whose deeds should find no calendar but that of Hell. In the great divisions of his *Comédie*, the scenes of private and of public life of the provinces and of the city,

in the philosophic studies, and in the *Contes Drolatiques*, Balzac has built up a work of art which answers to a mediæval cathedral. There are subterranean places, haunted by the Vautrins and "Filles aux yeux d'or;" there are the seats of the money-changers, where the Nucingens sit at the receipt of custom; there is the broad platform of everyday life, where the journalists intrigue, where love is sold for hire, where splendours and miseries abound, where the peasants cheat their lords, where women betray their husbands; there are the shrines where pious ladies pass saintly days; there are the dizzy heights of thought and rapture, whence falls a ray from the supernatural light of Swedenborg; there are the lustful and hideous grotesques of the *Contes Drolatiques*. Through all swells, like the organ-tone, the ground-note and mingled murmur of Parisian life. The qualities of Balzac are his extraordinary range of knowledge, observation, sympathy, his steadfast determination to draw every line and shadow of his subject, his keen analysis of character and conduct. His defects are an over-insistence on detail, which hampers and bewilders rather than aids the imagination of his readers; his tortured style, "a special language forged out of all the slangs, all the terminologies of science, of the studio, the laboratory, the *cosmétiques*;" his fondness for dwelling on the morbid pathology of human nature. With all these defects, and with the difficulty of judging any one of his tales separately, because each is only a fragment in the development of the immense *Comédie Humaine*, Balzac holds a more distinct and supreme place in French fiction than perhaps any English author does in the same field of art.

(A. L.)

BALZAC, JEAN LOUIS GUERIN DE, a celebrated French writer, was born at Angoulême in 1594. His father was possessed of considerable property, and he himself was early befriended by the Cardinal de la Valette, who took him in his train to Rome. His letters written from that place to his acquaintances and to many who held a high position at the French court, were expressed so admirably, and showed such powers of eloquence, as to gain for him the highest renown. On his return from Italy he was at once and everywhere received as a master in the art of composition. The most extravagant compliments were showered upon him, and his head appears to have been turned a little by his success. In 1624 a collection of his *Letters* was published, and was received with great favour by the public. Soon afterwards a direct charge of plagiarism was made against Balzac in a pseudonymous tract, *On the conformity of M. de Balzac's Eloquence with that of the Greatest Personages of Past and Present Time*. A terribly fierce paper war was excited by this pamphlet; and Balzac, in disgust, retired to his own estate, where he continued his labour of composition. In 1634 he expressed a desire to enter the Academy, and was at once elected with universal acclamation. He died at Paris in 1654. His fame rests entirely upon the *Letters*, which, though empty, bombastic, and affected in matter, are written with great skill, and show a real mastery over the language. They introduced a new style; and Balzac has thus the credit of being the first reformer of French prose, as his contemporary Malherbe was the first reformer of French poetry.

BAMBABA, a province of Congo, on the western coast of Africa, lying to the S. of the River Ambriz. This district is fertile, abounds in gold, silver, copper, salt, &c., and is said to be thickly populated. Its chief town, which bears the same name, was formerly of considerable importance, the climate being remarkably healthy for that region of Africa.

BAMBARRA, a country of inner Africa, on the Joliba or Upper Niger. The principal towns are Segu, Sansading, Jamina, Muraha, Jabbi, Sai, Kullikoro, Maraca-Duba, and

Damba, in many of which the Mahometans have mosques. For further particulars see AFRICA, vol. i. p. 271.

BAMBARRA, a town of western Africa on a backwater of the Niger, of considerable commercial importance, and situated in a fertile plain, 115 miles S.S.W. of Timbuctoo. (See Barth's *Travels in Central Africa*, vol. iv. p. 354.)

BAMBERG, a town of Bavaria, in the circle of Upper Franconia, on the River Regnitz, 3 miles above its junction with the Maina, and 33 miles N. of Nuremberg, with which it is connected by railway. It is partially surrounded by walls and ditches, and is divided by the river and Ludwig's canal into three districts, which are connected by handsome bridges. The town is well built, and the streets are well paved and lighted. The cathedral, a noble structure in the Byzantine style of architecture, is surpassed by few of the kind in Germany. It was founded in 1004 by the Emperor Henry II., and finished in 1012, but was afterwards partially burnt, and rebuilt in 1110. It contains the tombs of the founder and his empress Cunigunde, Conrad III., Pope Clement II., &c., and numerous monuments and paintings by eminent masters. Among the other public buildings are St Martin's church, the palace (formerly the residence of the prince-bishops), town-house, and theatre. The Benedictine convent of St Michael was turned, in 1803, into a charitable institution for poor citizens known as Ludwig's hospital. Bamberg has numerous literary and charitable institutions, as the lyceum, gymnasium, polytechnic, normal, and medical schools, a library, museum, picture-gallery, hospital, and workhouse. The trade is considerable; cloths, sealing-wax, leather, tobacco, musical instruments, carriages, &c., are manufactured, and there are numerous breweries. The whole of the neighbouring district is like a vast garden, and furnishes large supplies of liquorice, carrots, aniseed, coriander, and other seeds. Bamberg was formerly the capital of an independent bishopric, which was secularized in 1801, and assigned to Bavaria in 1803. Population, 25,738.

BAMBOCCIO. See LAER, PETER VAN.

BAMBOO, a genus (*Bambusa*) of arboreous grasses very generally distributed throughout the tropical lands of the globe, but found and cultivated especially in India, China, and the East Indian Archipelago. There is a large number of species enumerated; but, as is the case with most plants under cultivation, much difficulty is found in distinguishing species from varieties produced by artificial selection. *Bambusa arundinacea* is the species most commonly referred to. It is a tree-like plant, rising to a height of 40, 60, or even 80 feet, with a hollow stem, shining as if varnished. The stem is extremely slender, not exceeding the thickness of 5 inches in some which are 50 feet high, and in others reaching 15 or 18 inches in diameter. The whole is divided into joints or septa called knots or internodes, the intervals between which in the case of some of the larger stems is several feet. These joints or divisions are formed by the crossing of the vascular bundles of fibres. They produce alternate lateral buds, which form small alternate branchlets springing from the base to the top, and, together with the narrow-pointed leaves issuing from them, give the plant an elegant feathered appearance as it waves in the wind. The rapidity of its growth is surprising. It attains its full height in a few months, and Mr Fortune records the observation of a growth of from 2 to 2½ feet in a single day. In Malabar it is said to bear fruit when fifteen years old, and then to die.

The bamboo is cultivated with great care in regular plantations by the Chinese. The plant is propagated by shoots or suckers deposited in pits 18 inches or 2 feet deep at the close of autumn or the beginning of winter. Various expedients are followed to obtain good bamboos; one of the most usual being to take a vigorous root and transplant

it, leaving only four or five inches above the joint next the ground. The cavity is then filled with a mixture of horse-litter and sulphur. According to the vigour of the root, the shoots will be more or less numerous; they are destroyed at an early stage during three successive years; and those springing in the fourth resemble the parent tree. The uses to which all the parts and products of the bamboo are applied in Oriental countries are almost endless. The soft and succulent shoots, when just beginning to spring, are cut over and served up at table like asparagus. Like that vegetable, also, they are earthed over to keep them longer fit for consumption; and they afford a continuous supply during the whole year, though it is more abundant in autumn. They are also salted and eaten with rice, prepared in the form of pickles, or candied and preserved in sugar. As the plant grows older, a species of fluid is secreted in the hollow joints, in which a concrete substance, highly valued in the East for its medicinal qualities, called *tabasir* or *tabascheer*, is gradually developed. This substance, which has been found to be a purely siliceous concretion, is possessed of peculiar optical properties. As a medicinal agent the bamboo is almost or entirely inert, and it has never been received into the European materia medica. A decoction of the leaves of the plant is, however, employed in the East for pectoral affections, and the leaf-buds are said to be diuretic. The grains of the bamboo are available for food, and the Chinese have a proverb that it produces seed more abundantly in years when the rice crop fails, which means, probably, that in times of dearth the natives look more after such a source of food. The Hindus eat it mixed with honey as a delicacy, equal quantities being put into a hollow joint, coated externally with clay, and thus roasted over a fire. It is, however, the stem of the bamboo which is applied to the greatest variety of uses. Joints of sufficient size form water buckets; smaller ones are used as bottles, and among the Dyaks of Borneo they are employed as cooking vessels. Bamboo is extensively used as a timber wood, and houses are frequently made entirely out of the products of the plant; complete sections of the stem form posts or columns; split up, it serves for floors or rafters; and, interwoven in lattice-work, it is employed for the sides of rooms, admitting light and air. The roof is sometimes of bamboo solely, and when split, which is accomplished with the greatest ease, it can be formed into laths or planks. It is employed in shipping of all kinds; some of the strongest plants are selected for masts of boats of moderate size, and the masts of larger vessels are sometimes formed by the union of several bamboos built up and joined together.

The bamboo is employed in the construction of all kinds of agricultural and domestic implements, and in the materials and implements required in fishery. Bows are made of it by the union of two pieces with many bands; and, the septa being bored out and the lengths joined together, it is employed, as we use leaden pipes, in transmitting water to reservoirs or gardens. From the light and slender stalks shafts for arrows are obtained; and in the south-west of Asia there is a certain species of equally slender growth, from which writing-pens or reeds are made. A joint forms a holder for papers or pens, and it was in a joint of bamboo that silk-worm eggs were carried from China to Constantinople during the reign of Justinian. The outer cuticle of Oriental species is so hard that it forms a sharp and durable cutting edge, and it is so siliceous that it can be used as a whetstone. This outer cuticle, cut into thin strips, is one of the most durable and beautiful materials for basket-making, and both in China and Japan it is largely so employed. Strips are also woven into cages, chairs, beds, and other articles of furniture, Oriental wicker-work in bamboo being unequalled for beauty and

neatness of workmanship. In China the interior portions of the stem are beaten into a pulp, and used for the manufacture of the finer varieties of paper. Bamboos are imported to a considerable extent into Europe for the use of basket-makers, and for umbrellas and walking-sticks. In short, the purposes to which the bamboo is applicable are almost endless, and well justify the opinion that "it is one of the most wonderful and most beautiful productions of the tropics, and one of Nature's most valuable gifts to uncivilized man" (A. R. Wallace, *The Malay Archipelago*).

**BAMBOROUGH**, a village in Northumberland, on the sea-coast, 14 miles N. of Alnwick. It was a royal borough previous to the Norman Conquest, and returned two members to parliament in the 28d year of Edward I. Its ancient castle stands close to the sea on an almost perpendicular rock, 160 feet in height, and is accessible only on the south-east side. The first erection is ascribed by the Saxon chronicles to King Ida of Northumberland, who is said to have named it *Bebbanburk* after his queen Bebbe (547 A.D.). The principal events in its early history are the siege by Penda in 642, the ravages of the Danes in 993, the unsuccessful defence by De Mowbray against William Rufus, and numerous sieges during the Wars of the Roses. In the reign of Henry VII. it fell into decay. At length, in the 18th century, it became the property of Lord Crewe, bishop of Durham, who, in 1720, vested the castle and manor in trustees for charitable purposes. In virtue of this bequest a patrol is kept on the coast, apartments are provided for shipwrecked seamen, and a storehouse for salvage-goods, and granaries are maintained in order to supply corn to the poor at a cheap rate in times of scarcity. An infirmary, a dispensary, and a large library bequeathed by Dr Sharp, are also maintained, while poor children receive gratuitous education at two "national" schools. Population in 1871, 320 in the village, and 3751 in the parish.

**BAMBOUK**, a country in the interior of Western Africa, situated between the Senegal and its tributary the Falam, and extending from lat. 12° 30' to 14° N., and from long. 10° to 12° 30' W. It is traversed from N.W. to S.E. by the steep and wall-like range of the Tamba-Ura Mountains. The soil in a large part of the country is of remarkable fertility; rice, maize, millet, melons, manioc, grapes, bananas, and other fruits, grow almost without cultivation; the forests are rich in a variety of valuable trees; and extensive stretches are covered with abundant pasturage of the long guinea-grass. As a natural consequence there is great profusion of animal life. The inhabitants, a branch of the Mandingo race, have made but little progress in civilization. The one product of their country which really excites them to labour is gold; and even it is so common and accessible that the rudest methods of collection are deemed sufficient. The most remarkable deposit is at Natakoo, where a considerable hill seems to be wholly composed of auriferous strata. There is also a good mine at Kenieba. In exchange for the gold, cloth, ornaments, and salt—the last a most valuable article—are imported. The usual beast of burden is the ass, the horse being only possessed by the very wealthiest in the country. Sheep and cattle are both pretty numerous. Unfortunately, the climate is very unhealthy, especially in the rainy season, which lasts for about four months, from July or August. The chief towns are Bambouk, Salaba, and Konkuba. The Portuguese early penetrated into Bambouk, and were even for some time masters of the country; but the inhabitants made a general rising and completely drove them out. Remains of their buildings, however, are still to be seen. The French, soon after they had formed their settlement on the Senegal, turned their attention to this land of gold. It was not till 1716, however, that Compagnon, under the auspices of De la Brue, the governor of Senegal, succeeded, by great

address, and not without risk, in visiting various parts of the aridiferous region; and his explorations were followed up by David, Levens, and others. Raffanell visited the country in 1844, and Pascal, a naval lieutenant, was there in 1859. A few commercial stations or *comptoirs* have recently been established.

See Labet, *Bol. de l'Afr. occid.*; De Golbery, *Voy. en Afr. en 1785*; Amédée Tardieu, "Sélempable" in the *Univers pittoresque*; Raffanell, *Voy. dans l'Afr. occid.*, 1844; *Revue algérienne et coloniale* for March 1850; Faidherbe, *Chapitres de géographie and Annuaire de Sénégal*.

**BÁMIÁN**, a once renowned city in the territory now subject to the Afghans, in 34° 50' N. lat., 67° 44' E. long. It remains lie in a valley of the Hazara country, on the chief road from Kábul towards Turkestan, and immediately at the northern foot of that prolongation of the Indian Caucasus now called Koh-i-Baba (see vol. i. pp. 227, 241). The passes on the Kábul side are not less than 11,000 and 12,000 feet in absolute height, and those immediately to the north but little inferior. The river draining the valley is one of the chief sources of the Surkháb or Akarai, an important tributary of the Upper Oxus (*ibid.* p. 241). The prominences of the cliffs which line the valley are crowned by the remains of numerous massive towers, whilst their precipitous faces are for 6 or 7 miles pierced by an infinity of ancient cave-dwellings, some of which are still occupied. The actual site of the old city is marked by mounds and remains of walls, and on an isolated rock in the middle of the valley are considerable ruins of what appears to have been the acropolis, now known to the people as Ghúldílah. But the most famous remains at Bámián are two colossal standing idola, carved in the cliffs on the north side of the valley. Burnes estimates the height of the greater at 120 feet, the other at half as much. These images, which have been much injured, apparently by cannon-shot, are cut in niches in the rock, and both images and niches have been coated with stucco. There is an inscription, not yet interpreted or copied, over the greater idol, and on each side of its niche are staircases leading to a chamber near the head, which shows traces of elaborate ornamentation in azure and gilding. The surface of the niches also has been painted with figures. In one of the branch valleys is a similar colossus, somewhat inferior in size to the second of those two; and there are indications of other niches and idola. As seen from the rock of Ghúldílah, Bámián, with its ruined towers, its colossi, its innumerable grottoes, and with the singular red colour of its barren soil, presents an impressive aspect of desolation and mystery.

That the idola of Bámián, about which so many conjectures have been uttered, were Buddhist figures, is ascertained from the narrative of the Chinese pilgrim, Hwen Thsang, who saw them in their splendour in 630 A.D. His description of the position of the city and images corresponds accurately with modern reports. He assigns to the greater image, which was gilt (the object, probably, of the plaster coating), a height of 140 or 150 feet, and to the second 100. The latter would seem from his account to have been sheathed with copper. Still vaster than these was a recumbent figure, 2 miles east of Bámián, representing Sakya Buddha entering Nirvána, i.e., in act of death. This was "about 1000 feet in length." No traces of this are alluded to by modern travellers, but in all likelihood it was only formed of rubble plastered (as is the case still with such Nirvána figures in Indo-China), and of no durability. For a city so notable Bámián has a very obscure history. It does not seem possible to identify it with any city in classical geography: *Alexandria ad-Oxum* it certainly was not. The first known mention of it seems to be that by Hwen Thsang, at a time when apparently it had already passed its meridian, and was the head of one of the small states into which the empire of the White Huns had broken up. At a later period Bámián was for half a century, ending 1214 A.D., the seat of a branch of the Ghori dynasty, ruling over Tokháristán, or the basin of the Upper Oxus. The place was long besieged, and finally annihilated (1223) by Chinghis Khan, whose wrath was exacerbated at the death of a favourite grandson: by an arrow from its walls. There appears to be no further record of Bámián as a city; but the character of ruins at Ghúldílah agrees with traditions on

the spot in indicating that the city must have been rebuilt after the time of the Mongols, and again perished. In 1840, during the British occupation of Kábul, Bámián was the scene of an action, in which Colonel Denny with a small force routed Dost Mahommed Khan, accompanied by a number of Usbeg chiefs. (Burnes, *Journey to Bokhara*; Masson's *Journeys*, and his papers in the *J. As. Soc., Bengal*; Julian, *Pilgrims Buddhists*; E. Thomas in *J. R. As. Soc., &c.*) (H. Y.)

**BAMPTON**, Rev. JOHN, founder of the series of divinity lectures at Oxford known as the *Bampton Lectures*, appears to have been born in 1689 and to have died in 1751. He was a member of Trinity College, Oxford, and for some time canon of Salisbury. His will directs that eight lectures shall be delivered annually on as many Sunday mornings in full term, "between the commencement of the last month in Lent term and the end of the third week in Act term, upon either of the following subjects:—to confirm and establish the Christian faith, and to confute all heretics and schismatics—upon the divine authority of the Holy Scriptures—upon the authority of the writings of the primitive fathers, as to the faith and practice of the primitive Church—upon the divinity of our Lord and Saviour Jesus Christ—upon the divinity of the Holy Ghost—upon the articles of the Christian faith as comprehended in the Apostles' and Nicene Creeds." The lecturer, who must be at least a Master of Arts of Oxford or Cambridge, is chosen yearly by the heads of colleges, and no one can be chosen a second time. The series of lectures began in 1780, and has continued to the present time unbroken, with the exception of the years 1834 and 1835, when no lecturers were appointed, and 1841, when no lectures were delivered. Several of the lecturers have been men of great eminence and ability; Heber, for instance, was selected in 1815, Whately in 1822, Milman in 1827, Horne in 1828, Hampden in 1832, Goulburn in 1850, Mansel in 1856, Liddon in 1866. The institution has done much to preserve, at least in some quarters, a high standard in English theology; and the lectures as a whole form a very valuable body of apologetic literature.

**BANANA** (*Musa sapientum*), a gigantic herbaceous plant belonging to the natural order *Musaceæ*, originally a native of the tropical parts of the East, but now cultivated in all tropical and sub-tropical climates. It forms a spurious kind of stem, rising 15 or 20 feet by the sheathing bases of the leaves, the blades of which sometimes measure as much as 10 feet in length by 2 feet across. The stem bears several clusters of fruit, which somewhat resemble cucumbers in size and form; it dies down after maturing the fruit. The weight of the produce of a single cluster is sometimes as much as 80 lb, and it was calculated by Humboldt that the productiveness of the banana as compared with wheat is as 133 to 1, and as against potatoes 44 to 1. The varieties of banana cultivated in the tropics are as numerous as the varieties of apples in temperate regions, and the best authorities now agree that no specific difference exists between it and the plantain. The fruit is extensively used as food; and in many of the Pacific islands it is the staple on which the natives depend. In its immature condition it contains much starch, which on ripening changes into sugar; and as a ripe fruit it has a sweet but somewhat flavourless taste. From the unripe fruit, dried in the sun, a useful and nutritious flour is prepared. The following represents the percentage composition of the pulp of the ripe fruit:—Nitrogenous matter, 4·820; sugar, pectin, &c., 19·657; fatty matter, 0·632; cellulose, 0·200; saline matter, 0·791; water, 73·900. An analysis of the flour by Dr Murray Thomson yielded the following results:—Water, 12·33; starch, 71·60; gum and sugar, 6·82; nitrogenous matter, 2·01; cellulose, 5·99; oil, 0·50; salts, 0·64.

**BANAT**, a district in the south-east of Hungary, consisting of the three counties of Thorontal, Temeswar, and Krasso, which has strangely acquired this title, though it was never governed by a "ban." It is bounded by the Theiss, the Maros, and the Danube, forming almost a regular parallelogram. The soil is in many parts a remarkably rich alluvial deposit. Under the Turkish yoke it was allowed to lie almost desolate in marsh and heath and forest; but Joseph II. determined to render it, if possible, a populous and prosperous district. He accordingly offered land, at a very low rate, to all who were willing to settle within its borders. Germans, Greeks, Turks, Servians, Italians, and Frenchmen responded to his call, and soon developed the agricultural resources of the region. Canals were formed at great expense of labour; marshes and forests were cleared; and now the Banat is one of the most highly cultivated parts of the Austrian empire. Wheat, barley, oats, rye, rice, maize, flax, hemp, rape, sun-flowers, tobacco, grapes, and, in short, nearly all the productions of Europe, are successfully raised. The climate in summer is very like that of Italy, and in winter is milder than in other parts of Hungary. Nor is it any longer unhealthy, though, in 1777, Born spoke of it with horror as a realm of death, and the account given of it in 1802 by Dr Samuel Clarke was not much better. The scenery is extremely diversified, from the plains of Thorontal to the snowy mountains of Krasso. The mineral wealth is considerable, including copper, tin, lead, zinc, iron, and especially coal. Among its numerous mineral springs the most important are those of Menadia, which were known to the Romans as *Therma Herculis*. Not only there but in other parts of the Banat numerous remains of the Roman occupation still exist. The various origin of its inhabitants may still be easily traced,—the separate settlements having kept remarkably distinct, and in many cases preserving their native languages and customs. The chief town is Temeswar, and other places of importance are Jugos, Kikinda, Becskereh, and Werschitz. Population about 1,500,000.

See Griselin, *Versuch einer Gesch. des Temeswar Banats*, Vienna, 1785; Hitzinger, *Versuch einer Statistik der Mühlengrenze des Oesterreich. Kaiserth.*, Vienna, 1781; Böhm, *Geschichte des Temeswar Banats*, Leipzig, 1861; Paget, *Hungary*, 1855.

**BANBRIDGE**, a town of Ireland, county of Down, on the Bann, 23 miles S.W. of Belfast, standing on the summit of an eminence. To facilitate access, a central carriage-way, 200 yards long, has been cut through the main street to a depth of 15 feet, the opposite terraces being connected by a bridge. Banbridge is a neat town, with a handsome church, several chapels, a market-house (built in 1831), and a court-house. It is the principal seat of the linen trade in the county, and has extensive cloth and thread factories, bleachfields, and chemical works. Population in 1871, 5600.

**BANBURY**, a market-town, municipal and parliamentary borough, and railway junction, in the county of Oxford, 71 miles from London, and a little to the west of the River Cherwell and the Oxford and Birmingham canal. It is well built, and has two or three foundries, several breweries, and some other manufactures, but is chiefly dependent on the neighbouring villages which send their agricultural produce to its market. It was formerly famous for its cheese, and gives its name to a kind of cheese of considerable repute. Its ancient cross, now destroyed, is celebrated in the well-known nursery rhyme. During the 17th century the inhabitants of Banbury seem to have been zealous Puritans, and are frequently satirized by contemporary dramatists (Cham-



Banbury Arms

bers' *Book of Days*, vol. ii. p. 316). At a somewhat earlier period the grammar school, which is now defunct, was of such repute as to be chosen as the model for the constitution of the school of St Paul's. A school of science was erected in 1861. Banbury returns one member to parliament, and the borough (which is partly in Northamptonshire) had, in 1872, a population of 11,726, of whom 4122 were in the town.

**BANCA, BANKA, or BANGKA**, an island off the east coast of Sumatra, and separated from it by the Strait of Banca, lies between lat. 1° 30' and 3° 7' S., and long. 105° 9 and 106° 54' E. It varies from 8 to 20 miles in breadth, and has an area of 5000 English square miles. Its mines of tin, which were discovered in 1710, are remarkably productive, and in 1872 yielded no less than 68,148 piculs, the average yield during the previous ten years being 73,961 piculs. The washing is almost wholly carried on by Chinese, and a large part of the metal finds its way to their country. Iron, copper, lead, silver, and arsenic, are also found in the island. The soil is generally dry and stony, and the greater part of the surface is covered with forests, in which the logwood tree especially abounds. Its mountains, which scarcely exceed 2000 feet in height, are covered with vegetation to their summits. They are of granitic formation, containing felspar, quartz, mica, and tourmaline. Population, 54,339, including 17,070 Chinese, 37,070 natives, 116 Europeans, and 56 Arabs. Muntak, the capital, has upwards of 3000 inhabitants. "The houses, which mostly belong to Chinamen, are neatly built and well painted; the streets are kept in good repair, and the whole place has an air of enterprise and thrift" (*vide Bickmore's East Indian Archip.*, 1868). There are several other forts on the island. It belongs to the Dutch, who derive from it upwards of 3,000,000 guilders, or £250,000, of annual income, after the expenses of the administration are paid.

**BANCROFT, RICHARD**, Archbishop of Canterbury in the reign of James I., distinguished as an inflexible opponent of Puritanism, was born at Farnworth in Lancashire in 1544. He was educated at Cambridge University, studying first at Christ's College, and afterwards at Jesus College. He took his degree of B.A. in 1567, and that of M.A. in 1570. Ordained about that time, he was named chaplain to Dr Cox, then bishop of Ely, and in 1575 was presented to the rectory of Teversham in Cambridgeshire. The next year he was one of the preachers to the university, and in 1584 was presented to the rectory of St Andrew's, Holborn. His unquestionable abilities, and his zeal as a champion of the church in those unsettled times, secured him rapid promotion, and at length the highest ecclesiastical position in the land. He graduated B.D. in 1580, and D.D. five years later. In 1585 he was appointed treasurer of St Paul's Cathedral, London. On February 9, 1589, he preached at Paul's Cross a sermon on 1 John iv. 1, the substance of which was a passionate attack on the Puritans. He described their speeches and proceedings, caricatured their motives, denounced the exercise of the right of private judgment, and set forth the divine right of bishops in such strong language that one of the queen's councillors held it to amount to a threat against the supremacy of the Crown. Sixteen days after the publication of this ecclesiastical manifesto, Bancroft was made a prebendary of St Paul's. Within a few years he was advanced to the same dignity in the collegiate church of Westminster, and in the cathedral church of Canterbury. He was chaplain successively to Lord Chancellor Hatton and Archbishop Whitgift. In May 1597 he was consecrated bishop of London; and from this time, in consequence of the age and incapacity for business of Archbishop Whitgift, he was virtually invested with the power of primate, and had the sole management of



ecclesiastical affairs. Among the more noteworthy cases which fell under his direction were the proceedings against Martin Mar-Prelate, Cartwright and his friends, and the pious Peary, whose "seditious writings" he caused to be intercepted and given up to the Lord Keeper. In 1600 he was sent on an embassy, with others, to Embden, for the purpose of settling certain matters in dispute between the English and the Danes. This mission, however, failed. Bishop Bancroft was present at the death of Queen Elizabeth. He took a prominent part in the famous confession of the prelates and the Presbyterian divines held at Hampton Court in 1604. By the king's desire he undertook the vindication of the practices of confirmation, absolution, private baptism, and lay excommunication; he urged, but in vain, the re-inforcement of an ancient canon, "that schismatics are not to be heard against bishops;" and in opposition to the Puritans' demand of certain alterations in doctrine and discipline, he besought the king that care might be taken for a *praying clergy*; and that, till men of learning and sufficiency could be found, godly homilies might be read and their number increased. In the capacity of a commissioner for ecclesiastical causes (1603), he advocated severe measures for the suppression of "heresy and schism," treating books against Episcopacy as acts of sedition, and persecuting their authors as enemies of the state. In March 1604, Bancroft, in consequence of the death of the primate, was appointed by royal writ president of Convocation then assembled; and he there presented for adoption a book of canons collected by himself. In the following November he was elected successor to Whitgift in the see of Canterbury. He had now but six years of life before him. He continued to show the same seal and severity as before, and with so much success that Lord Clarendon, writing in his praise, expressed the opinion that "if Bancroft had lived, he would quickly have extinguished all that fire in England which had been kindled at Geneva." In 1605 he was sworn a member of the Privy Council. The same year he engaged in a contest with the judges, and exhibited articles of complaint against them before the lords of the council; but these complaints were overruled. He enforced discipline and exact conformity within the church with an iron hand; and forty-nine ministers of the church were deprived of their livings for disobedience to his injunctions. In 1608 he was chosen chancellor of the University of Oxford. One of his latest public acts was a proposal laid before the parliament for improving the revenues of the church. In the last few months of his life he took part in the discussion about the consecration of certain Scottish bishops, and it was in pursuance of his advice that they were consecrated by several bishops of the English Church. By this act were laid the foundations of the Scottish Episcopal Church. Archbishop Bancroft was "the chief overseer" of the authorised version of the Bible, published within a year of his death. He died at Lambeth Palace, November 2, 1610. His literary remains are very few and unimportant.

**BANDA**, a district of British India, in the Alláhábád division, under the Lieutenant-Governor of the North-Western Provinces, lies between 24° 59' 15" and 25° 55' 30" N. lat., and 80° 2' 45" and 81° 38' E. long. It is bounded on the N. by the district of Fathipur, from which it is separated by the River Jamná; on the N.E. by the districts of Fathipur and Alláhábád; on the S.E. by the native state of Riwá; on the S. and S.W. by some of the petty states of Bundelkhand; and on the W. and N.W. by the district of Hamirpur. Area, 3030 square miles, of which 1390 are under cultivation, 848 cultivable but not cultivated, 108 revenue free, and 684 uncultivable waste. The census of 1872 took the area at 2908.68 square miles, and returned the district population at 697,610 souls,—

viz., Hindus, 657,107; Mahometans, 40,497; Christians, 6. Average density, 230 persons to the square mile. Of the population in 1872, 2897 were landed proprietors, 42,230 agriculturists, and 63,644 non-agriculturists. In some parts the district rises into irregular uplands and elevated plains, interspersed with detached rocks of granite; in others it sinks into marshy lowlands, which frequently remain under water during the rainy season. The sloping country on the bank of the Jamná is full of ravines. To the S.E. the Vindhya chain of hills takes its origin in a low range not exceeding 500 feet in height, and forming a natural boundary of the district in that direction. The principal river of the district is the Jamná, which flows from north-west to south-east, along the N.E. boundary of the district for 125 miles. Its most important tributaries within the district are the Ken, Bágain, Paisuni, and Ohán, all of which take their rise in the Vindhya hills. The principal towns and market villages in the district are Mau, Májhgáon or Rájápur, Marká, Samgará, Angáat, Chhillá, and Barágotan, all situated on the bank of the Jamná.

The black soil of the district yields abundant crops of wheat, barley, maize, millet of various sorts, rice, and pulses. Hemp, oil-seeds, sugar, and indigo are also grown, but by far the most important crop is cotton, for which the district is so celebrated that the produce is distinguished in commerce as "Bándá Cotton." The estimated acreage under the principal crops—Gram (*Cicer arvensis*), 128,662 acres; wheat, 154,247; maize, 128,198; cotton, 69,667; barley, 60,976; rice, 20,987; total, 550,737 acres, or 860.52 square miles. The total cultivated area of the district is returned at 1390 square miles. The manufactures of Bándá consist of coarse cotton-cloth, sackcloth, and stone handles for knives. Iron and building stone form the only mineral products. The revenue of the district amounted in 1870-71 to £167,488, the expenditure being 263,425. Since the acquisition of the country by the British, eight settlements of the land revenue have been made at different periods. The last (1834-35) of these adjusted the demand at £184,004, and the total collections amounted in 1870-71 to £121,275. In 1871 the regular police force of 620 men was maintained at a cost of £2920, while a rural constabulary of 2552 men was maintained at the cost of the landholders and villagers. In 1871-72 there were 214 schools in the district, with an average daily attendance of 4695 pupils; expenditure, £2194, of which Government paid £754. Bándá district has only two towns containing upwards of 5000 inhabitants, viz., Bándá (37,746) and Girwán (6670). Bándá, the headquarters of the district, lies on the right bank of the River Ken, in lat. 26° 28' long. 80° 23'. Thirty-six miles of the Jalalpur branch of the East Indian Railway lie within the district, and eleven first-class roads afford good means of communication—the most important road, both commercially and for military purposes, being that from Mánikpur to Ohillá. The climate of Bándá is cold in the winter months, and terribly hot in summer. Frost is rare, except in the moist land adjoining the rivers; the hot winds frequently cause deaths among the natives from exposure to the mid-day heat. Rainfall in 1870-71, 51.3 inches.

Bándá has formed an arena of contention for the successive races who have struggled for the sovereignty of India. Kalinjár town, then the capital, was unsuccessfully besieged by Mahmud of Ghazni in 1023 A.D.; in 1196 it was taken by Kutub-ud-din, the general of Muhammad Ghori; in 1545 by Sher Shah, who, however, fell mortally wounded in the assault. About the year 1735 the Rájá of Kalinjár's territory, including the present district of Bándá, was bequeathed to Rájá Báo, the Marhattá Peshwá; and from the Marhattas it passed by the treaties of 1802-3 to the Company.

**BANDA ISLANDS**, a group in the East Indian Archipelago, lying to the S. of Ceram, in lat. 4° 30' S. and long. 129° 50' E. They are ten or twelve in number, and have an area of about 7150 square miles. Their volcanic origin is distinctly marked. Banda Lantoir, which derives its name from the *lontar* or Palmyra palm, is the largest of the group. From the sea this island appears lofty,—its sides being steep, and crowned by a sort of table-land which extends nearly from one end to the other. The whole is one continuous forest of nutmeg and *Casari* trees, the latter being planted to screen the former from the wind. The unhealthiness of Lantoir has prevented it from becoming the seat of government, for which in other respects it would naturally be chosen. The village of Salam contains the ruins of the chief Portuguese settlement. A considerable

Fort, called Hollandia, commands the harbour. Banda Neira lies S. of Lantoir. It is the seat of the Dutch resident, whose jurisdiction extends not only over the Banda Islands, but also over a part of Ceram and several other small groups. Fort Nassau, which was built in 1609, is the chief defence of the islands; and to the right and left of it extends the village of Neira. Gunong Api is to the north of Neira, and derives its name—Fire Mountain—from its large cone-shaped volcano, which rises 2320 feet above the level of the sea, and is constantly emitting smoke. The peak was ascended by Professor Reinwardt in 1821, by M. S. Müller in 1828, and in 1865 by Mr Rickmore, who has given an interesting account of the adventure. Eruptions took place in 1586, 1598, 1609, 1615, 1632, 1690, 1696, 1712, 1765, 1775, 1778, 1820, 1824; and earthquakes without eruptions occurred in 1629, 1683, 1710, 1767, 1816, and 1852. On the last occasion the sea swept up in an enormous wave over Fort Nassau. Pulo Way—The Water Island—lies north of Neira. It is about 400 or 500 feet high, consists of coral rock, and is esteemed the healthiest of the group. Pulo Rond or Roon—the Chamber Island—is about four miles further N., and was at one time the seat of an English "factory." Rosyngain, about seven miles S.E. of Lantoir, is likely to become of some importance for its gold-mines. It was formerly a convict station for Amboyna. Pulo Pisang—Banana Island—two miles N.E. of Neira, produces fine fruits. The other islands Craka, Capella, Sonangy, &c., are uninhabited. In the space between Banda Lantoir and the islands of Banda Neira and Gunong Api there is a very good harbour, formed with entrances both from the E. and W., which enable vessels to enter it from either of the monsoons. These channels are well defended with several batteries, particularly the western one, which is very narrow. Between Gunong Api and Banda Neira there is a third channel into this harbour from the N., but it is navigable for small vessels only. The principal articles of commerce in the Banda group are nutmegs and mace. The native population having been cleared off by the Dutch, the plantations were worked by slaves and convicts till the emancipation of 1860. The introduction of Malay and Chinese labourers has since taken place. The plantations or *perken* can neither be sold nor divided. About 700,000 lb or upwards of nutmegs are obtained in a year, with a proportionate quantity of mace. The imports are provisions, cloth, and iron-ware from Batavia, and various native productions from the Aru Islands, Ceram, &c.

The Banda Islands were discovered and annexed by the Portuguese Abrens about 1511; but in the beginning of the 17th century his countrymen were expelled by the Dutch. In 1608 the English built a factory on Pulo Way, which was demolished by the Dutch as soon as the English vessel left. Shortly after, however, Banda Neira and Lantoir were resigned by the natives to the English, and in 1620 Pulo Roon and Pulo Way were added to their dominions; but, in spite of treaties into which they had entered, the Dutch attacked and expelled their British rivals. In 1654 they were compelled by Cromwell to restore Pulo Roon, and to make satisfaction for the massacre of Amboyna; but the English settlers not being adequately supported from home, the island was retaken by the Dutch in 1664. They retained undisturbed possession of their conquests in this quarter of the globe until the year 1796, when the Banda Islands, along with all the other Dutch colonies, were conquered by the British. They were restored by the treaty of Amiens in the year 1800, again captured, and finally restored by the treaty of Paris concluded in 1814. In the Presidency of Banda there are 111,194 inhabitants, of whom 6000 belong to Neira.

See Wallace's *Malay Archipelago*; Blakmore's *Indian Archipelago*; Linden's *Banda on Zifis bewoners*, 1878; *Trans. of Dutch Geog. Soc.*, 1874.

BANDELLO, MARTEO, an Italian novelist, was born at Castellunovo, near Tortona, about the year 1480. He received a very careful education, and entered the church, though he does not seem to have prosecuted his theological course with great zeal. For many years he resided at Mantua, and superintended the education of the celebrated Lucrezia Gonzaga, in whose honour he composed a long poem. The decisive battle of Pavia, which gave Lombardy into the hands of the emperor, compelled Bandello to fly; his house at Milan was burnt and his property confiscated. He took refuge with Cesar Fregoso, an Italian general in the French service, whom he accompanied into France. In 1550 he was raised to the bishopric of Agen, a town in which he resided for many years before his death in 1562. Bandello wrote a number of poems, but his fame rests entirely upon his extensive collection of *Novelle*, or tales, which have been extremely popular. They belong to that species of literature of which Boccaccio's *Decameron* and the queen of Navarre's *Heptameron* are, perhaps, the best known examples. The common origin of them all is to be found in the old *Fabliaux* of the French Trouveurs, though some well known tales are evidently Eastern, and others classical. Bandello's novels are esteemed the best of those written in imitation of the *Decameron*, though Italian critics find fault with them for negligence and inelegance of style. They have little value in a purely literary point of view, and many of them are disfigured by the grossest obscenity. Historically, however, they are of no little interest, not only from the insight into the social life of the period which they afford, but from the important influence they exercised on the Elizabethan drama. The stories, on which Shakespeare based several of his plays, were supplied by Bandello, probably through Belleforest or Paynter (see Simrock, *Quellen des Shakespeare*). The same is true of Massinger, Beaumont and Fletcher, and others. The most convenient edition of Bandello is that in 9 vols., 1813.

BANDINELLI, BARTOLOMEO or BACCIO, a Florentine sculptor, was born in 1487, and died 1559. His father was an eminent goldsmith, distinguished for his exquisite designs in chasing gold and silver ornaments; and in this domestic school Bandinelli obtained the first elements of drawing. Showing a strong inclination for the fine arts, he was early placed under Rustici, a sculptor, and a friend of Leonardo da Vinci, with whom he made rapid progress. The ruling motive in his life seems to have been jealousy of Michel Angelo, one of whose cartoons he is said to have torn up and destroyed. Vasari, who gives a very full history of his life, manifests the greatest dislike for his moral character, but at the same time gives him the highest praise as an artist. He is regarded by some as inferior in sculpture only to his great rival, Michel Angelo; at all events, his productions entitle him to a very high place among Italian sculptors. His best works are the marble colossal group of Hercules and Cacus in the Piazza del Gran Duco; his group of Adam and Eve; his exquisite *bassi-relievi* in the choir of the cathedral of Florence; his copy of the Laocoon; and the figures of Christ and Nicodemus on his own tomb. (See Vasari, *Lives*, iii. 232-296.)

BANDINI, ANGELO MARIA, an Italian author, was born at Florence on the 25th Sept. 1726. Having been left an orphan in his infancy, he was supported by his uncle, Joseph Bandini, a lawyer of some note. He received his education among the Jesuits, and showed a special inclination for the study of antiquities. His first work was a dissertation, *De Veterum Sallustianibus*, published in 1749:

In 1747 he undertook a journey to Vienna, in company with the bishop of Volterra, to whom he acted in the capacity of secretary. He was introduced to the emperor, and took the opportunity of dedicating to that monarch his *Specimen Litteraturæ Florentinæ*, which was then printing at Florence. On his return he took orders, and settled at Rome, passing the whole of his time in the library of the Vatican, and in those of the Cardinals Passionei and Corsini. The famous obelisk of Augustus, at that time disinterred from the ruins of the Campus Martius, was described by Bandini in a learned folio volume *De Obelisco Augusti*. Shortly after he was compelled to leave Rome on account of his health and returned to Florence, where he was appointed librarian to the valuable library bequeathed to the public by the Abbé Marucelli. In 1756 he was preferred by the emperor to a prebend at Florence, and appointed principal librarian to the Laurentian library. During forty-four years he continued to discharge the duties of this situation, and died in 1800, generally esteemed and regretted. On his deathbed he founded a public school, and bequeathed the remainder of his fortune to other charitable purposes. The most important of his numerous works are the *Catalogus Codd. MSS. Græc., Lat., Ital., Bib., Laurent.*, 8 vols., 1767-1778, and the *Vita e Lettere d'Amerigo Vesputi*, 1745.

**BANDON**, or **BANDONREDON**, an inland town and parliamentary borough of Ireland, in the county of Cork, and twenty miles by rail from the county town, is situated on both sides of the River Bandon, which is here crossed by a bridge of six arches. It has two churches, a handsome Roman Catholic chapel, Protestant and Methodist places of worship, a convent, two market-houses, a spacious quay on the south side of the river, an infirmary, a hospital, a dispensary, several public libraries and reading-rooms, an endowed school, a court-house, a bridewell, and barracks. Its manufactures of woollen and cotton goods have much declined; but there are distilleries, breweries, tanneries, and flour-mills. Population in 1871, 6131.

**BANFF**, the county town of Banffshire, is a place of great antiquity; according to tradition, it was at times the residence of Malcolm Canmore. It was visited by David I. and his son Henry; and there is a charter of Malcolm IV., signed at Banff the eleventh year of his reign, which corresponds with 1163. The church was given to the monastery of Arbroath by William the Lion, and a convent of Carmelite or White Friars is mentioned in a charter by Robert I., 1324. The town is said to have lost many of its ancient grants, but these, it is added, were renewed in 1324 by King Robert the Bruce, and in 1373 by Robert II. The natural situation of the town is beautiful, having its south-eastern exposure on a gentle slope, the wide blue sea on its N., the River Deveron on the E., and on the S. the richly-wooded country with the magnificent mansion and grounds of the earl of Fife. The streets are well and regularly built and paved, and are remarkable for their cleanliness. The principal buildings are Banff Castle, a plain modern building, belonging to the earl of Seafield, erected upon the site of an old castle, in which Archbishop Sharp was born; the county court buildings; the town-house, surmounted by a spire 140 feet high; a prison; parish church, Episcopal church and parsonage, Free church, United Presbyterian, Independent, Methodist, and Roman Catholic places of worship; Chalmers' Hospital; a mason lodge, of tasteful architecture; the academy, a modern edifice of Grecian design, capable of containing 600 scholars, to which there is attached an extensive museum. There are large and well-conducted seminaries for young ladies, also several libraries, a club-room, branch banks and a savings-bank, public baths, hotels, custom-house, gas and water works, &c.

The *Banffshire Journal*, a weekly newspaper, with an extensive circulation, is published on Tuesdays. At one period Banff carried on a considerable manufactory of stockings and linen yarn. A branch of the Great North of Scotland Railway, which leaves Inverness Junction and terminates at Macduff, is the direct communication from Aberdeen, and has a station at Bridge of Banff. Another line of railway, which has its terminus at the harbour of Banff, runs in connection with Portsoy, and joins the Great North of Scotland Railway at Grange, near Keith. The principal exports are grain, cattle, salmon, herrings, haddocks, pork, butter, and potatoes. The river fishing is the property of the earl of Fife, with a sea-line extending a considerable distance on each side of the river mouth. The burgh is under the jurisdiction of a provost, three bailies, and five councillors, who manage all the town's affairs. Mr Alexander Cassie of London, a native of Banff, some thirty years ago, left to the poor of the town about £20,000, the interest of which is divided twice a year among the poor. A few years ago, Mr Alexander Chalmers of Clunias, a general merchant and shipowner in Banff, left about £70,000 to build and endow a hospital for sick and destitute. The building, which is near the harbour, has somewhat the appearance of Donaldson's Hospital at Edinburgh.

The town of Macduff, which is fast rising into importance, has a good harbour, branch banks, &c. It is about a mile to the E. of Banff, with which it has communication by a stone bridge of seven arches across the Deveron. Its trade in shipping, &c., is more extensive than that of Banff, to which burgh it was united by the Reform Act. It was an old burgh of barony, called Doune, but soon after it was acquired by the Duff family its name was changed to Macduff. A harbour was then erected, and in 1783 it was made a burgh by George III. Macduff is locally situated within the parish of Gamrie, and has an independent municipal government. Banff and Macduff unite with Elgin, Cullen, Inverurie, Kiptore, and Peterhead, in sending a member to parliament. Population within the parliamentary boundaries in 1871, about 4000; municipality, 3557. The weekly market-day of Banff is Friday, on which day a corn market is held; and there are two annual fairs.

**BANFFSHIRE**, a maritime county in the N.E. of Scotland, lying between lat. 57° 6' and 57° 42' N., and long. 2° 15' and 3° 40' N., and bounded on the N. by the Moray Firth, E. and S. by Aberdeenshire, and W. by Morayshire and part of Inverness-shire. It has an area of 686 square miles, or 439,319 statute acres, its extent from N. to S. being 50 miles, and from E. to W. 32 miles,—its average breadth not exceeding 14 miles. It contains 21 parishes, and parts of 10 others. Its royal and parliamentary burghs are Banff, Macduff, Cullen; and its principal harbours are at Banff, Macduff, Cullen, Portsoy, Buckie, and Portgordon. The parliamentary burghs are contributory to Elgin, and the county returns a member to parliament. The parliamentary constituency in 1874-5 was 1737. Many of the schoolmasters, with those of the counties of Aberdeen and Moray, share in Dick's bequest.

The surface of Banffshire presents a very diversified aspect. The lower district is mostly a fine open country of a rich, deep, and highly-cultivated soil, agreeably diversified with gentle risings and young plantations. The upper district is mountainous and, at a distance, wears a bleak, forbidding appearance. But the scene changes on a nearer approach. Extensive farms are found embosomed in its fertile and well-cultivated glens. Some of the mountains are covered with trees in full luxuriance of growth; some presenting a beautiful intermixture of rock and copse, while others are covered with brown heath. The Spey flows along its western, and the Deveron along its eastern boundary; and both yield a considerable revenue from their salmon-fish-

ings. The principal mountains of Banffshire proper are Benrinnes and the Knockhill; but Cairngorm, Ben Macdui, and Ben Aven, the highest summits in Britain, lie on or close to the boundary. The principal noblemen's and gentlemen's seats are Duff House, Cullen House, Park House, Troup House, Forglie House, Drummuir, Kininvie, Balvenie, Aberlour, and Rothiemay. Several of these are elegant mansions, and most of them are surrounded by extensive and tastefully laid-out plantations. The natural woods are inconsiderable both in extent and value.

The geology of Banffshire is very closely connected with that of the neighbouring counties of Aberdeen and Moray, from which it is divided by no natural boundaries. Gneiss, and to a greater extent mica slate, form the lowest stratified rocks running nearly south-west from the coast between Cullen and Portsoy to the upper valleys of the Fiddach, Deveron, and Aven rivers. Generally they are fine grained slaty rocks, and form low rounded mountains, of no great beauty, but decomposing into soils of considerable fertility. In many places the mica slate alternates or passes into quartzite, which differs from it chiefly in the almost entire absence of mica. Quartzite in a more independent form is seen on the coast between Cullen and Buckie, and forms also the Durn Hill near Portsoy, the Binn of Cullen, the Knockhill, and much of the high ground to the south. Where it prevails the soil is far from fertile, and the white, weather-beaten mountains have a very sterile aspect. Connected with this series also beds of limestone are very common, and have been quarried in many places, as near Boyne Castle, Sandend, and Fordyce in the north, and in the interior near Keith, Mortlach, and Tomintoul.

Clay slate occurs in considerable abundance in Banffshire, in some places perhaps merely a finer variety of mica slate, in others coarser in texture, or so-called greywacke. Large masses are seen near Boharm, and from Duftown south to Kirkmichael. It also forms the north coast from Knock Head by Banff, Macduff, and Gamrie, to the Troup Head, often rising into bold, lofty cliffs, and extends south to Gartly. In several places it is wrought for roofing slates both in this county and in Aberdeenshire. Though no fossils have yet been found in these strata, there is little doubt that they are more or less metamorphosed representatives of the lower-ports of the Palaeozoic (Silurian and Cambrian) formations.

Resting on these rocks Devonian or Old Red Sandstone and conglomerate beds are seen in a few places. Thus the Morayshire beds cross the Spey near Fochabers, running along the coast to Buckie, and in the Tynet Burn have yielded many characteristic fossil fishes. Gamrie, at the north-east extremity of the county, is also well known for similar remains occurring in calcareous nodules embedded in a bluish grey marly rock, from which they are washed out by a small stream on its way to the sea. The more important species are *Cheiracanthus Murchisoni*, *Cheirolepis Uragus*, *Cocconeus cuspidatus*, *Diplopterus affinis*, *Glyptolepis elegans*, *Osteolepis arenatus*, and *Pterichthys Milleri*. In the interior, near Tomintoul, another large deposit of red sandstone occurs, probably of the same age, but as yet no organic remains have been found in this locality. Indications of still more recent formations are seen in the chalk flints common in the vicinity of Portsoy, and in the Oolite fossils found in the brick clays at Blackpots. The raised beach with recent shells, more than 200 feet above the sea-level, near the old church of Gamrie, is also interesting. As in other parts of Scotland, the surface of the country is covered with masses of boulder clay and stratified drift beds, the materials often derived from a considerable distance and some of the granite boulders several tons in weight.

The most important igneous rock is granite. This rock,

a portion of the great central mass of the Grampians, forms the mountains in the extreme south of the country round the sources of the Aven. Benrinnes also consists of it, and smaller masses are seen in Glenlivet and other localities. The well-known "graphic granite" forms a vein on the coast near Portsoy, and gets its name from the quartz and felspar crystals appearing on the polished surface like rude letters. Syenite, a compound of hornblende and felspar, covers a large district running south from near Portsoy to Rothiemay and Huntly in Aberdeenshire. The serpentine of Portsoy, though long known, and said to have been at one time extensively wrought and even sent to France as an ornamental stone, is now almost neglected. Rocks of a similar character may be traced pretty much in a south-west direction to near the sources of the Deveron, and from that into the upper parts of the Don in Aberdeenshire.

Some interesting minerals have been found in Banffshire. Among them may be mentioned magnetite, chromite, and asbestos at Portsoy; fluorite near Boharm, at Keith, and on the Aven; also cyanite and chialstolite in clay slate at Boharm. Attempts were made many years ago to work a vein of sulphuret of antimony near Keith; and more recently mines of hematite were opened near Armdilly on the Spey.

The agriculture of Banffshire is conducted upon the newest and most approved principles. The soil, though varying even in adjacent fields, is in general rich and productive, yielding fair crops of wheat, and excellent crops of barley, oats, &c.; and the grass and green crops are equally abundant. About 163,000 acres are under cultivation, the extent of the farms is in general from 150 to 200 arable acres, independently of moorland and pasture-grounds. The duration of leases is nineteen years; although there are still some individuals who possess on life rent, and a few leases are held for a longer term. The whole of the farms, even the smallest pendicles, are under regular rotations of cropping, generally a five or seven course shift. The fields are well laid out and subdivided, and properly cleaned and manured; for which last purpose large quantities of lime, bone-dust, and guano, are annually imported. The ridges are all straight; and the fields, at least many of them, are enclosed with stone dykes or other fences. The swamps and wet grounds have also been drained and cultivated, so as to effect a total revolution in the ancient modes of agriculture within the county. The cattle and stock hold a high character; and there are several herds of pure short-horns and pure polled Aberdeenshire cattle maintained in the county. This district was much indebted to one of the earls of Findlater, who, as early as the year 1754, not only introduced and exemplified, on some of his own farms, the most approved practices then known in England, but held out liberal encouragement to his tenants to follow his example. His descendants, the earls of Seafield, have also done much to improve the family estates, adding to them many thousands of acres of arable land; and it may be said with truth that one of the earls was the greatest planter of trees in Great Britain within the present century. In 1846 this nobleman received the honorary gold medal of the Highland and Agricultural Society of Scotland, for his vast and thriving plantations of useful timber trees, in the counties of Banff, Moray, and Nairn. From the year 1811 to 1845, he had planted 18,930,224 Scotch fir, 11,904,798 larches, 845,450 hardwoods; making the enormous aggregate of 31,686,472 forest trees, planted in 8223 acres of enclosed ground.

This county also owes much to the earls of Fife, by whose generous efforts and taste for improvement a vast amount has been done in planting and reclaiming land, by favourable leases to the tenantry, and allowances for draining, &c.

Lastly, improvement has been promoted by agricultural associations, annual premiums being given for the best specimens of live stock and the best productions of the soil. The Banffshire Agricultural Association has two shows yearly for all sorts of stock and produce and agricultural implements, with premiums for superiority in various breeds of cattle, poultry, &c. The valued rental of the county is now upwards of £224,250 sterling.

The manufactures of Banffshire are very unimportant, the inhabitants being principally engaged in agriculture and the rearing of cattle. The salmon-fishery is actively prosecuted on the rivers, and herring and other fisheries on the coast. Distilling is largely carried on in Glenlivet and other places; and there is a woollen factory at Keith.

Banffshire was the scene of many bloody conflicts between the Scots and their Danish invaders. From 1624 to 1645 it was the theatre of almost incessant struggles, and the Covenanted troubles of that period, combined with the frequent conflicts of the clans, were productive of serious evils. Several remains of antiquity are pointed out in different parts of the country, such as the sculptured stone at Mortlach, and the churches of Cullen and Fordyce. Ruins of castles and traces of encampments are often to be met with, and a great number of cairns and tumuli are also found. Among the distinguished men whom Banffshire has produced, the following may be mentioned:—Archbishop Sharp of St Andrews; George Baird, distinguished for his services as sheriff of the county during the time of the Covenanters; Thomas Ruddiman, the grammarian; Walter Goodall, the defender of Mary Queen of Scots; Dr Alexander Geddes; and James Ferguson, the astronomer. The population of the county in 1861 and in 1871 was as follows:—

	Houses			Persons		
	Inhabited.	Uninhab.	Building	Male	Female	Total.
1861	11,091	318	92	28,000	31,215	59,215
1871	11,603	370	80	29,367	32,656	62,023

See Robertson's *Collections for a History of the Shires of Aberdeen and Banff*; Spalding Club; Shaw's *History of the Province of Moray*; Cordner's *Antiquities of the North of Scotland*; and various statistical accounts of Banffshire.

**BANGALORE**, the administrative capital and most important town of the chief commissionership of Mysore, also a large military cantonment, situated in 12° 58' N. lat., and 77° 38' E. long. In 1872 the total population of the Bangalore municipality amounted to 191,300; municipal income in 1872-73, £19,090; expenditure, £17,496; average rate of taxation, 2s. per head of the population. For the protection of the town, a municipal police, consisting of 22 officers and 124 men, was maintained in 1872-73, at a total cost of £2756. Bangalore commands the province of Mysore from a military point of view. The elevation of the district on which it stands renders it healthy for English troops; and a large European and Native force is quartered at the military cantonment,—the Native force in 1872-73 consisting of six regiments of cavalry, numbering 2095 officers and men, and four regiments of infantry, numbering 2149 officers and men. The principal institution of the town is the Bangalore High School or Central College for the province, attended by between four and five hundred pupils. The average annual charge of educating each pupil in 1872-73 was £3, 4s. 6d. of which £2, 3s. 9d. was contributed by the state. Mr Thornton thus writes regarding the history of the town:—

The foundation of the present fort was laid by a descendant of Kempe-Gond, a husbandman of the neighbouring country, who, probably in the 16th century, had left his native village to avoid the tyranny of the *wadepary* of that place, and settled on a spot a few miles to the north of Bangalore. To the peaceful occupation of a farmer he added that of a warrior, and his first exploit was the conquest of this place, where, and at Savendrug, his family subsequently

erected fortresses. Bangalore, with other possessions, was, however, wrested from them by Bijapur. Somewhat later we find it enumerated among the *jadirs* of Shahji, father of Sivaji, the founder of the Marhatta sway; and at an early period of his career in the service of the Bijapur state, that adventurer seemed to have fixed his residence there. It appears to have passed into the possession of Venkoji, one of the sons of Shahji; but he having occupied Tanjor, deemed Bangalore too distant, especially under the circumstances of the times, to be safe. He accordingly, in 1687, entered into a bargain for its sale to Chik Deo, Rájá of Mysore, for three lacs of rupees; but before it could be completed, Kasim Khan, commander of the forces of Aurangzeb, marched upon the place, and entered it almost without resistance. This event, however, had no other result than to transfer the stipulated price from one vendor to another; for that general, not coveting the possession, immediately delivered it over to Chik Deo on payment of the three lacs. In 1768, Nanjiraj, the powerful minister of the Rájá, caused Bangalore to be granted, as a *jadir* or *fief* to Haidar Ali, afterwards usurper of Mysore, who greatly enlarged and strengthened the fort, which, in 1760, on his expulsion from Seringapatam, served as his refuge from destruction. In 1791 it was stormed by a British army commanded by Lord Cornwallis.

The subsequent history of Bangalore belongs to the general events of Mysore, the province of which it forms the political capital. Bangalore is now one of the handsomest English stations in India, with noble public buildings, spacious and artistically laid out gardens, broad smooth roads, well-supervised bazaars, and a good water supply. The markets display almost every sort of English and Indian fruit or vegetable. Bangalore forms the residence of the chief commissioner of Mysore and the principal officers of his administration, and is well worthy of its place as the political and military capital of the province.

**BANGKOK**, a city of Siam, which was raised to the rank of capital in 1769. It is situated on both sides of the River Menam, about 20 miles from the sea, in lat. 13° 38' N. and long. 100° 34' E. The river is navigable to the city for vessels of 350 tons, but there is a bar at its mouth, which at the lowest ebbs has only six feet of water, and at no time has more than fourteen. The general appearance of Bangkok is very striking, alike from its extent, the strange architecture of its more important buildings, and the luxuriant greenness of the trees with which it is profusely interspersed. The streets are in many cases traversed by canals, and the houses raised on piles, while a large part of the population dwell in floating houses moored along the river sides in tiers three or four deep. The nucleus of the city on the eastern bank is surrounded by a wall 30 feet high, and 10 or 12 feet thick, relieved by numerous towers and bastions; but the rest of the city stretches irregularly for full seven miles along each side of the river, and in some places attains nearly as great a breadth,—the Menam itself being about a quarter of a mile across. All the ordinary buildings are composed of wood or bamboo work; but the temples and palaces are of more solid construction, and are gorgeously ornamented. The spires, and in some cases the whole edifices, are covered with gilding, or many-coloured mosaic of the most grotesque description, while the roofs are adorned with fantastic ridges and gables. In all there are upwards of a hundred temples in the city and suburbs. The palace of the "First King" is enclosed by high white walls, which are about a mile in circumference. It consists of a large number of different buildings for various purposes—temples, public offices, seraglios, the stalls for the sacred elephant, and accommodation for thousands of soldiers, cavalry, artillery, and war elephants, an arsenal, a theatre, &c. The hall of audience, in which the throne of the king stands, is situated in the middle of the principal court. The temples are of great richness, floored with mats of silver, and stored with monuments and relics. In one of them is a famous jasper statue of Buddha. The population of the city is of various nationalities,—Burmese, Peguans, Cambodians, Cochinchinese, Malays, Indo-Portuguese, and others, besides the

two predominant classes, the Chinese and Siamese. There is great commercial activity, the principal articles of trade being sugar, pepper, and rice. The supplies of the last article can be brought from a long way inland by means of the river and various canals, such as the *Petric*, which joins the Bang-Pa-Kong at Kanat. Cardamoms, timber, and tin are also largely exported. European manufactures are extensively imported, the natives being very ready to adopt new methods and machinery; and steam-mills for various purposes are being set up. The river is kept clear by a steam-dredger, and iron bridges of European construction are built across the canals. Gas is used in the palaces of the kings and the houses of many of the nobility. A considerable number of European firms carry on business in the city, and the English Government maintains a consular Christian missions, both Protestant and Roman Catholic, are maintained, the latter church having established a bishopric. The population is said to amount to 400,000.

The reader will find much curious information on Bangkok in Crawford's *Embassy to Siam*, 2 vols. 1830 (plan at p. 214 of vol. ii.); Pallegoix's *Description du royaume Thai, ou Siam*, 1854; and Bowring's *Siam*, 1857. See also *Jahresbericht des Vereins für Erdk. zu Dresden*, viii. and ix.

**BANGOR**, a parliamentary borough and market-town of Carnarvonshire, North Wales, nine miles N.E. of Carnarvon, to which it is a contributory borough. It consists mainly of one narrow crooked street of nearly a mile in length, stretching N.E. and S.W. through a romantic valley between two ridges of rock. It stands near the northern entrance of the Menai Strait, and the beauty of its scenery attracts thousands of visitors every year. The principal buildings are the cathedral, episcopal palace, deanery-house, Roman Catholic chapel, several dissenting meeting-houses, free schools, union poorhouse, infirmary, market-house (1862), assembly rooms, temperance hall, three banks, and railway station. The cathedral is an embattled cruciform structure, with a low massive tower crowned with pinnacles. It occupies the site of a more ancient edifice, originally founded about 525, but destroyed by the English in 1071. It was afterwards rebuilt, but suffered severely in the wars between the Welsh and Henry III.; and in 1402 it was burned down during the ravages of Owen Glendower. For more than ninety years it remained in ruins. The choir was rebuilt by Bishop Dean in the time of Henry VII., and the tower and nave were added by Bishop Skeffington in 1532. The principal trade of Bangor consists in the export of slates, which are raised in the quarries six miles distant, and conveyed by a railway to Port Penrhyn, at the mouth of the River Cegid, a little to the east of the town. This port is accessible for vessels of from 200 to 300 tons at all states of the tide, and has a quay upwards of 300 yards in length. Population of burgh in 1871, 9859.

**BANGOR**, a seaport and market-town of Ireland, county Down, on the south side of Belfast Lough, 12 miles E.N.E. of Belfast. It carries on a considerable trade in cotton and linen and embroidered muslin, and has a bank, a market-house, a parish church, several chapels, and a public library. It is greatly frequented as a bathing-place, especially by the people of Belfast. Remains of an ancient abbey, said to have been destroyed by the Danes in 820, are still to be seen. Population in 1871, 2560.

**BANGOR**, a seaport town in the state of Maine, North America, capital of the county of Penobscot, on the river of that name, at its junction with the Kenduskeag, 60 miles from the sea. Lat.  $44^{\circ} 47' 50''$  N., long.  $68^{\circ} 47'$  W. It was incorporated as a town in 1791, and raised to the rank of a city in 1834. The harbour is spacious, and affords anchorage for the largest vessels at high tide. The chief article of trade is timber, which employs about 2000 ships annually; and there are saw-mills, planing-mills,

ship-yards, foundries, and manufactories of furniture. There are numerous good schools arranged on a graduated scale, and churches of about ten different denominations. A theological seminary belonging to the Congregationalists was founded in 1816. A library, instituted in 1843, has upwards of 11,000 volumes. Population in 1870, 18,289.

**BANIALUKA**, a town and fortress of Turkey, in the eyalet of Bosnia, situated on the Verbas or Verbitza, a navigable tributary of the Save. Its warm baths, for which it is still known, would seem, from the antiquities discovered on the spot, to have been frequented by the Romans. There are upwards of forty mosques in the town, and one of them is regarded as the finest in Turkey. An active trade is carried on, and gunpowder and cloth are manufactured, while in the neighbourhood silver-mining is also prosecuted with success. Banialuka was for a long time the seat of the Bosnian governors, and has been frequently exposed to the vicissitudes of war. In 1688 it was captured for the Austrians by Louis of Baden. Population, 15,000.

**BANIM, JOHN**, an Irish novelist of great power and ability, was born at Kilkenny in 1798. He received a good education, and at a very early age gave evidence of remarkable genius. In his thirteenth year he entered Kilkenny College, where many other eminent Irishmen have received their training, and devoted himself specially to drawing and painting, in which he became so proficient that he resolved to adopt the profession of an artist. He accordingly proceeded to Dublin and studied for two years in the schools connected with the Royal Society, where he obtained high prizes. For some time afterwards he taught drawing in his native town, and while doing so had the misfortune to fall violently in love with one of his pupils. His affections were returned, but the parents of the young lady interfered and removed her from Kilkenny. She pined away and died in two months. The occurrence made a deep impression on Banim's mind, and this, together with his exposure to the weather on the night of her funeral, caused a severe illness which completely shattered his health. After a partial recovery he set out for Dublin and settled finally to the work of literature. He published a poem, *The Celtic Paradise*, and had some success as a writer for the stage. During a short visit to Kilkenny, he married, and at the same time planned, in conjunction with his brother Michael (born 1796), a series of tales illustrative of Irish life. He then set out for London, the great centre of literary activity, and supported himself by writing for magazines and for the stage. A volume of miscellaneous essays was published anonymously in 1824, called *Revolutions of the Dead Alive*. In April 1825 appeared the first series of *Tales of the O'Hara Family*, which achieved immediate and decided success. One of the most powerful of them, *Crohoore of the Bull Hook*, was by Michael Banim. In 1826 a second series was published, containing what is decidedly one of the best Irish novels in our literature, *The Nowlans*. John's health had almost entirely given way, and the next effort of the "O'Hara family" was almost entirely the production of his brother Michael. *The Croppy*, a Tale of 1798, is hardly equal to the earlier tales, though it contains some wonderfully vigorous passages. *The Demouréed*, *The Mayor of Windgap*, *The Ghost Hunter* (by Michael Banim), and *The Smuggler*, followed in quick succession, and were received with considerable favour. Banim, meanwhile, had completely broken down in health, and had become much straitened in circumstances. During his absence in France a movement to relieve his wants was set on foot by the English press, headed by Sterling in the *Times*. A sufficient sum was obtained to remove him from any danger of actual want, and to this Government afterwards added a pension

of £150. He settled in Windgap Cottage, a short distance from Kilkenny; and there, a complete invalid, he passed the remainder of his life. His last piece of literary work was the novel, entitled *Father Connell*. He died in July 1842, aged 44. Banim's true place in literature is to be estimated from the merits of the *O'Hara Tales*; his later works, though of considerable ability, are not unfrequently prolix, and are marked by too evident an imitation of the *Waverley Novels*. The *Tales*, however, show him at his best; they are masterpieces of faithful delineation. The strong passions, the lights and shadows of Irish peasant character, have rarely been so ably and truly depicted. The prevailing quality is a wonderful vehemence, combined with a gloominess extending at times to natural phenomena as well as to the characters of the tale; the incidents are striking, sometimes even horrible, and it is not without some justice that the authors have been accused of *sensationalism*, of straining after melodramatic effect. The lighter, more joyous side of Irish character, which appears so strongly in *Lover*, does not receive due prominence from the Banims. (See P. J. Murray, *Life of John Banim*, 1857.)

BANJARMASSIN, a district in the south-east of Borneo, which was incorporated by the Dutch in consequence of the war of 1860, in regard to the succession in the sultanate, which had been under their protection since 1787. It is watered by the river system of the Banjar, and traversed by a chain of mountains that in some places

reaches the height of 3000 feet. The district has been divided by the Dutch into the residency of Kween and the sub-residencies of Amuntal and Martapura. The town of Martapura was the seat of the sultan from 1771. The principal productions of the district are gold, diamonds, coal, pepper and other spices, drugs, edible birds' nests, gum, wax, rattans, &c. The inland portion is covered with forest, while the flat and swampy seaboard is largely occupied by rice-fields. The inhabitants, who are for the most part Dayaks, are roughly estimated from 300,000 to 600,000.

BANJARMASSIN, the chief town of the above district, also known as Fort Tatas, is situated about 15 miles from the mouth of the Banjar, in lat. 3° 23' S., long. 114° 37' E. The most of the houses are built on piles, as the town is subject to frequent inundations. In 1700 the East Indian Company established a factory here; but the place was found to be unhealthy, and the Company's servants were finally attacked by the natives, whom they repulsed with great difficulty. The settlement was abandoned. The English again seized Banjarmasin in 1811, but restored it in 1817. The trade consists in the export of the products of the surrounding country and the import of cloth, Chinese pottery, all kinds of metal goods, opium, tobacco, and salt. The population is of a very mixed character, and is estimated at upwards of 30,000. Of the commercial community the Chinese form a very important portion. The coal mines, discovered in 1846 at Mount Pengaron, to the E., are largely worked by the Dutch.

## BANKING

A BANK, in its simplest form, is an institution where money may be deposited for safe keeping; but banks are usually established to lend as well as to receive money; and the profits of a banker are commonly derived from the excess of the interest he receives from those indebted to him over the interest he allows, so far as he allows any, to those who have deposited money with him. Early denunciations of usury (Exod. xxii. 25) show the antiquity of the practice of lending money at interest; but this must have long preceded the origin of the business of both borrowing and lending money. When this first appeared it was not, at least in modern Europe, a distinct profession, but was undertaken by goldsmiths and dealers in precious metals. In the progress of the separation of employments, which is a characteristic of an advancing society, banking became a business of its own, which has again been subdivided into many branches independently pursued. It was, for example, formerly generally allowed to be part of the business of a banker to borrow money by issuing promissory notes payable to bearer, which passed from hand to hand as money, within the sphere of the operations of the banks, and banks thus borrowing money were called *Banks of Issue*; but it has been contended of late years that the function of issuing notes passing by delivery as money should be reserved for the state, or for some institution controlled and directed by the state; and we shall have hereafter to notice the controversy that has arisen on this point, and the steps that have been taken in consequence of it. An explanation of the different species of banks will also properly be deferred till a later stage, but it will be convenient here to give a general sketch of the nature of the business of an ordinary banker. We have said he receives and lends money; he may receive money either on a deposit or on a current or drawing account. When money is received on deposit it is commonly repayable to the depositor alone, to whom a deposit note or receipt is given; but it may also be paid to any one to whom the depositor gives an order on the bank either

endorsed on the deposit note or receipt or accompanying it. If the banker undertakes to pay interest on deposits, the rate varies according to the length of the notice the depositor agrees to give before withdrawing the money, the ability of the banker to deal with it being, of course, dependent upon the time he may rely upon keeping it. When money is received on a current or drawing account, the customer of the banker draws it out, as he requires, by means of orders, to which the specific name cheques is given; and, partly for convenience and partly by way of security against fraud, bankers are in the habit of giving their customers books of forms of cheques consecutively numbered. Cheques are generally payable to the person in whose favour they are drawn (the payee) or bearer, though they are sometimes payable to the payee or order, in which case endorsement by the payee is necessary before the money can be received. By the usage of bankers in the United Kingdom a "crossed" cheque, that is, a cheque across the face of which two parallel lines, with the name of a banker or the words "— & Co." inserted between them, have been drawn, has been long held payable by the banker on whom it is drawn to the payee alone or to another banker; and this usage received the force of law by statutes of the present reign (19 and 20 Vict. c. 25, and 21 and 22 Vict. c. 79).

Bankers lend money by opening credits in their books, against which their favoured customers may draw to the extent of the credits opened; by discounting bills; by the purchase of securities; or by advancing money on securities, &c., &c. It will have been gathered that they also undertake the business of collecting the money for cheques, for bills, and for other securities as they mature, which they may have received from their customers. The labour of collection is much facilitated in England by the fact that bills of exchange are almost invariably made payable in London, and that every country banker has a correspondent among the London bankers who collects for him and pays for him; and the London bankers again maintain an

establishment called the Clearing-house (see p. 328), where their clerks meet to effect their interchanges.

Banking appears to have reached a high state of development among the ancients. The bankers of Greece (*ρπαρδύρας*) and Rome (*argentarii, mensarii, nummularii*) exercised nearly the same functions as those of the present day, except that they do not appear to have issued notes. They received money on deposit, to be repaid on demands made by cheques or orders, or at some stipulated period, sometimes paying interest for it, and sometimes not. Their profits arose from their lending the balance at their disposal at higher rates of interest than they allowed the depositors. They were also extensively employed in valuing and exchanging foreign moneys for those of Athens, Corinth, Rome, &c., and in negotiating bills of exchange. In general they were highly esteemed, and great confidence was placed in their integrity. The rate of interest charged by the bankers was sometimes very high, but that was not a consequence, as has been alleged, of their rapacity, but of the defective state of the law, which, as it gave every facility to debtors disposed to evade payment of their debts, obliged the bankers to guarantee themselves by charging a proportionally high rate of interest.<sup>1</sup> Banking reappeared in Italy upon the revival of civilization. The bank of Venice is reputed the first in date in the history of modern Europe; but it did not become a bank, as we understand the term, till long after its foundation. Historians inform us that the republic being hard pressed for money, was obliged, upon three different occasions, in 1156, 1480, and 1510, to levy forced contributions upon the citizens, giving them in return perpetual annuities at certain rates per cent. The annuities due under the forced loan of 1156 were, however, finally extinguished in the 16th century; and the offices for the payment of the annuities due under the other two loans having been consolidated, eventually became the Bank of Venice.<sup>2</sup> This might be effected as follows:—The interest on the loan to Government being paid punctually, every claim registered in the books of the office would be considered as a productive capital; and these claims, or the right of receiving the annuity accruing thereon, must soon have been transferred, by demise or cession, from one person to another. This practice would naturally suggest to holders of stock the simple and easy method of discharging their mutual debts by transfers on the office books, and as soon as they became sensible of the advantages to be derived from this method of accounting, bank-money was invented. It will, however, be seen that the establishment thus described was at first no more than the transfer office of a National Debt, transfers of which were accepted at par in discharge of private debts, and it is indeed said that the funded debt transferred sometimes commanded an agio or<sup>3</sup> premium above the current money of the republic. This establishment was ruined, after passing through many changes, by the invasion of the French in 1797.

The origin of modern banking may be traced to the money-dealers of Florence, who were in high repute as receivers on deposit and lenders of money in the 14th century; and banking was indeed practised at Florence in the 13th if not in the 12th century. Mr Macleod writes (*Banking*, vol. i. 289)—

“The names of the Bardi, Acciajuoli, Peruzzi, Pitti, and Medici were famous throughout Europe. In 1345 the Bardi and the

Peruzzi, the two greatest mercantile houses in Italy, failed. Edward III. owed the Bardi 900,000 gold florins, which his war with France prevented him paying; and the king of Sicily owed them 100,000 gold florins. The deposits of citizens and strangers with the Bardi were 550,000 gold florins. The Peruzzi were owed 600,000 gold florins by Edward III., and 100,000 by the king of Sicily, and the deposits they owed their customers were 350,000 gold florins. The fall of these two great pillars of credit involved that of multitudes of other smaller establishments, and, says Villani (*istor. Fiorent.*, xii. 55), the community of Florence had never been thrown into such ruin and disorder before. And thereupon he breaks out against the folly of his fellow-citizens entrusting their money to the care of others for the love of gain. The city, however, recovered from this terrible disaster, and we find that between 1430 and 1433 seventy-six bankers at Florence lent 4,865,000 gold florins. At one time Florence is said to have had eighty bankers, but not any public bank.”

The business of banking was not introduced into England till the 17th century, when it began to be undertaken by goldsmiths in London, who appear to have borrowed it from Holland. It was attacked as innovations commonly are. Mr Gilbart, in his *History and Principles of Banking*, quotes, from a pamphlet published in 1676, entitled *The Mystery of the New-Fashioned Goldsmiths or Bankers Discovered*, a passage that may be reproduced,—

“Much about the same time—the time of the civil commotion—the goldsmiths (or new-fashioned bankers) began to receive the rents of gentlemen’s estates remitted to town, and to allow them, and others who put cash into their hands, some interest for it if it remained but a single month in their hands, or even a lesser time. This was a great allurements for people to put money into their hands, which would bear interest till the day they wanted it; and they could also draw it out by one hundred pounds or fifty pounds, &c., at a time as they wanted it, with infinitely less trouble than if they had lent it out on either real or personal security. The consequence was that it quickly brought a great quantity of cash into their hands, so that the chief or greatest of them was now enabled to supply Cromwell with money in advance, on the revenue, as his occasion required, upon great advantages to themselves.”

Sir Josiah Child also attacked “that innovated practice of bankers in London” in his *New Discourse of Trade*, though he subsequently became himself a banker; and his house, Messrs Child & Co., of Temple Bar, and the house of Messrs Hoare, in Fleet Street, still survive as the only private banks now in existence in London which were established previous to the Bank of England.

#### *Foundation and Early History of the Bank of England.*

The Bank of England, which has long been the principal bank of deposit and circulation in Great Britain, and indeed in Europe, was founded in 1694. Its principal projector, Mr William Paterson, an intelligent Scotch gentleman, was afterwards engaged in the ill-fated Darien enterprise. Government being at the time much distressed for want of money, partly from the defects and abuses in the system of taxation, and partly from the difficulty of borrowing because of the supposed instability of the Revolutionary establishment, the bank grew out of a loan of £1,200,000 for the public service. The subscribers, besides receiving 8 per cent on the sum advanced as interest, and £4000 a year as the expense of management, in all £100,000 a year, were incorporated into a society denominated the Governor and Company of the Bank of England. The charter is dated the 27th of July 1694. It declares, amongst other things, that they shall “be capable, in law, to purchase, enjoy, and retain to them and their successors, any moneys, lands, rents, tenements, and possessions whatsoever; and to purchase and acquire all sorts of goods and chattels whatsoever, wherein they are not restrained by Act of Parliament; and also to grant, demise, and dispose of the same.

“That the management and government of the corporation be committed to the governor and twenty-four direc-

<sup>1</sup> Boeckh’s *Political Economy of Athens*, i. 168, &c.; *Voyage d’Anacharsis*, cap. 55, *passim*; Smith’s *Dictionary of Greek and Roman Antiquities*, s. v. *Argentarii*, &c.

<sup>2</sup> The annuities of the forced loan of 1480 were to be suspended during periods of war.

<sup>3</sup> Clairac, *Du Negoce, de la Banque*, &c. (Bordeaux, 1656), pp. 112–117, a scarce and valuable volume.



tors, who shall be elected between the 25th of March and the 25th day of April each year, from among the members of the company duly qualified.

"That no dividend shall at any time be made by the said governor and company, save only out of the interest, profit, or produce arising by or out of the said capital, stock, or fund, or by such dealing as is allowed by Act of Parliament.

"They must be natural-born subjects of England, or naturalized subjects; they shall have in their own name, and for their own use, severally, viz., the governor at least £4000, the deputy-governor £3000, and each director £2000, of the capital stock of the said corporation.

"That thirteen or more of the said governors and directors (of which the governor or deputy-governor must be always one) shall constitute a court of directors, for the management of the affairs of the company, and for the appointment of all agents and servants which may be necessary, paying them such salaries as they may consider reasonable.

"Every elector must have, in his own name and for his own use, £500 or more capital stock, and can only give one vote. He must, if required by any member present, take the oath of stock, or the declaration of stock in case he may be one of the people called Quakers

"Four general courts shall be held in every year, in the months of September, December, April, and July. A general court may be summoned at any time, upon the requisition of nine proprietors duly qualified as electors. The majority of electors in general courts have the power to make and constitute bye-laws and ordinances for the government of the corporation, provided that such bye-laws and ordinances be not repugnant to the laws of the kingdom, and be confirmed and approved according to the statutes in such case made and provided."

The corporation is prohibited from engaging in any sort of commercial undertaking other than dealing in bills of exchange, and in gold and silver. It is authorised to advance money upon the security of goods or merchandise pledged to it, and to sell by public auction such goods as are not redeemed within a specified time.

It was also enacted, in the same year in which the bank was established, by statute 6 William and Mary, c. 20, that the bank "shall not deal in any goods, wares, or merchandise (except bullion), or purchase any lands or revenues belonging to the Crown, or advance or lend to their majesties, their heirs or successors, any sum or sums of money, by way of loan or anticipation on any part or parts, branch or branches, fund or funds of the revenue, now granted or belonging, or hereafter to be granted, to their majesties, their heirs and successors, other than such fund or funds, part or parts, branch or branches of the said revenue only on which a credit of loan is or shall be granted by Parliament." And in 1697 it was enacted, that the "common capital or principal stock, and also the real fund, of the governor and company, or any profit or produce to be made thereof, or arising thereby, shall be exempted from any rates, taxes, assessments, or impositions whatsoever during the continuance of the bank; that all the profit, benefit, and advantage from time to time arising out of the management of the said corporation, shall be applied to the uses of all the members of the said association of the governor and company of the Bank of England, rateably and in proportion to each member's part, share, and interest in the common capital and principal stock of the said governor and company hereby established."

In 1696, during the great recoinage, the bank was involved in great difficulties, and was even compelled to suspend payment of its notes, which were at a heavy discount. Owing, however, to the judicious conduct of the

directors, and the assistance of the Government, the bank got over the crisis. But it was at the same time judged expedient, in order to place it in a situation the better to withstand any adverse circumstances that might afterwards occur, to increase the capital from £1,200,000 to £2,201,171. In 1708 the directors undertook to pay off and cancel one million and a half of exchequer bills they had circulating two years before, at 4½ per cent., with the interest upon them, amounting in all to £1,775,028, which increased the permanent debt due by the public to the bank, including £400,000 then advanced in consideration of the renewal of the charter, to £3,375,028, for which they were allowed 6 per cent. The bank capital was then also doubled, or increased to £4,402,342. But the year 1708 is chiefly memorable in the history of the bank, for the Act previously alluded to, which declared, that during the continuance of the corporation of the Bank of England, "it should not be lawful for any body politic, erected or to be erected, other than the said governor and company of the Bank of England, or of any other persons whatsoever, united or to be united in covenants or partnership, exceeding the number of six persons, in that part of Great Britain called England, to borrow, owe, or take up any sum or sums of money on their bills or notes payable on demand, or in any less time than six months from the borrowing thereof." This proviso is said to have been elicited by the Mine Adventurers Company having commenced banking business and begun to issue notes. It will be seen on examination that the proviso did not prohibit the formation of associations for general banking business; it simply forbade the issue of notes by associations of more than six partners; but the issue of notes was regarded as so essential to the business of banking, that it came to be believed that joint-stock banking associations were absolutely prohibited in England, and no such association was founded until after the legislation of 1826 (see p. 322) expressly permitting them to be established. The charter of the Bank of England, when first granted, was to continue for eleven years certain, or till a year's notice after the 1st of August 1705. The charter was further prolonged in 1697. In 1708, the bank, having advanced £400,000 for the public service, without interest, the exclusive privileges of the corporation were prolonged till 1733. And in consequence of various advances made at different times, the exclusive privileges of the bank were continued by successive renewals till the 1st of August 1855, with the proviso that they might be cancelled on a year's notice to that effect being given after the said 1st of August 1855.

We subjoin an account of the successive renewals of the charter, of the conditions under which these renewals were made, and of the variations in the amount and interest of the permanent debt due by Government to the bank, exclusive of the dead weight.

Date of Renewal.	Conditions under which Renewals were made and Permanent Debt contracted.	Permanent Debt.
1694	<p>Charter granted under the Act 5 and 6 Will. III. c. 20, redeemable upon the expiration of twelve months' notice after the 1st August 1705, upon payment by the public to the bank of the demand therein specified.</p> <p>Under this Act the bank advanced to the public £1,200,000 in consideration of their receiving an annuity of £100,000 a year, viz., 8 per cent. interest and £4000 for management.</p>	<p>£    s.    d.</p> <p>1,200,000    0    0</p>
	Carry forward.....	1,200,000    0    0

Date of Renewal.	Conditions under which Renewals were made and Permanent Debt contracted.	Permanent Debt.			Date of Renewal.	Conditions under which Renewals were made and Permanent Debt contracted.	Permanent Debt.							
		£	s.	d.			£	s.	d.					
	Brought forward.....	1,200,000	0	0		Brought forward.....	11,686,000	0	0					
1697	<p>Charter continued by 8 and 9 Will. III. c. 20, till twelve months' notice after 1st of August 1710, on payment, &amp;c.</p> <p>Under this Act the bank took up and added to their stock £1,001,171 Exchequer bills and tallies.</p>				1764	<p>Charter continued by 4 Geo. III. c. 25, till twelve months' notice after the 1st of August 1766, on payment, &amp;c.</p> <p>Under this Act the bank paid into the Exchequer £110,000, free of all charge.</p>								
1708	<p>Charter continued by 7 Anne, c. 7, till twelve months' notice after 1st of August 1782, on payment, &amp;c.</p> <p>Under this Act the bank advanced £400,000 to Government without interest, and delivered up to be cancelled £1,775,027, 17s. 10d. Exchequer bills, in consideration of their receiving an annuity of £106,501, 13s., being at the rate of 6 per cent.....</p>	2,175,027	17	10	1781	<p>Charter continued by 21 Geo. III. c. 60, till twelve months' notice after the 1st of August 1812, on payment, &amp;c.</p> <p>Under this Act the bank advanced £20,000,000 for the public service for three years, at 3 per cent.</p>								
1718	<p>Charter continued by 13 Anne, stat. 1, c. 11, till twelve months' notice after the 1st of August 1743, on payment, &amp;c.</p> <p>In 1714, by the 3 Geo. I. c. 8, the bank advanced to Government, at 5 per cent.....</p> <p>And by the same Act the interest on the Exchequer bills cancelled in 1780 was reduced from 6 to 5 per cent.</p> <p>In 1721, by 8 Geo. I. c. 21, the South Sea Company were authorised to sell £300,000 Government annuities, and corporations purchasing the same at 26 years' purchase were authorised to add the amount to their capital stock. The bank purchased the whole of these annuities at 20 years' purchase.....</p> <p>Five per cent interest was payable on this sum to midsummer 1737, and thereafter 4 per cent.</p> <p>At different times between 1727 and 1738, both inclusive, the bank received from the public, on account of permanent debt, £2,275,027, 17s. 10d., and advanced to it, on account of ditto, £2,000,000: Difference.....</p> <p>Debt due by the public in 1738.....</p>	2,000,000	0	0	1800	<p>Charter continued by 40 Geo. III. c. 28, till twelve months' notice after the 1st of August 1838 on payment, &amp;c.</p> <p>Under this Act the bank advanced to Government £3,000,000 for six years without interest; but in pursuance of the recommendation of the committee of 1807, the advance was continued, without interest, till six months after the signature of a definitive treaty of peace.</p> <p>In 1816, the bank, under authority of the Act 56 Geo. III. c. 96, advanced at 3 per cent., to be repaid on or before the 1st of August 1838.....</p>	3,000,000	0	0					
		4,000,000	0	0	1838	<p>Charter continued by 3 and 4 Will. IV. c. 98, till twelve months' notice after the 1st of August 1855, with a proviso that it may be dissolved on twelve months' notice after the 1st of August 1855, on payment, &amp;c.</p> <p>This Act directs that in future the bank shall deduct £120,000 a year from their charge on account of the management of the public debt; and that a fourth part of the debt due by the public to the bank, or £2,671,000, be paid off.....</p> <p>Permanent advances by the bank to the public, bearing interest at 3 per cent., independent of the advances on account of dead weight, or other public securities held by it.....</p>	9,275,027	17	10		14,686,000	0	0	
		275,027	17	10			2,671,000	0	0					
		9,100,000	0	0	1844	<p>Charter continued by 7 and 8 Vict. c. 82, till twelve months after the 1st of August 1855, on payment, &amp;c.</p> <p>This Act exempts the notes of the bank from all charge on account of stamp-duty, and directs that in future the bank shall deduct a further sum of £180,000 a year from the charge on account of the management of the public debt. It also allows notes of the value of £14,000,000 to be issued on securities, separates the banking from the issuing department of the establishment, and effects other important changes.</p>				1861	<p>The Act 24 and 25 Vict. c. 3, provides fresh terms of payment to endure until the 5th April 1866. The amount to be deducted to be £60,000 plus the whole allowance out of profits of issue, making in all at that time £188,078, and now (1875) about £290,000.</p> <p>The amount to be issued on securities was raised to £15,000,000 on 21st February 1866.</p>			
1742	<p>Charter continued by 15 Geo. II. c. 13, till 12 months' notice after the 1st of August 1764, on payment, &amp;c.</p> <p>Under this Act the bank advanced £1,600,000 without interest, which, being added to the original advance of £1,200,000, and the £400,000 advanced in 1710, bearing interest at 6 per cent., reduced the interest on the whole to 3 per cent.....</p> <p>In 1745, under authority of 19 Geo. II. c. 6, the bank delivered up to be cancelled £986,000 of Exchequer bills, in consideration of an annuity of £89,472, being at the rate of 3 per cent.....</p> <p>In 1749, the 23d Geo. II. c. 6, reduced the interest on the 4 per cent. annuities, held by the bank, to 3½ per cent. for seven years from the 25th of December 1750, and thereafter to 3 per cent.</p> <p>Carry forward.....</p>	1,600,000	0	0			11,015,000	0	0					
		986,000	0	0										
		11,686,000	0	0										

The capital of the bank on which dividends are paid has never exactly coincided with, though it has seldom differed very materially from, the permanent advance by the bank to the public. We have already seen that it amounted in 1708 to £4,402,342. Between that year and 1727 it had increased to near £9,000,000. In 1746 it amounted to £10,780,000. From this period it underwent no change till 1782, when it was increased 8 per cent., amounting to £11,642,400. It continued stationary at this sum down to 1816, when it was raised to £14,553,000, by an addition of 25 per cent. from the profits of the bank, under the provisions of the Act 56 Geo. III. c. 96. The Act for the renewal of the charter 3 and 4 Will. IV. c. 98, directed that the sum of £3,671,700, being the fourth part of the debt due by the public to the bank, should be paid to the latter, giving the bank the option of deducting it from its capital. But that has not been done; and after sundry changes, the capital of the bank amounts, as formerly, to £14,553,000.

The Bank of England has been frequently affected by panics amongst the holders of her notes. In 1745 the alarm occasioned by the advance of the Highlanders, under the Pretender, as far as Derby, led to a run upon the bank; and in order to gain time to effect measures for averting the run, the directors adopted the device of paying in shillings and sixpences. But they derived a more effectual relief from the retreat of the Highlanders, and from a resolution agreed to at a meeting of the principal merchants and traders of the city, and very numerous signed, declaring the willingness of the subscribers to receive bank-notes in payment of any sum that might be due to them, and pledging themselves to use their utmost endeavours to make all their payments in the same medium.

During the tremendous riots in June 1780, the bank incurred considerable danger. Had the mob attacked the establishment at the commencement of the riots, the consequences might have proved fatal. But they delayed their attack till time had been afforded for providing a force sufficient to insure its safety. Since that period a considerable military force occupies the bank every night as a protection in any emergency that may occur.

*Progress of Banking in England down to Restriction Order of 1797.*

The business of banking had meanwhile been undertaken in several of the country towns of England. The still existing bank of Messrs Smith & Co. of Nottingham, the parent of the London establishment of Messrs Smith, Payne, and Smiths, claims to have been established in 1688; the Bristol Old Bank (Messrs Baillie, Cave, and Co.) dates from 1750; the Hull Old Bank (Messrs Pease and Co.) from 1754; and many other country banks trace back their history to the latter half of the last century. It is believed that all these bankers issued their own notes payable to bearer as part of their business; and they were not very scrupulous in regard to the magnitude of the sums for which they were given. The Bank of England had not issued any notes for less than £20 previously to 1759, when it commenced the issue of £10 notes; but the country bankers put in circulation notes for such small sums that Parliament enacted, in 1775, that none should be issued for less than £1. In 1777 this minimum limit was further raised to £5, but in spite of this restriction the number and the amount of the issues of the country bankers soon become dangerously multiplied. The termination of the American War was followed by a great industrial and commercial development at home. Agriculture, commerce, and still more, manufactures, into which Watt and Arkwright's inventions had been lately intro-

duced, immediately began to advance with a rapidity unknown at any former period. In consequence, that confidence which had either been destroyed, or very much weakened by the disastrous events of the war, was fully re-established. The extended transactions of the country required fresh facilities for carrying them on, and these were supplied in the utmost profusion. The number of banks, which in 1784 was certainly under 150, increased so rapidly, that in 1792 they amounted to about 350. In consequence, a banking office was opened in every market-town and in most considerable villages. And such being the case, it is needless, perhaps, to add, that the prudence, capital, and connections of those who set up these establishments were but little attended to. The great object of a large class of traders was to obtain discounts; and the bankers of an inferior description were equally anxious to accommodate them. All sorts of paper were thus forced into circulation, and enjoyed nearly the same degree of esteem. The bankers and those with whom they dealt had the fullest confidence in each other. No one seemed to suspect that there was anything hollow or unsound in the system. Credit of every kind was strained to the utmost; and the available funds at the disposal of the bankers were reduced far below the level which the magnitude of their transactions required to render them secure.

The catastrophe which followed was such as might easily have been foreseen. The currency having become redundant, the exchanges took an unfavourable turn in the early part of 1792. A difficulty of obtaining pecuniary accommodation in London was not long after experienced; and, notwithstanding the efforts of the Bank of England to mitigate the pressure, a violent revulsion took place in the latter part of 1792 and the beginning of 1793. The failure of one or two great houses excited a panic which proved fatal to many more. Out of the 350 country banks in England and Wales, when this revulsion began, about 300 were compelled to stop payments, and upwards of 50 were totally destroyed, producing by their fall an extent of misery and bankruptcy till then unknown in the country.

Attempts have sometimes been made to show that this crisis was not occasioned by an excess of paper money having been forced into circulation, but by the agitation caused by the war then on the eve of breaking out. But there does not seem to be any good grounds for this opinion. The symptoms of an overflow of paper—a fall of the exchange, and an efflux of bullion—took place early in 1792, or about twelve months before the breaking out of hostilities.

*Suspension of Cash Payments in 1797.*

The year 1797 is a most important epoch in the history of English banking. Owing partly to events connected with the war then carried on, to loans to the Emperor of Germany, to bills drawn on the treasury at home by the British agents abroad, and partly, and chiefly, perhaps, to the advances most unwillingly made by the bank to Government, which prevented the directors from having a sufficient control over their issues, the exchanges became unfavourable in 1795, and in that and the following year large sums of specie were drawn from the bank. In the end of 1796 and beginning of 1797, considerable apprehensions were entertained of invasion, and rumours were propagated of descents having been actually made on the coast. In consequence of the fears that were thus excited, runs were made on the provincial banks in different parts of the country; and some of them having failed, the panic became general and extended itself to London. Demands for cash poured in from all quarters upon the bank, which, on Saturday the 25th of February 1797, had only £1,272,000 of cash and bullion in its coffers, with

every prospect of a violent run taking place on the following Monday. In this emergency, an order in council was issued on Sunday the 26th, prohibiting the directors from paying their notes in cash until the sense of Parliament should be taken on the subject. And after Parliament met, and the measure had been much discussed, it was agreed to continue the restriction till six months after the signature of a definitive treaty of peace.

As soon as the order in council prohibiting payments in cash appeared, a meeting of the principal bankers, merchants, traders, &c., of the metropolis, was held at the Mansion-house, when a resolution was agreed to, and very numerously signed, pledging, as had been done in 1745, those present to accept, and to use every means in their power to make bank-notes be accepted, as cash in all transactions. This resolution tended to allay the apprehensions that the restriction had excited.

Parliament being in session at the time, a committee was immediately appointed to examine into the affairs of the bank; and their report put to rest whatever doubts might have been entertained with respect to the solvency of the establishment, by showing, that at the moment when the order in council appeared, the bank was possessed of property to the amount of £15,513,690, after all claims upon it had been deducted. This suspension of cash payments being naturally followed by a withdrawal of gold from circulation, made it necessary to allow of the issue of notes of a smaller denomination than £5, and the statute of 1777 was accordingly also suspended.

Much difference of opinion has existed with respect to the policy of the restriction in 1797; but, considering the peculiar circumstances under which it took place, its expediency seems abundantly obvious. The run did not originate in any over-issue of bank paper, but grew entirely out of political causes. So long as the alarms of invasion continued, it was clear that no bank paper immediately convertible into gold would remain in circulation. And as the bank, though possessed of ample funds, was without the means of instantly retiring its notes, it might, but for the interference of Government, have been obliged to stop payments,—an event which, had it occurred, might have produced consequences fatal to the public interests.

The error of the Government did not consist in their coming to the assistance of the bank, but in continuing the restriction after the alarm of invasion had ceased and there was nothing to hinder the bank from safely reverting to specie payments.

It had been generally supposed, previously to the passing of the Restriction Act, that bank-notes would not circulate unless they were immediately convertible into cash. But the event showed that this was not really the case. Though the notes of the Bank of England were not, at the passing of the Restriction Act, declared by law to be legal tender, they were rendered such in practice, by being received as cash in all payments on account of Government, and by the vast majority of individuals. For the first three years of the restriction, their issues were so moderate that they not only kept on a par with gold, but actually bore a small premium. But in 1801, 1802, and 1803, they were so much increased that they fell to a discount of from 8 to 10 per cent. In 1804 they again recovered their value; and from that year to 1808, both inclusive, they were at a discount of 2½ per cent. In 1809 and 1810, however, the directors appear to have embarked on a new course, and to have entirely lost sight of the principles by which their issues had previously been governed; for the average amount of bank-notes in circulation, which had not exceeded 17½ millions, nor fallen short of 16½ millions, in any one year, from 1802 to 1808, both inclusive, was in 1809 raised to £18,927,833, and 1810 to £22,541,523. The issues

of country bank paper were increased in a still greater proportion; and, as there was no corresponding increase of the business of the country, the discount on bank-notes rose from 2½ in 1808 to from 13 to 16 per cent. in 1809 and 1810.

This depreciation in the value of bank paper being accompanied by a corresponding fall in the exchange attracted the attention of the public and the legislature. In consequence, the House of Commons appointed, in 1810, a committee to inquire into the subject; and having examined several witnesses, the committee in their report, which was both an able and a celebrated paper, justly ascribed the fall in the value of bank paper, as compared with gold, to its over-issue; and recommended, in the view of correcting the existing evil and of preventing its recurrence, that within two years the bank should be obliged to resume specie payments. But this recommendation not being adopted, the over-issue of paper went on increasing. In 1812 it was at an average discount, as compared with bullion, of 20 per cent.; in 1813, of 23 per cent.; and in 1814, when the maximum of depreciation was attained, it was at 25 per cent.

At the period when the restriction on cash payments took place in 1797, it is supposed that there were about 280 country banks in existence; but so rapidly were these establishments multiplied, that they amounted to above 900 in 1813. The price of corn, influenced partly by the depreciation of the currency and the facility with which discounts were obtained, but more by deficient harvests and the unprecedented difficulties which the war threw in the way of importation, rose to an extraordinary height during the five years ending with 1813. But the harvest of that year being unusually productive, and the intercourse with the Continent being then also renewed, prices, influenced by both circumstances, sustained a very heavy fall in the latter part of 1813 and the beginning of 1814. And this fall having ruined a considerable number of farmers and produced a general want of confidence, such a destruction of provincial paper took place as has rarely been paralleled. In 1814, 1815, and 1816, no fewer than 240 country banks stopped payment; and *eighty-nine* commissions of bankruptcy were issued against these establishments, being at the rate of one commission against every *ten and a half* of the total number of banks existing in 1813.

The great reduction that was thus suddenly and violently brought about in the quantity of country bank paper, by extending the field for the circulation of Bank of England paper, raised its value in 1817 nearly to a par with gold. The return to cash payments being thus facilitated, it was fixed, in 1819, by the Act 59 Geo. III. c. 78, commonly called Sir Robert Peel's Act, that they should take place in 1823. But to prevent any future over-issue, and at the same time to render the resumption as little burdensome as possible, it was enacted, in pursuance of a plan suggested by Mr Ricardo, that the banks should be obliged, during the interval from the passing of the Act till the return to specie payments, to pay its notes, if required, in bars of standard bullion of not less than sixty ounces weight. This plan was not, however, acted upon during the period allowed by law; for, a large amount of gold having been accumulated at the bank, the directors preferred recommending specie payments on the 1st of May 1821.

The fluctuations, referred to above, in the value of paper were exceedingly injurious. From 1809 to 1816, the creditors of every antecedent contract, land-holders whose estates had been let on lease, stockholders and annuitants of every description—all, in short, who could not raise the nominal amount of their claims or incomes proportionally to the fall in the value of money, were to that extent losers. The injustice that would have been done to the creditors of the state and of individuals, who had made their loans

in gold, or paper equivalent to gold, by raising the denomination of the coin twenty-five per cent., however gross and palpable, would not have been greater than was actually done them in 1814, by compelling them to receive payment of their just debts in paper depreciated to that extent.

It is true, that after a currency has been for a considerable period depreciated, as much injustice is done by raising, as was previously done by depressing, its value. But there is good reason to doubt whether the depreciation from 1809 to 1815 (for the depreciation of  $2\frac{1}{2}$  per cent. during the six preceding years is too inconsiderable to be taken into account) extended over a sufficiently lengthened period to warrant the Legislature in departing from the old standard. It is needless, however, to offer any opinion on this rather difficult point, for we have seen that the value of paper was raised in 1816 and 1817 almost to par by accidental circumstances without any interference on the part of Government or of the bank. Sir Robert Peel's Act, to which this rise had been ascribed, not being passed till 1819, could have nothing to do with what occurred two or three years previously. Its object was twofold, to redeem the pledge given by Parliament to restore the old standard on the return of peace, and to shut the door against any fresh depreciation of paper.

*History of Banking from the Resumption of Cash Payments to the Crisis of 1825.*

The resumption of cash payments did not, however, put an end to the vicissitudes of banking. Notwithstanding the ample experience that had been supplied by the occurrences of 1792-93 and 1814-16, of the mischievous consequences of the issue of paper by the country banks, and of their want of solidity, nothing whatever was done, when provision was made for returning to specie payments, to restrain their issues, or to place them on a better footing. The consequences of such improvidence were not long in manifesting themselves. The prices of corn and other agricultural products, which had been greatly depressed in consequence of abundant harvests, in 1820, 1821, and 1822, rallied in 1823, and the country bankers immediately began to enlarge their issues. It is unnecessary to inquire into the circumstances which conspired, along with the rise of prices, to promote the extraordinary rage for speculation exhibited in 1824 and 1825. It is sufficient to observe, that in consequence of their operation, confidence was very soon carried to the greatest height. It did not seem to be supposed that any scheme could be hazardous, much less wild or extravagant. The infatuation was such, that even the most considerate persons did not scruple to embark in visionary and absurd projects; while the extreme facility with which discounts were procured upon bills at very long dates, afforded the means of carrying on every sort of undertaking. The most worthless paper was readily negotiated. Many of the country bankers seemed, indeed, to have no other object than to get themselves indebted to the public. And such was the vigour and success of their efforts to force their paper into circulation, that the amount of it afloat in 1825 is estimated to have been nearly 60 per cent. greater than in 1823. The consequences of this extravagant and unprincipled conduct are well known. The currency having become redundant, the exchanges began to decline in the summer of 1824. The directors of the Bank of England having unwarily entered, in the early part of that year, into an engagement with the Government to pay off such holders of 4 per cent. stock as might dissent from its conversion into a  $3\frac{1}{2}$  per cent. stock, were obliged to advance a considerable sum on this account after the depression of the exchange. But despite this circumstance, they might and ought to have

taken measures, in the latter part of 1824 and the earlier part of 1825, by lessening their issues to stop the efflux of bullion. But not being sufficiently alive to the urgency of the crisis, the London currency was not materially diminished till September 1825. The recoil, which would have been less severe had the efforts of the bank to prevent the exhaustion of its coffers taken place at an earlier period, was most appalling. The country banks began to give way the moment they experienced a considerably increased difficulty of obtaining accommodation in London, and confidence and credit were immediately at an end. Suspicion having awakened from her trance, distrust had no limits. All classes of depositors made haste to call up the sums they had entrusted to the care of the banks. There was also a run upon them for payment of their notes, not in the view of sending the gold as a mercantile adventure to the Continent, but to escape the loss which it became obvious the holders of country paper would have to sustain. *Sauve qui peut* was the universal cry; and the destruction was so sudden and extensive, that in less than six weeks above seventy banking establishments were swept off, and a vacuum was created in the currency which absorbed from eight to ten millions of additional issues by the Bank of England, at the same time that myriads of those private bills that had previously swelled the amount of the currency, and added to the machinery of speculation, were wholly destroyed.

It may be worth while, perhaps, to observe that it has been alleged, in opposition to what is now stated, that the difficulties of the bank in 1825 were not caused by any excess either of its issues or of those of the country banks, but by the too great amount of the capital, that is of coin and bullion, it had lent; and in proof of this allegation, we are referred to the increase of nearly eight millions in the amount of securities which the bank held in August 1825 over their amount in August 1822, and to the simultaneous decrease of nearly six and a half millions in the amount of bullion in its coffers.<sup>1</sup> But a little consideration will suffice to show the futility of this statement. No issue of notes can be said to be in itself excessive. Whether it is or is not in excess depends upon its relation to the amount of coin and bullion reserved by the issuing bank in its coffers. The Bank of England enlarged its issues disproportionately and took no steps, or none of sufficient energy, to reduce the amount of notes in circulation till long after the exchange had become unfavourable, and bullion was demanded of it for exportation. The accumulation of securities was the necessary result of this radical error. The currency having become redundant in 1824, the notes of the bank were returned upon it for gold, so that its securities were augmented at the same time that its means of dealing with the unfavourable exchange were impaired. It is to be remembered, that the efflux of bullion showed conclusively that, however issued, and whether greater or less than at former periods, the paper afloat was in excess, and that its reduction had become indispensable. And such being the case, it was the duty of the bank directors, as soon as they felt the drain for gold setting steadily against them, to adopt every means in their power, by raising the rate of interest, selling securities, and otherwise, to reduce their issues, and restore

Securities of all sorts, 31st August 1822, .....	£17,290,510
" " " " 31st August 1825, .....	25,106,080
Excess of Securities, 31st August 1825, over those held on 31st August 1822, .....	£7,815,570
Bullion in Bank, 31st August 1822, .....	£10,097,960
" " " " 31st August 1825, .....	3,634,320
Diminution of bullion, .....	£6,463,640

On the 28th February 1826, the bullion in the bank amounted to only £2,459,510.

the exchange to par. And had they done this at a sufficiently early period, it is all but certain the bank would not have lost more than two or three millions of bullion; whereas, by their following a different line of conduct, and deferring the adoption of vigorous repressive measures till too late a period, it was drained of about seven millions of bullion, and its safety seriously compromised before it could stop the drain.<sup>1</sup>

*Legislation of 1826—Suppression of £1 Notes—Joint-Stock Banks of Issue authorised.*

Notwithstanding the fact that nations are slow and reluctant learners, the events of 1825–26, taken in connection with those of the same sort that had previously occurred, produced a conviction of the necessity of doing something that should at least improve the system of country banking in England. But the measures adopted with this view were very far indeed from effectually securing their object. The law of 1708, limiting to six the number of partners in banking establishments issuing notes, was repealed; and it was enacted, that banks with any number of partners might be established for the issue of notes anywhere beyond sixty-five miles from London, and that banks not issuing notes might be established in London itself with any number of partners. The circulation of notes for less than five pounds in England and Wales was at the same time forbidden. It was intended to extend the same prohibition to Scotland and Ireland, but the opposition to the proposal excited in these countries was too strong to be overcome. Sir Walter Scott threw himself zealously into the controversy, and by his *Letters of Malachi Malagrouther*, helped to make the resistance effectual.

The suppression of £1 notes was advantageous in shutting up one of the principal channels by which the inferior class of country bankers got their paper into circulation, to the frequent loss of the poorer classes; but it is now generally admitted that the balance of argument is in favour of the issue of notes of this denomination by the Bank of England or some agency of the state, under conditions ensuring their convertibility.

The second branch of the banking legislation of 1826 was for some time a comparative failure. Those who supposed that joint-stock banks would be immediately set on foot in all parts of England, were a good deal disappointed with the slowness with which they spread for some years after the Act permitting their establishment was passed. The heavy losses occasioned by the downfall of most of the joint-stock projects set on foot in 1824 and 1825, made all projects of the same kind be looked upon for a considerable period with suspicion, and deterred most persons from embarking in them. But this caution gradually wore off; and the increasing prosperity of the country, and the difficulty of vesting money so as to obtain from it reasonable return, generated anew a disposition to adventure in hazardous projects. A mania for embarking in speculative schemes acquired considerable strength in 1834; and during 1835 and part of 1836, it raged with a violence but little inferior to that of 1825. It was at first principally directed to railroad projects; but it soon began to embrace all sorts of schemes, and, among others, joint-stock banks, of which an unprecedented number were projected in 1835. The progress of the system was as follows:—

Banks.	Banks.
In 1826 there were registered 6	In 1832 there were registered 10
In 1827..... 1	In 1833..... 13
In 1828..... 5	In 1834..... 8
In 1829..... 4	In 1835..... 45
In 1830..... 3	In 1836..... 11
In 1831..... 8	
	Total..... 114

In point of fact, however, the number of banks created in 1835 and 1836 was vastly greater than appears from this statement. It seems that, at an average, each of the 56 banks established in those years, like those previously established, had from four to five branches; and as these branches transacted all sorts of banking business, and enjoyed the same credit as the parent establishment, from which they were frequently at a great distance, they were, to all intents and purposes, so many new banks; so that, instead of 56, it may safely be affirmed that from about 220 to 280 new joint-stock banks were opened in England and Wales in 1835 and 1836, but mostly in the former year.

In January, February, and March 1836, when the rage for establishing joint-stock banks was at its height, the exchange was either at par, or slightly in our favour, showing that the currency was already up to its level, and that if any considerable additions were made to it, the exchange would be depressed, and a drain for bullion be experienced. But these circumstances, if ever they occurred to the managers of the joint-stock banks, do not seem to have had, and could not in truth be expected to have, any material influence over their proceedings. Their issues, which amounted on the 26th of December 1835 to £2,799,551, amounted on the 25th of June 1836 to £3,588,064, exclusive of the vast mass of additional bills, cheques, and other substitutes for money they had put into circulation. The consequences were such as every man of sense might have foreseen. In April 1836 the exchange became unfavourable, and bullion began to be demanded from the Bank of England. The directors, that they might the better meet the drain, raised the rate of interest in June from 4 to 4½ per cent, and this not being enough sufficiently to lessen the pressure on the bank for discounts, they raised it in August from 4½ to 5 per cent. But during the whole of this period the country banks went on increasing their issues; and the issues of the joint-stock banks rose from £3,588,064 in June, to no less than £4,268,197 on the 31st of December, being an increase of nearly 20 per cent. after the exchange was notoriously against the country; and the most serious consequences were apprehended from the continued drain for bullion.

It may, perhaps, be supposed that the increased issue of the joint-stock banks would be balanced by a corresponding diminution of the issues of the private banks, and that on the whole the amount of their joint issues might not be increased. This, however, was not the case. Some private banks were abandoned in 1836, and others incorporated with joint-stock banks; and it is further true, that those which went on managed their affairs with more discretion than their associated competitors. But, from the 26th of September 1835 to the 31st of December 1836, the issues of the private banks were diminished only £169,087, whilst those of the joint-stocks were increased during the same period £1,750,160, or more than *ten times* the falling off in the others.

These statements show the inexpediency of leaving the issue of paper to the unregulated discretion of an indefinite number of competing banks. Its issue ought in all cases to be governed by the state of the exchange, or rather, as already stated, by the influx and efflux of bullion. But previously to 1844, the provincial banks might go on over-issuing for a lengthened period without being affected by a demand for bullion, or even for Bank of England paper.

<sup>1</sup> It may be observed that Mr McCulloch (on whose contributions to the seventh and eighth editions of this work the present article is based) pointed out in a paper in the *Scottishman*, published in 1825, what would be the inevitable result of the bank allowing the drain of bullion to run its course, viz, that it would be drained of its last sovereign, and obliged to stop payments; and that it could not avert this result otherwise than by narrowing its issues, and raising the value of the currency. The directors did this at last, but they ought to have done it nearly twelve months sooner.

In the end, no doubt, an efflux of the former was sure, by rendering money and all sorts of pecuniary accommodation scarce in the metropolis, to affect the country banks as well as the Bank of England; and then the injury to industry, occasioned by the withdrawal of their accustomed accommodations from a great number of individuals, was severe in proportion to the too great liberality with which they had previously been supplied. This was especially the case in 1836, when the Bank of England, by bolstering up the Northern and Central Bank, averted, though but for a while, the bankruptcy of that establishment, which had no fewer than forty branches, and, by doing so, is said to have prevented the occurrence of a panic that might have proved fatal to many other joint-stock and private banks. Still, however, the shock given to industrial undertakings, by the revulsion in the latter part of the year, and in 1837, although unaccompanied by any panic, was very severe. All sorts of commercial speculations were for a while completely paralyzed, and there were but few districts in which great numbers of individuals were not thrown out of employment. In Paisley, Birmingham, and most other towns, the distress occasioned by the revulsion was very general and long-continued. And owing to the Bank of England having delayed, in 1838 and the earlier part of 1839, to take efficient measures for the reduction of its issues, despite the unmistakable evidence of their being redundant, the bullion in its coffers was reduced in September 1839 to £2,406,000; and, but for the efficient assistance obtained from the Bank of France, its stoppage could hardly have been averted.

*Act of 1844—Objections to and Defence of that Act—  
Suspensions of in 1847, 1857, and 1866.*

This perilous experience having again forcibly attracted the public attention to the state of the banking system, Sir Robert Peel was induced to attempt its improvement. The clause in the Act 3 and 4 Will. IV. c. 9, which renewed the bank charter in 1833, gave Parliament power to revise or cancel it in 1845, and thus afforded a legitimate opportunity for the introduction of the new system. It was indispensable, in attempting to obviate the defects inherent in our currency, to proceed cautiously, to respect, as far as possible, existing interests, and to avoid taking any step that might excite the fears or suspicions of the public; but the measures which Sir Robert Peel introduced and carried through Parliament in 1844 and 1845, for the improvement of the English banking system, were so skillfully contrived as to provoke little opposition, at the same time that they effected most important and highly beneficial changes.

The measures in question consisted of the Act 7 and 8 Vict. c. 32, which refers to the Bank of England and the English country banks; and the Acts 8 and 9 Vict. c. 38, 37, referring to the banks of Scotland and Ireland. These statutes were intended to obviate the chances of over-issue, by limiting the power to issue notes payable on demand, and by making the amount of such notes in circulation vary with the amount of bullion in the possession of the issuers, and this object has been perfectly attained. The statutes have as completely failed to attain a second object contemplated by their author—that of preventing great and rapid fluctuations in the rate of discount; and the truth is now recognized, that the power of over-issuing notes is one of many causes which may conduce to variations in the rate of discount and by no means the most efficient of them. In dealing with the Bank of England, Sir Robert Peel adopted the proposal previously made by Lord Overstone,<sup>1</sup>

<sup>1</sup> In tracts published in 1837 and 1840, and in his evidence before a committee of the House of Commons in the latter year.

for effecting a complete separation between the issuing and banking departments of that establishment, and giving the directors full liberty to manage the latter at discretion, while they should have no power whatever over the other.

The notes of the Bank of England in circulation for some years previously to 1844 rarely amounted to twenty, or sunk so low as sixteen millions. And such being the case, Sir Robert Peel was justified in assuming that the circulation of the bank could not, in any ordinary condition of society, or under any merely commercial vicissitudes, be reduced below fourteen millions. And the Act of 1844 allowed the bank to issue this amount upon securities, of which the £11,015,100 lent by the bank to the public was the most important item. Inasmuch, however, as the issues of the provincial banks were at the same time limited in their amount, and confined to certain existing banks, it was further provided, in the event of any of these banks ceasing to issue notes, that the Bank of England might be empowered, by order in council, to issue, upon securities, two-thirds, and no more, of the notes which such banks had been authorised to issue. Under this condition, the total secured issue of the bank has (1875) been increased from £14,000,000 to £15,000,000. *But for every other note which the issue department may at any time issue over and above the maximum amount (£15,000,000) issued on securities, an equal amount of coin or bullion must be paid into its coffers.* And hence, under this system, the notes of the Bank of England are rendered really and truly equivalent to gold, while their immediate conversion into that metal no longer depends, as it previously did, on the good faith, the skill, or the prudence of the directors. And these important results have been attained without imposing any burden of which any one has any right to complain. Our currency rests on the fundamental principle, that all debts above forty shillings shall be paid in gold. But individuals and associations, including the banking or commercial department of the bank, have the option, if they prefer it, to exchange gold for bank-notes, and to make use of the latter in their dealings with the public. Hence, if A or B goes to the issuers of paper, and gets 100 or 500 notes from them in exchange for an equivalent amount of gold, it is his own convenience he has exclusively in view. He was at full liberty to use gold, but he preferred exchanging it for notes because he could employ the latter more advantageously. This is the way in which paper is issued under the Act of 1844; and such being the case, it is contradictory to say that it is productive either of hardship or inconvenience.

It is alleged that the new system is injurious by shackling the bank in the use of its credit, and the answer is, that it does this in order to prevent the greater injury of over-issues of paper. The Act prevents the bank from issuing substitutes for money which do not represent money. It does not absorb or lock up a single sixpence worth of capital, nor does it interfere in any manner of way with its employment. The gold in the issue department of the bank was not purchased by the bank, and does not belong to it. The bank is its keeper, but not its owner. It belongs to the public, or to the holders of bank-notes, who deposited it in the bank in exchange for notes, with and under the express stipulation, that on paying the latter into the bank they should receive back their gold. Any interference with these deposits would be an interference with property held in pledge for others, that is, it would be an act precisely of the same kind with that which exposes private bailees to penal servitude.

But though the bank directors may not lay violent hands on the property of the public, the bank, it is obvious, has at this moment the same absolute command over its entire capital and credit, that it would have were the Act of 1844

non-existent. Apart from the practice of issuing transferable notes, the bank is free from all restraint, and is in precisely the same situation as other banking or mercantile establishments. Its directors may lend or not lend as they please, and may lay down such conditions as they please in regard to the interest and the terms of loans and discounts. In short, they may do whatever they like with their own; but farther they are not permitted to go. They may not substitute shadows for realities. They cannot, whether to assist others, or to relieve themselves from embarrassment, issue a single note except upon a deposit of bullion. But this rule does not operate on the bank only. It applies to all individuals and associations. And to relax it in any degree would be—disguise it as one may—to authorize an issue of fictitious or spurious paper, and consequently to vitiate the currency and to abuse credit in the way that is sure to be in the end the most disastrous.

This statement shows the groundless nature of the charge which is often made against the Act of 1844, that under its operation the bank runs the risk of being brought to a stop, though it may have some five, six, or even eight millions bullion in its coffers. For it is plain that two things are confounded in this charge, which are quite distinct, and have no necessary connection with each other, viz., the proceedings of the bank in the capacity of issuer of notes, and its proceedings in the capacity of a banking company. In the former capacity it is all but impossible that it should be brought to a stop; and if such a thing should happen, there would not then be an ounce of bullion in its coffers. It is not, however, impossible nor even very improbable, that the bank should be brought, in its mercantile capacity, into difficulties, while there may be a large amount of bullion in the issue department. But, though such should be the case, is that any reason why the bank directors should be permitted to draw on funds that do not belong to them, and over which they have no control? Supposing the bank was in difficulties, is it to be allowed to right itself by setting aside the principle of *meum* and *tuum*, and seizing on what belongs to others? The directors would be the first to repudiate such a doctrine, which must be rejected by all men who have any sense of honour or regard for character.

One of the most plausible objections to the Act of 1844 is that it "limits the currency," that it makes no provision for the increasing demands of the public; and confines us in 1876, when the exports will probably exceed 220 millions, to the same amount of money as in 1844, when the exports did not exceed 58½ millions. The simple truth, however, is that the Act allows money to be imported and exported, to be retained or sent elsewhere, just as it is wanted, and what it does limit is the uncontrolled issue of paper representatives of money, which experience proved were too often emitted without any reference to the reserves of money kept to maintain the convertibility of the paper issued. The £14,000,000 (now £15,000,000) issued on securities is the only thing that is limited in the Act; everything else varies with the varying condition and circumstances of the country, including the means by which the use of money may be economized. In the week ending the 7th July 1876, the issue department of the bank had issued notes to the amount of £41,029,955, being no fewer than £26,029,955 over and above the amount authorized to be issued on securities. And if the country had really required a larger supply of money, that is, if more coins, or paper equivalent to coins, could have been absorbed into the circulation without rendering the currency redundant, and depressing the exchange, the additional quantity would have been forthwith supplied. For, under such circumstances, merchants, bankers, and money-dealers, would have realized a certain and imme-

diated profit by carrying bullion to the mint or the bank, that they might obtain coins, or notes, or both, with which to increase the currency. It is one of the chief merits of the Act of 1844, that, under its agency, the supply of money is not to any extent or in any degree regulated or influenced by the proceedings of the bank or the Government. They have nothing to do in the matter, unless it be to coin the bullion which individuals or firms carry to the mint for that purpose, and to exchange, when called upon, notes for coins, and coins for notes. The supply of money, like that of all non-monopolized articles, is wholly dependant upon, and is determined by the free action of the public. It would, indeed, be quite as true to say, that the Act of 1844 limits the amount of corn, of cloth, or of iron produced in the country, as that it limits the amount of money. It maintains the value of the notes issued by the bank on a level with the coins for which they are substitutes; but beyond that its effect is nil. It has nothing whatever to do with the greater or less amount of the coin and notes of trustworthy convertibility put into circulation. That depends entirely on the estimate formed by the public of its excess or deficiency, an estimate which when wrong is sure to be corrected by the exchange.

We may add, that no inference can ever be safely drawn from the number of notes or coins, or both, afloat in a country, as to whether its currency be, or be not, in excess. That is to be learned by the state of the exchange, or by the influx and efflux of bullion. If the imports of bullion exceed the exports, it shows that the currency is in some degree deficient; while, if the exports exceed the imports, it shows that the currency is in excess, and that no additions can be made to it without farther depressing the exchange and increasing the drain of bullion. When the imports and exports of bullion are about equal, then of course the currency is at about its proper level. These are the only criteria by which anything can ever be correctly inferred in regard to the deficiency or excess of currency. Its absolute amount affords hardly even a basis for conjecture. When there is little speculation or excitement, an issue of 25 or 27 millions bank-notes may be in excess; while, at another time, and with a different state of trade and speculation, an issue of 35 or 37 millions of notes may not be enough. Except in periods of internal commotion, or when we are disturbed by alarms of invasion, the state of the exchange is the only, as it is the infallible, test of the sufficiency and insufficiency of the currency. We may further state, that those who are in the habit of complaining of the limitation of the currency by the Act of 1844, almost uniformly underrate its amount. We have already seen that, in the week ending the 7th July 1876 the notes issued by the issue department of the bank amounted to £41,029,955, and of these £12,453,415 were in the banking department of the bank, leaving a balance of £28,576,540 in the hands of the general public; and this latter sum is, we are told, the real amount of the issues. But this is falling into the rather serious blunder of mistaking a part for the whole. The notes in the banking department of the bank make not only a part, but a most important and active part, of the currency of the country. They constitute the means, along with the bullion in the same department, with which the bank carries on her banking business, and are as evidently a portion of the currency as the notes in the tills of private bankers and the pockets of individuals. The notes in the banking department of the bank must therefore never be omitted in estimating the amount of notes in circulation. The latter, and the notes out of the issue department, are identical; and, in a general point of view, it matters not a straw whether they are in the hands of the banking department of the bank or of individuals.



So far we have dealt with the legislation of 1844 in its bearing on the Bank of England. The desire of Sir Robert Peel reached beyond this, but he was unable to complete his policy. He rightly held that experience had shown that the balance of advantages lay on the side of the suppression of all note issues except that of the Bank of England, as reformed by him, or of some similar supplementary establishments regulated in the same manner. But it was obviously impossible to prohibit, without compensation, the future exercise by country bankers of the rights they had legitimately acquired; and as it was not easy to buy up the existing privileges of the private and joint-stock banks, Sir Robert Peel allowed them to remain under conditions prohibiting their extension, and he apparently hoped that country issues would gradually disappear before the rivalry of Bank of England notes. The Act of 1844, accordingly, enacted that no new bank for the issue of notes should be established in any part of the United Kingdom; and that the *maximum* issue of notes by the existing country banks of England should in future be limited to the average amount which they had respectively in circulation during the twelve weeks preceding the 27th April 1844. It was also ordered that the names of the partners in joint-stock and other banks should be periodically published. A provision was also enacted under which an issuing bank could resign its privilege by composition with the Bank of England. The existing law was maintained preventing the issue of any notes other than the Bank of England in London, and the establishment, within sixty-five miles of London of any branch of an English joint-stock bank having the privilege of issue.<sup>1</sup>

The convertibility of the Bank of England notes has been perfectly maintained since 1844, and the management of English banks, whether private or joint-stock, has been sound and judicious, the cases of failure among them being few and contrasting strongly with the recurrent epidemics of insolvency of earlier experience. It must, however, be admitted that the variations in the rate of discount charged by the bank have been much more numerous and violent since 1844 than they were before, and on three occasions—in 1847, 1857 1866—it has been judged necessary to authorize a suspension of the Act so far as to allow the bank directors the power to strengthen the banking department by recourse to the reserves of the issue department. In each case the suspension of the Act arrested and allayed the panic prevailing up to the moment of suspension, and in 1866 it was not, in fact, found necessary to exercise the power to borrow from the issue department which had been conceded to the directors. We must proceed to inquire whether the Act of 1844 is to be blamed for the increase in the number of changes of the rate of discount which has since been experienced, and whether this increase and the suspension of the Act in time of trial constitute a reason for its abrogation or for a modification of its provisions.

In the first place, the increased number of changes in the rate of discount is more apparent than real. The management of the Bank of England has become responsive to the movement in the value of money in the open market in a degree unknown before this generation. The rate of discount outside the bank changed rapidly and often before 1844, but its fluctuations were to a large extent prevented from affecting the Bank of England. Previously to the modification of the Usury Laws in 1839, the bank could not charge more for loans than 5 per cent., and for some considerable period after the restriction had been removed the directors, influenced, in part at least, by their accustomed habit on several occasions, permitted the bank to be involved

in difficulties which might have been averted by their sooner raising the rate of discount. Strict limitation in the number and class of customers with whom the bank would do business, and a refusal to rediscount bills that had been already discounted by money-dealers, made it possible to keep the bank rate below the rates of the open market without exposing the resources of the establishment to an exhausting demand.

Next, it is to be observed that the methods of economizing the use of money by the development of banking have been extraordinarily multiplied since 1844. The Bank Act, as we have shown, in no way operates to diminish the supply of money in the country; on the contrary, it tends to increase it, since it forbids any extension of the use of notes issued on credit as a substitute for money. The effect of the Act has therefore been to neutralize rather than to stimulate the process of economy in the use of money to which we have called attention. But the transactions of bankers—the issue of cheques, the negotiation of bills, &c. &c.—have multiplied out of all proportion to the stock of ready money on which they rest, and the mass of transitory credits being constantly increasing while the reserves of cash suffers little change, there naturally and necessarily follows an increased sensibility in the equilibrium of the money market, with constant oscillations in the rate of interest. But although the increase in the number of changes of discount since 1844 has not been as great as may at first seem apparent, and so far as the increase has been real it must be chiefly attributed to the growing disproportion between the magnitude of transitory credits at any time existing and the reserve of cash kept on hand, yet it may be freely admitted that it is not improbable that changes have from time to time happened that might not have occurred supposing the separation of the banking and issue departments had not been established. It is evident that if the cash in the two departments had been equally accessible to the bank directors, a withdrawal of money which is now thrown upon one department would not have caused so great a change in the proportion between liabilities and reserve as is now exhibited; and if the directors had reason to believe that the withdrawal was no more than a temporary efflux to the provinces or elsewhere, to be followed by a speedy reflux, they might have been bolder in abstaining from raising the rate of discount. But this action or rather inaction would have been indulged in at the price of a certain risk to the convertibility of the note, which is now avoided, and if it should appear in the end that the directors had erred in supposing the movement of money to be but temporary, they would see reason to regret that they had not been forced to stringent action at the beginning of it. The oscillations experienced in the rate of discount, oscillations which after all indicate nothing more than the natural movement in the value of a medium which is the first to be agitated by changes in value of every other commodity, are cheaply purchased as the price of the permanent and perfect equality of the bank-note and the money it represents. The repeated suspensions of the Act of 1844 in time of trial do, *prima facie*, present a much stronger argument for the repeal of the statute. Legislation which breaks down upon critical occasions discredits the Legislature that decreed it; and it is not to be denied that the mere suspension of the Act has more than once operated as a charm to allay feelings of panic among bankers, money-dealers, and merchants. It must also be admitted that Sir Robert Peel, in common with the earlier advocates of the policy of the Act, believed that it would prevent the recurrence of commercial crises. It is strange that such an anticipation should have been entertained. Whoever will reflect on the nature of the organization of credit in the commercial world, and on the timid and self-

<sup>1</sup> The provisions regulating the issues of Scotch and Irish banks will be found below, p. 332 *seq.*

protecting instincts of men, especially of capitalists, will be forced to confess that the recurrence of crises must be accepted as inevitable. The more highly developed is the economy of money the greater must be the sum which banks and bankers are liable to be called upon to repay on demand or at short notice in proportion to the reserves of money kept in their coffers; and the greater also must be the amount of bills falling due daily, and largely met as they fall due by the proceeds of bills drawn daily and discounted as drawn. The smoothness of action of the commercial machine evidently depends upon the continuance of that confidence which is ordinarily felt by the creditor-class in the solvency of debtors, and any access of distrust may easily produce consequences culminating in a crisis. Bankers who are at once debtors and creditors are necessarily constrained to protect themselves in such periods of defective confidence by declining to meet the applications for loans and discounts which are forced upon them; and a sharp competition ensues for the possession of the ready money that is available in the market. The pressure is concentrated upon the Bank of England, and the publicity of the condition of that institution, consequent upon the weekly issue of its balance-sheet, lets all men know the rate of decline of its cash reserve. At such a time an accident may cause the spirit of caution to pass into apprehension and panic. The fear that the cash balances of the banking department may be exhausted incites bankers to hasten to anticipate one another in withdrawing any reserve they may have kept at the bank, and the rate of diminution of the cash of the department is accelerated. It is obvious that the condition we have described is in its origin independent of any particular regulations adopted with respect to the note-circulation of a community; and it has, in fact, been experienced in Great Britain under all varieties of laws, and in the United States, in Northern and Southern Germany, and in the British colonies under an equally wide dissimilarity of currency-regulations. Our history previous to 1844 shows that such a condition may be aggravated, if not precipitated, by an antecedent issue of notes increasing the proportion between the volume of transitory credits and the cash available to meet instantaneous demands; and as long as the issue of notes was unrestricted, bankers could never resist the temptation to make up, by an increase in their issues, any diminution in their available cash, a cause directly provocative of a further diminution by its effect on adverse exchanges, and therefore producing a sharper reaction when the necessity was at last recognised of recovering the balance between their cash in hand and their liabilities. The Act of 1844 cannot prevent panic, but it prevents bankers from resorting to causes which aggravate panics, and it moreover supplies a means of allaying the unreasonable terror in which panics culminate. Were it not for the separation of the issue and the banking departments we should be constrained to witness and tolerate periodical suspension of cash payments, as this would be the only means left of appeasing alarm; and this desperate expedient has been, in fact, employed over and over again, under such circumstances, both in England and elsewhere. The Act of 1844 gives us a less dangerous, though by no means a perfectly harmless, power. When the minds of creditors are unhinged, and all are competing for money which is not in existence in sufficient quantities to satisfy their demands, the announcement that the Government has authorised the bank directors to suspend the action of the Act and to fall back on the resources of the issue department operates as a charm. The mere announcement is often enough to put an end to the panic previously prevailing, the feverish fit passes away, and the customary temper of confidence is more or less slowly restored.

We conclude that the existence of the Act of 1844 is justified even when it is suspended, for it provides, in the maintenance of the cash reserves of the issue department, a stock of money, the unlocking of which furnishes the means of arresting panic which would otherwise have to be sought in a periodic suspension of cash payments. It has naturally been asked whether the law might not be saved the apparent discredit involved in its being set aside by an act of the Executive Government, acting on the faith of a subsequent indemnity from Parliament, by the embodiment in it of a power authorizing its suspension under circumstances that provoke its suspension. Mr Lowe, as Chancellor of the Exchequer, introduced into the House of Commons, in 1873, a bill having this object. He proposed that the Bank Act might be suspended by order of the Government of the day when the minimum rate of discount had reached 12 per cent, when the exchanges were favourable to England, and when the governor and deputy-governor of the bank certified that panic had caused a large portion of the bank notes nominally in circulation to be locked up and withdrawn from circulation. The authority of Mr Gladstone's administration had declined when this bill was introduced, and it was not well received. It was contended that the conditions proposed by Mr Lowe had not always existed when the Act had been suspended, and they would be so rarely satisfied that the power of suspension promised by the bill could never be exercised. It was further contended that Mr Lowe's attempt was necessarily impracticable. In seeking to define beforehand the conditions of suspension of the Bank Act, he tried to define the conditions of a panic; and to attempt to define the conditions of that which is in its essence unreasonable was a logical contradiction. A panic has no laws: it has no fixed shape. It is precipitated we know not how; and we are in the midst of it before we are aware. As it is thus impossible to prescribe beforehand the conditions of panic, it may reasonably be thought that it is better to leave to the Government of the day the responsibility of acting when a panic has demonstrated its existence. Mr Lowe's bill, assailed from many quarters, was withdrawn without the opinion of Parliament being taken on its merits, and no attempt has been since made to bring the subject before the Legislature.

We have already said that Sir Robert Peel contemplated an ultimate extinction of all note issues save that of the Bank of England; and he probably expected that the substitution of Bank of England notes for all others would not be long delayed. The progress actually achieved towards this end has been very slow. Out of 204 private banks in England and Wales left by the Act of 1844, with total privileged issues of £5,153,407, no more than 85 have ceased to issue; and the amount they issued which is now withdrawn was £1,283,041. Of joint-stock banks 18 have ceased to issue £842,453, out of 72 having privileged issues of £3,495,446. Only one Scotch bank has ceased to issue notes since the Scotch Act of 1845, and no alteration whatever has taken place in the fixed issues of the Irish banks. It may be added that the provisions of the Act of 1844, relied upon by Sir Robert Peel for bringing about by arrangement a substitution of Bank of England notes for those of privileged bankers, have been for many years entirely neglected. With these facts before us it is not surprising that, in 1865, Mr Gladstone, as Chancellor of the Exchequer under Lord Palmerston, should have submitted to the House of Commons a bill dealing with the subject. By it, it was proposed that private banks of issue in England and Wales should be released from the existing restriction that the numbers of partners must not exceed six, and that joint-stock banks should be allowed to come within the circle of sixty-five miles from London upon their

undertaking to pay annually to the Exchequer a duty at the rate of 2 per cent. (altered in committee on the bill first to 1½ and then to 1 per cent.) on their average issues, and that thereupon their privileges of issue should be assured to them until 1890 (altered in committee to 1875 and 1880), after which these privileges should cease and determine. The bill was purely permissive; but it was thought by its author that a large proportion of the English banks of issue would place themselves under its operation, and further legislation would be practicable with respect to the rest. The bill, however, was less and less approved as it became better known, and it was ultimately withdrawn. From that time no legislation on the subject has been contemplated until the session 1875, when the action of the Scotch banks in establishing head offices in London was followed by an agitation, described in the section on Scotch banks (p. 332), which has resulted in the appointment of a select committee on the law of banking and of note issues.

The Select Committee thus appointed has received a vast mass of evidence on the law and practice of banking and of the issue of notes, but the session has been allowed to close without any attempt being made to report on the subject of the committee's inquiries, and no practical action is expected to follow the termination of its labours. It must be admitted that the obstacles to legislation, supposing legislation to be desirable, are considerable. The bankers of the kingdom are largely represented on both sides of the House of Commons, and they are on the whole well contented with the present state of the law, while the great body of the public are profoundly ignorant and uninterested in it. The inaction to be overcome is so great, and the force available is so limited, that nothing will be done except under the influence of a commercial crisis, when almost anything may be done. The aim of economists and statesmen should be to produce a body of authority that may command respect even in the midst of universal agitation; and the inquiries of the Select Committee to which we have referred might be useful for this purpose, if they had been pursued with any discrimination. As it is, the evidence received by the committee will probably serve as a quarry to which wisdom and unwisdom may equally resort for facts and arguments.

At the risk of stating something that may appear too obviously true to require statement, we would submit that the question, whether bankers should be permitted to issue notes, must be determined upon a balance of opposing considerations of expediency. Many of the advocates and supporters of Sir Robert Peel's legislation of 1844 have said, apparently with a conviction that they were expressing an axiomatic truth, that the issue of notes was no part of the business of a banker. Mr Gladstone has, within the past session, spoken in this sense. The force of assertions of this kind cannot be admitted. There is no law of nature limiting the action of a banker within the bounds sought to be prescribed; and if we accept as the definition of a banker a person whose business it is to borrow and lend money, we cannot but recognize in the issue of transferable notes a most convenient process of carrying on this business. A banker who issues notes borrows so much from the persons from time to time holding them, and this money he has lent to the customers indebted to him. The reasons of convenience which justify a prohibition of the liberty of issue are, first, that experience has shown that this process of borrowing is too potent and too easily abused to the precipitation and aggravation of commercial crises; and, secondly, that the great and almost insuperable difficulty of refusing to receive notes which have obtained general currency makes it most desirable that such notes should possess some

better guarantee than can be always forthcoming of the solvency of private issuers. These are the reasons which prevail to uphold Sir Robert Peel's legislation, and which impel us to consider what means may be discovered of perfecting his policy by the unification of issues throughout the kingdom.

We believe the propagation of clear ideas on the subject of the note currency, and the acceleration of the time when one currency only shall be in circulation, would both be greatly facilitated by a mechanical and local separation of the issue department from the Bank of England. Much confusion of thought still prevails by reason of the fact that the Bank of England is used as the agent for managing what is now a state issue, resting, so far as it is uncovered by specie, upon state security. If the business of issuing notes were removed bodily from the Bank of England and located in a Government office, and the name of the notes at the same time changed, it could not fail to be seen that the business left behind in Threadneedle Street differed in no essential particular from that of any other banker in Lombard Street, and much of the superstitious regard of the City for the Bank of England, and trust in its assistance in time of trouble, would be rapidly destroyed. It would then be understood that the cry for ministerial interference at the time of crises and of incipient crises was nothing more than a claim for the nation to cover with its credit those who had not been prudent enough to maintain adequate reserves for their own defence; and, as this would be understood beforehand, it would induce the consequence of greater circumspection on the part of dealers in money and a less temptation to rely on extraneous aid. The purely mechanical act of removing the issue of notes from Threadneedle Street would make the facts of the situation plain, and would bring about an alteration of conduct among London bankers, so that it should conform to the facts thus perceived. It has for some time past been clearly perceived that the delicacy of the condition of the money market in London has been much exaggerated, and the feverish tendency to crises materially excited, because the cash reserves kept by the London bankers are disproportionately small compared with the amount of their instantaneous liabilities. Competition has, of course, been a considerable element in causing this attenuation of cash reserves. Each joint stock bank has struggled after that increase of credit which follows an increase of dividends; and the unproductive cash balances on hand have been kept down to the lowest limit. They would, however, never have been reduced to such narrow dimensions but for the reliance placed on the assistance of the Bank of England in the last extremity; and if it were made plain that the Bank of England is itself nothing more than a big joint-stock bank, this reliance would disappear. Many schemes, equally ingenious and chimerical, have been recently put forth for compelling bankers to keep larger reserves of cash in proportion to their deposits. The true way to remove the danger always threatening us under the system that exists is to produce a conviction among bankers that they must not expect help elsewhere if they become distressed through a default in their own reserves of cash.

If the separation of the issue department from the rest of the Bank of England was completed by its transfer to a Government office under the management of State agents, the unification of the issues of the kingdom might be accomplished by legislation akin to that adopted by the United States in relation to the national banks. Each bank of issue might be required to withdraw its own notes and to receive and put out in exchange for them notes emanating from the State establishment, but bearing a statement on their face of the banks through which they were issued. Government securities should be deposited by

the issuing banks for the amounts thus put into circulation, which must not exceed the amount of their existing authorized issues; and the interest on these securities would be paid to the banks, less a fixed charge to defray the cost of preparing and issuing the notes delivered to them. The notes thus issued would be payable at the central State office, and would circulate throughout the kingdom; but as often as they were brought back to the central office they would be cleared again by the several issuing banks for reissue unless the latter desired to retire from the arrangement, in which case the issuing bank would redeem the notes it issued, which would be cancelled, and the securities deposited, or a corresponding part of them, would be handed back. It would not be improper to force this plan on the acceptance of the privileged banks of issue, although we believe it would be freely accepted, inasmuch as their notes would at once acquire currency throughout the kingdom without discrimination of locality in exchange for the deposit of security, and the gain they now realize from the issue of notes would be left undiminished. We must, however, repeat the expression of the conviction that neither this nor any other change of the present system can be regarded as practicable until the impulse of agitating circumstances has stirred up Parliament to face the question.

*Different Species of Banks—The Clearing-house—Authorization of Banks with Limited Liability.*

We have elsewhere hinted at the subdivision of the business of banking which has accompanied the development of commerce. A banker borrows and lends money, but the conditions under which money is borrowed or lent may be extremely various, and the different classes of bankers are distinguished from one another by differences in the rules which they observe in borrowing or lending. Bankers may borrow money on call, at deposit, on debentures, at interest, or without interest, and they may lend on open credits, by discounting bills, by advances on mortgage repayable in instalments or otherwise, &c., &c.

*Banks of Deposit.*—These banks receive money on deposit, that is to say, on conditions that a certain prescribed notice shall be given of the time of withdrawal. They allow interest, and they usually lend a large proportion of their money on securities which are not at any moment immediately capable of being realized.

*Land Mortgage Banks* may be classed with banks of deposit, but they are also accustomed to borrow on debentures repayable at the end of one, two, three, or a larger number of years, at rates of interest varying with the period of the debenture. These institutions were first started for the purpose of granting facilities to the mortgagors of land. The money received on debentures was lent out again to proprietors and purchasers of land, who repaid their debts by annual instalments. It was in this way that the legislation of Stein was facilitated in Germany; the peasant being able to obtain at once from the Land Mortgage Bank the capital necessary to redeem the feudal rights of his lord, a debt which he repaid by a series of annual payments often corresponding to what he had previously paid as rent, until he became an absolute unincumbered owner of the fields he cultivated.

*Credit Companies*, such as the *Crédit Foncier*, the *Crédit Mobilier*, &c., &c., are strictly analogous to land mortgage banks, except that they invest their funds in loans on the security of general industrial undertakings, to which business they have added the function of negotiators of direct loans between companies formed for the conduct of such undertakings and the capitalist public.

*Discount Banks and Discount Agencies* borrow money on

call or deposit, and lend it exclusively in the discount of bills and negotiable securities, which they often rediscount with capitalists desirous of investing their money in forms capable of being speedily realized.

*Trust Associations* borrow money on debentures and invest it in the loans of foreign states or similar securities,—the principle of such an association being that the original investor can be secured against the default of any one borrower by the receipt of a high average rate of interest and the general solvency of the rest.

*Savings-Banks* are institutions established for the receipt of the smaller savings of the poor. As at present existing they are divided into two classes, the Trustees' Savings-banks and the Post Office Savings-banks; but it seems probable that some rearrangement of their machinery will be made in the next session of Parliament. For further particulars see SAVINGS-BANKS.

Allusion has already been made (*ante*, p. 316) to the Clearing-house. This institution was established, just a century ago, as a place where the clerks of the bankers in the City of London could assemble daily to exchange with one another the cheques drawn upon and bills payable at their respective houses. Before the Clearing-house existed, each banker had to send a clerk to the places of business of all the other bankers in London to collect the sums payable by them in respect of cheques and bills; and it is obvious that much time was consumed by this process, which involved also the use of an unnecessary quantity of money and corresponding risks of safe carriage. In 1775 the common centre of exchange was agreed upon. Its use was confined to the bankers,—at that time and long afterwards exclusively private bankers,—doing business within the City, and the bankers in the west end of the metropolis used some one or other of the City banks as their agent in clearing, a practice which still continues. When the joint-stock banks were first established the jealousy of the existing banks was powerful enough to exclude them altogether from the use of the Clearing-house; and some years elapsed before this feeling was removed so as to allow them to be admitted.

At first the Clearing-house was simply a place of meeting, but it came to be perceived that the sorting and distribution of cheques, bills, &c., could be more expeditiously conducted by the appointment of two or three common clerks to whom each banker's clerk could give all the instruments of exchange he wished to collect, and from whom he could receive all those payable at his own house. The payment of the balance settled the transaction, and an analysis of the statistics of the Clearing-house by the late Mr Babbage (*Jour. Statist. Soc.*, March 1856), shows that the amount of cash that passed was often less than 4 per cent. of the total sums cleared. Latterly, however, the arrangements of the Clearing-house have been further perfected, so that neither notes nor coin are now required. The Clearing-house, as well as each banker using it, has an account at the Bank of England; and the balances due at the close of each day's transactions are settled by transfers from one account to another at the bank.

The use of the Clearing-house was still further extended in 1858, so as to include the settlement of exchanges between the country bankers of England. Before that time each country banker receiving cheques on other country bankers sent them to those other bankers by post (supposing they were not carrying on business in the same place), and requested that the amount should be paid by the London agent of the banker on whom the cheques were drawn to the London agent of the banker remitting them. Cheques were thus collected by correspondence, and each remittance involved a separate payment in London. In 1858 it was proposed to set up a country clearing-house in

London; but it was suggested by Sir John Lubbock that the existing establishment could accomplish what was desired, and this was eventually done. A country banker now sends cheques on other country banks to his London correspondent, who exchanges them at the Clearing-house with the correspondents of the bankers on whom they are drawn. (Sir John Lubbock, *Jour. Statist. Soc.*, Sept. 1865.) It will be easily understood that an extraordinary economy in the use of coin has resulted from these arrangements; and in the paper by Sir John Lubbock to which we have referred, he gives statistics showing that out of the sum of a million paid into the bank in which he is a partner, only £21,500 consists of bank notes and £6210 of coin. An ordinary weekly clearing varies from 100 to 130 millions; in 1868 the weekly average was, however, no more than £65,397,075, from which it rose continuously to an average of £116,254,717 in 1873. There was a little falling off in 1874, which is now being recovered.

Up to the year 1858 banking companies could not be constituted with limited liability of partners except by way of privilege under special Acts of Parliament, Royal Charters, or Letters Patent; and although the Bank of England, and the three oldest established banks in Scotland, were thus favoured without any consequent deterioration in the character of their management, abundant arguments were adduced in deprecation of a general law on the subject. In 1858, however, an Act was passed authorizing the formation and registration of banking companies with limited liability, and also enabling existing unlimited companies to register as associations with a limited liability of partners, subject to a proviso that, if the bank was a bank of issue, the liability of its partners should remain unlimited in respect of such issue. Several banks have been established and registered under this law, and no evil results have been observed to follow.

#### *Present Management of the Bank of England.*

When the charter was renewed in 1833, the notes of the Bank of England were made legal tender everywhere in England except at the bank. Of the wisdom of this regulation no doubt can be entertained. Bank-notes are necessarily always equivalent to bullion; and by making them substitutes for coin at country banks, the demand for the latter during periods of alarm or runs is materially diminished, and the stability of the bank and of the pecuniary system of the country proportionally increased.

Since 1826 the bank has established branches in some of the great commercial towns. The mode and terms of conducting business at these have been described as follows:—

“The branch bank at Swansea [and the same is true of those established in other places] is to be a secure place of deposit for persons having occasion to make use of a bank for that purpose; such persons are said to have *drawing accounts*: to facilitate to the mercantile and trading classes the obtaining of discounts of good and unexceptionable bills, founded upon real transactions, two approved names being required upon every bill or note discounted; these are called *discount accounts*. The applications of parties who desire to open discount accounts at the branch are forwarded to the parent establishment for approval, and an answer is generally received in about ten days. When approved, good bills may be discounted at the branch without reference to London. Bills payable at Swansea, London, or any other place where a branch is established, are discounted under this regulation. The dividends on any of the public funds, which are payable at the Bank of England, may be received at the branch by persons who have opened ‘drawing accounts,’ after signing powers of attorney for that purpose, which the branch will procure from London. No charge is made in this case, except the expense of the power of attorney and the postage incurred in transmitting it. Purchases and sales of every description of Government securities are effected by the branch at a charge corresponding to that made by the local bankers where the branch is situated. A commission, including brokerage in London, and all expenses of postage, is charged on paying at the Bank of England bills accepted

by persons having drawing accounts at Swansea, such bills to be advised by the branch; also for granting letters of credit on London, or on the other branches. The branch grants bills on London, payable at seven days’ date, without acceptance, for sums of £10 and upwards. Persons having drawing accounts at Swansea may order money to be paid at the bank in London to their credit at Swansea, and *vice versa*, at a charge of 6d. in lieu of postage. The branch may be called upon to change any notes issued and dated at Swansea; but they do not change the notes of the bank in London, nor receive them in payment, unless as a matter of courtesy where the parties are known. Bank post bills, which are accepted and due, are received at the branch from parties having drawing accounts, and taken to account without any charge for postage; but unaccepted bank post bills, which must be sent to London, are subject to the charge of postage, and taken to account when due. No interest is allowed on deposits. No advance is made by the branch upon any description of landed or other property, nor is any account allowed to be overdrawn. The notes are the same as those issued by the parent establishment, except being dated Swansea, and made payable there and in London. No note issued exceeds the sum of £500, and none are for a less amount than £5.”

The Bank of England transacts the whole business of Government. “She acts not only,” says Adam Smith, “as an ordinary bank, but as a great engine of state. She receives and pays the greater part of the annuities which are due to the creditors of the public; she circulates Exchequer bills; and she advances to the Government the annual amount of the land and malt taxes, which are frequently not paid till some years thereafter.”

The Bank of England rarely discounts bills that have more than two, or at most three months to run, and it were well were this rule generally observed by other establishments. The discounting of bills at long dates is a powerful stimulus to unsafe speculation. When individuals obtain loans which they are not to be called upon to pay for six, twelve, or, perhaps, eighteen months, they are tempted to adventure in speculations which are not expected to be wound up till some proportionally distant period; and as these not unfrequently fail, the consequence is that, when the bills become due, there is commonly little or no provision made for their payment. In such cases the discounters, to avert an imminent loss, sometimes consent to renew the bills. But, while a proceeding of this sort is rarely productive of ultimate advantage to either party, the fact of its having taken place makes other adventurers reckon that, in the event of their speculations proving to be less successful than they anticipated, their bills will be treated in the same manner, and thus aggravates and extends the evil.

In other respects, too, the discount of bills at long dates, or their renewal, or the making of permanent loans, is altogether inconsistent with sound banking principles, for it prevents the bankers from having that command over their resources which is advantageous at all times, and indispensable in periods of difficulty or distress.

In the discounting of bills, a great deal of stress is usually laid, or pretended to be laid, on the distinction between those that arise out of real transactions and those that are fictitious or that are intended for accommodation purposes. The former are said to be legitimate, while the latter are stigmatized as illegitimate. But Mr Thornton<sup>1</sup> has shown that the difference is neither so well marked nor so wide as many suppose. A notion seems to be generally entertained that all real bills are drawn against produce of one sort or other, which (or its value) is supposed to form a fund for their payment. Such, however, is not always, nor even most commonly, the case. A, for example, sells to B certain produce, for which he draws a bill at sixty days’ date. But prices are rising, trade is brisk, or a spirit of speculation is afloat, and, in a week or two (sometimes much less), B sells the produce at an advance to C, who thereafter sells it to D, and so on. Hence it may, and, in fact, frequently does happen, that bills amounting to

<sup>1</sup> On the Paper Credit of Great Britain, esp. 2.

four, five, or even ten times the value of a quantity of merchandise, have grown out of its successive sales, before the first bill of the series has become due. And not only this, but bills are themselves very frequently rediscounted; and in this case the credit of the last indorser is generally the only thing looked to; and there is not, perhaps, one case in ten in which any inquiries are made in regard to the origin and history of the bills, though they are often of the most questionable description.

On the whole, therefore, it would seem that the real or presumed solvency of the parties signing a bill, and responsible for its payment, is the only safe criterion by which to judge whether it should or should not be discounted. But the fact of a merchant or other trader offering accommodation bills for discount ought unquestionably to excite a suspicion that he is trading beyond his capital. Inquiries of the most searching description should forthwith be instituted; and unless satisfactory explanations are given, his paper should be rejected. On the same principle, the offering of bills for rediscount ought to awaken suspicions of the bankers and others who resort to so questionable a mode of carrying on business. But, except in so far as a feeling of distrust may be thus very properly excited, there does not appear to be anything in an accommodation bill *per se* to hinder it from coming within the pale of negotiability. It is a mode of obtaining a loan from a bank; and when the character of the bill is known to the banker, or is openly declared, it does not appear to be an objectionable mode.

Besides bills avowedly intended for accommodation purposes, another and a different variety of such bills is drawn by parties at a distance from each other, often men of straw, and made to appear as if they were bottomed on real transactions. Bills of this sort are, it is greatly to be regretted, always current, and often to a large extent. Of course no person of respectability can be knowingly connected with such bills, which are almost always put in motion either to bolster up some bankrupt concern, or to cheat and defraud the public. But despite the mischief of which they are productive, it appears to be pretty generally supposed that the currency of these bills is an evil which cannot be prevented. There can, however, be no real doubt that it may, at all events, be very greatly diminished; and this desirable result would be effected were it enacted that all bills shall henceforth bear upon their face what they really are; that those that are intended for accommodation purposes shall have at their head the words "*Accommodation bill*;" and that those only shall bear to be for "value received" that have grown out of *bona fide* transfers of property. An enactment of this sort could not be felt as a grievance by any one unless he had a fraudulent purpose in view. And were the impressing of a false character on a bill made a criminal offence, punishable by several years' imprisonment, there is every probability that a formidable check would be given to the issue of spurious bills, and to the manifold abuses to which the practice gives rise.

Bill-discounters who have got fictitious paper on their hands and attempt to get rid of it by concealing its character or representing it in a favourable light make themselves parties to the fraud. Such conduct is so very flagitious, that when it can be fairly brought home to the parties it should subject them to the severest penalties.

The rates of discount charged by the bank, since its establishment in 1694 down to 1845, were as follows:—

		Per cent.
From Aug. 8, 1694 to Aug. 30, 1694	on Foreign bills	6
Aug. 30, 1694	Jan. 16, 1695	Foreign bills 4½
Oct. 24, 1694	Jan. 16, 1695	Inland bills 6
Jan. 16, 1695	May 19, 1695	Foreign bills 6
Do.	to customers of the bank	8
Jan. 16, 1695	July 26, 1716	on Inland bills 4½

		Per cent.
From May 19, 1695 to Feb. 28, 1704	on Foreign bills	4
Do.	on Foreign bills not payable at the bank	5
Feb. 28, 1704 to June 22, 1710	on Foreign bills	5
June 22, 1710	July 26, 1716	For. & Inland do. 4
July 26, 1716	April 30, 1719	Bills and notes 5
April 30, 1719	Oct. 27, 1720	Bills 5
Oct. 27, 1720	Aug. 23, 1722	Bills 4
Aug. 23, 1722	Oct. 18, 1742	Inland bills 5
Do.	do.	Foreign bills 4
Oct. 18, 1742	Dec. 12, 1744	Foreign bills 5
Dec. 12, 1744	May 1, 1746	do. (15 d. to run) 4
Do.	do.	Inland bills 5
May 1, 1746	April 5, 1773	Foreign bills 5
May 1, 1746	June 20, 1822	Bills and notes 4
		95 days to run 4
June 20, 1822	Dec. 13, 1825	do. 5
Dec. 13, 1825	July 5, 1827	do. 5
July 5, 1827	July 21, 1836	do. 4
July 21, 1836	Sept. 1, 1836	do. 4½
Sept. 1, 1836	July 15, 1838	do. 5
Feb. 13, 1838	May 16, 1839	do. 4
May 16, 1839	June 20, 1839	do. 5
June 20, 1839	Aug. 1, 1839	do. 5½
Aug. 1, 1839	Jan. 23, 1840	do. 6
Jan. 23, 1840	Oct. 15, 1840	65-day bills 5
Oct. 15, 1840	June 8, 1841	95 day bills 5
June 8, 1841	April 7, 1842	do. 5
April 7, 1842	Sept. 5, 1844	do. 4
Sept. 5, 1844	Mar. 13, 1845	Bills 2½
Do.	do.	Notes 3

Since 1845 the changes of interest have been, for reasons already given, much more numerous. We give the number of changes in each year—

In 1845, 2 changes.	In 1855, 7 changes.	In 1865, 14 changes.
1846, 1 "	1856, 8 "	1866, 14 <sup>a</sup> "
1847, 10 <sup>b</sup> "	1857, 9 <sup>b</sup> "	1867, 3 "
1848, 3 "	1858, 6 "	1868, 2 "
1849, 1 "	1859, 5 "	1869, 7 "
1850, 1 "	1860, 9 "	1870, 9 "
1851, 0 "	1861, 13 <sup>c</sup> "	1871, 10 "
1852, 2 "	1862, 5 "	1872, 13 "
1853, 6 "	1863, 12 "	1873, 24 <sup>d</sup> "
1854, 3 "	1864, 14 <sup>e</sup> "	1874, 14 "

The dividends on bank stock, from the establishment of the company to the present time, have been as follows:—

Years.	Dividend.	Years.	Dividend.
1694, 8	per cent.	1823, 8	per cent.
1697, 9	"	1839, 7	"
1708, } Varied from 9 to		1852, 7½	"
1729, } 5½ per cent.		1853, 8	"
1730, 6	"	1856, 9½	"
1730, 5½	"	1859, 8½	"
1731, 6	"	1863, 8½	"
1738, 5½	"	1864, 9½	"
1747, 5	"	1865, 11½	"
1753, 4½	"	1866, 10½	"
1764, 5	"	1867, 10	"
1767, 5½	"	1868, 8	"
1781, 6	"	1869, 8½	"
1788, 7	"	1872, 9½	"
1807, 10	"	1873, 10	"

The Bank of England does not allow, either at the head

<sup>1</sup> Rising from 4 per cent. on 3d April to 8 per cent. on 20th Nov., declining again to 5 per cent. by 24th Dec., and to 3 in 1848.

<sup>2</sup> With the exception of one week the rate was high, varying from 4 to 5½ from Sept. 1853 to May 1856, from which date it rose to an average of 6 per cent. until Oct. 1857, when it rapidly mounted to 10 per cent. in Dec. 1857, and thence declined to 4 in Feb. 1858.

<sup>3</sup> 7 was the average rate in the spring, and 6 the average in the summer of 1861.

<sup>4</sup> At the end of 1863 the rate rose to 7 and 8 per cent., and it oscillated about these figures throughout 1864, twice falling to 6, and twice rising to 9 per cent.

<sup>5</sup> The average rate in 1865 was 4, but at the close of the year it rose to 6 and 7; and in 1866 it mounted until it reached 10 per cent. on the 15th August, from which it fell to 3½ before the end of the year.

<sup>6</sup> The crisis in America (see Banking in the United States, p. 341) was followed by a rapid rise from 3 per cent. on the 20th August to 9 per cent. on the 5th Nov., from which the rate receded to 4½ before the end of the year.

office in London, or at its branches, any interest on deposits, and many plausible reasons have been advanced in defence of this rule. They are well stated in the following extract from the evidence of Mr Weguelin, formerly governor of the bank, before the Committee of 1857:—

"We," said he, "at the Bank of England, have always considered that the proper functions of a banker were to keep the spare cash of his customer, such cash as his customer required for his daily expenditure, for the sudden demands of his business, and any accidental accumulation which might happen before the customer had occasion to invest it. That is contrasted with the system pursued by the joint-stock banks. The joint-stock bank invites a large deposit by offering a certain rate of interest for the deposit; in point of fact, the joint-stock bank becomes the investor of the money instead of the customer. The customer of a joint-stock bank does not himself invest his own money, but he employs the joint-stock bank to do it, taking the guarantee of the joint-stock bank, and taking, possibly, a lower rate of interest. Now, that system, if applied to the Bank of England, would be, I think, very prejudicial to the public interests. It would, in the first place, force upon the Bank of England to invest its reserves much more closely than it does now. If it had to pay interest upon its deposits, it could only do so by investing them in some securities that would pay a higher rate of interest than that which it pays. Its deposits also are of that particular character which would render it still more inexpedient that they should be closely invested. They consist, in the first place, of Government deposits, which rise from a low rate at one period of a quarter up to five or six millions higher at another period of a quarter, and again collapse to a very low rate at another period. Again, the private deposits consist, to a certain extent, of the deposits of the bankers and the joint-stock banks of London. Those deposits are the amounts which those bankers require to work their own business. Consequently, they are not deposits which should be very closely invested by the Bank of England. In times when there is a great accumulation of deposits in the Bank of England, it is because the public are not able at those times to find investments to their mind to employ those deposits; and consequently, it is not at all likely that the Bank of England, if that is the case with the public generally, will be able to find investments which the public themselves have not been able to do. All these reasons combined would lead me to think, that to force a system upon the Bank of England by which it should be obliged to employ its deposits very closely—much more closely than it does at present—would be not only prejudicial and unsafe as regards the Bank of England, but would be prejudicial to the public interest."—*Quæst.* 159.

It is, however, obvious that this reasoning is quite inconclusive. Mr Weguelin shows clearly enough that the directors of the bank would be bound to exercise great caution in the choice and extent of their investments, but he says nothing to explain why they should not, as the managers of a joint-stock company, use every means of profitably extending their business, and it is incontestable that if the bank directors offered to receive deposits at interest, the reputation of the bank would enable them to defy the competition of the other joint-stock banks. The truth is, that the non-allowance of interest is a tradition, of no authority in itself, and operating injuriously in keeping up the delusion that the banking department of the Bank of England is an institution differing essentially in the character of its business from other banks.

Previously to 1786 the bank received an allowance for paying the dividends, superintending the transfer of the stock, &c., of the national debt, at the rate of £562, 10s. a million on its amount. In 1786 this allowance was reduced to £450 a million, the bank being, at the same time, entitled to a considerable allowance for its trouble in receiving contributions on loans, lotteries, &c. This, though long regarded as a very improvident arrangement on the part of the public, was acquiesced in till 1808, when the allowance on account of management was reduced to £340 per million on £600,000,000 of the public debt, and to £300 per million on all that it exceeded that sum, exclusive of some separate allowances for annuities, &c. The impression, however, was still entertained that the allowances for management should be further reduced, and this has been effected in the interim.

Exclusive of its functions as public banker and manager

of the public debt, the Bank of England is connected with Government through the circulation. We have seen that it is entitled to issue the sum of £15,000,000 upon securities, that is, on the credit of the funds lent to Government. But for these the bank receives about 3 per cent. interest, and such being the case, the public is clearly entitled to a portion, if not to the whole amount of the profits realised by the bank on the issue of these £15,000,000. It is difficult to say how much this ought to be. The issue department of the bank seldom re-issues notes, but for the most part destroys them as soon as they are returned to it. This practice is said to be necessary to enable the bank to obviate fraud, by keeping a proper account of the numbers of the notes afloat. An opinion is, however, pretty generally entertained that this might be effected by a less expensive process than that which is now resorted to. And certainly, it seems to be a very wasteful proceeding, that a quantity of newly manufactured notes issued by the bank in the forenoon, and returned to her in the afternoon, should not be re-issued, but consigned to the flames. The Scotch banks are justly censurable for keeping their notes too long afloat, but this is running with a vengeance into the opposite extreme.

In 1861 a fresh arrangement was made between the Government and the bank, to endure for 25 years. Under this agreement the bank receives £300 per million on £600,000,000, and £150 per million on the amount of debt above that sum; but from these allowances are deducted £60,000 for exemption from stamp duties and the whole allowance out of profit of issue, making together nearly £300,000.

It should be observed that the responsibility and expense incurred by the bank, in managing the public debt, are very great. The temptation to the commission of fraud, in transferring stock from one individual to another, and in the payment of the dividends, is well known; and notwithstanding the skilfully devised system of checks adopted by the bank for preventing this, it has frequently sustained very great losses by forgery and otherwise. In 1803 the bank lost, through a fraud committed by one of the principal cashiers, Mr Astlett, no less than £340,000; and the forgeries of Fauntleroy, the banker, cost it a still larger sum. At an average of the ten years ending with 1831, the bank lost, through forgeries on the public funds, £40,204 a year.—(*Report on Bank Charter, Appen. p. 165.*)

Besides the transactions alluded to, the bank entered, on the 20th of March 1823, into an engagement with Government with respect to the public pensions and annuities, or, as they have been more commonly termed, the *dead weight*. At the end of the war, the naval and military pensions, superannuated allowances, &c., amounted to above £5,000,000 a year. They would, of course, have been gradually lessened, and ultimately extinguished, by the death of the parties; but it was resolved in 1822 to attempt to spread the burden equally over the whole period of *forty-five* years, during which it was calculated the annuities would continue to decrease. To effect this purpose, it was supposed that, upon Government offering to pay £2,800,000 a year for forty-five years, capitalists would be found who would undertake to pay the entire annuities, according to a graduated scale previously determined upon, making the first year a payment of £4,900,000, and gradually decreasing the payments until the forty-fifth and last year, when they were to amount to only £300,000. This supposition was not, however, realized. No capitalists were found willing to enter into such distant engagements. But in 1823, the bank agreed, on condition of receiving an annuity of £585,740 for *forty-four* years, commencing on the 5th of April 1823, to pay, on account of the pensions, &c., at different specified periods, between the years 1823

and 1828, both inclusive, the sum of £13,089,419.— (4 Geo. IV. c. 22.) This annuity has, in due course of time, expired.

Formerly the business transacted at the bank was so much encumbered with forms and conditions, that the generality of merchants and ordinary people rarely thought of employing it to keep their money or make their payments. But in this respect an entire change has been effected. Cheques, the minimum amount of which was formerly £10, may now be drawn of any amount, great or small; and all sorts of banking business is conducted with facility and despatch, and, it may be added, with perfect security.

The bank opens banking accounts, or, as they are called, "drawing accounts," for the safe custody, and the receipt and payment of cash, not only with merchants and traders, but with all persons who choose to keep their money at a banker's and to draw cheques against it. The bank also takes charge of its customers' bills of exchange, Exchequer bills, and other securities, and does all that is needful either in the collection of bills of exchange, the exchange of Exchequer bills, the receipt of dividends, and so forth, free of any charge. Plate chests, and deed and security boxes, may be deposited free of expense, by customers, for safe custody. The bank looks to the average balance of cash on each account to compensate for the trouble and expense of keeping it and in this respect the requirements of the bank are certainly not greater than those of ordinary bankers. No particular sum is required to be lodged on opening an account; it is only necessary that the party should be known as respectable, and in a condition to require a banking account. But the bank receives and holds sums of money for safe custody for parties who have no current accounts.

The following are the regulations under which accounts are conducted:—

1. All letters should be addressed to the chief cashier.
2. It is desirable that drafts should be drawn upon cheques furnished by the bank.
3. Cheques upon city bankers, eastward of King Street, Cheap-side,—  
Paid in by 12 o'clock may be drawn for after 1.  
Do. 2 o'clock after 3.
4. Cheques paid in after 2, and before 3 o'clock, and cheques upon all other London bankers paid in before 12 o'clock, may be drawn for on the following morning.
5. Cheques paid in after 3 o'clock are sent out at 9 the following morning, and may be drawn for as soon as received.
6. Dividend warrants are received at the drawing office until 4 o'clock in the afternoon for all persons having accounts at the bank.
7. It is requested that notice be given at the drawing office of bills accepted payable at the bank, with the date of their maturity.
8. Persons keeping a drawing account with the bank (although not having a discount account) may tender bills for discount through the drawing office. Application for discounts or for advances on stock, Exchequer bills, &c., must be made before 2 o'clock.
9. Bills of exchange and notes not paid when due, will be noted.
10. The bank will make purchases or sales of British or foreign securities upon an order in writing addressed to the chief cashier; and dividends on stock may be received under powers of attorney granted to the cashiers of the bank.
11. Exchequer bills, bonds, railway debentures, or any other securities may be deposited, and the interest, when payable, will be received and placed to account.
12. Credits paid in to account are received without the bank-book, and are afterwards entered therein without the party claiming them.
13. Notes of country bankers, payable in London, are sent out the same day for payment if paid in before 3 o'clock.
14. The pass-books should be left at the drawing office, at least once a month, to be written up.
15. Where post-bills are required, or a payment is to be made to any office of the bank by cheque on the Bank of England, the cheque must be presented at the office upon which it is drawn, and exchanged for an order on the post-bill office, or on the office at which the payment is to be made.

16. Cash-boxes taken in, contents unknown, for such parties as keep accounts at the bank.

17. A person having a drawing account may have a discount account; but no person can have the latter without at the same time having the former. When a discount account is opened, the signatures of the parties are entered in a book kept for that purpose, and powers of attorney are granted empowering the persons named in them to act for their principals. Bills of exchange having more than 95 days to run are not eligible for discount.

*N.B.*—All changes in the residence of persons keeping cash at the bank are requested to be made known at the drawing office; and it is particularly requested that no gratuities be offered to the clerks of the banking offices, such gratuities being strictly forbidden.

#### Scotch Banks.

The Act of 1708, preventing more than six individuals from entering into a partnership for carrying on the business of banking, did not extend to Scotland. In consequence of this exemption, several banking companies, with numerous bodies of partners, have existed, for a lengthened period, in that part of the empire.

The Bank of Scotland was projected by Mr John Holland, merchant, of London, and was established by Act of the Scotch Parliament (Will III., Parl. 1, § 5) in 1695, by the name of the Governor and Company of the Bank of Scotland. Its original capital was £1,200,000 Scotch, or £100,000 sterling, distributed in shares of £1000 Scotch, or £83, 6s. 8d. sterling, each. The Act exempted the capital of the bank from all public burdens, and gave it the exclusive privilege of banking in Scotland for twenty-one years. The objects for which the bank was instituted, and its mode of management, were intended to be, and have been, in most respects, similar to those of the Bank of England. The responsibility of the shareholders is limited to the amount of their shares. The capital of the bank was increased to £200,000 in 1774, and was enlarged by subsequent Acts of Parliament, the last of which (44 Geo. III. c. 23) was passed in 1804, to £1,500,000, its present amount.<sup>1</sup> Of this sum £1,000,000 has been paid up. The last-mentioned Act directed that all sums relating to the affairs of the bank should henceforth be rated in sterling money; that the former mode of dividing bank stock by shares should be discontinued; and that, for the future, it should be transferable in sums or parcels of any amount. On the union of the two kingdoms in 1707, the Bank of Scotland undertook the recoinage, and effected the exchange of the currency in Scotland. It was also the organ of Government in the issue of the new silver coinage in 1817.

The Bank of Scotland is the only Scotch bank constituted by Act of Parliament. It began to establish branches in 1696, and issued notes for one pound as early as 1704. The bank also began, at a very early period, to receive deposits on interest, and to grant credit on cash accounts, a minute of the directors with respect to the mode of keeping the latter being dated as far back as 1729. It is, therefore, entitled to the credit of having introduced and set on foot the distinctive principles of the Scotch banking system, which, whatever may be its defects, is perhaps superior to most other systems hitherto established. Generally speaking, the Bank of Scotland has been cautiously and skilfully conducted; and there can be no doubt that it has been productive, both directly and as an example to other banking establishments, of much public utility and advantage.

It may be worth mentioning, that the Act of Will. III. establishing the Bank of Scotland, declared that all foreigners who became partners in the bank should by doing so become, to all intents and purposes, naturalized Scotchmen. After being for a long time forgotten, this

<sup>1</sup> Although the capital of the Bank of Scotland remains, as stated in the text, as yet unused, was conferred on the bank by a private Act passed in 1873 to raise its capital to £3,000,000.



chance was taken advantage of in 1818, when several aliens acquired property in the bank in order to secure the benefit of naturalization. But after being suspended, the privilege was finally cancelled in 1822.

We subjoin an official abstract of the constitution and objects of the Bank of Scotland, printed in 1857 for the use of the proprietors;—the terms and model of transacting business are, of course, sometimes altered, according to circumstances:—

1. The Bank of Scotland is a public national establishment, erected and regulated by the Legislature alone, and expressly as a public bank in this kingdom,—for the benefit of the nation, and for the advancement of agriculture, commerce, and manufactures, and for other objects of public policy.—(Will. Parl. 1, § 5; 14 Geo. III. c. 32; 24 Geo. III. c. 8; 32 Geo. III. c. 25; 34 Geo. III. c. 19; 44 Geo. III. c. 23.)

2. The statutory capital is at present £1,500,000 sterling. It is raised by voluntary subscription, and has been subscribed for. £1,000,000 has been called for, and paid in.—(44 Geo. III. c. 23.)

3. Subscribers, if not under obligations to the bank, may, at pleasure, transfer their right. If under obligation to the bank, the obligation must be previously liquidated; or the proceeds of the sale, at a price to the satisfaction of the directors, must be applied towards such liquidation. Transfers are made by a short assignment and acceptance thereof, both in a register appointed for that purpose. The expense, besides the Government stamp, is 11s.—(Will. Parl. 1, § 5.)

4. Bank of Scotland stock may be acquired, in any portions, by any person, community, or other lawful party whatsoever, without selection, exclusion, or limitation of numbers.—(Will. Parl. 1, § 5; 44 Geo. III. c. 23.)

5. Bank of Scotland stock may be conveyed by will, and, if specially mentioned, without expense of confirmation. It cannot be arrested; the holder's right may be adjudged. Dividends may be arrested.—(Will. Parl. 1, § 5.)

6. The Bank of Scotland is a public corporation by Act of Parliament. The bank's transactions are distinct from those of the stockholders; and theirs from those of the bank.—(Will. Parl. 1, § 5.)

7. The establishment is expressly debarred from any other business than that of banking.—(Will. Parl. 1, § 5.)

8. The management is vested, by statute, in a governor, deputy governor, twelve ordinary, and twelve extraordinary directors. They are chosen annually, on the last Tuesday of March, by the stockholders having £250 of stock or upwards. Those above £250 have a vote for every £250, to £5000, or 20 votes. No person can have more than 20 votes. The governor must hold, at least, £5000 of stock; the deputy-governor £1500; and each director £750 (now £1000). They swear to be equal to all persons, and cannot hold any inferior office in the bank.—(Will. Parl. 1, § 5; 14 Geo. III. c. 32; 44 Geo. III. c. 23.)

9. The executive part is conducted by a treasurer, secretary, and other public officers, all sworn. All the officers of the Bank of Scotland find due security.—(Will. Parl. 1, § 5.)

10. The board of directors sits, for the general administration of the bank, at the bank's public head office in Edinburgh. The local business of that district is also conducted at that office. For the local business in the other parts of the kingdom, the bank has its regular public offices in the principal towns. At each of these offices there is the bank agent or cashier, who gives due security, and conducts the bank's business for that district in the manner aforementioned.—(Will. Parl. 1, § 5.)

11. The bank takes in money at all its public offices, on deposit receipts or on current deposit accounts. At the head office drafts on the branches, and at the branches drafts on the other branches and on the head office, are granted. Both at the head office and branches drafts are granted on the London, Dublin, and English and Irish provincial correspondents of the bank. All receipts and drafts are on the bank's engraved forms, and bear to be granted "For the Bank of Scotland," or "for the Governor and Company of the Bank of Scotland." At the head office official documents are signed by the treasurer, and at the branches by the agents, and all are countersigned.

Remittances can be made to the principal colonial and continental towns; and bills, payable in the colonies, and in foreign countries, can be negotiated through the bank.—(Resolution of Court, 1793, as since modified.)

N.B.—The bank has always allowed interest on deposits, at a rate varying according to circumstances.

12. Bills on London, Edinburgh, or any town in the United Kingdom, are discounted at all the bank's public offices. The bank's agents judge, in ordinary cases, of the bills presented, so that parties meet with no delay. The bank does not re-issue the bills

which it has discounted.—(Resolution of Court, 23d Feb. 1789, and subsequent modifications.)

13. Government stock and other public funds may be purchased or sold, and dividends thereon may be received through the bank.

14. The bank gives credit on cash accounts at any of its offices, on bond, with security. The security may be personal co-obligants, or such other security as may be specially agreed on. Applications for cash accounts are given in to the office where the cash account is wanted, and must specify the credit desired, and the security proposed; and the individual partners, where co-partneries are proposed. Cash accounts are granted by the directors only, and are not recalled unless by their special authority. It is understood that these credits are not used as dead loans, to produce interest only. In the fair course of business, the advantage of the bank is consulted by an active circulation of its notes, and by frequent repayments to it in a way least affecting that circulation.—(Resolution of Court, 9th Nov. 1729, and 23d Feb. 1789.)

15. The bank's dividend has been for some time 8 [It has risen till it is now (1875) 14] per cent. per annum on its paid-up capital of £1,000,000 sterling. The dividends are paid regularly twice a year, without expense. They may be drawn either at the bank's head office, or at any of its other offices, as most agreeable to the stockholder.<sup>1</sup>

The above may suffice as a general outline of the mode in which the business of banking is conducted in Scotland.

The Royal Bank of Scotland was established in 1727. Its original capital of £151,000 has been increased to £2,000,000.

The British Linen Company was incorporated in 1746, for the purpose, as its name implies, of undertaking the manufacture of linen. But the views in which it originated were speedily abandoned, and it became a banking company only. Its capital amounts to £1,000,000.

None of the other banking companies established in Scotland are chartered associations with limited responsibility, the partners being liable, to the whole extent of their fortunes, for the debts of the firms. The number of partners is in every case considerable. The affairs of the banks are uniformly conducted by a board of directors, annually chosen by the shareholders.

The Bank of Scotland began, as already stated, to issue £1 notes so early as 1704, and their issue has since been continued without interruption. "In Scotland," to use the statement given in the Report of the Committee of the House of Commons of 1826 on the Promissory Notes of Scotland and Ireland, "the issue of promissory notes payable to the bearer on demand, for a sum of not less than 20s., has been at all times permitted by law; nor has any Act been passed limiting the period for which such issue shall continue legal in that country."

All the Scotch banks receive deposits of as low a value as £10, and often lower, and allow interest upon them.

The interest allowed by the banks upon deposits varies, from time to time, according to the variations in the current rate of interest. The aggregate amount of the sums deposited with the Scotch banks in 1874-5 is stated to be £78,401,070.

A witness, connected for many years with different banks in Scotland, and who had experience of their concerns at Stirling, Edinburgh, Perth, Aberdeen, and Glasgow, being examined by the Commons' Committee of 1826, stated that more than half the deposits in the banks with which he had been connected were in sums from £10 to £200. Being asked what class of the community it is that makes the small deposits, he gave the following answer,—from which it appears that the mode of conducting this branch of the bank business in Scotland has long given to that country most part of the benefits derivable from the establishment of savings-banks:—

<sup>1</sup> Now that fundholders may have their dividend warrants sent them by post on notifying a desire to that effect, it is strange that stockholders in the Scottish banks should be still compelled to make personal application at an office of the bank for their dividends.

"Question.—What class of the community is it that makes the smallest deposits?

"Answer.—They are generally the labouring classes in towns like Glasgow; in country places like Perth and Aberdeen, it is from servants and fishermen, and that class of the community who save small sums from their earnings, till they come to be a bank deposit. There is now a facility for their placing money in the Provident Banks, which receive money till the deposit amounts to £10. When it comes to £10 it is equal to the minimum of a bank deposit. The system of banking in Scotland is an extension of the Provident Bank system. Half-yearly or yearly those depositors come to the

bank, and add the savings of their labour, with the interest that has accrued upon the deposits from the previous half-year or year, to the principal; and in this way it goes on, without being at all reduced, accumulating (at compound interest) till the depositor is able either to buy or build a house, when it comes to be £100, or £200, or £300, or till he is able to commence business as a master in the line in which he has hitherto been a servant. A great part of the depositors of the bank are of that description, and a great part of the most thriving of our farmers and manufacturers have arisen from such beginnings."

The following Table exhibits an account of the different Scotch Banks, their Partners, Branches, Authorized Circulation Actual Circulation, Coin, &c., in 1874-5 (from Oliver & Boyd's Almanac and Banks of Issue Report).

Instituted.	Name.	Partners.	Br.	Paid up Capital.	Res. or Reserve Fund.	Dividend per cent.	Amount of Deposits.	Price per £100 Stock (per share of those marked*)		
								1872.	1873.	1874.
				£	£		£	£	£	
1695	Bank of Scotland.....	1409	86	1,000,000	385,000	13½	10,632,000	287	292	303
1727	Royal Bank .....	1454	105	2,000,000	500,000	9½	10,063,000	192½	196	230½
1746	British Linen Co.....	1209	70	1,000,000	350,000	18†	7,703,000	283	272	291
1810	Commercial Bank.....	1223	101	1,000,000	407,114	16†	9,503,000	296	300	319
1825	National Bank of Scotland.....	1660	91	1,000,000	400,000	16†	10,874,000	307	300	319
1830	Union Bank of Scotland.....	1260	116	1,000,000	380,000	15	9,608,000	281	285	292
1825	Aberdeen Town and County Bank*	848	41	252,000	115,000	12½†	1,829,000	15½	15½	17½
1836	North of Scotland Bank*	1423	43	320,000	85,000	11½	2,465,000	9½	9½	11
1898	Clydesdale Bank.....	1383	79	1,000,000	500,000	16½	8,519,000	255	263½	284
1839	City of Glasgow Bank.....	1373	125	1,000,000	423,000	11	8,162,000	208	219	240
1838	Caledonian Bank*	804	21	125,000	62,581	14†	1,043,000	7½	7½	8½

\* The capital of banks marked with an asterisk is in shares.—The Aberdeen Town and County Bank, £7 paid; North of Scotland Bank, £4 paid; Caledonian Bank, £3, 10s. paid.

† Dividend, and bonus.

The loans or advances made by the Scotch banks are either in the shape of discounts, or upon cash-credits, or, as they are more commonly termed, *cash accounts*.

A cash-credit is a credit given to an individual by a banking company for a limited sum, seldom under £100 or £200, upon his own security, and that of two or three individuals approved by the bank, who become sureties for its payment. The individual who has obtained such a credit is enabled to draw the whole sum, or any part of it, when he pleases, replacing it, or portions of it, according as he finds it convenient, interest being charged upon such part only as he draws out. "If a man borrows £5000 from a private hand, besides that it is not always to be found when required, he pays interest for it whether he be using it or not. His bank credit costs him nothing, except during the moment it is of service to him, and this circumstance is of equal advantage as if he had borrowed money at a much lower rate of interest" (Hume's *Essay on Balance of Trade*). This, then, is plainly one of the most commodious forms in which advances can be made. Cash-credits are not, however, intended to be *dead loans*; and they are not granted except to persons in business, or to those who are frequently drawing out and paying in money.

The system of cash-credits has been very well described in the Report of the Lords' Committee of 1826 on Scotch and Irish Banking. "There is also," say their lordships, "one part of their system which is stated by all the witnesses (and, in the opinion of the Committee, very justly stated) to have had the best effects upon the people of Scotland, and particularly upon the middling and poorer classes of society, in producing and encouraging habits of frugality and industry. The practice referred to is that of cash-credits. Any person who applies to a bank for a cash-credit is called upon to produce two or more competent sureties, who are jointly bound; and after a full inquiry into the character of the applicant, the nature of his business, and the sufficiency of his securities, he is allowed to open a credit, and to draw upon the bank for the whole of its amount, or for such part as his daily transactions may require. To the credit of the account he

pays in such sums as he may not have occasion to use, and interest is charged or credited upon the daily balance, as the case may be. From the facility which these cash-credits give to all the small transactions of the country, and from the opportunities which they afford to persons who begin business with little or no capital but their character to employ profitably the minutest products of their industry, it cannot be doubted that the most important advantages are derived to the whole community. The advantage to the banks that give these cash-credits arises from the call which they continually produce for the issue of their paper,<sup>1</sup> and from the opportunity which they afford for the profitable employment of part of their deposits. The banks are indeed so sensible that, in order to make this part of their business advantageous and secure, it is necessary that their cash-credits should (as they express it) be frequently operated upon, that they refuse to continue them unless this implied condition be fulfilled. The total amount of their cash-credits is stated by one witness to be £5,000,000, of which the average amount advanced by the banks may be one-third.

The expense of a bond for a cash-credit of £500 is 12s. 6d. stamp duty, and a charge of from 5s. to 10s. 6d. per cent. for preparing it.

There have been, on the whole, comparatively few failures among the Scotch banks. In 1793 and 1825, when so many of the English banks were swept off, there was not a single establishment in Scotland that gave way. This superior solidity appears to have been owing to various causes,—partly to the banks having, for the most part, large bodies of partners, who, being conjointly and individually bound for the debts of the companies to which they belong, go far to render their ultimate security all but unquestionable, and partly to the facility afforded by the law of Scotland of attaching a debtor's property, whether it consist of land or movables, and making it available for the payment of his debts. This last-mentioned circumstance was referred to as follows, in the Report already alluded to:—

<sup>1</sup> The advantage of an increased issue is, however, much reduced, when the authorized issues are exceeded, and cash reserves are kept in hand equal to the excess.

"A creditor in Scotland is empowered to attach the real and heritable as well as the personal estate of his debtor, for payment of personal debts, among which may be classed debts due by bills and promissory notes; and recourse may be had, for the purpose of procuring payment, to each description of property at the same time. Execution is not confined to the real property of a debtor merely during his life, but proceeds with equal effect upon that property after his decease.

"The law relating to the establishment of records gives ready means of procuring information with respect to the real and heritable estate of which any person in Scotland may be possessed. No purchase of an estate in that country is secure until the *sasine* (that is, the instrument certifying that actual delivery has been given) is put on record, nor is any mortgage effectual until the deed is in like manner recorded.

"In the case of conflicting pecuniary claims upon real property, the preference is not regulated by the date of the transaction, but by the *date of its record*. These records are accessible to all persons; and thus the public can with ease ascertain the effective means which a banking company possesses of discharging its obligations; and the partners in that company are enabled to determine, with tolerable accuracy, the degree of risk and responsibility to which the private property of each is exposed."

But, on the whole, we are inclined to think that the long familiarity of the inhabitants with banks and paper money, and the less risk that has attended the business of banking in Scotland, have been the principal causes of the greater stability of the Scotch banks. This stability was not, however, everywhere exhibited in the crisis of 1857, when two of the principal Scotch banks, the headquarters of which were in Glasgow, were compelled to stop payments. They had very large capitals, the Western Bank £1,500,000, and the City of Glasgow Bank £1,000,000, with a great many branches, large amounts of deposits, and very numerous and wealthy proprietary bodies. Had the management of the Western Bank displayed anything like ordinary skill and prudence, it might have gone triumphantly through a far more serious trial. But having advanced immense sums to a few firms that never were entitled to any considerable credit, it was so crippled that, for a lengthened period before its stoppage, it was reduced to the expedient of sending up the bills it had discounted in Glasgow to be rediscounted in London; and when this resource failed it, and the other banks declined to come forward to its assistance, nothing remained for it but to shut its doors.<sup>1</sup> On the affairs of the bank being investigated by a committee appointed for the purpose, it was found that they were in a much worse state than any one could have anticipated. The losses exceeded two millions, and were directly attributable to the carelessness and negligence of directors, and the incompetence of the managers appointed by them.

We have already explained the nature of Sir Robert Peel's Act of 1845 (following that of 1844) dealing with Scotch banks. It allowed the Scotch banks then exercising the privilege of issuing notes to continue to exercise it, without limitation of amount, but subject to the condition, that for every note issued by a bank above its average circulation the year preceding the 1st May 1845 an equal amount in coin should be kept in its coffers. No bank established after the passing of the Act was allowed to issue notes. No change was effected by the Act in the denomination of notes issued which remained, therefore, of £1 and upwards. Many theorists have urged that £1 notes should be forbidden in Scotland, just as others have argued in favour of their being again put into circulation in England. This question cannot be settled upon abstract arguments. We have no doubt that the balance of reasoning is in favour of the issue of £1 notes, provided they are issued under regulations securing their convertibility at all times and

<sup>1</sup> The management of the City of Glasgow Bank was, as compared with that of the Western Bank, prudent and skilful. It recommenced and continues business.

under all circumstances, but these regulations are wanting in Scotland. Legislation on the subject should not take the form of suppressing £1 notes entirely, but of withdrawing the privilege of issuing them from the existing banks, and vesting it in a public institution governed by fixed rules analogous to those of the issue department of the Bank of England. When the convertibility of notes is thus made certain, the single valid objection against the issue of those of £1 denomination disappears. It may be added that more than one-half the total issues of the banks established in the Australian colonies consists of £1 notes.

A complaint has been often raised that the Act of 1845 gave the existing Scotch banks a practical monopoly of the business of banking in North Britain, and it must be admitted to be the fact, that only one new bank has been established in Scotland since the passing of the Act, and that bank carried on business for a short time only. It is, however, true that legislation precisely the same has not prevented the establishment of new banks in Ireland, and it is doubtful whether the observed fact is rightly attributed to the cause assigned to it. With the exception of London, and some of the larger provincial towns, there have been very few banks established in England since 1836, eight years before the Bank Charter Act; and of the banks established in 1836 and 1836, very many were formed by the conversion of pre-existing private banks into joint-stock associations. The truth appears to be that the natural obstacles to the establishment of a new bank in a district already occupied by banks and bankers are almost insuperable. A bank cannot be successful unless it commands credit; and those who want a place of safe keeping for their money select establishments that have been tried and tested through long years. Hence it happens that, though private banks of long standing continue in esteem, the attempts to set up new private banks are most rare; and, unless the wealth and prosperity of a neighbourhood have rapidly developed, so that capitalists have risen to prominence in it who are not connected as shareholders or directors with existing banks, it is not easy to form joint-stock associations of weight enough to compete with the institutions in possession of the field. It is not necessary to refer the absence of new banking companies in Scotland or elsewhere to the legislation of Sir Robert Peel. Though he allowed the Scotch banks to increase indefinitely the issue of their notes, it was upon condition of keeping in hand cash to represent every note above fixed limits; so that the amount of profit derivable from their issues is not capable of increase, and the value of their privileges will have been strictly included in the selling price of shares in these banks since 1845. As far as the privilege of issue goes, capitalists preparing to start a new banking association in Scotland would be in the same position as in buying shares in an established company; and if they do not start an association of their own, it is from the difficulty of attracting confidence, rather than because they would not enjoy the profits of a privileged circulation for which they would have to pay a full value. It must also be observed that the competition among the existing banks is sufficiently active to have caused them to increase the number of their branches 40 per cent. since 1845.

Another question has been raised in relation to Scotch banks, which was the subject of a keen parliamentary discussion during the past session (1875). It has been mentioned (*ante*, p. 322) that English joint-stock banks of issue are debarred from setting up branches in London, or within sixty-five miles of it, a prohibition originally imposed on them in the interest of the Bank of England as a bank of issue. There is no such prohibition affecting Scotch and Irish banks, which can set up offices in London or elsewhere in England subject to the single condition affecting all banking

establishments set up in England since 1844, that notes other than Bank of England notes are not issued at such offices; and it is obvious that a Scotch or Irish banking company establishing a head office in London would be able to give it at once a large agency business, and would be able to feed it continuously with new connections owing to the flow of immigration from Scotland and Ireland to London. Accordingly, the directors of the National Bank of Ireland began to conduct the general business of banking at their head office in London in 1854, and they have subsequently set up seven or eight branches in the metropolis, each of which is understood to be the centre of much business. This example was so far followed, that the National Bank of Scotland started an office in London in 1864; the Bank of Scotland did the same in 1867; and the Royal Bank in 1874, having obtained a private Act for the purpose. The Clydesdale Bank also opened three branches in Cumberland in 1874. In consequence of this action Mr Goschen brought into Parliament a bill, the object of which was to disable Scotch banks from coming into England, as English joint-stock banks of issue are disabled from coming to London. The bill did not extend to Irish banks, as they were held too firmly settled in the metropolis to be expelled from it. Two arguments were advanced in favour of this measure: the first, that it was hard that Scotch banks should be permitted to do that which is denied to English joint-stock banks; but it is an easy, and, as it would seem, a conclusive answer to this argument, that English joint-stock banks of issue should be freed from the disability now imposed upon them. Now that an increase in its issue is not a measure of profit to the Bank of England, there is no reason why these country banks of England should not be allowed to set up head offices in London, subject to the law forbidding the issue of their notes in London. The second argument in favour of Mr Goschen's measure was, that something ought to be done to hasten that unification of issues which Sir Robert Peel contemplated; and if the Scotch banks had come to Parliament asking for a liberty they did not possess, there would have been some plausibility in this argument. It is to be feared that the whole strength of the support to Mr Goschen's bill sprang from the jealousy of the existing bankers of London of any intrusion into their domain. Unworthy as this source of opposition was, it prevailed so far as to cause the appointment of a Select Committee of the House of Commons to consider the law and practice of banking, and this Committee's report has just appeared as these sheets are passing through the press (August 1875).

#### *Banking in Ireland.*

"In no country, perhaps," says Sir Henry Parnell, "has the issuing of paper money been carried to such an injurious excess as in Ireland. A national bank was established in 1783, with similar privileges to those of the Bank of England in respect to the restriction of more than six partners in a bank, and the injury that Ireland has sustained from the repeated failure of banks may be mainly attributed to this defective regulation. Had the trade of banking been left as free in Ireland as in Scotland, the want of paper money that would have arisen with the progress of trade would in all probability have been supplied by joint-stock companies, supported with large capitals and governed by wise and effectual rules.

"In 1797, when the Bank of England suspended its payments, the same privilege was extended to Ireland; and after this period the issues of the Bank of Ireland were rapidly increased. In 1797 the amount of the notes of the Bank of Ireland in circulation was £621,917; in 1810, £2,266,471; and in 1814, £2,986,999.

"These increased issues led to corresponding increased issues by the private banks, of which the number was fifty in 1804. The consequence of this increase of paper was its great depreciation; the price of bullion and guineas arose to 10 per cent. above the mint price; and the exchange with London became as high as 18 per cent., the par being 8½. This unfavourable exchange was afterwards corrected, not by any reduction in the issues of the Bank of Ireland, but by the depreciation of the British currency in the year 1810, when the exchange between London and Dublin settled again at about par.

"The loss that Ireland has sustained by the failure of banks may be described in a few words. It appears, by the Report of the Committee on Irish Exchanges in 1804, that there were, at that time, in Ireland fifty registered banks. Since that year a great many more have been established, but the whole have failed, one after the other, involving the country from time to time in immense distress, with the following exceptions—First, a few that withdrew from business; secondly, four banks in Dublin; thirdly, three at Belfast; and, lastly, one at Mallow. These eight banks, with the new Provincial Bank and the Bank of Ireland, are the only banks now (1827) existing in Ireland.

"In 1821, in consequence of eleven banks having failed nearly at the same time, in the preceding year, in the south of Ireland, Government succeeded in making an arrangement with the Bank of Ireland, by which joint-stock companies were allowed to be established at a distance of fifty miles (Irish) from Dublin, and the bank was permitted to increase its capital from 2½ to 3 millions sterling. The Act 1 and 2 Geo. IV. c. 72, was founded on this agreement. But ministers having omitted to repeal in this Act various restrictions on the trade of banking that had been imposed by 33 Geo. II. c. 14, no new company was formed. In 1824 a party of merchants of Belfast, wishing to establish a joint-stock company, petitioned Parliament for the repeal of this Act of Geo. II.; and an Act was accordingly passed in that session, repealing some of its most objectionable restrictions (5 Geo. IV. c. 73).

"In consequence of this Act, the Northern Bank of Belfast was converted into a joint-stock company, with a (nominal) capital of £500,000, and commenced business on the 1st of January 1825. But the restrictions of 33 Geo. II., and certain provisions contained in the Acts 1 and 2 Geo. III., and 5 Geo. IV., obstructed its progress, and they found it necessary to apply to Government to remove them; and a bill was accordingly introduced, which would have repealed all the obnoxious clauses of the 33 Geo. II., had it not been so altered in the committee as to leave several of them in force. In 1825 the Provincial Bank of Ireland commenced business with a (nominal) capital of £2,000,000; and the Bank of Ireland has of late established branches in all the principal towns."<sup>1</sup>

Since Sir Henry Parnell published the pamphlet from which we have taken the foregoing extract, several joint-stock banking companies have been founded in Ireland. The Provincial Bank, to which Sir Henry alludes, has a paid up capital of £540,000, and has been well and profitably managed. But others have been less fortunate. The Agricultural and Commercial Bank of Ireland, established in 1834, with 2170 partners, a paid up capital of £352,790, and many branches, stopped payment during the pressure in November 1836, and by doing so involved many persons in great distress. It appears to have been extremely ill-managed. The auditors appointed to examine into its affairs reported—"Its book-keeping has been found to be so faulty, that we are convinced no accurate balance-sheet could at any time have been constructed."

<sup>1</sup> *Observations on Paper Money, &c.*, by Sir Henry Parnell, p. 171.

And they significantly added—"the personal accounts at the head office require a diligent and searching revision."

The Tipperary Joint-Stock Bank, which was established in 1839, and stopped payments in 1855, appears to have been little, if at all, better than a mere swindling engine. Luckily it did not issue notes; and the sphere of its operations was not very extensive. But, so far as its influence went, nothing could be worse, being ruinous alike to the majority of its partners and to the public.

We have in the previous section on Scotch banks mentioned the fact of the establishment by the National Bank

of Ireland of a head office and of several branches in London. This example has been so far followed by the Provincial Bank that it has also set up a head office in London, without, however, competing for general business in the metropolis. An addition was made to the number of Irish banks in 1864 by the establishment of the Munster Bank (Limited), having its head office in Cork. It has established upwards of 40 branches, and pays a dividend of 12 per cent. to its shareholders.

We borrow principally from Thom's *Irish Almanac*, the most valuable publication of its class, the following details with respect to the Irish banks in 1875:—

*Account of Joint-Stock Banks existing in Ireland in 1875, their Branches, Capital, Fixed Issues, &c.*

Instituted.	BANKS	No. of Branches.	Subscribed Capital.			Paid up Capital.		Latest Dividend per Annum declared.	Reserve Fund and Balance after last Dividend.
			No. of Shares.	Per Share.	Amount.	Per Share.	Amount.		
1783	Bank of Ireland ( <i>Dublin</i> ).....	49	Stock.	£ 100	2,769,230	£ 100	2,769,230	Per cent. 12	£ 1,072,000
1827	Belfast Banking Company ( <i>Belfast</i> ).....	35	5,000	100	500,000	25	125,000	20	135,966
	( <i>New Shares</i> ).....		5,000	100	500,000	25	125,000	8	..
1824	Hibernian Joint-Stock Banking Company ( <i>Dublin</i> ).....	31	20,000	100	2,000,000	25	500,000	12	235,000
1864	Munster Bank, Limited ( <i>Cork</i> ).....	41	100,000	10	1,000,000	3½	350,000	12	170,000
1835	National Bank ( <i>London</i> ).....	109	50,000	50	2,500,000	30	1,500,000	11	133,000
1825	Northern Banking Company ( <i>Belfast</i> ).....	43	5,000	92/6/2	461,638	30	150,000	15	170,000
	( <i>New Shares</i> ).....		5,000	100	500,000	30	150,000	7½	..
1824	Provincial Bank of Ireland ( <i>London</i> ).....	41	20,000	100	2,040,000	25	540,000	20	254,181
			4,000	10	..	10	..	..	..
1836	Royal Bank of Ireland ( <i>Dublin</i> ).....	4	30,000	50	1,500,000	10	300,000	15	196,000
1836	Ulster Banking Company ( <i>Belfast</i> ).....	41	100,000	10	1,000,000	2½	250,000	20	287,500

#### *Bank of Amsterdam.*

The Bank of Amsterdam was founded in 1609, on strictly commercial principles and views, and not to afford any assistance, or to intermeddle with the finances of the state. Amsterdam was then the great entrepôt of the commerce of the world, and of course the coins of all Europe passed current in it. Many of them, however, were so worn and defaced as to reduce their general average value to about 9 per cent. less than their mint value; and, in consequence, the new coins were immediately melted down and exported. The currency of the city was thus exposed to great fluctuations; and it was chiefly to remedy this inconvenience and to fix the value or par of the current money of the country, that the merchants of Amsterdam established a "bank," on the model of that of Venice. Its first capital was formed of Spanish ducats or ducatoons, a silver coin which Spain had struck in the war with Holland, and with which the tide of commerce had enriched the country it was formed to overthrow. The bank afterwards accepted the coins of all countries, worn or new, at their intrinsic value, and made its own bank-money payable in standard coin of the country, of full weight, deducting a "brassage" for the expense of coinage, and giving a credit on its books, or "bank-money," for the deposits.

The Bank of Amsterdam professed not to lend out any part of the specie entrusted to its keeping, but to retain in its coffers all that was inscribed on its books. In 1672, when Louis XIV. penetrated to Utrecht, almost every one who had an account with the bank demanded his deposit, and these were paid off so readily that no suspicion could exist as to the fidelity of the administration. Many of the coins then brought forth bore marks of the confiscation which happened at the Hôtel de Ville, soon after the establishment of the bank. This good faith was maintained till about the middle of last century, when the managers secretly lent part of their bullion to the East India Company and Government. The usual "oaths of

office" were taken by a religious magistracy, or rather by the magistracy of a religious community, that all was safe, and the good people of Holland believed, as an article of their creed, that every florin which circulated as bank-money had its metallic constituent in the treasury of the bank, sealed up, and secured by oaths, honesty, and good policy. This blind confidence was dissipated in December 1790, by a declaration that the bank would retain 10 per cent. of all deposits, and would return none of a less amount than 2500 florins.

Even this was submitted to and forgiven. But, four years afterwards, on the invasion of the French, the bank was obliged to declare that it had advanced to the States of Holland and West Friesland, and the East India Company, more than 10,500,000 florins, which sum it was, of course, unable to make up to the depositors, to whom, however, it assigned its claims on the states and the company. Bank-money, which previously bore an agio of 5 per cent. immediately fell to 16 per cent. below current money.

This epoch marked the fall of an institution which had long enjoyed an unlimited credit and had rendered the greatest services. The amount of treasure in the vaults of the bank, in 1775, was estimated by Mr Hope at 33,000,000 florins.<sup>1</sup>

#### *The Bank of France.*

This bank, second in magnitude and importance to the Bank of England only, was originally founded in 1800, but was not placed on a solid and well-defined basis till 1806. Its capital, which was originally fixed at 45,000,000 fr., was raised in the last-mentioned year to 90,000,000 fr., divided into 90,000 shares or *actions*, of 1000 fr. each. Of these shares, 67,900 have passed into the hands of the public; the remaining 22,100, having been purchased up by the bank out of its surplus profits, were subsequently

<sup>1</sup> Storch, *Cours d'Economie Politique*, tom. iv. p. 102.

cancelled. Hence its capital amounted, down to 1848, to 87,900,000 fr. (£2,716,000), with a reserve fund, first of 10,000,000 fr., and more recently of 12,980,750 fr. Since 1806 the bank has enjoyed the privilege of being the only institution in Paris entitled to issue notes payable on demand, and, as will be afterwards seen, it is now the only authorized issuer of such paper in France. Its charter and exclusive privileges have been prolonged and varied by laws passed at different periods.

The bank has established, at different periods since 1817, offices or branches (*succursales*) in different parts of the country. They are managed nearly in the same way as the parent establishment; but their operations were long on a comparatively small scale. These are exclusive of the departmental banks united, as will be immediately seen, to the bank in 1848.

Notwithstanding the skill and caution with which its affairs have generally been conducted, the revolution of 1848 brought the bank into a situation of extreme danger. It had to make large advances to the Provisional Government and the city of Paris. And these circumstances, combined with the distrust that was universally prevalent, occasioned so severe a drain upon the bank for gold, that to prevent the total exhaustion of its coffers, it was authorized, by a decree of the 16th March 1848, to suspend cash payments, its notes being at the same time made legal tender. But to prevent the abuse that might otherwise have taken place under the suspension, the maximum amount of its issues was fixed at 350 millions. The bank was then also authorized to reduce the value of its notes from 500 fr. to 200 and 100 fr.

Previously to 1848, joint-stock banks, on the model of that of Paris, and issuing notes, had been established in Lyons, Marseilles, Bordeaux, Rouen, and other large cities. And it was then determined that these banks should be incorporated with the Bank of France, and made branches of the latter. This was effected by decrees issued on the 27th April and 2d May 1848, by which the shareholders of the banks referred to (nine in number) were allowed, for every 1000 fr. nominal value of their shares, a share of 1000 fr. nominal value of the stock of the Bank of France. And, in consequence of this measure, 23,351 new shares, representing a capital of 23,351,000 fr., were added to the stock of the Bank of France, making the latter consist of 91,250,000 fr. divided into 91,250 shares. In 1851 the bank resumed specie payments.

The suppression of the local issues of the departmental banks was, no doubt, a judicious measure, and was indispensable, indeed, to secure the equal value of the paper circulating in different parts of the country. This, however, might have been effected by the mere stoppage of the issues of the departmental banks, without consolidating them with the Bank of France. The latter measure is one of which the policy is very questionable; and there are, as already seen, good grounds for thinking that the banking business of the departments would have been more likely to be well conducted by local associations, than by branches of the Bank of France. Constant additions have been made to the number of branches, which now exceeds seventy.

Owing to the war with Russia, and still more to the rage for speculation, and the drain for silver to the East that followed it, the Bank of France became exposed to considerable difficulties. And in the view of strengthening its position, and also, it may be presumed, of providing a loan for Government, a law was passed (9th June 1857), by which the capital of the bank was increased from 91,250 shares of 1000 fr. each to 182,500 shares of 1000 fr. each. The new shares were assigned to the existing proprietors at the rate of 1100 fr. per share, producing a

total sum of 100,375,000 fr., of which 100 millions were lent to Government at 3 per cent. Hence the measure, though it added to the credit and security of the bank, made no addition to the means directly at its disposal.

Down to the passing of this law, the bank could not raise the rate of interest on loans and discounts above 6 per cent. But this impolitic restriction was removed, and the bank authorized to charge any rate of interest which she reckoned expedient, except upon advances to Government, the maximum interest on which was limited to 3 per cent. The bank was farther authorized to issue notes of the value of 50 fr., to make advances on railway shares, &c., and the charter was extended to 1897.

The management of the Bank of France was severely tried in the latter part of 1864 by the occurrence of a financial crisis at Paris; and in January 1865 a commission of inquiry was appointed to examine into the principles and practice of banking. There was, however, nothing mysterious or exceptional in the experience of 1864. Speculation had been much stimulated in France by the establishment of companies (*Crédit Foncier, Crédit Mobilier, &c., &c.*) for the undertaking of public works, and much capital was locked up and more pledged towards the completion of enterprises supposed at first to be highly profitable, but in reality offering a distant and doubtful promise of remuneration. The crisis of 1864 was the dissipation of these delusions, and the voluminous publications of evidence and opinion by the commission of inquiry produced no practical consequences.

The war of 1870-71 could not but have an important influence on the operations of the bank. Successive Governments resorted to it for assistance, which was obtained by increasing the issue of its notes and by giving them a forced currency. The rate of interest, which had been 2½ per cent. from May 1867, rapidly rose to 6 and 6½, at which it remained with scarcely any variation from 9th August 1870 till late in the year 1872. The rate would probably have risen much higher, but on the 13th August a law was approved suspending the liability of the acceptors of bills current to meet them at maturity, and this suspension was renewed until it was finally withdrawn in July 1871. The amount of unpaid bills held by the bank reached a maximum of 368 millions of francs, but the ultimate loss was extremely small. On the 23d June 1870 the metallic reserve at the bank was 1318½ millions of francs, which was reduced to a minimum of 505 millions on the 24th December of the same year. The notes in circulation before the war had been about 1400 millions of francs; but before the end of the year 1870 their volume had increased to 1700 millions; and this again rose to 2000 millions before July 1871, and to 2400 millions before the end of 1871. A law of the 29th December 1871 fixed the maximum at 2800 millions, which was finally raised on 15th July 1872 to a maximum of 3200 millions. The debt of the state to the bank increased concurrently with this increase of issues, which was, indeed, authorized for the purpose of enabling the bank to assist the treasury. On the 26th December 1870 the bank held treasury "bons" to the extent of 174,800,000 francs only, but on the 30th November 1871 it held 1,193,600,000 of these "bons," and in August 1872 the amount reached 1,363,100,000 francs. A law of the 21st June 1871, followed by an agreement between the bank and the Government, provided for the repayment of this debt in annual payments of 200 millions, but up to this time (August 1875) the income of the state has never been large enough to provide the whole of this sinking fund. The bank has, however, been able to increase its metallic reserve through the liquidation of securities and the accumulation of deposits; so that, after having been reduced,

as we have said, to 505 millions in December 1870, and not attaining to more than 634 millions in December 1871, it rose in the same month of 1872 to 793 millions, in 1873 to 820 millions, and in 1874 to 1331, or just the amount at which it stood before the declaration of war. Its volume has, however, continued to increase, and on the 25th March of this year (1875) it stood at 1528 millions; and the forced currency of the notes of the bank might be at any time withdrawn. It must be admitted that the management of the bank throughout these years of difficulty has been eminently prudent and successful.

The bank is obliged to open a *compte courant* for any one who requires it, and performs services, for those who have such accounts, similar to those performed for their customers by the banks in London. The bank does not charge any commission on current accounts, so that its only remuneration arises from the use of the money placed in its hands by the individuals whose payments it makes. It is probable, therefore, as has been alleged, that this part of the business is but little profitable. The bank also discounts bills with three signatures at variable dates, but not having more than three months or ninety days to run. Besides discounting bills, the bank makes advances on stocks and pledges of various kinds, and undertakes the care of valuable articles, such as plate, jewels, title-deeds, &c., at a charge of  $\frac{1}{2}$  per cent. on the value of the deposit for every period of six months and under.

The administration of the bank is vested in a council of twenty-one members, viz., a governor and two sub-governors, nominated by the chief of the state, and fifteen directors and three censors, nominated by the shareholders. The bank has a large surplus capital or rest. In 1848 the dividends only amounted to 75 fr. per share. In 1855 and 1856 they were 200 and 272 fr. on each share. In 1870 they fell to 114 fr., but rose again to 300 fr. in 1871, and to 320 fr. in 1872. In July 1856 the 1000 fr. share of bank-stock was worth 4075 fr.; in July 1857 it had sunk to 2880 fr. It is now (1875) worth about 3850 fr.

*Banking in the United States.*

Before the late Civil War it had been the uniform practice of the different States of the Union to allow banks to be established for the issue of notes, payable in specie on demand. In cases where the liability of shareholders in banks was to be limited to the amount of their shares, they had, previously to 1838, to be established by Acts of the local legislatures; but, in general, these were easily obtained, and it may be said that banking was quite free, and that, practically, all individuals or associations might issue notes, provided they abided by the rules laid down for their guidance, and engaged to pay them when presented.

Under this system the changes in the amount and value of the paper currency of the United States were greater than in any other country, and it produced an unprecedented amount of bankruptcy and ruin.

Between 1811 and 1820, about 195 banks, in different parts of the Union, became bankrupt; and it is said, in a report by the Secretary of the Treasury of the United States, dated 12th May 1820, that these failures, which mostly happened in 1814 and 1819, produced a state of distress so general and severe that few examples of the like had then occurred.

But bad as this instance was, it was nothing to that which took place subsequently to 1834. The accounts of the aggregate issues of the banks differ a little; but the following statement is believed to be very nearly accurate, viz:—

Years.	Notes.
1830	\$66,623,898
1834	94,839,570
1835	103,692,495
1836	140,310,638
1837	149,185,890

Now observe, that this sudden and enormous increase took place under the obligation which we are told is quite enough to prevent all abuse of paying notes on demand. The result was what most men of sense must have anticipated, viz., that a revulsion took place, and that every bank within the Union, without, it is believed, a single exception, stopped payment in 1837.

In 1838 such of the banks as had been best managed and had the largest capitals resumed payment in specie. But in 1839 and 1840 a farther crash took place; and the bank-notes afloat, which, as has been seen, amounted to \$149,185,890 in 1837, sunk to \$83,734,000 in 1842, and to \$58,563,000 in 1843. It is supposed that in this latter crash nearly 180 banks, including the Bank of the United States, were totally destroyed. And the loss occasioned, by the depreciation which it caused in the value of stocks of all kinds and of all sorts of property, was quite enormous. And yet, vast as that loss was, it was really trifling, as a writer in the *American Almanack* has stated, compared with "the injury resulting to society from the upheaving it occasioned of the elements of social order, and the utter demoralization of men by the irresistible temptation to speculation which it afforded, ending in swindling to retain ill-gotten riches."

The evils of the American system were aggravated by the lowness of the notes which most banks issued. This brought them into the hands of retail traders, labourers, and others in the humbler walks of life, who always suffer severely by the failure of a bank.

After 1838 and 1842 various measures were taken in nearly all the States, but principally in New York, to restrain the free action of the banks, and to prevent a repetition of the calamities referred to.

In New York, for example, banks were divided into two great classes—the incorporated and the free banks. The former, incorporated by a State law, had to conform to certain regulations, and to contribute a half per cent. annually upon their capital to a security fund, which was devoted to the payment of the notes of defaulting banks. But this was a most objectionable plan; for, in the first place, it did not prevent bankruptcies, and, in the second place, it compelled the well-managed banks to contribute to a fund which went to pay the debts of those that were mismanaged. It consequently declined in favour, and soon became rarely acted upon.

In the other or free banking system, all individuals or associations who chose to deposit securities (minimum amount, \$100,000); for their payment were allowed to issue an equal amount of notes. And this was certainly by far the more efficient as well as the more popular of the two plans. It was, however, not free from objection; because, 1st, A longer or shorter, but always a considerable, period necessarily elapsed after a bank stops before its notes can be retired; and, 2d, The securities lodged for the notes were necessarily at all times of uncertain and fluctuating value, while, in periods of panic or general distrust, they became all but inconvertible. The Sub-Secretary of the Treasury of the United States animadverted as follows on this plan, in a letter dated 27th Nov. 1854:—

"The policy of many of the State Governments has of late years consisted in encouraging the issue of small notes, by sanctioning the establishment of what are popularly called 'free banks,' with deposits of stocks and mortgages for the 'ultimate' security of their issues. This 'ultimate' security is, it may be admitted, better than no security at

all. The mischief is, that it is least available when most wanted. The very causes which prevent the banks from redeeming their issues promptly, cause a fall in the value of the stocks and mortgages on 'the ultimate security' of which their notes have been issued. The 'ultimate' security may avail something to the broker who buys them at a discount, and can hold them for months or years; but the labouring man who has notes of these 'State security banks' in his possession, finds, when they stop payment, that 'the ultimate security' for their redemption does not prevent his losing twenty-five cents, fifty cents, or even seventy-five cents in the dollar.

"In a circulating medium we want something more than 'ultimate security.' We want also 'immediate' security; we want security that is good to-day, and will be good to-morrow, and the next day, and for ever thereafter. This security is found in gold and silver, and in these only."<sup>1</sup>

The Report of the Superintendent of Banking for the State of New York for 1856 showed that the securities he then held in trust amounted to \$39,359,071, which were almost wholly lodged by banking associations and individual bankers.

During the year the securities held in trust for the undermentioned banks that had become insolvent in 1855 were disposed of. But the sums realized by their sale did not in any case suffice to pay the notes at par; while a period, varying from two to four years, would have to elapse before the affairs of the insolvent banks were finally settled.

Names of Banks that failed.	Notes redeemed.	Rate of Redemption.	Expiration of Time for Redemption.
Eighth Avenue Bank .....	All .....	94 cents.	May 21, 1861.
Farmers' Bank, Onondaga.	All .....	85 cents.	Nov. 12, 1859.
James' Bank .....	All .....	91 cents.	June 17, 1858.
Merchants and Mechanics' Bank, Oswego .....	All .....	77 cents.	Sept. 28, 1860.
New Rochelle, Bank of .....	Stock notes.	Par .....	June 17, 1858.
New Rochelle, Bank of .....	Stock and estate notes.	81 cents.	June 17, 1858.

This statement set the defective nature of the security system, as administered in New York, in the clearest point of view. It might, no doubt, have been improved by increasing the proportion of securities to notes. But, owing to the variety of securities that were taken (*vis.*, all manner of bonds and mortgages, state, canal, and railway stocks, &c., &c.), and the uncertainty of their value, a great deal of risk was always incurred in accepting them, and they could never form a proper foundation on which to issue notes.

In 1857 another crash took place, and *all* the banks in the Union, from the Gulf of Mexico to the frontiers of Canada, again stopped payments.

There had been a rapid increase of discounts since 1851, and that increase was especially great in 1856, and went on augmenting down to August 1857. On the 8th of that month the discounts and advances by the New York banks amounted to \$122,077,252, the deposits in their possession being, at the same time, \$94,436,417. This was the maximum of both. On the 24th of August the Ohio Life and Trust Company, which carried on an extensive banking business in New York, stopped payments, and by so doing gave a severe shock to credit and confidence, which the suspension of two or three more banks turned into a panic. Notes being in a certain degree secured, the run upon the banks was principally for deposits. And to meet it they so reduced their discounts and advances, that, on the 17th October, they amounted to only \$97,245,826. This sudden

and violent contraction necessarily occasioned the suspension of many of those mercantile houses that had depended on the banks for discounts. And it did this without stopping the drain for deposits, which had sunk, on the 17th October, to \$52,894,623, being a decrease of \$41,546,784 in about two months. The universal stoppage of the banks was a consequence of these proceedings.

The Civil War had as one of its consequences the introduction of a general banking law in the United States, conformable in many respects to the principles of what we have described as the free banking law of New York. At the beginning of the war in 1861, the amount of paper money in circulation was about \$200,000,000, of which \$150,000,000 had been issued in the loyal States; and the coin in circulation was estimated at \$275,000,000. The necessities of the Treasury very soon compelled the Government to borrow from the associated banks of New York, Philadelphia, and Boston, and to issue demand-notes to the extent of \$50,000,000,—which, however, were not at first made legal tender. In February 1862 an Act was passed by Congress authorizing the issue of \$150,000,000, in Treasury notes of not less than \$5 each, out of which, however, \$50,000,000 were in lieu of the notes already issued; and this issue was declared to be legal tender except in discharge of customs' duties, and of the payment of interest by the United States on the national debt. It will be easily understood that coin went out of circulation, and a premium on gold was established, which increased as the amount of the Treasury notes was increased by successive legislation, and as national bank-notes came to be issued in pursuance of the law we must proceed to describe. This is the Banking Law of the 25th February 1863, which, as amended by the Act of the 3d June 1864, now continues in force. By this law a Currency Bureau and Comptroller of Currency were appointed in the Treasury Department, with the power to authorize banking associations of not less than five persons subscribing, except in very small towns, a minimum capital of \$100,000, 50 per cent. to be paid up at once, and the remainder within six months. It was enacted that any such association, before commencing business, must transfer to the Treasurer of the United States any United States interest-bearing bonds not less than one-third of the capital stock, and should thereupon receive from the Comptroller of the Currency circulating notes of different denominations in blank, registered and countersigned, equal in amount to 90 per cent. of the current market value of the bonds so transferred, but not exceeding their par value. The whole amount of notes thus issued was not to exceed \$300,000,000, one-half to be apportioned among the States according to their representative population, and the other half to be apportioned with regard to the existing banking capital, resources, and business of the States.

The banks already existing in the several States were rapidly transformed into national banks under the operation of this law, and their previous notes withdrawn in exchange for the new national bank issue. The currency of the Union thus came to consist of the demand-notes of the Treasury, which rose in 1865 to about \$450,000,000, and of the notes of the national banks, which rapidly approached the limit of \$300,000,000,—the latter notes passing throughout the Union, whatever the bank through which they were issued, as freely as the former, since the ultimate payment of them was secured by the deposit under the law we have stated, of an adequate amount in United States' bonds at the Treasury. It is not our purpose to trace the subsequent financial history of the States, but the experience of 1873 must be referred to for the instruction it affords. As no sufficient steps were taken after the termination of the war to reduce the swollen value of the

<sup>1</sup> The above statements are taken from a paper read by Lord Overstone to the Committee on Banks.



currency, gold remained out of circulation, though with the growth of business the premium on it declined to an average rate of 12 per cent.; but no inconvenience was felt from the existence of a pure paper circulation, and the opinion, in fact, arose that the currency thus established was a sure preventive of recurrent panics and exaggerated rates of discount. But in September 1873 the financial house of Jay, Cooke, & Co., having locked up a large amount of capital in railway enterprises not immediately if ever likely to be productive, suspended payments; other financial houses were forced to take the same step, several banks closed their doors, and a severe panic set in. The holders of the notes in circulation of the banks that failed were protected by the deposit of bonds at the Treasury, and the notes were never discredited; but the financial distress throughout the Union was excessive, and continued for many months. It was practically demonstrated that the national bank law protected the holders of national bank-notes from loss, but afforded no immunity against the occurrence of financial crises.

#### *Banking in Germany.*

Banking in Germany, up to the close of the Franco-German War, presented no peculiar features requiring attention. The Bank of Hamburg was established in 1619, on the model of that of Amsterdam, as a purely deposit bank for the transfer of sums from the account of one individual to that of another; and its management appears to have been uniformly good. In the several German States banks were authorized under laws peculiar

to each; and most of them were allowed to issue notes according to regulations varying from State to State. It followed that the notes of each bank were confined to its own neighbourhood; but the establishment of German unity was followed by a demand for a general banking law, and the establishment of a note currency that might circulate throughout the empire. After some discussion the Act of the 30th January 1875 was passed to satisfy these demands. Under this law an Imperial Bank was established, with an uncovered issue of 250 millions of marks (= £12,500,000); and thirty-two banks were recognized as possessing rights of uncovered issue to the extent of 135 millions of marks (£6,750,000). The Imperial Bank is, however, allowed to increase its issue, subject to the condition that at least one-third is represented by cash in hand, and the remaining two-thirds by bills not having more than three months to run; while the other banks may also exceed their authorized issues subject to the payment of 5 per cent. interest on the excess above the authorized limit, plus the cash in hand, and weekly returns are required of the amount in circulation. No note is to be less than 100 marks (£5), and no new right of issue can be conceded except by a law of the empire. The State itself, however, under a law of April 1874, has the right to issue 120 millions of marks in State notes of small denominations. The working of this law has not yet been tested; but, if we may judge from our own experience, it will not produce any rapid withdrawal of local issues, and the unification of the note currency of the empire will not be accomplished. (L. H. C.)

**BANKRUPTCY.** When a person is unable to pay his debts in full, the law of civilized countries adopts some means of satisfying the creditors, as far as they can be satisfied, out of the debtor's estate, and relieving the debtor himself from pressure which, by his own efforts, he would not be likely to overcome. The debtor having been declared a bankrupt, his property vests in his creditors for the purpose of being rateably divided among them, and he thereupon starts a new man, entirely relieved from the obligations thus partially satisfied. Such, in general terms, is the process of bankruptcy as observed in modern societies. The law of bankruptcy is, in fact, a modern creation, slowly evolved out of the criminal code in answer to the necessities of a widely-spread industrial life. Early society is unanimous in treating inability to fulfil legal obligations as a most serious offence; and the harshness of ancient law towards debtors has been explained as a consequence of the fact that a contract was at first regarded as a sort of incomplete conveyance, and creditor and debtor as persons who respectively had and had not fulfilled their legal obligations. The early law of Rome, while prohibiting contracts of usury, still gives the legal creditors the savage remedy of dividing the carcass of their debtor or selling him and his family into slavery. Severe commercial distress endangering the stability of the state is of frequent occurrence in the history of Rome; but the law against debtors long retained its primitive severity. The *Lex Poetelia* (about 326 B.C.) enabled a debtor, who could swear to being worth as much as he owed, to save his freedom by resigning his property; and many years after the legislation of Julius Cæsar established the *cessio bonorum* as an available remedy for all honest insolvents. The slow development of the law, and the practical difficulties with which each new adjustment was met, are copiously illustrated by the history of bankruptcy legislation in England. The first English statute on bankruptcy (34 and 35 Hen. VIII. c. 4) was directed against *fraudulent*

*debtors*, and gave power to the lord chancellor and other high officers to seize their estates and divide them among the creditors. The 13 Elix. c. 7 restricted bankruptcy to *traders*, and prescribed certain acts by committing which a trader became a bankrupt. Commissioners appointed by the lord chancellor are to seize the person of the bankrupt and divide his property among the creditors. The 4 Anne c. 17 and 10 Anne c. 15 took away the criminal character hitherto borne by the proceedings, and allowed a debtor, with the consent of a majority of his creditors, to obtain a certificate of having conformed to the requisitions of the bankrupt law, which, when confirmed by the chancellor, discharged his person and his after-acquired property from debts due by him at the time of his bankruptcy. The 6 Geo. IV. c. 16 allows a debtor to procure his own bankruptcy (an arrangement previously regarded as fraudulent), and introduces the principle of deeds of arrangement between debtor and creditors without a public bankruptcy. The 1 and 2 Will. IV. c. 56 established the Court of Bankruptcy, consisting of six commissioners, along with four judges as a Court of Review, and appointed official assignees to get in the bankrupt's estate on behalf of the creditors.

Various other statutes in the next twenty years made unimportant changes in the constitution of the court. In 1847 jurisdiction in bankruptcy was again restored to the Court of Chancery by the appeal being transferred to that court. The Bankrupt Law Consolidation Act, 1849, effected several important alterations in the system. Proceedings were to begin by a petition to the Court of Bankruptcy instead of a fiat out of Chancery. The commissioners were authorized to award certificates, classified according to the merit of the bankruptcy. In the first class the insolvency was declared to be due to misfortune, in the second, not entirely to misfortune; and in the third, not at all to misfortune. Certain specified offences deprived the bankrupt of all right to a certificate, and made him

liable to a criminal prosecution. The object of this arrangement was, of course, to meet fraudulent, or not entirely honest, attempts to obtain the benefit of a discharge of debts under the bankruptcy laws. It was not entirely successful, inasmuch as there was no settled principle observed in classifying the certificates, and the lowest class was, for all practical purposes, as good as the highest. The Act of 1849 also encouraged private arrangements by making a composition, accepted by nine-tenths of a bankrupt's creditors, binding upon the rest; but it was decided subsequently by the courts that, to make such a composition binding, it must be accompanied by a complete *cessio bonorum*. The next statute, the Bankruptcy Act, 1861, made non-traders subject to the law of bankruptcy, and empowered a majority in number, and three-fourths in value, of the creditors to bind the minority without a *cessio bonorum*. This arrangement was found to lead to private and fraudulent compositions, and in consequence by an Amendment Act in 1868 enlarged powers were given to non-assenting creditors. All this legislation still failed to give complete satisfaction. The complete exoneration of after-acquired property was denounced as unfair and likely to invite fraudulent bankruptcies, the system of arrangements with creditors was disliked, and the control of creditors over the property of the debtor and proceedings in bankruptcy was felt to be too small. The Bankruptcy Act, 1869, was passed after many unsuccessful attempts to deal with these complaints. It established a new Court of Bankruptcy, consisting of a chief judge, registrars, and other officers. The commissionerships were abolished, and the subordinate staff was to be transferred to the new court. The chief judge in bankruptcy is to be a judge of one of the Superior Courts of Law and Equity; and hitherto the office has been held by one of the acting vice-chancellors. Appeals from the county courts in bankruptcy go to the chief judge, and appeals from the chief judge to the Court of Appeal in Chancery, and thence occasionally to the House of Lords. Official assignees were abolished; and trustees, who should be creditors, are to be appointed to distribute the bankrupt's estate, while the creditors may appoint a committee of inspection to superintend the operations of the trustees. A comptroller in bankruptcy will receive the trustees' accounts after they have been audited by the committee, and take notice of any irregularity in the proceedings of the trustees. The law of reputed ownership was restricted to traders. Voluntary settlements by a trader, except in the case of property accrued in right of his wife, are void as against the trustee if the settler becomes bankrupt within two years after the settlement; and if he becomes bankrupt within ten years, it must be shown that, at the time of the settlement, he had sufficient property besides to pay his then existing debts, otherwise the settlement becomes void. A covenant by a trader, although made in consideration of marriage, for future settlement of property not then in any way belonging to him, is void as against the trustee, unless the property has been transferred or paid before the bankruptcy. The Act also introduces important alterations as to the discharge of the bankrupt. A bankrupt will not be discharged unless his estate has paid ten shillings in the pound, or a majority of the creditors (three-fourths in value) declare that the bankrupt is not responsible for the deficiency, and that they desire his discharge. If within three years the bankrupt makes up the dividend of ten shillings in the pound, he may have his discharge; and in the meantime his property will be protected from the creditors of the bankruptcy. If he fails to make up this dividend within three years, any debt remaining unpaid will become enforceable against his after-acquired property,—subject, of course, to the rights of creditors subsequent to the bankruptcy. There are provisions for

compromising the bankruptcy by composition or liquidation by arrangement. The usual criminal clauses have been separated from the new statute of bankruptcy and appear in a separate enactment,—the Debtors' Act, 1869,—and the Court of Bankruptcy has no longer any criminal jurisdiction whatever. The Debtors' Act abolishes imprisonment for debt (except in certain cases in which the debt is mostly of the nature of a penalty), and provides for the punishment of certain misdemeanours of fraudulent debtors, whose affairs have come into bankruptcy. The prosecution takes place before the ordinary criminal tribunals. The Bankruptcy Act and the Debtors' Act become—by the repeal of previous statutes relating to insolvency, bankruptcy, and imprisonment for debt—a complete record of the legislation now in force on this subject.

Under the new statute all the county courts are constituted local courts of bankruptcy, while for the London district, as defined in the Act, there is the London Bankruptcy Court. All these courts are presumed to be the same court, and cases may be transferred from one to the other if necessary. Subject to this power of transfer, proceedings are to be taken against a debtor in the court of the district in which he resides; and if he does not reside in England and Wales, in the London court. By order of that court, or by resolution of the creditors, or by certificate of the local judge, cases may be transferred to the London court from any of the local courts. The chief judge, or a local judge, may delegate the powers (except the power of committing for contempt) to the registrar. All the courts of bankruptcy and their officers in England are to act in conjunction with bankruptcy courts in Scotland and Ireland, and with British courts having jurisdiction in bankruptcy elsewhere, the orders of one court being enforceable within the jurisdiction of the others. Section 72 of the Act gives to the new Court of Bankruptcy the important power "to decide all questions of priority, and all other questions of law or fact arising in any case of bankruptcy coming within the cognizance of such court, or which the court may deem it expedient or necessary to decide, for the purpose of doing complete justice or making a complete distribution of property in any such case." By this enlarged jurisdiction the court has power to decide, even as against strangers, questions arising in the bankruptcy; and it has been held that it may restrain proceedings in Chancery or at Common Law, and even out of the jurisdiction. The judge may, at the request of parties, or of his own discretion, direct issues of fact to be tried by a jury.

By the Bankruptcy Act, 1861, the special legislation relating to insolvent debtors was abolished. Up to that time *traders* only had been allowed the relief of bankruptcy, and all other insolvent debtors remained liable to their creditors for the unpaid portion of their debts. They might be kept in prison during the creditor's pleasure, and any property they might acquire was available for the satisfaction of the creditors' claims. From time to time special Acts were passed for the liberation of insolvent debtors confined in prison, a general Act (53 Geo. III. c. 102) was tried for a limited period and repeated, and finally, by 1 and 2 Vict. c. 110, a court was established for the "relief of insolvent debtors," their discharge, of course, being conditional on the surrender of their property for the benefit of their creditors. The principle of the distinction thus maintained between the trader and the non-trader was, that the creditors of the former were to be regarded as to some extent partners in his speculations, while the latter was alone responsible for his insolvency; and it was feared that the discharge of bankruptcy, if allowed as a means of satisfying private debts, might give great encouragement to extravagance and fraud. On the abolition of the

Insolvent Court in 1861, all insolvent debtors were admitted to the relief of bankrupt's discharge, but a distinction is still made on several important points between traders and non-traders. A schedule to the Act of 1860 gives a list of the different occupations which are to be considered as "trades," and the exception is expressly stated that "a farmer, grazier, common labourer, or workman for him, shall not, nor shall a member of any partnership, association, or company, which cannot be adjudged bankrupt under this Act, be deemed as such a trader for the purposes of this Act." The liability to bankruptcy may therefore be said to be now almost co-extensive with the capacity to make a contract. Persons who cannot make a binding contract, e.g., married women, minors, lunatics, &c., cannot be made bankrupts. But where this incapacity is removed (as for example in the city of London, where by custom a married woman may trade as a *femme sole*), the liability to bankruptcy will arise.

Proceedings in bankruptcy are now begun by a petition from one or more creditors (claiming not less than £50), alleging that the debtor in question has committed an act of bankruptcy, and praying that he may be adjudged a bankrupt. The following are "acts of bankruptcy:"—

- (1.) If the debtor has assigned his property to trustees for the benefit of his creditors; or (2), has made a fraudulent conveyance of any of his property; or (3), with intent to defraud his creditors, has departed from or remained out of England; or, being a trader, has left his dwelling-house, or begun to keep house, or suffered himself to be outlawed; or (4), has filed a declaration of inability to pay his debts; (5.) If execution for not less than £50 has been levied by seizure of goods (in the case of a trader); (6.) If the creditor has served a "debtors' summons" for not less than £50, and the debtor has for three weeks (or if a trader, for seven days) neglected to pay or compound for the same. The adjudication must be asked for within six months of the act of bankruptcy, and the petitioning creditor's debt must be for a liquidated (i.e., ascertained) sum due at law or in equity, and must not be a secured debt unless the security is given up for the benefit of the creditors. Should the alleged debtor deny his indebtedness, the court may dismiss the summons or direct the issue to be tried by itself or some other competent court; and similar proceedings take place when the debtor appears to the creditors' petition and repudiates his indebtedness.

The consequence of adjudication is that all the bankrupt's property vests in the registrar of the court, until the appointment by the creditors of a trustee, and thereafter in the trustee. The word property has been expressly defined to include money, goods, things in action, land, and every description of property, whether real or personal, also obligations, ornaments, and "every description of estate, interest, and profit, present or future, vested or contingent, arising out of, or incident to, property as above defined." The adjudication "relates back" to the time of the "act of bankruptcy." The bankrupt may retain the tools of his trade and the necessary clothing and bedding of his family to the extent in all of £20. It is the duty of the trustee to discover, take possession of, realise, and distribute the bankrupt's property; and, subject to the provisions of the Bankruptcy Act, he must follow the directions of the committee of inspection or the creditors. The bankrupt is required to aid in the administration. He must procure a statement of his affairs, and submit to a public examination thereon. A bankrupt under examination is not, like a witness in other courts, protected from questions tending to inculcate himself, although he cannot be compelled to answer a question whether he has done some specific act clearly of a criminal nature. His answers may afterwards be used as evidence against him on a criminal charge.

The bankrupt cannot now be arrested or imprisoned except for attempts to leave the country, avoid appearance, remove or conceal his goods, &c., or, after adjudication, for removing goods above the value of £5, or failing to attend examination, or committing contempt of court. If a member of the House of Commons is adjudged bankrupt, he becomes incapable of sitting or voting for one year after the adjudication, unless within that time the bankruptcy is annulled or the creditors satisfied. If on the expiration of a year neither of these events has taken place, the court certifies the fact to the speaker, and the seat of the bankrupt member thereupon becomes vacant. A bankrupt peer is disqualified from sitting or voting in the House of Lords, unless and until his bankruptcy is annulled on the ground that the order of adjudication ought not to have been made, or the bankrupt is discharged by actual payment or satisfaction in the prescribed mode from all debts and liabilities due at the date of his bankruptcy. The conditions on which a bankrupt may obtain his discharge have been already stated. The discharge releases the bankrupt for all debts provable under the bankruptcy, except debts due to the Crown, or for offences against the revenue, and debts incurred by means of fraud or breach of trust. The court has power to annul the bankruptcy on various grounds, but in that case all acts properly done by the trustee in reference to the property of the bankrupt will now remain valid. A partnership may be adjudged bankrupt, and the general rule of distribution is that the joint creditors have priority of payment out of the joint or partnership property, and the separate creditors out of the separate estate.

A less public form of bankruptcy is also sanctioned by the Act of 1869. By § 125 it is provided that the creditors of a debtor may declare (by a majority in number and three-fourths in value) that his affairs are to be liquidated by arrangement and not in bankruptcy. By § 126 the creditors may, by a resolution under the same conditions, resolve that a composition shall be accepted in satisfaction of the debts due to them by the debtor. If liquidation is resolved on, every creditor, whether having notice of the meeting or not, is absolutely restrained from taking any proceedings for recovering his debt, unless it appears to the court that his debt is judicially affected by the resolution; otherwise under liquidation or composition, the court may restrain or permit other legal processes on respect of provable debts as it thinks fit.

In Scotland, as in England, the law of bankruptcy arose as a remedy against the frauds of insolvent debtors. It was declared by an Act of the Scottish Parliament (1621, c. 18) that no debtor after insolvency should fraudulently diminish the fund belonging to his creditors, and if a deed of assignment was gratuitously executed after the contracting of debt in favour of a near relation or a confidential friend, fraudulent dealing was to be presumed. The Act 1696, c. 5, settled the definition of a notour or notorious bankrupt, a question which had previously engaged the attention of the judges of the Court of Session. The statute defines a "notour bankrupt" to be any debtor who, being under diligence by horning or caption, at the instance of his creditors, shall be either imprisoned, or retire to the abbey or any other privileged place, or flee or abscond for his personal security, or defend his person by force, and who shall afterwards be found, by sentence of the Lords of Session, to be insolvent. Bankruptcy as thus defined was, it is said, intended to afford a remedy against fraudulent preferences by debtors, and not as the ground-work of a general process of distribution, although by later statutes it became a necessary requisite of every such process. The exceptions recognized in the Act of 1696, of persons absent from Scotland, and therefore not liable to imprisonment, or of persons exempted therefrom by special privileges,

were removed by later legislation. The English distinction between traders and non-traders, it will be observed, is not recognized in Scotch law. The statute made null and void all voluntary dispositions, assignments, and other deeds at or after or within sixty days before bankruptcy. The principal Bankruptcy Act now in force is the 19 and 20 Vict. c. 79 (amended by 20 and 21 Vict. c. 19, and 23 and 24 Vict. c. 33).

By section 9 of the principal Act, notour bankruptcy is now constituted—

1. By sequestration (or adjudication in England and Ireland); and

2. By insolvency concurring either—(a), with a duly executed charge for payment followed by imprisonment or apprehension, or flight or retreat to sanctuary, by execution of arrestment of debtor's effects, not discharged within fifteen days, by execution of poinding of any of his movables, or by decree of adjudication of any part of his movable estate; or (b), with sale of effects belonging to the debtor under a poinding or under a sequestration for rent, or retiring for twenty-four hours to the sanctuary, or making application for the benefit of *cessio bonorum*.

Notour bankruptcy continues, in case of sequestration, until the debtor has obtained his discharge, and in other cases until insolvency ceases. Sequestration may be awarded of the estate of any person in the following cases:—

1. Living debtor subject to jurisdiction of Scotch courts,—(a), on his own petition with concurrence of qualified creditors; or (b), on petition of qualified creditors, provided he be a notour bankrupt, and have had a dwelling-house or place of business in Scotland within the previous year.

2. In the case of a deceased debtor, subject at his death to the jurisdiction of the court,—(a), on the petition of his mandatory; or (b), on the petition of qualified creditors (§ 13).

Sequestration may be awarded either by the Court of Session or by the sheriff. A sequestration may be recalled by a majority in number and four-fifths in value of the creditors, who may prefer to wind up the estate by private arrangement. If the sequestration proceeds, the creditors hold a meeting, and by a majority *in value* elect a trustee to administer the estate, and three commissioners (being creditors or their mandatories) to assist and control the administration and declare the dividend. The bankrupt (under pain of imprisonment) must give all the information in his power regarding his estate, and he must be publicly examined on oath before the sheriff; and “conjunct and confident persons” may likewise be examined. The bankrupt may be discharged either by composition or without composition. In the latter case (1) by petition with concurrence of all the creditors, or (2) after six months with concurrence of a majority and four-fifths in value of the creditors, or (3) after eighteen months with concurrence of a bare majority in number and value, or (4) after two years without concurrence. In the last case the judge may refuse the application if he thinks the bankrupt has fraudulently concealed his effects, or wilfully failed to comply with the law.

The procedure in *cessio bonorum* is regulated by 6 and 7 Will. IV. c. 56 (which gave jurisdiction to sheriffs) and Act of Sederunt of June 1839. A debtor who is or has been in prison, or has had a warrant of imprisonment served against him, may present a petition setting forth his inability to pay his debts, and his willingness to surrender his estate, and praying for interim protection. The debtor is examined by the sheriff on oath, and the creditors may be heard against the petition. A decree of *cessio bonorum* operates as an assignation of a debtor's movables to a trustee for behoof of creditors. The bankrupt under a *cessio* has no power to insist on his discharge, and there-

fore cannot protect his subsequent acquisitions against his creditors. By the late statute a majority of the creditors (subject to review by the court) may, in certain cases, resolve that the bankrupt shall be entitled to apply for a decree of *cessio* only, and not to a discharge in the sequestration, and the court may grant the *cessio* in the sequestration without requiring a new process.

By the Bankruptcy (Ireland) Amendment Act, 1872 (35 and 36 Vict. c. 58), the law of Ireland has been assimilated to the new system established by the English Bankruptcy Act 1869. (x. 2.)

#### *Bankruptcy in the United States.*

In the United States, Congress alone has power to pass a bankrupt law which shall have authority throughout the country. The several States may enact such statutes when there is no law of Congress in operation; but these statutes will fully bind only the citizens of the State which enacts it. There is no power to obtain effectual control of property without its limits so as to prevent local preferences; nor can the State laws discharge contracts due to non-residents. The general Government has made so little use of the power confided to it, that many of the States were obliged to pass bankrupt laws, notwithstanding the imperfection of their operation in some cases, and those, often, the most important in the interests involved. Massachusetts had an excellent system, established in 1838, which is specially mentioned because the Act of Congress is largely drawn from this source. All State laws on the subject are suspended while a general law of bankruptcy is in force.

The first general Bankrupt Act was passed in 1800, and repealed in 1803. In 1841 another law was put in operation, with a special view of meeting the urgent needs of debtors who had been ruined by the commercial revulsion of 1837-38, and who could receive no effectual relief from local laws. This Act was repealed in thirteen months, but in the meantime a very large number of cases had been disposed of, amounting, for example, to 3250 in Massachusetts alone. The law now in operation took effect June 1, 1867. It was framed with much care by a committee of the House of Representatives, of which Mr Jencks, of Rhode Island, was the chairman and chief working member. Its authors hoped that it would form a permanent addition to the commercial jurisprudence of the country.

The administrative machinery is simple. The district courts, which have always had the original jurisdiction of causes in admiralty, revenue, and other national matters, are made courts of bankruptcy. The judge of each district ascertains how many registers are needed for the convenient despatch of causes in his territory, and they are appointed by the chief justice of the United States and the district judge concurrently. The registers have, by law, functions chiefly administrative and ministerial; but they, in fact, hear and decide many judicial questions by consent of the parties, and subject to the revision of the judge. In proceedings in bankruptcy proper, such as adjudications, discharges, proof of debts, marshalling assets, there is an appeal from the district to the circuit court, and no farther. Actions at law, or suits in equity, to which assignees in bankruptcy are parties, may be brought either in the State or the Federal courts. If in the latter, the whole case if in equity, or the law points in an action at law, may be carried to the Supreme Court at Washington when the amount in dispute exceeds \$5000, or questions of law, which the judges of the circuit court consider doubtful, may be certified by them to the Supreme Court, whatever may be the amount involved; and all decisions of the highest court of a State, involving questions of law under the Bankrupt Act, may be reviewed by the Supreme Court, if adverse to

the right or title set up under that statute. In some of these various modes the principal questions arising under the Act will in time be settled by the highest judicial authority, and thus uniformity of decision will be secured.

The statute covers the whole ground of bankruptcy and insolvency. It is applied to all debtors, whether traders or not, and to debtors petitioning for its benefits, as well as to those proceeded against by creditors. Any one who owes \$300 may petition, and any such debtor who has committed certain specified acts may be adjudged bankrupt *in invitum*. The acts of bankruptcy are substantially alike in all such statutes in England and the United States, and tend to prove either fraudulent conduct or hopeless insolvency, such as concealing property, conveying it fraudulently, departing the district with intent to defraud creditors, lying in prison for twenty-one days. There is nothing analogous to the trader debtor summons, though the Act of 1800, and the Massachusetts law of 1838, admitted a somewhat similar test of bankruptcy. This law, however, has adopted one which to a considerable extent supplies this want, by declaring a merchant, trader, banker, broker, manufacturer, or miner to be bankrupt who has suffered his commercial paper to remain overdue and unpaid for forty days. No other distinction is made between traders and other debtors, excepting that merchants and tradesmen are bound, under pain of being denied their discharge, to keep proper books of account.

The property of the bankrupt is assigned by the judge or register to the persons chosen by the majority in number and value of the creditors—the court having full power to overrule the choice of the creditors, or to add an assignee to those chosen. The assignment is conclusive evidence of the assignees' authority, and cannot be collaterally impeached on any ground, excepting want of jurisdiction in the bankrupt court, nor in any suit whatever. This most valuable rule was adopted by Massachusetts in 1838, and has saved an enormous amount of useless litigation. There is no danger of injustice from it, because the adjudication against a bankrupt is never made without notice to him, nor without a trial by jury, if he demands one; and any person having an interest adverse to the adjudication has a right to be heard as well as the debtor.

The doctrine of the relation of the assignee's title to an act of bankruptcy committed in the country has not obtained in the United States. That title relates, as in other suits, to the beginning of the proceedings,—that is to say, the day and hour that the petition, whether voluntary or involuntary, is filed. The most marked difference between the English and American statutes, or rather between the practical working of them, is in the extension given by the latter to the doctrine of preference. By the law of 1867 and its amendments, the assignee can avoid all advantages given to pre-existing creditors within four months (in involuntary cases, within two months) before the filing of the petition, if the bankrupt was then insolvent, and intended a preference, and the preferred creditor knew the insolvency and the intent, no matter what pressure, by suit, threat, or otherwise, may have been brought to bear upon the debtor. This law, as construed, operates almost like a relation back of the assignee's title, so far as pre-existing creditors are concerned, unless the payments or settlements have been made in the ordinary course of business, and sometimes, though rarely, when they have been so made. This rule is a logical development of the law of preference, as established in Lord Mansfield's time, and still continued in England. When it is considered that a preference is a technical fraud, and may be charged as an act of bankruptcy and as a valid objection to the debtor's discharge, it will be readily seen that the conduct of debtors in failing circumstances must be much restrained and regulated, to the

advantage of the general creditors, by the perils that attend a partial or unfair mode of settlement, or even a struggle to continue business after recuperation has become hopeless. Such was found to be the operation of a similar law in Massachusetts, where it prevailed for more than twenty years before the statute of that State was suspended by the general Bankruptcy Act of 1867.

The discharge of the debtor is granted or refused by the court absolutely. There are no grades or classes of certificates, and no power to suspend action upon the question, and put the debtor on probation. In voluntary bankruptcies 30 per cent. must be paid in dividends, or the consent of one-fourth in number and one-third in value of the creditors must be obtained. Any creditor may oppose the decree of discharge for fraud committed or continued within six months before the petition, for loss by gaming, and in the case of merchants and tradesmen, as we have seen, for failure to keep suitable accounts. The discharge when granted, is, like the assignment, unimpeachable in any court; but it may be reviewed within two years by the court that granted it, upon evidence afterwards discovered.

The title, powers, and duties of the assignee, the mode of settling joint and separate estates, and marshalling debts and assets, are substantially similar under the English and American systems. The title of the assignee, however, does not depend at all, in any case, upon the date of the petitioning creditor's debt. The misdemeanours created by the law were taken, with some modifications, from the felonies of the English Act in force in 1867. The mode of compounding with creditors has recently been adopted from the English statute of 1869, and has been largely used with good results.

Whether or not the bankrupt law will take its place as part of the settled policy of the country cannot be easily predicted. It is not likely to be displaced until the existing commercial depression has been relieved. After that time much will depend upon the degree of care and economy with which it is administered, and the readiness of Congress to adopt modifications that shall be found to be necessary, but most upon the opinion that the debtors of the country may entertain of its operation. The law was considerably modified in 1874 in the interest of debtors, by making adjudications *in invitum* more difficult, and discharges more easy; but the law is still popular with creditors, because of the serious check it imposes upon local preferences. It is likewise approved by those lawyers and judges who have had the most to do with its administration; and it is not improbable that the effect of a few years more of its operation may be to render it indispensable to the commercial world. (J. L.)

BANKS, SIR JOSEPH, for upwards of forty years president of the Royal Society of London, was born in Argyle Street, London, on the 13th of February 1743. He was the only son of William Banks, a gentleman of considerable landed property, whose father had derived his fortune principally from successful practice as a physician in Lincolnshire, had been on one occasion sheriff of that county, and had for some years represented Peterborough in parliament. Very little is known of Joseph's early life and education. He appears to have been sent at the age of nine to Harrow, and after spending four years there, was removed to Eton. Here he seems first to have acquired a taste for botanical pursuits, and was accustomed to spend all his leisure hours in the beautiful lanes and fields round the school. He carried the same fondness for natural history to Oxford, where he was entered as a gentleman commoner of Christ's College; and by his exertions a lecturer on natural science was for the first time brought into the university. After taking an honorary degree he left Oxford; and at the age of twenty-one he found himself possessed of ample means,

his father having died in 1761. Three years later he made his first scientific expedition to Newfoundland and Labrador, and brought back a rich collection of plants and insects. Shortly after his return, Government resolved to send out Captain Cook to observe the transit of Venus in the Pacific Ocean, and Banks, through the influence of his friend Lord Sandwich, obtained leave to join the expedition. He made the most careful preparations, in order to be able to profit by every opportunity, and induced Dr Solander, a distinguished pupil of Linnæus, to accompany him. He even engaged draughtsmen and painters to delineate such objects of interest as did not admit of being transported or preserved. The voyage occupied three years, and many hardships had to be undergone; but the rich harvest of discovery—many natural phenomena being for the first time brought to light—was more than adequate compensation. Banks was equally anxious to join Cook's second expedition, and expended large sums in engaging assistants and furnishing the necessary equipment; but, owing to ill-feeling on the part of some Government officials, he was compelled to relinquish his purpose. He, however, employed the assistants and materials he had collected in a voyage to Iceland, returning by the Hebrides and Staffa, the geological formation of which he was the first to describe. In 1778 Banks was elected president of the Royal Society, of which he had been a fellow from 1766. His predecessor had been compelled to resign owing to some disagreement with the court, but Banks was always a favourite with the king. In 1781 he was made a baronet; in 1795 he received the Order of the Bath; and in 1797 he was admitted to the Privy Council. During the long tenure of his office as president, Sir Joseph did much to raise the state of science in Britain, and was at the same time most assiduous and successful in cultivating friendly relations with scientific men of all nations. His kindness and liberality were beyond praise, and he was most generous in affording to other naturalists the free use of his vast materials. It has, however, been made matter of objection to him, that from his own predilections he was inclined to overlook and depreciate the labours of the mathematical and physical sections of the Royal Society. Sir Joseph died on the 19th March 1820, at the age of 77. He bequeathed his valuable collections of books and botanical specimens to the British Museum. His only writings are two small tracts of little importance; he seems to have given up his intention of writing an elaborate treatise after the death of his friend and fellow-labourer, Dr Solander. His fame rests mainly on his numerous discoveries in botany and natural history. See Cuvier, *Éloge Historique de N. Banks*, 1821.

**BÁNKURÁ**, a district of British India, within the Bardwán division, under the Lieutenant-Governor of Bengal, situated in 22° and 23° N. lat., and 86° and 87° E. long., bounded on the N. and E. by Bardwán district; on the S. by Midnapur district; and on the W. by Mánbhúm district. Bántúra forms a connecting link between the delta of the Ganges on the E. and the mountainous highlands of Chhotá Nágpur on the W. Along its eastern boundary adjoining Bardwán district the country is flat and alluvial, presenting the appearance of the ordinary paddy lands of Bengal. Going N. and W., however, the surface gradually rises into long undulating tracts; rice lands and swamps give way to a region of low thorny jungle or forest trees; the hamlets become smaller and more scattered, and nearly disappear altogether in the wild forests along the western boundary. The principal hills are—Mánjíá hill, on the south bank of the Dámodar; Koro hill, S. of the foregoing; Susuníá hill, W. of Koro; and Behárináth hill, in the N.W. corner of the district. The rivers are merely mountain torrents—the largest, the Dámodar, being only navigable by country

boats during the rains. The census of 1872 returned the population of the district at 526,772 souls, inhabiting 2028 villages, and 104,687 houses; average density of population, 391 to the square mile. The Hindus numbered 487,786, or 92·6 per cent. of the total population; Mahometans, 13,500; Christians, 70; and persons of unspecified religion, chiefly aboriginal tribes, 25,416.

District area, after recent transfers to and from the districts of Bardwán and Mánbhúm in 1872, 1346 square miles. Before these transfers the area was returned at 1880 square miles, of which 650 were said to be cultivated, 540 cultivable but not cultivated, and 180 uncultivable waste. Agricultural products—rice, barley, cotton, indigo, oil-seeds, and pulses. Minerals—coal, lime, and building stone. In its manufactures, the district is noted for fine descriptions of coloured silk cloths. Exports—rice, oil-seeds, lac, tamarind, silk cloth, silk cocoons, &c. Imports—English piece goods, salt, tobacco, spices, cocoa-nuts, turmeric, and different kinds of pulses. Chief trading towns and seats of commerce—Bántúra, Bishnupur, Rájgrám, and Barjora. Three main lines of road traverse the district. The total revenue increased from £10,934 in 1835-36 to £66,892 in 1870-71, and the civil expenditure from £8006 to £17,487 within the same period. Bántúra is a permanently settled district. In 1870-71 the district contained 910 estates, held by 1351 proprietors, and paying a total Government land revenue of £35,862. Besides the land revenue, the following are returned as the other sources of revenue in 1870-71, viz., assessed taxes, £5455; excise, £3167; stamps, £6787; law and justice, £30,478; law charges, £62; and local and provincial funds, £2512. The police force in 1871 numbered 5681 men, maintained at a cost of £28,656. The district contained 515 schools in 1871-72, attended by 14,676 pupils; maintained at a total cost of £4602, of which Government paid £1291. The climate of Bántúra is generally healthy, the cold season being bracing, the air wholesome and dry, and fogs of rare occurrence. The temperature in the hot season is very oppressive and relaxing. Rainfall in 1868, 61·25 inches; minimum temperature in the same year, 62°; maximum, 98°. The prevailing diseases in the district are intermittent fever, leprosy, and occasionally diarrhoea and dysentery. Cholera visited the district in an epidemic form in the years 1855, 1860, 1864, 1866-67, and 1869, that of the first year being the severest. Bántúra suffered greatly from the famine of 1865-66. Two towns contain a population of upwards of 5000—1. Bántúra, the administrative headquarters; population, 16,794; municipal income in 1872, £551; expenditure, £476. 2. Bishnupur—population, 18,047; municipal income, £273; expenditure, £192. The Bishnupur Ráj was one of the largest estates in Bengal in the end of the last century, but it was sold for arrears of revenue shortly after the conclusion of the permanent settlement in 1793.

**BÁNKURÁ**, the principal town of the district of the same name, in 23° 14' N. lat., and 87° 6' 45" E. long., stands on an elevation on the left bank of the River Dhalkisor. It has a bazar, a spacious building for the accommodation of travellers, and the district courts, school, jail, post-office, &c. In 1872 the population amounted to 16,794.

**BANN**, a considerable river of Ireland, which rises in the Mourne Mountains, County Down, and falls into Longf. Neagh. From this it emerges as the Lower Bann, and, flowing between the counties of Antrim and Londonderry, falls into the Atlantic, four miles S.W. of Portrush. The Upper Bann is navigable for vessels of 50 tons to its junction with the Newry canal, a little above Portadown. The Lower Bann flows in a northerly direction; it is navigable up Coleraine for vessels of 200 tons, but the bar at its mouth renders it difficult of access in rough weather, and its course is broken by a fall of 13 feet about a mile above Coleraine. The salmon and eel fisheries are of considerable value. Measured in a direct line, the Upper Bann is about 35 miles long, and the Lower 30 miles.

**BANNERETS**. In the early ages of chivalry there were two kinds of knights, called respectively *Bachelors* and *Bannerets*. The former carried pennons terminating in a point or points; the latter, banners,—that is to say, pennons rendered square by having the points cut off. This process of converting the pennon into the banner was done by the sovereign himself on the field of battle, standing beneath his own royal standard displayed. The distinction awarded for peculiar gallantry, was a very high one; and those who

enjoyed is ranked above all other knights except those of the Garter. The banner bore the coat armour of the banneret himself, and served as an ensign for the followers and retainers whom he took with him into the camp or court. The king himself and the greatest nobles were members of the order; and we have in the Roll of Caerlaverock the blazon of nearly one hundred bannerets (including the king, eleven earls, and the bishop of Durham) who were present with Edward I. in his campaign against Scotland in 1300. The etymology of the word is clear; and Selden, after expressing his opinion that *baro* is equivalent to *vir*, remarks that "the Germans have also the name of *banner-heer* or *panner-heer*, as if you would say *dominus scutifer*, or the like, or as the title of banneret" (*Titles of Honour*, part i. l. 52). Nevertheless the term banneret, either from simple misapprehension or in order to mark the relative rank of the knight, has been translated *baronetus* (quasi *baro minor*) in some old statutes; and the historian Walsingham, in describing the prisoners at the battle of Stirling, speaks of *Barones et Baronetti viginti duo*, &c. Indeed, in a patent granted to Sir Ralph Vane so late as 4 Edward VI., his grade of banneret is Latinized by *Baronetus*. In France, it is said, the dignity was hereditary; but in England it died with the person who gained it. On the institution of baronets by King James I., the order dwindled, and at length became extinct. The last banneret created was Sir John Smith, who received the dignity after the battle of Edgehill, for his gallantry in rescuing the standard of Charles I.

**BANNOCKBURN**, a village of Scotland, on the Bannock, an affluent of the Forth, three miles S. of Stirling. In 1871 its population amounted to 2564, principally employed in the manufacture of tweeds and carpets. In the neighbourhood, on the 24th of June 1314, was fought the memorable battle which secured the independence of Scotland, and established Bruce upon the throne. A fragment of the "bore stone" in which the royal standard was placed, is still to be seen, protected by an iron framework. At Sauchieburn, in the neighbourhood. James III. was defeated by his subjects in 1488. See SCOTLAND.

**BÁNSWÁRÁ** (literally the forest country), a Rájput feudatory state under the Mewár agency in Rájputána, extends from 23° 10' to 23° 48' N. lat., and from 74° 2' to 74° 41' E. long. It borders on Gujarát, and is bounded on the N. by the native states of Dungarpur and Udaipur or Mewár; on the N.E. and E. by Pratabgarh; on the S. by the dominions of Holkar and the state of Jabuá; and on the W. by the state of Riwalkánta. Bánswára State is about 45 miles in length from N. to S., and 33 miles in breadth from E. to W., and has an area of 1440 square miles, with an estimated population of 144,000 souls. The Mahi is the only river in the state, and great scarcity of water occurs in the dry season. The Maháráwal, as the chief is called, has, however, undertaken the digging of wells, tanks, &c., to meet this want. The Bánswára chief belongs to the family of Udaipur. During the vigour of the Delhi empire Bánswára formed one of its dependencies; on its decline the state passed under the Marhattás. Wearied out by their oppressions, its chief in 1812 petitioned for English protection, on the condition of his state becoming tributary on the expulsion of the Marhattás. The treaty of 1818 gave effect to this arrangement; England guaranteeing the prince against external enemies and refractory chiefs; he, on his part, pledging himself to be guided by her representative in the administration of his state. There are 33 tributary chiefs or Thákurs of this state, and the whole strength of force kept up in 1870-71 was 617 men. Indian corn, wheat, pulses, rice, and other kinds of millet form the chief products of Bánswára. The revenue of the state amounted to £17,595 in 1870-71, exclusive of £3301 set apart for

the personal expenditure of the chief and his family. The total expenditure in the same year amounted to £18,745. An annual tribute of £3997, or 50,000 Salmaháhi rupees, is paid by the chief to the British Government. The custom of *sati*, or widow-burning, has long been abolished in the state, but the people retain all their superstitious notions regarding witches and sorcery; and as late as 1870, a Bhil woman, about 80 years old, was swung to death at Kusalgarh in Bánswára, on an accusation of witchcraft. The perpetrators of the crime were sentenced to five years rigorous imprisonment, but they had the sympathy of the people on their side. The chief town is Bánswára, lat. 23° 30' and long. 74° 24', situated about 8 miles W. of the Mahi river, surrounded by an old disused rampart, and adorned by various Hindu temples, with the battlements of the chief's palace overlooking it.

**BANTAM**, a decayed town of Java, formerly capital of a district of the same name, at the north-western extremity of the island, situated on the Bay of Bantam, near the mouth of a river which falls into the bay. It was once a large, rich, and flourishing city, but is now mostly in ruins. It is about 61 miles W. of Batavia, and is situated on a low, swampy beach, surrounded by jungle, and intersected by stagnant streams, so that its climate is even more unhealthy than that of Batavia was in the last century. Prior to the Dutch conquest Bantam was a powerful Mahometan state, whose sovereign extended his conquests in the neighbouring islands of Borneo and Sumatra. In 1595 the Dutch, under Houtmann, expelled the Portuguese, and formed their first settlement. An English factory was established in 1603, and continued to exist till the massacre of the agents in 1677. In 1683 the Dutch reduced the sultan to vassalage, built the fort of Spialwyk, and monopolized the port, which had previously been free to all comers; and for more than a century afterwards Bantam was one of the most important seats of commerce in the East Indies. In 1811 after Batavia had surrendered to the British, Bantam soon followed; but it was restored to the Dutch in 1814. Two years later, however, they removed their chief settlement to the more elevated station of Serang, or Ceram, seven miles inland, and in 1817 the ruin of Bantam was hastened by an extensive conflagration. The Bay of Bantam was formerly a commodious retreat for vessels; but it is now so choked up with daily accessions of soil washed down from the mountains, as well as by coral shoals extending a considerable way to the eastward, that it is inaccessible to vessels of any considerable burden. Long. 106° 3' E., lat. 6° 4' S.

**BANTRY**, a small seaport situated on Bantry Bay, on the S.W. coast of Ireland, in the county of Cork. Lat. 51° 39' N., long. 9° 24' W. The trade of this port, formerly considerable, is now almost confined to the exportation of grain. The pilchard fishery was once very productive, but the fish has now deserted the coast. The population, which in 1831 was 4276, had decreased in 1871 to 2441 (including 409 in the island of Whiddy). The bay of the same name is about 25 miles long by 4 to 6 broad, has from 10 to 30 or 40 fathoms of water, and is surrounded by high mountains. It affords a very fine harbour for shipping, and contains two small islands, Bear and Whiddy. In 1796 a French fleet anchored here with the view of invading Ireland, and landed eight men, who were immediately taken prisoners.

**BANU**, a district of British India, under the Lieutenant-Governor of the Panjáb, lies between 33° 15' 30" and 32° 10' 30" N. lat., and 72° 1' and 70° 27' E. long. It is bounded on the N. by the Khatábi hills, separating it from the district of Kohát, and by a corner of the Rawál Fíndi district; on the E. by the districts of Jhilam and Sháhpur; on the S. by the district of Derá Ismáil Khán; and on the

W. by the Waziri hills. Total area, 3148 square miles. Population, 287,547: consisting of Hindus, 26,222, or 9.12 per cent.; Mahometans, 260,550, or 90.61 per cent.; Sikhs, 493; others, 282; density of population per square mile, 91. The principal tribes inhabiting the district are—(1.) Waziri Patháns, recent immigrants from the hills, for the most part peaceable, and good cultivators; (2.) Banuchis, inhabitants of Banu proper; (3.) Patháns, criminal and depraved, with all the vices and few of the virtues of their race, but fair cultivators; and (4.) Muráti Patháns, inhabitants of the Erákkel valley, a fine manly race, truthful and industrious.

The Indus flows through the district from north to south, dividing it into two portions. The other streams are the Kúram (which falls into the Indus) and its tributary the Gambilá. The course of the Indus is very capricious, and has a tendency to encroach eastwards. During inundations its vast body of waters stretches for many miles across the country. Principal crops of Banu district: wheat, barley, grain, and pulses for the spring harvest; millet, Indian corn, sugarcane, cotton, and oil seeds, for the autumn harvest. Average produce of land per acre in lb.:—Rice, 369 lb.; cotton, 100; sugar 1394; tobacco, 512; wheat, 480; other inferior grains, 640; oil-seeds, 240; fibres, 87. Cultivated area of the district in 1871-72, 450,519 acres; uncultivated and pasture grounds, 414,607; cultivable, 58,562; uncultivable, 1,092,498; total, 1,665,622 acres, or 2446 square miles reported on. Revenue from all sources in 1871-72, £50,218, of which £42,741 was derived from the land. The first regular settlement of the land revenue commenced in 1871-72, and is still (1874) in progress. A police force of 404 men of all grades is maintained, of whom 395 belong to the imperial, 87 to the municipal, and 12 to the primitive police. The district contained 33 schools in 1871-72, attended by 1152 pupils. The principal towns are—Trákkhel, population, 7446; Káiláugh, 6119; Edwardesálad (Banu), 8188; Bhangí-khel, 5339; Nínal, 501; and Yán Bachrán, 6178.

**BANYAN TREE** (*Ficus indica*, Linn., *Urostigma benghalense*, Gaertn.) is a native of several parts of the East Indies and Ceylon. It has a woody stem, branching to a great height and vast extent, with heart-shaped entire leaves terminating in acute points. Every branch from the main body throws out its own roots, at first in small tender fibres, several yards from the ground; but these continually grow thicker until they reach the surface, when they strike in, increase to large trunks, and become parent trees, shooting out new branches from the top, which again in time suspend their roots, and these, swelling into trunks, produce other branches, the growth continuing as long as the earth contributes her sustenance. On the banks of the Nerbudda, according to Forbes's *Oriental Memories*, stands a celebrated tree of this kind, which is supposed to be that described by Neirelus the admiral of Alexander the Great. This tree once covered an area so immense, that it has been known to shelter no fewer than 7000 men. Though now much reduced in size by the destructive power of the floods, the remainder is still nearly 2000 feet in circumference, and the trunks large and small exceed 3000 in number.

**BAPHOMET**, the imaginary symbol or idol which the Knights Templars were accused of worshipping in their secret rites. The term is supposed to be a corruption of *Mahomet*, who in several mediæval Latin poems seems to be called by this name. Von Hammer wrote a dissertation in the *Mémoires de l'Orient*, 1818, in which he revived the old charge against the Templars. The word, according to his interpretation, signifies the baptism of *Metis*, or of fire, and is, therefore, connected with the impure rites of the lowest Gnostic sects, the Ophites. Additional evidence of this, according to Von Hammer, is to be found in the architectural decorations of the Templars' churches. An elaborate and, so far as has yet appeared, successful criticism of Von Hammer's arguments, was made in the *Journal des Savans*, March and April 1819, by M. Raynouard, well known as the defender of the Templars. See also Hallam, *Middle Ages*, c. i. note 15.

**BAPTISM**, Christian baptism is the sacrament by

which a person is admitted into the Christian Church. The word is derived from the Greek βαπτίζω, the frequentative form of βάπτω, to dip or wash, which is the term used in the New Testament when the sacrament is described. In discussing what is meant by baptism, three things have to be inquired into—(1) the origin of the rite; (2) its meaning, or the doctrine of baptism, and (3) the form of the rite itself.

1. *The Origin of Baptism*.—Christian theologians do not require to go further back than to the New Testament, for there, in the record of our Lord's life, and in the writings of His apostles, they find all that is required to form a basis for their doctrines. The principal passages in the New Testament in which baptism is described are as follows:—Matt. xxviii. 18-20; Mark xvi. 16; John iii. 26; Acts ii. 38, x. 44, *f.*, viii. 16, xix. 1, *f.*, xxii. 16; Rom. vi. 4; 1 Cor. i. 14-16, vi. 11; Eph. v. 26; Col. ii. 12; Heb. x. 22, 23, &c. From these texts we learn that baptism is specially connected with the gift of the Holy Spirit, with the forgiveness of sins, with our being buried with Christ; and we are also taught by whom baptism is to be administered, and who are the proper partakers in the ordinance. It is from a due arrangement and comparison of the conceptions in these texts that a doctrine of baptism has been formed. But while theologians do not require to go beyond the New Testament for the origin and meaning of baptism, historical investigation cannot help trying to trace analogies to the rite in Old Testament and even in Pagan history. In the New Testament itself there are two distinct kinds of baptism spoken of—the baptism of John and Christian baptism. Treatises on Jewish antiquities speak of the baptism of proselytes; and St Paul applies the term baptism to describe certain Old Testament events, and we find in use among certain Pagan tribes rites strongly resembling Christian baptism, so far as external ceremonies go. Hence the question arises, What is the relation of Christian baptism to these?

Writers on the antiquities of the Christian church were accustomed to find the source of Christian baptism in the baptism of John, and to assert that John's baptism was simply a universal and symbolical use of the well known ceremony of the baptism of proselytes, and they connected this Jewish rite with Old Testament and even with Pagan lustrations. But this mode of explanation must now be abandoned. It is very difficult to show any real connection between the baptism of John and Christian baptism further than the general relation which all the actions of the forerunner must have had to those of the Messiah. We know very little about the baptism of John, and all attempts to describe it minutely are founded either upon conjecture or upon its identity with the baptism of proselytes. Was John's baptism an initiation, and if so, initiation into what? Did Christ baptize in His lifetime, or did Christian baptism properly begin after Christ's death, and after the mission of the Holy Ghost? What was the formula of John's baptism, and was there any change or growth in the formula of Christian baptism? (The Tübingen School, for example, think that the formula in Acts ii. is much earlier than the complete and more developed one in Matt. xxviii. 19.) All these questions require to be answered with much more precision than the present state of our information admits of, before we can define the precise relation subsisting between the baptism of John and the baptism of Christ.

The connection between the baptism of John and the Jewish baptism of proselytes, of which a great deal has been made, is also founded on assumptions which cannot be proved. This very plausible theory first assumes that proselytes were baptized from an early time in the Jewish Church, although the Old Testament tells us nothing about



it, and then supposes that John simply made use of this ordinary Jewish rite for the purpose of declaring symbolically that the whole Jewish nation were disfranchised, and had to be re-admitted into the spiritual Israel by means of the same ceremony which gave entrance to members of heathen nations. But the subject of the baptism of proselytes is one of the most hopelessly obscure in the whole round of Jewish antiquities, and can never be safely assumed in any argument; and the general results of investigation seem to prove that the baptism of proselytes was not one of the Jewish ceremonies until long after the coming of Christ, while there is much to suggest that this Jewish rite owes its origin to Christian baptism. Others again, as Steitz, find the historical basis of baptism in the lustrations or sprinklings with water so often mentioned in the Old Testament, in such symbolical acts as Naaman's bathing in the Jordan, and in various prophecies where purification from sin is denoted by sprinkling, e.g., Ezek. xxxvi. 25-30, Zech. xiii. 1, &c.; but such anticipations can scarcely be called the historical origin of the rite. Many modern writers connect baptism with certain Pagan rites, and point to the lustrations in use in religious initiation among the Egyptians, Persians, and especially the Hindus, but very little can be made of such far-fetched analogies. Perhaps the most curious instances of this kind is to be found in the double baptism,—the one Pagan and civil, and the other religious and Christian,—which existed side by side with each other in Norway and Iceland. The Pagan rite was called "ansa vatni," while the name for Christian baptism was "akéro." The Pagan rite was much older than the introduction of Christianity, and was connected with the savage custom of exposing infants who were not to be brought up. The newly-born infant was presented to the father, who was to decide whether the child was to be reared or not; if he decided to rear it, then water was poured over the child and the father gave it a name; if it was to be exposed, then the ceremony was not gone through. The point to be observed is that, if the child was exposed by any one after the ceremony had been gone through, it was a case of murder, whereas it was not thought a crime if the child was made away with before water had been poured over it and it had been named. The analogy lies in the use of water, the bestowal of the name, and the entrance into civil life through the rite.

II. *The Doctrine of Baptism.*—Among the Greek Fathers, for it is there we must look for the beginning of the doctrine, baptism was called by various names, all of which referred to the spiritual effects which were supposed to accompany the rite. For example, a common term for baptism was *Παλιγγενεσία*, or *regeneration*—for every Christian was supposed to be born again by the waters of baptism. "We fishes," says Tertullian, "are born in water, conformable to the name of our Lord Jesus Christ,—*ἰχθύς*." (*Ἰησοῦς Χριστός, Θεοῦ Υἱός, Σωτήρ = ἰχθύς*.) It was also called *φωτισμός*, or *illumination*; *μυστήριον*; *signaculum*, or seal of the Lord; *character Dominicus*; *μύησις* or *μυσταγωγία*, the initiation; *εφοδίον*, or viaticum, from its being administered to departing persons; *sacerdotium laici*, or the lay priesthood, because allowed, in cases of necessity, to be conferred by laymen; the *great circumcision*, because it was held to succeed in the room of circumcision; *δῶρον* and *χάρισμα κυρίου*, the *gift of the Lord*, because it had Christ for its author, and not man; sometimes by way of eminence simply *δῶρον*; *τελείωσις* and *τελετή*, the *consecration* and *consecration*, because it gave men the perfection of Christians, and a right to partake of τὸ τελεῖον, the Lord's Supper. In studying the statements made by the early Fathers upon baptism, we find not so much a distinct and definite doctrine as gropings toward a doctrine, and it is not until we come to St Augustine that we can find any

strict and scientific theory of the nature and effects of the sacrament. The earlier theologians sometimes make statements which imply the most extreme view of the magical effects of the sacrament, and at other times explain its results in a purely ethical way. Thus, for example, Hermas says,—“Our life is sanctified by water;” while Tertullian expressly declares,—“Anima non lavatione sed responsione sancitur.” It should never be forgotten that the abundant use of metaphorical language by the Greek Fathers, and the want of anything like a strictly theological terminology, prevent our finding anything like the precise doctrinal statements which became familiar in the Western Church; while the prevalence of curious Greek physical speculations, which taught the creative power of water, mingled with and distorted the ideas about the effects of the water in baptism. It was St Augustine, the great theologian of the Western Church, who first gave expression to exact dogmatic statements about the nature and meaning of baptism. The real difficulty to be explained was the connection between the outward rite and the inward spiritual change; or to put it more precisely, the relation between the water used and the Holy Spirit who can alone regenerate. The Greek theologians had shirked rather than faced the difficulty, and used terms at one time exaggerating the magical value of the element, at another insisting on the purely ethical and spiritual nature of the rite; but they never attempted to show in what precise relation the external rite stood to the inward change of heart. It is true that one or two theologians had almost anticipated Augustine's view, but the anticipation was more apparent than real, for the theology of the Greek Church in this, as in most other doctrines, is greatly hampered by the mystical tendency to represent regeneration and kindred doctrines much more as a species of chemical change of nature than as a change in the relations of the will. Augustine insisted strongly on the distinction between the sacrament itself and what he called the “*res sacramenti*,” between the inward and spiritual and the outward and material, and by doing so Augustine became the founder of both the modern Roman Catholic and the modern orthodox Protestant views. Apart from certain modifying influences, it would not be difficult for the orthodox Protestant to subscribe to most of Augustine's views upon baptism, for he insists strongly on the uselessness of the external sign without the inward blessing of the Spirit. But in this doctrine, as in most others, Augustine's doctrine of the Church so interfered as to make practically inoperative his more spiritual views of baptism. The Church, Augustine thought, was the body of Christ, and that in a peculiarly external and physical way, and just as the soul of man cannot, so far as we know, exert any influence save upon and through the body, so the Spirit of Christ dispenses His gracious and regenerating influences only through the body of Christ, i.e., the Church. But the Church, Augustine thought, was no invisible spiritual communion. It was the visible kingdom of God, the visible “*civitas Dei* in peregrinatione per terras,” and so entrance into the Church, and the right and possibility of participating in the spiritual benefits which members of the Church can alone enjoy was only possible by means of a visible entrance into this visible kingdom. Thus while Augustine in theory always laid greatest stress upon the work of the Holy Spirit and upon the spiritual side of baptism, he practically gave the impulse to that view of the sacrament which made the external rite of primary importance. It was the Holy Spirit who alone imparted spiritual gifts to the children of God. But the one way by which the benefits of this Spirit could be shared was in the first place through baptism. Baptism was thought to be necessary to salvation, and all who were unbaptized were unsaved. In this way Augustine, while

recognizing the spiritual nature of the sacrament, held views about the importance of the rite which were as strong as those of any Greek theologian who had mingled confusedly in his mind Christian doctrines and the maxims of Pagan philosophy about the creative power of the element of water. Of course such a doctrine of the importance of the baptism with water had to be modified to some extent. There were cases of Christian martyrs who had never been baptized, and yet had confessed Christ and died to confess Him: for their sakes the idea of a baptism of blood was brought forward—they were baptized not with water, but in their own blood. And the same desire to widen the circle of the baptized led the way to the recognition of the baptism of heretics, laymen, and nurses. It was the Augustinian doctrine of baptism which was developed by the Schoolmen, and which now is the substance of modern Roman Catholic teaching. The Schoolmen, whose whole theology was dominated by the Augustinian conception of the Church, simply took over and made somewhat more mechanical and less spiritual Augustine's doctrine. They were enabled to give the doctrine a more precise and definite shape by accommodating it to the terms of the Aristotelian philosophy. They began by distinguishing between the matter and the form of baptism. Had Augustine had this distinction before him he would probably have called the water the matter, and the action of the Holy Spirit the form which verified and gave shape to the matter; but the whole idea of the Schoolmen was much more mechanical, the magical idea of the sacrament came much more into prominence, and the spiritual and ethical fell much more into the background, and with them, while water was the *materia sacramenti*, the *forma sacramenti* was the words of the rite,—“I baptize thee,” &c., &c. Thus insensibly the distinction between the external rite and the work of the Holy Spirit, which Augustine had clearly before him in theory at least, was driven back into its original obscurity, and while it was always held theoretically that the grace conferred in baptism was conferred by the Holy Spirit, still the action of the Spirit was so inseparably connected with the mechanical performance of the rite, that the external ceremony was held to be full warrant for the inward spiritual presence and power, and it was held that in baptism grace was conferred *ex opere operato*. The actual benefits which were supposed to come in this way were, freedom from original sin and forgiveness of it and all actual sins committed up to the time of baptism, and the implanting of the new spiritual life—a life which could only be slain by a deadly sin. The Scholastic doctrine of baptism is the doctrine of the Roman Catholic Church, and the restatements made by Möhler on the one hand, and Jesuit theologians on the other, do not do more than give a poetical colouring to the doctrine, or bring out more thoroughly the magical and mechanical nature of the rite.

The Protestant doctrine of baptism, like the Scholastic or Roman Catholic, is to be traced back to Augustine and his distinction between the sign and the thing signified, and may be looked at as a legitimate development of the Augustinian doctrine, just as that must be considered to be an advance on the doctrine of the early Church Fathers. The early Fathers had confused the sign with the thing signified,—the water with the action of the Holy Spirit,—and could only mark their half-conscious recognition of the distinction by an alternating series of strong statements made now on the one side and now on the other. Augustine distinguished the two with great clearness, but connected them in an *external* way by means of his conception of the visible Church and of baptism as the door leading into it, and this led his followers to pay exclusive attention to the external side, until the thing signified

became lost in the sign. The Protestant theologians connected the two in an *internal* way by means of the spiritual conception of faith, and so were able always to keep the sign in due subordination to the thing signified. It is *faith*—not faith in the sense of imperfect knowledge, or assent to intellectual propositions, but faith in the sense of personal trust in a personal Saviour, or “*fiducia*,” as the 17th century theologians called it—<sup>1</sup> which so connects the water with the presence and power of the Spirit that the one is the means which the other uses to impart His spiritual grace. In this way baptism is looked upon as one of the means of grace, and grace is imparted through it as through the other means—the Lord's Supper, the Word of God, prayer, &c. Just as the dead letters and sounds of the Word of God are but the signs of the presence and power of His Spirit, and become at His touch the living revelation of the Lord, so in baptism, the outward rite, worthless in itself, becomes the sign and pledge of the presence and power of the Spirit of God; and as, in the case of the Word of God, it is faith or “*fiducia*” that on the human side connects the external signs with the inward power of the Spirit, so, in baptism, it is the same faith which unites the water and the Spirit. So far all orthodox Protestants are agreed, but in order to show the historical evolution of the doctrine, it is necessary to notice in a sentence the difference between the Lutheran and the Calvinist doctrines. Luther's own doctrine of baptism changed very much: in the second stage—the stage represented by the tract, *De Babyl. Capt. Eccl.*—it is not different, in germ at least, from the Calvinist view; but he afterwards drew back and adopted views much nearer to the Scholastic theory. He was evidently afraid that, if he went too far from the Scholastic doctrine, and insisted too strongly on the importance of faith, he might be led on to reject the baptism of infants; and his later theories are a recoil from that. The question which Luther had to face and answer here was, What is meant by faith, the faith which connects the symbol with the reality, and so appropriates the gifts of God's grace in the sacrament? Is it a faith which begins and ends in the individual act of faith at work in the person that is baptized? or is it a much wider thing with a more universal significance? Luther did not face this question thoroughly, but his recoil from the Reformed theory of baptism seems to show that he would have taken the former answer. Nor did Calvin face the question; but his doctrine of baptism implies that he would have taken the latter answer. The faith which a man has in Christ, the faith which appropriates, is not the individual's only, but extends far beyond him and his small circle. It is awakened by the Holy Spirit, it comes into being within the sphere of God's saving purpose. Its very existence indicates a *solidaritas* between the individual believer and the whole Church of God. Hence on the Reformed doctrine, while faith is essential to the right appropriation of the blessing in the rite, there is no need for thoroughly developed faith in those who are baptized. If they are infants, then they are baptized because of the faith of their parents or near relations, or of the congregation before whom the baptism is performed; only those who are the sponsors for the child bind themselves before God to train up the child to know that it has been baptized, and to appropriate in conscious individual faith the benefits of the ordinance. Such is the Reformed theory of baptism; and it rests upon the ideas of the *solidaritas* of believers, of the prior existence of the Church to the individual believers, and of the ethical unity of the Church. On the other hand, those who hold that the Church is simply the sum of individual men and women, and that it is increased not by the silent widening of the influence of God's saving purpose within mankind, but by individual conversions and by individuals joining the

Church, cannot help regarding infant baptism as a mere mockery. Hence the doctrines of the Anabaptists, Baptists, Mennonites, &c. (see BAPTISTS), who reject infant baptism altogether, and maintain that there can be no valid baptism without the conscious appropriation by an act of faith of the benefits symbolized by the rite. It is to be noticed that the tendency of those who reject infant baptism is to regard the sacrament not so much as a means of grace, but simply as an act symbolical of entrance into the Church, and to approach in this way the views of the Socinians and Remonstrants. Quakers reject baptism altogether along with the sacrament of the Supper.

III. *Baptismal Rites*.—In the Apostolic and immediately post-Apostolic Church, there was no stated time or place for baptism. Philip baptized the Ethiopian eunuch by the roadside, as soon as he had declared his faith. Afterwards, however, Easter, Whitsuntide, and Epiphany were seasons supposed to be specially appropriate for baptism, and the sacrament was not performed at other times save in cases of necessity. Baptism, Tertullian said, had special reference to the death and rising again of our Lord, and also to the mission of the Holy Ghost; and festivals which were connected with these events were specially appropriate for baptism. As soon, too, as churches were built, and congregations formed, baptism became a public act of worship, and was generally performed in baptisteries built adjoining the church. The early Church, like most of the Reformation Churches condemned private baptism.

In the Apostolic Church the baptismal rite seems to have been a very simple one. "Repent and be baptized, every one of you," was all that Peter thought it necessary to say to those whom he invited to join the Christian Church; but soon after the Apostolic times baptism became a very elaborate ceremonial. No one could be baptized unless he had submitted to a long and elaborate course of instruction as a catechumen; and in order to be made a catechumen a ceremony of some length had to be gone through. The candidate was received into the number of the catechumens by the laying on of hands and prayer; and, in the Western Church, salt was given to him, the *salis datio* being held to be the special *sacramentum catechumenorum*. Catechumens were permitted to attend public worship at first as hearers only; afterwards they were permitted to take part in the responses and genuflections of the audience. From these catechumens the candidates for baptism, called *competentes* or *electi*, were from time to time selected. The baptismal ceremony was a lengthy one. The catechumens were first received, then got their Christian names, then, facing the west, the place of darkness, they renounced the devil and all his works. The priest then exorcised them, by laying his hands upon their heads and breathing into their faces. After the exorcism came the opening of the ears and nose, a ceremony which had special reference to the descent of the Holy Ghost upon Christ in the form of a dove. The catechumens were then anointed with the catechumen oil. (This part of the ceremony was sometimes gone through after baptism, although it is possible that there were two anointings, one before and one after.) The officiating priest then repeated the Creed and the Lord's Prayer, and gave a short explanation of their meaning, and the lengthy ceremony was concluded by the catechumen repeating the Lord's Prayer and the Apostles' Creed. All these ceremonies preceded the special baptismal rite, and commonly occupied more than one day. In the baptismal ceremony the minister first consecrated the water by prayer, and the catechumen was then baptized in the name of the Father, the Son, and the Holy Ghost. The usual mode of performing the ceremony was by immersion. In the case of sick persons (*dicina*) the minister was allowed to baptize by pouring water upon the head or by sprinkling. In the

early Church "clinical" baptism, as it was called, was only permitted in cases of necessity, but the practice of baptism by sprinkling gradually came in in spite of the opposition of councils and hostile decrees. The Council of Ravenna, in 1311, was the first council of the Church which legalized baptism by sprinkling, by leaving it to the choice of the officiating minister. The custom was to immerse three times, once at the name of each of the persons in the Trinity, but latterly the threefold immersion was abolished, because it was thought to go against the unity of the Trinity. The words used in baptizing always embodied the formula in the last chapter of St Matthew. But the mode of uttering them varied. In the Western Church the priest uttered the simple formula, but in the Eastern Church the common formula was, βαπτίζωμαι ὁ δοῦλος τοῦ θεοῦ ὁ δέωμαι εἰς τὸ ὄνομα τοῦ πατρὸς—'Αμὴν—καὶ τοῦ υἱοῦ—'Αμὴν—καὶ τοῦ ἁγίου πνεύματος—'Αμὴν—ὦν καὶ δεῖ εἰς τοὺς αἰῶνας τῶν αἰώνων. 'Αμὴν. After immersion the neophyte partook of milk and honey to show that he was now the recipient of the gifts of God's grace; he was then anointed with oil to show that he was enrolled among the spiritual priesthood, and with the unction was joined the sign of the cross made on the forehead. Then followed the laying on of hands, which latterly, when the episcopate became separate from the presbytery, was done by the bishop, and was the germ of the sacrament of confirmation. In the course of time one or two other symbolical actions were added; the neophyte was clothed in a white garment—(hence Pentecost, which was the principal baptismal festival, was called Whit Sunday)—and a band (chrismale) was put round his head. In the Eastern Church there followed the girding of the loins of the neophyte and the crowning of him with a consecrated corona, significant of his entrance into the royal priesthood; in the Western Church a burning cross was given him. In the various Eastern churches the rites differed somewhat from each other, nor was exact uniformity to be found in the Western Church. It could easily be shown that a great deal of this complex ceremonial took its origin from the introduction of Pagan ceremonies into the Christian worship.

The present form of administering baptism in the Church of Rome is as follows:—When a child is to be baptized, the persons who bring it wait at the door of the church for the priest, who comes thither in his surplice and his purple stole surrounded by his clerks. He begins by questioning the godfathers, whether they promise in the child's name to live and die in the true Catholic and Apostolic faith; and what name they would give to the child. Then follows an exhortation to the sponsors, after which the priest, calling the child by its name, asks, "What dost thou demand of the Church?" The godfather answers, "Eternal life." The priest proceeds, "If thou art desirous of obtaining eternal life, keep God's commandments,—Thou shalt love the Lord thy God," &c.; after which he breathes three times in the child's face, saying, "Come out of this child, thou evil spirit, and make room for the Holy Ghost." Then he makes the sign of the cross on the child's forehead and breast, saying, "Receive the sign of the cross on thy forehead and in thy heart;" upon which, taking off his cap, he repeats a short prayer, and, laying his hand gently on the child's head, repeats a second prayer; then he blesses some salt, and putting a little of it into the child's mouth, he says, "Receive the salt of wisdom." All this is performed at the church door. Afterwards, the priest, with the godfathers and godmothers, come into the church, and advancing towards the font, repeat the Apostles' Creed and the Lord's Prayer. Arrived at the font, the priest again exorcises the evil spirit, and taking a little of his own spittle, with the thumb of his right hand rubs it on the child's ears and nostrils, repeating as he touches the right

eat, the same word *Ἐφφάθη*, "be thou opened," which our Saviour made use of to the man born deaf and dumb. Lastly, they pull off its swaddling-clothes, or strip it below the shoulders, during which the priest prepares the oil. The sponsors then hold the child directly over the font, observing to turn it due east and west; whereupon the priest asks the child whether he renounces the devil and all his works, and the godfather having answered in the affirmative, the priest anoints the child between the shoulders in the form of a cross; then taking some of the consecrated water, he pours part of it thrice on the child's head, at each perfusion calling on one of the persons of the Holy Trinity. The priest concludes the ceremony of baptism with an exhortation. It may be added that the Roman Church allows midwives, in cases of danger, to baptize a child before the birth is completed. A still-born child thus baptized may be buried in consecrated ground.

With regard to the form of baptism used in the Church of England, we shall only mention one or two of the more material differences between the form as it stood in the first liturgy of King Edward, and that in the English Common Prayer Book at present. First, the form of consecrating the water did not make a part of the office in King Edward's liturgy, as it does in the present, because the water in the font was changed and consecrated but once a month. The form itself likewise was something different from that now used, and was introduced with a short prayer that Jesus Christ, upon whom (when He was baptized) the Holy Ghost came down in the likeness of a dove, would send down the same Holy Spirit, to sanctify the fountain of baptism, which prayer was afterwards left out at the second revision. By King Edward's first book the minister was required to dip the child in the water thrice; first the right side, secondly the left, and lastly the face toward the foot. This triple immersion was a very ancient practice in the Christian Church, and was used in honour of the Holy Trinity,—though some later writers say it was done to represent the death, burial, and resurrection of Christ, together with His three days' continuance in the grave. But afterwards, the Arius persuading the people that the custom denoted a distinct substantiality of the three persons in the Trinity, the orthodox party discontinued it and used only one single immersion.

By the first Common Prayer Book of King Edward, after the child was baptized the godfathers and godmothers were to lay their hands upon him, and the minister was to put on him the white vestment, commonly called the *chrysome*, and to say, "Take this white vesture as a token of the innocency which, by God's grace, in this holy sacrament of baptism, is given unto thee, and for a sign whereby thou art admonished, so long as thou livest, to give thyself to innocence of living, that after this transitory life thou mayest be partaker of the life everlasting." As soon as he had pronounced these words, he was to anoint the infant on the head, saying, "Almighty God, the father of our Lord Jesus Christ, who hath regenerated thee by water and the Holy Ghost, and hath given unto thee remission of all thy sins, may He vouchsafe to anoint thee with the unction of His Holy Spirit, and bring thee to the inheritance of everlasting life."

*Baptism of the dead* seems to have been founded on the opinion that when men had neglected to receive baptism in their lifetime, some compensation might be made for this default by their receiving it after death, or by another being baptized for them. This practice was chiefly in use among various heretical sects.

*Hypothetical Baptism* was that administered in certain doubtful cases, with the formula, "If thou art baptized, I

do not rebaptize; if thou art not, I baptize thee in the name of the Father," &c.

*Solemn Baptism* was that conferred at stated seasons. Such in the ancient Church were the Paschal baptism and that at Whitsuntide. This is sometimes also called general baptism.

*Lay Baptism* we need not have been permitted both by the Common Prayer Book of King Edward, and by that of Queen Elizabeth, when an infant is in immediate danger of death, and a lawful minister cannot be had; but afterwards, in a convocation held in the year 1575, it was unanimously resolved, that even private baptism, in a case of necessity, was only to be administered by a lawful minister. The Scotch Reformed Church also prohibited private baptism by lay persons, but ordained that when any had been thus baptized, the rite was not to be repeated.

The name *baptism* has been applied to certain ceremonies used in giving names to things inanimate. The ancients knew nothing of the custom of giving baptism to inanimate things, such as bells, ships, and the like. The first notice we have of this is in the capitulars of Charles the Great, where it is mentioned with censuro; but afterwards it crept by degrees into the Roman offices. Baronius carries its antiquity no higher than the year 968, when the great bell of the church of Lateran was christened by Pope John III. At last it grew to such a height as to form a ground of complaint in the *Centum Gravamina* of the German nation, drawn up at the diet of Nuremberg in 1581, where the ceremony of baptizing a bell, with godfathers, &c., to make it capable of driving away tempests and devils, was declared to be a superstitious practice, contrary to the Christian religion, and a mere seduction of the simple people.

Authorities:—Bingham's *Origines Ecclesiasticæ*, lib. 10, 11; Grimm's *Deutsche Rechtalterthümer*; J. G. Walch, *Historia Pædagogicæ baptismi quatuor priorum seculorum*; G. T. Vossius, *Disput. Viginis de Baptismo*. (T. M. L.)

**BAPTISTERY** (*Baptisterium*, in the Greek Church *φωτιστήριον*) was a hall or chapel in which the catechumens were instructed and the sacrament of baptism administered. It was commonly a circular building, although sometimes it had eight and sometimes twelve sides, and consisted of an ante-room (*προαύλιος οίκος*) where the catechumens were instructed, and where before baptism they made their confession of faith, and an inner apartment where the sacrament was administered. In the inner apartment the principal object was the baptismal font (*κολυμβήθρα*, or *piscina*), in which those to be baptized were immersed thrice. Three steps led down to the floor of the font, and over it was suspended a golden or silver dove; while on the walls were commonly pictures of the scenes in the life of the Baptist. The font was at first always of stone, but latterly metals were often used. Baptisteries belong to a period of the church when great numbers of adult catechumens were baptized, and when immersion was the rule. We find little or no trace of them before Constantine made Christianity the state religion, &c., before the 4th century; and as early as the 6th century the baptismal font was built in the porch of the church and then in the church itself. After the 9th century few baptisteries were built, the most noteworthy of later date being those at Pisa, Florence, Padua, Lucca, and Parma. Some of the older baptisteries were very large, so large that we hear of councils and synods being held in them. It was necessary to make them large, because in the early church it was customary for the bishop to baptize all the catechumens in his diocese (and so baptisteries are commonly found attached to the cathedral and not to the parish churches), and also because the rite was performed only thrice in the year. (See BAPTISM.) During the months when there were no

baptisms the baptistery doors were sealed with the bishop's seal. Baptisteries, we find from the records of early councils, were first built and used to correct the evils arising from the practice of private baptism. As soon as Christianity made such progress that infant baptism became the rule, and as soon as immersion gave place to sprinkling, the ancient baptisteries were no longer necessary. They are still in general use, however, in Florence and Pisa. The name *baptistery* is sometimes also given to a kind of chapel in a large church, which served the same purpose. (*Cf. Hefele's Concilien, passim*; Du Cange, *Glossary*, article "Baptisterium"; Eusebius, *Hist. Eccl.* x. 4; Bingham's *Antiquities of the Christian Church*, book xi.)

**BAPTISTS**, a denomination of Christians, distinguished, as their name imports, from other denominations by the views they hold respecting the ordinance of baptism.

The early history of the Baptists, both in this country and on the Continent, is very obscure. In the great awakening of religious thought and feeling which characterized the beginning of the 16th century, it was inevitable that amongst those who burst the fetters which bound them to the see of Rome some should be willing to retain as much of the ancient doctrine and practice as they could with a safe conscience, whilst others, rejoicing in their new-found liberty, would desire to cast aside every remnant of what they regarded as superstition, and to advance as far as possible in the path of what they deemed Christian liberty; nor is it at all to be wondered at that strange and wild theories on matters even remotely connected with religion should spring into life. But amidst all the diversities of opinion that existed, it was constantly held by Protestants that "holy Scripture containeth all things necessary to salvation, so that whatsoever is neither read therein nor may be proved thereby, although it be sometime received of the faithful as godly and profitable for an order and comeliness, yet no man ought to be constrained to believe it as an article of faith or repute it requisite to the necessity of salvation" (Articles of King Edward VI.) We must not be surprised that the right of private judgment, which is involved in the principle thus broadly laid down, was nevertheless far from being conceded to the extent that was desired by those who departed farthest from the Church of Rome. In fact, each separate section of Protestants claimed for itself to stand on the ground of holy Scripture, and was prepared to resist alike the tyranny of Rome and what it considered the licence of other bodies of Protestants. Thus it happened that the Baptists, or as their opponents called them, the Anabaptists (or, as Zwingli names them, Catabaptists), were strenuously opposed by all other sections of the Christian Church, and it was regarded by almost all the early reformers to be the duty of the civil magistrate to punish them with fine and imprisonment, and even with death. There was, no doubt, some justification for this severity in the fact that the fanaticism which burst forth in the early times of the Reformation frequently led to insurrection and revolt, and in particular that the leader of the "peasant war" in Saxony, Thomas Münser, and probably many of his followers, were "Anabaptists." One result of this severity is, that the records of the early history of the Anabaptists both on the Continent and in this country are very few and meagre. Almost all that is currently known of them comes to us from their opponents. There is, however, much valuable information, together with detailed accounts of their sufferings, in the Dutch Martyrology of Van Bracht, himself a Baptist, which bears the title *Martelaers Spiegel der Doops-gesinde* (2d ed. fol., 1685), an English translation of the latter half of which was published in 2 vols. 8vo, Lond. 1850-53, edited by Dr Underhill, now secretary of the Baptist Missionary Society. Probably

the earliest confession of faith of any Baptist community is that given by Zwingli in the second part of his *Elencus contra Catabaptistas*, published in 1527. Zwingli professes to give it entire, translating it, as he says, *ad verbum* into Latin. He upbraids his opponents with not having published these articles, but declares that there is scarcely any one of them that has not a written (*descriptum*) copy of these laws which have been so well concealed. The articles are in all seven. The first, which we give in full, relates to baptism:—

"Baptism ought to be given to all who have been taught repentance and change of life, and who in truth believe that through Christ their sins are blotted out (*abolita*), and the sins of all who are willing (*volens*) to walk in the resurrection of Jesus Christ, and who are willing to be buried with him into death, that they may rise again with him. To all, therefore, who in this manner seek baptism, and of themselves ask us, we will give it. By this rule are excluded all baptisms of infants, the great abomination of the Roman pontiff. For this article we have the testimony and strength of Scripture, we have also the practice of the apostles; which things we simply and also stedfastly will observe, for we are assured of them."

The second article relates to withdrawal (*abstentio*) or excommunication, and declares that all who have given themselves to the Lord and have been baptized into the one body of Christ should, if they lapse or fall into sin, be excommunicated. The third article relates to the breaking of bread; in this it is declared that they who break the one bread in commemoration of the broken body of Christ, and drink of the one cup in commemoration of His blood poured out, must first be united together into the one body of Christ, that is, into the church of God. The fourth article asserts the duty of separation from the world and its abominations, amongst which are included all papistical and semi-papistical works. The fifth relates to pastors of the church. They assert that the pastor should be some one of the flock who has a good report from those who are without. "His office is to read, admonish, teach, learn, exhort, correct, or excommunicate in the church, and to preside well over all the brethren and sisters both in prayer and in the breaking of bread; and in all things that relate to the body of Christ, to watch that it may be established and increased so that the name of God may by us be glorified and praised, and that the mouth of blasphemers may be stopped." The sixth article relates to the power of the sword. "The sword," they say, "is the ordinance of God outside the perfection of Christ, by which the bad is punished and slain and the good is defended." They further declare that a Christian ought not to decide or give sentence in secular matters, and that he ought not to exercise the office of magistrate. The seventh article relates to oaths, which they declare are forbidden by Christ.

However much we may differ from the points maintained in these articles, we cannot but be astonished at the vehemence with which they were opposed, and the epithets of abuse which were heaped upon the unfortunate sect that maintained them. Zwingli, through whom they come down to us, and who gives them, as he says, that the world may see that they are "fanatical, stolid, audacious, impious," can scarcely be acquitted of unfairness in joining together two of them,—the fourth and fifth,—thus making the article treat "of the avoiding of abominable pastors in the church" (*Super devotions abominabilium pastorum in Ecclesia*), though there is nothing about pastors in the fourth article, and nothing about abominations in the fifth, and though in a marginal note he himself explains that the first two copies that were sent him read as he does, but the other copies make two articles, as in fact they evidently are. To us at the present day it appears not merely strange but shocking, that the Protestant Council of Zürich, which had scarcely won its own liberty, and was still in dread of the persecution of the Romanists, should pass a decree

ordering, as Zwingli himself reports, that any person who administered anabaptism should be drowned; and still more shocking that, at the time when Zwingli wrote, this cruel decree should have been carried into effect against one of the leaders of the Anabaptists, Felix Mantz, who had himself been associated with Zwingli, not only as a student, but also at the commencement of the work of Reformation. No doubt the wild fanaticism of some of the opponents of infant baptism seemed to the Reformers to justify their severity. In 1537 Menno Simonis joined himself to the Anabaptists and became their leader. His moderation and piety, according to Moheim, held in check the turbulence of the more fanatical amongst them. He died in 1561, after a life passed amidst continual dangers and conflicts. His name remains as the designation of the Mennonites, who eventually settled in the Netherlands under the protection of William the Silent, Prince of Orange.

Of the introduction of Baptist views into England we have no certain knowledge. Fox relates that "the registers of London make mention of certain Dutchmen counted for Anabaptists, of whom ten were put to death in sundry places in the realm, *anno* 1535; other ten repented and were saved." In 1536 King Henry VIII, as "in earth supreme head of the Church of England," issued a proclamation together with articles concerning faith agreed upon by Convocation, in which the clergy are told to instruct the people that they ought to repute and take "the Anabaptists' opinions for detestable heresies and to be utterly condemned." The document is given in *extenso* by Fuller, who further tells us from Stow's *Chronicles* that, in the year 1538, "four Anabaptists," three men and one woman, all Dutch, bare faggots at Paul's Cross, and three days after a man and woman of their sect was burnt in Smithfield." In the reign of Edward VI., after the return of the exiles from Zürich, Hooper writes to his friend Bullinger in 1549, that he reads "a public lecture twice in the day to so numerous an audience that the church cannot contain them," and adds, "the Anabaptists flock (*confluunt*) to the place and give me much trouble." It would seem that at this time they were united together in communities separate from the Established Church. Latimer, in 1552, speaks of them as segregating themselves from the company of other men. In Philpott's sixth examination in 1555 we are told that Lord Riche said to him, "All heretics do boast of the Spirit of God, and every one would have a church by himself, as Joan of Kent and the Anabaptists." Philpott was imprisoned soon after Mary's accession in 1553; and it is very pleasing to find, amidst the records of intense bitterness and rancour which characterized these times, and with which Romanist and Protestant alike assailed the persecuted Baptists, a letter of Philpott's, to a friend of his, "prisoner the same time in Newgate," who held Baptist opinions. His friend had written to ask his judgment concerning the baptism of infants. Philpott in a long reply, whilst maintaining the obligation of infant baptism, yet addresses his correspondent as, "dear brother, saint, and fellow-prisoner for the truth of Christ's gospel," and at the close of his argument he says, "I beseech thee, dear brother in the gospel, follow the steps of the faith of the glorious martyrs in the primitive church, and of such as at this day follow the same." During the whole of the 16th century, and through the greater part of the 17th, whatever changes took place in the state church, the Baptists in England, together with other dissenters, continued to suffer persecution. Archbishop Sandys, about the year 1576, says: "It is the property of froward sectaries," amongst whom he classes Anabaptists, "whose inventions cannot abide the light, to make obscure conventicles;" and though he admits that "when the gospel is

persecuted, secret congregations are allowed," he declares that as the gospel, "strengthened with the civil hand," is now publicly and sincerely preached, "such stray sheep as will not of their own accord assemble themselves to serve the Lord in the midst of this holy congregation, may lawfully and in reason ought to be constrained thereunto." There is no doubt that a large number of the Baptists in England at this time came from Holland, but there is little reason to think that Fuller is correct when, after speaking of certain Dutch Anabaptists being seized in 1575, some of whom were banished and two burnt at Smithfield, he adds, "we are glad that English as yet were free from that infection."

About the beginning of the 17th century the severe laws against the Puritans led many dissenters to emigrate to Holland. Some of these were Baptists, and an English Baptist Church was formed in Amsterdam about the year 1609. In 1611 this church published "a declaration of faith of English people remaining at Amsterdam in Holland." The article relating to baptism is as follows:—"That every church is to receive in all their members by baptism upon the confession of their faith and sins, wrought by the preaching of the gospel according to the primitive institution and practice. And therefore churches constituted after any other manner, or of any other persons, are not according to Christ's testament. That baptism or washing with water is the outward manifestation of dying unto sin and walking in newness of life; and therefore in no wise appertaineth to infants." They hold "that no church ought to challenge any prerogative over any other;" "that magistracy is a holy ordinance of God;" "that it is lawful in a just cause for the deciding of strife to take an oath by the name of the Lord."

The last execution for heresy in England by burning alive took place at Lichfield, April 11, 1612. The condemned person, Edward Wightman, was a Baptist. Much uncertainty rests on the history of the Baptists during the next twenty years. It would seem that many members of the Brownist or Independent denomination held Baptist views. An independent congregation in London, gathered in the year 1616, included several such persons, and as the church was larger than could conveniently meet together in times of persecution, they agreed to allow these persons to constitute a distinct church, which was formed on the 12th September 1633; and upon this most, if not all, the members of the new church were baptized. Another Baptist church was formed in London in 1639. These churches were "Particular" or Calvinistic Baptists. The church formed in 1609 at Amsterdam held Arminian views. In 1644 a Confession of Faith was published in the names of seven churches in London "commonly (though falsely) called Anabaptist," in which were included the two churches just mentioned. The article on baptism is as follows:—"That baptism is an ordinance of the New Testament given by Christ to be dispensed only upon persons professing faith, or that are disciples, or taught, who, upon a profession of faith, ought to be baptized." "The way and manner of dispensing this ordinance the Scripture holds out to be dipping or plunging the whole body under water." They further declare that "a civil magistracy is an ordinance of God," which they are bound to obey. How well they understood the distinction between the rights of conscience and the rights of the civil magistrate is shown with remarkable clearness.—

"We believe," they say, "that in all those civil laws which have been acted by them [the supreme magistracy], or for the present are or shall be ordained, we are bound to yield subjection and obedience unto in the Lord, as conceiving ourselves bound to defend both the persons of those thus chosen, and all civil laws made by them, with our persons, liberties, and estates, with all that is called ours, although we should suffer never so much from them in not actively

submitting to some ecclesiastical laws, which might be conceived by them to be their duties to establish, which we for the present could not see, nor our consciences could submit unto; yet are we bound to yield our persons to their pleasure."

They go on to speak of the breathing time which they have had of late, and their hope that God would, as they say, "incline the magistrates' hearts so far to tender our consciences as that we might be protected by them from wrong, injury, oppression, and molestation;" and then they proceed: "But if God withhold the magistrates' allowance and furtherance herein, yet we must, notwithstanding, proceed together in Christian communion, not daring to give place to suspend our practice, but to walk in obedience to Christ in the profession and holding forth this faith before mentioned, even in the midst of all trials and afflictions, not accounting our goods, lands, wives, children, fathers, mothers, brethren, sisters, yes, and our own lives, dear unto us, so that we may finish our course with joy; remembering always that we ought to obey God rather than men." They end their confession thus: "If any take this that we have said to be heresy, then do we with the apostle freely confess, that after the way which they call heresy worship we the God of our fathers, believing all things which are written in the Law and in the Prophets and Apostles, desiring from our souls to disclaim all heresies and opinions which are not after Christ, and to be steadfast, unmovable, always abounding in the work of the Lord, as knowing our labour shall not be in vain in the Lord." The breathing time of which they speak was not of long continuance. Soon after the Restoration (1660) the meetings of Nonconformists were continually disturbed by the constables, and their preachers were carried before the magistrates and fined or imprisoned. One instance of these persecutions will, perhaps, be more impressive than any general statements. In the records of one of the churches at Bristol still existing, and having, now and for perhaps nearly two centuries, their place of meeting in Broadmead, but at this time meeting in divers places, we find this remark: "On the 29th of November 1685 our pastor, Brother Fownes, died in Gloucester jail, having been kept there for two years and about nine months a prisoner, unjustly and maliciously, for the testimony of Jesus and preaching the gospel. He was a man of great learning, of a sound judgment, an able preacher, having great knowledge in divinity, law, physic, &c.; a bold and patient sufferer for the Lord Jesus and the gospel he preached." From the same records we learn that on the 25th March 1683, whilst Mr Fownes was preaching in the wood where they were accustomed secretly to meet, they were surrounded by horse and foot. Mr Fownes was taken and committed "to Gloucester jail for six months on the Oxford Act." The record adds, "the text Brother Fownes had been preaching from was 2 Tim. ii. 9." There could scarcely have been found a more appropriate text for his last sermon to the congregation,—“Wherein I suffer trouble as an evil doer even unto bonds; but the word of God is not bound.”

With the Revolution of 1688, and the passing of the Act of Toleration in 1689, the history of the persecution of Baptists, as well as of other Protestant dissenters, ends. The removal of the remaining disabilities, such as those imposed by the Test and Corporation Acts repealed in 1828, has no special bearing on Baptists more than on other Nonconformists. The ministers of the "three denominations of dissenters,"—Presbyterians, Independents, and Baptists,—resident in London and the neighbourhood, had the privilege accorded to them of presenting on proper occasions an address to the sovereign in state, a privilege which they still enjoy.

The Baptists were early divided into two sections,—those who in accordance with Arminian views held the doctrine

of "General Redemption," and those who, agreeing with the Calvinistic theory, held the doctrine of "Particular Redemption;" and hence they assumed respectively the names of General Baptists and Particular Baptists. In the last century many of the General Baptists had gradually adopted the Arian, or, perhaps the Socinian theory; whilst, on the other hand, the Calvinism of the Particular Baptists had in many of the churches become more rigid, and approached or actually became Antinomianism. In 1770 the orthodox portion of the General Baptists formed themselves into a separate association, under the name of the General Baptist New Connection, since which time the "Old Connection" has gradually merged into the Unitarian denomination. Somewhat later many of the Particular Baptist churches became more moderate in their Calvinism, a result largely attributable to the writings of Andrew Fuller. Up to this time the great majority of the Baptists admitted none either to membership or communion who were not baptized, the principal exception being the churches in Bedfordshire and Hertfordshire, founded or influenced by Bunyan, who maintained that difference of opinion in respect to water baptism was no bar to communion. At the beginning of the present century this question was the occasion of great and long-continued discussion, in which the celebrated Robert Hall took a principal part. The practice of mixed communion gradually spread in the denomination. Still more recently many Baptist churches have considered it right to admit to full membership persons professing faith in Christ, who do not agree with them respecting the ordinance of baptism. Such churches justify their practice on the ground that they ought to grant to all their fellow Christians the same right of private judgment as they claim for themselves. It may not be out of place here to correct the mistake, which is by no means uncommon, that the terms Particular and General as applied to Baptist congregations are intended to express this difference in their practice, whereas these terms relate, as has been already said, to the difference in their doctrinal views. The difference now under consideration is expressed by the terms "strict" and "open," according as communion (or membership) is or is not confined to persons who, according to their view, are baptized.

The Baptists early felt the necessity of providing an educated ministry for their congregations. Some of their leading pastors had been educated in one or other of the English universities. Others had by their own efforts obtained a large amount of learning, amongst whom Dr John Gill was eminent for his knowledge of Hebrew. He is said to have assisted Bishop Walton in the preparation of his Polyglot. Mr Edward Terrill, from whose *Records* we have already quoted, and who died in 1685, left a considerable part of his estate for the instruction of young men for the ministry, under the superintendance of the pastor of the church now meeting in Broadmead, Bristol, of which he was a member. Other bequests for the same purpose were made, and from the year 1720 the Baptist Academy, as it was then called, received young men as students for the ministry amongst the Baptists. Fifty years later, in 1770, a society, called the Bristol Education Society, was formed to enlarge this academy; and it was still further enlarged by the erection of the present Bristol Baptist College about the year 1811. In the North of England a similar Education Society was formed in 1804 at Bradford, Yorkshire, which has since been removed to Rawdon near Leeds. In the metropolis a college was formed in 1810 at Stepney, and was removed to Regent's Park in 1856. The Pastors' College in connection with the Metropolitan Tabernacle was instituted in 1856. Besides these, the General Baptists have maintained a college since 1797 which at present is carried on at Chil-

well, near Nottingham. A theological institution, intended to promote the views of the "Strict" Baptists, has lately (1866) been established at Manchester. There is also a Baptist theological institution in Scotland, and there are three colleges in Wales. The total number of students in these institutions may be reckoned to be about 200.

The Baptists were the first denomination of British Christians that undertook the work of missions to the heathen, which has become so prominent a feature in the religious activity of the present century. As early as the year 1784, the Northamptonshire Association of Baptist churches resolved to recommend that the first Monday of every month should be set apart for prayer for the spread of the gospel, a practice which has since, as a German writer remarks, extended over all Protestant Christendom, and we may add over all Protestant Missions. Six years later, in 1792, the Baptist Missionary Society was formed at Kettering in Northamptonshire, after a sermon on Isaiah lii. 2, 3, preached by the afterwards celebrated William Carey, the prime mover in the work, in which he urged two points: "Expect great things from God; attempt great things for God." In the course of the following year Carey sailed for India, where he was joined a few years later by Marshman and Ward, and the mission was established at Serampore. The great work of Dr Carey's life was the translation of the Bible into the various languages and dialects of India. The society's operations are now carried on, not only in the East, but in the West Indies, Africa, and Europe. In 1873 there were employed 87 European missionaries and 229 native pastors and evangelists, at 423 stations,—the total number of members of churches being 32,444. The funds of the society amounted to upwards of £40,000, exclusive of the amount raised at mission stations. In 1816 the General Baptists established a missionary society, the operations of which are confined to India. It employs 16 missionaries, male and female, and 16 native preachers, and has an annual income of £14,000.

In regard to church government, the Baptists agree with the Independents that each separate church is complete in itself, and has, therefore, power to choose its own ministers, and to make such regulations as it deems to be most in accordance with the purpose of its existence, that is, the advancement of the religion of Christ. A comparatively small section of the denomination maintain that a "plurality of elders" or pastors is required for the complete organization of every separate church. This is the distinctive peculiarity of those churches in Scotland and the north of England which are known as *Scottish Baptists*. The largest church of this section, consisting at present of 484 members, originated in Edinburgh in 1765, before which date only one Baptist church—that of Keiss in Caithness, formed about 1750—appears to have existed in Scotland. The greater number of the churches are united in associations voluntarily formed, all of them determined by geographical limits except the General Baptist Association, which includes all the churches connected with that body. The associations, as well as the churches not in connection with them, are united together in the Baptist Union of Great Britain and Ireland, formed in 1813. This union, however, exerts no authoritative action over the separate churches. One important part of the work of the union is the collection of information in which all the churches are interested. According to the *Baptist Handbook* for the present year (1875), there are in the United Kingdom—Baptist churches, 2612; places of worship, 3521; pastors, 1916; members, 254,998.

Some of the English settlers in all parts of the world have carried with them the principles and practice of the Baptists. The introduction of Baptist views in America was due to

Roger Williams, who emigrated to Boston, Massachusetts, in 1630. Driven from Massachusetts on account of his denying the power of the civil magistrate in matters of religion, he formed a settlement and founded a state in Rhode Island, and having become a Baptist he formed, in 1639, the first Baptist church in America, of which he was also for a short time the pastor. It is impossible here to trace the history of the Baptists in the United States. In 1873 there are reported—churches, 20,520; ministers, 12,589; members, 1,633,939. The great majority of the churches practise "strict" communion. Their missionary society is large and successful, and perhaps is best known in this country through the life of devoted labour of Dr Judson in Burmah. There are many Baptist churches also throughout British America. In the more recent colonies of Australia and New Zealand a large number of Baptist churches have been formed during the last twenty-five years, and have been principally supplied with ministers from England. (F. W. G.)

BAR, a town of Russian Poland, in the government of Podolia, 50 miles N.E. of Kaminetz. It is situated on the River Rov, an affluent of the Bug, and was formerly called by that name itself. Its present designation was bestowed in memory of Bari in Italy, by Bona Sforza, the consort of Sigismund I. of Poland, who had rebuilt the town after its destruction in 1452 by the Tatars. From 1672 to 1659 it remained in possession of the Turks. In 1678 a conspiracy of the Polish nobles, Pulaski, Krasinski, and others, against the Russians was formed in the town, which was shortly after taken by storm, but did not become finally united to Russia till the partition of 1793. Eleven fairs are held every year, but the trade of the place is not very great. Population, 8077.

BAR-HEBREÛS. See ABULFARAGIUS, vol. i. p. 60.

BAR-LE-DUC, or BAR-SUR-ORNAIN, the chief town of the department of Meuse in France. It occupies the declivity and base of a hill, in lat. 48° 46' 8" N., long. 5° 9' 47" E., on the River Ornain, a tributary of the Marne, 125 miles E. of Paris, and consists of an upper and lower town, the latter being the more modern and respectable of the two. It is a railway station on the Paris-and-Strasbourg line, and the Marne-and-Rhine canal passes in the immediate vicinity. A college, a normal school, a society of agriculture and arts, and a public library, are among its educational institutions. The only building of mark is the church of St Pierre, which contains a curious figure of a half decayed body in white marble, originally forming part of the mausoleum of René of Châlons, Prince of Orange. The castle, which formed the nucleus of the upper town, was built by Frederick I., duke of Lorraine, in the 10th century. Louis XI. got possession of the place and caused it to be fortified in 1474. It was dismantled under Louis XIV. in 1670, but retains a few relics of the ancient works. An extensive traffic is maintained in wood, wine, and wool; and the manufactures of cotton stuffs, hats, hosiery, leather, and confections, are considerable, the last-mentioned article being especially celebrated. Population in 1872, 15,175. The district of Bar was governed by a series of counts from 959 to 1354, when it was raised to a duchy, which in 1419 was ceded to René of Anjou, and henceforward followed the fortunes of Lorraine. The motto of the dukes, which has been adopted by the town, was *Plus penser que dire*. Their coins were usually distinguished by two barbets.

BAR-SUR-AUBE, the chief town of an arrondissement in the department of Aube, in France. It is a station on the Paris-and-Mulhouse line, and is situated on the right bank of the River Aube, at the foot of Sainte-Germaine, in a picturesque district, the wine of which is much esteemed. It is a pretty little town, with a few remains of its ancient



fortifications. There are several churches of considerable antiquity—the most remarkable being Saint Maclou. In 1814 Bar-sur-Aube was the scene of several conflicts between Oudinot and the Allied Army, in which the latter ultimately gained the victory. Population in 1872, 4463. Long. 4° 44' E., lat. 48° 13' N.

BAR-SUR-SEINE, the chief town of an *arrondissement* in the department of the Aube, in France. In the Middle Ages Bar-sur-Seine was a place of considerable importance, and, according to Froissart, contained no fewer than 900 "hôtels" or mansions. It was devastated in 1359 by marauders from Lorraine, and suffered greatly in the religious wars of the 16th and 17th centuries. A battle was fought here in 1814 between the French and the Allies. Long. 4° 24' E., lat. 48° 5' N. Population in 1872, 2798.

BARA BANKI, a district of British India under the jurisdiction of the Chief Commissioner of Oudh, lies between 26° and 28° of N. lat. and 81° and 82° of E. long. It is bounded on the N.W. by the district of Sitápur; on the N. by Bharáich; on the N.E. by Gondá; on the E. by Faizábád; on the S. by Sultánpur and Bai Baréh; and on the W. by Lucknow. The district stretches out in a level plain interspersed with numerous *sháls* or marahas. In the upper part of the district the soil is sandy, while in the lower part it is clayey, and produces finer crops. The principal rivers are the Ghagrá (*Gogra*), forming the northern boundary, and the Gúmtí, flowing through the middle of the district. Both are navigable by country cargo boats. Area, 1735 square miles, of which 1244 are classified as follows:—321 cultivated, 172 culturable but not cultivated, and 251 unculturable waste. Estimated population in 1869, 875,587, or 650 to the square mile, living in 148,166 houses and 2065 villages; Hindus, 748,061; Mahometans, 127,315; Christians, 76. Population in 1872, 1,101,954 souls. Five towns in the district contain over 5000 inhabitants—Nawárganj, 10,496; Rudaulí, 12,517; Fathipur, 7494; Daríábád, 5999; and Rámnagar, 5714. Principal crops, and their acreage:—Rice, 132,459 acres; wheat, 224,583; pulses and other food grains, 304,636; oil-seeds, 23,000; sugar-cane, 29,586; cotton, 509; opium, 3423; indigo, 4875; fibres, 675; tobacco, 6051; and vegetables, 6351 acres. The agricultural stock and beasts of burden in the district consisted in 1871-72 of 83,232 cows and bullocks, 1000 horses, 2590 ponies, 2840 donkeys, 75,913 sheep and goats, 51,060 pigs, 1181 carts, 26,121 ploughs, and 1533 boats. Of the population returned in 1869, 741,989 were agriculturists, and 133,598 non-agriculturists. The means of communication within the district consist of 337 miles of well-made roads, and 78 miles of railway were under construction in 1872. Total revenue in 1871-72, £165,662, of which £157,505, or 95 per cent., was derived from the land. The police consist of (1), a regular constabulary force, 490 strong, maintained at a cost of £6812 per annum; and (2), the village watch, numbering 9558 men; total, 10,043, or about 1 to each 100 of the population, according to the estimate of 1872.

BARAHAT, a town of northern Hindustán, situated in the Himálayas, and within the native state of Garhwal, in 30° 45' N. lat. and 78° 29' E. long. The town was almost destroyed in 1803 by an earthquake—a calamity greatly aggravated by the houses having been built of large stones, with slated roofs. From its central position, it maintains a free communication with all parts of the hills, and those who make the pilgrimage to Gángotri generally halt here and lay in a stock of provisions for the journey. In the neighbourhood stands a curious trident in honour of Siva. The pedestal is of copper, the shaft of brass about 12 feet, and the forks about 6 feet in length. There is no tradition to show the origin of this curious relic; and although it bears a legible inscription, no one has as yet

deciphered it. The temple in which it was formerly enclosed was destroyed by the earthquake of 1803.

BARANTE, AMABLE GUILLAUME PROSPER, Baron de Brugière, an eminent French statesman, and the learned historian of the dukes of Burgundy, was the son of an advocate, and was born at Riom, June 10, 1782. At the age of sixteen he entered the Ecole Polytechnique at Paris, and at twenty obtained his first appointment in the civil service. His abilities secured him rapid promotion, and in 1806 the post of auditor to the council of state was given to him. After being employed in several political missions in Germany, Poland, and Spain, during the next two years, he became prefect of Vienna. At the time of the return of Napoleon I. he held the prefecture of Nantes, and this post he immediately resigned. About this period he married. On the second restoration of the Bourbons he was named councillor of state and Secretary-general of the Ministry of the Interior. About the same time he was elected to the Chamber of Deputies for the two departments of Puy-de-Dôme and Loire Inférieure; but in the following year, in consequence of being under the legal age of a deputy, as required by a new law, he lost his seat. After filling for several years the post of Director-general of Indirect Taxes, he was created, in 1819, a peer of France, and took an active and prominent part as a member of the opposition in the debates of the Upper Chamber. During the same period the leisure hours which he could spare from his political engagements were devoted to literary studies. After the revolution of July 1830, M. de Barante was appointed ambassador to Turin; whence, five years later, he was transferred in the same capacity to St Petersburg. Throughout the reign of Louis Philippe he remained a supporter of the Government; and after the fall of the monarchy in February 1848, he withdrew from political affairs and retired to his country seat in Auvergne. Shortly before his retirement he had been made Grand Cross of the Legion of Honour. As a scholar his *opus magnum* is the *Histoire des Ducs de Bourgogne de la Maison de Valois*, which appeared in a series of volumes between 1824 and 1828. It procured him immediate admission among the Forty of the French Academy; and its great qualities of scholarship, impartiality, accuracy, and purity of style, have given him a place among the greatest French historians. Amongst the other literary works of M. de Barante are a *Tableau de la Littérature Française au dix-huitième Siècle*, of which several editions were published; *Des Communes et de l'Aristocratie* (1821); a French translation of the dramatic works of Schiller; *Questions Constitutionnelles* (1850); *Histoire de la Convention Nationale*, which appeared in six volumes between 1851 and 1853; *Histoire des Directeurs de la République Française* (1855); *Études Historiques et Biographiques* (1857); *La Vie Politique de M. Royer-Collard* (1861). The version of *Hamlet* for M. Guizot's *Shakespeare* was the work of M. de Barante. He spent the last eighteen years of his life in retirement in Auvergne, and died there on November 22, 1866.

BARANYA, a province in the kingdom of Hungary, extending over 1960 square miles. It lies in the angle formed at the junction of the Danube and the Drave, is traversed by offshoots of the Styrian Alps, and contains one city, 13 market-towns, and 341 villages. The inhabitants number about 283,500, and consist of Magyars, Germans, Croatsians, and Servians, a large proportion being Roman Catholics. The greater part of the land is fertile, but a portion of it is marshy and unhealthy. The chief products are corn, wine, flax, tobacco, asparagus, and potash. Warm springs are found at Tapolca, Sikló, and Harkany. There are some valuable quarries of marble and millstones, and numerous coal-mines. The rearing of sheep



streams or streamlets. The gullies or ravines, the result, no doubt, of volcanic agency, are, however, very numerous, radiating from the high semicircular ridge of the coralline formation in a very regular manner to the west, north, and south, but not to the east, where the coral rocks end abruptly. The chalky soil of the district called Scotland (from its assumed resemblance to the scenery of the Highlands) contains *symplocia*, and is altogether different from the deposits of the coral animals which form the superficial area of six-sevenths of the island (91,000 acres). Besides the chalk or marl, sandstone is found in this district. The climate of Barbados is healthy; the temperature equable. For eight months in the year the sea breezes keep it delightfully cool for a tropical country. The extent of cultivation, the absence of swamps (the porous character of the rock immediately underlying the soil preventing accumulations of stagnant water) account for the freedom from miasma. The destruction of the forests may have made the rainfall—upon which successful cultivation depends—somewhat uncertain, but does not seem to have affected it to such an extent as might have been anticipated. The rainfall is caused, apart from elevation, by the exposure of the land to those winds laden with moisture which strike the island at different periods of the year. The average rainfall of the four years 1753–6 was 55·89 inches; of the twenty five-years 1847–71, 57·74 inches; of the single year 1873, 51·28 inches. The sugar production of the island is calculated at 800 hogsheads of 16 cwt. each for every inch of rain.

The N.E. trade-wind blows for three-fourths of the year, and most of the rain comes from the same quarter. March is the driest of the months, and October the wettest; the average rainfall for the former being 1½ inch, and for the latter 9 inches. Leprosy is not uncommon among the negroes, and elephantiasis is so frequent as to be known by the name of “Barbados leg.”

Bridgetown is the capital and port of the island, and the centre of business activity. It contains about 23,000 inhabitants. Over the creek which received the waters from the heights around the Indians had built a rude bridge. This was known for a long time after the British settlement as the Indian Bridge, but as the settlement grew, and after the old bridge had been replaced by a more solid structure, the place received the name of Bridgetown. The town was destroyed by fire in 1666, and rebuilt, principally of stone, upon a larger scale. It suffered again from fire in 1766 and 1845. It has a large town-hall. The Government buildings are a handsome pile close to the sea. The town follows the curve of the bay. Behind it the hills begin to rise, forming the first stepping-stone to the higher lands of the interior. At the southern extremity are the extensive buildings for the garrison, Barbados being the headquarters of the troops in the West Indian command.

Opinions differ as to the derivation of the name of the island. It is probably the Spanish word for the hanging branches of a vine which strike root in the earth. In maps of the 16th century the island appears under various names, among which are *St. Bernardo*, *Bernardos*, *Barbudoso*, *Barudoso*, and *Barudo*. The traces of Indians in this island are more numerous than in any other of the Caribbees. The first recorded visit of Englishmen was in the year 1605, when the crew of the “Olive Blossom” landed, and erected a cross as a memorial of the event, cutting at the same time upon the bark of a tree the words “James, king of England and of this island.” This party of adventurers did not settle, but from the time of their visit the history of Barbados begins. That history has some special features. It shows the process of peaceful colonization, for the island, acquired without conquest or

bloodshedding, has never since been out of the possession of the British. It was the first English colony where the sugar-cane was planted. Its colonists have almost from the beginning enjoyed representative institutions, and the full measure of English freedom. They have always defended their rights with spirit, and shown consistent loyalty to the Crown. The prominence and accessibility of the island have made it important as a military station in the wars with the French and Dutch. And its varying fortunes show the effects of the commercial legislation of England, from the stringent Navigation Laws of Cromwell down to the repeal of the sugar duties in 1874.

The first patent conveying a proprietary interest in Barbados was granted by James I. to Lord Leigh, afterwards earl of Marlborough. In 1624 a ship, belonging to Sir William Courteen, a rich merchant of London, called at Barbados. The country was found to be thickly wooded, and uninhabited, except by a great number of wild hogs. Sir William Courteen, having received a description of the place, sent out two large ships under the authority of Marlborough's patent. One of these, the “John and William,” commanded by John Powell, arrived in February 1625, which is therefore the date of the earliest English settlement in the island. The thirty settlers laid the foundation of a town which they called Jamestown, and chose Captain William Deane their governor. But the earl of Carlisle, having obtained from King James in 1624 the warrant for a grant of all the Caribbean Islands, twenty-two in number, agreed, in 1627, to pay the earl of Marlborough £300 a year for his right to Barbados. The patent in favour of Lord Carlisle passed the great seal on 2d July 1627; but during his absence on a diplomatic mission soon after, William, earl of Pembroke, the Lord Chamberlain, obtained in the interest of Sir William Courteen a grant of several islands, including Barbados. Upon Lord Carlisle's return he obtained the revocation of Lord Pembroke's grant, and the full confirmation of his own rights, upon which he acted in offering to sell parcels of land for an annual payment of 40 lb of cotton. The Society of London Merchants then obtained from Lord Carlisle a grant of 10,000 acres, and they appointed Charles Wolferstone, a native of Bermuda, to proceed with sixty-four persons, and to govern the settlement under a commission from the earl. Wolferstone and his party arrived in July 1628 in the bay, known thenceforth as Carlisle Bay. The antagonism between the earlier settlers under Courteen's auspices and Wolferstone's party broke out into actual fighting. Finding that the validity of his patent was still being disputed, Lord Carlisle obtained a further confirmation of it by the king in April 1629, and at once despatched Sir William Tufton as commander-in-chief with a sufficient force to subdue the rival settlers. In 1645 Philip Bell became governor, and the real progress of the colony began. Good laws were passed, a judicial system was elaborated; the island was divided into eleven parishes, and a general assembly formed by two representatives of each parish, elected by a majority of freeholders. A council had been in existence since the time of Wolferstone.

The first settlers cultivated maize, sweet potatoes, plantains, and yams for their own consumption, and indigo, cotton wool, tobacco, ginger, and aloes for export. Quantities of logwood, fustic, and lignum vitae were also shipped. But the adaptability of the soil for cane becoming known, and the necessary knowledge for the manufacture of sugar being obtained, this article at once became the great staple of the colony. The value of property very largely increased. The half of an estate of 500 acres, 200 under cane, with buildings and appurtenances, was sold for £7000 about the year 1650, the labourers being slaves from Africa.

It was while the rapid progress of the colony was attracting especial attention, and many persons of family and means, adherents of the royal cause, were finding it a refuge from the troubles at home, that Francis Lord Willoughby of Parham went out as governor, with the consent of King Charles II., who had been proclaimed in Barbados as soon as the news of the execution of Charles I. had arrived. Lord Carlisle had died, and his heir had been entrusted with the duty of paying his debts out of the revenue from the island. Lord Willoughby agreed to take a lease from the new earl of the profits of the colony for twenty-one years, to pay Lord Carlisle one-half, and to accept the governorship, including that of the other islands in the Carlisle grant. Upon his arrival in 1650, notwithstanding the active opposition of a party headed by Colonel Walrod, he procured the passing of an Act acknowledging the king's sovereignty, the proprietary rights of the earl of Carlisle, and his own interest derived from the latter. But the Parliament despatched Sir George Ayscue with a squadron and considerable land forces, to reduce the island to submission to its authority. About the same time the famous Navigation Law was enacted, by which foreign ships were prohibited from trading with British colonies, and imports into England and the dependencies were not allowed in foreign bottoms. This restriction had a great effect upon Barbados, which depended upon foreign importation for a great deal of its provisions. Sir G. Ayscue's expedition appeared off Barbados in October 1651. After one unsuccessful attempt, a landing was effected, and Lord Willoughby's force was routed. The counsels of a moderate party in the island, however, prevailed, and a compromise was effected. A treaty was made declaring the authority of the Parliament, but containing provisions not at all unfavourable to the inhabitants, and reserving even to Lord Willoughby his rights in the island. During the Commonwealth prisoners of war were sometimes sent to Barbados. The expedition of 1655 against St Domingo and Jamaica under Penn and Venables was reinforced by a troop of horse and 3500 volunteers from Barbados. At the Restoration Lord Willoughby went out once more to Barbados and resumed his office. Several of the faithful adherents of the royal cause in the island were made baronets and knights, but the restrictions upon commercial intercourse which had been imposed by the Parliament were made more stringent. Then doubts began to arise in the minds of the planters as to the title by which they held their estates. They had created by their exertions a very valuable property, and the bare possibility of the earl of Carlisle stepping in and dispossessing them caused much discontent. The death of Lord Carlisle brought matters to a crisis. An arrangement was made in 1663 by which the different claimants were satisfied, the proprietary or patent interest was dissolved, and the Crown exercised directly its rights, and undertook the government, although it was not till 1672 that the nomination of the council was taken into the hands of the king. A duty of  $4\frac{1}{2}$  per cent. upon the produce of the island was levied in 1663 to satisfy the claims and defray the government expenses. Lord Willoughby received a new commission, and the only practical change effected in the constitution was that all laws were thenceforward made subject to confirmation by the king. In 1665 the colony successfully resisted an attack by the Dutch; but in conducting an expedition against the French in Guadeloupe in 1666, Lord Willoughby was lost in a hurricane, and an eventful and occasionally brilliant career was thus prematurely ended. He was succeeded in the government by his brother, Lord William Willoughby, during whose governorship the division of the Caribbean Islands into Windward and Leeward was made. The hurricane of 1675 gave a serious check to the prosperity of the

colony. An unsuccessful application was made to the home Government, to remit, on account of the distress that prevailed, the  $4\frac{1}{2}$  per cent. duty, which pressed very heavily upon the planters. The island had scarcely recovered from the effects of the hurricane when the supply of labour was restricted and its expense increased by the Royal African Company, at the head of which was the duke of York, receiving a charter for the exclusive supply of slaves to the West India Islands. This company had great influence in the appointment of governors; and in consequence of oppressive proceedings and depreciation of the value of property, many families left the island. A number of persons implicated in the duke of Monmouth's rebellion were sent to Barbados and treated harshly. Duties upon sugar were imposed by the mother country, which were increased at the accession of James II., to 2s. 4d. per cwt. on Muscovado, and to 7s. upon all sugars for common use. From the survey made by governor Sir Richard Dutton in 1683-4, it appears that the population consisted of 17,187 free, 2381 unfree and servants (prisoners of war and persons brought from England under engagements for terms of years), and 46,602 slaves. The number of acres in useful possession was 90,517, and of sugar-works 358. These figures show how rapidly, in spite of all difficulties, the colony had grown in sixty years.

The wars in Europe were reproduced upon a smaller scale, though with equal if not greater intensity, among the different nationalities in the West Indies. In such times the seas swarmed with privateers; and freights were so high as to induce the island Legislature to make a vain attempt to regulate them by law. The news of the peace of Ryswick was received with great joy, and matters remained quiet until the declaration of war against France and Spain in 1702 revived privateering in West Indian waters. Events in the first half of the 18th century do not call for detailed description. It was the custom of the assembly to supplement the salary of the governor (which was paid by the Crown out of the  $4\frac{1}{2}$  per cent. duty) by special grants; sometimes of large amount. But this did not prevent many constitutional conflicts between the assembly and the executive. During the war which commenced between England and France in 1756, the West Indies witnessed much fighting, with its attendant suffering. In 1761 a determined attempt was made to break the power of France in the archipelago. Barbados entered with enthusiasm into the project. Guadeloupe had been taken in 1759, and the principal effort now, under Admiral Rodney and General Monckton, was directed against Martinique. In 1762 that island surrendered. Barbados spent £24,000 in raising and equipping her proportion of men in the attacking forces; and in 1765 the House of Commons voted £10,000 as compensation for the expense incurred. By the Treaty of 1763, however, both these islands were restored to France. The constant wars had naturally an injurious effect upon Barbados. During the governorship of the Hon. Edward Hay, who was appointed in 1773, differences of opinion arose as to the state of the island. When the war between England and the American colonies began, the supply of provisions, upon which Barbados depended, necessarily stopped. The assembly addressed a petition to the king, praying for relief; through the interposition of the governor the relief was not immediately granted, but in 1778, when the island was in a very depressed state, the British ministry sent a quantity of provisions for sale at prime cost. With the advent of General Cunningham as governor another series of contentious years began. In the midst of disputes as to the right of the governor to exact certain fees without the consent of the assembly, a hurricane visited the island and

caused much destruction of property. Parliament in 1782 granted £80,000 for relief, but an attempt to obtain the repeal of the 4½ per cent. duty was again unsuccessful. The French were regaining their ascendancy in the archipelago, and had it not been for the great naval victory won by Sir George Rodney, Barbados and the remaining British colonies might have fallen to the enemy. As the 18th century closed, the prospect of the great final struggle with France overshadowed the colonies. The Barbadians energetically put themselves in a state of defence, and at the same time voted and privately subscribed money to assist his Majesty to carry on the war. The peace of Amiens, in 1802, relieved anxiety for a brief interval, but hostilities were soon renewed. When in 1805 Napoleon sent a squadron to the archipelago, with 4000 soldiers, the crisis put Barbados on her mettle. The French fleet was successful in exacting large sums of money from adjacent colonies. Admiral Villeneuve, too, was on his way with a still larger fleet and stronger force. But when Admiral Cochrane arrived off Barbados the safety of the island was secured. Even amid the intense excitement of these events constitutional questions were not forgotten. The governor could only establish martial law when the enemy's fleet was in sight. A premature declaration drew forth a protest from the assembly, and the controversy was only ended when the Home Government asserted the full prerogative of the Crown to impose martial law when necessary for the safety of the island. The most memorable event in 1805 was a flying visit from Lord Nelson in search of a French fleet. In October of the same year the battle of Trafalgar was won, and Bridgetown soon after had its Trafalgar Square and its Nelson statue. In 1809 an expedition sailed from Barbados, under Governor Beckwith, against the French in Martinique. After a bombardment of five days that place was taken. Twelve months later Beckwith similarly attacked Guadaloupe; and when that island was conquered, after some hard fighting, the power of the French in the archipelago was again reduced to its lowest ebb. When the war ended in 1810 in the West Indies, the British were supreme in that region. But danger was threatened from another source. The rupture between Great Britain and the United States in 1812 caused privateering to be resumed to an extent that almost destroyed the commerce of the island, until the abdication of Napoleon and the peace with America in 1814 again brought relief to the colonies. The military history of Barbados ceased at the close of the Peninsular War.

In the meantime Barbadian affairs had attracted notice in Parliament. In 1812 a motion was made in the House of Commons that the 4½ per cent. duty should be applied exclusively to local purposes. A considerable amount of this revenue had been devoted to pensions to persons entirely unconnected with the colony, and it was stated in the House of Commons that part of the money had been appropriated to the king's household in the reign of William III. Nor were the Barbadians themselves backward in stating their grievances. In 1813 they protested against the importation of East Indian sugars into Great Britain, and also against the system of patent offices, by which non-resident officials were able to draw large sums from the island for services which they never performed. By Act of the Parliament 6 Geo. IV. c. 114, 1825, foreign commodities were admitted into the British possessions at moderate rates of duty if the countries sending those articles would give similar privileges to British ships. As the United States refused reciprocity, the West Indian ports were closed against their vessels, and the United States retaliated by prohibiting all intercourse with British colonies. From the operation of the above-mentioned Act an important constitutional question arose. These duties, levied in the

name of the king, were to be paid into the local treasury for the uses of the colony, but the customs officers, of course appointed from home, received instructions to retain their own salaries from the revenue. This was denounced by the assembly as illegal, and after a long controversy it was agreed, in 1832, that 10 per cent. should be deducted to defray the expense of collecting the tax. Another question arose which illustrates the relations between England and the colony. By an island Act of 1773, a 2s. 6d. tonnage duty was imposed, but small vessels belonging to residents were only to pay on three voyages a year. By an Act of Parliament in 1832 this exemption was abolished. The assembly protested and denied the right of Parliament to tax colonies which had representative institutions; but Lord Stanley, in 1833, declared that this right existed, although its exercise was a matter of expediency. After the hurricane of 1831, which was perhaps the severest the island had ever experienced, causing 1591 deaths and a destruction of property estimated at more than a million and a half sterling, another urgent appeal was made for the remission of the 4½ per cent. duty, but without effect, although £100,000 was granted by Parliament in 1832 for the relief of the islands which had suffered from the visitation; of this sum Barbados took half. By an Act of Parliament passed in 1838, the 4½ per cent. duty was at length removed, after having been in existence for 175 years.

But a social revolution had begun which was destined to change not so much the prosperity of the colony, as the conditions under which that prosperity arose. From the first settlement, of course, the one great want was labour. As the labour supply increased and became more certain the cultivation expanded, wealth was created, and the importance of the colony grew. In the early days white labour was employed, assisted by Indians obtained from other islands and the mainland of South America, but when the sugar-cane began to be cultivated, negro slaves were imported from Africa. This slave trade, mostly conducted by companies or persons in England, continued until the year 1806, when it was stopped by Act of Parliament. In that year there were 60,000 negroes in the island. This measure was, of course, the first step to the abolition of slavery itself. On the 1st August 1834, the great Act of Emancipation came into force, and four years of apprenticeship began. Out of the 20 millions granted for compensation, Barbados received £1,720,345, being an average payment of £20, 14s. on 83,176 slaves. In consequence of the large population and small extent of uncultivated land, emancipation had not in Barbados such a relaxing effect upon the industry of the negroes as it had in the more thinly-populated colonies. An efficient system of town and rural police was, however, essential. From the time of emancipation the negroes multiplied rapidly. In 1844, out of a total population of 122,198, at least 90,000 were negroes, among whom females were largely in excess. The population, notwithstanding an occasional epidemic and almost continuous emigration, has continued to increase, as the following census returns will show:—

Year.	White.	Coloured.	Black.
1851.....	15,824	30,059	90,056
1861.....	18,594	36,128	100,005
1871..	18,560	39,578	105,904

The density of the population in 1871 was therefore 966 to the square mile. The gross population at the end of 1873 was estimated at 170,000.

Production and commerce have undergone great fluctuations. Before the navigation laws the Dutch were good customers, but subsequently the greater part of the produce has been exported to England. In 1767 the total exports of sugar were 24,000 hhd. ; in 1805 they were 19,805 hhd. In 1808, probably in consequence of the stoppage of the slave trade, the exports fell to 13,996 hhd. In 1834 they were 28,341 hhd., and in 1846, with the prospect of

the equalization of the English sugar duties upon slave and free grown sugar, they fell to 21,996 hhd. From 1850 to 1873, the average quantity exported annually was 44,000 hhd. The crop of 1873 yielded only 87,337 hhd. The total values of imports and exports in 1850, 1860, and 1873 were as follows:—

	Imports.	Exports.
1850.....	£734,358	£831,534
1860.....	941,761	984,294
1873.....	1,193,814	1,024,083

Of the imports £366,189 were from the United Kingdom, £171,592 from British Colonies, £485,375 from the United States, and the remainder from other foreign countries. The exports were thus distributed:—£471,175 to the United Kingdom, £388,791 to British Colonies, and £164,166 to foreign countries, including £125,640 to United States. Of the total exports 65 per cent. consisted of native productions, sugar, molasses, and rum. The balance consists of the transit trade, which contributes largely and increasingly to the commercial business of the island. The number of ships entered from the United Kingdom in 1873 was 74, tonnage, 23,500; from United States, 181, tonnage, 40,725; from British-North American Colonies, 125, tonnage, 19,283; from West Indies and Guiana, 851, tonnage, 44,823. The total number of ships entered was 1406, with a tonnage of 153,400 tons. But in 1873 the crop was deficient. The figures for 1875 will show the employment of a much larger quantity of shipping.

Barbados is gradually becoming the central mart for all the Windward Islands, even Trinidad finding it more advantageous to derive her breadstuffs, &c., from this quarter, than to import them direct from the continent. There was formerly an extensive whale-fishery round the island, and recently attempts have been made to revive its importance. Many other fishes would afford an excellent return, but this source of wealth is in great measure neglected. The anchovy is frequently driven up in shoals on the coast. The flying-fish is one of the principal articles in the Bridgetown market; barracoundas, sharks, and conger-eels are also exposed.

The local government consists of a governor (who is also governor-in-chief of St Vincent, Grenada, Tobago, and St Lucia); a legislative council (the members of which form as well an executive council), appointed by the sovereign, and holding office during pleasure, and the house of assembly. In former times the council exercised judicial functions, but in 1841 a chief-justice was appointed, and recent improvements have relieved the council of their equity and nearly all their appellate jurisdiction. The island is still divided into 11 parishes, each of which sends two representatives to the assembly. In addition to the parishes, Bridgetown sends two members. The number of voters, with the necessary property qualification, is about 1850. The business of the legislature is conducted according to the forms of the English Parliament, even to the election of a speaker to preside over the assembly, the initiation of money bills in that house, and the assertion of the right to exclude strangers. The assembly is elected annually. The revenue of the island in 1873 was £128,676, derived mainly from import duties, tonnage and port-dues, licences, and rum duty. The expenditure was £121,796. The total parochial taxation in 1873 was £31,569, which brings the gross amount of general taxation to £155,245, being at the rate of £1, 9s. 1d. per acre, or 17s. 6d. per head of population. The island is free from debt. The judicial establishment includes a court of chancery, which is conducted according to the rules, and follows the decisions, of the English court; a court of common pleas, criminal sessions, &c. The common law of England, modified by local enactments, is in force in Barbados.

The Church of England is the prevailing form of religion in the island. In 1871 the population was thus classified:—Church of England, 144,080; Wesleyans, 12,267; Moravians, 4733; and Roman Catholics, 518. Each parish has a rector, and there are twenty-eight curates in the island, all paid by the colonial revenue. The other denominations are also now entitled to grants. In the early days of the plantation, the clergy were paid by one pound of sugar for every acre of land in their parish. The first bishop of Barbados (the diocese including other colonies) was the Right Rev. W. Hart Coleridge, who arrived in 1825, and remained till 1842, when the diocese was divided, and the bishopric of Antigua founded. Trinidad has recently withdrawn from the diocese of Barbados and the Windward Islands, and founded a separate bishopric. Education is extending in Barbados. There were in 1873, 79 primary schools with 8000 scholars on the register, and 67 infant schools, with 5500 scholars, but the average attendance is much smaller. The Government expenditure on these schools for the year was £4000. The principal educational establishment is Codrington College, founded by Colonel Christopher Codrington. He bequeathed two estates, known as Consett's and Codrington's, to the Society for the Propagation of the Gospel. They consisted of 763 acres, 3 wind-mills, sugar buildings, 315 negroes, and 100 head of cattle. The society came into possession in 1712. The will declared that the plantations were to be continued, and 300 negroes always kept upon them; that professors and scholars were to be maintained; and physic,

chirurgery, and divinity were to be studied and practised. The college was commenced in 1716, and has seen many vicissitudes. One of its principal objects has been the preparation of candidates for holy orders. There are several theological scholarships of the value of £30 per annum from the college funds, and three of similar value paid by the Colonial treasury. There is a school, recently assisted by the public funds, called the Codrington Collegiate Grammar School, in close connection with the college. Harrison's College, in Bridgetown, established on an old foundation, has been liberally supported by the Legislature, and promises useful results.

Ligon's *History of Barbados*, 1667; Oldmixon's *British Empire in America*, 1741; *A Short History of Barbados*, 1768; *Remarks upon the Short History*, 1768; *Poyuz's History of Barbados*, 1808; Capt. Thom. Southey's *Chron. Hist. of W. Indies*, 1827; Schomburgk's *History of Barbados*, 1848; Griffith Hughes, *Nat. History of Barbados*; *Maycock's Flora Barbadosensis*; *Patent Rolls*, Public Record Office; *Annual Reports*, "Colonial Possessions;" *Colonial Office List*; Governor Rawson's *Report on Population*, 1872, and *Rainfall*, 1874. (J. L. O.)

BARBAROSSA, meaning *red-beard*, the name of two celebrated Turkish corsairs of the 16th century. They were the sons of a Roumelian sipahi who had settled in Mitylene after the capture of that island by Mahomet II., and who appears to have embraced Islamism. The elder of the two is generally called Aruch, Hornk, or-Ouradjih; the name of the younger was Khizr, but he was afterwards called by the sultan *Khair-ed-deen*, meaning "one good in the faith," which was corrupted by the Christians into Hayraddin. The brothers early betook themselves to piracy; and after various successes and reverses, they acquired sufficient wealth and renown to enable them to fit out a small fleet with which they ravaged the shores of the Mediterranean, and became the pests of that sea. A richly laden vessel which they presented to the sultan at Constantinople procured for them honorary caftans and recognition of their services. About the year 1516, after having been for some time in the service of the bey of Tunis, they began to acquire considerable possessions on the coast of Africa. Hayraddin seized the island of Shershel, and Aruch gained a footing in Algiers. The latter began to extend his conquests into the district of Tlemessen or Tlemcen, and was resisted by the Arabs, who summoned the Spaniards of Oran to their assistance. Aruch fell in battle in 1518, and was succeeded at Algiers by Hayraddin, who, after the reigning prince, Selim, was removed (in what way is somewhat doubtful), consolidated his power by placing himself under the Sublime Porte. Solyman, who was delighted at obtaining so much territory at such a small cost, conferred upon Hayraddin the title of *Begler-bey* of Algiers. The power of the pirates rapidly increased; Algieria, a small island opposite Algiers, was taken from the Spaniards after an obstinate resistance, and was united with the mainland by a mole. The coasts of the Mediterranean were completely at the mercy of Barbarossa, who carried off immense numbers of slaves. In 1533, when Solyman was about to make war upon his great rival, Charles V., Hayraddin joined him with a number of ships. He was received with great honour, and made admiral (*capitan-pasha*) of the fleet. His greatest exploit was the capture of Tunis, in which he obtained a footing by adopting the cause of a rival prince. As soon as he had deposed Muley Hassan, the reigning sovereign, he seized the town for himself and held it despite the resistance of the people. Charles V., however, sent out a great fleet, under Andrea Doria, who retook the town after a protracted siege. Barbarossa escaped to Algiers, collected his fleet, and again swept the seas. He plundered the coasts of Italy, captured Castelnuova, and inflicted a severe defeat on Doria. He died at Constantinople 4th July 1546. (See Von Hammer, *Geschichte des Osmanischen Reiches*, iii. 164, *seq.*; also *Blackwood's Magazine*, vol. lii.) The Emperor Frederick I. is very frequently designated by the surname Barbarossa.

**BARBARY**, the general designation of that part of Northern Africa which is bounded on the E. by Egypt, W. by the Atlantic, S. by the Sahara, and N. by the Mediterranean, and comprises the states of Morocco, Algeria, Tunis, and Tripoli. The name is derived from the *Berbers*, one of the most remarkable races in the region. (See *AFRICA*, vol. i. p. 351, *ALGERIA*, *MOROCCO*, *TRIPOLI*, *TUNIS*.)

**BARBASTRO**, a fortified city of Spain, in the province of Huesca, on the River Vero, near its junction with the Cinca. It has an interesting cathedral and seven other churches, with several hospitals. It was recovered from the Moors in 1065. The brothers Argensola were born here. The inhabitants are chiefly employed in tanning and currying leather. Long. 0° 20' W., lat. 41° 54' N.

**BARBAULD**, Mrs ANNA LETITIA, was born at Kibworth-Harcourt, in Leicestershire, on the 20th June 1743. Her father, the Rev. John Aikin, was a Presbyterian clergyman, who conducted a private school at that place. He instructed his daughter very carefully, and besides the usual female accomplishments she acquired a good knowledge of Latin and a fair knowledge of Greek. In 1758 Mr Aikin removed his family to Warrington, to act as theological tutor in a dissenting academy there. In 1773 Miss Aikin, at the earnest request of her brother, Dr John Aikin, known as the author of the *Evenings at Home*, consented to publish some of her poems. The volume was very successful, four editions being called for in the course of the year. In 1774 she married the Rev. Rochemont Barbauld, a Presbyterian minister, descended from a French Protestant family who had settled in England. He had been educated in the academy at Warrington, and had recently been appointed to a church at Palgrave, in Suffolk. There he began a private boarding-school, in the work of which he was most ably assisted by Mrs Barbauld, who superintended the younger pupils. Among those who passed through her hands, and who looked back with pleasure to the instruction given by her, were Sir William Gell, Lord Denman, and William Taylor of Norwich. The *Hymns in Prose* and the *Early Lessons* were written by her about this time for the use of her young charges, and proved admirably adapted for the purpose of instructing children. They have been frequently reprinted. In 1785 she left England for the Continent with her husband, whose health had been seriously impaired. On their return after a residence of about two years, Mr Barbauld was appointed to a church at Hampstead, where they resided till 1802. In 1792 Mrs Barbauld assisted her brother Dr Aikin in the composition of the popular series *Evenings at Home*, but it is said, contributed only a few pieces. In 1795 she published an edition of Akenaide's *Pleasures of Imagination*, with a critical essay; and two years later, she edited in a similar manner Collins's *Odes*. In 1801, after their removal to Stoke Newington, she published a selection of papers from the English Essayists, and a selection from Richardson's correspondence, with a biographical notice. The critical remarks prefixed to these publications have been much admired; they are generally judicious, in good taste, and well expressed. In 1810 she published a collection of the *British Novelists*, with biographical and critical notices. In the following year she published her longest poem, entitled *Eighteen Hundred and Eleven*, depicting the political and social events of the time, and giving rather a gloomy view of the existing state and future prospects of Britain. The poem is in many respects scarcely worthy of the author's reputation. Mrs Barbauld died on the 9th March 1825; she had been a widow from 1808. A collected edition of her works, with Memoir, was published by her niece, Miss Lucy Aikin, in 2 vols., 1826. (See A. L. Le Breton, *Memoir of Mrs*

*Barbauld*, 1874; G. A. Ellis, *Memoir of Mrs A. L. Barbauld*, 1874.)

**BARBER**, one whose occupation it is to shave or trim beards. In former times the barber's craft was dignified with the title of a profession, being conjoined with the art of surgery. In France the barber-surgeons were separated from the perruquiers, and incorporated as a distinct body in the reign of Louis XIV. In England barbers first received incorporation from Edward IV. in 1461. By 32 Henry VIII. c. 42, they were united with the company of surgeons, it being enacted that the barbers should confine themselves to the minor operations of blood-letting and drawing teeth, while the surgeons were prohibited from "barbery or shaving." In 1745 barbers and surgeons were separated into distinct corporations by 18 George II. c. 15. The barber's shop was a favourite resort of idle persons; and in addition to its attraction as a focus of news, a lute, viol, or some such musical instrument, was always kept for the entertainment of waiting customers. The barber's sign consisted of a striped pole, from which was suspended a basin, symbols the use of which is still preserved. The fillet round the pole indicated the ribbon for bandaging the arm in bleeding, and the basin the vessel to receive the blood.

**BARBERINI**, the title of a powerful family, originally of Tuscan extraction, who settled in Florence during the early part of the 11th century. They acquired great wealth and influence, and in 1623 Maffeo Barberini was raised to the papal throne as Urban VIII. He made his brother, Antonio, and two nephews, cardinals, and gave to a third nephew, Taddeo, the principality of Palestrina. Great jealousy of their increasing power was excited amongst the neighbouring princes, and Odoardo Farnese, duke of Parma, made war upon Taddeo and defeated the papal troops. After the death of Urban in 1644 his successor, Innocent X., showed hostility to the Barberini family. Taddeo fled to Paris, where he died in 1647; but the others after a short period returned to Italy and had their property restored. The principality of Palestrina is still in the hands of the family; and their magnificent palace and library at Rome give evidence of their wealth and magnificence.

**BARBEYRAC**, JEAN, an able writer on the principles of natural law, was the nephew of Charles Barbeyrac, a distinguished physician of Montpellier, and was born at Béziers in Lower Languedoc, in 1674. He removed, along with his family, into Switzerland after the revocation of the Edict of Nantes, and there studied jurisprudence. After spending some time at Geneva and Frankfort-on-the-Main, he became professor of belles lettres in the French school of Berlin. Thence, in 1711, he was called to the professorship of history and civil law at Lausanne, and finally settled as professor of public law at Groningen. He died in 1744. His first published work of any extent was the curious *Traité du Jeu*, 1709, in which he defends the morality of games of chance. His fame rests chiefly on the preface and notes to his translation of Puffendorf's celebrated treatise *De Jure Naturæ et Gentium*. In fundamental principles he follows almost entirely Locke and Puffendorf; but he works out with great skill the theory of moral obligation, referring it to the command or will of God. He indicates the distinction, developed more fully by Thomasio and Kant, between the legal and the moral qualities of action. The principles of international law he reduces to those of the law of nature, and combats, in so doing, many of the positions taken up by Grotius. He rejects the notion that sovereignty in any way resembles property, and makes even marriage a matter of civil contract. Barbeyrac also translated Grotius's *De Jure Belli et Pacis*, Cumberland's *De Legibus Naturæ*, and Puffendorf's

smaller treatise on obligations. Among his own productions are a treatise, *De la Morale des Pères*, and a history of ancient treaties, contained in the *Supplément au grand corps diplomatique*.

**BARBIERI, GIOVANNI FRANCESCO** (otherwise called **GUERCINO**, from his squinting), an eminent historical painter, was born at Cento, a village not far from Bologna, in 1590. His artistic powers were developed very rapidly, and at the age of seventeen he was associated with Benedetto Gennari, a well-known painter of the Bolognese school. The fame of the young painter spread beyond his native village, and in 1615 he removed to Bologna, where his paintings were much admired. His first style was formed after that of the Carracci; but the strong colouring and shadows employed by Caravaggio made a deep impression on his mind, and for a considerable period his productions showed evident traces of that painter's influence. Some of his latest pieces approach rather to the manner of his great contemporary Guido, and are painted with more lightness and clearness. Guercino was esteemed very highly in his lifetime, not only by the nobles and princes of Italy, but by his brother artists, who placed him in the first rank of painters. He was remarkable for the extreme rapidity of his execution; he completed no fewer than 106 large altar pieces for churches, and his other paintings amount to about 144. His most famous piece is thought to be the *Sta Petronilla*, which was painted at Rome for Gregory XV. and is now in the Capitol. Guercino continued to paint and teach up to the time of his death in 1666. He had amassed a handsome fortune by his labours.

**BARBIERI, PAOLO ANTONIO**, a celebrated painter of still life and animals, the brother of Guercino, was born at Cento in 1596. He chose for his subjects fruits, flowers, insects, and animals, which he painted after nature with a lively tint of colour, great tenderness of pencil, and a strong character of truth and life. He died in 1640.

**BARBOUR, JOHN**, the author of the great Scottish national poem *The Bruce*, was born, probably in Aberdeenshire, about the beginning of the 14th century. He was a contemporary of Chaucer and Gower; but so little is known of his life, that the very date of his birth can be only approximately given as about 1316. In 1357, as we learn from a safe-conduct permitting him to visit Oxford for the purpose of study,<sup>1</sup> he held the position of archdeacon of Aberdeen. In 1364 he was again permitted to enter England for a similar purpose,<sup>2</sup> and in 1368 he received letters of safe-conduct authorizing him to pass through England on his way to France,<sup>3</sup> whither, it may be conjectured, he was proceeding in order to visit the famous university of Paris. From this date to his death, which took place probably in March 1395, notices of him are slightly more numerous. In 1373 he is described as holding the office of clerk of audit of the king's household.<sup>4</sup> About the same time he must have been busily engaged in the composition of his great work, for, as he himself tells us, his poem was more than half finished in 1375.

"In the tyme of the compiling  
Off this buk this Robert wes King;  
And off his kynrik passit was  
Fyve yer; and wes the yer off grace  
A thousand, thre hundyr, seventy  
And fyve, and off his eld sixty."

A sum of ten pounds, which was paid to the poet by the king's orders in 1377,<sup>5</sup> was in all probability a royal gift on the completion of the work. Barbour seems indeed to

have been well treated by his sovereign; he received a perpetual annuity of twenty shillings,<sup>7</sup> which he bequeathed to the dean and chapter of Aberdeen as payment of a yearly mass to be said for his soul, tithes of the parish of Bayne in the Garioch, and a crown wardship, always a lucrative office in these times. A further bounty of ten pounds a year during life, granted in 1388, was probably a reward on the completion of the poet's second large work, *The Bruce*. The cessation of payment of this annuity enables us to fix with some accuracy the date of Barbour's death.

*The Bruce*, which is Barbour's principal poem, although it is almost the sole authority for the events of the period, is not to be considered as merely a rhyming chronicle.<sup>8</sup> His theme was freedom and the liberation of his country from the dominion of a foreign people. The age of Bruce was the age of Scottish chivalry, and the king himself presented the most perfect model of a valiant knight. With such a crisis and such a hero, therefore, it is not surprising that Barbour should have achieved a work of lasting fame.

The poem begins with an account of the succession to the Scottish crown after the death of Alexander III. In this part of his poem Barbour has made a slight anachronism. He makes his hero compete with John Baliol for the crown of Scotland, while it was his grandfather, the Lord of Annandale, who unsuccessfully contested the right. Then follows a lamentable account of the desolation of the country and the oppression of the people by the English. Bruce's energetic actions to free his country, and his romantic adventures, which form so interesting an episode in Scottish history, are narrated with great minuteness, down to the battle of Bannockburn, which is described with all its interesting details. At this point the national epic properly ends; but Barbour further relates the expedition of Bruce to Ireland, and the exploits of Douglas and Randolph on the borders, and concludes with an account of the deaths of King Robert and his gallant knights.

The next in order of his writings was that before referred to, called *The Bruce*, of which it is believed no MS. exists, unless the supposition of Mr. Henry Bradshaw, librarian of the university of Cambridge, be correct, that about 2000 lines of two MS. *Troy-books*, by Lydgate, preserved in the Cambridge and Bodleian Libraries, form part of this poem. It appears to have comprised a genealogical history of the kings of Scotland, deducing their origin from the great mediæval hero, Brutus, son of Ascanius, and grandson of Æneas, supposed to have been the first king of Britain. The existence of such a work is fully established by various passages in Wyntown's *Chronicle*.

"This Nynus had a sone alsu,  
Sere Dardane lord of Frygia.  
Fra quham Barbere autely  
Has made a propyr Genealogy,  
Tyl Robert oure secownd kyng,  
That Scotland had in govercyng.

"Of Brutus lynage quha wyll her.  
He tuk the tretis of Barbere,  
Mad in-tyl a Genealogy  
Bycht wile, and mare perfytly  
Than I can on ony wys  
Wyth all my wyt to yowe dewya."

"The Stewartis orygynale  
The Archadekyne has trefyt hal  
In metyre fayre."<sup>9</sup>

It is also referred to by Barbour himself in the following passage:—

"Als Arthur, that throw chevalry  
Maid Bretane maistres and lady

<sup>1</sup> *Robert Scotlan*, i. p. 808.

<sup>2</sup> *Ibid.*, i. p. 886.

<sup>3</sup> *Ibid.*, i. p. 926.

<sup>4</sup> *Accounts of the Great Chamberlains of Scotland*, vol. ii. p. 19.

<sup>5</sup> *Barbour's Bruce*, p. 274, Jamieson's ed.

<sup>6</sup> *Boothgater Rolles*, No. 82.

<sup>7</sup> *Boothgater Rolles*, Nos. 177, 178.

<sup>8</sup> It contains the earliest notice of the ancient Celtic poetry of Scotland. See *Barbour's Bruce*, p. 48, Jamieson's ed.

<sup>9</sup> *Chronicle of Scotland*, ix. i., III. ff. 139, VIII. ff. 148.



Off twalf kinrykis that he wan ;  
 And alsua, as a noble man,  
 He wan throw batall France all fre,  
 And Lucius Yber wencuyst he,  
 That then of Rome was emperour.  
 Bot yett, for all his gret valour,  
 Modreyt his systir son him slew,  
 And gud men als ma than inew,  
 Throw tresoune and throw wikkitnes ;  
 The Broite beris thairoff wytnes."<sup>1</sup>

The last of the works of Barbour was his *Book of Legends of Saints*, which contained, as the author tells us—

"Stories of sere haly men  
 That to pless God vs may kena.

The manuscript of this work (which was brought to light a few years ago by Mr Bradshaw) is preserved in the library of the university of Cambridge. The *Legends* are contained in a tall, narrow volume of paper, closely written in an unmistakably Scottish hand, containing a great many thousand lines in the usual verse of Barbour. This, taken in connection with certain incidental notices which the writer gives of himself, and certain stories which he tells of what happened in his time, leaves little room for doubt as to the author. The following extract from the account of a cure performed by St Ninian upon a native of Elgin may be given as a specimen of these legends:—

"A lytil tale yit herd I tell  
 That in to my tyme befel  
 Of a gudman in Murete borne  
 In Elgyn and his kine beforen  
 And callit was a faithful man  
 Withall thame that hyme knew than  
 And this man trastely I say  
 For I kend hyme welle mome day  
 Johne Belormy ves his name  
 A man of ful gud fame  
 And in process of tyme tyd hyme  
 Til haf the worme in til his lyme  
 And wrocht as in his schank and kne  
 That bath ware that lyk tynt to be."<sup>2</sup>

The works of Barbour are interesting in a philological point of view. At one time they were regarded as the first written in what was termed the ancient Scottish, a special language, which was supposed to have been derived directly from the Sui-Gothic, or the Meso-Gothic of Ulphilas. The extraordinary circumstance, however, was that Barbour and other early Scottish poets, such as Wynthown, James I., and Lyndsay, speak of the language as "Ingliis." In *The Bruce* the following passage occurs:—

"This was the spek he maid perfay  
 As is in *Ynglis* toung to say."<sup>3</sup>

It is now generally admitted that these poets wrote in a language founded on the Anglo-Saxon of the northern type, and nearly identical with that spoken in the northern half of England, which was general from the Trent to the Forth, and northwards on the eastern coast as far as Aberdeen. In this extensive district a Doric dialect of English was general, and in the 14th century there was no greater difference between the written language of York and of Eastern Scotland than there is now between the modern speech of Aberdeen and Edinburgh.<sup>4</sup>

According to Warton,<sup>5</sup> Barbour has adorned the English language by a strain of versification, expression, and poetical imagery, far superior to the age. Dr Nott<sup>6</sup> remarks that he has given his countrymen a fine example

<sup>1</sup> Barbour's *Bruce*, p. 20, Jamieson's ed. In one of the MSS. of Lydgate is a note—"Her endis the monk and begynnys Barbour."

<sup>2</sup> *National MSS. of Scotland*, pt. ii. No. 75.

<sup>3</sup> Barbour's *Bruce*, iv. p. 252.

<sup>4</sup> For an estimate of the position of Barbour in the literature of the period, see Mitscher's *Altenglische Sprachproben*, i. p. 371.

<sup>5</sup> *Hist. of English Poetry*, ii. p. 154.

<sup>6</sup> *Disc. on English Poetry* prefixed to Surrey and Wyatt's *Poems*, p. 190.

of the simple, energetic style, which resembled Chaucer's best manner, and wanted little to make it the genuine language of poetry. Simplicity may be said to be the main feature in the plan and conduct of his poems. His story is throughout his first and chief object, and he shows great anxiety lest in any point of the actual adventures he may mislead his reader. He prays that he may say "nought bot suthfast thing," and he was the first who did so with some of the graces of the fables of romance. He has, however, a heart for every kind of nobleness. His far-famed encomium on political freedom is distinguished by a manly and dignified strain of sentiment:—

"A! fredome is a noble thing!  
 Fredome mayns man to haif liking,  
 Fredome all solace to man giffis:  
 He leyvs at eas that frely leyvis!  
 A noble hart may haif nane eas,  
 Na ellys nocht that may him pless,  
 Gyff fredome fallyhe; for fre liking  
 Is yharnt; our all othir thing.  
 Na he that ay has leyvt fre,  
 May nocht knaw weill the propyrtie,  
 The angry, na the wreycht dome  
 That is cowplyt to foule thyrdome:  
 Bot gyff he had assayt it,  
 Than all perguer he suld it wyt,  
 And suld think fredome mar to pryys  
 Than all the gold in warid that is."<sup>7</sup>

The following passage cannot be passed without particular notice; the annals of heroes furnish but few instances of so pleasing a nature, whether it be that heroes seldom stoop to actions of mere benevolence, or that their historians do not think it of much importance to transmit such actions to posterity:—

"The king has hard a woman cry;  
 He askyt quhat that wes in hy.  
 'It is the laynder, Sohyr,' said ane,  
 'That her child-ill rycht now has tane,  
 'And mon leve now behind ws her;  
 'Tharfor scho makys yone iwill oher',  
 The king said, 'Certeis it war pite  
 'That scho in that poyn left suld be;  
 'For certis I trow thar is na man  
 'That he ne will rev a woman than.  
 Hias ost all thar arestyt he,  
 And gert a tent sone stentit be,  
 And gert hyr gang in hastily,  
 And othyr women to be hyr by  
 Quhill scho wes deliner, he said;  
 And syne furth on his wayis raid:  
 And how scho furth suld caryt be,  
 Or euir he furth fur, ordanyt he.  
 This was a full gret curtesy,  
 That swilk a king, and sa mighty,  
 Gert his men duell on this maner  
 Bot for a pour lauderer."<sup>8</sup>

It has been stated that Barbour presents us with but few studies of natural scenery. His description of spring is, however, worthy of his muse, and contrasts favourably with any of the poetry of the period:—

"This wes in ver, quhen wynter tyde,  
 With his blastis hidwys to byde,  
 Was our-drywyn, and byrdis smale  
 As turturis and the nychtyngale,  
 Begouth rycht meraly to syng;  
 And for to mak in thair singyng  
 Swete notis, and sowmys seg,  
 And melodys plesand to her;  
 And the treis begouth to ma  
 Burgeons, and brycht blomys alsua,  
 To wyn the helyng off thair bewid,  
 That wykkyt wyntir had thaim rewid."<sup>9</sup>

Of Barbour's *Bruce* neither the original manuscript nor any contemporary copy is known to exist. It is a some-

<sup>7</sup> Barbour's *Bruce*, p. 10, Jamieson's ed.

<sup>8</sup> *Ibid.*, p. 320.

<sup>9</sup> *Ibid.*, p. 89.

what remarkable circumstance that the earliest specimen of Barbour's language is to be found in extracts inserted by Wyntown in his *Cronykil*, which may be set down as belonging to the year 1440.<sup>1</sup> A valuable manuscript of *The Bruce* is preserved in the Advocates' Library, Edinburgh, which was penned by John Ramsay in 1489. Ramsay is supposed to be the same person that was afterwards prior of the Carthusian monastery at Perth. This transcript is stated to have been executed at the request of Simon Lochmalony, vicar of Moonisie.

Another manuscript exists in the library of St John's College, Cambridge, and is dated 1487. The handwriting is very like that of the Advocates' Library manuscript, and from the initials of the transcriber being J. R., it is supposed that this is another transcript made somewhat earlier by the same scribe. This last manuscript affords perhaps the best readings, but each serves to correct errors and to supply omissions of the other.

The printed editions are almost a century later. The first known edition of *The Bruce* is believed to have been printed at Edinburgh in 1570-71, but of this only one imperfect copy is known to exist. The next known edition is that printed at Edinburgh by Andro Hart in 1616, only one copy of which is extant. Another edition was printed by Hart in 1620. Editions were issued by Andrew Anderson, Edinburgh, 1670, 12mo; Robert Saunders, Glasgow, 1672; Robert Freebairn, Edinburgh, 1715 or 1716 (issued with a false title page in 1758); Carmichael and Miller, Edinburgh, 1737. John Pinkerton issued an edition in 1790, printed at London, in 3 vols. 8vo, which he styles "the first genuine edition." It was taken from the Advocates' Library manuscript, but, as his transcript was executed neither by himself nor under his immediate inspection, many gross inaccuracies were suffered to remain uncorrected. Dr John Jamieson printed an edition at Edinburgh in 1820, in 4to. This was a careful print of the Advocates' Library manuscript. Mr Cosmo Innes printed an edition for the Spalding Club in 1856. It was made from a collation of the Advocates' Library and the Cambridge manuscripts. The Rev. W. W. Skeat is at present (1875) engaged in editing an edition for the Early English Text Society (extra series), 1870-75. This edition is founded on the Cambridge manuscript, carefully collated with the Edinburgh manuscript and with Hart's edition of 1616, and occasionally with Anderson's edition of 1670. (J. SM.)

BARBUDA, one of the lesser Antilles or Caribbean islands, is 10 miles in length by about 8 in breadth, presenting a very flat surface, covered to a great extent with woods, in which deer abound. Many varieties of shell-fish and other fish are found on the coast, which is also frequented by large flocks of water-fowl. The part of the island under cultivation is fertile; corn, cotton, sugar, tobacco, and indigo are grown; and the rearing of cattle is one of the principal occupations. So salubrious is the climate that Barbuda serves as a kind of *sanitarium* for the adjacent islands. The inhabitants, who number less than 2000, are mainly negroes. The island was annexed to Britain in 1628, and was bestowed in 1680 on the Codrington family, in whose possession it still remains. The north point is in lat. 17° 33' N. and long. 61° 43' W.

BARCA, a maritime district of Northern Africa, which formerly belonged to Tripoli, but was raised in 1869 to be a separate province immediately dependent on Constantinople. It extends from the Gulf of Sert (the ancient Syrtes) to the Egyptian frontier, between lat. 30° and 33° N. and between long. 20° and 26° E., and has an area of about 60,700 square miles. This territory is traversed

from east to west by a mountain chain varying in height from 400 or 500 to upwards of 1800 feet. A great part of Barca, particularly towards the coast, is very fertile, abounding with excellent pasturage, and producing large supplies of corn. The chief town is Bengazi.

BARCA, an ancient city in Cyrenaica, and within the above district, to which it gave name. Its ruins are now known as *El-Medinah*. It was situated between Cyrene (now *Grennah*) and Hesperides (now *Bengazi*), about 11 miles distant from the sea, on the top of the rising ground that overlooks the Syrtes. It was founded about 564 a.c. by a colony from Cyrene, who fled from the ill-treatment of Arceilaus II., and obtained the co-operation of a number of Libyans. About forty-four years after its foundation it suffered severely from the revenge of Pharetima, the mother of Arceilaus III., being captured and pillaged by the Persians, to whom she had appealed for assistance, while large numbers of its inhabitants were led captive to Bactria. In the time of the Ptolemies the founding of a new city, Ptolemais, on the sea-coast drew away from the older site a large part of the population; but Barca continued to exist for several centuries after the Christian era, and even seems to have risen again into importance under the Arabs. The ruins are few, and are thought to be those of the Arab city.

BARCELONA, formerly the capital of the kingdom of Catalonia, and now the chief town of the Spanish province to which it gives its name, is a flourishing city and seaport on the shore of the Mediterranean, in lat. 41° 22' N. and long. 2° 9' E., between the rivers Bésos (*Batulo*) on the north and the Llobregat (*Bubricatus*) on the south. It stands on the sloping edge of a small but fertile plain now covered with villas and gardens. Immediately to the south-east rise the Montjuich hills to the height of 650 feet, crowned by an important fortification; while on the west, the north, and the north-east, the view is bounded by the heights of San Pedro Martio, Valcanea, and Moncada. Barcelona was formerly surrounded by a strong line of ramparts, and defended, or, more correctly, overawed by a citadel on the north-east, erected in 1715 by Philip V. on Vauban's principle; but these fortifications being felt as a painful restriction on the natural development of the city, were, in spite of the opposition of the central Government, finally abolished by the local authorities in 1845. The walls of the moat were utilized for the cellars of the houses which soon occupied the site of the ramparts, and the ground, which had been covered by the citadel, was laid out in horticultural gardens. A rapid extension of the city to the north-west took place, and in 1860 an elaborate plan for the laying out of new districts received the royal sanction. Barcelona thus comprises an old and a new town, differing from each other in many important features, the former still consisting for the most part of irregular and narrow streets, while the latter has all the symmetry and precision of a premeditated scheme. The buildings of the old town are chiefly of brick, from four to five stories in height, with flat roofs, and other Eastern peculiarities; while in the new town hewn stone is very largely employed, and the architecture is often of a modern English style. To the south-east, on the tongue of land that helps to form the port, lies the suburb of Barceloneta. It owes its origin to the marquis de la Mina, who, about 1754, did so much for the city, and is regularly laid out, the houses being built of brick after a uniform pattern. The main street or axis of the old town is the *Rambla*, a favourite resort of the higher classes, which has a fine promenade planted with plane-trees running down the middle, and contains the principal hotels and theatres of the city. Among the most important of the squares are the Plaza de Palacio, the Plaza Real, and the Plaza del Teatro. The Paseo de San Juan and the Jardin del

<sup>1</sup> *Cronykil of Scotland*, book viii. c. 2 and 18.

General to the north-east of the town are being removed. The site of the former is to be occupied by a large market, while the latter is to be absorbed into the Park. Barcelona is the see of a bishop, and, like most Spanish towns, has a large number of ecclesiastical buildings, though by no means so many as it once possessed. If Barceloneta on



Ground-Plan of Barcelona.

the one hand, and Garcia, a suburban village, on the other, be included, the number of churches amounts to twenty-seven, and eighteen of these are *parroquias*, while no fewer than eighteen convents were still standing in 1873. The cathedral, erected between 1298 and 1448, but not yet finished, is a spacious building in the Pointed style, and contains the tomb of Santa Eulalia, the patron saint of the city. Its stained glass windows are among the finest in Spain, and it possesses archives of great value. Santa Maria del Mar, Santos Justo y Pastor, San Pedro de las Puellas, and San Pablo del Campo, are all churches worthy of mention. San Miguel in Barceloneta, which preserved a curious ancient mosaic and contained the tomb of the marquis de la Mina, has been taken down.

The educational institutions of Barcelona have from an early period been numerous and important. The university (*Universidad Literaria*) was originally founded in 1430 by the magistracy of the city, and received a bull of confirma-

tion from Pope Nicholas V. in 1450, possessing at that time four faculties and thirty-one chairs, all endowed by the corporation (*vide Capmany's Memorias*). It was suppressed in 1714, but restored in 1841, and now occupies an extensive building in the new town. There are, besides, an academy of natural sciences, a college of medicine and surgery,—confirmed by a bull of Benedict XIII. in 1400,—an academy of fine arts, a normal school, a theological seminary, an upper industrial school, an institution for the education of deaf-mutes, a school of navigation, and many minor establishments. Gratuitous instruction of a very high order is afforded by the Board of Trade to upwards of two thousand pupils. The principal charitable foundations are the *Casa de Caridad*, or House of Industry, the Hospital General, dating from 1401, and the Foundling Hospital. The *Montes de Piedad* are, in fact, mutual benefit societies; and that of *Nostra Señora de la Esperanza* has this peculiarity, that loans on deposits are made without interest to necessitous persons, thousands of whom yearly avail themselves of its advantages. The principal civic and commercial buildings are the *Casa Consistorial*, a fine Gothic hall, the *Lonsa*, or Exchange, dating from 1383, and the *Aduana*, or Custom-house, built in 1792. At the seaward end of the Rambla is a large ancient structure, the *Atarazanas*, or Arsenal, which was finished about 1243. A portion of it was recently taken down to give a better view to the promenade. Remains of the former royal state of Barcelona are found in the Palacio Real of the kings of Aragon, and the Palacio de la Reina. At the highest part of the city, in the Calle del Paradiis, are some magnificent columns, and other Roman remains, which, however, are hidden by the surrounding buildings.

The inhabitants of Barcelona are not only an intelligent and industrious, but a gay and pleasure-loving people. Means of public recreation are abundantly supplied. There are no fewer than fourteen theatres of more or less pretension, the two most important being the Teatro Principal and the Teatro del Liceo. The latter is a very fine building, originally erected in 1845 on the site of a convent of Trinitarian monks, and capable of containing 4000 spectators. A striking feature in Barcelona society is the development of social life; and the number of restaurants and similar places of evening resort is very great. A pleasant promenade is furnished not only by the Rambla but by the Muralla del Mar, or sea-wall, which was largely due to the marquis de la Mina, and is now undergoing extensive alteration by the reclaiming of a strip of land from the port.

Barcelona has long been the industrial and commercial centre of Eastern Spain—a pre-eminence which dates from the 12th and 13th centuries. It was the rival of Genoa and Venice, and in renown its hardy mariners were second to none. The origin of the famous code of maritime laws known as the *Consolado del mar* is usually, though not with absolute certainty, ascribed to its merchants; and it is pretty well established that they were the first to employ the method of marine insurance. We find them at an early period trading, not only with the ports of the Mediterranean, but with the Low Countries and England, on the one hand, and with Constantinople and Damascus, Egypt and Armenia, on the other,—entering into treaties with kings and magistracies, and establishing in all important places consuls to look after their interests. The prosperity so deeply rooted continued through numerous vicissitudes till the emancipation of the Spanish American colonies, when a comparative decline set in. This, however, proved only temporary, and, in spite of the disastrous consequences of the French invasion, and the various revolutions of the country since then, Barcelona has no need to look back with regret to the past. A great variety of

industries are now carried on—the most important being the spinning and weaving of wool, cotton, and silk. Of the numerous guilds that were anciently formed in the city an interesting list is to be found in Capmany. It carries on a large shipping trade. In 1872 between 700 and 800 foreign vessels, with a tonnage of 360,000 tons, discharged their cargoes in the port. Of these 160 were British. The imports from the colonies are sugar, cotton, tobacco, rum, wax, dye-wood, &c.; machinery, coals, coke, cotton, wool, thread, and other stuffs, are brought from England; articles of silk, chemical preparations, pastes and flours of all sorts, objects of fashion, wines and liquors, from France; petroleum, cotton, and staves from North America; cotton from the Brasils and Smyrna; hides from the River Plate; salt-fish from the North Sea. The export trade is not so extensive, consisting largely of fruits and vegetables, oil, silk, wines, salt, &c. The so-called port of Barcelona was at first only an open beach, slightly sheltered by the neighbouring hills, but at an early period the advantage of some artificial protection was felt. In 1438 we find Don Alphonso V. granting the magistracy a licence to build a mole; and in 1474 the *Moll de Santa Creu* was officially commenced. Long after this, however, travellers speak of Barcelona as destitute of a harbour; and it is only in the 17th century that satisfactory works were undertaken. Down to a very recent period all the included area was shut off from the open sea by a sand-bank, which rendered the entrance of large vessels impossible. An extension of the former mole, and the construction of another from the foot of Montjuich, have embraced a portion of the sea outside of the bank, and a convenient shelter is thus afforded for the heaviest men of war. The depth in this part is about 40 feet, while within the sandbank it is from 18 to 20. Barcelona is well supplied with inland communication by rail, and the traffic of its own streets is largely facilitated by tramway lines running from the port as far as Garcia.

According to traditions preserved by the Roman writers, Barcelona owed its origin, or at least its first importance, to the Carthaginians under Hamilcar Barca, after whom it was called *Barcino*. It received a Roman colony, and was known by the name of *Faventia*. After having shared in the various vicissitudes of the barbaric invasions, it became the capital of a dukedom under Louis the Pious, and not long after began to give the title of count to a family that soon made itself independent. In 985 the city was captured by the Moors, but not long after it was recovered by Count Borell. In 1151 Raymond Berenguer married the daughter of Ramiro II. of Aragon, and thus the countship of Barcelona was united to that kingdom by his son. From the successive princes of the line the city received many privileges. In 1640 Barcelona was the centre of the Catalonian rebellion against Philip IV., and threw itself under French protection. In 1652 it returned to its allegiance, but was captured by the duke of Vendôme in 1697. At the peace of Ryswick, in the same year, it was restored to the Spanish monarchy. During the War of the Succession Barcelona adhered to the house of Austria. The seizure of Montjuich in 1705 and the subsequent capture of the city by the earl of Peterborough formed one of his most brilliant achievements. In 1714 it was taken after an obstinate resistance by the duke of Berwick in the interests of Louis XIV., and at the close of the war was reluctantly reconciled to the Bourbon dynasty. At the commencement of Bonaparte's attempt on the liberty of Spain, the French troops obtained possession of the fortress, and kept the city in subjection. Since then it has shared in most of the revolutionary movements that have swept over Spain, and has frequently been distinguished by the violence of its civic commotions. By the census

of 1857 the population of the city amounted to 180,014, and by an enumeration in 1864 the city and suburbs were found to contain 252,000 persons. (See *Manifestacion de muchos relevantes servicios de Barcelona*, Barcelona, 1697; Capmany, *Memorias historicas sobre Barcelona*, 1779–92; Chantreau, *Lettres de Barcelonne*, 1793; Hare, *Wanderings in Spain*.)

BARCLAY, ALEXANDER, an English poet, was born probably about 1476. His nationality has been matter of much literary dispute, but the evidence on the whole seems to point to the conclusion that, though he spent the greater part of his life in England, he was a native of Scotland. The place of his education is equally doubtful; he studied at one of the great English universities, but at which has not yet been settled by his biographers. He received a benefice from the provost of Oriol College, Oxford, and it might therefore be inferred that he had been a student at that place. But Oxford is nowhere referred to in his writings, whereas Cambridge is mentioned once. He appears to have travelled on the Continent after completing his university course, and on his return received an appointment as chaplain in the collegiate church at Ottery St Mary in Devonshire. He afterwards became a Benedictine monk of the monastery of Ely, and at length assumed the habit of St Francis at Canterbury. Having survived the dissolution of the monasteries, he became successively vicar of Much-Badew in Essex, and, in 1546, of Wokey in Somersetshire; and a few months before his death he was presented by the dean and chapter of Canterbury to the rectory of All-Saints in Lombard Street. As he retained some of his preferments in the reign of Edward VI., it is presumed that he must have complied with the changes of the times. He died at an advanced age in the year 1552, and was interred at Croydon. Barclay wrote at a period when the standard of English poetry was extremely low; and, as excellence is always comparative, this circumstance may partly enable us to account for the high reputation which he enjoyed among his contemporaries. At the same time his best work, being a comprehensive and easily understood satire on the manners of the times, naturally acquired a wide popularity, and was extensively read. The title given to it was the *Ship of Fools*, and it was first printed by Pinson in 1509. The original design, and many of the details, were derived from Sebastian Brandt, a civilian of Strasburg, who in 1494 published a poem entitled *Das Narren Schifff*, which was so well adapted to the taste of the age that a Latin and a French version appeared in 1497, and another French version in 1498. Barclay professes to have translated "oute of Laten, Frenche, and Doche;" but to the original cargo he has added many foals of English growth. Under the representation of a ship freighted with foals of various denominations, the poet exposes the prevalent vices and follies of the age; and although, as Warton remarks, the poem is destitute of plot and the voyage of adventures, the general design was found to possess many attractions. The work is of considerable importance, as giving a clear though by no means pleasing picture of English society and lower class life in the time of Henry VIII., and also as marking a stage in the progress of the English language. Barclay's vocabulary is essentially that of the people. His other works are—*The Castell of Laboure*, 1506; *The Mirrour of Good Manners*, translated from the poem of Mancini *De quatuor Virtutibus*; *The Egloges*; a version of Sallust; an *Introduction to Write and to Pronounce Frenche*; and some small pieces. A catalogue of all these, with full notice of the little that is known concerning Barclay, and ample bibliographical information, is supplied by Mr Jamieson in the introduction to his edition of the *Ship of Fools*, Edin., 1874.

BARCLAY, JOHN, a distinguished scholar and writer, was born, January 28, 1682, at Pont-à-Mousson, where his father William Barclay (see below) was professor of civil law. Educated at the Jesuits' college, he gave evidence of remarkable ability at an early age, and was only nineteen when he published a commentary upon the *Thebasis* of Statius. The Jesuits were naturally desirous that he should enter their order, but to this both himself and his father were averse. The jealous enmity of the order was roused against them in consequence of this refusal, and in 1603 both left France and crossed over to England. In the following year they returned and settled at Angers, where Barclay's father had been appointed professor of law. Soon after the death of his father in 1608, Barclay appears to have married, and to have settled in London, where in 1606 he published the second part of his *Satyricon*, the first part having appeared on his previous visit to England. In 1610 he edited an important treatise left by his father, *De Potestate Papa*, which involved him in controversy with the famous Cardinal Bellarmine. In 1614 appeared the wittiest and most interesting part of the *Satyricon*, entitled *Icon Animorum*, which gives a critical survey of the varied manners and characteristics of the several European nations. It has been frequently reprinted. In 1616, after a short stay in Paris, he proceeded to Rome, where he continued to reside till his death on 12th August 1621. His romance, *Argensis*, was passing through the press at the period of his death, and it appeared in the course of the same year. Barclay, from what reason is not apparent, failed to attain the position to which his talents seemed fairly to entitle him. His reputation as a writer and scholar was remarkably high among his contemporaries. Grotius and others have lavished praises on the purity and elegance of his Latin style; his romance was extremely popular; and some of his Latin poems are very happy. The idea of the *Satyricon*, one of his two extensive compositions, is borrowed from Petronius; in the details, however, the work fortunately does not follow that author so closely. It was very extensively read, and has passed through several editions. The *Argensis*, a long Latin romance, sometimes looked on as a political allegory, was very popular. It is said to have been warmly admired by Richelieu and Leibnitz, while Cowper, Disraeli, and Coleridge speak of it in terms of high admiration. The value that was put upon it by Barclay's contemporaries and immediate successors may be gathered from the critical estimate of it given in the *Vita Barclayii*, prefixed to later editions of the work. "*Habet enim*," says the anonymous writer of the life, "*heroicum Tullii vigorem, Laconismum et politiam Taciti, Livii antiquitatem, floeculos pueros Petronii, sales fabulosos Nasonis, poeticam Maronica vis inferiorem.*" There have been numerous editions of the book, which has been translated into almost every European language.

BARCLAY, JOHN, M.D., an eminent anatomist, was born in Perthshire in 1760, and died at Edinburgh in 1826. After the usual routine of parochial education, he completed his academic course at the United College of St Andrews. He subsequently studied divinity there, and was licensed as a preacher by the Presbytery of Dunkeld. Having repaired to Edinburgh in 1789, as tutor to the family of Sir James Campbell of Aberuchill, he began to give his attention to the study of medicine, and particularly to human and comparative anatomy. He became assistant to Mr John Bell, and took the degree of M.D. in 1796, after having defended an inaugural dissertation, *De Anima seu Principio Vitali*, a subject which occupied his maturer powers towards the close of his life. Immediately after his graduation, he repaired to London, and studied for some time under Dr

Marshall, at that time a very distinguished teacher of anatomy in the metropolis. Soon after his return to Edinburgh, he commenced his lectures on anatomy in November 1797, and speedily attracted an audience, which increased considerably in numbers until the period of his retirement, a short time before his death.

Of Barclay's professional writings, the earliest, we believe, was the article *PHYSIOLOGY*, contributed to the third edition of this work. In 1808 he attempted a reform in the language of anatomy, with a view to render it more accurate and precise,—a task for which his acquirements as a classical scholar rendered him peculiarly well qualified. Although the *Nomenclature* which he published in that year has not been generally adopted, the profession acknowledged the importance of the object which he had in view, as well as the talent and learning with which it was executed. In 1808 he published his *Treatise on the Muscular Motions of the Human Body*, and in 1812 his *Description of the Arteries of the Human Body*, a work displaying much acute observation and laborious research, which may be considered the most practically useful of all his writings. His last publication, completed only a few years before his death, was *An Inquiry into the Opinions, Ancient and Modern, concerning Life and Organization*, a work replete with learning and sound original criticism. His introductory lectures published after his death contain a valuable abridgment of the history of anatomy.

BARCLAY, JOHN, founder of a small sect in the Scotch Church called Bereans or Barclayites, was born in Perthshire in 1734, and died at Edinburgh in 1798. He graduated at St Andrews, and after being licensed became assistant to the parish minister of Errol in Perthshire. He developed some very peculiar views, which led to a difference with the minister; and in 1763 he left and was appointed assistant to Mr Dow of Fettercairn. In this parish he became very popular, but his opinions, whether as expounded from the pulpit, or as set forth in a paraphrase of some Psalms which he published, failed to give satisfaction to his Presbytery. In 1772 he was rejected as successor to Mr Dow, and was even refused by the Presbytery the testimonials requisite in order to obtain another living. The refusal of the Presbytery was sustained by the General Assembly, and Mr Barclay thereupon left the Scotch Church. He preached in Edinburgh, London, Bristol, and other places, but with no great success. Neither his writings, which were collected in three volumes, nor the sect formed by him, are of much importance. His adherents were called Bereans, because they regulated their conduct as the inhabitants of Berea are said to have done, by diligently searching the Scriptures (Acts xvii. 11).

BARCLAY, ROBERT, one of the most eminent writers belonging to the Society of Friends, or Quakers, was born in 1648 at Gordonstown in Morayshire. He was sent to finish his education in Paris, and it appears he was at one time inclined to accept the Roman Catholic faith. In 1667, however, he followed the example of his father, Colonel Barclay of Urie, and joined the recently formed Society of Friends. He was an ardent theological student, a man of warm feelings and considerable mental power, and he soon came prominently forward as the leading apologist of the new doctrine. His greatest work, *An Apology for the True Christian Divinity*, was published in Latin in 1676, and was an elaborate statement of the grounds for holding certain fundamental positions, laid down in the *Theses Theologicae* which had been put forward in the preceding year. The most prominent of the *Theses* was that bearing on Immediate Revelation, in which the superiority of this Inner Sight to Reason or Scripture is sharply stated. Barclay experienced to some extent the persecutions inflicted on the new society, and was several times thrown into prison. He died in 1690 at the early age of forty-two. His *Apology*, which is still the most important manifesto of the Quaker society, was translated by himself into English in 1678. Translations of it into foreign languages have also appeared.

**BARCLAY, WILLIAM, LL.D.**, a writer on civil law, was born in Aberdeenshire in the year 1541. He spent the early part of his life, and much of his fortune, at the court of Mary queen of Scots, from whose favour he had reason to expect preferment. In 1573 he went over to France, and at Bourges began to study civil law under the famous Cujas. He continued some years in that seminary, where he took his doctor's degree; and was soon after appointed professor of civil law in the university of Pont-à-Mousson, recently founded by the duke of Lorraine. The prince afterwards made him counsellor of state and master of requests. In the year 1581 Barclay married Anne de Malleville, a French lady. Their son was the celebrated John Barclay, author of the *Argenis*. This youth the Jesuits would gladly have received into their society; but his father refused his consent, and thereby incurred their bitter enmity. He was compelled to leave France, and returned to Britain, where King James offered him a considerable preferment, provided he would become a member of the Church of England. He would not accept the post on this condition, and went back again to France in 1604. Soon after his arrival he was appointed first professor of the civil law in the University of Angers, where he died the year following, and was buried in the Franciscan church. Barclay was a man of considerable ability, and his legal writings are still valued. In his political opinions he was directly opposed to his illustrious countryman Buchanan, and was a strenuous defender of the rights of kings; his own speculations on the principles of government are best known to some from an incidental confutation by Locke, in his *Treatises on Government*. His most important writings were:—

*De Regno et Regali Potestate, adversus Buchananum, Brutium, Boucherium, et reliquos Monarchomachos, libri sex*, Paris, 1600, 4to; *In Titulum Pandectarum de Rebus creditis et Jurisjurando Commentarii*, Paris, 1605, 8vo; *De Potestate Papæ; an et quatenus in Reges et Principes secularis jus et imperium habeat: Liber posthumus*, Namipontii, 1610, 8vo. This work was translated into French, and an English version is printed with the treatise of Sheldon, *Of the Lawfulness of the Oath of Allegiance*, Lond. 1611, 4to. Barclay's two treatises, *De Regno* and *De Potestate Papæ*, have repeatedly been printed in the same volume: Hanover, 1612, 8vo; Hanover, 1617, 8vo.

**BARCLAY DE TOLLY, MICHAEL**, a Russian prince and general, highly distinguished in the wars with Napoleon, was born in Livonia in 1759. He was a descendant of the old Scotch family of Barclay, a branch of whom had settled in Russia in the 17th century. He was adopted by General Vermoulen, and entered a Russian cuirassier regiment when very young. In 1788 and 1789 he served against the Turks, and in the following years against the Swedes and Poles, In 1806, when Russia took up arms against Napoleon, he commanded the advanced guard at the battle of Pultusk. At Eylau he lost an arm, and was promoted to the rank of lieutenant-general. In 1808 he commanded against the Swedes, and in 1809 by a rapid and daring march for two days over the ice he surprised and seized Umeo. In 1810 he was made minister of war, and retained the post till 1813. There was very keen opposition to the appointment of a foreigner as commander-in-chief, and after the defeat of Smolensk, the outcry was so great that he resigned his office and took a subordinate place under the veteran Kutusoff. On the death of the latter he was reappointed to the supreme command, and fought at the battles of Bautzen, Dresden, and Leipsic. He was unable to bring up his forces in time for the battle of Waterloo, but marched into France and took part in the occupation of Paris. He was rewarded for his services by being made prince and field-marshal. He died in 1818 at Insterburg, in Prussia, while on his way to the Bohemian baths.

**BAR-COCHEBAS, or BAR-COCHAB** (*Son of a Star*), a celebrated Jewish leader in the insurrection against Hadrian,

131-135 A.D., whose real name was Simeon. The events of his life belong to the history of the Jews.

**BARD**, from the Welsh *bardd*, is the name applied to the ancient Celtic poets, though the word is sometimes loosely used as synonymous with poet in general. So far as can be ascertained, the title *bards*, and some of the privileges peculiar to that class of poets, are to be found only among Celtic peoples. The name itself is not used by Cæsar in his account of the manners and customs of Gaul and Britain, but he appears to ascribe the functions of the bards to a section of the Druids, with which class they seem to have been closely connected. Later Latin authors, such as Lucan (*Phar.*, p. 447), Festus (*De Verb. Sigm. &c.*), and Ammianus Marcellinus (bk. xv.), used the term *Bardi* as the recognized title of the national poets or singers among the peoples of Gaul and Britain. In Gaul, however, the institution soon disappeared; the purely Celtic peoples were swept back by the waves of Latin and Teutonic conquest, and finally settled in Wales, Ireland, Brittany, and the north of Scotland. There is clear evidence of the existence of bards in all these places, though the known relics belong almost entirely to Wales and Ireland, where the institution was more distinctively national. In Wales they formed an organized society, with hereditary rights and privileges. They were treated with the utmost respect, and were exempt from taxes or military service. Their special duties were to celebrate the victories of their people, and to sing hymns of praise to God. They thus gave poetic expression to the religious and national sentiments of the people, and therefore exercised a very powerful influence. The whole society of bards was regulated by laws, said to have been first distinctly formulated by Hywell Dha, and to have been afterwards revised by Gruffydd ap Conan. At stated intervals great festivals were held, at which the most famous bards from the various districts met and contended in song, the umpires being generally the princes and nobles. Even after the conquest of Wales, these festivals, or *Eisteddfodau*, as they were called, continued to be summoned by the English sovereigns, but from the reign of Elizabeth the custom has been allowed to fall into abeyance. They have not since been summoned by royal authority, but have been revived, and are held regularly at the present time. In Ireland also the bards were a distinct class with peculiar and hereditary privileges. They appear to have been divided into three great sections: the first celebrated victories and sang hymns of praise; the second chanted the laws of the nation; the third gave poetic genealogies and family histories. The Irish bards were held in high repute, and frequently were brought over to Wales to give instruction to the singers of that country.

See Ed. Jones, *Relics of the Welsh Bards*, 1784; Walker, *Memoirs of the Irish Bards*, 1786; Owen Jones, *Myrrhian Archaeology of Wales*, 3 vols., 1801-7; W. F. Skene, *Four Ancient Books of Wales*, 2 vols., 1868.

**BARDESANES, or BAR DEBAN**, a celebrated Gnostic, was a native of Edessa in Mesopotamia, and appears to have flourished during the reign of Marcus Aurelius. Very little is known of his life. He is said to have held a disputation with Apollonius, a philosopher in the train of Lucius Verus, and he is known to have written against the Marcionite and other heresies. There is considerable doubt whether he was ever a disciple of Valentinus, but it is acknowledged that he never ceased to belong to the Christian church. However seriously his principles, if rigidly interpreted, might conflict with the doctrines of Christianity, he did not regard himself as opposed to that faith, and he was generally considered one of its best defenders. He was especially famed for his hymns, fragments of which are still extant. Of his other works

there seems to remain only a treatise *On Fate*, a portion of which was preserved by Eusebius (*Prep. Evang.*, vi. 10), while the whole has been printed from a Syriac MS. with English translation by Cureton (*Spicilegium Syriacum*, Lond. 1855). The system of Bardesanes, so far as it can be gathered from the scanty notices of other writers, had many points in common with that of Valentinus, but shows to an almost greater extent the influence of Oriental mysticism and imagery. He begins, as do all the other Gnostics, with postulating the existence of the Unknown God or Father, the ground of all the forms of being. Alongside of God, and co-existing with Him,—in fact, His necessary shadow,—is vague, unformed, eternal, and uncreated Matter. From this dualism springs the possibility of evil in the universe. Evil is not, indeed, correlative and equally necessary with God, but arises from matter. The Eternal Father, through union with His everlastingly produced, but shadowy companion, brings forth the Son, from whose union with the Holy Spirit (*Sophia*) spring the elements. The combinations of the productive and receptive agents are called *syzygies*, and of them there are seven. Bardesanes, who had deeply studied the Chaldean astrology, seems to have discussed at great length the influence of the stars on human action. He vindicated for man, what may, with some stretch of language, be termed a *transcendental* freedom. His followers were distinguished by the strange opinion they entertained with regard to the body of Christ, which they held to be only phenomenal, not real. Besides the notices of Bardesanes to be found in general works on Gnosticism,—as those of Beur, Matter, Lipsius, and Mansel,—the following may be consulted:—Hahn, *Bardesanes Gnosticus Syrorum primus hymnologus*, 1819; Hilgenfeld, *Bardesanes, der letzte Gnostiker*, 1864.

**BARDILLI, CHRISTOPH GOTTFRIED**, a German metaphysician, distinguished by his opposition to the system of Kant, was born at Blaubeuren in Würtemberg, in 1761, and died at Stuttgart in 1808. Of his numerous works the principal is his *Elements of Logic (Grundriss der ersten Logik*, Stuttgart, 1800). His system has had but little influence in Germany, the celebrated Reinhold being the only adherent of any importance. Yet in some respects his ideas opened the way for the later speculations of Schelling and Hegel. He dissented strongly from the Kantian distinction between matter and form of thought, and urged that philosophy should consider only thought in itself, pure thought, which is the ground or possibility of being. The fundamental principle of thought and criterion of certitude was, according to him, the law of identity; logical thinking was real thinking. The matter upon which thought operated was in itself indefinite and unformed, a mere *ἀσχηματιστος*, which was rendered definite or took determinate forms through the action upon it of thought. Bardilli, however, worked out his fundamental idea in an abstract, one-sided manner. Thought, as conceived by him, had no power of development in it, and ultimately reduced itself to a species of arithmetical computation. (See on his system the notices in Michelet, *Geschichte der letzten Systeme*, Bd. i., and Erdmann, *Versuch einer Geschichte d. neu. Phil.*, Bd. iii. pt. i.)

**BARDSEY** (*i. e.*, Bard's Island), or in Welsh **YNYN ENLLI**, the Island of the Current, is situated at the northern extremity of Cardigan Bay. It is  $2\frac{1}{2}$  miles long by 1 broad, with an area of about 370 acres, of which one-third is hilly. The island produces both barley and oats. On the S.E. side there is a harbour which admits vessels of 40 tons. On the north side are the ruins of St Mary's Abbey, said to have been founded by Cadfan in 516, which afforded refuge to great numbers of fugitives during the 7th century. The lighthouse has a fixed light 129 feet above high water, in lat.  $52^{\circ} 45' N.$ , long.  $4^{\circ} 47' W.$

**BARDWAN** (sometimes spelled *Bardwan*), a division or commissionership in India under the Lieutenant-Governor of Bengal, comprising the districts of Bardwan, Húglí with Howrah, Midnapur, Bánkurá or West Bardwan, and Bírhmú, lies between  $23^{\circ}$  and  $35^{\circ}$  N. lat. and between  $86^{\circ}$  and  $89^{\circ}$  E. long. It is bounded on the N. by the district of the Santál Parganá in the Bhágalpur division, and Murshidábád in the Rájsháhí division; on the E. by the Presidency districts of Nadiyá, and the 24 Parganá; on the S. by the Bay of Bengal, and on the W. by the native tributary state of Morbhánj, and the district of Mánbhúm in the Chhotá Nágpur division. In 1872 Bardwan division contained an area of 12,719 square miles, with a population of 7,286,957, inhabiting 25,842 towns and villages, and 1,468,791 houses; persons per square mile, 573; villages or townships per square mile, 2.03; houses per square mile, 115; persons per village, 282; and persons per house, 5. The census of 1872 classifies the population of the Bardwan division as follow:—Hindus—males, 3,051,967; females, 3,164,093; total, 6,216,060, or 85.3 per cent; Mahometans—males, 450,103; females, 479,288; total, 929,391, or 12.8 per cent; Christians—males, 2352; females, 2053; total, 4405, or .1 per cent; total—males, 3,572,108, or 49 per cent; females, 3,714,849, or 51 per cent; grand total, 7,286,957.

**BARDWAN**, an important district in the division of the same name, under the Lieutenant-Governor of Bengal, situated between  $23^{\circ} 53'$  and  $22^{\circ} 46'$  N. lat., and between  $88^{\circ} 39'$  and  $86^{\circ} 52'$  E. long. It is bounded on the N. by the districts of Bírhmú and Murshidábád, from which it is separated by the River Ajai; on the E. by the districts of Nadiyá and Húglí, the River Bhágirathi separating it from the former; on the S. by the districts of Húglí and Midnapur; and on the W. by the districts of Bánkurá and Mánbhúm. For fiscal purposes the Board of Revenue returns its area at 3150 square miles:—cultivated, 2810; cultivable, but not cultivated, 190; and uncultivable, 150. The census of 1872 gives the police area at 3523 square miles, with a population of 2,034,745 souls, inhabiting 5191 villages, and residing in 435,416 houses. Persons per square mile, 578; per village, 392; per house, 4.7. Hindus number 1,679,363, or 82.5 per cent; Mahometans, 348,024, or 17.1 per cent; Christians, 890, or 1 per cent; and persons of unspecified religion, 6468, or .3 per cent.

Bardwan is a flat plain, and its scenery is uninteresting. Chief rivers—the Bhágirathi, Dámodar, Ajai, Bánká, Kunur, and Kharí, of which only the Bhágirathi is navigable by country cargo boats throughout the year. Agricultural products—paddy, indigo, pulses, oil-seeds, sugar-cane, potatoes, tobacco, wheat, onions, garlic, pumpkin, melons, cucumbers, and vegetables of various kinds. Bardwan district is one of the best cultivated in Lower Bengal. Minerals—iron, copper, lime and sandstone, and above all, coal. The greater portion of the coal-bearing rocks, known as the Dámodar or Rániganj field, is enclosed between the Rivers Dámodar and Ajai, and lies between  $23^{\circ} 35'$  and  $23^{\circ} 45'$  N. lat., and  $86^{\circ} 40'$  and  $87^{\circ} 15'$  E. long., at a distance of from about 120 to 160 miles north-west from Calcutta. The beds are composed of coarse and fine sandstones and felspathic coal-seams, the latter being frequently continuous over considerable areas. Those known as the Lower Dámodars are coarse conglomerates, with white sandstones and numerous coal-seams of very irregular character. The working of the Rániganj coal (which at present, 1874, is included within the Bardwan district) dates from 1774, when a company was formed by several English gentlemen for the purpose of mining the collieries; and in the following year 91 tons of Bardwan coal were despatched to Calcutta. In 1860, 49 collieries were worked, chiefly conducted with European capital, and yielded a total out-turn of 318,300 tons. In 1868 the out-turn of the whole coal-field exceeded 500,000 tons. There are now 44 coal-mines at work within the Bardwan district, of which 19 mines turn out more than 10,000 tons of coal apiece per annum. In the larger and better mines coal is raised by steam from pits and galleries. In the smaller mines or workings coal is raised by hand-labour from open quarries. In the Rániganj coal-field 61 steam engines, with an aggregate of 867 horse-power, are at work. Only one seam (or set of seams) of a less thickness than  $8\frac{1}{2}$  feet is

worked, and the average thickness of the seams at the Rániganj mines is about 15 or 16 feet. The pits are mostly shallow, very few being more than 150 feet deep. The Bengal Coal Company, with its mines at Rániganj and westwards, is alone able to raise more than 200,000 tons of coal annually. Silk and cotton cloth, brass utensils, silver and gold ornaments, and indigo, are the principal manufactures of the district. Three indigo factories in Bardwán are conducted with European capital. Articles of trade consist of rice, tobacco, pulses, wheat, oil-seeds, jute, sugar, salt, English and country made cloths, cotton, molasses, timber, and coal. In 1790 the total revenue of the Bardwán district amounted to £508,098, in 1820 to £458,321, and in 1870 (after transfers of a large part of its area to adjoining districts) to £388,778. The expenditure in 1797 amounted to £11,218, in 1820 to £17,338, and in 1870 to £63,485. The land tax is the principal source of revenue, which amounted in 1790 to £503,272, in 1850 (from a reduced area) to £309,812, and in 1870 to £305,806. For the protection of person and property Government maintained in 1871 a regular constabulary force 682 strong, at a total cost of £11,622 a year, besides 11,052 men of the village watch possessing service lands or paid by the villagers. Bardwán contained 989 schools in 1871-72, attended by 21,926 pupils, and costing £4328 annually to the state. For administrative purposes the district is divided into six magisterial subdivisions—Bardwán, Káiná, Kátwá, Bud-bud, Rániganj, and Jahánábád, with 22 police circles. Exclusive of the Bardwán city described below, there are seven towns in the district containing a population of more than 5000 souls. They are also municipalities, and are as follows:—1. Káiná—population: Hindus, 22,463; Mahometans, 8567; Christians, 33; others, 1278; total, 27,336; municipal income in 1872, £1185; expenditure, £980; rate of taxation, 10½d. per head. 2. Syámabádr—population: Hindus, 19,341; Mahometans, 294; total, 19,635; municipal income, £276; expenditure, £224; rate of taxation, 3½d. per head. 3. Rániganj—population: Hindus, 17,927; Mahometans, 1478; Christians, 178; total, 19,578; municipal income, £271,12a; expenditure, £271,12a; rate of taxation, 8d. per head. 4. Jahánábád—Hindus, 10,222; Mahometans, 8187; total, 18,409; municipal income, £238,18a; expenditure, £250,14a; rate of taxation per head, 4½d. 5. Báli—population: Hindus, 8150; Mahometans, 869; total, 8819; municipal income, £178,4a; expenditure, £214,4a; rate of municipal taxation, 4½d. per head. 6. Kátwá—population: Hindus, 6817; Mahometans, 1181; Christians, 15; total, 7983; municipal income, £518,14a; expenditure, £518,14a; rate of taxation, 1a. 3½d. per head. 7. Dainhát—population: Hindus, 7389; Mahometans, 173; total, 7562; municipal income, £398,8a; expenditure, £386,8a; rate of taxation, 1a. 0½d. per head. The East Indian Railway and the Grand Trunk road leading to the North-Western Provinces pass through the district, which has also fifteen other roads communicating with the neighbouring districts. The climate of Bardwán was considered a few years back to be the healthiest in Bengal. But an epidemic fever broke out about 1867, and is still (1874) raging in the district. It causes havoc and depopulation among the cultivating classes. The Mahárájá of Bardwán, one of the largest landholders in Bengal, has an income estimated at £400,000 to £500,000 sterling a year. Bardwán district was acquired by the East India Company under the treaty with Nawáb Mir Kásim in 1760, and confirmed by the Emperor Sháh Alam in 1766. The land revenue was fixed in perpetuity with the zamindárs in 1793.

**BARDWÁN**, the principal town of the district of the same name, situated on the route from Calcutta to Benares, and a station on the East Indian Railway, lies in 23° 14' 15" N. lat., and 87° 53' 57" E. long. Jacquemont formerly described Bardwán town "as consisting of an assemblage of crowded suburbs, of wretched huts, with walls of mud, and covered with thatch, having no temples of striking aspect, and few handsome houses." At the present time Bardwán is a well-built, busy town, with commodious streets, dotted with large tanks, and surrounded by luxuriant gardens. The Mahárájá's palaces are handsome buildings, furnished in the English style, with elegant mirrors and nick-nacks from Paris, and some tolerable oil paintings. Bardwán forms the headquarters of the civil authorities of the division and district, consisting of the commissioner, the judge, magistrate, and collector, and their European and native assistants. In 1814 the town contained a population estimated at 53,927 souls; and in 1872, 32,321. Details of population in 1872:—Hindus, 22,013; Mahometans, 9927; Christians, 223; persons of unspecified religion, 158; total, 32,321. Municipal income in 1871, £5450; expenditure, £5450; rate of

taxation, 3a. 4½d. per head. In 1625 Bardwán was besieged by a rebel chief of the Great Mughl. The city soon fell into the hands of the besiegers, the Rájá was slain in battle outside the walls, and the ladies of his family committed suicide, to avoid falling into the hands of the conquerors. The present Mahárájá is a well-educated, liberal-minded man. He maintains a great public school in the town at his own cost, and is ever forward with help in time of distress or famine, as in 1866 and 1874.

**BARÈGES**, a small town situated between two mountain chains in the department of Hautes Pyrénées in France, about 25 miles from Bagnères de Bigorre. It is celebrated for its warm sulphurous springs, first brought into notice by the visit of Madame du Maintenon in 1676, the temperature of which varies from 88° to 111° Fahr. The benefit of the waters is granted to the army at the expense of the Government, which erected a bath-house in 1864. During the winter the town is so exposed to avalanches that only a few of the residents remain. The town gives its name to a silk-fabric (barège) which is principally manufactured in Bagnères de Bigorre.

**BARELI**, or **BARELLY**, a district of British India in the Rohilkhand division, under the jurisdiction of the Lt.-Governor of the North-Western Provinces, situated between 28° 2' and 29° 2' N. lat., and 79° 2' 30" and 80° 13' 15" E. long. It is bounded on the N. by Kumson district and the independent state of Nepal; on the E. by a portion of the district of Sháhjahánpur, and the district of Lakhimpur in Oudh; on the S. by the districts of Budson and Sháhjahánpur; and on the W. by the native state of Rampur and Budson. Bareli is a level country, watered by many streams, the general slope being towards the south. The soil is fertile and highly cultivated, groves of noble trees abound, and the villages have a neat, prosperous look. A tract of forest jungle, called the *Tardá*, stretches along the extreme north of the district, and teems with large game, such as tigers, bears, deer, wild pigs, &c.

The River Sardá or Ghagra forms the eastern boundary of the district, and is the principal stream. Next in importance is the Rámanganj, which receives as its tributaries most of the hill torrents of the Kumson mountains; the principal ones being the East Bahgúl, Nakatiyá, Deuraniyá, Sankhá, Sidhá, Dujaurá, Kichaha, West Bahgúl, Bhakrá, Dhakrá, and Dhúrá. The Deohá is another great drainage artery, and receives many minor streams. The Gomati or Gumti also passes through the district. Bareli district has an area of 2976·70 square miles, of which 1845·28 square miles are under cultivation; 727·66 square miles are cultivable, but not actually under cultivation; 25·16 square miles are held revenue free; and 378·60 square miles are returned as uncultivable waste.

The census of 1872 takes the area at 2982 square miles, and returns the population at 1,507,139 souls, inhabiting 3548 villages or townships, and 296,441 houses; density of population per square mile, 505; villages or townships per square mile, 1·2; persons per village or township, 425; houses per square mile, 99; persons per house, 5. Of the total population, 1,197,583, or 79·5 per cent., are Hindus; 308,682, or 20·5 per cent., Mahometans; and 536 Christians, or others of unspecified religion. The Mahometans are chiefly the descendants of Yusufzái Afgháns, called the Rohillá Patháns, who settled in the country about the year 1720. The Rohillás were formerly the ruling race of the tract of country called Rohilkhand, and are men of a taller stature, a fairer complexion, and a more arrogant air than the general inhabitants of the district. Bishop Heber has described them as follows:—"The country is burdened with a crowd of lazy, profligate, self-called sawárs (cavaliers), who, though many of them are not worth a rupee, conceive it derogatory to their gentility and Pathán blood to apply themselves to any honest industry, and obtain for the most part a precarious livelihood by sponging on the industrious tradesmen and far-



mers, on whom they levy a sort of blackmail, or as hangers on to the few wealthy and noble families yet remaining in the province. These men have no visible means of maintenance, and no visible occupation except that of lounging up and down with their swords and shields, like the ancient Highlanders, whom in many respects they much resemble." The Rohillas, after fifty years' precarious independence, were subjugated in 1774 by the confederacy of British troops with the Nawáb of Oudh's army, which formed so serious a charge against Warren Hastings. Their territory was in that year annexed to Oudh. In 1801 the Nawáb of Oudh ceded it to the Company in commutation of the subsidy money. During the Sepoy Mutiny of 1857 the Rohillas took a very active part against the English, but since then they have been disarmed. Both before and after that year, however, the Bareil Mahometans have distinguished themselves by fanatical tumults against the Hindus.

The inhabitants of the district are for the most part poor, but their condition has improved under English rule. Sugar and rice, of which large quantities are exported, form the principal agricultural products of the district. Pilibhit formed an independent district till its incorporation with Bareil in 1842; its rise is celebrated all over the N.W. Provinces. Other agricultural products—wheat, barley, cotton, tobacco, maize, millet, pulses, and fruit. The jungle tract of the district produces fine timber, in which a large trade is carried on. The total revenue of the district for 1870-71 amounted to £246,419, and the civil expenditure to £80,978. By far the greater part of the revenue is derived from the land; the new settlement for thirty years was concluded in 1872. Four towns contain a population of upwards of 5000 souls:—1. Bareil—area, 1280 acres, noticed below. 2. Pilibhit—area, 483 acres; population, 29,840; municipal revenue (1872), £3291, 6s.; expenditure, £2698, 2s.; rate of taxation, 2s. 2½d. per head. 3. Bindápur—area, 148 acres; population, 9250; municipal revenue, £282, 8s.; expenditure, £348, 18s.; rate of taxation, 7½d. per head. 4. Anwáh—area, 128 acres; population, 11,163; municipal revenue, £188, 2s. 6½d.; expenditure, £234, 15s. 10d.; rate of taxation, 4d. per head. Other minor towns: Faridpur, population, 4940; Sarauli, 4585; Nawábganj, 4418. There are 19 other towns with a population of above 2000. Bareil shows a heavy criminal return, and the police do not appear to be successful in grappling with crime. The regular police consists of a force of 4218 men. In 1872 there were 518 schools in the district, attended by 9265 pupils, besides those attending the university college in the town of Bareil.

**BAREIL** [*Bareilly*], the principal place in the district of the same name, situated on the left bank of the Jui, a tributary of the Western Rámgar, in N. lat. 28° 23', E. long. 79° 28'. It is a large town, with a brick and lucrative commerce, and manufactures consisting principally of house furnitures, such as chairs, tables, &c. Mr Thornton says, that "besides the hands engaged in this branch of handicraft, there are cotton weavers, dressers, and twisters, manufacturers of muslins, and also of silks and brocades, dyers and colour-makers, linen and cloth-plaiters, gold and silver lace-makers, jewellers, goldsmiths, and silversmiths, blacksmiths, coppersmiths, and tinmen, cutlers, armourers, seal-makers and engravers, turners, saddlers, tailors, &c., &c." In 1872 Bareil town contained a population of 102,982, of whom 59,036 were Hindus, 43,463 Mahometans, and 483 of unspecified religion. In 1872 the municipal revenue of the town amounted to £6602, 8s.; expenditure, £7217, 12s.; rate of municipal taxation, 1s. 3½d per head of the population. The municipal revenue is derived from *octroi* duties levied on articles of food brought for sale into the town. The principal institution in the town is the Bareil college, intended as a seat of upper class learning for the surrounding districts of the N.W. Provinces. It is conducted by a staff of efficient professors from England, and its course includes the subjects for degrees in the Calcutta University. In 1872-73 it was attended by 310 pupils. The cost of the college department and upperschool amounted to £5836, of which Government contributed £5335.

**BARÈRE DE VIEUZAC, BERTRAND**, one of the most notorious members of the French National Convention,

was born at Tarbes in Gascony, September 10, 1755. He was brought up to the profession of the law, and was admitted advocate to the parliament of Toulouse. He wrote several trivial pieces, panegyrics of Louis XVI., Montesquieu, J. J. Rousseau, and others, which obtained prizes from provincial academies, and a dissertation on a Latin inscription which procured him membership of the Academy of Floral Games of Toulouse. Such was the smooth beginning of a career which ultimately became unparalleled for meanness, cowardice, lying, and atrocious cruelty. At the age of thirty he married. Four years later, in 1789, he was elected deputy by his own province to the States-general, which met in May. He had made his first visit to Paris in the preceding year. His personal appearance, his manners, social qualities, and liberal opinions, gave him a good standing among the multitude of provincial wise-heads then thronging into Paris, eager to be the saviours of France, or at least of themselves. He took his place at first with the monarchical party; and his glib pen found occupation in the preparation of various reports, and in editing a journal, the *Point du Jour*, containing reports of the debates of the National Assembly. For a time he formed a connection with the House of Orleans, passing over soon to the republican party. Barèru appears to have been wholly free from the restraints of conscience or any guiding principle; his conduct was regulated only by the determination to be on the side of the strongest. After the close of the National Assembly he was nominated one of the judges of the newly-instituted Court of Cassation. In 1792 he was elected deputy to the National Convention for the department of the Hautes Pyrénées. At first he took part with the Girondists; but on the trial of the king he voted, with the Mountain, for the king's death "*sans appel et sans surseis*." He closed his speech with a sentence which became memorable, "*L'arbre de la liberté ne saurait croître s'il n'était arrosé du sang du roi*." As the Mountain became the strongest party Barère advanced with it, unscrupulously carrying out its extremest projects, and playing a prominent part in the Reign of Terror. The light-heartedness with which he acted in these awful scenes, the fluency and flippancy of his speeches and reports, procured him the title of the "Anacreon of the Guillotine." He supported Robespierre in his atrocious measure against the Girondists, crawled like a slave at the feet of the "incorruptible" Maximilian till the day of his fall, and then advocated his execution without a hearing. It was Barère who had proposed the decree that no quarter should be given to any English or Hanoverian soldier, which was unanimously adopted. This procured him admission by acclamation to the Jacobin Club, from which he had been previously excluded. The decree, however, remained a dead letter. A few months after the fall of the Convention, proceedings were taken against Barère and his colleagues of the Terror, Collot d'Herbois and Billaud-Varennes, and he was sent to the Isle of Oléron. He was removed to Saintes, and thence escaped to Bordeaux, where he lay in concealment for several years. In 1795 he was elected member of the Council of Five Hundred, but was not allowed to take his seat. When Napoleon Bonaparte was First Consul he was anxious to employ Barère, but Barère refused the overture. It was only for a while. The witting of the Terror became the hireling and the spy of the new tyranny. On the fall of Napoleon, Barère played the part of royalist, but on the final restoration of the Bourbons in 1815 he was banished for life from France, and then withdrew into Belgium and temporary oblivion. After the Revolution of July 1830 he reappeared in France, was reduced by a series of lawsuits to extreme indigence, accepted a small pension assigned him by Louis Philippe (on whom he had heaped

abuse and railing), and died, the last survivor of the Committee of Public Safety, January 15, 1841. Two years after his death appeared *Mémoires de Bertrand Barère*, edited by Hippolyte Carnot and David of Angers. (See Macaulay's article in the *Edinburgh Review*, vol. lxxix, in which the character and career of Barère<sup>1</sup> are discussed with characteristic emphasis and severity.)

BARETTI, GIUSEPPE, an Italian critic of some distinction, was born at Turin in 1716. He was intended by his father for the profession of law, but at the age of sixteen fled from Turin and went to Guastalla, where he was for some time employed in a mercantile house. His leisure hours he devoted to literature and criticism, in which he became expert. For many years he led a wandering life, supporting himself chiefly by his writings. At length he arrived in London, where he remained for a considerable time. He obtained an appointment as secretary to the Royal Academy of Painting, and became acquainted with Johnson, Garrick, and others of that society. He was a frequent visitor at the Thrales'; and his name occurs repeatedly in Boswell's *Life*. In 1769 he was tried for murder, having had the misfortune to inflict a mortal wound with his fruit knife on a man who had assaulted him in the street. Johnson among others gave evidence in his favour at the trial, which resulted in Baret's acquittal. He died in May 1789. His first work of any importance was the *Italian Library*, London, 1757, a useful catalogue of the lives and works of many Italian authors. The *Letters Familiari*, giving an account of his travels through Spain, Portugal, and France during the years 1761-1765, were well received, and when afterwards published in English, 4 vols., 1770, were highly commended by Johnson. While in Italy on his travels Baret set on foot a journal of literary criticism, to which he gave the title of *Frustra Letteraria*, the literary scourge. It was published under considerable difficulties and was soon discontinued. The criticisms on contemporary writers were sometimes just, but are frequently disfigured by undue vehemence and coarseness. Among his other numerous works may be mentioned a useful *Dictionary and Grammar of the Italian Language*, and a dissertation on Shakespeare and Voltaire.

BARFLEUR, called formerly Barbeflot, and in the Latin chronicles *Barbatius Fluctus*, an ancient town of Normandy, in France, now in the department of Manche, 15 miles E. of Cherbourg. It was at one time the seat of an active trade across the Channel, but was ruined and had its harbour filled up by the English in 1346. Cape Barfleur has a lighthouse 271 feet above the sea, in long. 1° 16' W., lat. 49° 40' N.

BARHAM, RICHARD HARRIS, a celebrated humourist, better known by his *nom de plume* of THOMAS INGOLDSBY, was born at Canterbury, December 6, 1788. At seven years of age he lost his father, who left him a small estate, part of which was the manor of Tappington, so frequently mentioned in the *Legends*. At nine he was sent to St Paul's school, but his studies were interrupted by an

<sup>1</sup> Summed up thus:—"Our opinion then is this, that Barère approached nearer than any person mentioned in history or fiction, whether man or devil, to the idea of consummate and universal depravity. In him the qualities which are the proper objects of hatred, and the qualities which are the proper objects of contempt, preserve an exquisite and absolute harmony. In almost every particular sort of wickedness he has had rivals. His sensuality was immoderate; but this was a failing common to him with many great and amiable men. There have been many men as cowardly as he, some as cruel, a few as mean, a few as impudent. There may also have been as great liars, though we never met with them or read of them. But when we put everything together, sensuality, poltroonery, baseness, affrontery, mendacity, barbarity, the result is something which in a novel we should condemn as caricature, and to which, we venture to say, no parallel can be found in history."

accident which shattered his arm and partially crippled it for life. Thus deprived of the power of bodily activity, he became a great reader and diligent student. In 1807 he entered Brasenose College, Oxford, intending at first to study for the profession of the law. Circumstances, however, induced him to change his mind and to enter the church. The choice seems surprising, for he had from childhood displayed that propensity to fun in the form of parody and punning which afterwards made him a reputation. In 1813 he was ordained and took a country curacy; he married in the following year, and in 1821 removed to London on obtaining the appointment of minor canon of St Paul's Cathedral. Three years later he became one of the priests in ordinary of his Majesty's chapel royal. In 1826 he first contributed to *Blackwood's Magazine*; and on the establishment of *Bentley's Miscellany* in 1837 he began to furnish the series of grotesque metrical tales known as *The Ingoldsby Legends*. These became very popular, were published in a collected form, and have since passed through numerous editions. In variety and whimsicality of rhymes these verses have hardly a rival since the days of *Hudibras*. But beneath this obvious popular quality there lies a store of solid antiquarian learning, the fruit of patient enthusiastic research by the light of the midnight lamp, in out-of-the-way old books, which few readers who laugh over his pages detect. If it were of any avail we might regret that a more active faculty of veneration did not keep him from writing some objectionable passages of the *Legends*. His life was grave, dignified, and highly honoured. His sound judgment and his kind heart made him the trusted counsellor, the valued friend, and the frequent peacemaker; and he was intolerant of all that was mean, and base, and false. In politics he was a Tory of the old school; yet he was the life-long friend of the liberal Sydney Smith, whom in many respects he singularly resembled. Theodore Hook was one of his most intimate friends. Mr Barham was a contributor to the *Edinburgh Review* and the *Literary Gazette*; published a novel in 3 vols., entitled *My Cousin Nicholas*; and, strange to tell, wrote nearly a third of the articles in Gorton's *Biographical Dictionary*. His life was not without such changes and sorrows as make men grave. He had nine children, and six of them died in his lifetime. But he retained vigour and freshness of heart and mind to the last, and his latest verses show no signs of decay. He died in London after a long, painful illness, June 17, 1845, leaving his beloved wife, two daughters, and a son, surviving him. A short memoir, by his son, was prefixed to a new edition of *Ingoldsby* in 1847, and a fuller *Life and Letters* was published in 2 vols. in 1870.

BARÌ, TERRA DI, a province of Italy, in the district of Apulia, bounded on the N. by the Adriatic, E. and S.E. by the province of Otranto, S.W. by Basilicata, and W. by Capitanata. It has an area of 1762 geographical square miles, and is divided into the three districts of Bari, Barletta, and Altamura. Except in the S. and S.W., where branches of the Apennines occur, the surface is generally level. The soil is for the most part calcareous, with a rich covering of loam. The climate is oppressively hot in summer, but very pleasant during the rest of the year. The only considerable river is the Ofanto, or *Aufidus*; but, in spite of the lack of irrigation, the province is among the best cultivated in the kingdom, producing abundance of grain, flax, tobacco, cotton, wine, oil, almonds, liquorice, &c. Swine, asses, goats, and sheep with a very fine wool, are numerous; and the salt and nitre works form important branches of industry. Among the more important towns besides the capital are Barletta, Trani, Bisceglie, Molfetta, Monopoli, and Fasano on the coast, and Andria, Ruvo, Nola, Bitonto, and Conversano somewhat inland.

The population, which is densest along the coast, was 604,540 in 1871.

**BARI**, the ancient *Barium*, capital of the above province and seat of an archbishop, is situated on a tongue of land projecting into the Adriatic, in lat. 41° 7' N., and long. 16° 53' E. It is defended by various fortifications, among which the most important is the citadel, which is about a mile in circumference, and dates from the Norman possession. The general character of the older part of the town is gloomy and irregular, but the newer portion has spacious streets, with handsome buildings. The priory of St Nicolo, built by Robert Guiscard in 1087 to hold the relics of the saint, which had been brought from Myra in Lycia, is interesting for its beautiful crypt and the tombs of Robert of Bari and Bona Sforza of Poland. The festival of St Nicholas, on the 8th of May, is still attended by thousands; and his body is believed by the superstitious to supply the *Manna di Bari*. The cathedral of St Sabino, a fine Gothic structure, was barbarously bestuiced and transformed by Archbishop Gaeta in 1745. Among the other buildings of importance are the palace of the "Intendente," the theatre (a large modern erection), the Lyceum, a college for the education of the nobility, and an "Athenæum." The commercial importance of Bari has been for some time on the increase; and its harbour, augmented by the building of two moles in 1855, has more recently received a still greater extension, while excellent anchorage is also afforded by its roads. The inhabitants are skilful seamen, and carry on a large traffic in their own ships with different parts of the Adriatic. The exports, which consist chiefly of olive oil, wine, mustard seed, cream of tartar, grain, and almonds and other fruits, were valued in 1872 at £642,818, while the imports of the same year amounted to £249,081. The railway to Brindisi was opened in 1865, and another line has since been extended to Taranto. *Barium*, according to the evidence of its coins, was a place of importance in the 3d century B.C., and had a decided Greek element in its culture; but it never acquired any great influence in the old Roman world, and all allusions to it in the classical authors are of an incidental description. After the fall of the Western empire it was subject in turn to the Greek emperors, to the dukes of Benevento, and to the Saracen invaders. From the last it was delivered in 971 by Louis II., and again in 1002 by the Venetians, who left their Lion of St Mark as an emblem to the city. Not long after it was raised to the rank of capital of Apulia by the Greek emperors, who were soon (1040) compelled to acknowledge it as a free principality under Argyrus. After a four years' siege it was taken in 1070 by the Normans, who lost it in 1137 to Lothaire, but recovered it a few years later. In 1156 it was razed by William the Bad, and has several times suffered a similar fate. In the 14th century Bari became a duchy, which continued to exist till 1558, when it was bequeathed by Bona Sforza to Philip II. of Spain.

See Bestillo, *Historia de Bari*, Napoli, 1697; Lombardi, *Compendio cronologico delle vite degli arcivescovi Baroni*, Napoli, 1697.

**BARKING**, a town of England, county of Essex, 7 miles E.N.E. of London, on the River Roding, not far from the Thames. It was celebrated for its nunnery, one of the oldest and richest in England, founded about 670 by Erkenwald, bishop of London, and restored in 970 by King Edgar, about a hundred years after its destruction by the Danes. The abbess was a baroness *ex officio*, and the revenue at the dissolution of the monasteries was £1084. The church of St Margaret is an ancient edifice of considerable beauty, with some curious monuments; and the ancient market-house, no longer used, and an embattled gateway, are also worthy of mention. The various dissenting denominations have places of worship in the town.

Population in 1871, 5766, principally engaged in the river traffic and in the cultivation of vegetables for the London market. There is no longer much attention paid to the fishery, but various industries have been introduced.

**BARLAAM AND JOSAPHAT**, Saints. These two saints appear in both the Greek and the Roman Martyrology, in the former under 26th August, in the latter under 27th November. Their story is in the highest degree worthy of note, because it is, in fact, a Christianized version of the Indian legendary history of the Buddha, Sakya Muni.

The remarkable parallel between Buddhistic ritual, costume, and discipline, and those which especially claim the title of Catholic in the Christian church, has often been recognized, even by the most faithful sons of Rome;<sup>1</sup> and though the parallel has perhaps never been elaborated as it might be, some of its more salient points are familiar. Still, many readers may be unaware that Sakya Muni himself, or, as he was by birth, Siddharta, the son of Suddodhana, prince of Kapilavastu (in the north of modern Oudh), has found his way into the Roman calendar as a saint of the church.

The Christian story first appears in Greek among the works of St John of Damascus, an eminent divine, and an opponent of the Emperor Leo the Isaurian in the Iconoclastic movement, who flourished in the early part of the 8th century, and who, before he adopted the monastic life and devoted himself to theology, had held high office at the court of the caliph Abu Jafar Almansur, as his father Sergius is said to have done before him.<sup>2</sup>

The outline of the Greek story is as follows:—St Thomas had converted the people of India, and after the eremitic life originated in Egypt, many Indians adopted it. But a powerful pagan king arose who hated and persecuted the Christians, especially the ascetics. After this king, Abenner by name, had long been childless, a boy greatly desired, and matchless in beauty, was born to him, and received the name of Josphat. The king, in his joy, summons astrologers to predict the child's destiny. They foretell glory and prosperity beyond those of all his predecessors. One sage, most learned of all, assents, but intimates that the scene of this glory will be, not the paternal kingdom, but another infinitely more exalted, and that the child will adopt the faith which his father persecutes.

The boy shows a thoughtful and devout turn. King Abenner, troubled by this and by the remembrance of the prediction, selects a secluded city, in which he causes a splendid palace to be built, where his son should abide, attended only by tutors and servants in the flower of youth and health. No stranger was to have access, and the boy was to be cognizant of none of the sorrows of humanity, such as poverty, disease, old age, or death, but only of what was pleasant, so that he should have no inducement to think of the future life; nor was he ever to hear a word of Christ and his religion.

Prince Josphat grows up in this seclusion, acquires all kinds of knowledge, and exhibits singular endowments. At length, on his urgent prayer, the king reluctantly permits him to pass the limits of the palace, after having taken all precautions to keep painful objects out of sight. But through some neglect of orders, the prince one day encounters a leper and a blind man, and asks of his attendants with pain and astonishment what such a spectacle should mean. These, they tell him, are ill, to which man is liable. Shall all men have such ill? he asks. And in the end he returns home in deep depression. Another day he falls in with a decrepit old man, and, stricken with dismay at the sight, renews his questions, and hears for the first time of death. And in how many years, continues the prince, does this fate befall man? and must he expect death as inevitable? Is there no way of escape? No means of eschewing this wretched state of decay? The attendants reply as may be imagined; and Josphat goes home more pensive than ever, dwelling on the certainty of death, and on what shall be thereafter.

At this time Barlaam, an eremite of great sanctity and knowledge, dwelling in the wilderness of Sennaritis, divinely warned,

<sup>1</sup> It has been alleged that Père Huc, on returning to Europe, was astonished to find his celebrated journey to Lhasa in the *Index*, on the ground of such recognition. But this seems to be untrue.

<sup>2</sup> St John's authorship of the story has been disputed. Prof. Max Müller, in the paper quoted below, seems to dispose sufficiently of the objections. None of the old editions of St John's works contain the Greek of the story. This, Prof. Müller states, was first published in 1832 by Boissacade, in his *Analecra Græca*, vol. iv.

travels to India in the disguise of a merchant, and gains access to Prince Josphat, to whom he imparts the Christian doctrine and commends the monastic life. Suspicion arises and Barlaam departs. But all attempts to shake the prince's convictions fail. As a last resource the king sends for Theudas, a magician, who removes the prince's attendants and substitutes seductive girls; but all their blandishments are resisted through prayer. The king abandons these efforts and associates his son in the government. The prince uses his power to promote religion, and everything prospers in his hands. At last Abenner himself yields to the faith, and after some years of penitence dies. Josphat surrenders the kingdom to a friend called Barachias, and departs for the wilderness. After two years of painful search, and much buffeting by demons, he finds Barlaam. The latter dies, and Josphat survives as a hermit many years. King Barachias afterwards arrives, and transfers the bodies of the two saints to India, where they are the source of many miracles.

Now this story is, in all essentials and in many details, *mutatis mutandis*, the story of Buddha. For particulars we must refer to the papers of M. Müller and F. Liebrecht cited below; we can indicate but one example in the prominent episode of Sakya's youth, his education in a secluded palace, his encounter successively with a decrepit old man, with a man in mortal disease and poverty, with a dead body, and, lastly, with a religious recluse radiant with peace and dignity, and his consequent abandonment of his princely state for the ascetic life in the jungle. Some of the correspondences in the two stories are most minute, and Prof. Müller has pointed out that even the phraseology, in which some of the details of Josphat's history are described, almost literally renders the Sanskrit of the *Lalitā Vistara*.

We have given but the skeleton of the history of Barlaam and Josphat. It is filled out with episodes and apologues, several of which also have been traced to Buddhist sources. These stories no doubt promoted the vast mediæval popularity of the legend in both the Greek and the Latin Churches. Its first favour in the former seems to have been due to its embodiment in the *Lives of the Saints*, as compiled anew by Simeon the Metaphrast, a person of disputed age, but not of later date than 1150 A.D. Selections from his work, in which this legend takes the lead, continue to be issued in Romæ as works of popular edification.

At what time the two saints first found their place in the Roman martyrology we have not been able to ascertain, but their story figures at length in the *Speculum Historiale* of Vincent of Beauvais, and more briefly in the *Golden Legend* of Jacobus de Voragine, both of the 13th century. There is a church bearing the dedication *Dieo Josphat* in Palermo, and probably others in other Catholic cities.

The story continued for centuries to be one of the most popular works in Christendom. It was translated into most European tongues, including Bohemian, Polish, and Icelandic. A version in the last, executed by a Norwegian king, dates from 1204; in the East there were versions in (at least) Arabic, Ethiopic, Armenian, and Hebrew; whilst a translation into the Tagala language of the Philippines was printed at Manilla in 1712. The story was rendered into poems and miracle plays. Moreover, its episodes and apologues have furnished material to poets and story-writers of very diverse ages and characters, e.g., to Boccaccio, to Gower, to the compiler of the *Gesta Romanorum*, to Shakespeare himself, and to the late W. Adams, author of the *King's Messengers*.

The identity of the stories of Buddha and St Josphat was recognised by the historian of Portuguese India, Diogo de Couto, as may be seen in his history (Dea. v. liv. vi. cap. 5). In modern times it was first noticed (according to Prof. M. Müller) by M. Laboulaye, in the *Journal des Débats* (21-26 July, 1859); but it was more elaborately set forth by the learned Dr Felix Liebrecht a year later (*Jahrbuch für Roman. und Engl. Literatur*, ii. p. 314); and was treated with his usual grace by Prof. Müller himself in his lecture on the "Migration of Fables" (see *Contemp. Review* for July 1870, pp. 588 *seq.*) (H. Y.)

BARLETTA, the ancient *Bardulium*, called in the Middle Ages *Barolium*, a fortified seaport town of Italy, the seat

of an archbishop, in the province of Terra di Bari. It is 33 miles N.W. of Bari, in lat. 41° 19' 26" N., long. 16° 18' 10" E. The town is well built and handsome; the houses are large, and the streets wide and well paved. It has a fine Gothic cathedral (S. Maria Maggiore) with a lofty spire, a number of churches and convents, an orphan asylum, a college, a theatre, and a colossal statue, supposed by some to be of the Emperor Heraclius, but this is denied by other art critics. The harbour is formed by a mole, on which a lighthouse is erected, and it is commanded by the citadel. It is only capable of admitting small vessels, but the town has a considerable trade in grain, wine, oil, fruit, salt, &c. Barletta was once one of the strongest cities in Italy, and in the 13th and 14th centuries was a favourite residence of the kings of Naples. It was here that the first tournament in that part of Italy was held in 1259, and in 1503 a remarkable combat took place in the neighbourhood between two chosen bands of Italian and French knights, led by Colonna and Bayard respectively. Population, 28,813. (See Marullo, *Diss. stor. sopra il colosso di Barletta*, Naples, 1816.)

BARLEY (*Hordeum*), a most important genus of the cereal plants which belongs peculiarly to temperate regions. Four distinct species of barley, cultivated for the production of grain, are commonly enumerated,—1st, common or two-rowed barley, *Hordeum distichum*; 2d, Bere or Bigg, *H. vulgare*; 3d, six-rowed barley, *H. hexastichum*; and 4th, fan, spratt, or battledore barley, *H. seccitum*. Of these species, but chiefly of the first two, very many varieties are recognized by cultivators, and new kinds are constantly being introduced. Barley is the most hardy of all cereal grains, its limit of cultivation extending further north than any other; and, at the same time, it can be profitably cultivated in sub-tropical countries. The opinion of Pliny, that it is the most ancient aliment of mankind, appears to be well founded, for no less than three varieties have been found in the lake dwellings of Switzerland, in deposits belonging to the Stone Period. According to Professor Heer these varieties are the common two-rowed (*H. distichum*), the large six-rowed (*H. hexastichum densum*), and the small six-rowed (*H. hexastichum saxatum*). The last variety is both the most ancient and the most commonly found, and is the sacred barley of antiquity, ears of which are frequently represented plaited in the hair of the goddess Ceres, besides being figured on ancient coins. The cultivation of barley in ancient Egypt is indicated in Exod. ix. 31. Till within recent times barley formed an important source of food in northern countries, and barley cakes are still to some extent eaten. Owing, however, to its poverty in that form of nitrogenous compound called gluten, so abundant in wheat, barley-flour cannot be baked into vesiculated bread; still it is a highly nutritious substance, the salts it contains having a high proportion of phosphoric acid, and on it the Greeks trained their athletes. The following is the composition of barley-meal according to Von Bibra, omitting the salts:—

Water.....	15	per cent.
Nitrogenous compounds.....	12.981	"
Gum.....	6.744	"
Sugar.....	3.200	"
Starch.....	59.950	"
Fat.....	2.170	"

Barley is now chiefly cultivated for making, to prepare spirits and beer (see *БАРЛЕТТА*), but it is also largely employed in domestic cookery. For the latter purpose the hard, somewhat stinty grains are preferable, and they are prepared by grinding off the outer cuticle which forms "pot barley." When the attrition is carried farther, so that the grain is reduced to small round pellets, it is termed "pearl barley." Patent barley is either pot or pearl barley reduced to flour. Under the name *decoctum Hordei*, a pre

paration of barley is included in the British Pharmacopœia, which is of value as a demulcent and emollient drink in febrile and inflammatory disorders. For the cultivation of barley, see AGRICULTURE, vol. i. p. 358.

The following table shows the quantities and values of barley imported into the United Kingdom in 1873:—

	Cwts.	£
From Russia.....	1,119,094	408,344
„ Sweden.....	182,004	86,366
„ Denmark.....	850,011	425,856
„ Germany.....	1,188,787	572,640
„ France.....	1,970,958	966,740
„ Turkey.....	2,905,646	1,137,147
„ Wallachia and Moldavia.....	836,606	322,064
„ Egypt.....	16,510	6,105
„ Tripoli and Tunis.....	28,554	11,880
„ Algeria.....	110,384	42,546
„ Other countries.....	82,559	34,484
Total.....	9,241,063	4,018,572

BARLOW, JOEL, an American poet and politician, born in 1755 at Reading in Connecticut. In 1774, some years after his father's death, he was entered at Yale College, New Haven, where he soon began to manifest considerable taste for poetry and power of composition. A few small pieces published by him were received with some degree of public favour. During his vacations he had taken part with the colonists in several engagements against the British, and immediately after completing his course, he qualified himself for the church, and was appointed chaplain to a regiment. This post he held till the conclusion of peace between Britain and America, when he settled in the village of Hartford, and began to practise as a lawyer. He also conducted a newspaper, and about the same time published his best poem, the *Vision of Columbus*, a vigorous and spirited piece of writing. About the year 1788 he gave up his newspaper and his legal practice, and came to Europe as the agent for a land company. Having discovered that this company was merely a swindling concern, he severed his connection with it, but did not return to America. In London he became acquainted with some of the most advanced liberal thinkers, and published several political tracts of a decidedly revolutionary character. In 1793, after having been some time in France, he accompanied the Commission of the National Convention, which was sent to organize the newly-acquired territory in Savoy. During his residence in Paris he engaged in commercial transactions, by which he acquired considerable fortune and importance. In 1795 he was appointed American consul at Algiers, and efficiently discharged the duties of that office. In 1805 he returned to America and began to interest himself in the politics of his own country. A pamphlet of his, sketching a plan of national education, was received with great favour. In 1808 he published an enlarged edition of his great poem, under the title *Columbiad*. It was magnificently illustrated, but did not achieve the popularity of its predecessor. In 1811 he was appointed minister plenipotentiary to France, with the object mainly of negotiating a commercial treaty and of obtaining compensation for some American property that had been unjustly confiscated. To accomplish this he required a personal interview with Napoleon, and set out to meet the emperor, who was at Wilna. On his way he was attacked with inflammation of the lungs, and died at a Polish village near Cracow, on the 22d December 1812.

BARLOW, PERNA, an able writer on pure and applied mathematics, was born at Norwich in 1776, and died in 1862. He received a very ordinary education, but improved himself by his own exertions. In 1806 he was appointed mathematical master in the Woolwich Academy, and filled that post for forty-one years. In 1823 he was made a Fellow of the Royal Society, and two years later received

the Copley medal. He received many distinctions from British and foreign scientific societies. Mr Barlow's principal works are—*Elementary Investigation of the Theory of Numbers*, 1811; *New Mathematical and Philosophical Dictionary*, 1814; *Essay on Magnetic Attractions*, 1820. The investigations on magnetism led to the important practical discovery of a means of rectifying or compensating compass errors in ships. Besides compiling numerous useful tables, Mr Barlow contributed largely to the *Encyclopædia Metropolitana*. The most important of his articles are—“Theory of Numbers,” “Mechanics,” “Hydrodynamica,” “Pneumatics,” “Optics,” “Astronomy,” “Magnetism,” and “Electro-Magnetism,” along with the huge volume on “Manufactures.”

BARMECIDES, or descendants of Barmak, were a noble Persian family, who attained great power under the Abbaside caliphs. Barmak, the first of them, was a Ghebre, or Persian fire-worshipper, and is supposed to have been a native of the district of Khorassan. He was introduced to the caliph Abd-ul-Malik, and acquired great power under him. His family prospered, and his grandson, Yahya, was vizier to the caliph El-Mahdy, and tutor of the famous prince Haroun-al-Raschid, celebrated in the *Thousand and One Nights*. Yahya's sons occupied high offices, one of them, Ja'afar (the Giafar of the *Arabian Nights*), being vizier and constant companion of Haroun. The caliph, however, conceived suspicions against the Barmecides, and in 802 beheaded Ja'afar with great cruelty, condemned the whole family to prison, and confiscated their property. Oriental historians give a romantic and not improbable reason for the caliph's conduct towards his vizier. Ja'afar had been married to Haroun's favourite sister, Abbasah, on condition that he should never see his wife save in presence of the caliph. He neglected this injunction, and Abbasah bore a son, who was brought up secretly. The caliph became aware of this, and in his wrath punished Ja'afar and all his family. The use of the expression *Barmecides' Feast*, to denote an imaginary banquet, is drawn from one of the tales in the *Arabian Nights*, where an entertainment of merely imaginary viands is served up to a hungry man by one of the Barmecides.

BARMEN, a town of Rhenish Prussia, in the government of Dusseldorf and circle of Elberfeld, on the Bergisch-Märkisch railway. It is formed by the combination of a large number of separate villages, which stretch along the northern valley of the Wupper for a distance of six miles in almost perfect continuity with Elberfeld. The first of these to obtain a separate civic organization was Gemarke, which may thus be regarded as the nucleus of the whole. The rapid development of manufacturing activity, to which the town owes its origin, only dates from the beginning of the 18th century. It is the chief seat of ribbon-weaving in Germany, and manufactures thread, lace, buttons, braids, cotton, cloth, silk stuffs, steel wares, and plated goods. There are also numerous bleachfields, printfields, dyeworks,—famous for their Turkey-red,—soap-works, chemical-works, and potteries. A chamber of commerce and a commercial tribunal hold their sessions in the town, which also possesses an exchange, a music hall, a deaf and dumb asylum, numerous schools, and a variety of churches. The most of the inhabitants are Protestants of various sects. The Rhenish-Westphalian Missionary Society maintains a theological seminary in the town and possesses an ethnographical museum. Population, 74,449.

BARNABAS (בָּרְנָבָא) was the surname given by the apostles to Joseph, “a Levite, of the country of Cyprus,” who, though like Paul not of the twelve, was with him recognized among the number of the apostles. The name (ὁ υἱὸς παρακλήσεως), translated “son of consolation” in the authorized version (Acts iv. 36), would be better rendered

"son of exhortation" or "of prophecy." Barnabas is first mentioned in the Acts (iv. 36, 37) as having sold his land and laid the money at the apostles' feet. He next appears as introducing Paul after his conversion to the other apostles (Acts ix. 27), from which a previous acquaintance has been inferred. Subsequent notices record a year's residence along with Saul at Antioch, where they "taught much people" (xi. 22-26), a visit to Jerusalem with contributions for the poorer brethren there (xi. 27-30), the ordination of Saul and Barnabas for the work to which they were called by the Holy Ghost (xiii. 2, 3), and a missionary journey of the two apostles to Cyprus and various cities of Asia Minor (xiii. xiv.) When the dissension arose as to the necessity of circumcision, Paul and Barnabas were sent to Jerusalem by the church at Antioch to consult the "apostles and elders" on the question (xv. 1-4). Soon after their return to Antioch they resolved to undertake a second missionary journey; but a difference arose between them in regard to the determination of Barnabas to take his sister's son, John Mark, along with him. "The contention was so sharp between them" (xv. 39) that they separated, Barnabas and Mark going to Cyprus, while Paul and Silas went to Syria and Cilicia. No further account of the career of Barnabas is given in the New Testament, with the exception of one or two incidental allusions in St Paul's epistles (1 Cor. ix. 6; Gal. ii. 1, 9, 13). Later writings and traditions have attempted to supply what is wanting in the Scriptural narrative, but they contain no facts that can be accepted as historically certain. According to Clement of Alexandria, Barnabas was one of the seventy disciples. Various accounts of still later date allege that he studied under Gamaliel along with Saul, that he suffered martyrdom at Cyprus, and that his body was discovered in the reign of the Emperor Zeno. He is also said to have been the founder and first bishop of the church at Milan. The festival of St Barnabas is held on the 11th of June.

**BARNABAS, EPISTLE OF, and GOSPEL OF.** See APOSTOLIC FATHERS and GOSPELS.

**BARNARD CASTLE,** a market and manufacturing town and parish in the county of Durham, on the banks of the Tees, 246 miles from London. It consists of one main street, about a mile long, with a number of smaller ones branching off on each side. The principal building in the high street is the town-hall, an octagonal structure dating from 1747. St Mary's church, built in the 12th century, and restored in 1871, contains some curious monuments; but the building of chief interest is the castle, from which the town derives its name, and which is the principal scene of Scott's *Rokeby*. This was founded in 1132 by Bernard Baliol, an ancestor of the competitor with Bruce for the Scottish crown, and was reduced to a ruinous condition by the siege of 1569, when it was defended for Queen Elizabeth by Sir George Bowes of Streatlam. The remains still extend over a space of more than six acres. A remarkable building, known as the Bowes' Mansion and Museum, was in 1874 bequeathed to the town by a descendant of the gallant knight. It contains a valuable collection of works of art, and is one of the finest edifices of the kind in the kingdom. The principal manufactures of Barnard Castle are carpets, woollen cloth, and shoe-thread. The corn-market is one of the largest in the north of England. A line joining the North-Eastern and the London and North Western Railways passes immediately to the north of the town. In the neighbourhood are Rokeby, Egglestone Abbey, Baby Castle, and Lartington Hall. (See Sir Walter Scott's *Rokeby*, and Atkinson's *Handbook of Barnard Castle*, 1874.)

**BARNAUL,** a town of Asiatic Russia, in the government of Tomak, and capital of a circle to which it gives its name.

It is situated in a wide plain which is bounded by offshoots of the Altai Mountains, and is built on both sides of the Barnaulka River at its confluence with the Ob, in lat. 53° 20' N., and long. 83° 26' E. It is the capital of an extensive mining district, and the seat of a board of administration. Besides its numerous smelting-furnaces, it possesses glassworks, a bell-foundry, and a mint; and it has also a library, an observatory, established in 1841, a mining school, a museum with a rich collection of mineral and zoological specimens, and a theatre, in addition to the governor's residence, the barracks, and other buildings belonging to its civic organization. Barnaul was founded in 1730 by Akyntshies Demidoff (to whose memory a monument has been erected), was raised to the rank of a town in 1771, and became capital of the circle in 1822. Population, 12,927.

**BARNAVE, ANTOINE PIERRE JOSEPH MARIE,** one of the greatest orators and noblest actors and victims of the first French Revolution, was born at Grenoble in Dauphiny, October 23, 1761. He was of a Protestant family. His father was an advocate to the parliament of Grenoble, and his mother was a woman of high birth, superior ability, and noble character. He was at once thoughtful and passionate, studious and social, handsome in person and graceful in manners. He was brought up to the law, and at the age of twenty-two made himself favourably known by a discourse pronounced before the local parliament on the division of political powers. Dauphiny was one of the first of the provinces to feel the excitement of the coming revolution; and Barnave was foremost to give voice to the general feeling, in a pamphlet entitled *Esprit des Édits enregistres militairement le 20 Mai 1788*. He was immediately elected deputy, with his father, to the States of Dauphiny, and took a prominent part in their debates. A few months later he was transferred to a grander field of action. The States-general were convoked at Versailles for May 5, 1789, and Barnave was chosen deputy of the *Tiers Etat* for his native province. He soon made an impression on the Assembly, and became the friend of most of the leaders of the popular party. He took part in the conferences on the claims of the three orders, drew up the first address to the king, and supported the proposal of Sieyès that the Assembly should declare itself National. Though a passionate lover of liberty, he knew that excess is the ruin of liberty, and maintained the necessity for the individual and for the community of both freedom and restraint. He hoped to secure the freedom of France and her monarchy at the same time. But he was almost unawares borne away by the mighty currents of the time, and he took part in the attacks on the monarchy, on the clergy, on church property, and on the provincial parliaments. With the one exception of the mighty Mirabeau, Barnave was the most powerful orator of the Assembly. On several occasions he stood in opposition to Mirabeau. After the fall of the Bastille he wished to save the throne. He advocated the suspensive veto, the system of two chambers, and the establishment of trial by jury in civil causes. His conflict with Mirabeau on the question of assigning to the king the right to make peace or war was one of the most striking scenes in the Assembly. About this time, after a vehement debate, he fought a duel with Cazales, in which the latter was slightly wounded. About the close of October 1790 Barnave was called to the presidency of the Assembly. On the death of Mirabeau a few months later, Barnave paid a high tribute to his worth and public services, designating him the Shakespeare of oratory. On the arrest of the king and the royal family at Varennes, while attempting to escape from France, Barnave was one of the three appointed to conduct them back to Paris. On the journey he was deeply affected by the mournful fate of these

royal persons, and resolved to do what he could to alleviate their sufferings. In one of his most powerful speeches he maintained the inviolability of the king's person. His public career came to an end with the close of the Constituent Assembly, and he returned to Grenoble at the beginning of 1792. His sympathy and relations with the royal family, and his desire to check the downward progress of the Revolution, brought on him the suspicion and persecution of the more violent party. At the end of August 1792 he was arrested and imprisoned, and in November 1793 was transferred to Paris. The nobility of his character was proof against the assaults of suffering. "Better to suffer and to die," he said, "than lose one shade of my moral and political character." On November 28 he appeared before the Revolutionary Tribunal, in company with Dupont-Dutertre, and two days later they both perished by the guillotine.

**BARNES, ALBERT**, a theologian of America, specially distinguished as a Biblical expositor, was born at Rome in the state of New York, 1st December 1798, and died at Philadelphia 24th December 1870. In 1820 he graduated at Hamilton College, and in the same year commenced his studies for the ministry at Princeton Theological Seminary. Soon after taking licence he was called to the Presbyterian church in Morristown, New Jersey, from which he was transferred to the pastoral charge of the first Presbyterian church of Philadelphia in 1830. In 1867 he was compelled to resign owing to failing health. Barnes held a prominent place in the New School branch of the Presbyterians, to which he had adhered on the division of the denomination. He was an eloquent preacher, but his wide-spread reputation rests chiefly on his expository works, which have probably had a larger circulation both in Europe and America than any others of their class. Of the well-known *Notes on the New Testament* it is said that more than a million volumes had been issued at the time of their author's death. The *Notes on Job*, the *Psalms*, *Isaiah*, and *Daniel*, found scarcely less acceptance. Displaying little original critical power, their chief merit lies in the fact that they bring the results of the criticism of others within the reach of general readers. Barnes was the author of several other works of a practical and devotional kind.

**BARNES, JOSEPH**, an English scholar, born in 1654. In 1695 he was chosen queen's professor of Greek, a language which he wrote and spoke with the utmost facility. One of his first publications was a whimsical tract, entitled *Gerania*, or a *New Discovery of the Little Sort of People called Pygmies*. Among his other works are a *Life of Edward III.*, in which he introduces his hero making long and elaborate speeches; *Sacred Poems*; the *Life of Oliver Cromwell the Tyrant*; some dramatic pieces; a poetical paraphrase on the history of *Esther*, in Greek verse, with a Latin translation, &c. He also published editions of *Euripides*, *Anacreon*, and Homer's *Iliad* and *Odyssey*, with notes and a Latin translation. He died in 1712.

**BARNET**, or **CHIPPING BARNET**, a market-town in the county of Hertford, 11 miles from London, on the great northern road. Near it, in 1471, was fought the decisive battle between the houses of York and Lancaster, in which the great earl of Warwick fell. The parish church dates from the 15th century, and the free school was founded by Elizabeth in 1573. The market, held on Monday, is large; and there are great cattle fairs. In the neighbourhood is the village of East Barnet, with a very ancient church. Population of parish in 1871, 3375.

**BARNEVELDT, JAN VAN OLDEF**, Grand Pensionary of Holland, who played a great part and rendered the most signal services to his country in the long conflict with

Philip II. of Spain, was born in 1547. He was a native of Amersfoort in the province of Utrecht, and could boast of a long line of noble ancestors. Endowed with superior abilities, he was educated for the profession of the law, and commenced practice as an advocate at the Hague in 1569. He sympathized deeply with his countrymen in their resolution to throw off the hated yoke of Spain, and served as a volunteer at the sieges of Haarlem and Leyden. In 1575 he married; and in the following year he was appointed to the honourable post of counsellor and chief-pensionary of Rotterdam. In 1585, when, in consequence of the assassination of the sagacious and resolute leader of the Dutch, and the general success of the Spaniards under the Prince of Parma, the cause of the patriots seemed almost hopeless, Barneveldt was chosen head of an embassy to Queen Elizabeth, to ask for her assistance and to offer her the sovereignty of the United Provinces. The queen agreed to give aid both in money and in men, but refused to accept the sovereignty. An expedition was sent under the command of Dudley, earl of Leicester, on whom the Dutch conferred supreme and absolute authority. Barneveldt was then raised to the high office of advocate-general of Holland and West Friesland. Dissatisfied and indignant at Leicester's incompetence, arrogance, and mismanagement, he endeavoured to limit his powers. For this purpose he succeeded in persuading the States to appoint Maurice of Nassau, the young son of the late Prince of Orange, stadtholder and captain-general of Holland and Zealand, thus contributing to place in the highest position the man who was afterwards to become his great antagonist. Leicester was recalled at the close of 1586. In the course of a few years Barneveldt, by his prudence and energy in administration, succeeded in restoring order and materially improving the financial affairs of the States. He proposed to resign in 1592, but at the urgent entreaty of the States retained his post. In 1598 he was sent on an embassy to Henry IV. of France, the object of which was to strengthen and maintain the friendship of France and the United Provinces. In 1603, on the accession of James I. to the throne, Barneveldt was again sent to England as head of an embassy, and in conjunction with the French ambassador, M. de Rosny, afterwards duke of Sully, negotiated an arrangement for further assistance against the Spaniards. In 1607, having first insisted on and obtained a recognition of the independence of the Provinces, he began negotiations with Spain with a view to establish a truce. He had to contend against the opposition of the stadtholder and the army, and to suffer from unmerited popular suspicions of taking bribes from the Spanish court. But he triumphed over all difficulties, and on April 9, 1609, the famous twelve years' truce was concluded. From this time Maurice was his sworn foe. The two men were leaders of two great political parties, and the struggle between them was embittered by the admixture of theological and ecclesiastical controversy. In the strife then going on between the Gomarites (the Calvinistic party) and the Arminians, Maurice sided with the former, while Barneveldt supported the latter. Maurice was aiming at the sovereign power; Barneveldt resolutely maintained the freedom of the republic. The clerical party, who looked up to Prince Maurice as their chief, were bent on getting the Calvinistic system established as the state religion, and on refusing to tolerate any other system; Barneveldt and the Arminians contended that each province should be free to adopt the form which it preferred. Barneveldt was the consistent champion of the supremacy of the civil authority, and "the prime minister of Protestantism" (Motley). The convocation of a National Synod was proposed by the party of the stadtholder and resisted by Barneveldt. When disturbances broke out against the Arminians, Maurice refused

to suppress them, and disarmed the militia organized for the purpose by Barneveldt. The former now assumed the chief power. An interview took place on August 17, 1618, between the advocate and the stadtholder; each adhered resolutely to his own views, and the meeting remained fruitless. Barneveldt, with his friends Grotius and Hoogerbeets, was arrested and imprisoned on the 29th. In November following, in pursuance of the command of Prince Maurice, the famous Synod of Dort assembled. A few days later the trial of the prisoners began before a special commission. The proceedings were illegal; the accusations against Barneveldt were fully disproved, but he was unjustly found guilty and sentenced to death. This sentence was unscrupulously confirmed by the clerical synod. It was a foregone conclusion, and Barneveldt had seen clearly that there was no hope for him. On the 14th of May 1619, just five days after the closing of the synod, the venerable statesman and patriot, then in his seventy-first year, was beheaded at the Hague. He met his fate without a word of regret, without a sign of fear. His calm courage and his tenderness of heart are attested by a letter, still extant, written to his wife a few hours before his execution. Besides his wife, Maria van Utrecht, Barneveldt left two sons and two daughters. Four years after their father's death the sons took part in a plot against Prince Maurice; one of them made his escape and entered the service of Spain, the other was arrested and beheaded.

An elaborate history of *The Life and Death of John of Barneveldt, with a View of the Primary Causes and Movements of the Thirty Years' War*, by J. L. Motley, author of the *Rise of the Dutch Republic*, appeared in 1874.

**BARNESLEY**, or **BLACK BARNESLEY**, mentioned in *Domesday Book* as *Barnesleye*, a town and municipal borough in the West Riding of Yorkshire, 171 miles from London and about 11 north of Sheffield. It is situated on rising ground to the west of the River Dearne, in a district of considerable natural beauty. The manufacture of iron and steel, and the weaving of linen and other cloth, are the two principal industries; but there are also bleachfields, printfields, dyeworks, sawmills, cornmills, and malt-houses: and the manufacture of glass, needles, and wire is still carried on. The last-mentioned industry dates from the reign of James I., and was for a long time the staple of the place. There are large coal-fields in the neighbourhood, which, indeed, extend under the town; and these afford employment to considerable numbers. The coal is largely exported to London and Hull, for domestic and other purposes, the coke formed from it also being in great demand. Besides the means of communication afforded by several railway lines, Barnesley has the advantage of two canals, the one known as the *Barnsley-and-Wakefield* and the other as the *Dearne-and-Dova*. Among the more important of its public buildings are the church of St Mary's, St George's (built in 1823), St John's (1858), the county court (1861), and the bank (1861). There are a number of educational and benevolent institutions of some importance; the free grammar school dates from 1665, a subscription library was started in 1808, and a philosophical society was founded in 1828. In 1862 a handsome park of about 20 acres was presented to the town by the widow of Joseph Locke, M.P. About a mile from the town are the ruins of Monk Bretton, a Cluniac priory. Population in 1871, 23,021.

**BARNSTABLE**, a seaport town, and capital of the county of the same name, in the state of Massachusetts, North America. It is situated on the south side of a bay of the same name, which opens into Cape Cod Bay, and is 65 miles S.E. of Boston. The population, which is largely sea-faring, amounted in 1870 to 4793.

**BARNSTAPLE**, a market and borough town of England, county of Devon, 40 miles N.W. of Exeter. It is situated on the River Taw, 6 miles from its mouth, but has always



Arms of Barnstaple.

been considered a seaport. The stream, which is only navigable for small craft, is here crossed by an ancient stone bridge of 16 arches, and by a railway bridge on the Ilfracombe line. The town is handsome and well-built; it was incorporated in the reign of Henry I., and has returned two members to parliament since the time of Edward I. The woollen trade, for which it was once famous, has now entirely declined; but it manufactures lace, sail-cloth, and fishing-nets, and has extensive potteries, tanneries, sawmills, and foundries, while shipbuilding is also successfully carried on. The public buildings and institutions include a large church, a guildhall (1826), a music hall, a free grammar school, a literary institute, national and charity schools, an infirmary (1832), and a dispensary, and the finest market-place in the West of England. The poet Gay was born in the vicinity, and received his education at the grammar school here, which at an earlier period had numbered Bishop Jewel among its *alumni*. Population in 1871, 11,659. Barnstaple is a town of considerable antiquity, and was erected, it is said, by Athelstan into a borough. At the time of the Norman Conquest it numbered between forty and fifty burgesses. Joel of Totness, to whom it was transferred, built a castle and founded a priory of Cluniac monks. In 1588 the town was able to furnish three vessels against the Spanish Armada.

**BAROCCHIO**, or **BAROZZI**, **GIACOMO DA VIGNOLA**, architect, born at Vignola in the Modenese territory, in 1507. He succeeded Michel Angelo as the architect of St Peter's, and executed various portions of that fabric, besides a variety of works in Rome and other parts of Italy. The designs for the Escorial were also supplied by him. He is the author of an excellent work on the *Five Orders of Architecture*. His character as a man was worthy of his genius; for to his extensive acquirements and exquisite taste were superadded an amenity of manners and disposition and a noble generosity, that won the affection and admiration of all who knew him. He died in 1573, at the age of sixty-six.

**BAROCCI**, or **BAROCCIO**, **FEDERIGO**, painter, was born in 1528 at Urbino, where the genius of Raphael inspired him. In his early youth he travelled to Rome, where he painted in fresco, and was warmly commended by Michel Angelo. He then returned to Urbino, where, with the exception of some short visits to Rome, he continued to reside till his death in 1612. He acquired great fame by his paintings of religious subjects, in the style of which he to some extent imitated Correggio. His own followers were very numerous, but according to Lanzi, carried their master's peculiarities to excess. Barocci also etched from his own designs a few prints, which are highly finished, and executed with great softness and delicacy. (See Lanzi, *Hist. of Painting*, i. 440.)

**BARODÁ**, a city of British India, the capital of the native state known as the *Gaikwar's dominions*, is situated near the River Biswamintri, in 22° 16' N. lat., and 73° 14' E. long. The Government of Bombay exercises a political



superintendence over the Gaikwár, and a British political agent resides at Barodá. The town is fortified, but has no great strength. Thornton states the population at 140,000. Barodá contains the chief court of the state, the Gaikwár himself presiding in appeals from the decisions of the other courts in his territory. The town contains only one higher class school, the High School,—attended in 1872 by 658 pupils, of whom 155 were learning English, 221 Marháthi, and 282 Gujráthi. There are also two vernacular schools in the town. The late Gaikwár, Malhár Ráo, was installed in 1871. The princes of Barodá date their importance from the Marhattá confederacy, which in the last century spread devastation and terror over India. Shortly after 1721 the ruling chief, one Peláji, carved a fertile slice of territory out of Gujrát. Another enjoyed the title of "Leader of the Royal Troops" under the Peshwá. During the last thirty-two years of the century the house fell a prey to one of those bitter and unappeasable family feuds which are the ruin of great Indian families. In 1800 the inheritance descended to a prince feeble in body and almost idiotic in mind. British troops were sent in defence of the hereditary ruler against all claimants; a treaty was signed in 1802, by which his independence of the Peshwá, and his dependence on our own Government, were secured. Three years later these and various other engagements were consolidated into a systematic plan for the administration of the Barodá territory, under a prince with a revenue of three quarters of a million sterling, perfectly independent in all internal matters, but practically kept on his throne by subsidiary British troops. Since then the history of the Gaikwárs has been very much the same as that of most territorial houses in India: an occasional able minister, more rarely an able prince; but, on the other hand, a long dreary list of incompetent heads, venal advisers, and taskmasters oppressive to the people. Of late years they have been more than usually unfortunate. Family feuds raged fiercer than ever, and the late Gaikwár was long imprisoned by his brother, the former ruler, on a charge of attempted fratricide. The miserable scandals of the Barodá Ráj need not be revived here. Suffice it to say, that Malhár Ráo found himself suddenly brought from prison and placed upon the throne, and that his conduct as ruler was what might have been expected in such a case. Frequent complaints of his mismanagement and oppression were brought before the British Government, and in 1873 a commission of English officers was appointed to inquire into the affairs of the state, and its management by the Gaikwár. Since then misrule has advanced with a rapid foot. After one or two feints at reforming his government, the Gaikwár returned to his old courses. An attempt in 1874 to poison the British Resident at his court brought affairs to a crisis, and early in 1875 the Gaikwár was tried by a mixed commission of eminent British officers and natives of rank. A unanimous verdict was not obtained touching the particular attempt at poisoning; but Lord Northbrook, as Viceroy of India, found it necessary to depose the Gaikwár, and to appoint another member of the Barodá family to rule in his stead.

**BAROMETER**, the instrument by which the weight or pressure of the atmosphere is estimated. The barometer was invented by Torricelli, a pupil of Galileo, in 1643. It had shortly before been found, in attempting to raise water from a very deep well near Florence, that, in spite of all the pains taken in fitting the piston and valves, the water could by no effort be made to rise higher in the pump than about 32 feet. This remarkable phenomenon Torricelli accounted for by attributing pressure to the air. He reasoned that water will rise in a vacuum only to a certain height, so that the downward pressure or weight of

the column of water will just balance the pressure of the atmosphere; and he further argued that if a fluid heavier than water be used it will not rise so high in the tube as the water. To prove this, he selected a glass tube about a quarter of an inch in diameter and 4 feet long, and hermetically sealed one of its ends; he then filled it with mercury and, applying his finger to the open end, inverted it in a basin containing mercury. The mercury instantly sank to nearly 30 inches above the surface of the mercury in the basin, leaving in the top of the tube an apparent vacuum, which is, indeed, one of the most perfect that can yet be produced, and is called after this great experimenter, the *Torricellian vacuum*. He next converted the mercurial column into a form suited for observation by bending the lower end of the tube, thus constructing what has since been called the siphon barometer. The fundamental principle of the barometer cannot be better illustrated than by his experiment (see fig. 2). In truth, a scale is all that is required to render this simple apparatus a perfect barometer.

The heights of the columns of two fluids in equilibrium are inversely as their specific gravities; and as mercury is 10,784 times heavier than air, the height of the atmosphere would be 10,784 times 30 inches, or nearly five miles, if it were composed of layers equally dense throughout. But since air becomes less dense as we ascend, owing to its great elasticity and the diminished pressure, the real height of the atmosphere is very much greater. From observations of luminous meteors, it has been inferred that the height is at least 120 miles, and that, in an extremely attenuated form, it may even considerably exceed 200 miles.

Various fluids might be used in constructing barometers. If water were used, the barometric column would be about 35 feet long. The advantages, however, which *water barometers* might be supposed to possess in showing changes of atmospheric pressure on a large scale, are more than counterbalanced by a serious objection. The space in the tube above the column of water is far from being a vacuum, being filled with aqueous vapour, which presses on the column with a force varying with the temperature. At a temperature of 32° Fahr. the column would be depressed half an inch, and at 75° a foot. Since in mercurial barometers the space at the top of the column is one of the most perfect vacuums that can be produced, the best fluid for the construction of barometers is mercury. It is therefore the only fluid used where scientific accuracy is aimed at. Pure mercury must be used in filling the tubes of barometers; because if it be impure, the density will not be that of mercury, and, consequently, the length of the columns will not be the same as that of a column composed of pure mercury alone. Even should the density happen to be the same as that of pure mercury the impurities would soon appear, impeding the action of the fluid as it rises and falls, and thus rendering the instrument unfit for accurate observation. In filling barometer tubes, air and moisture get mixed with the mercury, and must be expelled by boiling the mercury in the tube. It being essential that the mercury be quite freed from air and moisture, no barometer should be used till it has been well ascertained that this has been done. Some time after the instrument has been hung in an observing position, let it be inclined gently and with care, so that the mercury may strike against the top of the glass tube; if there is no air within, a sharp metallic click will be heard, but if the sound is dull, the air and moisture have not been entirely expelled. If the mercury should appear at any time to adhere somewhat to the tube and the convex surface assume a more flattened form, it may be concluded that air or moisture is present. If on examining the mercury with a lens minute bubbles are visible, air is present. In all these cases the instrument must be rectified.

The best barometers are usually fitted with an *air-trap*, originally proposed by Gay-Lussac for the purpose of arresting the ascent to the Torricellian vacuum of any air that may have found its way into the column by the cistern. The air-trap is fitted into the tube somewhere between the scale and the cistern. Barometers furnished with an air-trap can be conveyed from place to place with more safety, and they remain longer in good working order.

There are two classes of barometers—*Siphon Barometers* and *Cistern Barometers*. The *Siphon Barometer* (fig. 1) consists of a tube bent in the form of a siphon, and is of the same diameter throughout. A graduated scale passes along the whole length of the tube, and the height of the barometer is ascertained by taking the difference of the readings of the upper and lower limbs respectively. This instrument may also be read by bringing the zero-point of the graduated scale to the level of the surface of the lower limb by means of a screw, and reading off the height at once from the surface of the upper limb. This barometer requires no correction for errors of capillarity or capacity. Since, however, impurities are contracted by the mercury in the lower limb, which is usually in open contact with the air, the satisfactory working of the instrument comes soon to be seriously interfered with.

Fig. 2. shows the *Cistern Barometer* in its essential and its simplest form. This barometer is subject to two kinds of error, the one arising from capillarity, and the other from changes in the level of the surface of the cistern as the mercury rises and falls in the tube, the latter being technically called the *error of capacity*. If a glass tube of small bore be plunged into a vessel containing mercury, it will be observed that the level of the mercury in the tube is not in the line of that of the mercury in the vessel, but somewhat below it, and that the surface is convex. The capillary depression is inversely proportional to the diameter of the tube. If the diameter of the tube be 0.1 inch, the capillary depression of mercury in boiled tubes, or *error of capillarity*, is 0.070 inch; if 0.2 inch, the error is 0.029 inch; if 0.3 inch, it is 0.014 inch; and if 0.5 inch, it is only 0.003 inch. Since capillarity depresses the height of the column, cistern barometers require an addition to be made to the observed height, in order to give the true pressure, the amount depending, of course, on the diameter of the tube.

The error of capacity arises in this way. The height of the barometer is the perpendicular distance between the surface of the mercury in the cistern and the upper surface of the mercurial column. Now, when the barometer falls from 30 to 29 inches, an inch of mercury must flow out of the tube and pass into the cistern, thus raising the cistern level, and, on the other hand, when the barometer rises, mercury must flow out of the cistern into the tube, thus lowering the level of the mercury in the cistern. Since the scales of barometers are usually engraved on their brass cases, which are fixed (and, consequently, the zero-point from which the scale is graduated is also fixed), it follows that, from the incessant changes in the level of the cistern, the readings would be sometimes too high and sometimes too low, if no provision were made against this source of error.

A simple way of correcting the error of capacity is—to ascertain (1) the neutral point of the instrument, or that height at which the zero of the scale is exactly at the height of the surface of the cistern, and (2) the rate of error as the barometer rises or falls above this point, and then apply a correction proportional to this rate. In many of the barometers used on the Continent the surface area of the cistern is 100 times greater than that of the tube, in which case the error is small, and can, besides, be easily calculated. This is a good barometer for ordinary observers, inasmuch as no error arises in bringing the surface of the mercury of the cistern to the zero-point of the scale, which one requires to have some skill as a manipulator and good light to do correctly. Another way of getting rid of this error is effected by the *Board of Trade Barometer*, constructed originally by Adie of London. In this barometer the error of capillarity is allowed for in fixing the zero-point of the scale, and the error of capacity is obviated by making the scale-inches not true inches, but just so much less as exactly to counterbalance the error of capacity.

But the instrument in which the error of capacity is satisfactorily (indeed, entirely) got rid of is *Fortin's Barometer*. Fig. 3 shows how this is effected. The cistern is formed of a glass cylinder, through which the level of the mercury may be seen. The bottom is made like a bag, of flexible leather, against which a screw works. At the top of the interior of the cistern is a small piece of ivory, the point of which coincides with the zero of the scale. By means of the screw, which acts on the flexible cistern bottom, the level of the mercury can be raised or depressed so as to bring the ivory point exactly to the surface of the mercury in the cistern. In some barometers the cistern is fixed, and the ivory point is brought to the level of the mercury in the cistern by raising or depressing the scale.

What is called the *Fitzroy Barometer* is only a modified form of the siphon barometer, with the lower limb blown into a moderately-sized bulb, resembling a cistern in some respects, and thus giving a larger range to the readings of the upper limb. It is only suited for popular, not for scientific purposes. The common *Wheel Barometer*, the popular form of the *weather glass*, is also a modification of the siphon barometer. A small weight, glass or iron, floats on the mercury in the lower limb; to this weight a thread is attached, which is led round a horizontal axis, a small weight being suspended at its free extremity to keep it tight. The float rises and falls with the fluctuations of the barometer, and a pointer fixed to a horizontal axis being turned by this means indicates the height of the barometer by figures on a dial. Since the mercury only rises or falls in the open end of the siphon to the extent of half the oscillation, a cistern is added to the top of the upper limb to increase the amount of the oscillation in the lower limb. This form of the barometer is only suited for very rough purposes, since large and uncertain errors arise from the shortening and lengthening of the thread with the varying dampness or dryness of the air, and from the friction of the different parts of the mechanism of the instrument.

Since in working out the great atmospheric problem of the force of the wind in its relation to the barometric gradient (i.e., the differences of the pressures at different places, reduced to the same level) readings from about the

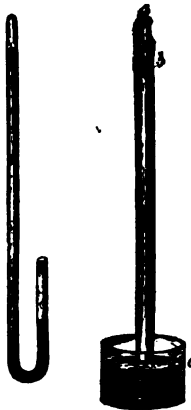

FIG. 1.—  
Siphon  
Barometer.



FIG. 2.—  
Cistern  
Barometer.



FIG. 3.—Fortin's  
Barometer.

hundredth of an inch (0.010), or even less, require to be observed and stated with great accuracy, the extreme importance of accurate sensitive barometers will be apparent,—instruments not only possessing a great range of scale, but a scale which will truly indicate the real atmospheric pressure at all times. The two barometers which best satisfy this requirement are *King's Barometer*, which has been in use for many years at the Liverpool Observatory, and *Housson's Barometer*. Fig. 4 shows the essential and peculiar parts of Housson's barometer. A is the barometer tube, which is of large diameter, and longer than ordinary in order to admit of a greater length of range. B is a movable cylindrical cistern, having attached to its bottom a long hollow tube or stalk c, hermetically sealed, springing to a height of about 28 inches above the fixed level of the mercury in the cistern. This stalk terminates a little below the upper level of the mercury, and its upper end is thus exposed to no more downward pressure than that of the mercury above it; consequently, there is an excess of upward pressure of the air which tends to raise the cistern. When the excess of upward pressure is exactly balanced by the weight of the cistern with its stalk and contained mercury up to b, an equilibrium will be established, which will keep the apparatus stationary or hanging in suspension. If now the atmospheric pressure acting on the cistern be increased, and if the thickness of the glass tube A be supposed to be nothing, the cistern would continue to ascend to an indefinite extent, since there is nothing to stop it. But as the glass is a substance of some thickness, mercury is displaced by the glass as it is plunged further into the cistern; and as it thus offers a resistance to the ascent of the cistern, the cistern will come to rest Barometer when the quantity of mercury displaced is equivalent to the increase of pressure. The extent of range which this barometer possesses over the ordinary barometer is determined by the ratio of the internal area of the tube A to that of the annulus of glass which bounds it,—the range increasing as the internal area is increased, or as the thickness of the glass is diminished.



FIG. 4.—Housson's Barometer

The liability of the barometer to be broken in carriage is great. This risk is considerably lessened in the *Board of Trade Barometer*, which has the tube very much reduced in diameter for a part of its length, breakage from "pumping" being so much lessened thereby that the instrument may be sent as a parcel by rail, if only very ordinary care be taken in the carriage. This is essentially the principle of the *Marine Barometer*, which, however, has the tube still more contracted. For rougher modes of transit an ingeniously constructed iron barometer has been invented by Mr T. Stevenson, C.E.

The *sympiesometer* was invented by Adie of Edinburgh. It consists of a glass tube, with a small chamber at the top and an open cistern below. The upper part of the tube is filled with air, and the lower part and cistern with glycerine. When atmospheric pressure is increased, the air is compressed by the rising of the fluid; but when it is diminished the fluid falls, and the contained air expands. To correct for the error arising from the increased pressure of the contained air when its temperature varies, a thermometer and sliding-scale are added, so that the instrument may be adjusted to the temperature at each observation. It is a sensitive instrument, and well suited for rough purposes at sea and for travelling, but not for exact observation. It has been for some time superseded by the *Aneroid*, which far exceeds it in handiness.

portability, and correctness. The *Aneroid Barometer* was invented by Vidi, and patented in England in 1844. Its action depends on the effect produced by the pressure of the atmosphere on a circular metallic chamber partially exhausted of air and hermetically sealed. Fig. 5 represents the internal construction, as seen when the face is removed, but with the hand still attached. a is a flat circular metallic box, having its upper and under surfaces corrugated in concentric circles. This box or chamber being partially exhausted of air, through the short tube b, which is subsequently made air-tight by soldering, constitutes a spring, which is affected by every variation of pressure in the external atmosphere, the corrugations on its surface increasing its elasticity. At the centre of the upper surface of the exhausted chamber there is a solid cylindrical projection c, to the top of which the principal lever cde is attached, as shown in the drawing. This lever rests partly on a spiral spring at d; it is also supported by two vertical pins, with perfect freedom of motion. The end e of the lever is attached to a second or small lever f, from which a chain g extends to h, where it works on a drum attached to the axis of the hand, connected with a hair spring at k, changing the motion from vertical to horizontal, and regulating the hand, the attachments of which are made to

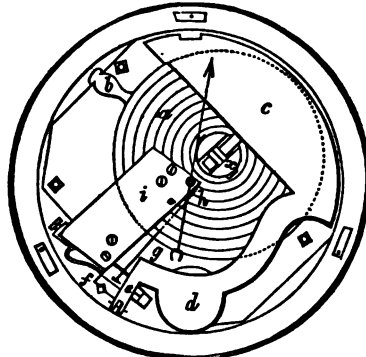

FIG. 5.—Aneroid Barometer.

the metallic plate i. The motion originates in the corrugated elastic box a, the surface of which is depressed or elevated as the weight of the atmosphere is increased or diminished, and this motion is communicated through the levers to the axis of the hand at h. The spiral spring on which the lever rests at d is intended to compensate for the effects of alterations of temperature. The actual movement at the centre of the exhausted box, from whence the indications emanate, is very slight, but by the action of the levers this is multiplied 657 times at the point of the hand, so that a movement of the 220th part of an inch in the box carries the point of the hand through three inches on the dial. The effect of this combination is to multiply the smallest degrees of atmospheric pressure, so as to render them sensible on the index.

The instrument requires, however, to be repeatedly compared with a mercurial barometer, being liable to changes from the elasticity of the brass chamber changing, or from changes in the system of levers which work the pointer. Though aneroids are constructed showing great accuracy in their indications, yet none can lay any claim to the exactness of mercurial barometers. The mechanism is liable to get fouled and otherwise go out of order, so that they may change 0.300 inch in a few weeks, or even indicate pressure so inaccurately and so irregularly that no confidence can be placed in them for even a few days, if the means of comparing them with a mercurial barometer be not at hand.

Of the *self-registering barometers*, the best are those which accomplish this object by photography. This is done by concentrating the rays of a gas flame by means of a lens, so that they strike the top of the mercurial column. A sheet of prepared paper is attached to a frame placed behind a screen, with a narrow vertical slit in the line of the rays. The mercury being opaque throws a part of the paper in the shade, while above the mercury the rays from the flame pass unobstructed to the paper. The paper being carried steadily round on a drum at a given rate per hour, the height of the column of mercury is photographed continuously on the paper. From the photograph the height of the barometer at any instant may be taken. *King's, Hardy's, Hough's, Hipp's, and Thorell's self-registering barometers* may also be referred to as giving continuous records of the pressure. In all continuously registering barometers, however, it is necessary, as a check, to make eye-observations with a mercury standard barometer hanging near the registering barometer from four to eight times daily.

In constructing the best barometers three materials are employed, viz. :—(1) brass, for the case, on which the scale is engraved; (2) glass, for the tube containing the mercury; and (3) the mercury itself. Brass is the best material for the case and scale, inasmuch as its co-efficient of expansion is well known, and is practically the same though the alloy be not in all cases exactly alike. It is evident that if the co-efficient of expansion of mercury and brass were the same, the height of the mercury as indicated by the brass scale would be the true height of the mercurial column. But this is not the case, the co-efficient of expansion for mercury being considerably greater than that for brass. The result is that if a barometer stand at 30 inches when the temperature of the whole instrument, mercury and brass, is 32°, it will no longer stand at 30 inches if the temperature be raised to 69°; in fact, it will then stand at 30.1 inches. This increase in the height of the column by the tenth of an inch is not due to any increase of pressure, but altogether to the greater expansion of the mercury at the higher temperature, as compared with the expansion of the brass case with the engraved scale by which the height is measured. In order, therefore, to compare with each other with exactness barometric observations made at different temperatures, it is necessary to reduce them to the heights at which they would stand at some uniform temperature. The temperature to which such observations are now almost everywhere reduced is 32° Fahr.

The following is Schumacher's formula for computing the corrections for barometers, whose heights are noted in English inches, for temperature  $t$ , according to Fahrenheit's scale :—

$$s = -\lambda \frac{m(t - 32^\circ) - s(t - 62^\circ)}{1 + m(t - 32^\circ)},$$

where  $\lambda$  = height of barometer,

$m$  = expansion of mercury for 1° Fahr. = 0.0001001,

$s$  = expansion of brass for 1° Fahr. = 0.00001041.

The standard temperature of the English yard being 62° and not 32°, it will be found in working out the corrections from the above formula that the temperature of no correction is not 32° but 28°.5. If the scale be engraved on the glass tube, or if the instrument be furnished with a glass scale or with a wooden scale, different corrections are required. These may be worked out from the above formula by substituting for the co-efficient of the expansion of brass that of glass which is assumed to be 0.00000498, or that of wood, which is assumed to be 0. Wood, however, should not be used, its expansion with temperature being unsteady, as well as uncertain.

If the brass scale be attached to a wooden frame and be free to move up and down the frame, as is the case with

many siphon barometers, the corrections for brass scales are to be used, since the zero-point of the scale is brought to the level of the lower limb; but if the brass scale be fixed to a wooden frame, the corrections for brass scales are only applicable provided the zero of the scale be fixed at (or nearly at) the zero line of the column, and be free to expand upwards. In siphon barometers, with which an observation is made from two readings on the scale, the scale must be free to expand in one direction. Again, if only the upper part of the scale, say from 27 to 31 inches, be screwed to a wooden frame, it is evident that not the corrections for brass scales, but those for wooden scales must be used. No account needs to be taken of the expansion of the glass tube containing the mercury, it being evident that no correction for this expansion is required in the case of any barometer the height of which is measured from the surface of the mercury in the cistern.

In fixing a barometer for observation, it is indispensable that it be hung in a perpendicular position, seeing that it is the *perpendicular distance* of the surface of the mercury in the cistern and that of the top of the column which is the true height of the barometer. Hence it is desirable that the barometer swing in position; or if this be attended with risk or inconvenience, it must be seen that it be clamped or permanently fixed in a position exactly vertical. The surface of the mercurial column is convex, and in noting the height of the barometer, it is not the chord of the curve,—an error not unfrequently made,—but its tangent which is taken. This is done by setting the straight lower edge of the vernier, an appendage with which the barometer is furnished, as a tangent to the curve. The vernier is made to slide up and down the scale, and by it the height of the barometer may be read true to 0.002 or even to 0.001 inch. See VERNIER.

In hanging a barometer the following points should be attended to :—(1), That it be hung so that the mercurial column be quite perpendicular; (2), that the scale be about 5 feet high, for facility of reading; (3), that the whole instrument, particularly the scale and the cistern, be hung in a good light; and (4), that it be hung in a position in which it will be exposed to as little fluctuation of temperature as possible. A wall heated by a fire, and positions which expose the instrument to the heat of the sun or to that of a fire, are very objectionable. It is to be kept in mind that no barometric observation can be regarded as good unless the *attached thermometer* indicates a temperature differing from that of the whole instrument not more than a degree. For every degree of temperature the attached thermometer differs from the barometer, the observation will be faulty to the extent of about 0.003 inch, which in discussions of diurnal range, barometric gradients, lunar range, and many other questions, is a serious amount.

Before being used, barometers should be thoroughly examined as to the state of the mercury, the size of cistern (so as to admit of low readings), and their agreement with some known standard instrument at different points of the scale. The pressure of the atmosphere is not expressed by the weight of the mercury sustained in the tube by it, but by the perpendicular height of the column. Thus, when the height of the column is 30 inches, it is not said that the atmospheric pressure is 14.7 lb on the square inch, or the weight of the mercury filling a tube at that height whose transverse section equals a square inch, but that it is 30 inches, meaning that the pressure will sustain a column of mercury of that height.

The height of the barometer is expressed in English inches in England and America. In France and most European countries, the height is given in millimètres, a millimètre being the thousandth part of a mètre, which equals 39.37079 English inches. Up to 1869 the barometer

was given in half-lines in Russia, which, equalling the twentieth of an English inch, were readily reduced to English inches by dividing by 20. The metric barometric scale is now used in Russia. In a few countries on the Continent the French or Paris line, equalling 0.088814 inch, still continues to be used. Probably millimètre and English inch scales will soon be exclusively in use. The English measure of length being a standard at 62° Fahr., the old French measure at 61°·2, and the metric scale at 32°, it is necessary, before comparing observations made with the three barometers, to reduce them to the same temperature, so as to neutralize the inequalities arising from the expansion of the scales by heat.

The barometer is a valuable instrument as an indicator of coming weather, provided its readings be interpreted with intelligence. High pressures generally attend fine weather, but they not unfrequently accompany wet stormy weather, on the other hand, low pressures, which usually occur with wet and stormy weather, not unfrequently accompany fine mild weather, particularly in winter and in the northern parts of Great Britain. The truth is, the barometer merely indicates atmospheric pressure directly, whilst it indicates weather only inferentially. The chief points to be attended to are its fluctuations taken in connection with the wind and the state of the sky, but above all, the readings of the barometer as compared with those at neighbouring places, since it is *differences* of pressure, or the amount of the barometric gradient, which determines the strength of the wind and the weather generally.

*Barometrical Measurements of Heights.*

The decisive experiment by which Pascal established the reality of atmospheric pressure suggested to him the method of measuring heights by means of the barometer. The first attempts to effect this were necessarily rude and inaccurate, since they went on the assumption that the lower mass of air is of uniform density. The discovery, however, of the actual relation subsisting between the density of air and its elasticity by Boyle in England, and about the same time by Mariotte in France, laid a sure foundation for this branch of atmospheric physics—the relation being that, at the same temperature, the pressure of a gas is exactly proportional to its density.

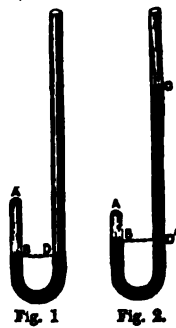

The truth of this law may be shown by the following experiment. Take a glass tube, of equal bore throughout, closed at one end, and bent in the form of a siphon (fig. 1), and let us suppose that it contains in the closed limb a portion of air AB, shut off from the atmosphere by mercury filling the lower portion of the tube, and that the enclosed portion of air exists at the ordinary pressure of the atmosphere or 30 inches. In this case the mercury in each limb, being subject to the same pressure, will stand at the same level. If we now pour mercury into the long limb (fig. 2) till the level in this limb stands 30 inches above the level in the closed limb, the additional mercury will tend to compress the air in A'B' with a pressure equal to that exerted by a column of 30 inches of mercury. In the latter case, therefore, the air is subjected to a pressure of two atmospheres, or 60 inches, while in the former it was only subjected to a pressure of one atmosphere or 30 inches. It will be found that the space A'B' under the pressure of two atmospheres is only half the space AB where the pressure is only one atmosphere. If mercury had been

filled in till the difference of level of the mercury in the two limbs was 60 inches, or a pressure of three atmospheres, the space occupied by the air in the closed limb would have been only a third of the original space when the pressure was only that of one atmosphere. Generally, Boyle's law or Mariotte's law is this:—The volume of a gas varies inversely as the pressure. Since the same quantity of air has been experimented with, it follows that the density is doubled with a pressure of two atmospheres, and trebled with that of three, and hence the pressure of a gas is proportional to its density.

This law, however, only holds provided the temperature is the same. The familiar illustration of a bladder, partially filled with air, expanding on being placed near a fire, shows that if the pressure remains the same,—the pressure in this case being that of the atmosphere,—the gas will occupy a larger space if its temperature be raised. If the temperature be increased and the air be confined so as to occupy the same space, the pressure will be increased.

The relation between the temperature and pressure of gases was first discovered by Gay-Lussac; and more recently our knowledge of this branch of the subject has been greatly enlarged by the beautiful and accurate experiments of Regnault. From those experiments it has been concluded that the co-efficient which denotes increase of elasticity for 1° Fahr. of air whose volume is constant equals .002036; and that the co-efficient which denotes increase of volume for 1° Fahr. of air whose elasticity is constant equals .002039. It may further be added that the co-efficient of expansion for carbonic acid gas, hydrogen, and all other gases, is as nearly as possible the same.

When a fluid is allowed to evaporate in the exhausted receiver of an air-pump, vapour rises from it until its pressure reaches a certain point, after which all further evaporation is arrested. This point depends on the nature of the fluid itself and on the temperature, and it indicates the greatest vapour pressure possible for the fluid at the particular temperature. Regnault has shown the amount of the vapour pressure of water at different temperatures, thus—

Temp. Fahr.	Max. Pressure of Vapour. Inch.	Temp. Fahr.	Max. Pressure of Vapour. Inch.
0	0.044	50	0.361
10	0.068	60	0.618
20	0.108	70	0.783
30	0.165	80	1.023
40	0.248	90	1.410

If gases of different densities be put into the same vessel it is found that they do not arrange themselves according to their densities, but are ultimately diffused through each other in the most intimate manner. Each gas tends to diffuse itself as in a vacuum, the effect of the presence of other gases being merely to retard the process of their mutual diffusion. As regards the atmosphere, evaporation goes on until the maximum vapour pressure for the temperature has been attained, at which point the air is said to be saturated, and whilst the temperature remains the same further evaporation is arrested. Thus, at a temperature of 50° evaporation goes on until the vapour pressure reaches 0.361 inch, but if the temperature were raised to 60° the process of evaporation would be renewed, and go on till the vapour pressure rose to 0.618 inch. If at a vapour pressure of 0.618 inch the temperature were to fall from 60° to 50°, the air would no longer be capable of retaining the whole of the aqueous vapour in suspension, but the surplus part would be condensed and fall as rain. In the change from the aeriform to the liquid state a quantity of latent heat is given out. The yet uncertain effect of these changes, particularly the change of form from the aeriform to the liquid state, on the pressure, temperature, and movements of the air, renders it peculiarly desirable that barometric observations for the determination of

heights should not be made when clouds are forming or rain is falling.

Dalton has shown<sup>1</sup> that air charged with vapour is specifically lighter than when it wants the vapour; in other words, the more vapour any given quantity of air has in it the less is its specific gravity; and Sir William Thomson has shown<sup>2</sup> that the condensation of vapour in ascending currents of air is the chief cause of the cooling effect being so much less than that which would be experienced by dry air. From these ascertained effects of aqueous vapour in modifying the pressure and temperature of the atmosphere, the importance in the barometric measurement of heights of full and accurate observations of the hygrometry of the atmosphere and of the weather will be apparent.

Since the equilibrium of the vapour atmosphere is being constantly disturbed by every instance of condensation, by the ceaseless process of evaporation, and by every change of temperature, and since the presence of oxygen and nitrogen greatly obstructs the free diffusion of the aqueous vapours, it follows that Dalton's law of the independent pressure of the vapour and the dry air does not absolutely hold good. From the constant effort of the vapour to attain to a state of equilibrium there is, however, a continual tendency to approach this state. Since the equal diffusion of the dry air and the vapour is never reached, observations can only indicate local humidity, and therefore as regards any considerable stratum of air can only be regarded as approximate. Though particular observations may often indicate a humidity wide of the mark, yet in long averages a close approximation is reached, except in confined localities which are exceptionally damp or dry. Hence in observations for the determination of heights, the results of a long-continued series of observations should be employed, and those hours should be chosen whose mean is near the daily mean.

The most recent results arrived at by Regnault are the best, but it is to be regretted that the whole subject of the hygrometry, both as regards the methods of observation and the methods of discussing the observations, is still in an unsatisfactory state. This consideration, taken in connection with our defective knowledge of the relation of aqueous vapour to radiant heat, of the mode of its diffusion both vertically and horizontally, and of the influence exerted by its condensation into cloud and rain, and with our ignorance of the merely mechanical effects of ascending, descending, and horizontal currents of air in increasing or diminishing barometric pressure, renders it evident that heights deduced from barometric observations can only be regarded as approximate. It is much to be desired, in stating results, that the limit of error were taken into account, and the nearest round number in accordance therewith should alone be given as the calculated result. Thus, it is a mistake to give as the height of a place 1999 feet when the calculation is based wholly on barometric observations, and the limit of error amounts to 30 feet or more. The height 2000 should be given as the result.

The correction for decrease of gravity at the higher station, as compared with the force of gravity at the lower station or at sea-level, must also be taken into account. Its amount is small, being, roughly speaking, only about 0.001 inch per 400 feet. Since the force of gravity is diminished in proportion to the square of the distance from the centre of gravity, the rate of its decrease with the height varies in different latitudes. Places at the equator being farther from the earth's centre than places at the poles, it follows that the force of gravity diminishes at a less rapid rate as we ascend at the equator than it does at the poles. Now,

since at the equator gravity diminishes less rapidly with the height, the air at any given height will exert a higher pressure there than anywhere else on the globe at the same height as compared with what it does at the sea-level of the latitude. Hence a subtraction requires to be made at the equator, and the amount to be subtracted diminishes as we proceed into higher latitudes, till it falls to zero at latitude 45°, where the force of gravity is assumed to be the mean. For higher latitudes an addition is required which constantly increases till it reaches the maximum at the poles. This correction is also small, being for 1000 feet less than 0.001 inch in Great Britain, and less than 0.003 at the equator and the poles.

Various formulae for the barometrical measurement of heights, based on these principles, have been given by Laplace and others, not a few of them being unnecessarily refined and intricate when the real character of the data is taken into consideration. The following formula by Rühlmann<sup>3</sup> is given as the simplest and best, being based on the most recent results which have been arrived at:—

$$h = 18400.2 \left( 1.00157 + 0.002675 \frac{t' + t''}{2} \right) \left( 1 + 0.378 \frac{v' + v''}{2} \right) (1 + 0.002623 \cos 2\phi) \left( 1 + \frac{2s + h}{6378150} \right) \log \frac{V}{V'}$$

in which  $h$  is the difference in metres of level between the two stations;  $t'$  and  $t''$  the temperature centigrade of the air at the two stations;  $v'$  and  $v''$  the heights of the barometer in millimetres, corrected for temperature and for all instrumental errors;  $\phi$  the mean of the latitudes of the two stations; and  $s$  the height of the lower station above the sea. Making—

$$A = \log \left\{ 18400.2 \left( 1.00157 + 0.002675 \frac{t' + t''}{2} \right) \right\},$$

$$C = \log \left\{ 1 + \frac{0.378}{2} \left( \frac{v' + v''}{2} \right) \right\},$$

$$D = \log \left\{ 1 + 0.002623 \cos 2\phi \right\},$$

$$E = \log \left\{ 1 + \frac{2s + h}{6378150} \right\}.$$

Rühlmann has calculated the values  $A$ ,  $C$ ,  $D$ , and  $E$  for the different values of the respective arguments, which are given in the tables appended to the work.

From formula (1) we obtain—

$$\log h = \log \left\{ \log \frac{V}{V'} - \log V' \right\} + (A + C + D + E) \dots (2).$$

It is assumed that the whole stratum of air between the two heights is in a state of rest, and that the means of the temperature and humidity observed at the two stations are the means respectively of the stratum of air between them.

If great accuracy is desired, both barometers must be read from the zeros of their scales, and the observations must be corrected for all merely instrumental errors, and must be made strictly at the same time or times, seeing that a very small error, arising either from imperfect observations, or from their not being comparable, produces a comparatively large error in the calculated results.

In deducing heights from long-continued observations it should be ascertained that the barometers and observations are good, and observations should if possible be used which have been made at the same hours of the day and during the same years. Observations at different hours of the day are not comparable, since, owing to our imperfect knowledge of the differences of daily barometric range, the

<sup>1</sup> *Meteorological Observations and Essays*, 2d ed., p. 100.  
<sup>2</sup> *Mem. Lit. and Phil. Soc. Manchester*, vol. II. 5d series, p. 181.

<sup>3</sup> *Die Barometrischen Höhenmessungen und ihre Bedeutung für die Physik der Atmosphäre*, von Dr Richard Rühlmann, Leipzig, 1870.

necessity for the application of any so-called corrections for daily range must necessarily lead to error. The comparison should also only be between observations made during the same years, since the means of different years often differ widely from each other. Thus the difference of height between two places at which barometrical observations were made, from 1830 to 1859 and from 1850 to 1869 respectively, could be more accurately ascertained from the ten years' averages from 1850 to 1859 during which observations were made at both places, than from the longer averages of thirty and twenty years. Inattention to this point has often led to error, especially in cases where at one of the places only a few years were available. To secure greater accuracy, the calculations should be made on the mean for the year, the two extreme months, January and July, and that month during which the distribution of pressure is most uniform over the region where the places are situated. Owing to the great differences in the distribution of atmospheric pressure in different parts of the globe (see *ATMOSPHERE*), comparison of the observations at the higher station with those at more than one lower station is in some cases indispensable. Thus, if it were desired to compute the height of Dovre, in Norway, barometrically, it should be compared both with Christiania and with Christiansund on the west coast; for if compared with Christiania alone the calculated height would be too high, and if with Christiansund too low, the reason being that the mean annual pressure diminishes from Christiania to Christiansund. The same remark applies to a large portion of Hindustan and to many other regions of the globe.

The more special precautions to be taken in deducing heights from one or a few observations, that is, from such data as travellers observe, are these:—that the observations be made in as settled weather as possible, at those hours of the day, at least, at which observations are made at the nearest meteorological stations, and be repeated as long as possible from day to day; that the barometer hang perpendicularly and in shade; and that the observations be not made till the whole instrument has acquired the temperature of the surrounding air. For, for every degree which the temperature indicated by the attached thermometer differs from the temperature of the whole instrument, there is an error of about 0.003 inch.

From their portability and handiness the aneroid barometer, and the thermometer for ascertaining the point at which water boils, are of great use in determining heights,—the thermometer, if properly managed, being the more accurate of the two. Since, owing to the sluggishness with which the aneroid often follows the changes of pressure, especially low pressures, its readings should not be recorded till it has hung for some hours at the place of observation, and if this be not possible, the time which elapsed from arriving at the place and making the observations should be stated. It may not be unnecessary to add that every opportunity which presents itself should be taken of comparing it with a standard mercurial barometer, owing to the variations, irregular or permanent, to which aneroids are subject, and that the instrument should always be read in one position, since the difference between the reading in a horizontal position and the reading in a vertical position is often considerable.

At a pressure of 29.905 inches distilled water boils at 212°. The temperature of the boiling point varies with the nature of the vessel. Thus, if the interior of the glass vessel be varnished with shell-lac, the temperature may rise to 221°; and if iron filings be dropped into the water, the temperature is lowered. But in all these cases the temperature of the vapour arising from the water is as nearly as possible the same. Hence in making observations with the thermometer for hypometrical purposes, the

instrument is not plunged into the water, but the whole instrument, bulb and stem, are by an apparatus used for the purpose plunged into the vapour arising from the boiling water. The degrees on the thermometer used are greatly enlarged, thus admitting of a minute subdivision of the scale and, consequently, of very precise readings. The following are a few of the barometrical heights corresponding to different temperatures at which distilled water boils, taken from Regnault's tables revised by Moritz:—

Boiling Point.	Barometer.	Boiling Point.	Barometer.
	inches.		inches.
211	29.831	205	29.990
210	29.751	204	29.465
209	28.180	203	24.949
208	27.618	202	24.423
207	27.066	201	23.948
206	26.523	200	23.453

The temperature of the vapour of the boiling water being observed, the pressure is ascertained from the table, whence the height may be calculated, just as in the case of pressures obtained by means of a mercurial barometer.

The remark made by Sir John Leslie many years ago still holds good, that it is preposterous, in the actual state of physical science, to effect any high refinement in the formula for computing barometrical heights. What is required on the part of the computer of heights from barometrical observations is carefully to weigh the *limits of error* due to the instrument and methods of observations, to the hour of the day and the month of the year (see *ATMOSPHERE*, p. 28), and to the degree of unsettledness of the weather at the time the observations were made, and to give effect to those in the calculated results. From inattention to these simple considerations a large proportion of important heights given in works of travel and of physical geography are very erroneously stated, and consequently require careful revision.

For very rough approximations to the real height from observations of pressure and temperature, Sir G. B. Airy has prepared a table showing the differences of level corresponding to differences of pressure. It is from this table that the heights corresponding to pressures engraved on many aneroids are usually taken. The heights read off from the pressures should be corrected for observations of temperature carefully taken at the upper and lower stations, the mean of these two observations being assumed as the mean of the stratum of air occupying the interval between the two heights.

(A. R.)

**BARON.** The origin and primary import of this term have been much contested. Menage derives it from the Latin *baro*, a word which we find used in classical Latin to signify "a simple" or "foolish man" (*Cic. Fin.*, ii. 23). Another form of the same word appears to be *barus*, to which Lucilius gives the meaning "a stupid man," "a blockhead," Forcellini observing that its primary sense is "a block of tough, hard wood." But with greater probability Graff derives the word baron from the old German *Bar = Mann, freier Mann*. The word seems related to the Spanish *varon*, which means "a male," "a noble person," and its root may be found in the Sanskrit *varā*. Like the Greek *εὐρύς* and the Latin *vir*, the word *baron* signifies man in general and also a husband—the old legal expression *baron and feme* being equivalent to our ordinary phrase "man and wife."

In modern English usage the term is particularly applied to a member of the lowest order of the peerage, but in ancient records (as Lord Coke observes) the barony included all the (titular) nobility of England, because all noblemen were barons though they might possess a higher dignity also; and the great council of peers, in which were included dukes, marquesses, and earls, as well as barons, was styled simply the "Council de Baronage." In like manner we

speak of the "barons' wars," and "the barons" who signed Magna Charta, although nobles of higher rank joined in both, and it is usual in summoning to the Upper House a peer's son in the lifetime of the father, to give, for the occasion, a separate existence to the latter's barony.<sup>1</sup> Thus Earl Fortescue sat in the House of Lords during his father's lifetime as baron of Castle Hill, county Devon—the barony held with his father's earldom. The fiction is still maintained when a commoner is raised directly to one of the higher grades of the peerage, as in the case of Admiral Jervis, who was created at the same time Baron Jervis and Earl St Vincent.

The origin and comparative antiquity of barons have been the subject of much research amongst antiquaries. The most probable opinion is that they were the same as our present lords of manors; and to this the appellation of *court-baron*, given to the lord's court, and incident to every manor, seems to lend countenance. The term baron had, therefore, originally a very extensive meaning, being applicable to all tenants-in-chief of the Crown, whether holding by knight service or by grand serjeantry. But the latter only were in the narrower sense the king's barons, and as such possessed both a civil and criminal jurisdiction, each in his *curia baronum*, and were entitled to seats in the great council of the nation. "For," says Sir H. Nicolas, "it was the principle of the feudal system that every tenant should attend the court of his immediate superior; and hence it was that he who held *per baroniam*, having no superior but the Crown, was bound to attend his sovereign in his great council or parliament, which was, in fact, the great court baron of the realm" (*Historic Peerage of England*, ed. Courthope, p. 18). The lesser barons—those, namely, who held by knight service—were also occasionally summoned to parliament, but upon no fixed principles, and "the irregularity of passing over many of them when councils were held for the purpose of levying money, led to the provision in the Great Charter of John, by which the king promises that they shall be summoned through the sheriff on such occasions" (Hallam, *Middle Ages*, iii. 21). Both these classes, but the former especially, might be entitled to the appellation of *Barons by Tenure*; but it is evident that the mere possession of a barony (i.e., thirteen knight's fees and a quarter) did not give its possessor an absolute right to a seat in parliament, and, of course, all such baronies must have been swept away by the Act of 12 Car. II. c. 24, abolishing feudal tenures and whatever depended thereupon. But from the reign of Henry III. (49th year) the barons were summoned to attend the king in council or parliament *by writ*, and thus the dignity ceased to be territorial and became altogether personal. And although the writ, whether addressed to ancient barons or to those who had not before been peers of parliament, contained no words of limitation to the heirs of the person summoned, yet it was laid down by Coke, and has always been accepted, that it ennobles the blood of the person summoned, and that thus the barony becomes heritable by heirs, male or female. A further change by King Richard II. in the 11th year of his reign, when he created John Beauchamp de Holt baron of Kidderminster by *letters patent*, and since that date this mode of conferring the dignity of a baron has been pursued. Dugdale states that the solemn investiture of barons created by patent was performed by the king himself, by enrobing the peer in scarlet, and this form continued till 13 Jac. I., when the lawyers declared that the delivery of the letters patent without ceremony was sufficient. The letters

<sup>1</sup> The practice commenced, as Dugdale states, the 2d. Edw. IV., but came into more general use in the latter part of the 17th century. It will be understood that it was designed to "accelerate the possession" of a dignity, and not to create a second.

patent express the limits of inheritance of the barony. The usual limit is to the grantee and heirs male of his body; occasionally (as in the case of Lord Brougham) in default of male issue, to a collateral male relative; and occasionally (as in the case of Lord Nelson) to the heirs of a sister. The coronation robes of a baron are the same as those of an earl, except that he has only two rows of spots on each shoulder; and, in like manner, his parliamentary robes have but two guards of white fur, with rows of gold lace; but in other respects they are the same as those of other peers. King Charles II. granted to the barons a coronet, having six large pearls set at equal distances on the chaplet. A baron's cap is the same as a viscount's. His style is *Right Honourable*; and he is addressed by the king or queen, *Right Trusty and Well Beloved*.

*Barons of the Exchequer*, six judges (a chief baron and five puisne barons) to whom the administration of justice is committed in causes betwixt the king and his subjects relative to matters of revenue. Selden, in his *Titles of Honour*, conjectures that they were originally chosen from among the barons of the kingdom, and hence their name.

*Barons of the Cinque Ports* (originally Hastings, Dover, Hythe, Romney, and Sandwich) were (prior to 1831) members of the House of Commons, elected by the Cinque Ports, two for each port. Their right to the title is recognized in many old statutes, but in 1606 the use of the term in a message from the Lower House drew forth a protest from the peers, that "they would never acknowledge any man that sitteth in the Lower House to the right or title of a baron of parliament" (*Lord Journals*). These ports are now under the jurisdiction of a *warden*.

*Baron and Feme*, in the *English Law*, a term used for husband and wife, in relation to each other, who are accounted as one person. Hence, by the aid law of evidence the one party was excluded from being evidence for or against the other in civil questions, and a relic of it is still preserved in the criminal law.

*Baron and Feme*, in *Heraldry*, is when the coats-of-arms of a man and his wife are borne *per pale* in the same escutcheon,—the man's being always on the dexter side, and the woman's on the sinister. But in this case the woman is supposed not to be an heiress, for then her coat must be borne by the husband on an escutcheon of pretence. See HERALDRY. (A. J. R.)

**BARONET**, a name originally given to the *lesser barons* mentioned in the preceding article, but now confined to the lowest grade of our hereditary nobility. The order was instituted by King James I. in 1611, at the suggestion of Sir Robert Cotton, to whom the plan had been submitted by Sir Thomas Sherley of Wiston, its actual inventor. Originally, the creation of this order was merely an expedient to raise money, and the cost of a baronetcy in each case amounted to £1095, exclusive of the fees. The money thus raised was professedly destined for the defence and maintenance of the new plantation in the province of Ulster, but it actually passed at once into the king's exhausted exchequer. According to the instructions given to the commissioners appointed for admitting to the new dignity, none were eligible but "men of quality, state of living, and good reputation, worthy of the same, and, at the least, descended of a grandfather (by the father's side) that bore arms, and who have also of certain yearly revenue"—£1000 per annum. The number created at first was 200, and the king engaged for himself, his heirs, and successors, that this should not be exceeded; and for himself also promised that no vacancies in the original number should be filled up. Charles I. disregarded the stipulated limitation, and the original terms have never since been carried out. The first twenty patents issued



were dated 22d May 1611, and begin with that given to Sir Nicholas Bacon (son of the lord keeper) whose descendant still retains the position of premier baronet of England.

Baronets take precedence according to the dates of their patents, conformably to the terms of which no intermediate honour between baron and baronets can be established, and they rank above all knights except those of the Garter. The title or prefix of *Sir* is granted them by a peculiar clause in their patents, and until 1827 they could claim for themselves and the heirs male of their bodies the honour of knighthood. All baronets are entitled to bear in their coats-of-arms, either in a canton or an escutcheon at their choice, the arms of Ulster, viz., a bloody hand.

*Baronets of Scotland*, called also *Baronets of Nova Scotia*.—This order of knights-baronets was instituted by Charles I. in the year 1625, when the first person dignified with the title was Sir Robert Gordon of Gordonstone, a younger son of the earl of Sutherland. The professed object of the institution was to encourage the plantation and settlement of Nova Scotia in North America; hence the king granted to each of them a certain portion of land in that province, which they were to hold of Sir William Alexander, afterwards earl of Stirling, with precedence to them and their heirs-male for ever, before all knights called *equites curati*, all lesser barons called *lairds*, and all other gentlemen, except Sir William Alexander, his Majesty's lieutenant in Nova Scotia, his heirs, their wives and children. It was further provided that the title of *Sir* should be prefixed to their Christian name, and *Baronet* added to their surname; and that their own and their eldest sons' wives should enjoy the title of *Lady*, *Madam*, or *Dame*. The baronets of Scotland had assigned to them as an addition to their armorial bearings the ensign of Nova Scotia, viz., argent, a cross of St Andrew, azure, to be borne in a canton or in escutcheon; but in 1629, after Nova Scotia was sold to the French, this privilege was changed into permission to wear a badge about their necks pendent from an orange-tawny silk ribbon.

Malone has given the following curious note upon this subject, in his learned *Life of Dryden*, prefixed to his edition of the prose works of that writer:—

“When the order of baronets was first established in 1611, King James engaged that they should not exceed two hundred. However, towards the close of his reign, that number being completed, and the creation of baronets being found a useful engine of Government (the courtier by whose influence the title was obtained receiving usually £1000 for the grant), it was not lightly to be parted with. A scheme, therefore, of creating *Baronets of Scotland* was devised, which, if it was conceived, would be no infraction of the original compact to confine the grants to a limited number; and as the English baronets were created under the great seal of England, for the reduction of Ulster in Ireland, so the Scottish baronets were created under the great seal of Scotland, for the reduction of Acadia, or *Nova Scotia*. The scheme, however, was not carried into execution by King James; but early in the reign of his successor several Scottish baronets were made. From this statement it appears that there is no more necessity for calling a baronet created under the great seal of Scotland (whether he be an Englishman or Scotchman), a *Baronet of Nova Scotia*, than there is to denominate one created under the great seal of England a *Baronet of Ulster*.”—(Malone's *Dryden*, vol. i. pp. 28, 29.)

After the Union with England in 1707 the baronets of Scotland charged their arms with the Ulster badge, being created as baronets of the United Kingdom.

*Baronets of Ireland*.—This order was likewise instituted by King James I. in the 18th year of his reign, for the same purpose and with the same privileges within the kingdom of Ireland as had been conferred on the analogous order in England; for which also the Irish baronets paid the same fees into the treasury of Ireland. (G. J. R.)

BARONIUS, CÉSAR, the great church historian, was born on the 31st October 1538 in the district of Naples. His parents, Camillo de Barono or Baronio and Porcia

Trebonia, were of noble birth. He was educated at Veroli and Naples, where his favourite studies were theology and jurisprudence. In 1557 he accompanied his father to Rome, and found himself in the midst of the reactionary enthusiasm which did much to restore Italy, in spite of the efforts of her reformers, to the papal authority. There he was brought in contact with Philip Neri, a man who then and since has done much to reconcile the speculative student with the Church of Rome, and to provide for him work in her service to which he can give his whole heart. Neri had just founded the Italian Oratory, the model of many another, and he and his monks had vowed to devote themselves to student lives, and to dedicate their whole power of study to the Roman Catholic Church. Among the theological studies pursued in the oratory, church history and ecclesiastical biography held a prominent place, the greater part of every forenoon being set apart for these subjects. In this small congregation Baronius found a congenial home, and his superior, Philip Neri, soon saw that he had secured a coadjutor who would make his oratory all he had hoped it would become. The alarm caused by the first Protestant church history, the *Magdeburg Centuries*, gave his studies a special direction, and, as he told Pope Sixtus V., he was urged by his own desires, and the encouragement of Neri, to attempt to answer the *Annales Ecclesiastici*, his great work, which occupied thirty laborious years. These *Annales*, the first and in many respects the most important historical work which the Roman Catholic Church has produced, begin with the birth of Christ and end with the year 1198. The book is not properly history; it is annals rather, as everything is subordinated to chronology. The year is first given, then the reigning Pope and the year of his reign, then the emperors of the East and West, and, after its institution, the name and year of the emperor of the Holy Roman empire. This chronological form had one advantage—theology was kept as much as possible in the background, and the facts of history were the very most important part. The *Annales* have thus become very important to every student of church history whether Protestant or Roman Catholic. While Baronius was engaged in his great work he was encouraged by several marks of papal favour. He was named pronotarius of the papal chair; in 1596 he was elected a cardinal; and he was afterwards chosen to fill the much-coveted post of librarian of the Vatican. He died on the 30th of June 1607. The best and most useful edition of his works is that of Mansi, in 38 vols. fol.; it gives Fagii's *critica historico-theologica*, or corrections of Baronius, at the foot of each page. The best text is the Antwerp edition of 1610.

BARQUISIMETO, a city of Venezuela, and since 1830 the capital of the province of Nueva Segovia, is situated on a confluent of the Portuguesa, which belongs to the northern part of the Orinoco system. The surrounding district is fertile, and produces excellent coffee, cocoa, and sugar; and the climate is healthy and pleasant. Barquisimeto was founded in 1523 by Juan de Villegas, principally for the exploration and working of gold-mines supposed to exist in the neighbourhood; and at first it received the name of Nueva Segovia in honour of his native city. The commercial advantages of its situation soon raised it to considerable prosperity. In 1807 it had about 15,000 inhabitants; but on the 26th of March 1812, it was totally destroyed by an earthquake. It has since been regularly rebuilt, and, in spite of the disastrous effects of the revolutionary wars, has recovered its position. Among its public buildings may be mentioned a college and several schools. The inhabitants are partly engaged in the rearing of horses and mules. Population in 1878, 25,664.

**BARR**, a town in Alsace, 18 miles S.W. of Strasburg, situated on the eastern slope of the Vosges, at the mouth of the Ulrichthal. Wool and cotton spinning, and the manufacture of pottery, crystal, and soap, are its principal industries; and an active trade is carried on in wine, brandy, vinegar, cattle, and wood. The town is mentioned as early as the 8th century. It was burned by the troops of the Cardinal of Lorraine in 1592; in 1678 it suffered from a severe conflagration; and in 1794 it was greatly damaged by the explosion of the arsenal. There is a tepid mineral spring in the neighbourhood, and, on the Odilienberg, which rises above the town, are the ruins of the convent of St Odilia, which was founded in the 7th century. Population, 5661.

**BARRA**, or **BARRAY** (from the Scandinavian *Barraey*, isle of the ocean), one of the Hebrides or Western Isles of Scotland, forming part of Inverness-shire. It lies about 5 miles S.W. of South Uist, and is 8 miles in length by from 2 to 4 miles in breadth. The parish comprehends a number of smaller islands and islets,—Berneray, Flodday, Fluda, Hallisey, Mingalay, Watersey, &c.,—and is estimated to contain 4000 acres of arable land, and 18,000 of meadow and hill pasture. The cod, ling, and herring fisheries are considerable; and the coasts abound with shell-fish, especially cockles, which have sometimes afforded food to the inhabitants in times of famine. On Barra Head, the highest point of Berneray, is a lighthouse with an intermitting light 680 feet above high water, in lat. 56° 48' N., long. 7° 38' W. There are several remains of interest in the island of Barra, as the churches at Kilbar, the castle of the McNeils at Kishmul, "Danish" forts and "Druidical" circles. Population of island (chiefly Gaelic-speaking Roman Catholics) in 1871, 1563; of the parish, 1753.

**BARRACKPUR**, a magisterial subdivision and town of British India, in the district of 24 Parganas, under the Lieutenant-Governor of Bengal. Barrackpur SUBDIVISION was formed in 1858. It consists of the single police circle of Nawabganj, and contains an area of 42 square miles, with 51 villages, 16,067 houses, and a total population of 68,629, of whom 47,709, or 69·5 per cent., are Hindus; 19,600, or 28·6 per cent., are Mahometans; 1281, or 1·9 per cent., are Christians; and 39 are of other religions. Proportion of males to total population, 52·2 per cent.; persons per square mile, 1626; villages per square mile, 1·21; persons per village, 1346; houses per square mile, 380; persons per house, 4·3. In 1870-71 the subdivision contained one magistrate's court, with a regular police of 195, and a village watch of 38 men. The separate cost of administration amounted to £2101.

**BARRACKPUR TOWN** and **CANTONMENT**, situated on the H. rl, 15 miles above Calcutta, in 22° 45' 40" N. lat., and 88° 23' 52" E. long.; area, 889 acres, or 1·39 square miles. Population, according to the experimental census of 1869—males, 5730; females, 2914; total, 8644. Population, as ascertained by the general census of 1872:—Hindus—males, 3207; females, 1745; total, 4952; Mahometans—males, 1987; females, 1561; total, 3548; Christians—males, 766; females, 297; total, 1063; others—males, 21; females, 7; total, 28. Total of all denominations—males, 5981; females, 3610; total in 1872, 9591. Municipal income in 1872, £235, 9s. 6d.; expenditure, the same; taxation, 5½d. per head. Major Smyth says in his *Survey Report of the 24 Parganas District (1867)*:—"The natives call it 'Chának,' from the circumstance of Job Charnock, the founder of Calcutta, having erected a bungalow and established a small bazar there [in 1689]. Troops were first stationed there in 1772, from which time it has acquired the name of Barrackpur. The cantonment is situated on the left bank of the Húgúí; it has also a large bazar and several large tanks, and also a parade ground.

There are usually four regiments of Native infantry cantoned in the lines. To the south of the cantonment is situated the park, created by the taste and public spirit of Lord Wellesley. Within the park is situated the Government House, a noble-looking building, commenced by Lord Minto, and enlarged into its present state by the Marquis of Hastings. The park is beautifully laid out, and contains a small menagerie." Its most interesting feature is now Lady Canning's tomb. Within the last few years commodious two-storied brick barracks have been constructed for the British troops, and have materially added to the health and comfort of the soldiers. The military bazar is situated a short distance from the Sepoy lines, and is carefully supervised by the authorities. The military force stationed in the cantonment, on the 1st March 1873, was as follows:—English troops, 18 officers, and 395 non-commissioned officers and rank and file; Native, 12 English and 21 Native officers, with 877 non-commissioned officers and men; total of all ranks, European and Native, 1323.

Barrackpur played an important part in the two Sepoy mutinies of 1824 and 1857, but the details of these belong to the general history of British rule in India.

**BARRACKS** are groups of buildings constructed for the accommodation of soldiers. The word, which was formerly spelt "baracks" or "baragues," is derived from the Spanish "barracas," meaning the little huts or cabins used by the fishermen on the sea-shore, or for soldiers in the field. The French call them "casernes," meaning lodgings for soldiers. Barracks of a temporary character, commonly called "huts," have ordinarily been constructed by troops on a campaign as winter quarters, or when for any length of time in "standing camp,"—they being accommodated when in the field under other circumstances in tents, or else, if not provided with tents, bivouacning without cover.

In times of peace barracks were formerly only provided for troops in fortified places termed "garrisons," soldiers elsewhere being provided with quarters by being billeted on public-houses. The apprehension of disturbances, and risk of the troops being too much mixed up with the populations of the localities in which they might be stationed, mainly led to the construction of barracks in or near towns in England about the year 1792. In the first instance the Deputy-adjutant-general was charged with the building and fitting up of barracks. In 1793 the same officer was appointed "Superintendent-general of barracks," and subsequently "Barrack-master-general." In 1806 the barrack establishment was placed under the direction of a board of four commissioners, of whom one was generally a military man. About the year 1825 the duke of Wellington arranged for the construction and maintenance of barracks to be given over to the corps of Royal Engineers. The custody and equipment of barracks, with the supply of fuel and light to the troops quartered in them, were then made and remained, until recently, the duty of the "barrack department," which consisted of barrack-masters and barrack-sergeants.

The duties connected with barracks in the British service are now arranged as follows:—

- |   |  |
|---|--|
| Construction, maintenance, and supply of fixtures; also custody if dismantled.....                            | } Royal Engineer Department.   |
| Equipment with supplies of all kinds, giving and taking over; also custody when furnished but unoccupied..... |  |
|   | } Commissariat Department.   |
|   | } Q. M. General's Department, under the orders of head-quarters of the Field-Marshal Commanding-in-Chief, and in districts or at foreign stations of the General Officer Commanding. |

Distribution of troops to barracks

The duties connected with the construction of barracks are under the supervision of the Inspector-general of Fortifications, who is also Director of Works to the War Department. He is assisted in these duties by a Deputy and two Assistant-directors of Works, and a professional staff.

The arrangement and composition of barracks vary according to the arm of the service to be accommodated in them; thus for the cavalry, horse and field artillery, Royal Engineer train, and transport branch of the army service corps, stables are required; and it is usual to provide for the unmarried non-commissioned officers and men over their horses, a troop of cavalry or a division of field artillery being placed in a separate block of two stories in height. Horse and field artillery also require gunsheds and workshops for artificers, such as collarmakers, wheelers, &c. All mounted troops require forge and shoeing accommodation as well as saddlers' shops. Garrison artillery and companies of Royal Engineers can be accommodated in similar barracks to those for infantry, but the latter require an ample provision of workshops for artificers, with store accommodation for materials, &c.

Not fifty years since, in the West Indies, men slept in barracks in hammocks touching each other, only 23 inches of lateral space being allowed for each man. At the same time in England the men slept in wooden beds, with two tiers, like the berths of a ship, and not unfrequently each bed held four men. Now, each soldier has an iron bedstead which turns up in the middle, forming a seat for the day-time, and only two rows of beds are allowed in barrack-rooms, and the principle of providing one window for every two beds is carried out in all new barracks.

The best size for a barrack-room is now considered to be 60 or 62 feet long, by 20 feet wide, and about 12 feet high. The number of men each room is to contain is painted on the door; and in barracks of modern construction each barrack-room has attached to it—

(L.) A small (single) sergeant's room, with fire-place, cupboard, and small window looking into the men's room.

(A.) An ablution room, with basins, water-taps, and a fixed pan in which the feet can be washed.

(U.) A night urinal, with water for flushing laid on.

Barracks are washed once a week, and on intermediate days the rooms are dry-scrubbed. The walls and ceilings are limewashed by the troops twice a year. The general periodical painting of all barrack buildings is performed twice externally and once internally in every eight years. Formerly, barrack buildings were placed on very limited areas, and even a whole regiment was lodged in one house built in the form of a square, with the quarters of the officers on one side for the better supervision of the men; but the Barrack and Hospital Improvement Commission recommended that the men should be divided in numerous detached buildings, so placed as to impede as little as possible the movement of air and the action of the sun's rays.

For barracks, as a general rule, buildings of two stories in height are preferred to those of three stories, but three-story buildings may be adopted where space is limited and land very costly. Buildings of two stories are less expensive than those of only one story in height, and the general arrangement, when the former mode of construction is adopted, is more compact. The selection of a site for a barrack requires great care and circumspection. This duty is performed in the first instance by the Commanding Royal Engineer of the district, or an officer appointed by him; but the ground proposed is also reported on by an Army medical officer as well as subsequently by the General Officer commanding the district, the final approval resting with the Secretary of State for War.

The following important points have to be considered in the selection of a site, viz. —(1.) That the ground is suitably situated; (2.) That it is sufficient for the number and nature of troops to be placed in the barracks; (3.) That it is not commanded by higher ground within range of rifle fire; (4.) That the subsoil is good and healthy; (5.) That water can be easily obtained for drinking, washing, and cooking; (6.) That drainage and sewerage can be carried out; (7.) That gas can be laid on.

A barrack should not as a rule be placed in the midst of a populous town, nor should it be too far distant from one. If in the midst of a town it would not be likely to be healthy or well placed in respect to keeping up discipline; if too far off the men quartered in it may become dissatisfied with the service. A barrack should be surrounded with a defensible wall; there should be as few entrances as possible, and these should be provided with strong, well-barred gates.

In the new barracks now under construction for brigade depôts, the armouries are generally placed in defensible "keeps," the outer or boundary walls being flanked by *caponnières*. In arranging the position of buildings on a design for a barrack, the axis of each of those intended for occupation by troops should be north and south, so as to allow the sun's rays to fall on both sides. One building should in no case obstruct the light from another. The distance of buildings should not be less than their own height from each other. The position selected for any new building or buildings in an existing or a proposed barrack is reported on by a board of officers, consisting of the head of the department, officer commanding a regiment, or other responsible officer who is to occupy the building when erected, an officer not under the rank of captain, and the commanding Royal Engineer or other engineer officer, a medical officer attending to advise the board. On the completion of a new building or barrack, it is also reported on by a board of officers before being taken over for occupation.

In 1854–55 public attention was called to the necessity for sanitary improvement in the barracks belonging to Great Britain, and an inquiry was instituted by the Barrack and Hospital Improvement Commission, which was succeeded by the Army Sanitary Committee. The result of the inquiries so made has been a great improvement of the quarters of the troops, which has tended largely to decrease the sickness previously prevalent among them.

The principal improvements have been as follows, viz. —At least 600 cubic feet, and from 50 to 60 superficial feet, are now allotted to every single non-commissioned officer and man in permanent barracks, it being considered as important that a soldier should have his full ration of air as of food. In wooden huts 400 cubic feet are reckoned sufficient. At least 1000 cubic feet are allotted to every single non-commissioned officer and man in hot climates. About 1600 cubic feet are allotted to every horse, and since the introduction of ventilation, as well as proper sanitary arrangements in stables, glanders have almost entirely disappeared from the army. Married non-commissioned officers and men have special accommodation, with one or two rooms each, according to the size of the rooms or rank of the occupant. In the latest buildings small washing-rooms have been provided, in addition to two rooms for each family. A laundry and infant school are provided for every compound of married soldiers' quarters. The principal medical officer is now charged with seeing that the regulations for protecting the health of troops in barracks are carried out. Each regimental medical officer has also to see to this matter, as well as that every soldier has a separate bed; that the beds are placed at a proper distance from the wall, and are well aired; and that the windows are opened every morning. Barrack-rooms are warmed in two ways, viz., by radiant heat from an open fire, and by warm air obtained from an air chamber behind, and heated by the fire. Much attention has been paid of late years to the improvement of the means of cooking the meals of soldiers. Either steel boilers and Deane's ovens or "Warren's" apparatus are now ordinarily provided for this purpose. Every headquarter barrack now has a gymnasium and also a chapel school, as well as a sergeants' mess establishment. Besides a canteen with

a separate bar for the sale of groceries, one room is provided for recreation, with a coffee bar attached, and another room for reading, with a small book-room attached to it, where the library is stored, and from which books are issued. Where there are several barracks at the same station, the sick are usually treated in a garrison hospital; but where there is only one barrack, a regimental hospital forms a part of it. 1200 cubic feet are allowed at home for each patient treated in military hospitals, and about 1800 cubic feet in those constructed in hot climates. The proportion of hospital accommodation now allowed at home stations is 6 per cent. on the accommodation of the barrack or barracks to which such hospital is attached. A surgery, store accommodation, a separate infection ward, hospital sergeant's quarters, sick-orderly's rooms, and a mortuary, are provided as part of an hospital establishment. There is also, whenever practicable, a garden, where the convalescents can sit out, or take exercise in fine weather. At the main entrance to every barrack a regimental guard-room is placed, which, besides a good room for the guard, provided with a wooden bed on an iron frame, contains a prisoners' room, and also a few separate cells for the detention of such prisoners as require to be kept apart. A proportion of "provost cells" are also constructed in large barracks, where soldiers are confined when ordered or sentenced to imprisonment for short periods. In headquarter cavalry barracks a riding school, ordinarily 150 feet long and 50 feet wide, is provided; also one or more maneges for out-door training. In smaller barracks, for mounted troops only, maneges are provided for equitation exercise. Rifle ranges are now considered to be necessary adjuncts to all except small barracks, but sometimes the troops have to be moved to a distance for this purpose, owing to local difficulties preventing practice being carried on. In barracks of modern construction, a separate house or quarter containing about six rooms is provided for a commanding officer, and two rooms with a kitchen (or servant's room) for each field officer, or officer holding relative rank as such, and for each quarter-master. Other officers have one room each, with a compartment screened or curtained off for sleeping and dressing, a servant's room for brushing and cleaning being provided for every two or three officers. A mess establishment is attached to every officers' barrack, which is constructed in proportion to the numbers to be quartered in the barracks. Where the headquarters of a regiment are stationed, a billiard-room is usually allowed as part of the mess establishment. A good supply of water is one of the first requisites in a barrack, and it is preferable to obtain it, if possible, from the water-works of the locality, rather than from wells, which are liable to become polluted from soakage, leakage of drains, or other causes. Barracks should have high-level tanks, to contain one or two days' supply of water, as a reserve, or in case of fire, and fire-cocks should be fixed in suitable places. Fire-engines, with an ample supply of hose and also ladders, are always supplied for use in barracks. The sewers or drains of a barrack should, if possible, discharge into the main or branch sewers of the locality, but if none such exist, irrigation of land may be resorted to, or earth closets can be adopted, and the liquid drainage only be disposed of by irrigation, or such other means as may be practicable. All drains should be properly trapped and ventilated. Soil-pipes of water-closets should also be ventilated by means of small pipes carried up above the roof of the main building; pipes of the size of ordinary gas-pipes will suffice for this purpose, allowing the escape of foul gas into the outer air. Overflow or other water-pipes should on no account be connected directly with a drain, but should discharge into an open or surface channel, or over a trap or grating. Gas is ordinarily laid on to barracks both externally and internally, the quantity consumed being checked by a meter or meters. It is usually obtained by agreement from any public gas-works in the locality, but at certain large stations the War Department have their own gas-works. At certain large stations where large bodies of troops are quartered, churches are provided in addition to or in place of chapel schools. The latter are used for the services of the men of different persuasions in succession; the former are sometimes similarly used, but are more generally restricted to the Church of England or other specific religious persuasion. Sometimes military cemeteries are provided, but more generally the soldiers are buried in those of the localities where they may be quartered. Wherever there is sufficient ground about or near a barrack, as at Eastney, near Portsmouth, soldiers may have portions for gardening allotted them.

The funds for the construction and maintenance of barracks are included in Vote 13 of the army estimates, and the average amounts so provided for them during the past three years have been as follows:—

Part 1, Works over £1000 .....	£102,198
Part 2, New works and alterations under £1000 .....	68,040
Part 3, Ordinary and current repairs .....	210,455
	£380,693

The funds for the equipment of barracks are provided

in Vote 12, for the departmental staff in Vote 9, and for supplies of fuel and light in Vote 10 of the army estimates. (c. r. r.)

**BARRAS, PAUL FRANÇOIS JEAN NICOLAS, COMTE DE**, a distinguished actor in the great French Revolution, was born in June 1755. He was a descendant of a noble family in Provence, and at an early age entered the army. He was twice in India with his regiment, but retired from the service after attaining the rank of captain. Like many others, he saw in the Revolution a good opportunity for retrieving his fortunes, which had been ruined by his extravagance and dissipation; and his penetration enabled him to foresee the certain fall of the royalist party. He threw in his lot with the revolutionists, and speedily distinguished himself by his vigour and hardihood. When elected a member of the National Convention, he gave an uncompromising vote for the king's death; and at the siege of Toulon, where for the first time he met Napoleon, his energetic measures contributed much to the success of the French arms. Robespierre, who hated Barras for his dissolute habits, and feared him for his boldness, endeavoured to have his name included in one of his proscription lists, but, on the 9th Thermidor 1794 Barras completely overthrew his power. His success from this period was secured; after the 13th Vendémiaire 1795, he was nominated general-in-chief; and after the affair of the 18th Fructidor 1797, in which Angereau played a prominent part, he was practically dictator. Bonaparte's *coup d'état* of the 18th Brumaire 1799 changed the whole aspect of affairs. Barras, seeing that resistance to his powerful protégé was useless, gave in his resignation, and retired to his country seat. His latter years were spent in various intrigues, in which he showed a strong leaning towards the royalist party. He died in 1829. The character of Barras has little in it that is worthy of admiration. He was dissolute in private life, and can scarcely be said to have had any definite public policy. At the same time he was courageous, prudent, and, on occasions, an able speaker.

**BARRHEAD**, a town of Scotland, county of Renfrew, three miles S. of Paisley, and 8 miles S.W. of Glasgow on the Caledonian Railway line between that city and Kilmarnock. It has rapidly increased since about 1840, and formed a junction with the neighbouring villages of Dovecot-hall, Cross Artherlie, and Grahamston. The principal employment is spinning, weaving, and bleaching. Population in 1871, 6209.

**BARRI, GERALD DE**, commonly called *Giraldus Cambrensis*, an historian and ecclesiastic of the 12th and 13th centuries, was born at the castle of Maenor Pyrr near Pembroke, probably in 1147. By his mother he was descended from the princes of South Wales, and the De Barris were one of the most powerful Welsh families. Being a younger brother, and intended for the church, he was sent to St David's, and educated in the family of his uncle, the bishop of that see. When about twenty years of age he was sent to the University of Paris, where he continued for some years, and, according to his own account, became an excellent rhetorician and lecturer. On his return in 1172 he entered holy orders, and was made archdeacon of Brecknock. Having observed with much concern that his countrymen the Welsh were very backward in paying tithes of wool and cheese, he applied to Richard, archbishop of Canterbury, and was appointed his legate in Wales for remedying this and other disorders. Barry excommunicated all, without distinction, who refused to compound matters with the church, and, in particular, delivered over bodily to the evil one those who withheld the tithes. Not satisfied with enriching, he also attempted to reform the clergy. He deleted an aged archdeacon to the archbishop, for the unpardonable crime of matrimony;

and on his refusing to put away his wife he was deprived of his archdeaconry, which was bestowed upon the zealous legat. On the death of his uncle, the bishop of St David's, in 1176, he was elected his successor by the chapter; but this choice having been made without the permission and against the will of Henry II., Gerald prudently declined to insist upon it, and went again to Paris to prosecute his studies. He speaks with exultation of the prodigious fame which he acquired by his eloquent declamations in the schools, and of the crowded audiences who attended them. Having spent about four years at Paris, he returned to St David's, where he found everything in confusion; and on the temporary retirement of the bishop, which took place soon after, he was appointed administrator by the advice of the archbishop of Canterbury, and governed the diocese in that capacity till 1184, when the bishop was restored. About the same time he was called to court by Henry II., appointed one of his chaplains, and sent into Ireland with Prince John, by whom he was offered the united bishoprics of Fernes and Leighlin. He would not accept them, and employed his time in collecting materials for his *Topography of Ireland*, and his history of the conquest of that island, which was completed in three books in 1187. In 1188 he attended Baldwin, archbishop of Canterbury, in his progress through Wales, preaching a crusade for the recovery of the Holy Land,—an employment in which he tells us, with his usual modesty, that he was far more successful than the primate, adding significantly, that the people were most affected with Latin sermons (which they did not understand), melting into tears, and coming in crowds to take the cross. On the accession of Richard I. in 1189, he was sent by that monarch into Wales to preserve the peace of the country, and was even joined in commission with William Longchamp, bishop of Ely, as one of the regents of the kingdom. He failed, however, to improve this favourable opportunity; and having fixed his heart on the see of St David's, the bishop of which was very old and infirm, he refused the bishopric of Bangor in 1190, and that of Llandaff the year following. But in 1192 the state of public affairs became so unfavourable to Barri's interest at court that he determined to retire. He proceeded to Lincoln, where William de Monte read lectures in theology with great applause; and here he spent about six years in the study of divinity, and in composing several works. At last the see of St David's, which had long been the object of his ambition, became vacant, and he was unanimously elected by the chapter, but met with so powerful an adversary in Hubert, archbishop of Canterbury, that it involved him in a litigation which lasted five years, cost him three journeys to Rome, and ended in his defeat in the year 1203. Retiring from the world, he spent the last seventeen years of his life in studious privacy. His MSS. are preserved in the British Museum, the library at Lambeth, and the Bodleian Library.

Of his published works, the best known is his *Itinerarium Cambrie*, of which a translation, illustrated with annotations, and accompanied with a life of the author, was published by Sir Richard Colt Hoare, in two splendid quarto volumes, in 1806. The complete works are being published under the direction of the Master of the Rolls, with full introductions.—*Gerald's Cambrian Opera*, edited by J. B. Brewer and Mr Dimock, 6 vols., 1861-75; the seventh and last volume has not yet appeared.

**BARRINGTON; JOHN SHUTE, FIRST VISCOUNT**, a nobleman distinguished for theological learning, was the youngest son of Benjamin Shute, merchant, and was born at Theobald, in Hertfordshire, in 1678. He received part of his education at the University of Utrecht; and, after returning to England, studied law in the Inner Temple. In 1701 he published several pamphlets in favour of the civil rights of Protestant dissenters, to which class he belonged. On the

recommendation of Lord Somers, he was employed to induce the Presbyterians in Scotland to favour the union of the two kingdoms, and in 1708 he was rewarded for this service by being appointed to the office of commissioner of the customs. From this, however, he was removed on the change of administration in 1711; but his fortune had, in the meantime, been improved by the bequest of two considerable estates,—one of them left him by Francis Barrington of Tofts, whose name he assumed by Act of Parliament, the other by John Wildman of Becket. Barrington now stood at the head of the dissenters. On the accession of George I. he was returned member of parliament for Berwick-upon-Tweed; and in 1720 the king raised him to the Irish peerage, by the title of Viscount Barrington of Ardglass. But having unfortunately engaged in the Harburg lottery, one of the bubble speculations of the time, he incurred the disgrace of expulsion from the House of Commons in 1723,—a punishment which was considered greatly too severe, and was thought to be due to personal malice on the part of Walpole. In 1725 he published his principal work, entitled *Miscellanea Sacra, or a New Method of considering so much of the History of the Apostles as is contained in Scripture, in an Abstract of their History, an Abstract of that Abstract, and four Critical Essays*, 2 vols. 8vo,—afterwards reprinted with additions and corrections, in 3 vols. 8vo, 1770, by his son, the bishop of Durham. In the same year he published *An Essay on the Several Dispensations of God to Mankind*. He was the author of various other tracts, chiefly on subjects relating to religious toleration. He died in 1784. Of his large family four were distinguished.

The eldest, **WILLIAM WILDMAN**, second Viscount Barrington (born 1717, died 1793), held important Government offices. From 1755 to 1761 he was secretary at war, from 1761 to 1762 chancellor of the exchequer, from 1762 to 1765 treasurer of the navy, and from 1765 to 1778 secretary at war again. He resigned in that year, receiving a handsome pension. In 1782 he held office for a short time as postmaster-general.

The Hon. **DAINES BARRINGTON**, the third son, born in 1727, was a distinguished antiquary and naturalist. He was educated for the profession of the law, and after filling various posts, was appointed a Welsh judge in 1757, and afterwards second justice of Chester. He never rose to much eminence at the bar, but he showed his knowledge of the law as a subject of liberal study by a valuable publication, entitled *Observations on the Statutes, chiefly the more ancient, from Magna Charta to 21st James I. cap. 27, with an Appendix, being a proposal for new-modelling the Statutes*, 1766, 4to, a work which has a high reputation among historians and constitutional antiquaries. In 1773 he published an edition of Orosius, with Alfred's Saxon version, and an English translation with original notes. His *Tracts on the Probability of reaching the North Pole*, 1775, 4to, were written in consequence of the northern voyage of discovery undertaken by Captain Phipps, afterwards Lord Mulgrave. In them he has accumulated a variety of evidence favourable to his own opinion of the practicability of attaining the object in which that voyage had failed; and it is not improbable that his views and arguments had some effect in determining the Government at a later period to renew the attempt. Mr Barrington's other writings are chiefly to be found in the publications of the Royal and Antiquarian Societies, of both of which he was long an assiduous member, and of the latter vice-president. Many of these were collected by him in a quarto volume entitled *Miscellanies on various Subjects*, 1781. Among the most curious and ingenious of his papers, are his *Experiments and Observations on the Singing of Birds* and his *Essay on the Language of Birds*. He

died on the 14th March 1800, and was buried in the Temple church.

SAMUEL BARRINGTON, the fourth son, was born in 1729, and died in 1800. He entered the navy at an early age, and in 1747 had worked his way to a post-captaincy. He was distinguished for his bravery and skill, and in 1778 attained the rank of rear-admiral. He held command for some time in the West Indies, and repulsed a superior French force at Sta Lucia.

SHUTE BARRINGTON, the youngest son, was born in 1734, and died in 1826. He was educated at Eton and Oxford, and after holding some minor dignities, was made bishop of Llandaff in 1769. In 1782 he was translated to Salisbury, and in 1791 to Durham. He published several volumes of sermons and tracts, and wrote the political life of his brother, Viscount Barrington.

BARISTERS, in England, are the highest class of lawyers who have exclusive audience in all the superior courts. Every barrister must be a member of one of the four ancient societies called Inns of Court, viz., Lincoln's Inn, the Inner and Middle Temples, and Gray's Inn. The existence of these societies as schools can be traced back to the 13th century, and their rise is attributed to the clause in Magna Charta, by which the Common Pleas were fixed at Westminster instead of following the king's court, and the professors of law were consequently brought together in London. Associations of lawyers acquired houses of their own in which students were educated in the common law, and the degrees of barrister (corresponding to apprentice or bachelor) and sergeant (corresponding to doctor) were conferred. These schools of law are now represented by the Inns of Court, which still enjoy the exclusive privilege of calling to the bar, and through their superior order of *benchers* control the discipline of the profession.

Every person not otherwise disqualified may be admitted as a student of law by passing a general examination in London, or on producing evidence of his having passed a public examination at a university. The year is divided into four terms, and every student must keep twelve terms before he can be called to the bar. A term is kept by the student's dining six (if a university man, three) times in the hall of his society. Until quite recently the Inns of Court exercised little or no supervision over the legal education of their students. Any student who had duly kept his terms might be admitted to the bar on producing either a certificate of having passed the general examination of the Council of Legal Education, or a certificate of attendance at certain public lectures, or of having read in the chambers of a barrister or special pleader for at least twelve months. The examination not being compulsory, was only used as a qualification for call by a minority of students, and neither of the other tests afforded any security as to the applicant's fitness for admission. The regulations both as to legal education and examinations have been very greatly altered. A complete staff of public lecturers and tutors has been established, and every student must pass an examination in jurisprudence, civil and international law, and English law, before being admitted to his call. Persons connected with the law in any inferior capacity (such as that of solicitor and solicitor's clerk), or with trade, will not be admitted as students; and the benchers, besides, have the right of rejecting any applicant with or without cause assigned. For sufficient reasons, and subject to an appeal to the Common Law judges as visitors, they may reject the petition of a student to be called to the bar, or expel from their society and from the profession any barrister or bencher of the inn. This power has been exercised in several cases within recent years, and the benchers appear to take cognizance of any kind of miscon-

duct, whether occurring in the course of professional practice or not, which they may deem unworthy of the rank of barrister.

The peculiar business of barristers is the advocacy of causes in open court, but in England a great deal of other business falls into their hands. They are the chief conveyancers, and the *pleaders* (i.e., the counter statements of parties previous to joining issue) are in all but the simplest cases drafted by them. There is, indeed, a separate class of *conveyancers* and *special pleaders*, being persons who have kept the necessary number of terms qualifying for a call, but who, instead of being called, take out licences to practise *under the bar*. There are still a few persons who act under such special licences, but in general conveyancing and special pleading form part of the ordinary work of a junior barrister. The highest rank among barristers is that of king's or queen's counsel. They lead the case in court, and give opinions on cases submitted to them, but they do not accept conveyancing or pleading, nor do they admit pupils to their chambers. Precedence among queen's counsel, as well as among outer barristers, is determined by seniority. The order of sergeants at law still exists, but no new appointments have recently been made, and it will probably be allowed to become extinct, the title of queen's counsel being generally preferred. Sergeants rank after queen's counsel. Although every barrister has a right to practise in any court in England, it will be found, in fact, that each special class of business has its own practitioners, so much so indeed, that the bar may almost be said to be divided into several professions. The most marked distinction is that between barristers practising in Chancery and barristers practising in the courts of Common Law. The fusion of Law and Equity contemplated by the Judicature Act, 1873, may be expected in course of time to break down this distinction; but for many years there has been a complete separation between these two great branches of the profession. There are also subordinate distinctions in each branch. Counsel at Common Law attach themselves to one or other of the circuits into which England is divided, and may not practise elsewhere unless under special conditions. In Chancery the queen's counsel for the most part restrict themselves to one or other of the courts of first instance (those of the Vice-Chancellors or Master of the Rolls). Business before the court of Admiralty, the court of Probate and Divorce, the Privy Council, and parliamentary committees, exhibits, though in a less degree, the same tendency to specialization. In some of the larger provincial towns there are now local bars of considerable strength. In Manchester and Liverpool alone there are believed to be between seventy and eighty practising barristers; and the probable extension of this system cannot fail to have a most important influence on the future character of the profession. The bar of Ireland exhibits in its general arrangements the same features as the bar of England. Every Irish barrister must have kept at least six terms in one of the English Inns of Court. There is no connection whatever between the Scotch and English bars.

Counsel is not answerable for anything spoken by him relative to the cause in hand and suggested in the client's instructions, even though it should reflect on the character of another and prove absolutely groundless, but if he mention an untruth of his own invention, or even upon instructions if it be impertinent to the matter in hand, he is then liable to an action from the party injured. Counsel may also be punished by the summary power of the court or judge as for a contempt, and by the benchers of the inn to which he may belong on cause shown.

The rank of barrister is a necessary qualification for nearly all offices of a judicial character, and a very usual

qualification for other important appointments. Not only the judgeships in the Superior Courts of Law and Equity at home and in the colonies, but nearly all the magistracies of minor rank—recorderships, county court judgeships, &c.,—are restricted to the bar. The result is a unique feature in the English system of justice, viz., the perfect harmony of opinion and interest between the bar as a profession and all degrees of the judicial bench.

*Revising Barristers* are counsel of not less than seven years' standing appointed to revise the lists of parliamentary voters.

Barristers cannot maintain an action for their fees, which are regarded as gratuities, nor can they, by the usage of the profession, undertake a case without the intervention of an attorney.

**BARROS, JOAO DE**, a celebrated Portuguese historian, was born about 1496, and died in 1570. In 1522 he was appointed governor of St George del Mina, on the coast of Guinea. Three years after, the king recalled him to court, and made him treasurer of the Indies. This appointment furnished him with the materials necessary for the composition of his valuable history, entitled *Asia Portuguesa*, the first decade of which he published in 1552, the second in 1553, and the third in 1563; the fourth was not published till 1615. Several authors have continued the work, so that it extends to twelve decades. The best edition is that published at Lisbon, in 1778, in 9 vols. 8vo.

**BARROW-IN-FURNESS**, a borough, port, and parish in the hundred of Lonsdale, North-West Lancashire, situated opposite the island of Walney, at the extreme point of the peninsula of Furness, which lies between Morecambe Bay and the estuary of the Duddon. It is distant 35 miles from Lancaster and 91 from Carlisle. The area of the borough, which includes Walney and the islets at its south end, is 17,000 acres, of which 8155 are land, the rest being sand and water.

The town has had a remarkable rise. The veins of pure hematite iron ore in the district, now so extensively wrought, have long been in repute; and more than a hundred years ago, a small traffic was carried on in the ore, with the addition by-and-by of pig-iron, which early began to be manufactured in the vicinity of the mines,—the branch of the channel, now converted into docks, serving as a harbour, and the beach as a quay, for the shipment of the material brought down from the mines and charcoal furnaces. But at the beginning of the present century the annual export was only about 1000 tons, and then, and for many years after, though the trade went on increasing, the place was the merest hamlet, the population so recently as 1847 being only 325. It may be said that the railway has created the modern town. By the opening in 1846 of the first short section of the Furness Company's line, from the mines near Dalton to Piel pier and Barrow, the trade of the district received a great impetus, and it rapidly developed with the various extensions of the railway, till in 1857, by the carrying of the line over Morecambe sands, through communication was established between Barrow and Carnforth. When the railway was opened the shipments of ore had risen to 60,000 tons a year, while within five years afterwards there left by sea and rail a total of 250,000 which again, within other five years, increased to 450,000 tons. The next great onward step was the establishment at Barrow, in 1859, of the iron-works of Messrs Schneider and Hannay, followed in 1864 by the commencement of steel-works, the two being united in 1866 under "The Barrow Hematite Steel Company (Limited)." In 1867 there were opened the Devonshire and Buccleuch docks, constructed at a comparatively small cost by the enclosure of the channel between the mainland and a small island on which shipbuilding works have since been

erected. The docks comprise an area of above 60 acres, are entered from Walney Channel by a gateway 60 feet wide, give a uniform depth of 24 feet, the stone quays being  $1\frac{1}{2}$  miles long, and the wharves supplied with hydraulic cranes, one of which is capable of lifting 100 tons. Within a few years after the opening of the docks various important branches of industry were introduced, by means of which the town has both been consolidated and increased. The census of 1871 gives a return of 17,992, while a census for municipal purposes, November 1874, showed a population of over 40,000. The inhabited houses at the same period numbered about 6000, the rateable value of the borough being £144,000. The town owes much of its prosperity to the enterprise of the dukes of Devonshire and Buccleuch, and also to the foresight, zeal, and practical ability of Sir James Ramsden, managing director of the Furness Railway Company and first mayor of the borough, who in 1872 received the honour of knighthood as an acknowledgement of the value of his work, while a massive bronze statue in the centre of the town, raised about the same time by voluntary contributions, testifies to the appreciation of his services by the community.

A great part of the town lies low, much of it being built on ground reclaimed from the sea. It is well laid out, according to a fixed plan, in regular streets running at right angles, viz., north and south, and east and west. About £19,000 have already been expended on approaches and general road improvements. Not many public buildings can be looked for, but among others are the North Lonsdale Hospital; the Workmen's Club and Institute, the gift of Mr H. W. Schneider, and others; swimming baths, presented by Sir James Ramsden; a town-hall and large covered market, besides churches, schools, and banks.

The first place among the public works must be assigned to those of the Barrow Hematite Steel Company. Their iron-works have sixteen blast furnaces constructed so as to save the waste gases, which are utilized in heating the boilers and hot-air ovens. At the steel-works, which are the largest in Great Britain, are eighteen converters for making Bessemer steel. The amount of ore used is about 460,000 tons annually, of which the company's own mines yield upwards of 350,000 tons. There is an annual produce of 250,000 tons pig-iron, and 110,000 tons of steel, 80,000 tons of the latter being rails. In the processes about 500,000 tons of coke and coal are consumed annually; and the company employ at their works and iron-mines nearly 5000 men, besides a large number at coal-mines which they also work.

The works of the Iron Shipbuilding Company (capital, a quarter of a million), lying between the docks and Walney Channel, cover an area of 50 acres, with a frontage of 1050 feet, where ten vessels of the largest size can be laid down. When the works are in full operation, 6000 men will be employed. There is also a graving-dock of the largest size.

The Barrow Flax and Jute Company have an extensive jute work adjoining the docks, and communicating with the railway. It covers an area of 14 acres, has an imposing and attractive exterior, and is beautifully and elaborately fitted up with the greatest possible regard to efficiency and comfort. The works employ 2000 hands. Besides the above there are large engineering-works, waggon-works, saw-mills, brick-works, and a steam corn-mill.

The trade of the port is indicated by the character of the public works. The imports are chiefly timber, coal, jute, and general produce. Ore, steel rails, and pig-iron are chief among the exports. In 1874 the vessels entering the port numbered 1620, with a tonnage of 347,800 tons register. An extension of dock accommodation is being provided in a series of basins, to be called the Ramsden dock, with a water area of 300 acres. Passenger

steamers run daily to Belfast, and there is also a regular service to Glasgow and to the Isle of Man. By rail there is connection with Whitehaven, and with the London and North-Western and Midland systems, with branches to the Lake district.

Barrow is in the diocese of Carlisle. Besides the Church of England, which has three places of worship, there are the following churches:—the Presbyterian, Congregational, Wesleyan, Methodist New Connexion, Baptist, and Primitive Methodist.

The town received a charter of incorporation in 1867, when a council of sixteen was nominated, that number being doubled by an Act obtained in 1875. The supply of water comes from Kirkby Moor, the water-works as well as the gas-works being the property of the corporation. A cemetery has been provided at a cost of £25,000, with three chapels. A complete and thorough plan of drainage is being carried out, partly on the separate system. There is a fire brigade under the corporation, and at the entrance to the harbour there is a life-boat station. The police are those of the county. Several newspapers are published; and there are branches of various banking establishments, some of them occupying large and handsome buildings.

The extensive and interesting ruins of Furness Abbey, founded by Stephen in 1127, lie within the borough, over two miles from the heart of the town. They are beautifully situated in a small wooded valley, with a hotel and railway station close by. On Piel island is the Pile of Fouldrey, or Piel castle, the ruin of a castle built in 1327 by the abbot of Furness.

BARROW, ISAAC, an eminent mathematician and divine, was the son of Thomas Barrow, a linen draper in London, where he was born in 1630. He was at first placed for two or three years at the Charter-house school. There, however, his conduct gave but little hopes of his ever succeeding as a scholar, for he was inattentive and extremely fond of fighting. But after his removal from this establishment, his disposition took a happier turn; and having soon made considerable progress in learning, he was in 1643 entered at St Peter's College, and afterwards at Trinity College, Cambridge, where he applied himself with great diligence to the study of literature and science, especially of natural philosophy. He at first intended to adopt the medical profession, and made some progress in anatomy, botany, and chemistry, after which he studied chronology, geometry, and astronomy. He then travelled in France and Italy, and in a voyage from Leghorn to Smyrna gave proofs of great personal bravery; for the ship having been attacked by an Algerine pirate, Barrow remained upon deck, and fought with the utmost intrepidity, until the pirate, unprepared for the stout resistance made by the ship, sheered off and left her to pursue her voyage.

At Smyrna he met with a most kind reception from the English consul, Mr Bretton, upon whose death he afterwards wrote a Latin elegy. From this place he proceeded to Constantinople, where he received similar civilities from Sir Thomas Bendish, the English ambassador, and Sir Jonathan Dawes, with whom he afterwards contracted an intimate friendship. While at Constantinople he read and studied the works of Chrysostom, once bishop of that see, whom he preferred to all the other Fathers. He resided in Turkey somewhat more than a year, after which he proceeded to Venice, and thence returned home through Germany and Holland in 1659. Immediately on his reaching England he received ordination from Bishop Brownrigg, and in 1660 he was appointed to the Greek professorship at Cambridge. When he entered upon this office he intended to have prelected upon the tragedies of Sophocles; but he altered his intention, and made choice of Aristotle's rhetoric. His lectures on this subject having

been lent to a friend who never returned them, are irrecoverably lost. In July 1662 he was elected professor of geometry in Gresham College, on the recommendation of Dr Wilkins, master of Trinity College, and afterwards bishop of Chester; and in May 1663 he was chosen a fellow of the Royal Society, at the first election made by the council after obtaining their charter. The same year the executors of Mr Lucas, who, according to the terms of his will, had founded a mathematical chair at Cambridge, fixed upon Barrow as the first professor; and although his two professorships were not inconsistent with each other, he chose to resign that of Gresham College, which he did on the 20th May 1664. In 1669 he resigned his mathematical chair to his illustrious pupil Isaac Newton, having now determined to renounce the study of mathematics for that of divinity. Upon quitting his professorship Barrow was only a fellow of Trinity College; but his uncle gave him a small sinecure in Wales, and Dr Seth Ward, bishop of Salisbury, conferred upon him a prebend in that church. In the year 1670 he was created doctor in divinity by mandate; and, upon the promotion of Dr Pearson, master of Trinity College, to the see of Chester, he was appointed to succeed him by the king's patent, bearing date the 13th February 1672. In 1675 Dr Barrow was chosen vice-chancellor of the university. He died on the 4th of May 1677, in the 47th year of his age, and was interred in Westminster Abbey, where a monument, surmounted by his bust, was soon after erected by the contributions of his friends. By his English contemporaries Barrow was considered a mathematician second only to Newton. Continental writers do not place him so high, and their judgment is probably the more correct one. He was undoubtedly a clear-sighted and able mathematician, who handled admirably the severe geometrical method, and who in his *Method of Tangents* approximated to the course of reasoning by which Newton was afterwards led to the doctrine of Ultimate Ratios; but his substantial contributions to the science are of no great importance, and his lectures upon elementary principles do not throw much light on the difficulties surrounding the border-land between mathematics and philosophy. His *Sermons* have long enjoyed a high reputation; they are weighty pieces of reasoning, elaborate in construction and ponderous in style.

His scientific works are very numerous. The most important are—1. *Euclid's Elements*; 2. *Euclid's Data*; 3. *Optical Lectures*, read in the public school of Cambridge; 4. *Thirteen Geometrical Lectures*; 5. *The Works of Archimedes, the Four Books of Apollonius's Conic Sections, and Theodosius's Spherics, explained in a New Method*; 6. *A Lecture*, in which Archimedes's Theorems of the Sphere and Cylinder are investigated and briefly demonstrated; 7. *Mathematical Lectures*, read in the public schools of the University of Cambridge. The above were all written in Latin. His English works have been collected and published in four volumes folio.

BARROW, SIR JOHN, Bart., was born near Ulverston, in Lancashire, June 19, 1764. His early opportunities of instruction were limited; but by self-education he matured those powers which eventually were turned to so good an account. He displayed at an early age a decided inclination for mathematical pursuits. He passed some years of his youth as superintending clerk of an iron foundry at Liverpool, and he afterwards taught mathematics at an academy in Greenwich. While in the latter situation he was fortunate in obtaining, through the interest of Sir George Staunton, a place in the first British embassy to China. He was thus enabled to put his foot on the first step of the ladder of ambition; but each step in his subsequent career may be fairly said to have been achieved by himself. The account of the embassy published by Sir George Staunton records many of Barrow's valuable contributions to literature and science connected with China. This work, together with his own subsequently published volume of



travels, is ample evidence how well his time had been employed. Few persons could, within the space of a few months, overcome all the practical difficulties of such a language as the Chinese; but Barrow soon began to converse in it, and acquired a complete knowledge of its theory. His papers on this subject in the *Quarterly Review* (to which periodical he was for many years a very frequent contributor) contain a very admirable account of that singular language.

Although Barrow ceased to be personally connected with Chinese affairs after the return of the embassy in 1794, he always continued to take a lively interest in them, and on critical occasions was frequently consulted by the British Government. His services were secured by Lord Macartney in his important and delicate mission to settle the government of the newly-acquired colony of the Cape of Good Hope. Barrow was entrusted with opening communications with the Kaffres, in which he displayed a spirit, judgment, and humanity, which unfortunately were less conspicuous in subsequent transactions with those tribes. The two volumes of his history of the colony made the public fully acquainted with the extent, capacities, and resources of that important, but till then little understood, acquisition of the British Crown. There is little doubt that it was the perusal of this valuable work which mainly decided Lord Melville to appoint Barrow, though then a perfect stranger to him, as his second secretary of the Admiralty. Barrow's subsequent career for forty years at the Admiralty (embracing the whole period of the war with France), will be for ever historically associated with the civil administration of the British navy for the same period. He enjoyed the esteem and confidence of all the eleven chief lords who successively presided at the Admiralty Board during that period, and more especially of King William IV., while lord high admiral, who honoured him with tokens of his personal regard. Barrow was a fellow of the Royal Society, and had the degree of LL.D. The honour of a baronetcy was conferred on him by Sir Robert Peel in 1835; the letter in which the honour was announced acknowledged, in highly gratifying terms, his literary and scientific eminence, and his "long, most able, and most faithful public service."

Besides the works already mentioned, Barrow published the lives of Lord Macartney, Lord Anson, Lord Howe, and Peter the Great; and he was also the author of several valuable contributions to the seventh edition of the *Encyclopædia Britannica*.

He retired from public life in 1845, in consideration of his advanced years, although still in vigorous possession of all the mental and bodily powers required for the due discharge of the functions of his office. In the course of the three following years his vital energies gradually declined, but he nevertheless continued so fully in the enjoyment of his faculties, writing a history of the modern Arctic voyages of discovery, of which he was a great promoter, as well as his autobiography, published in 1847, that his friends and relatives entertained no apprehension that his end was so near. He expired suddenly on the 23d November 1848, in the 85th year of his age, much honoured and respected by his friends and the public at large.

**BARROWS.** The custom of constructing barrows, or mounds of stones or earth, over the remains of the dead was the most characteristic feature of the sepulchral systems of primitive times. Originating in the common sentiment of humanity, which desires by some visible memorial to honour and perpetuate the memory of the dead, it was practised alike by nations of high and of low development, and continued through all the stages of culture that preceded the introduction of Christianity. The primary idea of sepulture appears to have been the

provision of a habitation for the dead; and thus, in its perfect form, the barrow included a chamber or chambers where the tenant was surrounded with all the prized possessions of his previous life. A common feature of the earlier barrows is the enclosing fence, which marked off the site from the surrounding ground. When the barrow was of earth, this was usually effected by an encircling trench or a low *esplanade*. When the barrow was a stone structure, the enclosure was usually a circle of standing stones. Sometimes, instead of a chamber formed above ground, the barrow covered a pit excavated under the original surface, in which the interments had been made. In later times the mound itself was frequently dispensed with, and the interments made under the natural surface, within the enclosure of a trench, a *vallum*, or a circle of standing stones. Usually the great barrows occupy conspicuous sites; but in general the external form is no index to the internal construction, and gives no absolute indication of the nature of the sepulchral usages. Thus, while the long barrow is characteristic of the Stone Age, it is impossible to tell without direct examination whether it may be chambered or unchambered, or whether the burials within it may be those of burnt or of unburnt bodies.

In England the long barrow usually contains a single chamber, entering by a passage underneath the higher and wider end of the mound. In Denmark the chambers are at irregular intervals along the body of the mound, and have no passages leading into them. The long barrows of Great Britain are often from 200 to 400 feet in length by 60 to 80 feet wide. Their chambers are rudely but strongly built, with dome-shaped roofs, formed by overlapping the successive courses of the upper part of the side walls. In Scandinavia, on the other hand, such dome-roofed chambers are unknown, and the construction of the chambers as a rule is megalithic, five or six monoliths supporting a capstone of enormous size. Such chambers denuded of the covering mound, or over which no covering mound has been raised, are popularly known in England as "cromlechs" and in France as "dolmens." The prevailing mode of sepulture in all the different varieties of these structures is by the deposit of the body in a contracted position, accompanied by weapons and implements of stone, occasionally by ornaments of gold, jet, or amber. Vessels of clay, more or less ornate in character, which occur with these early interments of unburnt bodies, are regarded as food vessels and drinking cups, differing in character and purpose from the cinerary urns of the Cremation Period in which the ashes of the dead were deposited.

The custom of burning the body commenced in the Stone Age before the long barrow or the cromlech, with their contracted burials, had passed out of use. While cremation is rare in the long barrows of the south of England, it is the rule in those of Yorkshire and the north of Scotland. In Ireland, where the long barrow form is all but unknown, the round barrow, or chambered cairn, prevailed from the earliest Pagan period till the introduction of Christianity. The Irish barrows occur in groups in certain localities, which seem to have been the royal cemeteries of the tribal confederacies, whereof eight are enumerated in an ancient Celtic manuscript on Pagan cemeteries. The best known of these was the burial-place of the kings of Tara. It is situated on the banks of the Boyne above Drogheda, and consists of a group of the largest cairns in Ireland. One of these, at New-Grange, is a huge mound of stones and earth, over 300 feet in diameter at the base, and 70 feet in height. Around its base are the remains of a circle of large standing stones. The chamber, which is 20 feet high in the centre, is reached by a passage 70 feet in length. (See illustration, vol. ii. p. 384.)

As in the case of the long barrows, the traditional form

of the circular chambered barrows was retained through various changes in the sepulchral customs of the people, and we find it used both in connection with burnt and with unburnt burials. It was the natural result of the practice of cremation, however, that it should induce a modification of the barrow structure. The chamber, no longer regarded as a habitation to be tenanted by the deceased, became simply a cist for the reception of the urn which held his ashes. The degradation of the chamber naturally produced a corresponding degradation of the mound which covered it, and the barrows of the Bronze Age, in which cremation was the rule, are smaller and less imposing than those of the Stone Age, but often surprisingly rich in the relics of the life and of the art workmanship of the time. In addition to the varied and beautiful forms of implements and weapons,—frequently ornamented with a high degree of artistic taste,—armlets, coronets, or diadems of solid gold, and vases of elegant form and ornamentation in gold and bronze, are not uncommon. The barrows of the Bronze Period, like some of those of the Stone Age, appear to have been used as tribal or family cemeteries. In Denmark as many as seventy deposits of burnt interments have been observed in a single mound, indicating its use as a burying-place throughout a long succession of years.

In the early Iron Age there was a partial return to the more massive construction of the earlier periods. Sometimes chambers are found formed of timber instead of stones, in which the bodies were deposited unburnt, although the custom of cremation was largely continued. In Scandinavia both of these modes of sepulture lingered till the close of the Pagan time. One of the latest examples of the great timber-chambered barrow is that at Jellinge in Jutland, known as the barrow of Thyre Danebod, queen of King Gorm the Old, who died about the middle of the 10th century. It is a mound about 200 feet in diameter, and over 50 feet in height, containing a chamber 23 feet long, 8 feet wide, and 5 feet high, formed of massive slabs of oak. Though it had been entered and plundered in the Middle Ages, a few relics, overlooked by its original violators, were found when it was recently reopened, among which were a silver cup, ornamented with the interlacing work characteristic of the time, and some personal ornaments. It is highly illustrative of the tenacity with which the ancient sepulchral usages were retained even after the introduction of Christianity that King Harald, son and successor of Gorm the Old, who is said to have Christianized all Denmark and Norway, followed the Pagan custom of erecting a chambered tumulus over the remains of his father, on the summit of which was placed a rude pillar-stone, bearing on one side the memorial inscription in Runes, and on the other a representation of the Saviour of mankind distinguished by the crossed nimbus surrounding the head. The Kings' Hows at Upsala in Sweden rival those of Jellinge in size and height. In the chamber of one of them, which was opened in 1829, there was found an urn full of calcined bones; and along with it were some ornaments of gold showing the characteristic workmanship of the 5th and 6th centuries of the Christian era. Along with the calcined human bones were bones of animals, among which those of the horse and the dog were distinguished. In much earlier times the favourite horse or dog of the deceased was frequently deposited in Etruscan tombs, and the custom continued in Northern Europe until cremation, and the barbarous rites which usually accompanied it, were abolished by the stringent prohibitions of the Christian church.

Comparing the results of the researches in European barrows with such notices of barrow-burial as may be gleaned from early writings, we find them mutually illustrative.

The Homeric account of the building of the barrow of Hector (*Iliad*, xxiv.) brings vividly before us the scene so often suggested by the examination of the tumuli of pre-historic times. During nine days wood was collected and brought, in carts drawn by oxen, to the site of the funeral pyre. Then the pyre was built and the body laid upon it. After burning for twenty-four hours the smouldering embers were extinguished with libations of wine. The white and calcined bones were then picked out of the ashes by the friends and placed in a metallic urn, which was deposited in a hollow grave, or cist, and covered over with large well-fitting stones. Finally, a barrow of great magnitude was heaped over the remains, and the funeral feast was celebrated. The obsequies of Achilles, as described in the *Odyssey*, were also celebrated with details which are strikingly similar to those observed in tumuli both of the Bronze and Iron Ages. The body was brought to the pile in an embroidered robe, and jars of unguents and honey were placed beside it. Sheep and oxen were slaughtered at the pile. The incinerated bones were collected from the ashes and placed in a golden urn along with those of Patroclus, Achilles's dearest friend. Over the remains a great and shapely mound was raised on the high headland, so that it might be seen from afar by future generations of men.

Herodotus, describing the funeral customs of the Scythians, states that, on the death of a chief, the body was placed upon a couch in a chamber sunk in the earth and covered with timber, in which were deposited all things needful for the comfort of the deceased in the other world. One of his wives was strangled and laid beside him, his cup-bearer and other attendants, his charioteer, and his horses, were killed and placed in the tomb, which was then filled up with earth, and an enormous mound raised high over all. The barrows which cover the plains of ancient Scythia attest the truth of this description. A Siberian barrow, described by Demidoff, contained three contiguous chambers of unhewn stones. In the central chamber lay the skeleton of the ancient chief, with his sword, his spear, his bow, and a quiver full of arrows. The skeleton reclined upon a sheet of pure gold, extending the whole length of the body, which had been wrapped in a mantle brodered with gold and studded with precious stones. Over it was extended another sheet of pure gold. In a smaller chamber at the chief's head lay the skeleton of a female, richly attired, extended upon a sheet of pure gold, and similarly covered with a sheet of the same metal. A golden chain adorned her neck, and her arms were encircled with bracelets of pure gold. In a third chamber, at the chief's feet, lay the skeleton of his favourite horse with saddle, bridle, and stirrups.

So curiously alike in their general features were the sepulchral usages connected with barrow-burial over the whole of Europe, that we find the Anglo-Saxon Saga of Beowulf describing the chambered tumulus with its gigantic masonry "held fast on props with vaults of stone," and the passage under the mound haunted by a dragon, the guardian of the treasures of heathen gold which it contained. Beowulf's own burial is minutely described in terms which have a strong resemblance to the parallel passages in the *Iliad* and *Odyssey*. There is first the preparation of the pile, which is hung round with helmets, shields, and coats of mail. Then the corpse is brought and laid in the midst; the pile is kindled, and the roaring flame rises, mingled with weeping, till all is consumed. Then, for ten long days, the warriors labour at the raising of his mighty mound on the headland, high and broad, to be seen afar by the passers by on land and sea.

The pyramids of Egypt, the mausolea of the Lydian kings, the sepulchres of the Atreidae at Mycenæ, and the Etruscan tombs at Cerv and Volci, are lineally descended

from the chambered barrows of prehistoric times, modified in construction according to the advancement of architectural art at the period of their erection. There is no country in Europe destitute of more or less abundant proofs of the almost universal prevalence of barrow-burial in early times. It can be traced on both sides of the basin of the Mediterranean, in Northern Africa, and in Asia Minor, across the plains of Mesopotamia, in the valley of Cabal, and throughout Western India. But more extended research in the archaeology of these vast regions is needed to enable us to correlate their ancient remains with those of the European continent.

In the New World as well as in the Old, the same customs prevailed over vast areas from a very remote period. In the great plains of North America the dead were buried in barrows of enormous magnitude, which occasionally present a remarkable similarity to the long barrows of Great Britain. In these mounds cremation appears more frequently than inhumation; and both are accompanied by implements, weapons, and ornaments of stone and bone. The pottery accompanying the remains is often elaborately ornamented, and the mound builders were evidently possessed of a higher development of taste and skill than is evinced by any of the modern aboriginal races, by whom the mounds and their contents are regarded as utterly mysterious.

It is not to be wondered at that customs so widely spread and so deeply rooted as those connected with barrow-burial should have been difficult to eradicate. In fact, compliance with the Christian practice of inhumation in the cemeteries sanctioned by the church, was only enforced in Europe by capital laws denouncing the punishment of death on those who persisted in burying their dead after the Pagan fashion or in the Pagan mounds. Yet even in the Middle Ages kings were buried with their swords and spears, and queens with their spindles and ornaments; the bishop was laid in his grave with his crozier and comb, his chalice and vestments; and clay vessels filled with charcoal (answering to the urns of heathen times) are found with the interments in the churches of France and Denmark.

See Bateman, *Ten-Years' Diggings*; Davis and Thurnam, *Orania Britannica*; Thurnam, "Ancient British Barrows," in *Archæologia*; Canon Greenwell, Dr Angus Smith, and J. Anderson, "On Cairns in Argyre and Caithness," in *Proceedings of the Society of Antiquaries of Scotland*; Petrie, *Histories and Antiquities of Towns, and Round Towers of Ireland*; Wormae's *Antiquities of Denmark*, translated by Thoms; Nicolayson, *Norve's Fornlevninger*; Montelius, *La Suède Préhistorique*; Cochet, *La Normandie Souterraine*; Squier and Davis, *Ancient Monuments of the Mississippi Valley*; Stevens, *Plant Objects*; Ferguson, *Stone Monuments of all Countries*. (J. AN.)

**BARROW'S STRAITS**, a portion of the channel which runs W. from Baffin's Bay through the islands of the Arctic archipelago to Melville Sound. It lies between 73° 45' and 74° 40' N. lat., is about 200 miles in length, and has an average breadth of 60 or 70 miles. In many places it is upwards of 200 fathoms in depth. The coasts on both sides are generally steep and rugged, with numerous bays and inlets, the most important of which is the Prince Regent Inlet, which runs E. into the Gulf of Boothia.

**BARRY, SIR CHARLES**, a distinguished English architect, was born at Westminster, May 23, 1795. After pursuing his elementary professional studies for six years as apprentice to a firm of architects at Lambeth, he set out, in 1817, on the customary foreign tour, visiting Greece and Italy, Egypt and Palestine, and enriching his memory and imagination by the study of the great buildings and remains of former ages. On his return to England in 1820 he settled in London, and was not slow in attaining distinction. One of the first works by which his abilities as an architect became generally known was the church of St Peter at Brighton,—an attempt in Perpendicular Gothic,

completed in 1826. He built many other churches; but the marked preference for Italian architecture, which he acquired during his travels, showed itself in various important undertakings of his earlier years. In 1831 he erected the Travellers' Club in Pall Mall, a splendid work in the Italian style, and the first of its kind built in London. In the same style and on a grander scale, he erected, some years later, the Reform Club. It is unnecessary to particularise the numerous private mansions on which he was engaged, one of the latest and most magnificent of which was Bridgewater House, the town residence of the earl of Ellesmere. Birmingham possesses one of his best works in the buildings of King Edward's grammar school, in the Tudor style. For Manchester he designed the Athenæum, in the Italian style; and for Halifax, the town-hall. He was engaged for some years in reconstructing the Treasury buildings, Whitehall. But his masterpiece, and perhaps, notwithstanding all unfavourable criticism, the masterpiece of English architecture of the 19th century, is the new palace at Westminster. After the destruction of the old houses of parliament by fire in October 1834, Barry was the successful competitor for erecting the new palace. The first stone was laid in the spring of 1840; the work was steadily carried on in the face of many difficulties, and through a maze of private dissensions and public complaints, and it was at length completed in 1860. Twenty years seemed long in passing, but once past the time assuredly will no more seem too long to have been employed in the erection, or, we might say, allowed for the growth of this stately and beautiful pile, one of the truest glories of the banks of the Thames. Barry was elected A.R.A. in 1840, and R.A. in the following year. His genius and achievements were recognized by the representative artistic bodies of the principal European nations; and his name was enrolled as a member of the academies of art at Rome, Berlin, St Petersburg, Brussels, and Stockholm. He was chosen F.R.S. in 1849, and was knighted by the Queen in 1852. He died suddenly at Clapham, near London, May 12, 1860, and his remains were interred in Westminster Abbey. In 1867 appeared a life of Sir Charles Barry by his son, Dr Alfred Barry, principal of King's College, London. A claim was thereupon set up on behalf of Mr A. Welby Pugin deceased, who had been Barry's assistant, to a much larger share in the work of designing this Westminster Palace than was admitted in Dr Barry's narrative. The controversy raged for a time, but without substantiating Mr Pugin's claim.

**BARRY, JAMES**, an eminent painter, was born at Cork on the 11th October 1741. His father had been a builder, and, at one time of his life, a coasting trader between the two countries of England and Ireland. To this business of trader James was destined, and he actually made, when a boy, several voyages; but these being forced upon him, he on one occasion ran away from the ship, and on all others manifested such an aversion to the life and habits of a sailor, as to induce his father to relinquish all hopes of him in this line, and to suffer him to pursue his inclinations, which led strongly towards drawing and study. At the schools in Cork to which he was sent, he was distinguished above his school-fellows by his talents and industry; his habits differed from those of ordinary boys; he seldom mixed in their games or amusements, but during play-hours stole off to his own room, where he worked at his pencil, or studied some book that he had borrowed or bought. As his industry was excessive, his advances in the acquisition of knowledge were rapid, and he was regarded as a prodigy by his school-fellows. About the age of seventeen he first attempted oil painting, and between that and the age of twenty-two, when he first went to Dublin, he produced several large pictures, which decorated his father's house,

and represented subjects not often chosen by young artists, such as *Aeneas* escaping with his family from the flames of Troy, *Susanna* and the elders, *Daniel* in the lions' den, &c. At this period he also produced the painting which first brought him into public notice, and gained him the acquaintance and patronage of Edmund Burke. The picture was founded on an old tradition of the landing of St Patrick on the sea-coast of Cashel, and of the conversion and baptism of the king of that district by the patron saint of Ireland. Barry's manner of treating it was such as to gain for him the applause and admiration of the connoisseurs of London, where it was exhibited in 1762 or 1763.

By the liberality of Burke and his other friends, Barry, in the latter part of 1765, was enabled to proceed to the Continent, where he remained till the beginning of 1771, studying his art with an enthusiasm which seemed to augur the highest success, and making observations on the different *chef's d'œuvre* of Italy with equal independence of judgment and nicety of discrimination. He proceeded first to Paris, then to Rome, where he remained upwards of three years, from Rome to Florence and Bologna, and thence home through Venice. His letters to the Burkes, giving an account of Michel Angelo, Raffaella, Titian, and Leonardo da Vinci, show a complete insight into the characteristic merits of their works, and would make us wonder (if the case were at all singular) how he could enter with such force, delicacy, and feeling, into excellences of which he transplanted nothing into his own works.

Even in copying from the antique he manifested the same aversion to labour, or to that kind of labour which, by showing us our defects, compels us to make exertions to remedy them. He made all his drawings from the antique by means of a *delineator*, that is, a mechanical instrument, to save the trouble of acquiring a knowledge both of form and proportion. Barry painted two pictures while abroad, his *Adam* and *Eve*, and his *Philoctetes*. The first of these he sent home as a specimen of his progress in the art. It does not appear to have given much satisfaction. His *Philoctetes* he brought home with him. It is a coarse, unclassical performance,—the direct opposite, indeed, of all that he thought it to be. Soon after his return to England he produced his picture of *Venus*, which has been compared, though with little justice, to the *Galatea* of Raffaella, the *Venus* of Titian, and the *Venus de Medici*. In 1773 he exhibited his *Jupiter* and *Juno* on Mount Ida, which was much praised by some critics of that day. His *Death of General Wolfe*, in which the British and French soldiers are represented in very primitive costumes, was considered as a falling off from his great style of art, the painting of Greek subjects, and, accordingly, it is said to "have obtained no praise." His fondness for Greek costume was assigned by his admirers as the cause of his reluctance to paint portraits,—as if the coat were of more importance than the face. His fastidiousness in this respect, and his frequent excuses or blunt refusals to go on with a portrait of Burke which he had begun, caused a misunderstanding with his early patron, which does not appear to have been ever entirely made up. The difference between them is said to have been widened by Burke's growing intimacy with Sir Joshua Reynolds, and by Barry's feeling some little jealousy of the fame and fortune of his rival "in a humbler walk of the art." About the same time he painted a pair of classical subjects, *Mercury* inventing the lyre, and *Narcissus* looking at himself in the water, the last suggested to him by Burke. He also painted an historical picture of *Chiron* and *Achilles*, and another of the story of *Stratonice*, for which last the duke of Richmond gave him a hundred guineas. In 1773 it was proposed to decorate the interior of St Paul's with historical and sacred subjects; but the plan fell to the

ground, from not meeting with the concurrence of the bishop of London and the archbishop of Canterbury. Barry was much mortified at the failure, for he had in anticipation fixed upon the subject he intended to paint,—the rejection of Christ by the Jews when Pilate proposes his release. In 1773 he published *An Inquiry into the real and imaginary Obstructions to the Acquisition of the Arts in England*, vindicating the capacity of the English for the fine arts, and tracing their slow progress hitherto to the Reformation, to political and civil dissensions, and, lastly, to the general direction of the public mind to mechanics, manufactures, and commerce. In the year 1774 a proposal was made, through Mr Valentine Green, to Reynolds, West, Cipriani, Barry, and other artists, to ornament the great room of the Society for the Encouragement of Arts, Manufacturers, and Commerce, in the Adelphi, with historical and allegorical paintings. This proposal was at the time rejected by the artists themselves; but, in 1777, Barry made an offer to paint the whole on condition of being allowed the choice of his subjects, and being paid by the society the expenses of canvas, paints, and models. His offer was accepted, and he finished the series of pictures at the end of seven years, instead of two, as he had proposed to himself, accomplishing his task to the entire satisfaction of the members of the society, who granted him two exhibitions, and at different periods voted him 50 guineas, their gold medal, and 200 guineas. Of the six paintings making up the series, only one, that of the Olympic Games, shows any artistic power.

Soon after his return from the Continent Barry had been chosen a member of the Royal Academy; and in 1782 he was appointed professor of painting, in the room of Mr Panny, with a salary of £30 a year. The lectures which he delivered from the chair were full of strong sense and wholesome advice, both to the students and academicians. Among other things, he insisted much on the necessity of purchasing a collection of pictures by the best masters as models for the students, and proposed several of those in the Orleans collection. This recommendation was not relished by the academicians, and quarrels arose, which reached such a height, that, in 1799, Barry was expelled from the academy, soon after the appearance of his *Letter to the Dilettanti Society*, a very amusing but eccentric publication, full of enthusiasm for his art and at the same time of contempt for the living professors of it. After the loss of his salary, a subscription was set on foot by the earl of Buchan to relieve him from his difficulties, and to settle him in a larger house to finish his picture of *Pandora*. The subscription amounted to £1000, with which an annuity was bought, but of this he was prevented from enjoying the benefit, for, on the 6th of February 1806, he was seized with a pleuritic fever, and died on the 22d of the same month. On the 14th of March his remains were interred in the cathedral of St Paul's.

As an artist Barry is more distinguished for the strength of his conceptions, and for his resolute and persistent determination to apply himself only to great subjects, than for his skill in designing or for beauty in his colouring. His ideas were generally fine, but the realization of them was almost without exception unsuccessful. His drawing is rarely good, his colouring frequently wretched. This curious contradiction in his artistic powers was in complete harmony with his general character. He was extremely impulsive and unequal; sometimes morose, sometimes sociable and urbane; jealous of his contemporaries, and yet capable of pronouncing a splendid eulogy on Reynolds.

BARB, a province of Hungary, in the district watered by the Neutra, Gran, and Zsitva, which belong to the northern part of the system of the Danube. It is for the most part mountainous and has great mineral wealth.

especially in gold and silver. The most remarkable mines are those of Skleno and Vihnya. The chief towns are Kremnitz or Kőrömcz Bánya, and Neuschl or Besztercebánya. Population in 1869, 137,191, mostly Roman Catholics.

**BARTAN**, a town in Asiatic Turkey, situated near the mouth of the Bartan-su, which was known to the Greeks as the *Parthenius*, and formed part of the boundary between Bithynia and Paphlagonia. The town is built on two low limestone hills, and has its streets paved with blocks of that material. It carries on a considerable trade with Constantinople, which might be increased were it not for the obstruction of the harbour by a bar. Population between six and seven thousand.

**BARTAS**, GUILLAUME DE SALLUSTE DU, a French poet, was born in 1544, and died in 1590 of wounds received in the battle of Ivry. He was employed by Henry IV. of France in England, Denmark, and Scotland; and he commanded a troop of horse in Gascony, under the Marshal de Martingan. His principal work, *La Sepmaine*, a poem on the creation of the world, which has long since fallen into oblivion, once enjoyed a high reputation, thirty editions of it having been printed within six years after its appearance. Its religious tone and rather fanciful style made it a great favourite with English writers of the time, by whom the author was always designated as the divine Du Bartas, and placed on an equality with Ariosto. Spenser, Hall, and Ben Jonson, all speak in the highest terms of what seems to us a most uninteresting poem. King James VI. tried his "prentice hand" at the translation of Du Bartas's poem *L'Uranie*, and the compliment was returned by the French writer translating, as *La Lépante*, the monarch's poem on the battle of Lepanto. Joahna Sylvester, one of the Spenserian poets, translated the *Sepmaine* in 1598, and the work in its English form was extremely popular and exercised no slight influence on English literature. Du Bartas published a second *Week* in 1584; portions of it and of the first were translated by Th. Hudson, William Lisle, and Thomas Winter.

**BARTFELD**, or **BÁRTFA**, a town of Hungary, county of Saros, on the River Tople. It has some trade in wine, corn, linen and woollen goods, paper, &c., and is noted for the mineral springs in the vicinity, the water of which is largely exported. Its Gothic church is adorned with numerous artistic treasures, and its archives are rich in ancient documents. Population, 5808.

**BARTH**, HENRIKON, a distinguished African explorer, was born at Hamburg, February 16, 1821. At the age of eighteen he went to Berlin, and completed his education at the university of that city. After a year of study he set out to travel in Italy and Sicily, returning to Berlin in 1841, and continuing his studies for three years. He took his degree in 1844, and yielding to a desire, which had long possessed him, to explore the countries lying on the Mediterranean, he made his first visit to North Africa in 1845. Before setting out he had visited London and Paris, and made himself acquainted with the Arabic language. He reached Tunis, Tripolis, Benghazi, explored Cyrenaica, and travelled down the valley of the Nile. On his return journey he was attacked and wounded by robbers. In 1847 he travelled in Egypt and Palestine, and in Asia Minor and the islands off its coasts, and from Constantinople returned through Greece to Berlin. For a time he was engaged there as *Privat-docent*, and in preparing for publication the narrative of his *Wanderungen durch die Küstenländer des Mittelmeeres*, which appeared in 1849. At the suggestion of Bunsen and Ritter he entered with enthusiasm into the project of the English expedition for the exploration of Central Africa, and set out with Overweg in November 1849. Five years were devoted to their

explorations, and Barth did not arrive in Europe till September 1855. His account, entitled *Reise und Entdeckungen in Nord- und Centralafrika*, appeared in 5 vols., between 1855 and 1858, and was followed by a collection of Central African vocabularies (1862-64). Dr Barth had not yet exhausted his energies as a traveller. In 1858 he undertook another journey in Asia Minor, and in 1863 visited Turkey in Europe. In the following year, having returned to Berlin, he was appointed professor of geography at the university, and president of the Geographical Society. He died at Berlin, November 25, 1865.

**BARTH**, or **BART**, JEM, son of a fisherman of Dunkirk, was born in 1661 and died in 1702. He served, when young, in the Dutch navy, but when war broke out between Louis XIV. and Holland, he entered the French service. He gained great distinction in the Mediterranean, where he held an irregular sort of commission, not being then able from his low birth to receive a command in the navy. His success was so great, however, that he was made a lieutenant. He rose rapidly to the rank of captain, and then to that of admiral. The peace of Byswick put a close to his active service. Many anecdotes are narrated of the courage and bluntness of the uncultivated sailor, who became the popular hero of the French naval service. (Richer, *Vie de Jean Bart*, 1780, and many editions since; Vanderest, *Histoire de Jean Bart*.)

**BARTHÉLEMY**, AUGUSTE MARSEILLE, a French satirical poet, was born at Marseilles in 1796, and died in 1867. After having established some local reputation as a poet he went to Paris, where by one of his first efforts, *Le Sacre de Charles X.*, 1825, he gained the favour of the court. His energies, however, were soon enlisted in the service of the opposition party. In 1826 appeared the clever political satire, *Le Villiade*, a mock heroic poem, the joint production of Barthélemy and his constant friend Méry, also a native of Marseilles. The success was immediate and pronounced; fifteen editions were called for during the year, and the authors cleared nearly £1000. A rapid succession of political squibs and satires was now poured forth by the authors, one of the most remarkable being *Napoléon en Egypte*, 1828, which passed through nearly a dozen editions in a year. In 1829 Barthélemy had become so offensive to the Government that he was imprisoned and fined 1000 francs. The Revolution of 1830 liberated him; and in company with Méry, he celebrated the triumph of the people in one of their most brilliant efforts, *L'Insurrection*. During the next two years Barthélemy, though enjoying for a time a pension from Louis Philippe, did not cease his attacks on the Government and its ministers. In 1832, however, he made a curious change, the motive for which is not clear, but the effect of which was seriously to impair, almost to destroy his influence. In that year he published an anonymous poem, supporting some acts of the Government which were peculiarly obnoxious to the Liberal party, and, on the work being attacked, defended it openly. For the next few years he enjoyed a handsome pension from the Government, and refrained from all satirical writing. He again resumed his old style in 1844, but without the former success. From that date he contented himself with merely occasional poems.

**BARTHÉLEMY**, JEAN JACQUES, a celebrated French writer, was born on the 20th January 1716, at Cassis, a little seaport on the shores of the Mediterranean. He was educated, first at the college of the Oratory in Marseilles, and afterwards at that of the Jesuits in the same city. While completing the course of study requisite for the church, which he intended to join, he devoted much attention to Oriental languages, in which he became very proficient. After assuming the ecclesiastical habit, he

resided with his family at Antibes, and during this period of his life was introduced by his friend, M. Cary of Marseilles, to the study of classical antiquities, particularly in the department of numismatics. In 1744 he repaired to Paris, carrying with him a letter of introduction to M. Gros de Boze, perpetual secretary of the Academy of Inscriptions and Belles Letters, and keeper of the medals. He became assistant to De Boze, and on the death of the latter in 1753, was appointed his successor. In the following year he was enabled to pay a visit to Italy, and spent some time in that country, inspecting its rich treasures of classical remains. While on his journey he made the acquaintance of the French ambassador, M. de Stainville, afterwards duc de Choiseul, and of his wife. The minister conceived a great regard for Barthélemy, and on his accession to power loaded the scholar with benefits. In 1759 he gave him a pension on the archbishopric of Albi; in 1765 he conferred on him the treasurership of St Martin de Tours, and, in 1768, made him secretary-general to the Swiss guards. In addition to these sources of revenue, the abbé enjoyed a pension of 5000 livres on the *Mercure de France*. His income, which was thus considerable, was well employed by him; he supported and established in life three nephews, and gave largely to indigent men of letters. In 1789, after the publication of his great work, he was elected a member of the French Academy, one of the highest honours to which a French author aspires. During the troubled years of the Revolution, Barthélemy, from his position and habits, took no share in any public affairs. Yet he was informed against and arrested as an aristocrat. So great, however, was the respect felt for his character and talents, that the Committee of Public Safety were no sooner informed of the arrest, than they gave orders for his immediate release. Barthélemy died soon after, on the 30th April 1795.

The great work on which Barthélemy's fame rests appeared in 1788, and was entitled *Voyage du jeune Anacharsis en Grèce, dans le milieu du quatrième siècle avant l'ère Chrétienne*. He had begun it in 1787, and, during an uninterrupted succession of thirty years, occupied his leisure hours in bringing it to maturity. The hero, a young Scythian, descended from the famous philosopher Anacharsis, whose name he bears, is supposed to repair to Greece for instruction in his early youth, and after making the tour of her republics, colonies, and islands, to return to his native country and write this book in his old age, after the Macedonian hero had overturned the Persian empire. In the manner of modern travellers, he gives an account of the customs, government, and antiquities of the country he is supposed to have visited; a copious introduction supplies whatever may be wanting in respect to historical details; whilst various dissertations on the music of the Greeks, on the literature of the Athenians, and on the economy, pursuits, ruling passions, manners, and customs, of the surrounding states, supply ample information on the subjects of which they treat. The author, indeed, is not profound; and the young Scythian seldom penetrates much below the surface. But his remarks are commonly judicious, and to considerable erudition he unites singular skill in the distribution of his materials, and a happy talent for presenting his subject in the most agreeable and attractive form. The assumed character is so admirably sustained throughout, that we can scarcely persuade ourselves we are not perusing a book of real travels, and communing with an actual personage who has recorded his observations and experiences for the instruction and improvement of his countrymen. Modern scholarship has superseded most of the details in the *Voyage*, but the author himself did not imagine his book to be a register of accurately ascertained facts; he rather intended to afford to his countrymen, in an interesting form, some knowledge of Greek civilisation. The *Charities of Becker* is a more recent attempt in a similar direction, but, though superior in scholarship, it wants the charm of style which is the principal quality in the *Anacharsis*.

BARTHEZ, or BARTHEAS, PAUL JOSEPH, one of the most celebrated physicians of France, was born on the 11th of December 1734, at Montpellier. He received his early education at Narbonne and Toulouse, and soon gave decisive indications of the great talents with which nature had endowed him. He commenced the study of medicine at Montpellier in 1750, and in 1753, when he had only at-

tained his nineteenth year, he received his doctor's degree. He afterwards occasionally visited Paris, where he attracted the notice and acquired the friendship of the most distinguished literati of the period. In 1756 he obtained the appointment of physician to the military hospital in Normandy attached to the army of observation commanded by Marshal d'Estrées. A severe attack of hospital fever compelled him to leave this post; but the numerous cases which had come under his notice furnished materials for several papers contributed to the *Memoirs of the Academy of Sciences*. In 1757 his services were required in the medical staff of the army of Westphalia, where he had the rank of consulting physician. After his return to Paris he acted for some time as joint editor of the *Journal des Savans* and the *Encyclopédie Méthodique*. In 1761 he obtained a medical professorship at Montpellier, in which his abilities as a teacher soon shone forth with unrivalled lustre. His success was the more honourable, inasmuch as his colleagues—Lamure, Leroy, and Venel—were men of distinguished reputation, and had raised the school to a high pitch of celebrity.

In 1774 he was created joint chancellor of the university, with the certainty of succeeding singly to the office on the death of the colleague, which happened in 1786. He afterwards took the degree of doctor in civil law, and was appointed counsellor to the Supreme Court of Aids at Montpellier. In 1780 he was induced to fix his residence in Paris, having been nominated consulting physician to the king, with a brevet of counsellor of state, and a pension of a hundred louis. Honours were now heaped upon him; he was admitted free associate to the Academies of Sciences and of Inscriptions, and appointed first physician to the duke of Orleans, in the room of Tronchin. His reputation increased in proportion as his merits were displayed on a wider theatre. He practised as a physician at Paris for nearly ten years, and received the most flattering testimonials of public approbation.

The outbreak of the French Revolution compelled Barthes to leave Paris. He lost considerable part of his fortune, and retired to Carcassonne, where he devoted himself to the study of theoretical medicine. It was in this retreat that he gave to the world his *Nouvelle Mécanique des Mouvements de l'Homme et des Animaux*, which appeared in 1798.

On the re-establishment of the College of Medicine at Montpellier, Barthes was naturally looked upon as the person most likely to revive its former fame. But age and infirmity operated to dissuade him from re-uming the laborious office of teacher, and he was accordingly nominated honorary professor. In 1802 he received several marks of favour from the new government under Bonaparte; he was nominated titular physician to the Government, and afterwards consulting physician to the emperor, and member of the Legion of Honour.

His *Traitement des Maladies Goutteuses*, in two vols. 8vo, appeared in 1802, and he afterwards occupied, himself in preparing for the press a new edition of his *Éléments de la Science de l'Homme*, of which he just lived to see the publication. His health had been declining for some years before his death, which took place soon after his removal to Paris, on the 15th of October 1806, in the 72d year of his age. He bequeathed his books and manuscripts to M. Lordat, who, in consequence, published two volumes of *Consultations de Médecine*, Paris, 1810, 8vo, to which he prefixed a preface of his own. Another posthumous work of Barthes, the *Traité du Boze*, preceded by some account of his life, was edited in 1807 by his brother, M. Barthes de Marmorétres.

Barthes has enjoyed a much higher reputation on the Continent than in England, where, indeed, his writings

are comparatively little known. His principal work is the *Nouveaux Mémoires de la Science de l'Homme*, in which he unfolds his doctrine of the vital principle, or formative force. He was one of the strongest opponents of the theory which would explain the phenomena of life by physical or chemical laws. (See Lardat, *Exposition de la doctrine médicale de P. J. Barthes*, 1818.)

**BARTHOLINUS, GASPARD**, a learned Swede, born in 1585, at Malmö. His precocity was extraordinary; at three years of age he was able to read, and in his thirteenth year he composed Greek and Latin orations, and delivered them in public. When he was about eighteen he went to the University of Copenhagen, and he afterwards studied at Rostock and Wittemberg. He then travelled through Germany, the Netherlands, England, France, and Italy, and was received with marked respect at the different universities he visited. In 1613 he was chosen professor of medicine in the University of Copenhagen, and filled that office for eleven years, when, falling into a dangerous illness, he made a vow, that if it should please God to restore him, he would apply himself solely to the study of divinity. He recovered, observed his vow, and soon after obtained the professorship of divinity, with the canonry of Botschild. He died on the 13th of July 1630, after having written nearly fifty works on different subjects.

**BARTHOLINUS, THOMAS**, a physician, son of the above, was born at Copenhagen in 1619. He studied medicine at Leyden for three years (1637-40). He then travelled into France, and resided two years at Paris and Montpellier, in order to improve himself under the distinguished physicians of those universities; after which he visited Italy, remained three years at Padua, and then went to Basel, where he obtained the degree of doctor in philosophy. Returning to Copenhagen, he was appointed professor of mathematics in 1647, and next year was nominated to the chair of anatomy, for which he was better qualified. This he held for thirteen years, distinguishing himself by several observations respecting the lacteal and lymphatic vessels, shortly after their discovery by Olaus Rudbeck. His close application, however, having affected his health, he resigned his chair in 1661, and retired to a little estate at Hagestaad, near Copenhagen, where he hoped to spend the remainder of his days in peace; but his house having been burnt in 1670, his library, with all his books and manuscripts, was consumed. In consideration of this loss the king appointed Bartholinus his physician, with a handsome salary, and exempted his land from all taxes; the University of Copenhagen also chose him for their librarian; and, in 1675, he was honoured with a seat in the grand council of Denmark. He died on the 4th of December 1680. He wrote *Anatomia Gaspardi Bartholini Parentis, novæ Observationibus primum locupletata*, 8vo; *De Menstris in Natura et Medicina*, 4to; *Schedion de Armillis Veterum, præsertim Danorum*, 8vo; and several other works.

**BARTHOLOMEW, ST** († 708), son of Talmaj, one of the twelve apostles, generally supposed to have been the same as Nathanael (John i. 45). He was a native of Cana in Galilee (John xxi. 2), and was introduced by Philip to Jesus, who, on seeing him approach, at once pronounced that eulogy on his character which has made the name Nathanael almost synonymous with sincerity. He was a witness of the resurrection and the ascension, and returned with the other apostles to Jerusalem. Of his subsequent history we have little more than vague traditions. According to Eusebius (*Hist. Eccles.*, v. 10), when Pantænus went on a mission to the Indians (towards the close of the 2d century), he found among them the Gospel of Matthew, written in Hebrew, which had been left there by the apostle Bartholomew. Jerome (*De Vir. Illust.*, c. 36) gives a

similar account. But the name Indians is applied by ancient writers to so many different nations, that it is difficult to determine the scene of Bartholomew's labours. Moasheim (with whom Neander agrees) is of opinion that it was a part of Arabia Felix, inhabited by Jews, to whom alone a Hebrew gospel could be of any service. According to the received tradition, this apostle was flayed alive and crucified with his head downwards, at Albanopolis in Armenia, or, according to Nicephorus, at Urbanopolis in Cilicia. A spurious gospel which bears his name is in the catalogue of apocryphal books condemned by Pope Gelasius. The festival of St Bartholomew is celebrated on the 24th of August.

**BARTOLINI, LORENZO**, an Italian sculptor, was born in 1777, of very humble parents, at Vernio in Tuscany. After various vicissitudes in his youth, during which he had acquired great skill and reputation as a modeller in alabaster, he came to Paris in 1797. He there studied painting under Desmarests, and afterwards sculpture under Lemot. The bas-relief Cleobis and Biton, with which he gained the second prize of the Academy in 1803, at once established his fame as a sculptor of first-rate ability, and gained for him a number of influential patrons. He executed many minor pieces for Danton, besides busts of Méhul and Cherubini. His great patron, however, was Napoleon, for whom he executed a colossal bust, and who sent him to Carrara to found a school of sculpture. He remained in Carrara till after the fall of Napoleon, and then took up his residence in Florence, where he continued to reside till his death in 1850. His works, which include an immense number of busts, are numerous and varied. The best are, perhaps, the group of Charity, the Hercules and Lichas, and the Faith in God, which exemplify the highest types of Bartolini's style. By the Italians he is ranked next to Thorwaldsen and Canova.

**BARTOLOZZI, FRANCESCO**, a distinguished engraver, was born at Florence in 1735, or, according to some authorities, in 1730. He was originally destined to follow out the profession of his father, who was a silversmith; but he manifested so much skill and taste in designing that he was placed under the superintendance of two Florentine artists, who instructed him in painting. After devoting three years to that art, he went to Venice and studied engraving under the famous Joseph Wagner. He made very rapid progress, and executed some works of considerable importance at Venice. He then removed for a short time to Rome, where he completed a set of engravings representing events from the life of St Nilus, and after returning to Venice, set out for London in 1764. For nearly forty years he resided in London, and produced an enormous number of engravings, the best being those of Clytie, after Annibale Carracci, and of the Virgin and Child, after Carlo Dolce. A great proportion of them are from the works of Cipriani and Angelica Kauffmann. Bartolozzi also contributed a number of plates to *Boydell's Shakespeare Gallery*. In 1802 he was invited to Lisbon to superintend a school of engraving in that city. He remained in Portugal till his death, at an advanced age, about the year 1816.

**BARTOLUS**, professor of the civil law at the University of Perugia, and the most famous master of the dialectical school of jurists, was born in 1314, at Sasso Ferrato, in the duchy of Urbino, and hence is generally styled Bartolus de Saxo Ferrato. His father was Francisus Severi, and his mother was of the family of the Alfani. He studied the civil law first of all under Cino at Perugia, and afterwards under Oldradus and Jacobus de Belvisio at Bologna, where he was promoted to the degree of doctor of civil law in 1334. His great reputation dates from his appointment to a chair of civil

law in the University of Perugia, 1343, where he lectured for many years, raising the character of the law school of Perugia to a level with that of Bologna. He died in 1357 at Perugia, where a magnificent monument recorded the interment of his remains in the church of San Francisco, by the simple inscription of "Ossa Bartoli." Bartolus has left behind him a great reputation, and many writers have sought to explain the fact by attributing to him the introduction of the dialectical method of teaching law; but the dialectical method had been employed by Odofredus, a pupil of Accursius, in the previous century, and the successors of Odofredus had abused it to an extent which has rendered their writings in many instances unprofitable to read, from the subject matter being overlaid with dialectical forms. It was the merit of Bartolus, on the other hand, that he employed the dialectical method with advantage as a teacher, and discountenanced the abuse of it; but his great reputation is more probably owing to the circumstance that he revived the exegetical system of teaching law (which had been neglected since the ascendancy of Accursius), in a spirit which gave it new life, whilst he was enabled to impart to his teaching a practical interest, from the judicial experience which he had acquired whilst acting as assessor to the courts at Todi and at Pisa before he undertook the duties of a professorial chair. His treatises *On Procedure* and *On Evidence* are amongst his most valuable works, whilst his *Commentary on the Code of Justinian* has been in some countries regarded as of equal authority with the code itself.

BARTON, BENJAMIN SMITH, M.D., an American naturalist, who was the first professor of botany and natural history in a college in the United States. He was born in Pennsylvania in 1766, studied for two years at Edinburgh, and afterwards graduated at Göttingen. He settled at Philadelphia, and soon obtained a considerable practice. In 1789 he was appointed to the professorship above mentioned in Philadelphia College; he was made professor of materia medica in 1795, and on the death of Dr Rush in 1815 he obtained the chair of practical medicine. In 1802 he was chosen president of the American Philosophical Society. Barton was the author of various works on natural history, botany, and materia medica. By his lectures and writings he may be said to have founded the American school of natural history. He died in 1815.

BARTON, ELIZABETH, the "Maid of Kent," belonged to the village of Aldington in Kent. She was a pious, nervous, and enthusiastic person, subject to epilepsy; and her enthusiasm, unfortunately for herself, took a political turn at a somewhat critical period in English history. When all England was excited with the attempts made by Henry VIII. to obtain a divorce from Queen Catherine, Elizabeth Barton saw visions and heard speeches, all of which related to the contemplated divorce. These she confided to her parish priest, Richard Masters, and he made them known to Dr Bookling, a canon of Canterbury. Through these men they became widely known, and were everywhere proclaimed to be divine revelations. The chapel at Aldington became the centre of many pilgrimages, and the scene of many excited and tumultuous assemblies. Elizabeth Barton was commonly believed to be a prophetess, and was called the "holy maid of Kent." Meanwhile her visions continued; she saw letters written in characters of gold sent to her by Mary Magdalen, which contained both revelations and exhortations. Among other things she declared that it was revealed to her that if the contemplated divorce took place, the king would be a dead man within seven months. The principal agents for the Pope and for Queen Catherine lent themselves to fan the excitement. Even such men as bishops Fisher and Warham and Sir Thomas More corresponded with the Maid of Kent.

At last the king's wrath was aroused. In 1533 Elizabeth with her principal supporters, Masters, Bookling, and several others, were examined before parliament, and sentenced to be executed. She was beheaded at Tyburn, April 21, 1534. (*Of Burnet's History of the Reformation in England; Lingard's History of England.*)

BARUCH, son of Neriah, was the friend and amanuensis of the prophet Jeremiah. After the temple at Jerusalem had been plundered by Nebuchadnezzar, he wrote down Jeremiah's prophecies respecting the return of the Babylonians to destroy the state, and read them in the temple before the assembled people at the risk of his life. The roll having been burned by the king's command, Jeremiah dictated the same again. When the temple was destroyed, Baruch went to Egypt with Jeremiah, having been blamed as the prompter of the threatening prophecies uttered by the latter. Nothing certain is known as to his death,—some accounts representing him as dying in Egypt, others in Babylonia. The Talmud adopts the latter opinion, making him the instructor of Ezra, to whom he is said to have communicated the traditions he had received from Jeremiah.

The BOOK OF BARUCH belongs to the Apocrypha, according to Protestants, and to the deuterocanonical productions, according to Roman Catholics.

There is hardly sufficient cause for dividing the book, as some critics suggest, between two writers. The author of iii. 9-v. 9 uses Isaiah as well as Jeremiah in two places. A new paragraph undoubtedly begins at iii. 9, which has little connection with the preceding context, and differs from it perceptibly both in matter and form; yet it has the same general object. From reproof the language passes to hope and Messianic happiness, and it becomes livelier and more elevated. It is purer Greek without doubt. The supposed traces of Alexandrian culture are somewhat indistinct. Wisdom is not spoken of in the Alexandrian manner (iii. 24), but rather in the same way as in Sirach, which is Palestinian.

Much difference of opinion prevails regarding the original language. Some are for a Greek original, others for a Hebrew one; while Fritzsche and Ruetschi think that the first part was composed in Hebrew, the second in Greek. The original seems to have been Hebrew, though Jerome says that the Jews had not the book in that language; and Epiphanius asserts the same thing. The testimony of the former resolves itself into the fact that the original had been supplanted by the Greek; and that of the latter is not of much value, since he gives Baruch, along with Jeremiah and the Lamentations, in a second list of the canonical books.<sup>1</sup> We rely on the statement that the work was meant to be publicly read in the temple (i. 14) as favourable to a Hebrew original, as well as on the number and nature of the Hebraisms, which are sometimes so peculiar that they cannot be resolved into the authorship of a Greek-speaking Jew. That the writer was a Palestinian appears from various passages, such as ii. 17, "For the dead that are in the graves, whose souls are taken from their bodies, will give unto the Lord neither praise nor righteousness;" "Hearken, O ye that dwell about Zion" (iv. 9); "Ye have forgotten the everlasting God that brought you up; and ye have grieved Jerusalem that nursed you" (iv. 8). Both the latter passages betray a Palestinian. Besides, the conception of Wisdom in iii. 12, &c., is Palestinian rather than Alexandrian; for the words in iii. 37 do not refer to the incarnation of the Logos, but to personified Wisdom, as in Sirach xxiv. 10. This points to a Hebrew original. The version seems to be free, especially in the latter part.

<sup>1</sup> *Hebræi*, viii. 6; compare *De Mem. et Pœd.*, c. 23; *ibid.*, c. 5.



Who was the translator? A comparison of the Septuagint translation of Jeremiah with that of Baruch will suggest the answer. The agreement between the two is remarkable. Constructions, phrases, and words are the same in them, so that we may conjecture with Ewald and Hitzig that the same translator appears. The words βαβυλων, δεσπολη, χαρμωδον, γαυραμα, δεσμετης, δεσποτισμος, ενομα μου επικαλιθους ἐπὶ τῶν are common to both. The LXX. version of Jeremiah was not made till the 1st century A.C. or later; and Theodotion's translation or recension of it in the second. It is some confirmation of the opinion that Greek was not the original when marginal notes are found in the Hexaplar-Syriac version printed by Ceriani, in which the Hebrew is repeatedly referred to. Nothing seems to disprove the assumption that Theodotion, from whose version that of Paul of Tels was taken, had the Hebrew original before him.

Though Baruch professes to have written the book, a later writer speaks in his name. Jeremiah's faithful friend is said to have composed it at Babylon. This view is untenable on the following grounds:—

1. The work contains historical inaccuracies. Jeremiah was living in the fifth year after the destruction of Jerusalem, yet the epistle is dated that year at Babylon. It is unlikely that Baruch left Jeremiah, since the two friends were so united. According to Baruch i. 3, Jeconiah was present in the great assembly before which the epistle was read, whereas we learn from 2 Kings xxv. 27 that he was kept a prisoner as long as Nebuchadnezzar lived. Joakim is supposed to be high priest at Jerusalem (i. 7). But we learn from 1 Chron. vi. 15 that Jehozadak filled that office the fifth year after Jerusalem was destroyed. In i. 2 there is an error. The city was not burned when Jehoiachim was carried away. And if the allusion be to the destruction of the city by Nebuchadnezzar, the temple and its worship are supposed still to exist in i. 8-10. The particulars narrated are put into the fifth year of the exile; yet we read, "Thou art waxen old in a strange country" (iii. 10).

2. Supposing Baruch himself to have been the writer, books later than his time are used in the work. Nehemiah is followed, as in ii. 11 (comp. Nehem. ix. 10). But Eichhorn's language is too strong in calling the contents "a rhapsody composed of various writings belonging to Hebrew antiquity, especially Daniel and Nehemiah."<sup>1</sup>

The date of the work is given indefinitely in i. 2, "In the fifth year, and in the seventh day of the month, what time as the Chaldeans took Jerusalem, and burnt it with fire." The natural meaning of these words is, "The fifth year after the destruction of Jerusalem by Nebuchadnezzar," not "the fifth year of Jehoiachim's captivity." The day is given, not the month; and therefore De Wette conjectures that ἐν should be μηνί; but MS. authority is against him. It is probable that the name of the month has dropped out, i.e., Σίβας. The Palestinian abode of the writer is pretty clear, especially from the melancholy view of death presented in ii. 17, iii. 19, resembling that in Psalms vi. 6, lxxviii. 18, ciii. 29. In Alexandria the Jews had attained to a clear idea of immortality, in Palestine not. The translation was made in Egypt, which accounts for various expressions savouring of Alexandrianism, as in iii. 23, 24, 26. There are evident points of contact between Daniel and Baruch, as appears from Baruch i. 15-18, which agrees almost verbally with Daniel ix. 7-10. So ii. 1, 2 coincide with Daniel ix. 12, 13; and ii. 7-17 with Daniel ix. 13-18. Hitzig thinks the two authors were identical, but this can hardly be allowed; for the tone and atmosphere of Baruch bear no perceptible trace of the

Syrian persecutions or Maccabean struggle. Daniel borrowed from Baruch pretty closely in some passages. We suppose that the translator was separated from the author by a considerable period, probably 200 years. Perhaps the author lived about 300-290 A.C.

According to Jerome and Epiphanius, the Jews did not receive the book into their canon; nor is it in the lists given by Josephus, Melito, and others. It has been thought, however, that Origen considered it canonical, because in his catalogue of sacred books he gives Lamentations and "the epistle" along with Jeremiah; and Jeremiah's epistle formed a part of Baruch. The testimony of Origen on this point is perplexing; but it is conceivable that some Jews may have thought very highly of the book in his time, though its authority was not generally admitted among their co-religionists.<sup>2</sup> From the position which the book occupied in the Septuagint, i.e., either before or after Lamentations, it was often considered an appendix to Jeremiah by the early Christians, and was regarded in the same light, and of equal authority. Hence the words of it were often quoted as Jeremiah's by Irenaeus, Clemens Alexandrinus, and Tertullian. Cyril of Jerusalem reckons it with the canonical books, among the αἱ θεοτεκτονοὶ or θελαὶ γραφαί; and the epistets so applied cannot be explained away by Protestants.

The versions are the two Latin, a Syriac, and an Arabic. The Latin one in the Vulgate belongs to a time prior to Jerome, and is tolerably literal. Another, somewhat later, was first published by Joa. Maria Caro in 1688, and was reprinted by Sabatier, side by side with the ante-Hieronymian one, in his *Bibliotheca Sacrorum Latinae Versiones Antiquae*.<sup>3</sup> It is founded upon the preceding one, and is less literal. The Syriac and Arabic versions, printed in the London Polyglott, are literal. The Hexaplar-Syriac version, made by Paul, bishop of Tels, in the beginning of the 7th century, has been published by Ceriani.<sup>4</sup> The most convenient editions of the Greek text are Tischendorf's, in the second volume of his Septuagint, and Fritzsche's in *Libri Apocryphi Veteris Testamenti Graeci*, 1871. (See Davidson's *Introduction to the Old Testament*, vol. iii.; *Kurzgefasstes exegetisches Handbuch zu den Apokryphen des alten Testaments, erste Lieferung*; Ewald's *Geschichte des Volkes Israel*, vol. iv.; De Wette's *Einleitung*, §§ 321-323; Wette's *Einleitung in die heiligen Schriften des A. T., zweyter Theil, dritte Abtheilung*.)

*Epistle of Jeremy*.—An epistle of Jeremiah's is often appended to Baruch, forming the sixth chapter. According to the inscription, it was sent by the prophet by God's command to the Jews who were to be carried captive to Babylon. The writer describes the folly and absurdity of idolatry in a declamatory style, with repetitions somewhat like refrains. Thus, in verses 16, 23, 29, 65 occurs the sentence; "Whereby they are known not to be gods; therefore fear them not;" "How should a man then think and say that they are gods," in 40, 44, 56, 64, 69; "How then cannot men perceive that they be no gods," in 49, 52. These and other repetitions are unlike Jeremiah's. The concluding verse is abrupt.

All the relation this epistle has to Jeremiah is, that the contents and form are derived from Jeremiah x. 1-16 and xxix. 4-23. Its combination with Baruch is purely accidental. It could not have been written by Jeremiah, though many Catholic theologians maintain that it was. The Hellenist betrays himself in a few instances, as when he speaks of kings, verses 51, 53, 56, 59. Though Wette tries to prove that the epistle was written in Hebrew, which is

<sup>1</sup> See Wette's note on this point in *Herbst's Einleitung, erster Theil* pp. 14, 15.

<sup>2</sup> See vol. ii. p. 784, &c.

<sup>3</sup> *Monumenta Sacra et Profana*, tom. i. fasc. 1.

<sup>4</sup> *Einleitung in die apokryphischen Schriften des A. T.*, p. 382.

consistent with Jeremiah's authorship, his arguments are invalid. The original is pure Hellenistic Greek. The warning against idolatry bespeaks a foreigner living out of Palestine. The place of its origin was probably Egypt; and the writer may have lived in the Maccabean period, as we infer from his making the exile last for seven generations, i.e., about 210 years. Jeremiah, on the contrary, gives the time as 70 years in round numbers. The oldest allusion to the epistle is commonly found in 2 Maccab. ii. 2, where a few words are similar to the fourth verse of our epistle. But the appropriateness of the supposed reference is doubtful.

The old Latin version of the epistle, published by Sebastian, which is in the Vulgate, is literal. The Syriac is freer. The Arabic is more literal than the Latin. Both are in the London Polyglott. The Hexaplar-Syriac was published by Ceriani. (a. d.)

**BARYTES**, or **BARYTA**, an oxide ( $BaO$ ) of the metal barium, usually prepared from the two most common ores of the substance, the sulphate and the carbonate of baryta. It is a highly caustic alkaline poisonous body, which with water forms a hydrate of baryta. On a commercial scale baryta is prepared from the native carbonate (Witherite) by exposing the mineral, mixed with one-tenth of its weight of lamp black, to a very high heat. It is now largely employed in the beet sugar manufacture for separating crystallized sugar from the molasses. A solution of the hydrated oxide, under the name of baryta-water, is of very great use in the chemical laboratory for precipitating metallic oxides, and on account of its sensitiveness to carbonic acid. Sulphate of baryta, or heavy spar, the cawk of miners, is a mineral of very high specific gravity (4.59), found abundantly in veins in the mountain limestone of England and frequently associated with metallic ore. When reduced to powder the white varieties are sometimes used as a pigment, but the powder is more frequently applied as an adulterant to white lead. Heavy spar is also used in the manufacture of pottery. The powdered carbonate of baryta is used to some extent in the manufacture of glass, taking the place of a part of the alkali in plate glass, and of some portion of red-lead in flint glass. Cassel green, or Rosenstiehl's green, is a pigment manufactured from the calcined manganate of baryta. Both the nitrate and the chloride are of great value as chemical reagents. The nitrate and chlorate are also used to produce a green light in pyrotechny.

**BASE BALL**, a game which holds the same position in the United States of America as cricket does in Great Britain. It was founded on the old British game of rounders, though many additions and alterations have been made. Americans do not appreciate the patience of Englishmen, and do not care to witness a cricket match which may extend to three days, and then remain undecided, whereas the average time of a base ball match is from two hours to two hours and a half. The first regular base ball society was the old Knickerbocker Club, founded at New York in the autumn of 1845; and for fifteen years the sphere of play was very limited. In the spring of 1860 the Excelsior Club was inaugurated at Brooklyn, New York, and the amateur element, in contradistinction to the professional, gave a marked impetus to the pastime. This club was second to none in the United States of America, either in social standing or as correct exponents of the game. The secession of the Confederate States soon after, and the sanguinary civil war which followed, was a serious interruption to national or other sports, and base ball became almost obsolete till the season of 1865. Then it began to spread throughout the Union, and to be recognized as a profession, not a few devoting their whole time to it and being paid for their services. Now there are hundreds of games played for every one ten years since. In the

summer of 1874 the Boston Base-Ball Club and the Athletic Base Ball Club of Philadelphia crossed the Atlantic and played a series of exhibition matches in England and Ireland; but, as anticipated, the pastime did not find favour with Englishmen or take root in British soil.

The scene chosen for the pastime should be a clear level piece of turf, not less than 500 feet by 350 feet. The following diagram shows the laying out of the ground.

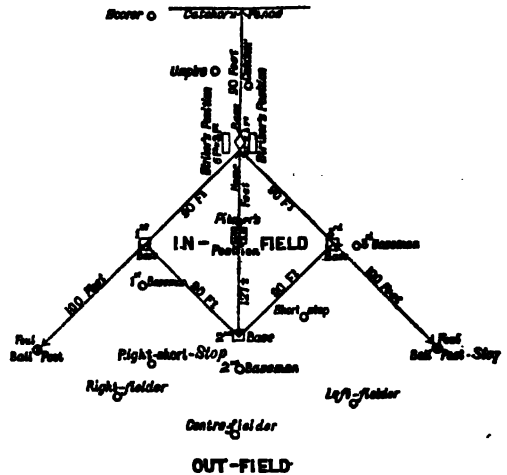

Diagram illustrating the Game of Base Ball.

The position of the bases and base lines may be likened to a 90 feet square shaped diamond. The first point to be selected is the rear angle of the home base, which should be not less than 90 feet from the most suitable end of the ground, and equi-distant from each side. Lay out this base 1 foot square, and from the front apex measure 127 feet 4 inches in a straight line down the ground, and the point reached will be the centre of the second base. Take a cord, 180 feet long, fixing one end on the front angle of the home base, and the other on the centre of the second base. By hauling the centre of this cord taut on the two sides, two isosceles right angled triangles will be formed, and the 90 feet square completed. Standing on the home base and looking down the ground, the apex of the triangle on the right hand is the centre of the first base, and of that on the left hand the centre of the third base. 48 feet from the front angle of the home base has then to be measured down the diagonal of the square, in order to fix the centre of the pitcher's position, which is 6 feet square. Lastly come the foul ball posts, which are on a line with the home and first bases, and home and third bases, and not less than 100 feet from the centres of first and third bases respectively.

Formerly, nine a side was the usual number of players; but, latterly, an additional man has been introduced as right short-stop, and the sides increased to ten. Their positions are marked in the above diagram. The theory of the game is that one side takes the field, and the other goes in. The pitcher then delivers the ball to the striker, who endeavours to hit it in such a direction as to elude the fielders, and enable him to run round all the base lines home without being put out. If he succeeds a run is scored. When three players are put out the fielding side come in; and after nine innings have been played the side which have scored the most runs wins the game. The rules are voluminous and minute, but the pith of them may be gleaned from the following resumé:—

The ball must weigh not less than 5 ounces or more than 5½ ounces avoirdupois, must be not less than 9 inches or more than 9½ inches in circumference, and must be composed of 1 ounce avoirdupois of vulcanized india-rubber, covered with worsted and leather, red being the most suitable colour for the latter. The bat must be circular in shape, not exceeding 2½ inches in diameter at any part, or 42 inches in length, and must be made exclusively of wood. The bases shall be 1 foot square, the first, second, and third consisting of white canvas

legs securely fastened to the ground, and the home base of white stone or marble, level with the ground, and with one angle facing the pitcher. Unless five innings on each side are concluded it is no game. No game can be drawn, unless play is stopped by darkness or the weather, when the score of the two sides is even. The pitcher's position shall be within a 6 feet square, the front of which shall be 15 feet from the centre of the home base, and the centre equidistant from the centre of first and third bases, each angle being marked by a flat iron or stone plate 6 inches square. In delivering the ball, the pitcher must not move either foot outside the limits of the square, and the hand must not be raised higher than the hip. All balls delivered over the home base, and at the height requested by the striker, are fair balls. All other balls are unfair or called balls, and if three occur in succession the striker is allowed to take the first base, and any other players move on a base accordingly. A striker may, however, take an unfair ball at his own risk. Balking, or pretending to deliver the ball and not doing so, is inadmissible, and any player, on first, second, or third base, is allowed to run a base whenever balking is attempted. If, after being warned by the umpire, three balks are made during the same innings, the out side is once forfeit to the game. A ball which hits the bat without being struck at, or the person of the striker or umpire, is a dead ball and out of play. The striker shall stand in a space of ground 6 feet by 3 feet, on either side of the home base, extending 2 feet in front and 4 feet behind the centre thereof, and the inside 1 foot from the outside angle thereof, otherwise it is a foul strike. The striker may call for a high ball, which shall be delivered above his waist, but below his shoulder, or a low ball, i.e., below his waist, but not within 1 foot of the ground. Should the striker fail to strike three fairly delivered balls, he must run the first base. The foul ball lines are unlimited in length, and shall extend in a straight line from the front angle of the first base through the centres of first and third bases respectively. A ball is fairly hit if it first touches the ground, a player's person, or other object, on or in front of the foul ball lines. A batsman is out—(1.) If a fair ball be caught before touching the ground, no matter how held by the fielder catching it, or whether the ball first touches the person of another fielder or not, provided it be not caught by the cap; (2.) If a foul ball be similarly held, or if it be so held after touching the ground but once; (3.) If a fair ball be securely held by a fielder while touching the first base with any part of his person before the base-runner touches said base, after hitting a fair ball; (4.) If the batsman, after striking three times at the ball and failing to hit it, and, running to first base, fails to touch that base before the ball is legally held there; (5.) If, after the batsman has similarly failed to hit the ball, it be caught either before touching the ground, or after touching the ground but once; (6.) If the batsman wilfully strikes at the ball to hinder the ball from being caught; (7.) If the batsman hit the ball on a called foul strike, and it be caught either fair or foul, or if he make two called foul strikes. Directly a striker has fairly struck a fair ball he becomes a base-runner; starting from the home base to first base, thence to second, third, and home bases respectively, all bases being invariably run in this order. No base-runner is compelled to vacate his base except by the striker's striking a fair ball. The lines from base to base are 3 feet wide, clearly marked out on the turf, and a base-runner who leaves the base line to avoid being touched by the ball in the hands of a fielder is out. A run is scored when any base-runner reaches the home base again, after touching all the other bases in proper succession, and provided three players are not put out. No base can be run, or run scored, when a fair strike is caught before touching the ground, unless the base-runner returns to the base he started from, which he cannot leave again until the ball is held by the pitcher, wherever that fielder may happen to be. No unavoidable obstruction may be offered to any base-runner keeping the base lines. A base-runner is out—(1.) If, while the ball is in play, he be touched by a fielder with the ball in hand, when no part of his person is touching a base; and should the said fielder, while in the act of touching the base-runner, have the ball knocked out of his hand, the base-runner so touched shall be declared out; (2.) If the ball be held by a fielder on the first base before the base-runner, after hitting a fair ball, touches that base; but if a fielder holding the ball, and a base-runner touch a base simultaneously, the latter shall not be declared out; (3.) If he fail to touch the base he runs for, the ball being held by a fielder, while touching said base, before the base-runner returns and touches it; (4.) If he in any way interfere with or obstruct a fielder while attempting to catch a fair fly-ball or a foul ball; (5.) If he wilfully obstruct a fielder from fielding a ball. (6.) If he intentionally kick the ball or let it strike him. The umpire must be thoroughly conversant with the game and all minutiae of the rules. He is the sole arbiter of every point of play, whether pitching, catching, fielding, striking, or running the bases.

The catcher's duty is to catch all balls pitched to the striker. He stands close to the striker's position when the pitching is slow, and some 50 feet off when it is swift. He

must be a sure catch in order to catch the striker out when opportunity occurs, and a swift and accurate thrower of the ball to the basemen. The pitcher is the most responsible person on the out side. His great object is to deceive the striker as to where a ball is coming, and he must therefore have full command over the ball, besides possessing the nerve to face any catches hit straight at him. The first, second, and third basemen must all be sure catchers, swift and accurate throwers, and good judges of which bases to send the ball to in order to put an opponent out. The short-stop must be an active man, of great coolness and judgment, a general backer-up of the in-field. He is placed near the line from second to third base. The right, centre, and left fielders must all be sure catchers, good long distance throwers, and active runners. Right short-stop is generally the captain of the side, and is available either in this position or anywhere else where an extra hand is required. Having less work to do than any other fielder, he has better opportunities of attending to his general duties of supervision. The usual positions of all the fielders are defined in the diagram. The catcher, pitcher, first and third basemen, and short-stop comprise the in-field; the remainder the out-field.

The pastime requires good catching, throwing, and running powers, combined with courage, nerve, good judgment, and quick perception of what to do in the field. The great drawback is so much being left to the umpire, and his decision being so frequently called for. Hardly a ball is pitched or struck, or a base run without his being called on for a decision under some rule or other, whereas the details of the game should be so plain and clear as only to call for an umpire's decision under exceptional circumstances. The attitude of the striker is not an elegant one, and the pitcher is allowed to keep the former's muscles too long on the stretch before actually delivering the ball. Base ball is a quicker and more lively pastime than the great English national game of cricket, which is the chief thing to be said in its favour. (H. T. W.)

**BASEDOW, JOHANN BERNHARD**, a German author, born at Hamburg 11th September 1723, was the son of a hairdresser. He was educated at the Johanneum in that town, where he came under the influence of the well-known rationalist, H. S. Reimarus, author of the *Wolfenbüttel Fragments*. In 1744 he went to Leipzig to study theology, and gave himself up entirely to the instructions of Professor Crusius, and to the study of philosophy. This at first induced sceptical notions; a more profound examination of the sacred writings, and of all that relates to them, brought him back to the Christian faith, but, in his retirement, he formed his belief after his own ideas, and it was far from orthodox. He returned to Hamburg, where in 1749, M. de Quaslen, privy-councillor of Holstein, appointed him preceptor to his son. Basedow now began to exhibit his really remarkable powers as an educator of the young, and acquired so much distinction that, in 1753, he was chosen professor of moral philosophy and belles-lettres in the academy of Sorø in Denmark. On account of his theological opinions he was removed from this post and transferred to Altona, where some of his published works brought him into great disfavour. He left off giving lessons without losing his salary; and, towards the end of 1767, he abandoned theology to devote himself with the same ardour to education, of which he conceived the project of a general reform in Germany. He began by publishing *An Address to the Friends of Humanity, and to Persons in Power, on Schools, on Education, and its Influence on Public Happiness, with the Plan of an Elementary Treatise on Human Knowledge*, Hamburg, 1768. He proposed the reform of schools and of the common methods of instruction, and the establishment of an institute for

qualifying teachers,—soliciting subscriptions for the printing of his elementary work, where his principles were to be explained at length, and illustrated by plates. The subscriptions for this object amounted to 15,000 thalers (£2250), and in 1774 he published his *Elementary Work*, a complete system of primary education, intended to develop the intelligence of the pupils and to bring them, so far as possible, into contact with realities, not with mere words. The work was received with great favour, and Basedow obtained means to establish an institute for education at Dessau, and to apply his principles in training disciples, who might spread them over all Germany. Little calculated by nature or habit to succeed in an employment which requires the greatest regularity, patience, and attention, he, however, engaged in this new project with all his accustomed ardour. The name of *Philanthropin* appeared to him the most expressive of his views; and he published at Leipzig in 1774 a pamphlet entitled *The Philanthropinon founded at Dessau*, containing the details of his plan. He immediately set about carrying it into execution; but he had few scholars, and the success by no means answered his hopes. Nevertheless, so well had his ideas been received that similar institutions sprang up all over the land, and the most prominent writers and thinkers openly advocated the plan. Had Basedow been a man of ordinary tact, his success would have been complete. But his temper was intractable, and his management was one long quarrel with his colleagues. The institution was finally shut up in 1793. Basedow died at Magdeburg on the 25th July 1790. Notices of his life and works have been published by Rathmann (1791) and Meyer (1791-2).

**BASEL, BÂLE, or BASLE** (the first being the German, the others the French and Old French forms of the name), a canton in the N.W. of Switzerland, with an area of 184 English square miles. It is bounded on the N.W. by Alsace, N. by the grand-duchy of Baden, E. by the canton of Aargau, and S. and S.W. by those of Solothurn and Berne. The canton is traversed by the Jura chain, the highest peaks of which rise to from 4000 to 5000 feet. With the exception of the Rhine and its tributaries,—the Birse and the Ergolz,—there are no streams of any magnitude. The soil is for the most part fertile and well cultivated, the mountain sides affording excellent pasturage. The principal pursuits of the people are agricultural and pastoral, though here and there, as at Liestal, Sissach, and Münchenstein, coal-mining is carried on. The chief manufactures are ribbons, woollen, linen, and cotton goods, and iron and steel wares. Politically the canton consists of two divisions, one urban and the other rural (Basel-stadt and Basel-landschaft), each with its own constitution and laws. The former sends two members to the National Council; its legislative power is in the hands of a Great Council which consists of 134 members, chosen for six years, and its executive power belongs to a Lesser Council of 15 members. In the rural division the legislative body (or *Landrat*) is chosen for three years, and has the ultimate authority over all departments; the executive council consists of five members elected for the same period; it sends three members to the National Council. The prevailing language is German. Population of Basel-stadt in 1870, 47,760, and of Basel-landschaft, 54,721.

**BASEL, or BÂLE**, the capital of the above canton, and, next to Geneva, the largest city in Switzerland, is situated on both sides of the Rhine, 43 miles N. of Berne, in lat. 47° 33' N., and long. 7° 35' E. Great Basel, or the city proper, lies on the south side of the river, and is connected with Little Basel on the north side by a handsome bridge 800 feet long, which was originally erected in 1229. The city is generally well-built, but there are fewer

remarkable edifices than in many other Continental cities of similar size. The fine old Gothic cathedral, founded 1010, still stands, and contains a number of interesting monuments, besides the tombs of Erasmus, Ecclampadius, and other eminent persons. A re-decoration was skillfully effected in 1852-1856. Among other ecclesiastical buildings of interest may be mentioned St Martin's, restored in 1851; St Alban's, formerly a monastery; the church of the Bare-footed Friars, which now serves as a store house; Elizabeth's Church, of modern erection; and St Clara's in Little Basel. The town-hall was built in 1508 and restored in 1826. A post-office, a new bank, and an hospital are of recent erection. Besides the university,



Plan of Basel.

- |                       |                      |
|-----------------------|----------------------|
| A. Peter's Platz      | E. Botanical Gardens |
| B. Market             | F. University        |
| C. Barfusser Platz    | G. Town-Hall         |
| D. Zoological Gardens | H. Armoury           |

which was founded by Pope Pius II. in 1459, and reorganized in 1817, Basel possesses a public library of 95,000 vols., with a valuable collection of MSS., a picture-gallery, a museum, a theological seminary for missionaries (established in 1816), a gymnasium, an industrial school, a botanical garden, an orphan-asylum, an institution for deaf-mutes, and various learned societies. Of these may be mentioned the Society for the Propagation of Useful Knowledge, founded in 1777 by Iselin, the Society of Natural History, the Society of National Antiquities, and the Bible Society, which dates from 1804 and was the first of the kind on the Continent. Basel is the seat of an active transit-trade between France, Germany, and Switzerland, and possesses important manufactures of silk, linen, and cotton, as well as dyeworks, bleachfields, and iron-works, the most valuable of all being the ribbon-trade. It has railway communication with both south and north. The Baden line has a station in Little Basel; and the central station for the Swiss and Alsace railways lies to the south-east of the city proper. Basel was the birthplace of Euler, Bernouilli, Iselin, and perhaps of Holbein; and the names of Erasmus, Ecclampadius, Gryneus, Merian, De Wette, Hagenbach, and Weckernagel, are associated with the university. Population in 1870, 44,834.

Basel (*Basilia*) first appears in the 4th century as a Roman military post. On the decay of the neighbouring city of *Augusta Rauracorum*, the site of which is still marked by the village of Augst, it began to rise into importance, and, after numerous vicissitudes, became a free city of the empire about the middle of the 10th century, and obtained a variety of privileges and rights. In 1566 the most of its buildings were destroyed by an earthquake.

In 1392 the town of Little Basel was acquired from the bishop by purchase. From 1431 to 1443 the meetings of a General Council were held in the city (see next article). After the battle of St Jacob in 1444, in the immediate neighbourhood, Basel was visited by the plague, and its population considerably diminished. In 1501 it became a member of the Swiss Confederacy; and it was one of the chief seats of the Reformation movement. The position of the city exposed it to many dangers during the Thirty Years' War and the subsequent disturbances of the neighbouring states; but in spite of all it continued to flourish. A peril of a more critical kind arose from within. The quasi-aristocratic Government of the city appropriated all political rights, and left the inhabitants of the rural districts unrepresented,—which gradually led to much discontent on the part of the latter, and ultimately to actual rebellion. It was not till 1833 that peace was firmly restored by the complete separation of the canton into the two divisions of *Basel-stadt* and *Basel-landchaft*, the former being allowed to include not only the city proper, but also the communes of Reihen, Bettingen, and Klein-Hänningen. The capital of the rural division is Liesthal, with (in 1870) a population of 3873.

**BASEL, THE COUNCIL OF (1431-1443)**, was the last of the three great reforming councils of the 15th century, coming after the councils of Pisa (1409) and Constance (1414-18). In these three councils the aim of the majority was to reform the church by destroying the absolute supremacy of the Pope, and by curbing the rule of the Roman curia; and the acts of these councils were all designed to re-establish the power of the episcopate by asserting the supremacy of oecumenical councils. At Pisa these aims were only indicated; at Constance they were so far successful that schismatic popes were deposed, and the council practically showed its superiority to the Pope by bestowing the papal chair on Martin V.; and although the fathers of Constance were compelled to separate before they could do much else in the way of reform, they practically laid the foundation by insisting that councils should be held frequently, and by ordering a new council to be called at the end of five years. The council summoned in obedience to this command was the Council of Basel, but the results of its meeting were simply to show the helplessness of the episcopate and the power of the Roman curia. At Basel the labours of Pisa and Constance were undone, and after this council thoughtful men began to see that the church could not be reformed without destroying the Papacy.

The Council of Basel was summoned by Martin V. (1431). He first appointed it to meet at Pavia, then at Siena, but Basel was at last fixed upon. At the very beginning Martin died, but his successor, Eugenius IV., sanctioned all his decrees; and the council accordingly met at Basel on the 23d of July 1431, under the presidency of Cardinal Julian Cesarini. At first all went well. The bishops took care to arrange the organisation of the council and its method of procedure as to make it a true and fair representative of the whole Catholic Church. The members of the council were divided into four equal classes, each consisting of about the same number of cardinals, archbishops, bishops, abbots, &c., and each completely organised, with its president, secretaries, and other officers. This was done to neutralise the votes and prevent the intrigues of the Italian bishops, who were very numerous, and for the most part under the power of the Roman curia. To each of the four was assigned the investigation of a special class of subjects. Each section met separately in its own hall thrice a week. Each section elected three of its number to form a committee of business. One-third of this committee was changed every month. All the

business had to pass through this committee, and it sent down special subjects to be discussed in each of the sections. When the section had discussed the matter it sent its decision with the reasons of it to each of the other sections, who then discussed the matter and gave their opinion upon it. If three sections were agreed upon it, the subject was brought before the whole council for general discussion and a final decision.

The three subjects which were specially assigned to this council were the reunion of the Greek and Latin Churches, the reconciliation of the Bohemians, and the reform of the church according to the resolutions come to at Constance. Soon after the beginning of the council the Roman curia took alarm at the zeal and determination of the assembled bishops, and by intrigues compelled the Pope, who was really anxious for reform, to do all he could to hinder the work of the fathers at Basel. Eugenius twice tried to dissolve the council; but it resisted, maintaining that a council being superior to the Pope could not be dissolved, and the Pope yielded. The bishops refused to admit the Pope's legates until they admitted the supremacy of the council and promised to obey its decrees.

The first business to which the members addressed themselves was to curb the power of the Pope and of the Roman curia. They tried to do this by attempting to stop the flow of money from all parts of Europe to Rome. They abolished the annates; they declared it illegal in a bishop to send the sum of money commonly presented on his investiture, &c.; and they passed many laws to restrain the luxury and vice of the clergy. These proceedings so alarmed Eugenius that he resolved either to bring the council within the reach of his influence or to dissolve it. The occasion for interference arose out of a debate which the subject of reunion with the Greek Church gave rise to. The Emperor John Paleologus, induced principally by fear of the Turks, had written both to the Pope and to the council on the subject of the reunion of Christendom, and both had entertained his proposals. The majority, however, of the bishops in the council maintained that this subject could not properly be discussed in Italy, and that the deliberations must take place in France, Savoy, or Basel, far from the influence of the Pope. To this Eugenius would not agree; and when the council decided against him, he resolved to assemble another council, which met first at Ferrara and afterwards at Florence.

The rest of the proceedings of the Council of Basel is simply a record of struggles with the Pope. In 1437 the council ordered the Pope to appear before them at Basel. The Pope replied by dissolving the council; the bishops, backed by the emperor and the king of France, continued their deliberations, and pronounced the Pope contumacious for not obeying them. When Eugenius tried to take away the authority of the council by summoning the opposition Council of Florence, the bishops at Basel deposed him. Eugenius replied by a severe bull, in which he excommunicated the bishops, and they answered by electing a new Pope, Amadeus, duke of Savoy, who assumed the name of Felix V. The greater part of the church adhered to Eugenius, but most of the universities acknowledged the authority of Felix and the Council of Basel. Notwithstanding the opposition of Eugenius and his adherents, the Council of Basel continued to pass laws and decrees until the year 1443; and when the bishops separated they declared publicly that they would reassemble at Basel, Lyons, or Lausanne. In 1447 Eugenius died and was succeeded by Nicholas V., who tried to bring about a reconciliation between the parties in the church. A compromise was effected, by which Felix resigned the pontificate, and the fathers of Basel having assembled at Lausanne, ratified the abdication of Felix, and directed the church to obey

Nicholas, while Nicholas confirmed by his sanction the acts and decrees of the Council of Basel.

Hefele's *Conciliengeschichte*, vol. v.; Mansi, *Concilia*, vol. xxix; Meuschen, *De Concilio Basiliensi*. The Acts of the Council are preserved in MS. in Paris and in Basel. (T. M. L.)

**BASHAN**, a country lying on the east side of the Jordan valley, towards its northern extremity, often mentioned in Jewish history. The Hebrew form of the name is בָּשָׁן or בָּשָׁן, represented in Greek by *Basán* and *Basavír* (LXX. and Epiphanius), or more frequently by *Basavaia* (Josephus, Ptolemy, Eusebius, &c.). The name is understood to be derived from a root signifying *fertile*, or, according to some, *basaltic*; and in some of the ancient versions of the Old Testament it is occasionally rendered by a word indicating fertility; thus, in Pa. xxii. 13, the LXX. gives for Bashan *κλῆμα*, Aquila gives *κλῆμα*, Symmachus, *στρωτόν*. When we first hear of this region in the days of Abraham it is occupied by the Rephaim, whose chief city is Ashteroth Karnaim (Gen. xiv. 5). These Rephaim, with kindred tribes spread over the trans-Jordanic region, were in great part subdued and supplanted by the children of Lot (Deut. ii. 10, 11, 19–21), who in their turn were invaded and displaced by the Amorites (Num. xx. 26–30). By this people, at the time of the Exodus, the whole region north of the Arnon was occupied; and they formed two kingdoms, the more northerly embracing all Bashan and a part of Gilead (Deut. iii. 8, 13; Josh. xii. 4, 5). Og, who is described as a man of gigantic stature, belonging to the race of the Rephaim, was, at the time referred to, the ruler of this kingdom; and having come out against the Israelites, he was overthrown in battle at Edrei, one of his own cities. Subsequently, his country became the allotment of the half tribe of Manasseh (Josh. xiii. 29–31).

The information given in connection with the Israelitish conquest enables us to define with considerable exactness the limits of the ancient Bashan. Towards the west it included Golan (Deut. iv. 43; Josh. xi. 8, xxi. 27), a name which to the present day has continued attached to the district, the Jaulán, lying on the east of the Jordan, in its upper course; while towards the east, it reached to Salchah (Deut. iii. 10, &c.), the modern Salkhat, situated on the south-eastern slope of the Haurán mountains. On the south it is represented as immediately adjoining the country of Gilead, whose northern boundary is known to have been the river Jarmuk, and on the north, it is expressly said to have extended to Mount Hermon (Deut. iv. 48, xxxiii. 22; Josh. xii. 5, xiii. 11, 12). Within the limits thus indicated, may be pointed out the towns and other localities mentioned as belonging to Bashan. Ashteroth, Og's metropolis, doubtless the Ashteroth Karnaim of Gen. xiv. 5, called also Beeshterah (cf. Josh. xxi. 27, and 1 Chron. vi. 71), has been sought in various places, especially in Tel Ashterah (see Newbold, *Jour. Geog. Soc.*, vol. xvi.), but has now, with much probability, been identified (by Wetstein, *Reisebericht über Haurán*, p. 110) with the well-known Busráh, the Bostra of the Latins, whose position admirably adapts it for a capital city, and whose ruins attest its ancient splendour. Edrei, already mentioned, is to be identified with Derát, on the west of Busráh (Wetstein, *op. cit.*, p. 47, 77). The position of Golan and Salchah has been indicated, while Kenath (Num. xxvii. 42) is recovered in the modern Kunawát (Porter, *Five Years in Damascus*, vol. ii. p. 111). The region of Argob will be referred to immediately.

Within the same limits lie the provinces included by Josephus in the Bashan of the Israelites (cf. *Ant. Jud.*, iv. 5, 3; ix. 8, 1; *Bell. Jud.*, ii. 6, 3; iii. 3, 5), and recognized generally by the Greek and Roman writers. They are four—Gaulonitis, Trachonitis, Auranitis, and Batanea, answering as nearly as possible to the natural divisions of

the country. The first, Gaulonitis, deriving its name from the ancient Golan, and coincident more or less exactly with the modern Jaulán already mentioned, forms the western division, extending from the Jordan lakes to the Haj road. It is spoken of as divided into two sections, the territory of Gamala, or Gamalitis, and the territory of Sogana (*Bell. Jud.*, iv. 1, 1). It forms a fertile plateau, diversified on its northern half by a range of low, richly-wooded hills, the Tell el Faraa, which descends from Mount Hermon. The second, Trachonitis (mentioned Luke iii. 1), lay east of the preceding, and adjoined the territory of Damascus, as well as Auranitis and Batanea (*Ant. Jud.*, i. 6, 4; xv. 10, 1). This leads us to the remarkable tract, now called the Lejáh, forming one of the two Trachónes, or rocky volcanic districts, lying south and east of Damascus, mentioned by Strabo (*Geog.* xvi. v. 520). Inscriptions, moreover, have been found in the Lejáh (see Burckhardt, *Travels in Syria*, p. 117), which attest that the district was called Trachón. In this province we may with confidence recognize "the region of Argob," so often mentioned in the Old Testament, as included in the country of Bashan (Deut. iii. 4, 13, 14; 1 Kings iv. 13). The arguments for this identification are,—1st, The etymology of the word Argob (see Gesenius and Fürst, *sub voce*); 2d, the descriptive term usually conjoined with the name, *chebel* Argob, indicating a tract clearly defined and measured off, and applied elsewhere to the line of the sea coast, which the boundary of the Lejáh resembles (cf. Porter, *op. cit.*, vol. ii. p. 241); 3d, by the Targumists the name Argob is rendered *Trachóna* (Lightfoot, *Chorographical Notes*, § 4). The third province, Auranitis, presents a name known both in ancient and in modern times. In Ezekiel (xlvii. 16, 18) mention is made of Haurán (in the LXX. *Αυρανίτις*), as a locality on the border of the land of Israel. The name is found also on the inscriptions of Assyria, under the form Havranu (Schrader, *Die Keil-schriften und das A. T.*, p. 237), and it is common in Arabian writers. In regard to its modern use Porter says (*Jour. Sac. Lit.*, July 1854, p. 303), "The name Haurán is at present applied by those at a distance to the whole country east of Jaulán and Jeidtr. By the people of that country, however, it is used in a much more restricted sense, and is given only to the fertile plain on the south of the Lejáh, with the narrow strip on the west. The whole of this district is perfectly flat, with little conical hills at intervals. The soil is the most fertile in Syria, admirably adapted to the production of wheat." (Cf. Burckhardt, *op. cit.*, p. 285). The fourth district is Batanea, a name obviously derived from, and often used by Josephus and others co-extensively with, the old name Bashan. It has, however, a special application to the district lying on the east of the Lejáh and of the Haurán plain, including the central masses of the Jebel ed-Dru- or Haurán mountain (apparently the Alsedanus or Alsalamus mons of Ptolemy, and perhaps, the Salmon of Pa. lrviii. 14; see Eland, *Palastina*, p. 458; Wetstein, *op. cit.*, p. 90) and its eastern slopes. To this portion of the kingdom of Bashan, the name Ard-el-Bathanyeh is still applied by the natives. Says Porter (*op. cit.*, p. 305), "One of the most intelligent Druzes I met with in my whole journey, told me the whole mountains were comprehended in the Ard-el-Bathanyeh."

The history of Bashan, after its conquest by the Israelites, merges into the general history of that nation, and of Western Asia. It is last mentioned in the Old Testament, in 2 Kings x. 33, in connection with the attacks made by Hazael, the king of Damascus, upon the territory of Israel. Throughout the Psalms and the Prophets, Bashan is celebrated for its fertility and luxuriance, its rich pastures, its strong bulls, its fatlings "of rams, of lambs, and of goats, of bullocks;" its oaks and its firs (Pa. xxii.

12; Amos iv. 1; Isa. ii. 13; Jer. l. 19; Ezek. xxxix. 18, xxvii. 6); and its extraordinary fertility is attested by the density of its population (Deut. iii. 4, 5, 14)—a density proved by the unparalleled abundance with which ruined towns and cities are now strewn over the whole country. In the disturbed period which followed the breaking up of the empire of Alexander, its possession was an object of continual contest. "Idumean princes, Nabathæan kings, Arab chiefs, ruled in their turn." The central portion of the country, Trachonitis, early became a refuge for outlaws and haunts of robbers, a character for which it is singularly fitted by nature, and which it retains to the present day. (Cf. Josephus, *Ant. Jud.*, xv. 1; xvi. 9, 2; Strabo, *Geog.*, xvi. p. 520; Gul. Tyr., *Hist.*, xv. 10.) In Arabian tradition Beshan is regarded as the country of the patriarch Job (see Abulfeda, *Hist. Antisiamica*, p. 27, 208, and esp. Wetzstein, in Delitzsch, *Das Buch Job*, p. 507, f.); and it holds a prominent place in authentic Arabian history as the seat of the dynasty of the Ghassanides (see Caussin de Perceval, *L'Histoire des Arabes*, vol. ii. 202, f.; Wetzstein, *op. cit.*, 121, f.). At the present day the Haurân is one of the seats of that singular people, the Druzes (see DRUZES).

Both in its natural and its archaeological aspects, the country of Beshan is full of interest. The Jebel ed-Drus, which rises to nearly 6000 feet in height, is a congeries of extinct volcanoes, and the products of eruption from this source, spread over the adjoining plains, have given to the soil that character of fertility for which it has been in all ages remarkable. (Cf. Lyell, *Principles of Geology*, 9th ed., p. 394.) This volcanic soil, we are told, yields on the average, in some places, eighty returns of wheat, and a hundred of barley (Wetzstein, *op. cit.*, p. 30.) The mountains themselves are richly clothed, at least on their western side, with forests of various kinds of trees, among which the evergreen oak is especially abundant. The Lejâh is one of the most remarkable regions on the earth's surface. "It is," says one of the latest observers (Burton, *Unexplored Syria*, vol. i. p. 164), "in fact a lava bed; a stone torrent poured out . . . over the ruddy yellow clay and the limestone floor of the Haurân valley, high raised by the ruins of repeated eruptions, broken up by the action of fumaroles or blow holes, and cracked and crevassed when cooling by earthquakes, and by the weathering of ages." (See also Burekhardt, *op. cit.*, p. 113; Porter's *Five Years in Damascus*, vol. ii. p. 241; Wetzstein, *op. cit.*, p. 25.)

In regard to the architectural monuments of the Haurân, the "striking feature," says Count de Vogué (*Recovery of Jerusalem*, p. 423), "is the exclusive use of stone. The country produces no wood, and the only rock which can be obtained is a basalt, very hard and very difficult to work." The walls are formed of large blocks, carefully dressed, and laid together without cement, and often let into one another with a kind of dovetail. Roofs, doors, stairs, and windows, are all of stone. This, of course, imparts to the buildings great massiveness of appearance and great solidity, and in multitudes of cases the houses, though "without inhabitant," are as perfect as when first reared. Since buildings so strong are apparently capable of enduring for any length of time, and since some of these are known, from the inscriptions upon them, to date from before the commencement of the Christian era, it is not unnatural to regard them as, in fact, the work of the earliest known inhabitants of the land, the Amorites or the Rephaim. (See Ritter, *Paläst. and Syrien*, ii. 964; Porter, *Giant Cities*, p. 79, f.) This, however, is contested, on the ground that the extant inscriptions and the architectural style point to a much later date, and must be regarded as at least unproved. (See Wetzstein, *op. cit.*, p. 103; Fergusson, in *Athenæum*, July 1870, p. 148; Burton, *op. cit.*, vol. i. p. 192.) Many inscriptions have been

found in this region,—most of them composed in Greek, a considerable number in two forms of Shemitic writing (the Palmyrenian or Aramæan, and the Sinaitic or Nabathæan), and some in an unknown character, resembling the Himyaritic. Arabic inscriptions are numerous on buildings of more recent date. The oldest recognizable Greek record bears the name of Herod the Great; and the Nabathæan kings, of the dynasty of Aretas, who reigned from about 100 a.c. at Bozrah have also left memorials.

To the works on this region above referred to the following may be added:—Seetzen, *Reisen durch Syrien*; Buckingham, *Travels among the Arab Tribes*; Graham, *Jour. Geog. Soc.*, vol. xviii.; De Vogué, *Syrie Centrale*; Waddington, *Inscriptions Grecques de la Syrie*; Freshfield, *Travels in the Central Caucasus and Bashan*. (W. TU.)

**BASHKIRS**, a people who inhabit the Russian governments of Orenburg, Perm, and Samar, and parts of Viatchka, especially on the slopes and confines of the Ural, and in the neighbouring plains. The Bashkirs are a Tatarised Finnish race, and are called *Kestyak* by the Kirghis, in allusion to their origin from a mixture of Ostyaks and Tatars. The name Bashkir or Bash-kirt appears for the first time in the beginning of the 10th century in the writings of Ibn-Foslan, who, describing his travels among the Volga-Bulgarians, mentions the Bashkirs as a warlike and idolatrous race. The name was not used by the people themselves in the 10th century, but is a mere nickname. It probably points to the fact that the Bashkirs, then as now, were distinguished by their large, round, short, and, possibly, close-cropped heads. Of European writers the first to mention the Bashkirs are Plano-Carpini and Rubruquis. These travellers, who fell in with them in the upper parts of the River Ural, call them *Pascatir*, and assert that they spoke at that time the same language as the Hungarians. Till the arrival of the Mongolians, about the middle of the 13th century, the Bashkirs were a strong and independent people, and troublesome to their neighbours, the Bulgarians and Pechenegs. At the time of the downfall of the Kazan kingdom they were in a weak state. In 1556 they voluntarily recognized the supremacy of Russia, and, in consequence, the city of Upha was founded to defend them from the Kirghis, and they were subjected to a fur-tax. In 1676 they rebelled under a leader named Seit, and were with difficulty reduced; and again in 1707, under Aldar and Ktuyom, on account of ill-treatment by the Russian officials. Their third and last insurrection was in 1735, at the time of the foundation of Orenburg, and it lasted for six years. In 1786 they were freed from taxes; and in 1798 an irregular army was formed from among them. They are now divided into thirteen cantons, and each canton into *yurts* or districts, the whole being under the jurisdiction of the Orenburg governor-general. In military matters they are subject to an Ataman, chosen from the generals of the army; but in civil affairs the *yurts* and cantons are administered by Bashkir officials. They maintain a military cordon, escort caravans through the Kirghis steppes, and are employed in various other services. By mode of life the Bashkirs are divided into settled and nomadic. The former, who are not distinguishable from the inhabitants of the Tatar villages, are engaged in agriculture, cattle-rearing, and bee-keeping, and live without want. The nomadic portion is subdivided, according to the districts in which they wander, into those of the mountains and those of the steppes. Almost their sole occupation is the rearing of cattle; and they attend to that in a very negligent manner, not collecting a sufficient store of winter fodder for all their herds, but allowing part of them to perish. The Bashkirs are usually very poor, and in winter live partly on a kind of gruel called *yartyu*, and badly prepared cheese named *skirt*. They are hospitable but suspicious, apt to plunder, and to the last degree lazy. They have

large heads, black hair, eyes narrow and flat, small foreheads, ears always sticking out, and a swarthy skin. In general, they are strong and muscular, and capable of enduring all kinds of labour and privation. They profess Mahometanism, but are little acquainted with its doctrines. In intellectual development they do not stand high.

See Semenoff, *Slovar Ross. Imp. s. v.*; Frith, "De Baskiria," in *Mém. de l'Acad. de St Petersburg*, 1822; and Florinaky, in *West-nik Evropi*, 1874.

**BASIL THE GREAT**, an eminent ecclesiastic in the 4th century. He was a leader in the Arian controversy, a distinguished theologian, a liturgical reformer; and his letters to his friends, especially those to Gregory of Nazianzus, give a great amount of information about the stirring period in which he lived. Basil came of a somewhat famous family, which gave a number of distinguished supporters to the church of the 4th century. His eldest sister, Macrina, was celebrated for her saintly life; his second brother was the famous Gregory of Nyssa; his youngest was Peter, bishop of Sebaste; and his eldest brother was the famous Christian jurist Naucratus. It has been observed that there was in the whole family a tendency to ecstatic emotion and enthusiastic piety. Basil was born about 330, at Cæsarea in Cappadocia. While he was still a child, the family removed to Pontus; but he soon returned to Cappadocia to live with his mother's relations, and seems to have been brought up by his grandmother Macrina. It was at Cæsarea that he became acquainted with his life-long friend Gregory of Nazianzus, and it was there that he began that interesting correspondence to which reference has been made. Basil did not from the first devote himself to the church. He went to Constantinople in pursuit of learning, and spent four or five years there and at Athens. It was while at Athens that he seriously began to think of the church, and resolved to seek out the most famous hermit saints in Syria and Arabia, in order to learn from them how to attain to that enthusiastic piety in which he delighted, and how to keep his body under by maceration and other ascetic devices. After this we find him at the head of a convent near Arnesi in Pontus, in which his mother Emmilia, now a widow, his sister Macrina, and several other ladies gave themselves to a pious life of prayer and charitable works. He was not ordained presbyter until 365, and his ordination was probably the result of the entreaties of his ecclesiastical superiors, who wished to use his talents against the Arians, who were numerous in that part of the country, and were favoured by the Arian emperor, who then reigned in Constantinople. In 370 Eusebius, bishop of Cæsarea, died, and Basil was chosen to succeed him. It was then that his great powers were called into action. Cæsarea was an important diocese, and its bishop was, *ex officio*, exarch of the great diocese of Pontus. Basil was threatened with confiscation of property, banishment, and even death, if he did not relax his regulations against the Arians; but he refused to yield, and in the end triumphed. He died in 379. The principal theological writings of Basil are his *De Spiritu Sancti* and his three books against Eunomius. He was a famous preacher, and we possess at least seventeen homilies by him on the Psalms and on Isaiah. His principal efforts as a reformer were directed towards the improvement of the Liturgy (the *Liturgy of the Holy Basil*), and the reformation of the monastic orders of the East. (Cf. the Benedictine editions of the works of Basil the Great.)

The name **BASIL** also belongs to several distinguished churchmen besides Basil the Great. (1.) Basil, bishop of Ancyra (336-360), a semi-Arian, highly favoured by the Emperor Constantine, and a great polemical writer; none of his works are extant. (2.) Basil of Seleucia

(fl. 448-458), a bishop who shifted sides continually in the Eutychiean controversy, and who wrote extensively; his works were published in Paris in 1622. (3.) Basil of Ancyra, fl. 787; he opposed image worship at the second council of Nicea, but afterwards retracted. (4.) Basil, the founder of a sect of mystics who appeared in the Greek Church in the 12th century (cf. Anna Comnena, *Alexiad.*, bk. 15).

**BASILICA**, a term denoting (1) in civil architecture, a court of law, or merchants' exchange, and (2) in ecclesiastical architecture, a church of similar form and arrangement.

The name *basilica*, *βασιλική* (*sc. στέγῃ or σάλας*), "a royal portico," or "hall," is evidence of a Greek origin. The portico at Athens in which the second archon, *ἀρχὴν βασιλικήν*, sat to adjudicate on matters touching religion, and in which the council of Areopagus sometimes met, was known as the *στέγῃ βασιλικῆς* or *βασιλική* (Pausan., i. 3, § 1; Demosth., *Aristogit.*, p. 776; Plato, *Charmid.*, *ad imit.*; Aristoph., *Ecclesias.*, 685). From this circumstance the term appears to have gained currency as the designation of a law-court, in which sense it was adopted by the Romans. The introduction of *basilica* into Rome was not very early. Livy expressly tells us, when describing the conflagration of the city, 210 B.C., that there were none such then,—*"neque enim tum basilicae erant"* (xxvi. 27). The earliest named is that erected by M. Porcius Cato, the censor, 183 B.C. (Liv., xxxix. 44), and called after its founder *basilica Porcia*. When once introduced this form of building found favour with the Romans. As many as twenty basilicas are recorded to have existed within the walls of Rome, erected at different periods, and bearing the names of their founders, e.g.—*Emilia, Julia, Sempronia, Ulpia* or *Trajana*, &c. The basilicas were always placed in the most frequented quarter of the city, in the immediate vicinity of a forum, and on its sunniest and most sheltered side, that the merchants and others who resorted thither might not suffer from the severity of the weather (Vitruv., *De Architect.*, v. 1). Originally, the basilicas, like the Royal Exchange in London and the Bourse at Antwerp, were unroofed, consisting of a central area surrounded simply by covered porticoes, without side walls. Subsequently, side walls were erected and the central space was covered by a roof, which was generally of timber, the beams being concealed by an arched or coved ceiling, ornamented with *lacunaria*. Some basilicas (e.g. that of Maxentius or "the Temple of Peace") were vaulted.

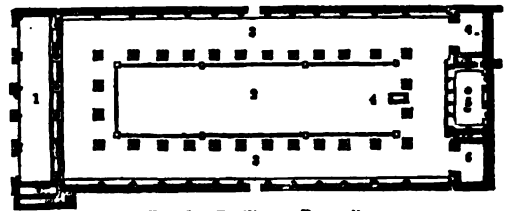

FIG. 1.—Basilica at Pompeii

- |                                      |                |
|--------------------------------------|----------------|
| 1. Portico.                          | 4. Altar.      |
| 2. Hall of Basilica.                 | 5. Tribunal.   |
| 3. Side aisles, with galleries over. | 6. Chalcidica. |

In plan the basilicas were large rectangular halls, the length of which, according to the rules laid down by Vitruvius (*ubi sup.*), was not to be more than three times or less than twice its width. In any cases where, from the necessity of the locality, the length exceeded these proportions, the excess was to be masked by the construction of small apartments (*chalcidica*) at the further end, on both sides of the tribunal. On each side of the central area was one, or sometimes, as in the Ulpian and *Æmilian* basilicas, two rows of columns. These were returned at either end, cutting off a vestibule at one extremity, and the tribunal or court proper, forming a kind of transept,



elevated above the nave, at the other. Above the aisles thus formed (*porticus*) were galleries, formed by a second row of columns supporting the roof, approached by external staircases, for the accommodation of the general public—men on one side, women on the other (Plin., *Epist.*, vi. 33). They were guarded by a parapet wall (*pluteus*) between the columns, high enough to prevent those in the galleries from being seen by those below. Sometimes, as in Vitruvius's own basilica at Fanum, and in that at Pompeii, instead of a double there was only a single row of columns, the whole height of the building, on which the roof rested. In this case the galleries were supported by square piers (*parastatae*) behind the main columns. The building was lighted with windows in the side walls, and at the back of the galleries. In the centre of the end-wall were the seats of the judge and his assessors, generally

occupying a semicircular apse, the praetor's curule chair standing in the centre of the curve. When the assessors were very numerous (according to Pliny, *u. s.*, they sometimes amounted to one hundred and eighty), they sat in two or three concentric curves arranged like the seats of a theatre. The advocates and other officials filled the rest of the raised platform, divided from the rest of the building by a screen of lattice-work (*cancelli*). In the centre of the chord of the apse stood an altar on which the *judices* took an oath to administer true justice. The tribunal sometimes ended square instead of apsidally. This is so in the basilica at Pompeii (see the plan annexed), where the tribunal is parted from the body of the hall by a *podium* bearing a screen of six columns, and is flanked by staircases to the galleries and by the *chalcidica*. The larger and more magnificent basilicas were sometimes finished with an apse at each extremity.

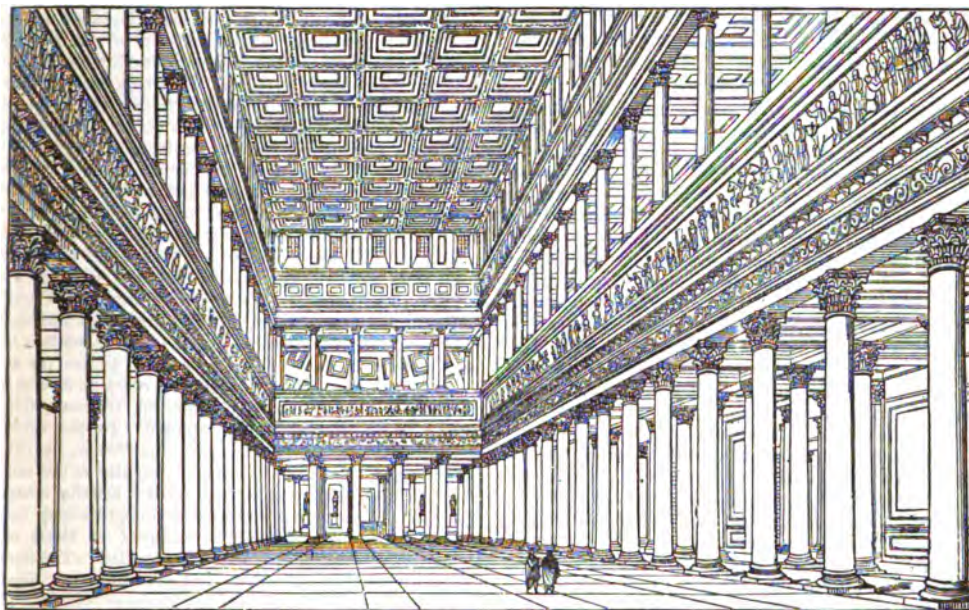

FIG. 2.—Interior view of Trajan's Basilica (*Basilica Ulpia*), as restored by Canina.

The plans of Trajan's basilica usually give this arrangement. The fragment of the ground-plan in the marble tablets preserved in the Capitol, usually called that of the Æmilian,

but really, as Canina has shown, that of the Ulpian basilica, also shows an apse, designated (*Atrium*) *Libertatis*. This, we know from many ancient authorities, was the locality

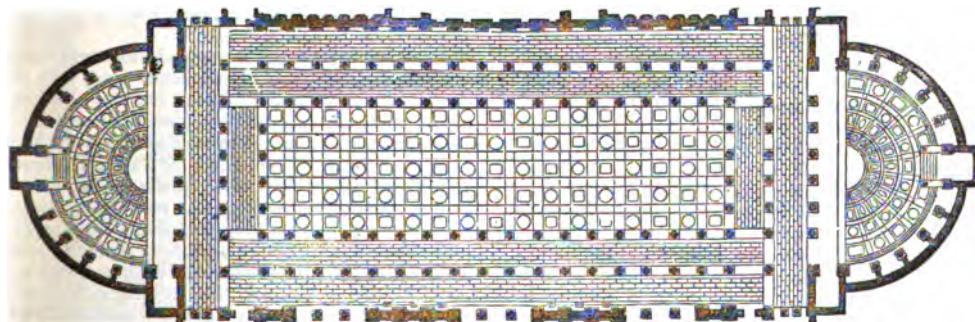

FIG. 3.—Ground-Plan of Trajan's Basilica (*Basilica Ulpia*).

for the manumission of slaves, and, therefore, the tribunal must have been at the other end, and, doubtless, also apsidal. The basilica of Trajan was one of the largest and most magnificent in Rome. From its existing remains we learn

that it was 174 feet in breadth, and more than twice as long as it was broad. (The plan and supposed internal arrangements will be seen in the annexed woodcuts from Canina.) The nave, 86 feet in breadth, was divided from

the double aisles by rows of granite columns, 35 feet high. An upper row of columns in front of the galleries above the aisles supported a ceiling, covered with plates of gilt bronze. The total internal height was about 120 feet. The walls were cased with white marble from Luna. It was paved with giallo antico and purple breccia. A side court, which enclosed the well-known memorial column to Trajan, was flanked by libraries, *Bibliotheca Græca* and *Latina* (Sidon. Apollinaris, *Epigr.*, ix. 16).



FIG. 4.—Section of the Basilica of Constantine or Maxentius (Temple of Peace).

The basilica of Maxentius (or of Constantine), usually known as the *Temple of Peace*, in the Forum at Rome, was on an entirely different plan from those already described. The internal colonnades were dispensed with, the central space being covered by a vast quadripartite brick vault, in three bays; and the aisles were roofed with three huge barrel vaults, each 72 feet in span. Columns were only used for ornament. The tribunal was apsidal. Its width was 195 feet, but it was 100 feet shorter than Trajan's basilica. The ground-plan of a small but interesting basilica, of which the foundations remain at Otricoli (Oriculum), is given by Agincourt (pl. lxxiii. No. 100). The nave is of four bays; beyond the aisles there is an additional aisle of annexed buildings or *chalcidica*: the apse is internal. A good example of a provincial basilica remains at Trèves. It is a plain hall, about 90 feet long, the walls being 100 feet high, without aisles, and it has an apsidal tribunal elevated considerably above the floor. Under the empire, when architectural magnificence reached a hitherto unparalleled height, *basilica* formed a part of the plan of the palaces erected by the emperors and nobles of Rome (Vitruv., vi. 81). A beautiful example on a small scale, the *Basilica Jovis*, has been recently excavated in the ruins of the palace of the Cæsars on the Palatine. Only the lower part of the walls remains, but the arrangements of the building are singularly perfect, even to the pierced marble *cancelli*, and throw the clearest light on the construction of these halls.

On the establishment of Christianity as the imperial religion, these vast halls furnished exactly what was wanted for the religious assemblies of the Christian community. The basilica was, in fact, a ready-made church, singularly adapted for its new purpose. The spacious nave accommodated the ordinary congregations, the galleries or aisles the females and the more dignified worshippers; while the raised tribunal formed the *chœra*, or sanctuary, separated by lattice-work from the less sacred portion below, the bishop and his clergy occupying the semicircular apsis. The prætor's curule chair became the episcopal throne, the curved bench of his assessors the seat for the presbyters of the church. The inferior clergy, readers, and singers took the place of the advocates below the tribunal; while on the site of the heathen altar rose the holy table of the Eucharistic feast, divided from the nave by its protecting lattice-work screen, from which were suspended curtains guarding the sacred mysteries from the intrusive gaze of the profane.

The words of Ausonius to the Emperor Gratian, in which he speaks of "the basilicas once full of business, but now

of prayers for the emperor's preservation" (*Græc. Actio pro Consulatu*), are a testimony to the general conversion of these civil basilicas into Christian churches. We know this to have been the case with the basilicas of St Cross (St. Croce in Gerusalemme) and St Mary Major's at Rome, which were halls in the Sessorian and Liberian palaces respectively, granted by Constantine to the Christians. We may adduce also as evidence of the same practice a passage from the theological romance known as *The Recognitions of Clement* (bk. x. ch. 71), probably dating from the early half of the 3d century, in which we are told that Theophilus of Antioch, on his conversion by St Peter, made over "the basilica of his house" for a church. But however this may have been, with, perhaps, the single exception of St Cross, the existing Christian basilicas were erected from the ground for their sacred purpose. At Rome the columns, friezes, and other materials of the desecrated temples and public buildings furnished abundant materials for their construction. The decadence of art is plainly shown by the absence of rudimentary architectural knowledge in these reconstructions. Not only are columns of various heights and diameters made to do duty in the same colonnade, but even different orders stand side by side—(e.g., Ionic, Corinthian, and Composite at St Mary's in the Trastevere); while pilasters assume a horizontal position, and serve as entablatures, as at St Lawrence's. There being no such quarry of ready-worked materials at Ravenna, the noble basilicas of that city are free from these defects, and exhibit greater unity of design and harmony of proportions. In all cases, however, the type of the civil basilica, which had proved so suitable for the requirements of Christian congregations, was adhered to with remarkable uniformity.

An early Christian basilica may be thus described in its main features.—A porch supported on pillars (as at St Clement) gave admission into an open court or *atrium*, surrounded by a colonnaded cloister (St Clement, Old St Peter's, St Ambrose at Milan, Parenzo). In the centre of the court stood a cistern or fountain (*cantharus, phiale*), for drinking and ablutions. In close contiguity to the atrium, often to the west, was the baptistery, usually octagonal (Parenzo). The church was entered through a long narrow porch (*narthex*), beyond which penitents, or those under ecclesiastical censure, were forbidden to pass. The narthex was sometimes internal (St Agnes), sometimes an external portico (St Lawrence's, St Paul's). Three or four lofty doorways, according to the number of the aisles, set in marble cases, gave admission to the church. The doors themselves were of rich wood, elaborately carved with scriptural subjects, or of bronze similarly adorned and often gilt. Magnificent curtains, frequently embroidered with sacred figures or scenes, closed the entrance, keeping out the heat of summer and the cold of winter.

The interior consisted of a long and wide nave, often 80 feet across, terminating in a semicircular apse, with one or sometimes (St Paul's, Old St Peter's, St John Lateran) two aisles on each side, separated by colonnades of marble pillars supporting horizontal entablatures (Old St Peter's, St Mary Major's, St Lawrence's) or arches (St Paul's, St Agnes, St Clement, the two basilicas of St Apollinaris at Ravenna). Above the pillars the clerestory wall rose to a great height, pierced in its upper part by a range of plain round-headed windows. The space between the windows and the colonnade (the later triforium-space) was usually decorated with a series of mosaic pictures in panels (Old St Peter's, St Paul's, St Mary Major's, St Apollinaris within the walls at Ravenna). The upper galleries of the secular basilicas were not usually adopted in the West, but we have examples of this arrangement at St Agnes, St Lawrence's, and the Quattro Santi Coronati. They are much more frequent in the East. The colonnades sometimes extended quite to the end of

the church (St Mary Major's), sometimes ceased some little distance from the end, thus forming a transverse aisle or transept (St Paul's, Old St Peter's, St John Lateran). Where this transept occurred it was divided from the nave by a wide arch, the western face and soffit of which were richly decorated with mosaics. Over the crown of the arch we often find a bust of Christ or the holy lamb lying upon the altar, and, on either side, the evangelistic symbols, the seven candlesticks, and the twenty-four elders. Another arch spanned the semicircular apse, in which the church always terminated. This was designated the *arch of triumph*, from the mosaics that decorated it representing the triumph of the Saviour and His church. The conch or semi-dome that covered the apse was always covered with mosaic pictures on a gold ground, usually paintings of our Lord, either seated or standing, with St Peter and St Paul, and other apostles and saints, on either hand. The beams of the roof were generally concealed by a flat ceiling, richly carved and gilt. The altar, standing in the centre of the chord of the apse on a raised platform, reached by flights of steps, was rendered conspicuous by a lofty canopy supported by marble pillars (*ciborium, baldacchino*), from which depended curtains of the richest materials. Beneath the altar was the *confessio*, a subterranean chapel, containing the body of the patron saint, and relics of other holy persons. This was approached by descending flights of steps from the nave or aisles. The *confessio* in some cases reproduced the original place of interment of the patron saint, either in a catacomb-chapel or in an ordinary grave, and thus formed the sacred nucleus round which the church arose. We have good examples of this arrangement at St Peter's, St Paul's, St Pudenziana, and St Lawrence. It was copied, as we will see hereafter, in the original cathedral of Canterbury. The bishop or officiating presbyter advanced from his seat in the centre of the semicircle of the apse to the eastern side (ritually) of the altar, and celebrated the Eucharist with his face to the congregation below. At the foot of the altar steps a raised platform occupying the upper portion of the nave formed a choir for the singers, readers, and other inferior clergy. This oblong space was separated from the aisles and from the western portion of the nave by low marble walls or railings. From these walls projected *ambones*, or pulpits with desks, also of marble, ascended by steps. That for the reader of the gospel was usually octagonal, with a double flight of steps westward and eastward. That for the reader of the epistle was square or oblong.

The exterior of the basilicas was usually of a repulsive plainness. The vast brick walls were unrelieved by orna-

ment, without any compensating grace of outline or beauty of proportion. An exception was made for the west front,

which was usually covered with plates of marble mosaics or painted stucco (Old St Peter's, St Lawrence's). This part was frequently crowned with a hollow projecting cornice (St Lawrence's, *Ara Caeli*). But in spite of any decorations the external effect of a basilica must always have been heavy and unattractive. The annexed view of St Apollinaris in Classe at Ravenna affords a typical example.

To pass from general description to individual churches, the first place must be given, as the earliest and grandest examples of the type, to the world-famous Roman basilicas; those of St Peter, St Paul, and St John Lateran, "*omnium urbis et orbis ecclesiarum mater et caput*." It is true that no one of these exists in its original form, Old St Peter's having been entirely removed in the 16th century to make room for its magnificent successor; and both St Paul's and St John Lateran having been greatly injured by fire, and the last named being so completely modernized as to have

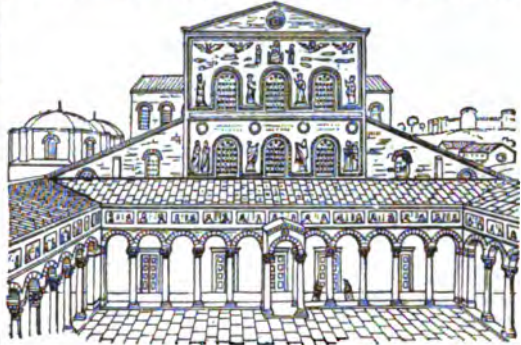

FIG. 6.—Façade of old St Peter's, Rome.

lost all interest. Of the two former, however, we possess drawings, and plans, and minute descriptions, which

give an accurate conception of the original buildings. To commence with St Peter's, from the woodcuts annexed it will be seen that the church was entered through a vast colonnaded atrium, 212 feet by 235 feet, with a fountain in the centre,—the atrium being preceded by a porch mounted by a noble flight of steps. The church was 212 feet wide by 380 feet long; the nave, 80 feet in width, was six steps lower than the side aisles, of which there were two on each side. The four dividing colonnades were each of twenty-two Corinthian columns. Those next the nave supported horizontal entablatures. The inner colonnades bore arches, with a second clerestory. The main

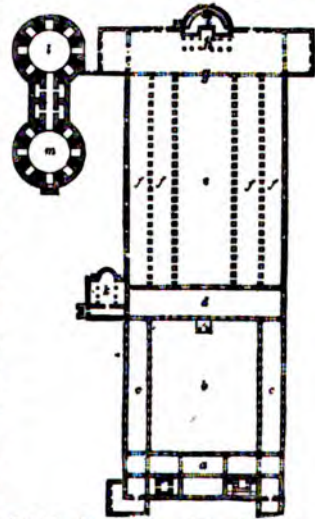

FIG. 7.—Ground-Plan of the original Basilica of St Peter's at Rome.

- |               |   |
|---------------|---|
| a, Porch.     | A, Altar, protected by a double screen.   |
| b, Atrium.    | t, Bishop's throne in centre of the apse. |
| c, Cloisters. | k, Sacristy.                              |
| d, Narthex.   | l, Tomb of Honorius.                      |
| e, Nave.      | m, Church of St. Andrew.                  |
| f, f, Aisles. |   |
| g, Bema.      |   |



FIG. 5.—Exterior view of S. Apollinaris in Classe, Ravenna.

ment, without any compensating grace of outline or beauty of proportion. An exception was made for the west front,

which was usually covered with plates of marble mosaics or painted stucco (Old St Peter's, St Lawrence's). This part was frequently crowned with a hollow projecting cornice (St Lawrence's, *Ara Caeli*). But in spite of any decorations the external effect of a basilica must always have been heavy and unattractive. The annexed view of St Apollinaris in Classe at Ravenna affords a typical example.

containing mosaics, and had windows above. The transept projected beyond the body of the church,—a very unusual arrangement. The apse, of remarkably small dimensions, was screened off by a double row of twelve wreathed columns of Parian marble, of great antiquity, reported

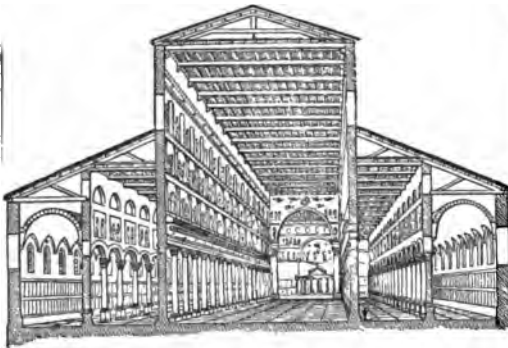

FIG. 8.—Sectional view of the old Basilica of St Peter, before its destruction in the 16th century.

to have been brought from Greece, or from Solomon's Temple. The pontifical chair was placed in the centre of the curve of the apse, on a platform raised several steps above the presbytery. To the right and left the seats of the cardinals followed the line of the apse. At the centre of the chord stood the high altar beneath a ciborium, resting on four pillars of porphyry. Beneath the altar was the subterranean chapel, the centre of the devotion of so large a portion of the Christian world, believed to contain the remains of St Peter; a vaulted crypt ran round the foundation wall of the apse in which many of the popes were buried. The roof showed its naked beams and rafters.

The basilica of St Paul without the walls, dedicated 324 A.D., rebuilt 388–423, remained in a sadly neglected state, but substantially unaltered, till the disastrous fire of 1823, which reduced the nave to a calcined ruin. Its plan and dimensions were almost identical with those of St Peter's, as will be seen from the annexed woodcuts. Its double aisles were formed by four colonnades, each of twenty Corinthian pillars, 33 feet high, all supporting arches. Of these pillars twenty-four were of the best period of Roman art, taken from the mausoleum of Augustus, or from the basilica Æmilia. The contrast between them and those of the 5th century, standing side by side with them, shows how greatly art had declined. As at St Peter's, the walls above the arches were lined with a double row of mosaic panels, below which was a band of circles containing portraits of the popes, from St Peter downwards. The transept was parted from the nave by a solid wall, with openings pierced in it, and in later times was divided down the middle by a transverse colonnade. The high

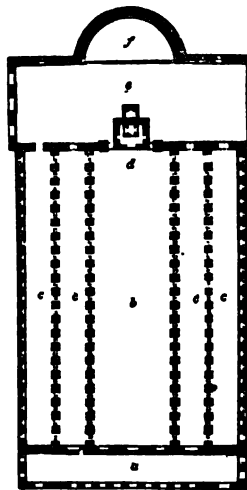

FIG. 9.—Ground-Plan of St Paul's, Rome, before its destruction by fire.

1, Narthex. 4, Alter.  
2, Nave. 5, Dome.  
3, Side aisles. 7, Apse.

altar rose above a crypt, or *confessio*, traditionally believed to be the catacomb of Lucina, a noble Roman Christian matron, to which the body of the apostle Paul had been removed 251 A.D. The narthex was external. St Paul's had completely lost its atrium. The bronze doors, covered with scriptural reliefs, had been brought from Constantinople.

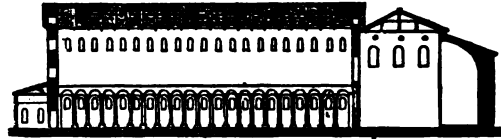

FIG. 10.—Section of the Basilica of St Paul, Rome.

The only parts of the modernized five-aisled basilica of St John Lateran (of which we have a plan in its original state, Agincourt, pl. lxxiii. No. 22) which retain any interest, are the double vaulted aisle which runs round the apse, a most unusual arrangement, and the baptistery. The latter is an octagonal building standing some little distance from the basilica to the south. Its roof is supported by a double range of columns, one above the other, encircling the baptismal basin sunk below the floor.

Of the three-aisled basilicas the best example is the Liberian or St Mary Major's; dedicated 365, and reconstructed 432 A.D. Its internal length to the chord of the apse is 250 feet, by 100 feet in breadth. The Ionic pillars of grey granite, uniform in style, twenty on each side, form a colonnade of great dignity and beauty, unfortunately broken towards the east by intrusive arches opening into chapels. The clerestory, though modern, is excellent in style and arrangement. Corinthian pilasters divide the windows, beneath which are very remarkable mosaic pictures of subjects from Old Testament history, generally supposed to date from the pontificate of Sixtus III., 432–440. The face of the arch of triumph presents also a series of mosaics illustrative of the infancy of our Lord, of great value in the history of art. The apse is of later date, reconstructed by Paschal I in 818.

The Sessorian basilica, now St Cross (Santa Croce in Gerusalemme), is of exceptional arrangement. Originally a hall of the palace known as *Sessorium*, it was granted by Constantine for the purposes of Christian worship, and a vast apse, nearly the whole breadth of the hall, was added at the east end. The side walls are pierced by two tiers of large arched openings, originally communicating with a second range of aisles. Of these the lower range has been built up, but the upper is still open, forming immense windows.

Among the remaining basilicas of Rome those of St Lawrence (S. Lorenzo fuori le Mura) and St Agnes deserve special mention, as exhibiting a gallery corresponding to those of the civil basilicas and to the later triforium, carried above the aisles and returned across the west end. The architectural history of St Lawrence's is curious. When originally constructed, 578–590, it consisted of a short nave of six bays, with an internal narthex the whole height of the building. In the 13th century Honorius III. disorientated the church, by pulling down the apse, and erecting a nave of twelve bays on its site and beyond it, thus converting the original nave into a square-ended choir, the level being much raised, and the magnificent Corinthian columns half buried. As a consequence of the church being thus shifted completely round, the face of the arch of triumph, turned away from the present entrance, but towards the original one, is invested with the usual mosaics (Agincourt, pl. xxviii. Nos. 29, 30, 31). The basilica of St Agnes, 625–638, of which we give a plan and section, is a small but interesting building, much like what St Lawrence's must have been before it was altered. From

the fall of the ground the upper galleries are on a level with the road at the east end, and were originally entered from

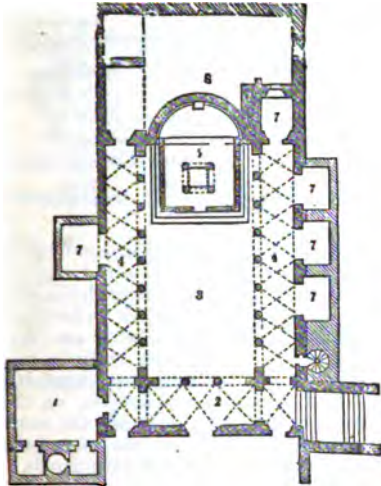

FIG. 11.—Ground-Plan of Basilica of St Agnes at Roma.

- |                              |             |          |                                      |           |                     |                          |
|------------------------------|-------------|----------|--------------------------------------|-----------|---------------------|--------------------------|
| 1. Steps down to the church. | 2. Narthex. | 3. Nave. | 4. Side aisles with galleries above. | 5. Altar. | 6. Bishop's throne. | 7, 7, 7. Modern chapels. |
|------------------------------|-------------|----------|--------------------------------------|-----------|---------------------|--------------------------|

it. St Cross originally had similar galleries above the arcade.

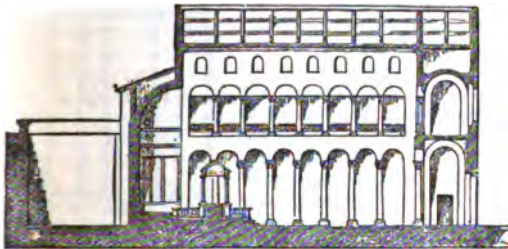

FIG. 12.—Section of Basilica of St Agnes at Roma.

Though inferior in size, and later in date than most of the basilicas already mentioned, that of St Clement is not surpassed in interest by any one of them. This is due to its having retained its original ritual arrangements and church-fittings more perfectly than any other. These fittings have been removed from the earlier church, lying below the existing building, which at some unknown date and for some unrecorded reason, was abandoned, filled up

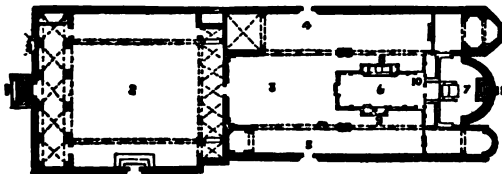

FIG. 13.—Plan of Basilica of St Clement in Roma.

- |          |           |         |                  |                     |                     |          |                |                 |               |                      |
|----------|-----------|---------|------------------|---------------------|---------------------|----------|----------------|-----------------|---------------|----------------------|
| 1. Porch | 2. Atrium | 3. Nave | 4. Aisle for men | 5. Aisle for women. | 6. Chorus cantorum. | 7. Altar | 8. Gospel ambo | 9. Epistle ambo | 10. Confessio | 11. Bishop's throne. |
|----------|-----------|---------|------------------|---------------------|---------------------|----------|----------------|-----------------|---------------|----------------------|

with earth, and a new building erected upon it as a foundation. The most probable account is that the earlier church was so completely overwhelmed in the ruin of the city in 1084, when Robert Guiscard burnt all the public buildings from the Lateran to the Capitol, that it was found simpler

and more convenient to build a new edifice at a higher level, than to repair the old one. The annexed plan and view show the peculiarities of the existing building. The church is preceded by an atrium, the only perfect example remaining in Rome, in the centre of which is the *cantarus*, or fountain for ablutions. The atrium is entered by a portico made up of earlier fragments very carelessly put together. The *chorus cantorum*, which occupies about one-third of the nave is enclosed by a low marble screen, about 3 feet high, a work of the 9th century, preserved from the old church, but newly arranged. The white marble slabs are covered with patterns in low relief, and are decorated with ribbons of glass mosaic of the 13th century. These screen-walls stand quite free of the pillars, leaving a passage between. On the ritual north stands the gospel-ambo, of octagonal form, with a double flight of steps westwards and



FIG. 14.—Interior of St Clement, Rome.

eastwards. To the west of it stands the great Paschal candlestick, with a spiral shaft, decorated with mosaic. Opposite, to the south, is the epistle-ambo, square in plan, with two marble reading-deaks facing east and west, for the reading of the epistle and the gradual respectively. The sanctuary is raised two steps above the choir, from which it is divided by another portion of the same marble screen. The altar stands beneath a lofty *ciborium*, supported by marble columns, with a canopy on smaller shafts above. It retains the rods and rings for the curtains to run on. Behind the altar, in the centre of the curved line of the apse is a marble episcopal throne, bearing the monogram of Anastasius who was titular cardinal of this church in 1108. The couch of the apse is inlaid with mosaics of quite the end of the 13th century. The subterranean church, disinterred by the zeal of Father Mullooly, the prior of the adjacent Irish Dominican convent, is supported by columns of very rich marble of various kinds. The aisle walls, as well as those of the narthex, are covered with fresco-paintings, of various dates from the 7th to the 11th century, in a marvellous state of preservation. (See *St Clement, Pope and Martyr, and his Basilica in Rome*, by Joseph Mullooly, O.P., Rome, 1873).

Out of Rome the most remarkable basilican churches are the two dedicated to St Apollinaris at Ravenna. They are of smaller dimensions than those of Rome, but the design and proportions are better. The cathedral of this city, a noble basilica with double aisles, erected by Archbishop Ursus, 400 A.D. (Agincourt, pl. xxiii, No. 21), was unfortunately destroyed on the erection of the present tasteless building. Of the two basilicas of St Apollinaris, the earlier, S. Apollinare Nuovo, originally an Arian church erected by Theodoric, 493-525, measuring 315 feet in length by 115 feet in breadth, has a nave 61 feet wide, separated from the single aisles by colonnades of twenty-two pillars, supporting arches, a small prismatic block bearing a sculptured cross intervening with very happy effect between the capital and the arch. The clerestory wall is not stilted to the excessive height of the Roman examples. Below the windows a continuous band of saintly

figures, male on one side and female on the other, advancing in stately procession towards Our Lord and the Virgin Mother respectively, affords one of the most beautiful examples of mosaic ornamentation to be found in any church. The design of the somewhat later and smaller church of St Apollinaris in Classe, 538-549 A.D., measuring 216 feet by 104 feet, is so similar that they must have proceeded from the same architect (Agincourt, pl. lxxiii, No 35).

The cathedral on the island of Torcello near Venice, originally built in the 7th century, but largely repaired circa 1000 A.D., deserves special attention from the fact that it preserves, in a more perfect state than can be seen elsewhere, the arrangements of the seats in the apse. The bishop's throne occupies the centre of the arc, approached by a steep flight of steps. Six rows of stone benches for the presbyters, rising one above another like the seats in a theatre, follow the curve on either side,—the whole being singularly plain and almost rude. The altar stands on a



FIG. 15.—Arches of St Apollinare Nuovo, Ravenna.

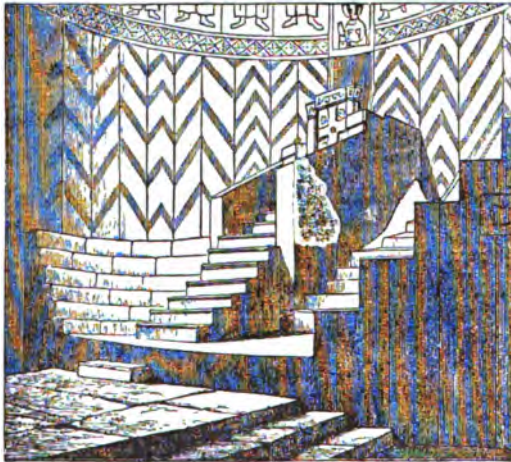

FIG. 16.—Apsé of Basilica, Torcello, with Bishop's throne and seats for the clergy. From a drawing by the late Lady Palgrave.

platform; the sanctuary is divided from the nave by a screen of six pillars. The walls of the apse are inlaid with plates of marble. The church is 125 feet by 75 feet. The narrow aisles are only 7 feet in width.

Another very remarkable basilica, less known than it deserves to be, is that of Parenzo in Istria, circa 542 A.D. Few basilicas have sustained so little alteration. From the annexed ground-plan it will be seen that it retains its atrium, and a baptistery, square without, octagonal within, to the west of it. Nine pillars divide each aisle from the nave, some of them borrowed from earlier buildings. The capitals are Byzantine. The choir occupies the three easternmost bays. The apse, as at Torcello, retains the bishop's throne and the bench for the presbyters apparently unaltered. The mosaics are singularly gorgeous, and the apse walls, as at Torcello, are inlaid with rich marble and mother-of-pearl. The dimensions are small.—121 feet by 32 feet. (See *Kunstdenkmale des Oesterreichischen Kaiserthums*, by Dr G. Heider and others).

In the Eastern church, though the erection of St Sophia at Constantinople introduced a new type which almost

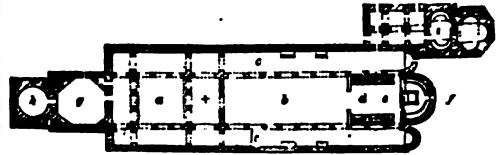

FIG. 17.—Ground-Plan of Cathedral of Parenzo, Istria.

- |                       |                     |                         |
|-----------------------|---------------------|-------------------------|
| e. Cloistered atrium. | d. Chorus cantorum. | A. Belfry.              |
| + Narthex.            | e. Altar.           | 4. Chapel of St Andrew. |
| h. Nave.              | f. Bishop's throne. |                         |
| g. Aisles.            | g. Baptistry.       |                         |

entirely superseded the old one, the basilican form, or as it was then termed *dromical*, from its shape being that of a race-course (*dromos*), was originally as much the rule as in the West. The earliest church of which we have any clear account, that of Paulinus at Tyre, 313-322 A.D., described by Eusebius (*H. E.*, x. 4, § 37), was evidently basilican, with galleries over the aisles, and had an atrium in front. That erected by Constantine at Jerusalem, on the site of the Holy Sepulchre, 333, followed the same plan (Euseb., *Vit. Const.*, iii. c. 29), as did the original churches of St Sophia and of the Apostles at Constantinople. Both these buildings have entirely passed away, but we have an excellent example of an Oriental basilica of the same date still standing in the church of the Nativity at Bethlehem, rebuilt by Justinian in the 6th century. Here we find an oblong atrium, a vestibule or narthex, double aisles with Corinthian columns, and a transept, each end of which terminates in apse, in addition to that in the usual position. Beneath the centre of the transept is the subterranean church of the Nativity (De Vogué, *Les Eglises de la Terre Sainte*, p. 46).

Constantinople still preserves a basilican church of the 6th century, that of St John Studios, 463, now a mosque. It has a nave and side aisles divided by columns supporting a horizontal entablature, with another order supporting arches forming a gallery above. There is the usual apsidal termination. The chief difference between the Eastern and Roman basilicas is in the magnitude of the galleries. This is a characteristic feature of Eastern churches, the galleries being intended for women, for whom privacy was more studied than in the West (Salzenberg, *Altchrist. Bau Denkmale von Constantinople*).

Other basilican churches in the East which deserve notice are those of the monastery of St Catherine on Mount Sinai built by Justinian, that of Dana between Antioch and Bir of the same date, St Philip at Athens, Bozrah in Arabia, Xanthus in Lycia, and the very noble church of St Demetrius at Thessalonica. Views and descriptions of most of these may be found in Texier and Pullan's *Byzantine Architecture*, Couchaud's *Choix d'Eglises Byzantines*, and the works of the count de Vogué. We may refer to Fergusson's *History of Architecture* for views and plans and description of the very interesting early miniature Christian basilicas, some of which are probably the earliest existing Christian buildings in the Mediterranean provinces of Africa. The same work (p. 640) also gives an account of the early French basilica, dating from the

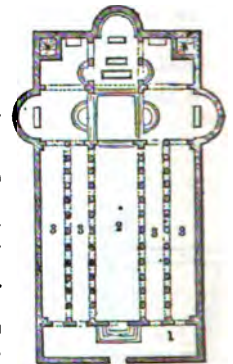

FIG. 18.—Plan of church of the Nativity, Bethlehem.

1. Narthex. 2. Nave. 3. 4. Aisles.

6th or 7th century, known as the *Basse Œuvre* at Beauvais ; as well as (pp. 550-552) of those belonging to the 8th or 9th century, in the neighbourhood of the Lake of Constance at Reichenan and Romain Motier, and at Grauson on the Lake of Neufchâtel.

The first church built in England under Roman influence was the original Saxon cathedral of Canterbury. From the annexed ground-plan, as conjecturally restored by Professor

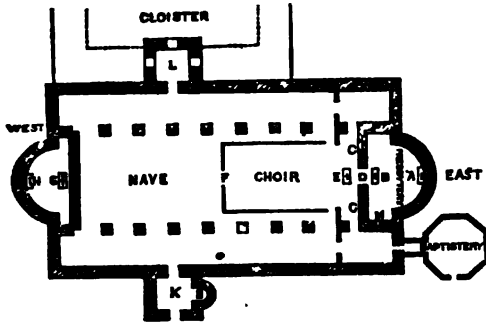

FIG. 19.—Ground-Plan of the original Cathedral at Canterbury, as restored by Willis.

- |                       |                                   |
|-----------------------|-----------------------------------|
| A. High altar.        | G. Our Lady's altar               |
| B. Altar of our Lord. | H. Bishop's throne.               |
| C. C. Steps to crypt. | K. South tower with altar.        |
| D. Crypt.             | L. North tower containing school. |
| E. Chorus cantorum    | M. Archbishop Odo's tomb.         |

Willis from Eadmer's description, we see that it was an aisled basilica, with an apse at either end, containing altars standing on raised platforms approached by steps. Beneath the eastern platform was a crypt, or *confessio*, containing relics, "fabricated in the likeness of the confessional of St Peter at Rome" (Eadmer). The western apse, dedicated to the Blessed Virgin, contained the bishop's throne. From this and other indications Willis thinks that this was the original altar end, the eastern apse being a subsequent addition of Archbishop Odo, circa 950, the church having been thus turned from west to east, as at the already-described basilica of St Lawrence at Rome. The choir, as at St Clement's, occupied the eastern part of the nave, and like it was probably enclosed by breast-high partitions. There were attached towers to the north and south of the nave. The main entrance of the church was under that to the south. At this *entrance*, according to Eadmer, "all disputes from the whole kingdom, which could not legally be referred to the king's court, or to the hundreds and counties, received judgment." The northern tower contained a school for the younger clergy.

There remains one other English basilican church to be mentioned, that of Brixworth in Northamptonshire, probably erected by Sarulphus, abbot of Peterborough, circa 690 A.D. It consisted of a nave divided from its aisles by quadrangular piers supporting arches turned in Roman brick, with small clerestory windows above, a short chancel terminating in an apse, outside which, as at St Peter's at Rome, ran a circumscribing crypt entered by steps from the chancel. At the west end was a square tower, the lower story of which formed a porch.

Authorities.—Vitruvius, *De Architectura*, v. 1 ; the same, translated, with notes, by W. Wilkins, R.A.; Gall, *Pompeiana*; Montfaucon, *Antiquité Égyptienne*, iii. 178; Canina, *Edificii di Roma Antica*; Donalson, *Architectura Numismatica*; Ciampini, *Veteri Monumenti*; Allatius, *De Recont. Græc. Templis*, ep. ii. § 8; Seroux d'Agincourt, *L'Histoire de l'Art par les Monuments*; Bunsen and Plattner, *Beschreibung der Stadt Rom*; Gutensohn and Knapp, *Basiliken*; Hübsch, *Altchristliche Kirche*; Letarouilly, *Édifices de Rome moderne*; Von Quast, *Altchristliche Bauwerke von Ravenna*; Texier and Follen, *Byzantine Architecture*; De Vogue, *Églises de la Terre Sainte*; Courband, *Églises Byzantines*; Ferguson, *History of Architecture*; Milman, *History of Christianity*, ii. 289-342; iii. 878. (E. V.)

BASILICA, a code of law, drawn up in the Greek language, with a view to put an end to the uncertainty which prevailed throughout the empire of the East in the 9th century as to the authorized sources of law. This uncertainty had been brought about by the conflicting opinions of the jurists of the 6th century as to the proper interpretation to be given to the legislation of the Emperor Justinian, from which had resulted a system of teaching which had deprived that legislation of all authority, and the imperial judges at last were at a loss to know by what rules of law they were to regulate their decisions. An endeavour had been made by the Emperor Leo the Isaurian to remedy this evil, but his attempted reform of the law had been rather calculated to increase its uncertainty; and it was reserved for Basilus the Macedonian to show himself worthy of the throne, which he had usurped, by purifying the administration of justice and once more reducing the law into an intelligible code. There has been considerable controversy as to the part which the Emperor Basilus took in framing the new code. There is, however, no doubt that he abrogated in a formal manner the ancient laws, which had fallen into desuetude, and the more probable opinion would seem to be, that he caused a revision to be made of the ancient laws which were to continue in force, and divided them into forty books, and that this code of laws was subsequently enlarged and distributed into sixty books by his son Leo the Philosopher. A further revision of this code is stated to have been made by Constantinus Porphyrogenitus, the son and successor of Leo, but this statement rests only on the authority of Theodorus Balsamon, a very learned canonist of the 12th century, who, in his preface to the *Nomocanon* of Patriarch Photius, cites passages from the Basilica; which differ from the text of the code as revised by the Emperor Leo. The weight of authority, however, is against any further revision of the code having been made after the formal revision which it underwent in the reign of the Emperor Leo, who appointed a commission of jurists under the presidency of Sympathius, the captain of the body-guard, to revise the work of his father, to which he makes allusion in the first of his *Novellæ*. This latter conclusion is the more probable from the circumstance, that the text of the code, as revised by the Emperor Leo, agrees with the citations from the Basilica which occur in the works of Michael Psellus and Michael Attalates, both of them high dignitaries of the court of Constantinople, who lived a century before Balsamon, and who are silent as to any second revision of the code having taken place in the reign of Constantinus Porphyrogenitus, as well as with other citations from the Basilica, which are found in the writings of Mathæus Blastares and of Constantinus Hermenopulos, both of whom wrote shortly after Balsamon, and the latter of whom was far too learned a jurist and too accurate a lawyer to cite any but the official text of the code.

Authors are not agreed as to the origin of the term Basilica, by which the code of the Emperor Leo is now distinguished. The code itself appears to have been originally entitled *The Revision of the Ancient Laws* (*ἡ ἀναβάθρα τῶν παλαιῶν νόμων*); next there came into use the title *ἡ ἐξηκοντάβιβλος*, derived from the division of the work into sixty books: and finally, before the conclusion of the 10th century, the code came to be designated *δ βασιλικός*, or *τὰ βασιλικὰ*, being elliptical forms of *δ βασιλικὸς νόμος* and *τὰ βασιλικὰ νόμματα*, namely the Imperial Law or the Imperial Constitutions. This explanation of the term "Basilica" is more probable than the derivation of it from the name of the father of the Emperor Leo, inasmuch as the Byzantine jurists of the 11th and 12th centuries ignored altogether the part which the Emperor Basilus had taken in initiating the legal reforms,

which were completed by his son; besides the name of the father of the Emperor Leo was written βασιλευς, from which substantive, according to the genius of the ancient Greek language, the adjective βασιλικός could not well be derived.

No perfect MS. has been preserved of the text of the Basilica, and the existence of any portion of the code seems to have been ignored by the jurists of Western Europe, until the important bearing of it upon the study of the Roman law was brought to their attention by Viglius Zuichemus, professor of the Roman law in the university of Padua, in his preface to his edition of the Greek *Paraphrases of Theophilus*, published in 1538. A century, however, elapsed before an edition of the sixty books of the Basilica, as far as the MSS. then known to exist supplied materials, was published in seven volumes, by Carolus Annibal Fabrotus, under the patronage of Louis XIII. of France, who assigned an annual stipend of two thousand livres to the editor during its publication, and placed at his disposal the royal printing-press. This edition, although it was a great undertaking and a work of considerable merit, was a very imperfect representation of the original code. A newly restored, and far more complete text of the sixty books of the Basilica, has recently issued from the press of Johannes Ambrosius Barth at Leipzig, in six volumes, edited by Professor Charles William Ernest Heimbach of the university of Jena, assisted by his brother Gustavus Ernest Heimbach. This is one of the most important literary works of the 19th century. The learned editor lived long enough to witness the completion of the text of the Basilica by the publication of the fifth volume in 1850. He died in 1856, leaving behind him a valuable historical introduction to the code, and a manual of its contents, which are printed in the sixth and last volume, published at Leipzig in 1870. Several MSS., which contain portions of the code or of works bearing directly on the code, have been available for this edition, which were not accessible to Fabrotus when he published his edition in 1647. Amongst others may be mentioned—MS. Cotelin 151, of the 11th century, now in the Bibliothèque Nationale in Paris, which came direct from Mount Athos into the hands of Chancellor Seguir, and which contains a general index of the contents of the sixty books of the Basilica; MS. Cotelin 152, of the 18th century, also in the Bibliothèque Nationale in Paris; a Palimpsest MS. of the Holy Sepulchre (τοῦ ἁγίου τάφου), which was discovered in 1838 by Dr C. E. Zacharias von Lingenthal, in the palace of the patriarch of Jerusalem in Constantinople. The text of four books of the Code has been restored by Dr C. E. Zacharias von Lingenthal from this MS., and is printed in an appendix to the third volume of Heimbach's edition. A further MS. deserves notice, being No. 858 in the Vatican Library at Rome; it belongs to the 14th century, and is the only MS. which contains the work known as *Tipicinus*. This MS. has been very carefully collated by Gustavus Ernest Heimbach, and the text of a portion of Tipicinus has been printed from this MS. in the appendix to the second volume of Heimbach's edition, the remaining portions of the work having been incorporated by Heimbach into the text of the restored code. It may seem strange that so important a body of law as the Basilica should not have come down to us in its integrity, but a letter has been preserved, which was addressed by Mark the patriarch of Alexandria to Theodoros Balsamon, from which it appears that copies of the Basilica were in the 12th century very scarce, as the patriarch was unable to procure a copy of the work. The great bulk of the code was an obstacle to the multiplication of copies of it, whilst the necessity for them was in a great degree superseded by the publication from time to time of synopses and encheiridia of its contents, composed by the most eminent jurists, of which a very full account will be found in the *Histoire des Droits Byzantins*, by the advocate Mortreuil, published in Paris in 1846.

**BASILICATA**, or, as it is also called, **POTENZA**, a province of Italy, bounded on the N. by Capitanata, N.E. by Terra di Bari, E. by Otranto and the Gulf of Taranto, S. by Calabria Citra, S.W. by the Mediterranean, W. by Principato Citra, and N.W. by Principato Ultra. It has an area of 4120 English square miles, and is divided into the four districts of Lagonegro, Matera, Melfi, Potenza. The population in 1871 was 500,543. In the N.W. of the territory the Apennines divide into two branches, the one running eastward to Terra di Bari, and the other southward to Calabria. The principal rivers are the Bradano, Basento, Salandrella, Agri, and Sinnò, all flowing into the Gulf of Taranto. The principal productions are maize, wine, linen, hemp, and tobacco; swine, goats, and sheep, are numerous; and the produce of the silkworm forms a considerable branch of industry. The cotton plant thrives

well on low grounds near the sea. The chief towns are Potenza, Melfi, Francavilla, Rionero, and Turai.

**BASILIDES**, one of the most celebrated of the Gnostics, flourished probably about 120 A.D. Extremely little is known of his life. He is said to have been born in Syria and to have studied at Alexandria, and this is probably correct. There is, to some extent, a corresponding uncertainty with regard to the precise doctrines held by him. Of these there are two distinct expositions, the one given chiefly by Irenæus, which has been long before the world, the other contained in the *Philosophumena* of Hippolytus, discovered in 1842. According to Irenæus, the system of Basilides strongly resembled that of Valentinus. The first principle or root of all things, was the supreme God, the unknown and unborn Father. From Him emanated in succession *voûs*, *λόγος*, *φρόνησις*, *σφῆρις*, and *δύναμις*. From the last, according to Irenæus, sprang the powers who created the first heaven; according to Clemens Alex., however, from *δύναμις* sprang *δικαιοσύνη* and *εὐφροσύνη*, and these seven with the Father formed the first Ogdoad, or octave of existence. From them emanated other powers, by whom the second heaven was made, and so on in succession, each system being a more shadowy type or reflex of the original ogdoad. The number of heavens was 365, whence the whole series was called *Abraaxas*, or *Abraaxa*, a name frequently applied to the lower deity, or even, as by Tertullian, to the supreme God. The powers of the lowest heaven, of whom the chief was called the *ἄρχων*, created the earth. This *ἄρχων* is the God of the Jews, and against Him the other powers were arrayed. To alleviate the misfortunes of the earth, the *voûs*, or first emanation, became incarnate and descended upon earth. The *voûs* as incorporeal could not suffer death; accordingly, he changed forms with Simon of Cyrene, and stood by the cross, laughing at his enemies, while Simon suffered in his place. Salvation is spiritual, pertains only to the soul; outer actions are not in themselves good or bad. That Basilides taught this doctrine of moral indifference is not perfectly clear, but Irenæus reports that his disciples acted up to it.

The exposition given by Hippolytus is widely different. According to the account he gives, Basilides started neither with a dualism of God and matter or evil, nor with a theory of emanation. His first principle was God, the unknown, incomprehensible, unspeakable, non-existent one, of whom nothing can be predicated, for no words are adequate to express His essence. This non-existent God, by the exercise of what may be called volition, created the *πνευματικὴ ἰσχύς*, or seed, which contained in itself the germs of all things. In this chaotic mass, which strongly resembles the *δυσκομοσῆ* of Anaxagoras, there is a mixture of elements,—*σύγκλιον ἄρχοντι*,—and at the same time are embedded in it three degrees or kinds of divine sonship, consubstantial with the Deity. The first kind is refined and pure, the second gross, the third requiring purification. As all things naturally tend towards God, the first sonship ascended and sat beside the Father. The second also strove to ascend by means of the Spirit, which is to him as a wing, but he could not rise quite to the Deity, and occupied an inferior position, while the wing or spirit formed the firmament. The third sonship still remained immersed in matter. Then from the world seed there burst forth the great *ἄρχων*, or ruler, who ascended as far as the firmament, and, imagining that there was nothing beyond, glorified himself as the brightest and strongest of all beings. This ruler, who is sometimes called *Abraaxas*, but whose true name is ineffable, produced a son wiser and better than himself, by whose aid he laid the foundations of the world. The seat of their rule is called the Ogdoad, and it extends through all the ethereal region down to the moon's sphere,



where the grosser air begins. This lower dominion is ruled by a second and inferior *ἄρχων*, the God of the Jews, who also had produced a son; and their seat is called the Hebdomad. Meanwhile, the third sonship, which is truly the spiritual element in the elect, is tied to matter, and is in need of deliverance. Freedom is given by the truth, *i.e.*, by a knowledge of the true system of things, and it is given by a series of illuminations. First the mind of the son of the Great Archon is enlightened, and he instructs his father, who learns with fear and repentance that there is a sphere of being higher than his own. The light then passes to the son of the Archon of the Hebdomad, who likewise instructs his father. Finally, the mind of Jesus is illuminated, and he instructs those of mankind who are able to receive the truth. There are thus three great stages in the world's religious history, each being an advance on its predecessor. These periods are the Ante-Jewish, the Jewish, and the Christian. All the souls capable of receiving the light ascend upwards, while their bodies return to the primeval chaos; the minds of all others are shrouded in eternal night, the darkness of ignorance. For the relation of Basilides to other Gnostics, and for the interpretation of his intensely symbolic expressions, see Gnosticism.

The earlier accounts of Basilides, such as those of Neander, Baur (in the *Christliche Gnosis*), and Matter, were based for the most part on Irenæus. The discovery of the *Philosophumenus* threw unexpected light on the subject, and the later expositions generally follow Hippolytus as the exponent of the original system of Basilides. Hilgenfeld still retains the older view. Full information is to be found in Baur, *Kirchengeschichte*, I.; Lipsius, *Gnosticismus*; Uhlhorn, *Das Basilideanische System*; Mansel, *Gnostic Heresies*.

**BASILISK**,—*βασιλίσκος* of the Greeks, and *Tsepha* (cockatrice) of the Hebrews,—a name applied by the ancients to a horrid monster of their own imagination, to which they attributed the most malignant powers and an equally fiendish appearance. The term is now applied, owing to a certain fanciful resemblance, to a genus of Lizards belonging to the family *Iguanidae*, the species of which are characterized by the presence of a membranous bag on the crown of the head, which they can distend or contract at will, and of a fin-like ridge along the back and part of the tail. Both appendages are admirably adapted for aiding the basilisk in swimming, while they do not impede its movements on land,—its mode of life being partly aquatic, partly arboreal. The Mitred Basilisk occurs in Guiana, the Hooded Basilisk in Amboyna.

**BASINGSTOKE**, a market and borough town in the county of Hants, 45 miles from London. It occupies a pleasant situation, and has a good trade in corn and malt, which has been greatly facilitated by the canal which joins the rivers Wey and Thames. The parish church, St Michael's, is a spacious and handsome structure, dating from the reign of Henry VIII. In the neighbourhood is Basing House, remarkable for its defence by the marquis of Winchester against the Parliamentary forces in 1645. Population in 1871, 5574.



Arms of Basingstoke.

**BASKERVILLE, JOHN**, a celebrated printer, and the introducer of many improvements in type-founding, was born at Wolverley in Worcestershire in 1706, and died in 1775. About the age of twenty he became a writing-master at Birmingham, and he seems to have had a great talent for calligraphy and carving in stone. While at Birmingham his attention was attracted to the business of japanning, which he took up with great zeal. He made some important improvements in the process, and gained a considerable fortune. About the year 1750 he began to make experiments in type-founding, and soon succeeded in

producing types much superior in distinctness and elegance to any that had hitherto been employed. He then set up a printing-house, and published his first work, a *Virgil* in royal quarto. *Horace*, *Terence*, *Catullus*, and others were also printed by him. These books are admirable specimens of typography; and Baskerville is deservedly ranked among the foremost of those who have advanced the art of printing. He did not print many works, as the sale did not meet his expectations; after 1765, indeed, he seems to have put forth very little. Specimens from the Baskerville press are not easily had, and are of considerable value.

**BASKET**, a utensil made of twigs, rushes, or strips of wood, as well as of a variety of other materials, interwoven together, and used for holding or carrying any commodity. Modern ingenuity has applied many substances before unthought of to the construction of baskets, such as iron and even glass. But wicker-work being the oldest as well as the most universal invention, it alone will be treated of in the present article. The process of interweaving twigs, seeds, or leaves, is practised among the rudest nations of the world; and as it is one of the most universal of arts, so also does it rank among the most ancient industries, being probably the origin of all the textile arts of the world. A bundle of rushes spread out may be compared to the warp of a web, and the application of others across it to the woof, also an early discovery; for basket-work is literally a web of the coarsest materials. The ancient Britons appear to have excelled in the art of basket-making, and their baskets were highly prized in Rome as we learn from Martial (xiv. 99):—

“Barbara de pletis venit bascula Britannis;  
Sed me jam mavult dicere Roma suam.”

Among many uncivilized tribes at the present day baskets of a superior order are made and applied to various useful purposes. The North American Indians prepare strong water-tight “Wattape” baskets from the roots of a species of *Abies*, and these they frequently adorn with very pretty patterns made from the dyed quills of their native porcupine, *Erethizon dorsatum*. The Indians of South America weave baskets equally useful from the fronds of the Carnahuba and other palms. The Kaffres and Hottentots of South Africa are similarly skilful in using the Ilaa reed and the roots of plants; while the tribes of central Africa and the Abyssinians display great adroitness in the art of basket-weaving.

Basket-making, however, has by no means been confined to the fabrication of those simple and useful utensils from which its name is derived. Of old, the shields of soldiers were fashioned of wicker-work, either plain or covered with hides; and the like has been witnessed among modern savages. In Britain the shields of the ancient warriors, and also their huts, even up to the so-called palaces of the Saxon monarchs, were made of wicker-work; and their boats of the same material, covered with the skins of animals, attracted the notice of the Romans. Herodotus mentions boats of this kind on the Tigris and Euphrates, but with this difference, that the former seem to have been of the ordinary figure of a boat, whereas the latter were round and were covered with bitumen. Boats of this shape, about 71 feet in diameter, are used at the present day on these rivers; and boats of analogous construction are employed in crossing the rivers of India which have not a rapid current. Nothing can be more expeditious or more simple than the fabrication and materials of these vessels, if they merit that name. One may be made by six men in as many hours,—only two substances, hides and bamboo, almost always accessible, being used. Window screens, perambulators, chairs, &c., are now largely made of basket-

work, and the light pony basket carriages in general use are the representatives of the Continental Holstein waggon of the early part of the century, which was a two-horse basket carriage of considerable size. In Berlin and Kiel there now exist large factories of "Korb Möbel," devoted to the manufacture of basket-work chairs, tables, stands, frames, screens, &c., and the use of this description of furniture is very general in Continental houses.

The materials which are actually employed in the construction of basket-work are numerous and varied, and to the principal of these allusion will be made below. As it is, however, from various species of willow that the largest supply of basket-making materials is produced, we shall first confine our attention to this source. Willows for basket-work are extensively grown in Holland, Belgium, France, and Germany, whence large quantities are exported to Great Britain and even to the United States. The willows of France are highly esteemed by basket-makers as firm, clean rods; and the Dutch produce are lowest in value, being soft and pithy. No Continental rods equal those of English growth for their tough and leathery texture, and the finest of all basket-making willows are now cultivated in large quantities in the valleys of the Thames and the Trent. It was only in the early part of this century that any considerable attention was given in Britain to the cultivation of willows suitable for basket-making; and the industry was first stimulated by premiums offered by the Society for the Encouragement of Arts and Manufactures. Mr Phillips of Ely was one of the most successful early cultivators of willows, and to his exertions we owe the introduction of a valuable willow, the Brown Norfolk, *Salix triandra*. Mr Phillips's observations and experiments largely contributed to place the willow cultivation on a satisfactory commercial basis, and a similar service was rendered in Scotland by Mr Sheriffs; but the systematic maintenance of willow holts has not been continued in Scotland. One of the most successful growers of willows at the present day is Mr William Scaling of Basford, Notts, who cultivates a salicium of about 100 acres in extent. Mr Scaling has the advantage of being a practical basket-maker, and the facts which follow regarding the growth and varieties of basket-willows are chiefly gleaned from his pamphlets on willow cultivation.

The genus *Salix*, to which all willows and osiers belong, is extremely complex in its botanical characters, and the species and varieties, as systematically arranged, are very numerous. Those cultivated for basket-making Mr Scaling divides into four classes. The first class, which alone get the name of willows among basket-makers, includes the rods of six or seven different species, all of which Mr Scaling classes with *Salix fragilis*. The "willows" yield inferior basket-rods, having a tendency to throw out side-shoots which makes the rods "rough." The second class comprises the osiers, including about forty varieties used by basket-makers all grouped around the osier, *Salix viminalis*, and these form the staple of basket-making materials. In the third class, which are known in the trade as "Spaniards" or Spanish willows, are included about thirty varieties which are classed under *Salix amygdalina*. The "Spaniards" comprise some of the most useful basket-willows, the wood being more dense and elastic than is the case with osiers. The fourth class comprises the bitter willows, of which *Salix purpurea* is taken as the type, and the rods they yield are known as "whipcord," "swallow tail," or "one-yard." These are the finest of all willows for basket-making, and owing to their bitterness they are not attacked by rabbits and hares, which frequently do much damage to all other varieties.

It was long supposed that willows flourish nowhere but with abundance of water. Undoubtedly the osier class

thrive well with a considerable degree of humidity, but a dry well-drained soil is best suited for all hard-wooded varieties. For the laying out of a willow holt Mr Scaling recommends that the land should be well drained, cleared and tilled to a depth of about one foot. Willows are propagated solely from cuttings, which retain their vitality long, and strike with great facility. The cuttings are made about 9 inches long, and two or three may be obtained from a single rod. They should be planted in rows from 16 to 18 inches apart, the plants in each row being placed at intervals of from 8 to 12 inches according to the size of the willow under cultivation; and the entire length of the cutting should be pushed into the ground. The planting may be done at any time from late autumn to early spring during the period of plant rest, when the ground is free from frost. At the end of each year the shoots are to be cut down close to the ground, manure is laid on between the rows and ploughed in, and the soil should be kept as open and free from weeds as arable land. The produce of the first year will, as a rule, be of little value; nevertheless, in Mr Scaling's opinion, it is of consequence that the rods should be cut down. The second year's crop should yield a good return; in the third year the plants are at their best, and for the ten following years they should exhibit undiminished productiveness, after which they gradually decline in strength. The entire cost of a salicium per acre Mr Scaling estimates, for the first year, at £33, 12s., and the return at £8, 12s. The outlay for the next two years he gives as £7, 5s. and £6, 15s., but the crops of these years should yield £17 and £22, just covering the cost of planting, which is the ordinary calculation of growers.

The rods intended for basket-making are either taken entire, cut from the root, split asunder, or stripped of their bark, according to the work to be produced; but in all cases they are previously soaked in water, and indeed sometimes boiled. The stripping is performed by drawing the willows through a bifurcated iron implement called a brake, which removes the bark, and the willows are then cleaned, as far as necessary, by manual operation with a knife. When they are boiled previous to peeling a very nice light brown colour is developed in the wood by the action of the tannin contained in the bark, and rods thus prepared are much more durable than those peeled white. Next they are exposed to the sun and air, and afterwards placed in a dry situation. But it is not the less necessary to preserve willows with their bark in the same manner; for nothing can be more injurious than the humidity inherent in the plant; and previous to use they must be soaked some days in water also. The barked or white osier is then divided into bundles or faggots according to size; the larger being reserved to form the strong work in the skeleton of the basket, and the smaller for weaving the bottom and sides. Should the latter be applied to ordinary work, they are taken whole; but for implements of slight and finer texture, each osier is divided into splits and skains of different degrees of size. Splits are osiers cleft into four parts, by means of an implement employed for that purpose called a cleaver, which is a wedge-shaped tool inserted at the point or top end of the rod and run down through its entire length. These are next drawn through an implement resembling the common spoke-shave, keeping the grain of the split next the iron or stock of the shave, while the pith is presented to the steel edge of the instrument, which is set in an oblique direction to the wood; and in order to bring the split into a shape still more regular, it is passed through another implement called an upright, consisting of a flat piece of steel, each end of which is fashioned into a cutting edge, like that of an ordinary chisel. The flat is bent round, so that the two edges approach each other at a greater or less interval by

means of regulating screws, and the whole is fixed into a handle. By passing the splits between the two edges they are reduced to skains, the thickness of which is determined by the interval between the edges of the tool.

The implements required by a basket-maker are few and simple. They consist, besides the preceding, of knives, bodkins, leads for keeping the work steady while in process; and where the willows are worked as rods a heavy piece of iron called a beater is employed to beat them close as they are woven in. On the Continent, where fancy baskets are made, blocks are required on which the webs of wicker-work are set to particular shapes.

An ordinary basket is made by preparing the requisite number of osiers, and preserving their length considerably greater than that of the finished work. They are ranged in pairs on the floor parallel to each other, at small intervals, in the direction of the longer diameter of the basket; and this may be called the woof,—for, as we have said, basket-work is literally a web. These parallel rods are then crossed at right angles by two of the largest osiers, with the thick ends towards the workman, who places his foot upon them; and being each woven alternately over and under the parallel pieces first laid down, they are by that means confined in their places. The whole now forms what is technically called the alath, which is the foundation of the basket. Next the long end of one of the two rods is taken and woven under and over the pairs of short ends all round the bottom, until the whole is woven in. The same is done with the other rod, and then additional long osiers are also woven in, until the bottom be of sufficient size, and the woof be occupied by them. Thus the bottom or foundation on which the superstructure is to be raised is finished; and this latter part is accomplished by sharpening the large ends of as many long and stout osiers as may be necessary to form the ribs or skeleton. These are forced or plaited, "scalloped," between the rods of the bottom from the edge towards the centre, and are turned up, "upset," in the direction of the sides; then other rods are woven in and out between each of them, until the basket is raised to the intended height, or, more correctly speaking, the depth it is to receive. The edge or brim is finished by turning down the perpendicular ends of the ribs, now protruding and standing up, over each other, whereby the whole is firmly and compactly united. A handle is adapted to the work by forcing one or more rods called bale sticks, sharpened at the end and cut to the requisite length, down the weaving of the sides, close together; and they are pinned fast, or tied by means of the rods used in twisting over the bale rods, about two inches from the brim, in order that the handle, when completed, may be retained in its proper position. The osiers are then either bound or plaited in such fashion as pleases the taste of the artist. This is the most simple kind of basket, from which others differ only in finer materials and nicer execution; but in these there is considerable scope for taste and fancy, and implements are produced of extreme neatness and ingenuity in construction. The skains are frequently smoked and dyed either of dull or brilliant colours, and by intermixing them judiciously, as also by varnishing over the colour, a very good effect is produced.

From the simplicity of this manufacture, a great many individuals, independent of professed basket-makers, are occupied in it; and it affords suitable employment to the blind in the several asylums and workhouses established for their reception in this and other countries.

In addition to willows, a large variety of other materials is employed in the fabrication of wicker-work. Among the most important of these are splits of various species of bamboo, with which the Japanese and Chinese manufacture baskets of unequalled beauty and finish. The bamboo wicker-work with which the Japanese sometimes encase their delicate egg-shell porcelain is a marvellous example of manipulation, and they and the Chinese excel in the application of bamboo wicker-work to furniture. The "canes" or rattans of commerce, stems of species of *Calamus* and *Damonocrops* are scarcely less important as a source of basket materials. In India "Cajan" baskets are extensively made from the fronds of the Palmyra palm, *Borassus flabelliformis*; and this manufacture has in recent years been established in the Black Forest of Germany, where it is now an important and characteristic staple. Among the other materials may be enumerated the odorous roots of the Khus-Khus grass, *Anatherum muricatum*, and the leaves of various species of screw pine, used in India and

the East generally. The fronds of the palm of the Seychelles Islands, *Lodicea seychellarum*, are used for very delicate basket-work in those islands. Strips of the New Zealand flax plant, *Phormium tenax*, are made into baskets in New Zealand. Esparto fibre is used in Spain and Algeria for rude fruit baskets. Various species of *Maranta* yield basket materials in the West Indies and South America; and the Tirite, a species of *Calathea*, is also similarly employed in Trinidad. Baskets are also frequently made from straw, from various sedges (*Cyperus*), and from shavings and splints of many kinds of wood.

In the basket trade special centres are recognized as the headquarters of various styles of work met in the market. Thus Birmingham is recognized as the source of wicker perambulators; in Southport boiled willows are used, and the brown baskets for gardening and market purposes are produced, and at Castle Donnington, in Derbyshire, the flat skain work seen in fishing-baskets, &c., is chiefly made. In the department of Aisne, France, the *berceauettes* or bassinets is very largely manufactured, and in Verdun much basket-work is specially prepared to suit the English market, in which the French manufacturers are able freely to compete. The Black Forest and other German manufacturers produce enormous quantities of light elegant baskets, which are largely exported. In Austria lacquered and varnished baskets are made in imitation of gold, silver, and steel, and Viennese card baskets, &c., are frequently ornamented with plaques of painted porcelain inserted in the centre.

BASNAGE, JACQUES, pastor of the Walloon Church at the Hague, was born at Rouen in Normandy on the 8th of August 1653. He was the son of Henri Basnage, one of the ablest advocates in the parliament of Normandy. At the age of seventeen, having acquired a good knowledge of the Greek and Latin authors, as well as of the English, Spanish, and Italian languages, he went to Geneva, where he began his theological studies under Mestrezat, Turretin, and Tronchin; he completed them at Sedan, under the professors Jurieu and Leblanc de Beaulieu. He then returned to Rouen, where he was received as pastor in September 1676; and in this capacity he remained till the year 1685, when, the exercise of the Protestant religion being suppressed at Rouen, he obtained leave of the king to retire to Holland. He settled at Rotterdam, and continued a minister pensionary there till 1691, when he was chosen pastor of the Walloon Church of that city. In 1709, the pensionary Heinius secured his election as one of the pastors of the Walloon Church at the Hague, intending to employ him not only in religious but also in civil affairs. Accordingly he was engaged in a secret negotiation with Marshal d'Uxelles, plenipotentiary of France at the congress of Utrecht,—a service which he executed with so much success, that he was afterwards intrusted with several important commissions, all of which he discharged with such ability and address that Voltaire said of him that he was fitter to be a minister of state than the minister of a parish. The Abbé Dubois, who represented France at the Hague in 1716, in negotiating a defensive alliance between France, England, and the States-General, received instructions to consult with Basnage; they accordingly acted in concert, and the alliance was concluded in January 1717. His numerous published works, which are mostly in French, include—*The History of the Religion of the Reformed Churches*; *Jewish Antiquities*, *The History of the Old and New Testament*; *Dissertation on Duels*, &c. He died on the 22d September 1723.

BASQUE PROVINCES (*Provincias Vascongadas*). The three Spanish provinces known by this name, which are distinguished from all the other divisions of Spain by

the character, language, and manners of the inhabitants, and by the enjoyment of political privileges which make the form of their government nearly republican, are Biscay (Viscaya), Guipuzcoa, and Alava. The territory occupied by them is in the form of a triangle, bounded on the N. by the Bay of Biscay, S. by Soria, E. by Navarra and part of France, and W. by Santander and Burgos. It comprises an area of 2958 square miles; population in 1867, 414,146. These three provinces are more particularly described under their respective heads. The French Basque provinces now form the arrondissements of Bayonne and Mauleon. The Basque language, which is also prevalent in Navarra, is still spoken by about 600,000 Spaniards and French. Its native name is *Eskera*. It cannot be classed with any Indo-European or Semitic tongue, and appears to be of earlier origin, presenting some grammatical analogies with Mongol, North American, and certain East African languages. The forms of ordinary grammar are therefore imperfectly applicable to it. The substantive has no distinction of gender; it is made to express, by means of an extensive system of affixes, all the ordinary declensional and conjugal relations, and many which in other languages can only be expressed by periphrasis. The termination of a word may thus express together mood, tense, person, number, the case and number of the object, and also the sex, rank, and number of the individuals addressed, besides other relations. Foreign words are thus easily assimilated, but with modifications to suit the Basque ear, the latter varying according to local dialect. Diminutives and other general affixes increase the delicacy of expression, and a wide range of speech is early acquired by the natives. Compound words are readily formed by mere juxtaposition, or by elision of syllables, with peculiar modifications for euphony. The article has two forms—a for the singular, *ak* for the plural—affixed to the substantive. There appears to be no genuine Basque word beginning with *r*. In the usual structure of the sentences the noun, with the article affixed, occupies the first place; it is followed by the adjective, then the adverb, next the verb, and lastly the object with its prepositional affix. No written Basque is known of earlier date than the 15th century, and little genuine literature exists; the orthography is therefore arbitrary, and the earliest writings are difficult to interpret. All that has yet been noticed regarding manners, customs, institutions, and legends may be paralleled by those of other Pyrenean peoples, or traced to foreign influences. But, through their moral qualities, physical situation, and historical circumstances the Basques have built up and preserved a body of customs and institutions highly original in the mass. Each province is governed by a parliament composed of representatives selected partly by election, partly by lot, among the householders of each country pariah or town. A deputation, named by the parliament, ensures the strict observance of the special laws and customs of the province, and negotiates with the representative of the Spanish Crown. Delegates from the three parliaments meet annually to consider the common interests of the provinces; they employ a seal representing three interlaced hands, with the motto *Irraobot*, "the three are one;" but no written federal pact exists. Much speculation regarding the origin of the Basques has been indulged in without sufficient special knowledge. The belief that they originally occupied great part of Spain and Southern France, founded on the apparently Basque character of certain local names, is very generally accepted. The best introduction to all Basque questions is Bladé's *Études sur l'origine des Basques*, which sums up the literature of the subject to 1870. *Éléments de Grammaire Basque*, by L. Gêze, Bayonne, 1873, is a

good practical grammar and vocabulary with exercises; the *Dictionnaire Basque Français* of Van Eyme is a particularly instructive lexicon.

**BASS ROCK**, an islet of greenstone and trap tuff, about a mile in circumference, on the coast of East Lothian near the entrance of the Firth of Forth, in 56° 4' N. lat., and 2° 37' W. long. Purchased from the Lauder family by Charles II. in 1671, it was afterwards converted into a place of confinement for state prisoners, and during the religious troubles of Scotland numbered among its captives Peden, Blackadder, and other Covenanting leaders. At the Revolution a party of King James's adherents got possession of the island, and held out after the whole of Great Britain had submitted. Dismantled of its fortifications in 1701, the Bass Rock again became private property, and is now farmed for the sake of the sea-fowls that resort thither during the breeding season. See *The Bass Rock, its Civic and Ecclesiastical History, &c.* (Edin. 1848), by M'Crle, Hugh Miller, Anderson, Fleming, and Balfour.

**BASS'S STRAITS**, the channel which separates Tasmania from Victoria. It is about 180 miles in length from E. to W., and about 140 from N. to S. The navigation of the strait is rendered dangerous in some parts by groups of barren islands and coral reefs scattered through it. It bears the name of Bass, the surgeon of a man-of-war, who was the first to discover, in 1798, indications of a channel between Tasmania and the neighbouring island-continent.

**BASSÁHIE**, a Rájput hill state in Hindustán, under the political superintendence of the Lieutenant-Governor of the Panjáb, situated between 30° 56' and 32° 8' N. lat., and 77° 34' and 78° 52' E. long. It is bounded on the N. by the Spiti valley, on the E. by Chinese Tartary, on the S. by the district of Garhwál, and on the W. by several small hill states. The aspect of the country is very hilly, and it is nowhere less than 4000 feet above sea-level. Principal rivers, the Pabur and Satiéj. Estimated population, 90,000; chief towns and villages, Rampur, Chini, Songlá, and Morang. Agricultural products—wheat, opium, and Indian corn. Manufactures—blankets, shawls, and woollen cloths. Estimated gross revenue of the state, £5000 a year. Tribute paid by the chief to the British Government, £394, 10s. per annum. Estimated military force of the state, 100 men.

**BASSANO**, a city of Italy in the province of Vicenza. It stands on the river Brenta, over which there is a bridge 180 feet in length, built by Palladio. It is surrounded with walls, and has six gates, one of which, also by Palladio, is very much admired. In the centre of the town is the tower of Eszelino, which now contains a library and armoury. The town contains thirty-five churches (some of them with fine paintings), several religious houses, and other public edifices. It has extensive silk-mills, besides manufactures of cloth, paper, straw hats, copper wares, &c.; and the printing establishment of S. Remondini is one of the most extensive in Italy. In 1796 Bonaparte defeated the Austrian general Wurmser in the neighbourhood, and various skirmishes took place between the two forces in 1801, 1805, 1813. Maret derived from the town his title of duke of Bassano. Population, 13,254.

**BASSANO, GIACOMO DA FONTE**, a Venetian painter, born in 1510 at Bassano. He was educated by his father, who was himself an artist, and then completed his studies at Venice. On the death of his father he returned to Bassano, and settled there. His subjects were generally peasants and villagers, cattle, and landscapes, with some portraits and historical designs. His figures are well designed, and his animals and landscapes have an agreeable air of simple nature. His compositions, though they have not much eloquence or grandeur, have abundance of force and

truth; the local colours are well observed, the carnations are fresh and brilliant, and his chiaroscuro and perspective are unexceptionable. He is said to have finished a great number of pictures; but his genuine works are somewhat rare and valuable,—many of those which are called originals being copies either by the sons of Bassano, or by others. He died in 1592, aged eighty-two. Bassano's style varied considerably during his lifetime. He naturally was at first a copier of his father, but his productions in this style are not of great value. He was then strongly attracted by the lightness and beautiful colouring of Titian, and finally adopted the style which is recognized as his own. Although he painted few great pictures, and preferred humble subjects, yet his altar-piece of the Nativity at Bassano is estimated highly by the best judges, and in Lanzi's opinion is the finest work of its class in existence.

**BASSE-TERRE**, the capital of St Christopher's, one of the British West India Islands. Population, 8500. See **SAINTE CHRISTOPHER'S**.

**BASSE-TERRE**, formerly the capital of Guadeloupe, one of the French West India Islands. Population, 9480. See **GUADELOUPE**.

**BASSEIN**, a British district on the eastern coast of the Bay of Bengal, under the jurisdiction of the Chief Commissioner of Burmah, lies between 15° and 18° N. lat., and 94° and 96° E. long. It is bounded on the N. by the districts of Kyoank Phoo and Myanoung, on the E. by the district of Rangoon, and on the S. and W. by the Bay of Bengal. A mountain range called the Anouk-phet Toungmyeng stretches through the district from north to south along the coast. The principal river of the district is the Irawadi, which debouches on the sea at its eastern extremity through a delta intersected with salt water creeks, among which the Pymalaw, Deay Pyoo, Thekadoung, and Nga Woon or Bassein River rank as important arms of the sea. Shagay-gyee and Engyay-gyee are the only two lakes in the district. The delta of the Irawadi forms, wherever cultivable, a vast sheet of rice, with cotton, sesamum, and tobacco as subsidiary crops. Bassein district has an area of 8954 square miles, of which only 351 are cultivated. In 1871-72 the population amounted to 316,883, residing in 65,722 houses, and inhabiting 1554 villages, of whom 213,816, or 67 per cent. were Buddhists, 78,684 aborigines, 20,810 Christians, 2119 Mahometans, 723 Hindus, and 12 Paras. Density of population, 34·03 per square mile. The population consisted of 31,369 agriculturists, and 285,464 non-agriculturists. Total revenue in 1870-71, £118,672, of which £36,676, or 30 per cent., was derived from land. Principal towns and villages in Bassein—(1), Bassein, population 19,577; (2), Laymyethna, 5325; (3), Pantanaw, 5876; (4), Yaygyee, 4893; (5), Nga-thainkhyoung, 3178; (6), Kaungyeadaing, 1500; (7), Shweloung, 1317; (8), Myoung-mya, 1477; (9), Nga-poo-tau, 981; and (10), Kyoon-pyaw, 1655.

**BASSEIN**, the principal place of the district of the same name, situated in 16° 45' N. lat., and 94° 50' E. long., on the eastern bank of the Bassein River, one of the main arteries by which the waters of the Irawadi discharge themselves into the sea. It forms an important seat of the rice trade, and has great capabilities both from a mercantile and a military point of view, as it commands the great outlet of the Irawadi. It fell before the British arms, in May 1852, during the second Burmese war. Since then the town population has rapidly increased, and numbered 19,577 in 1871, chiefly fisher-men, craftmen, traders, and persons connected with the rice commerce.

**BASSELIN**, OLIVIER, an old French poet or writer of verses, was born in the Val-de-Vire in Normandy about the middle of the 14th century, and died about 1418 or 1419. He was by occupation a fuller, and had a mill on

the small river Vire. His songs were sprightly and joyous, and became famous. The modern Vaudevilles take their origin and name from them, and were originally called Vaux-de-Vire, *vaux* being the plural of *val*; though, according to Ménage, the word is derived from a small town Vaux near the Vire. Basselin's poems were collected and published in the 16th century by Jean le Houx, and have since been re-edited by M. Asselin in 1811, and by M. Travers in 1833. The latest edition, that by P. L. Jacob, 1858, contains some other poems in addition to those of Basselin.

**BASSI**, LAURA MARIA CATERINA, an Italian lady, eminently distinguished for her learning, was born at Bologna in 1711. On account of her extraordinary attainments she received a doctor's degree, and was appointed professor in the philosophical college, where she delivered public lectures on experimental philosophy till the time of her death. She was elected member of many literary societies, and carried on an extensive correspondence with the most eminent European men of letters. She was well acquainted with classical literature, as well as with that of France and Italy. In 1738 she married Giuseppe Verrati, a physician, and left several children. She died in 1778.

**BASSIANUS**, JOANNES, a distinguished professor in the law school of Bologna, the pupil of Bulgarus and the master of Azo. Little is known of his origin, but he is said by Carolus de Tocco to have been a native of Cremona. The most important of his writings which have been preserved is his *Summary on the Authentica*, which Sevigny regards as one of the most precious works of the school of the Gloss-writers. Joannes, as he is generally termed, was remarkable for his talent in inventing ingenious forms for explaining his ideas with greater precision, and perhaps his most celebrated work is his "Law-Tree," which he entitled *Arbor Arborum*, and which has been the subject of numerous commentaries. The work represents a tree, upon the branches of which the various kinds of actions are arranged after the manner of fruit. The civil actions, or *actiones stricti juris*, being forty-eight in number, are arranged on one side, whilst the equitable or *prætorian* actions, in number one hundred and twenty-one, are arranged on the other side. A further scientific division of actions is made by him under twelve heads, and by an ingenious system of notation the student is enabled to class at once each of the civil or prætorian actions, as the case may be, under its proper head in the scientific division. By the side of the tree a few glosses were added by Joannes to explain and justify his classification. His *Lectures on the Pandects* and the *Codes*, which were collected by his pupil Nicolaus Furiosus, have unfortunately perished.

**BASSOON**, a musical wind instrument of the reed order, made of wood, and played through a bent mouth-piece of metal. It has a compass of about three octaves, from B flat below the bass staff to C in the treble staff, and may thus be regarded as the bass instrument corresponding to the oboe and clarinet. See **MUSICAL INSTRUMENTS**.

**BASSO-RILIEVO**. See **ALTO RILIEVO** and **RELIEF**.

**BASTAR**, a feudatory state in the Central Provinces of British India, situated between 20° 10' and 17° 40' N. lat., and 80° 30' and 82° 15' E. long., bounded on the N. by the Kanker zamindari and the Raipur district; on the E. by the Bendrá Nawágarh zamindari and Raipur, Jaipur state, and Sabari River; on the S. by the Sironchá district; and on the W. by the Indravati River and the Aheri zamindari. Extreme length of the state, 170 miles; extreme breadth, 120 miles; area, estimated at 13,000 square miles. Total population, 78,856, consisting of—Hindus, 29,060; Mussalmans, 1704; aboriginal tribes of Gond origin, 48,092. Among the latter, the *Máris* are a

timid, quiet, docile race, and although addicted to drinking are not quarrelsome. They inhabit the densest jungles, and are very shy, avoiding contact with strangers, and flying to the hills on the least alarm; but they bear a good character for honesty and truthfulness. They are very scantily dressed, wear a variety of trinkets, with a knife, hatchet, spear, bow and arrow, the only weapons they use. Their hair is generally shaved, excepting a topknot; and when not shaved it gets into a matted, tangled mass, gathered into a knot behind or on the crown. The Máriás, a class of the Máriás, live in still denser jungles, and have little or no communication with the outside world. The Máriás and the Jhuríás are supposed to be a subdivision of the true Gond family. All the aboriginal tribes of Bastár worship the deities of the Hindu pantheon along with their own national goddess Dantewari.

The eastern part of Bastár is a flat elevated plateau, from 1800 to 2000 feet above the level of the sea, the centre and north-west portions are very mountainous, and the southern parts are a mixture of hill and plain. On the plateau there are but few hills; the streams run slowly, and the country is a mixture of plain and undulating ground covered by dense *sal* forests. Principal mountains of the district—(1), A lofty range which separates it from the Sironohá district; (2), a range of equal height called the Belá Dillá lying in the centre of the district; (3), a range running north and south near Náráyanpur; (4), Tángri Dongri range, running east and west; (5), Tulá Dongri, bordering on the Sabari River and the Jaiपुर state. There is also a small range running from the River Indravati to the Godávári. The Indravati, the Sabari, and the Táí or Táípur, are the chief rivers of the district; all of them affluents of the Godávári. The soil throughout the greater portion of Bastár consists of light clay, with an admixture of sand, suited for raising rice and wet crops. Rice, sugar, and a little wheat and gram are the agricultural products of Bastár. In the jungles the Máriás and Máriá rear *kosá* (*Pennisetum italicum*) and other inferior grains. The aboriginal races generally follow the migratory system of tillage, clearing the jungle on selected patches, and after taking crops for two or three years abandoning them for new ground. Máriá do not use the plough; nor do they possess buffaloes, bullocks, or cows; their only agricultural implement is a long-handled iron hoe. Lac, resin, wax, galls, horns, rice, a red dye called *sandri*, wild arrow-root, molasses, teakwood, and tassar-silk cocoons, are the chief staples of export. The imports, which considerably exceed the exports, consist of salt, piece-goods, brass utensils, cocoa-nuts, pepper, spices, opium, turmeric, cotton, wheat, &c. Iron-ore is found towards the eastern portion of the state, but is not much worked; gold is also found in certain places. Bastár is divided into two portions—that held by the Rájá or chief himself, and that possessed by feudatory chiefs under him. There is not a single made road within the principality. The climate of Bastár is unhealthy—fever, smallpox, dysentery, diarrhoea, and rheumatism being the prevailing diseases. Jagdalpur, Bijápur, Maddar, and Bhupápatnam are the only places of any note in the dependency, the first-named being the residence of the Rájá and the chief people of the state. The grossest ignorance and superstition prevail, and the people live in constant fear of being bewitched or ruined by malicious magicians. The family of the Rájá of Bastár claims to be of the purest Rájput blood, and traces its origin to Warangal in the Dakhín, about the commencement of the 14th century. The revenue of Bastár is supposed to be £3610; the tribute paid by the chief to the British Government is £305, 12s.

**BASTARD** is a person born out of lawful wedlock, i.e., whose parents have not been married previous to his birth. The rules by which legitimacy is determined vary chiefly as to the effect to be assigned to the subsequent marriage of the bastard's parents. The law of Scotland, and of most Continental countries, following the rules of the civil and canon law, legitimizes the bastard whose parents afterwards marry. The same principle was at one time advocated by the clergy in England, but summarily rejected by the famous statute of Merton (20 Hen. III. c. 9). The English law, however, takes no account of the interval between the marriage and the birth; provided the birth happens after the marriage, the offspring is legitimate. The presumption of law is in favour of the legitimacy of the child of a married woman, and at one time it was so strong that Lord Coke held that "if the husband be within the four seas, i.e., within the jurisdiction of the king of

England, and the wife hath issue, no proof shall be admitted to prove the child a bastard unless the husband hath an apparent impossibility of procreation." It is now settled, however, that the presumption of legitimacy may be rebutted by evidence showing non-access on the part of the husband, or any other circumstance showing that the husband could not in the course of nature have been the father of his wife's child. If the husband had access, or the access be not clearly negatived, and others at the same time were carrying on a criminal intercourse with the wife, a child born under such circumstances is legitimate. If the husband had access intercourse must be presumed, unless there is irresistible evidence to the contrary. Neither husband nor wife will be permitted to prove the non-access directly or indirectly. Children born after a divorce *a mensa et thoro* will be presumed to be bastards unless access be proved. A child born so long after the death of a husband that he could not in the ordinary course of nature have been its father is illegitimate. The period of gestation is presumed to be about nine calendar months; and if there were any circumstances from which an unusually long or short period of gestation could be inferred, special medical testimony would be required. A marriage between persons within the prohibited degrees of affinity was before 1835 not void, but only voidable, and the ecclesiastical courts were restrained from bastardizing the issue after the death of either of the parents. Lord Lyndhurst's Act declared all such existing marriages valid, but all future marriages between persons within the prohibited degrees of consanguinity or affinity were made null and void, and the issue illegitimate. (See MARRIAGE.) By 21 and 22 Vict. c. 93, application may be made to the Court of Divorce and Matrimonial Causes (in Scotland to the Court of Session by action of declarator) for a declaration of legitimacy and of the validity of a marriage.

The law relating to the maintenance of bastard children is governed by a considerable number of statutes passed during the present reign, the Acts of 1872 and 1873 being the last. The mother of a bastard may summon the putative father to Petty Sessions within twelve months of the birth (or at any later time if he is proved to have contributed to the child's support within twelve months after the birth), and the justices, after hearing evidence on both sides, may, if the mother's evidence be corroborated in some material particular, adjudge the man to be the putative father of the child, and order him to pay a sum not exceeding five shillings a week for its maintenance, together with a sum for expenses incidental to the birth. No such order is to be valid after the child is dead or reaches the age of thirteen, but the justices may in the order direct the payments to be continued until the child is sixteen years of age. The putative father may appeal to Quarter Sessions. Should the child afterwards become chargeable to the parish, the sum due by the father may be received by the parish officer. When a bastard child, whose mother has not obtained an order, becomes chargeable to the parish, the guardians may proceed against the putative father for a contribution. The mother of an illegitimate child is entitled to its custody in preference to the father.

The rights of a bastard are only such as he can acquire; for civilly he can inherit nothing, being looked upon as the son of nobody, and sometimes called *filius nullius*, sometimes *filius populi*. This, however, does not hold as to moral purposes, e.g., he cannot marry his mother or bastard sister. Yet he may gain a surname by reputation though he has none by inheritance, and may even be made legitimate and capable of inheriting by the transcendent power of an Act of Parliament. All other children have their primary settlement in their father's parish; but a bastard has his in the parish where he was born, unless

such birth has been procured by fraud, or has happened under an order of removal, in a state of vagrancy, in the house of correction, or under certificate; for in law he has no father. The incapacities attaching to a bastard consist principally in this, that he cannot be heir to any one; for being *sullius filius*, he is therefore of kin to nobody, and has no ancestor from whom an inheritable blood can be derived. Therefore, if there be no other claimant upon an inheritance than such illegitimate child, it escheats to the lord. And as bastards cannot be heirs themselves, so neither can they have any heirs but those of their own bodies; for as all collateral kindred consists in being derived from the same common ancestor, and as a bastard has no legal ancestor, he can have no collateral kindred, and consequently no legal heirs, except such as claim by a lineal descent from himself. And hence, if a bastard purchase land, and die seized therefor without issue and intestate, the land escheats to the lord of the fee. Originally a bastard was deemed incapable of holy orders, and disqualified by the fact of his birth from holding any dignity in the church; but this doctrine is now obsolete, and in all other respects there is no distinction between a bastard and another man. By the law of Scotland a bastard is not only excluded from his father's succession, because the law knows no father who is not marked out by marriage; and from all heritable succession, whether by the father or mother, because he cannot be pronounced lawful heir by the inquest in terms of the brief; but also from the movable succession of his mother, because he is not her lawful child, and legitimacy is implied in all succession deferred by the law. But a bastard, although he cannot succeed *jure sanguinis*, may succeed by destination, where he is specially called to the succession by entail or testament. In Scotland, as in England, a bastard can have no legal heirs except those of his own body; and hence, failing his lawful issue, the king succeeds to him as last heir. In Scotland bastards may be legitimized in two ways; either by the subsequent intermarriage of the mother of the child with the father, as already mentioned, or by letters of legitimation from the sovereign. With respect to the last, however, it is to be observed, that letters of legitimation, be their clauses ever so strong, cannot enable the bastard to succeed to his natural father; for the king cannot, by any prerogative, cut off the private right of third parties. But, by a special clause in the letters of legitimation, he may renounce his right to the bastard's succession, failing descendants, in favour of him who would have been the bastard's heir had he been born in lawful wedlock, such renunciation encroaching upon no right competent to any third party. Formerly bastards in Scotland without issue of their own could not make a will, but this disability was removed by 6 Will. IV. c. 22. If bastards or other persons without kindred die intestate without wife or child, their effects go to the king as *ultimus heres*; but a grant is usually made of them by letters patent, and the grantee becomes entitled to the administration.

The conflict of laws on the subject of legitimation by subsequent marriage yields some curious results. Thus, in the case of *Burton v. Vardill*, it was decided that a child born in Scotland of parents domiciled there, not married till after his birth, is legitimate by the law of Scotland, but cannot take real estate in England as heir. Again, a domiciled Scotchman had a son born in Scotland and then married the mother in Scotland. The son died seized of land in England, and it was held that the father could not inherit from the son. A domiciled Englishman, putative father of a child born in France of a French woman, having afterwards acquired a French domicile, married the mother and acknowledged the child as legitimate in the mode prescribed by the law of France. It

was held that he could not legitimize the child so as to enable it to share in a bequest to his children by a person in England. The law of England, while admitting the general maxim that the *status* of legitimacy must be tried by the law of the country where it originates, holds that the succession to real property must be determined by the *lex loci rei sitæ*; so that, for example, a legitimized Scotchman would be recognized as legitimate in England, but not legitimate so far as to take lands as heir.

The statistics of illegitimacy present some striking differences and uniformities, but it is only in the case of Scotland that we can be reasonably certain of the accuracy of the figures. The status of the child is not recorded in the English system of registration, but is a matter of inference from the facts stated by the parents. In 1873 illegitimacy varied in Scotland as follows. The proportion of illegitimate births was—

In the Insular rural districts.....	5.4 per cent.
" Mainland rural districts.....	10.8 "
" Small towns.....	8.2 "
" Large towns.....	7.0 "
" Principal towns.....	9.1 "

In the counties the percentage varied from 4 in Shetland, Ross, and Cromarty, 5 in Nairn, and 6.5 in Sutherland, to 11.1 in Forfar, 11.4 in Roxburgh, 13.7 in Kincardine, 14 in Aberdeen, 15.8 in Banff, 15.8 in Elgin and Dumfries, and 18.4 in Wigton. Similar variations are shown by English statistics for 1859. Compare the highest (Cumberland, 11.4; Norfolk, 10.7; Westmoreland, 9.7) with the lowest (Monmouth and Middlesex, 4.7; and Surrey, 5). The metropolis stands at 4.2. With these local variations may be contrasted the steadiness with which the general average of illegitimacy is maintained. In England, for example, during nineteen years (1841-1859) the percentage fluctuated between 6.37 and 7, and during the last thirteen years of the period between 6.4 and 6.8. The returns of the Registrar-General show rather more fluctuation in Scotland during the period for which we have statistics (1855-1873), the figures being 7.8 in 1855, 8.5 in 1856, steadily rising to 10 in 1863, and 10.2 in 1866, and then steadily falling to 9.1 in 1872, and 9 in 1873. The statistics of different countries, so far as any proper comparison can be made between them, show differences equally remarkable. The order in which they stand, would be something like the following:—Sardinia (illegitimates), 2.091 per cent.; Holland, 3.96; Spain, 5.6; Switzerland, 5.9; Tuscany, 6; England, 6.5; Finland, Belgium, Sicily, France, 7.8; Prussia, 7 to 8, Austria, Norway, Scotland, 9; Denmark, Sweden, Hanover, Iceland, Saxony, 15; Würtemberg, Bavaria, 20 (from Mr Lumley's paper in the *Journal of the Statistical Society* for June 1862). It will be seen that these differences cannot be explained on any consideration of religious belief or education. An inquiry made in Prussia in 1849 yielded the following results. The proportion of illegitimate to legitimate births was—

Among Protestants.....	1 to 10.78
" Catholics.....	1 to 16.35
" Mennonites.....	1 to 57.88
" Jews.....	1 to 40

English and Scotch returns show that the proportion of illegitimacy is smaller in the town than in the country districts, but the same feature is not observed in Continental towns, as appears from the following returns, which, however, can in most cases be regarded as approximations only:—

In London the proportion is.....	4.2 per cent.
Birmingham, 1845.....	4.5 "
Liverpool, ".....	4 "
Manchester, ".....	6.7 "
Louis, ".....	6.4 "

In Glasgow,	1861 the proportion is	8·6	} per cent.
Edinburgh,	1856	9·4	
Edinburgh,	1878	7·6	} "
Edinburgh,	1878	8·3	
Paris,	1851	26·75	} "
Paris,	1858	26·35	
St Petersburg,	1823-29	18·80	} "
Stockholm,	1831-35,	40·7	
Vienna,	1861,	51·7	} "
Milan,	"	34·0	
Prague,	"	46·7	} "

(M. R.)

**BASTI**, a district of British India, in the Benares division, under the jurisdiction of the Lieutenant-Governor of the N.W. Provinces, situated between 26° 23' and 27° 30' N. lat., and 82° 17' and 83° 19' 30" E. long. It is bounded on the N. by the independent state of Nepal, on the E. by the district of Gorakhpur, on the S. by the Ghagra River, and on the W. by the district of Gondá in Oudh. The district stretches out in one vast marshy plain, draining towards the south-east, and traversed by the Rapti, Kuná, Bangangá, Masdih, Jamwár, Amf, and Katnehiá rivers. The tract lying between these streams consists of a rich alluvial deposit, more or less subject to inundations, but producing good crops of wheat and barley. Area of the district, 2787 square miles; population in 1872, 1,472,994 souls, residing in 6911 villages or townships, and 248,268 houses. The Hindus numbered 1,247,201; the Mahometans, 225,784; Christians, &c., 9 only. The Hindus, principally Rajput, belong to various clans. No manufacturing communities exist in the district, the entire population being cultivators. Rice and millet are the chief agricultural products. In 1870-71 the total revenue of the district amounted to £141,630, of which £132,274, or 93 per cent., was from land; the total expenditure amounting to £9518, 12s. The chief towns are—Mihdawal, population 8124; Basti, population 5087. The cost of the regular police force (exclusive of the village watch) was £15,896. In 1872-73 Basti contained 185 schools, attended by 6810 pupils. The land revenue settlement was made for thirty years in 1864, with that of the district of Gorakhpur, of which Basti formed a part till 1865, when it was erected into a separate district.

**BASTIA**, a fortified town and seaport on the eastern coast of the island of Corsica, and the capital of an arrondissement. Lat. 42° 41' 36" N., long. 9° 27' 22" E. It occupies a very picturesque situation, rising from the sea in the form of an amphitheatre; but the town itself is ill-built, and the streets are narrow and crooked. The harbour, which is defended by a citadel, has a narrow and difficult entrance. Bastia is the seat of a royal court for the island, and of tribunals of commerce and primary jurisdiction, and has a theatre, a military and a civil hospital, a communal college, a model school, a museum, and a library of 30,000 volumes. Its principal manufactures are soap, leather, liqueurs, and wax; and it exports oil, wine, coral, and various other products, being the principal seat of the import and export trade of the island. Bastia dates from the building of the Genoese Castle by Lionello Lomellino in 1383, and derives its name from the Bastion of St Charles. Under the Genoese it was long the principal stronghold in the north of the island, and the residence of the governor; and, in 1553, it was the first town attacked by the French. On the division of the island in 1797 into the two departments of Golo and Liamona, Bastia remained the capital of the former; but when the two were again united Ajaccio obtained the superiority. The city was taken by the English in 1745, and again in 1794. Population, 21,535. (See view in Lear's *Jour. in Corsica*, 1870.)

**BASTIAT**, FREDERIC, the son of a merchant of Bayonne, was born in that town on the 19th of June 1801. After

being educated at the Colleges of Saint-Sever and of Sorèze, he entered in 1818 the counting-house of his uncle at Bayonne. Here his intensely active mind soon began to interest itself in the study of the principles of commerce, but he felt no enjoyment in the practical routine of mercantile life, and in 1825 retired to a property at Mugron, of which he became possessor on the death of his grandfather. Thus withdrawn from society, he devoted himself with eagerness to meditation and study, mastering the English and Italian languages and literatures, speculating on the problems of philosophy and religion, digesting the doctrines of Adam Smith and Say, of Charles Comte and Dunoyer, cultivating music, experimenting in farming, and talking over all that he read, thought, and desired, with his able, dearly loved, and life-long friend, M. Felix Coudroy. He welcomed with enthusiasm the Revolution of 1830. In 1831 he became a justice of peace of Mugron, and in 1832, a member of the Council-General of the Landes. In 1834 he published his first pamphlet. In 1840 he visited Spain and Portugal, and spent a few weeks in London. Between 1841-44 three pamphlets appeared from his pen, all, like his first brochure, on questions of taxation affecting local interests. During this period an accidental circumstance led him to become a subscriber to an English newspaper, the *Globe and Traveller*, through which he was made acquainted with the nature and progress of the crusade so vigorously and skilfully carried on by the Anti-Corn-Law League against Protectionist doctrines and practices. After closely studying the movement for two years he resolved to make his countrymen aware of its history and significance, and to inaugurate, if possible, a similar movement in France. To prepare the way he contributed in 1844 to the *Journal des Economistes* an article "Sur l'influence des tarifs Anglais et Français," which attracted great attention, and which he followed up by others, including the first series of his brilliant *Sophismes Economiques*.

In 1845 he came to Paris in order to superintend the publication of his *Cobden et la Ligue, ou l'agitation Anglaise pour la liberté des échanges*, and was very cordially received by the economists of the capital; from Paris he went to London and Manchester, and made the personal acquaintance of Cobden, Bright, and other leaders of the league. When he returned to France he found that his writings had been exerting a powerful influence; and in 1846 he assisted in organizing at Bordeaux the first French Free Trade Association. The rapid spread of the movement soon required him to abandon the sweet and fruitful leisure of his beloved Mugron for the feverish and consuming activity of Paris. During the eighteen months which followed this change his labours were prodigious. He acted as secretary of the central committee of the association, organized and corresponded with branch societies, waited on ministers, procured subscriptions, edited a weekly paper, the *Libre-Echange*, contributed to the *Journal des Economistes*, and to three other periodicals, addressed meetings in Paris and the provinces, and delivered a course of lectures on the principles of political economy to students of the schools of law and of medicine. The cause to which he thus devoted himself, with a zeal and a self-denial most admirable in themselves, but fatal to his own health and life, appeared for a time as if it would be as successful in France as in England; but the forces in its favour were much weaker and those opposed to it were much stronger in the former country than in the latter, and this became always the more apparent as the struggle proceeded, until it was brought to an abrupt end by the Revolution of February 1848. This event allowed the socialism and communism which had been gathering and spreading in secret during the previous thirty years to



show themselves openly and boldly in singularly favourable circumstances. Louis Blanc, Victor Considérant, Pierre Leroux, J. P. Proudhon, and other representatives of these theories laboured zealously and effectively to gain to them the needy and uneducated masses of their countrymen, and to discredit as utterly evil the existing order of society. In this grave crisis Bastiat nobly performed his duty. Although exhausted by the far too heavy labours in which he had been engaged, although robbed of his voice by the malady which was preying upon him, so that he could do but little to defend the truth from the tribune of the Constituent Assembly, he could still suggest wise counsels in the Committee of Finance of which he was vice-president, and he could still use his pen with a vigour and dexterity which made him capable of combating single-handed many opponents.

He wrote in rapid succession a series of brilliant and effective pamphlets and essays, showing how socialism was connected with protection, and exposing the delusions on which it rested. Thus within the space of two years there appeared *Propriété et Loi, Justice et Fraternité, Propriété et Spoliation, L'État, Baccalariet et Socialisme, Protectionisme et Communisme, Capital et Rente, Maudit Argent, Spoliation et Loi, Gratuité du Crédit, and Ce qu'on voit et ce qu'on ne voit pas*. While thus occupied he was meditating the composition of a great constructive work, meant to renovate economical science by basing it on the principle that "interests, left to themselves, tend to harmonious combinations, and to the progressive preponderance of the general good." The first volume of this work *Les Harmonies Économiques* was published in the beginning of 1850. In the autumn of that year, when working on the second volume, the increase of his malady compelled him to repair to Italy. After lingering at Pisa and Florence he reached Rome, but only to die there on the 24th of December 1850, in the fiftieth year of his age. An affecting account of the last days of this illustrious martyr to the cause of economical science and political justice was published by his friend, M. Paillotet.

The life-work of Bastiat, in order to be fairly appreciated, requires to be considered in three aspects. (1.) He was the advocate of free trade, the opponent of protection. The general theory of free trade had, of course, been clearly stated and solidly established before he was born, and his desire to see its principles acted on in France was quickened and confirmed by the agitation of the Anti-Corn-Law League for their realization in England, but as no one denies it to have been a great merit in Cobden to have seen so distinctly and comprehensively the bearing of economical truths which he did not discover, no one should deny it to have been also a great merit in Bastiat. He did far more than merely restate the already familiar truths of free trade. He showed as no one before him had done how they were applicable in the various spheres of French agriculture, trade, and commerce. Now, the abstract theory of free trade is of comparatively little value; its elaboration so as to cover details, its concrete application, and its varied illustration are equally essential. And in these respects it owes more, perhaps, to Bastiat than to any other economist. In the *Sophismes Économiques* we have the completest and most effective, the wisest and the wittiest exposure of protectionism in its principles, reasonings, and consequences which exists in any language. (2.) He was the opponent of socialism. In this respect also he had no equal among the economists of France. He alone fought socialism hand to hand, body to body, as it were, not caricaturing it, not denouncing it, not criticizing under its name some merely abstract theory, but taking it as actually presented by its most popular representatives, considering patiently their proposals and arguments, and proving conclusively that they proceeded on false principles,

reasoned badly, and sought to realize generous aims by foolish and harmful means. Nowhere will reason find a richer armoury of weapons available against socialism than in the pamphlets published by Bastiat between 1848 and 1850. These pamphlets will live, it is to be hoped, at least as long as the errors which they expose. (3.) He attempted to expound in an original and independent manner political economy as a science. In combating, first, the Protectionists, and, afterwards, the Socialists, there gradually rose on his mind a conception which seemed to him to shed a flood of light over the whole of economical doctrine, and, indeed, over the whole theory of society, viz. the harmony of the essential tendencies of human nature. The radical error, he became always more convinced, both of protectionism and socialism, was the assumption that human interests, if left to themselves, would inevitably prove antagonistic and anti-social, capital robbing labour, manufactures ruining agriculture, the foreigner injuring the native, the consumer the producer, &c.; and the chief weakness of the various schools of political economy, he believed he had discovered in their imperfect apprehension of the truth that human interests, when left to themselves, when not arbitrarily and forcibly interfered with, tend to harmonious combination, to the general good. Such was the point of view from which Bastiat sought to expound the whole of economical science. The sphere of that science he limited to exchange, and he drew a sharp distinction between utility and value. Political economy he defined as the theory of value, and value as "the relation of two services exchanged." The latter definition he deemed of supreme importance. It appeared to him to correct what was defective or erroneous in the conflicting definitions of value given by Adam Smith, Say, Ricardo, Senior, Storch, &c., to preserve and combine what was true in them, and to afford a basis for a more consistent and developed economical theory than had previously been presented. It has, however, found little acceptance, and Roscher, Cairnes, and others seem to have shown it to be ambiguous and misleading. A consequence of it on which he laid great stress was that the gratuitous gifts of nature, whatever be their utility, are incapable of acquiring value,—what is gratuitous for man in an isolated state remaining gratuitous for him in a social condition. Thus, land, according to Bastiat, is as gratuitous to men at the present day as to their first parents, the rent which is paid for it—its so-called value—being merely the return for the labour and capital which have been expended on its improvement. In the general opinion of economists he has failed to establish this doctrine, failed to show that the properties and forces of nature cannot be so appropriated as to acquire value. His theory of rent is nearly the same as Mr Carey's, i.e., decidedly anti-Ricardian. His views on the growth of capital and interest, on landed property, competition, consumption, wages, and population, are independent, and, if not unqualifiedly true, at least richly suggestive. His *Œuvres Complètes* are in 7 vols. The first contains an interesting *Memoir* by M. Paillotet. The following articles on Bastiat may be specified,—Eyrebaud's in the *Revue des Deux Mondes*, Sept. 1, 1858; Macleod's in his *Dictionary of Political Economy*; and that of Cairnes in the *Fortnightly Review*, Oct. 1, 1870. There is a good statement of his distinctive views in Kautz, *Geschichte der National-Oekonomie*, ii. 578-584. His *Harmonies* have been well translated by Dr P. J. Stirling. (R. F.)

BASTILLE (from *bastir*, now *bâtir*, to build), in the earlier use of the word, was any fortified building forming part of a system of defence or attack; and the name was especially applied to several of the principal points in the ancient fortifications of Paris. In the reign of king John, or even earlier, the gate of Saint Antoine was flanked

by two towers, and in 1369 Hugues Aubriot, at the command of Charles V., changed it into a regular bastille or fort by the addition of six others of massive structure, the whole united by thick walls and surrounded by a ditch 25 feet wide. Various extensions and alterations were afterwards effected; but the building remained substantially what it was made by the vigorous provost, a strong and gloomy structure, with eight stern towers. As the ancient fortifications of the city were superseded, the use of the word bastille as a general designation gradually died out, and it became restricted to the castle of Saint Antoine, the political importance of which made it practically, long before it was actually, the only bastille of Paris. The building had originally a military purpose, and it appears as a fortress on several occasions in French history. When Charles VII. retook Paris from the English in 1436, all his opponents in the city took refuge in the Bastille, which they were prepared to defend with vigour, but the want of provisions obliged them to capitulate. In 1588 the duke of Guise took possession of the Bastille, gave the command of it to Bussy-Leclerc, and soon afterwards shut up the whole parliament within its walls, for having refused their adherence to the League. When Henri IV. became master of Paris he committed the command of the Bastille to Sully, and there he deposited his treasures, which at the time of his death amounted to the sum of 1,870,000 livres. On the 11th of January 1649, the Bastille was invested by the forces of the Fronde, and, after a short cannonade, capitulated on the 13th of that month. The garrison consisted of only twenty-two men. The Frondeurs concluded a peace with the court on the 11th of March; but it was stipulated by treaty that they should retain possession of the Bastille which, in fact, was not restored to the king till the 21st of October 1651. In that year took place the famous fight of the Porte St Antoine between Condé and Turenne, on which occasion the forces of Condé owed their safe retreat into Paris to the cannon of the Bastille.

At a very early period, however, the Bastille was employed for the custody of state prisoners, and it was ultimately much more of a prison than a fortress. According to the usual account, which one is tempted to ascribe to the popular love of poetical justice, the first who was incarcerated within its walls was the builder himself, Hugues Aubriot. Be this as it may, the duke of Nemours spent thirteen years there in one of those iron cages which Louis XI. called his *fillettes*; and Jacques d'Armagnac, Poyet, and Chabot were successively prisoners. It was not till the reign of Louis XIII. that it became recognized as a regular place of confinement: but from that time till its destruction it was frequently filled to embarrassment with men and women of every age and condition.

Of the treatment of prisoners in the Bastille very various accounts have been given even by those who speak from personal experience, for the simple reason that it varied greatly in different cases. The prisoners were divided into two main classes, those who were detained on grounds of precaution or by way of admonitory correction, and those who lay under presumption or proof of guilt. The former were subject to no investigation or judgment, and the length of their imprisonment depended on the will of the king; the latter were brought to trial in the ordinary courts or before special tribunals, such as that of the Arsenal.—though even in their case the interval between their arrest and their trial was determined solely by the royal decree, and it was quite possible for a man to grow old in the prison without having the opportunity of having his fate decided. Until guilt was established, the prisoner was registered in the king's name, and—except in the case of state prisoners of importance, who were kept with greater strict-

ness and often in absolute isolation—he enjoyed a certain degree of comfort and freedom. Visitors were admitted under restrictions; games were allowed; and, for a long time, at least, exercise was permitted in open parts of the interior. Food was both abundant and good, at least for the better class of prisoners; and instances were not unknown of people living below their allowance and, by arrangement with the governor, saving the surplus. When the criminality of the prisoner was established, his name was transferred to the register of the "commission," and he became exposed to numerous hardships and even barbarities, which, however, belonged not so much to the special organization of the Bastille as to the general system of criminal justice then in force.

Among the more distinguished personages who were confined in this fortress during the reigns of Louis XIV., XV., and XVI., were the famous *Man of the Iron Mask*, Fouquet, the Marshal Richelieu, Le Maître de Saoy, De Ranneville, Voltaire, De Latude, Le Prévost de Beaumont, Labourdonnais, Lally, Cardinal Rohan, Linguet, and La Chalotais. While no detestation is too great for that system of "royal pantheism" which led to the unjust and often protracted imprisonment of even men of great ability and stainless character, it is unnecessary to give implicit credence to all the tales of horror which found currency during the excitement of the Revolution, and which historical evidence, as well as *a priori* considerations, tends to strip of their more dreadful features, and even in many cases to refute altogether. Within the last twenty or thirty years much light of an unexpected kind has been shed on the history of the Bastille from the pages of its own records. These documents had been flung out into the courts of the building by the Revolutionary captors and after suffering grievous diminution and damage were finally stored up and forgotten in the vaults of the library of the (so-called) Arsenal. Here they were discovered in 1840 by François Ravaisson, who has since devoted himself, with rare patience, learning, and ability, to their arrangement, elucidation, and publication. Of the extent and value of his investigations some idea may be formed from the fact that the six volumes published cover only the interesting period from 1659 to 1681.

At the breaking out of the Revolution the Bastille was attacked by the Parisians; and, after a vigorous resistance, it was taken and razed to the ground on the 14th July 1789. At the time of its capture only seven prisoners were found in it. A very striking account of the siege will be found in Carlyle's *French Revolution*, vol. i. The site of the building is now marked by a lofty column of bronze, dedicated to the memory of the patriots of July 1789 and 1830. It is crowned by a gilded figure of Mercury spreading his pinions in the act of flight.

See the *Histories of the Bastille* by Renneville (7 tom. 12mo, 1713–24), Fougaret (8vo, 1833), Dufey de l'Yonne (8vo, 1834), and Arnould (7 tom. 8vo, 1843–44); and the *Memoirs of Linguet* (12mo, 1821, new ed.), Carra (3 tom. 8vo, 1787), Charpentier (3 tom. 8vo, 1789), and Latude (edited by Thierry, 3 tom. 18mo, 1791–92); also François Ravaisson, *Les Archives de la Bastille*, (6 vols. 8vo, 1866–73), and Charles Louandre, in *Revue des Deux Mondes*, 1874.

BASTWICK, DR JOHN, born at Writtle, in Essex, in 1593, was a physician at Colchester, whose celebrity rests on his strong opposition to the Roman Catholic ceremonial. About 1633 he printed in Holland a Latin treatise, entitled *Elenchus Religionis Papiasticae, with Flagellum Pontificis et Episcoporum Latialium*; and as the English prelates thought themselves aimed at, he was fined £1000 in the High Commission Court, excommunicated, and prohibited from practising physic, while his books were ordered to be burnt, and the author himself consigned to prison. Instead of

recanting, however, he wrote *Apologues ad Prasules Anglicanos*, and another book called *The Litany*, in which he exclaimed vehemently against the proceedings of that arbitrary court, and charged the bishops with an inclination to popery. Prynne and Burton coming under the lash of the Star-chamber court at the same time, they were all censured as turbulent and seditious persons, and condemned to pay a fine of £5000 each, to be set in the pillory, to lose their ears, and to undergo imprisonment for life in remote parts of the kingdom. The parliament in 1640 reversed these proceedings, and ordered Bastwick a reparation of £5000 out of the estates of the commissioners and lords who had persecuted him. The civil commotions which ensued prevented his receiving this *solutio* for his sufferings; but, in 1644, his wife had an allowance ordered for her own and her husband's maintenance. The place and time of his death are unknown. He seems in his later years to have shown a bitter opposition to the Independents.

BAT, the common name of a well marked group of Mammals forming the order *Cheiroptera* (i.e., wing-handed), distinguished from all other members of their class by the possession of true organs of flight. These consist of a delicate membrane stretching from limb to limb on both sides of the body, enclosing the greatly elongated digits of the hand, and in many cases extending beyond the posterior limbs so as to include the tail. Their whole structure bears evidence of special adaptation to the purpose of sustained flight, while their mode of progression on the ground is as awkward as their aerial movements are graceful. The eyes of the bat are usually small, but the organs of the other senses in most cases attain extraordinary development. The external ear is generally large, as in the Long-eared Bat of Britain (*Plecotus auritus*), in which it is equal to the entire length of the body. In the group to which the Horse-shoe Bats (*Rhinolophus ferrum equinum*) belong, the nose is surrounded with leaf-like appendages, the purpose of which is by no means well determined, but which, probably, are as useful to the organ of smelling as is the greatly elongated auricle to that of hearing. In all bats the wing-membrane affords a vast expansion of the sense of touch, which is of such exquisite delicacy that bats which have been deprived of their sight, and as far as possible of hearing and smelling, are yet able by it alone to fly about in perfect security, avoiding, with apparent ease, all the obstacles that may be placed in their way. By Pliny and other early naturalists the bat, although known to suckle its young, was placed among Birds, and was generally regarded as a creature of ill omen, a superstitious feeling by no means extinct at the present day. Virgil, in speaking of the Harpies, generally understood to have been bats, describes them as "diræ obscensque volucres." Our English ancestors formed a more correct estimate of the zoological position of these creatures as indicated by the name "fitter-mouse," still given to the bat in many parts of Britain. Bats are nocturnal or crepuscular in their habits, remaining suspended by day in the darkest recesses of woods and caverns, or in the most inaccessible parts of unfrequented buildings, and coming forth at twilight in search of food. This in the species found in Europe and America consists mainly of insects; while one species at least, the Vampire of America, sucks the blood of other mammals, although its powers in this respect have probably been much exaggerated. The Fruit-eating Bats (*Pteropus*) are confined to the warmer regions of Asia and Africa, and among these are to be found the largest members of the order, thus the Kalong of Java (*Pteropus javanicus*) measures 5 feet between the tips of its wings. In countries where the winter cold is sufficiently severe to cut off their usual sources of food, bats hibernata. Collecting in

enormous numbers in their usual retreats and suspending themselves by their hind limbs, they become torpid, and remain so till the return of spring, bringing with it a revival of insect life, restores them to their wonted activity. About 130 species of bats are known, and these are widely distributed over every quarter of the globe, extending as far northward as latitude 60°; all the larger forms, however, occur in the warmer regions of the earth. Bats are found in most of the islands of the Indian and Pacific Oceans, forming in many of them the only indigenous mammals, a fact readily explained when viewed in connection with their remarkable power of flight. Fossil remains of insectivorous Cheiroptera have been found in the Eocene and later Tertiary deposits. See MAMMALIA.

BATAVIA, a large city and seaport on the north coast of the island of Java, and the capital of all the Dutch settlements in the East. It is situated on both sides of the river Jacatra or Tjilivong, in a swampy plain at the head of a capacious bay. The streets are for the most part straight and regular, and many of them have a breadth of from 100 to 200 feet. In several cases there is a canal in the centre lined with stone, and defended by low parapets or banks, while almost every street and square is fringed with trees. The old town has greatly changed from what it was in the 18th century. It was then surrounded by strong fortifications, and contained a number of important buildings, such as the town-house (built in 1652 and restored in 1706), the exchange, the infirmary and orphan asylum, and the European churches. But the ramparts were long ago demolished, and most of the public edifices have either fallen into decay or been converted into magazines and warehouses. The great church which was finished in 1760, at an expense of £80,000, had to be taken down in consequence of its foundation having given way. Canals have been filled up, streets have been altered, and the general character of the place considerably modified. All the European inhabitants, except those immediately connected with the shipping, have removed to the New Town, which has been gradually formed by the integration of Weltevreden (*Well-content*), Molenvliet (*Mill-stream*), Rijswijk (*Rice-town*), Noordwijk (*North-town*), Koningsplein (*King's square*), and other suburban villages or stations. The situation of this modern part is higher and healthier; and the grandeur and variety of its buildings far surpass anything to be found in the older section of the city. The misplaced imitation of Dutch arrangements has been happily avoided, and the natural advantages of the situation and climate have been turned to account. The houses are frequently separated from each other by rows of trees.

As the chief city of the Dutch colonies in the East, Batavia contains numerous buildings connected with the civil and military organisation of the Government. The chambers of the Council of the East Indies occupy a spacious edifice in Rijswijk, and the governor-general's hotel, or town-residence, is situated in the same quarter. In the district of Weltevreden are the new palace, the barracks, and the artillery school, as well as the military and civil hospital, which can accommodate 600 patients, and not far off is the Frederik-Hendrik citadel, which was built in 1837. Further inland, at Meester Cornelis (known for its lake), is a school for under-officers. The Koningsplein is a large open square for military manoeuvres, about 390 feet long and 250 feet broad, surrounded by mansions of the wealthier classes. Noordwijk is principally inhabited by lesser merchants and subordinate officials. There is an orphan-asylum in the district of Parapatta, and a poor-house (*Diaconis armenhaus*) in Molenvliet. Besides those already mentioned, Batavia has various educational and scientific institutions of note. In 1851 the Government founded a medical school for

Javanes, and in 1860 the "Gymnasium William III." in which a comprehensive education is bestowed. A society of arts and sciences was established in 1778, a royal physical society in 1850 and a society for the promotion of industry and agriculture in 1853. In addition to the *Transactions* of these societies—many of which contain valuable contributions to their respective departments in their relation to the East Indies—a considerable number of publications are issued in Batavia. Among miscellaneous buildings of importance may be mentioned the public-hall known as the *Harmonie*, the freemasons' lodge, the theatre, the club-house, and several fine hotels.

The population of Batavia is very varied—the Dutch residents being a comparatively small class, and greatly intermixed with Portuguese and Malays. Here are found members of the different Indian nations originally slaves: Moors and Arabs, who are principally engaged in navigation, but also inhabit the *Rua Malacca* district, and trade in gold and precious stones; Javanes, who are cultivators; and Malays, chiefly boatmen and sailors, and adherents of Mahometanism. But, perhaps, the most important Asiatic element is the Chinese, who are both numerous and industrious. They were long greatly oppressed by the Dutch Government in various paltry ways, and in 1740 they were massacred to the number of 12,000. But in spite of all this they have maintained their position, and now enjoy a happier lot. In 1832 the population was found to consist of 2800 Europeans, 80,000 natives, 25,000 Chinese, 1000 Arabs, and 9500 slaves—a total of 118,300 persons. The number of inhabitants is at present much less.

Batavia is still a great commercial depot, though it has had to contend against the rivalry of Singapore. The bay is rendered secure by a number of islands at its mouth, and is capacious enough for a much larger traffic than it has ever seen; but it unfortunately grows very shallow towards the shore. Ships of 300 or 400 tons anchor about a mile and a half out; the river is navigable a couple of miles inland for vessels of 30 or 40 tons, but the entrance is narrow, and requires continual attention to keep it open.

The exports from Batavia to the other islands of the archipelago, and to the ports in the Malayan peninsula, are rice, sago, coffee, sugar, salt, oil, tobacco, teak timber and planks, Java cloths, brass wares, &c., and European, Indian, and Chinese goods. The produce of the Eastern Islands is also collected at its ports for re-exportation to India, China, and Europe,—namely, gold-dust, diamonds, camphor, benzoin, and other drugs; edible bird-nests, trepang, rattans, bees' wax, tortoise-shell, and dyeing woods from Borneo and Sumatra; tin from Banca; spices from the Moluccas; fine cloths from Celebes and Bali; and pepper from Sumatra. From Bengal are imported opium, drugs, and cloths; from China, teas, raw silk, silk piece-goods, varnished umbrellas, coarse China wares, nankeen, paper, and innumerable smaller articles for the Chinese settlers. British manufactures also are largely introduced. The number of British ships that entered in 1870 was 103, with a tonnage of nearly 31,000 tons, the total number of vessels of all nationalities being 783, with a tonnage of nearly 194,000.

Almost the only manufactures of any importance are the distillation of arrack, which is principally carried on by Chinese, the burning of lime and bricks, and the baking of pottery; and even the brick-making is in a decaying condition. The principal establishment for monetary transactions is the Java Bank, established in 1828 with a capital of £500,000; but there are also agencies belonging to the Bank of Rotterdam, and the Chartered Bank of India, Australia, and China, as well as a public savings bank.

The Government has a naval establishment at the island

of Onrust, about six miles from the city; and among its other accommodations is a large iron floating dock capable of holding vessels 400 feet long. Since 1869, however, entrance has been refused to merchant ships, which, consequently, feel the lack of proper docks in the harbour. Proposals to build these and to extend the harbour, though frequently under discussion, have had no result. Tramways were introduced into the city in 1867, and are greatly patronized by the native population. A railway to Buitenzorg, where the Government botanical gardens are situated, was opened in 1871, the distance being about 40 miles inland.

Batavia owes its origin to the Dutch general John Petersen Coen, who, in 1619, took the town of Jacatra (which had been built on the ruins of the old Javanes town of Sunda Calappa), destroyed it, and founded in its stead the present city, which soon acquired a flourishing trade and increased in importance. The ruins of Jacatra are to be found between Batavia and Anjol. In 1699 Batavia was visited by a terrible earthquake, and the streams were choked by the mud from the volcano of Gunung Salak (7244 feet high), by which the climate was so affected that the city became notorious for its unhealthiness, and was in great danger of being altogether abandoned. In the twenty-two years from 1730 to 1752, 1,100,000 deaths are said to have been recorded. General Daendels, who was governor from 1808 to 1811, caused the ramparts of the town to be demolished, and began to form the nucleus of a new city at Weltevreden. By 1816 nearly all the Europeans had left the old town. In 1811 a British armament was sent against the Dutch settlements in Java, which had been incorporated by France, and to this force Batavia surrendered on the 8th of August. It was restored, however, to the Dutch by the treaty of 1814.

See Stavrinus, *Voyages to the East Indies*; Barrow, *Voyage to Cochin China*; Sir George Staunton, *Embassy to China*; Daendels, *Statut der Nederl. O. Ind. Bestittingen*; Junghuhn, *Reisen der Java*; Thun, *Mem. of the Conquest of Java*; Sir S. Raffles, *History of Java*; Temminck, *L'Inde Archip.*; Yeth, *Woordenboek v. Nederl. Ind.*

BATES, WILLIAM, D.D., an eminent Nonconformist divine, born in November 1625. He was admitted to Emmanuel College, Cambridge, and removed thence to King's College in 1644. He was one of the commissioners at the conference in the Savoy, for reviewing the public liturgy, and was concerned in drawing up the exceptions to the Book of Common Prayer. Notwithstanding this he was appointed chaplain to Charles II. soon after the Restoration, and became minister of St Dunstan's in the West; but he was afterwards deprived of his benefice for nonconformity. Bates was of an amiable character, and enjoyed the friendship of the Lord-Keeper Bridgeman, the Lord-Chancellor Finch, the earl of Nottingham, and Archbishop Tillotson. He published *Select Lives of Illustrious and Pious Persons*, in Latin; and after his death all his works, except his *Select Lives*, were printed in one vol. fol.; again in 1723; and in 4 vols. 8vo. in 1815. He died in July 1699, in the 74th year of his age.

BATH, the chief town of Somersetshire, and, from the elegance of its buildings and the beauty of its situation, one of the finest cities in England, is situated mainly on the right bank of the river Avon, though a considerable extension has also taken place on the left. Communication between the two portions is afforded by several bridges, of which the most important are the Pulteney, the North Parade, the Cleveland, and the Grosvenor Suspension. The heights and slopes of the great western oolitic range, that rise like an amphitheatre from the river valley, are covered with the terraces and crescents of the city; it contains many fine public walks, and the vicinity presents a great variety of beautiful landscape. Its sheltered position renders the climate mild and agreeable. The houses are

mostly built of white freestone. Jointly with Wells, Bath is the head of a diocese, which is co-extensive with the county of Somerset. The Abbey Church is a handsome

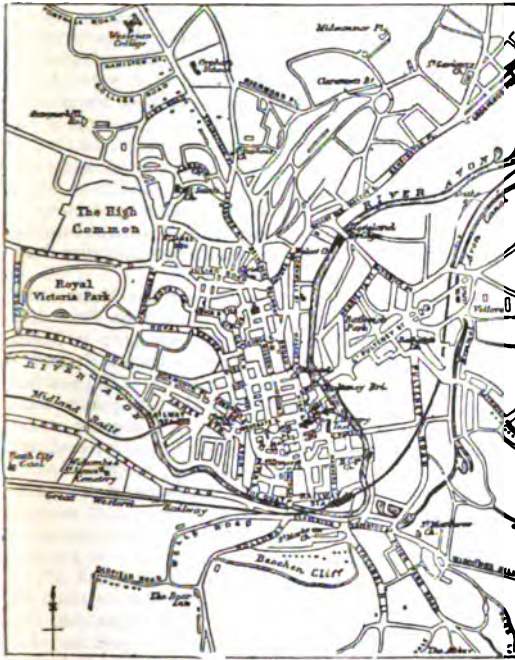

Sketch Ground-Plan of Bath.

- |                    |                             |                          |
|--------------------|-----------------------------|--------------------------|
| 1. Guildhall.      | 4. Market.                  | 8. Cross Bath.           |
| 2. Assembly Rooms. | 5. Pump-Room.               | 9. Hot Bath Pump-Room.   |
| 3. Theatre.        | 7. King's and Queen's Bath. | 10. Kingston Baths.      |
| 4. Post-Office.    |                             | 11. Royal Private Baths. |

cruciform edifice, dating from 1499, with a quadrangular tower 162 feet high rising from the point of intersection. It is 210 feet in length from E. to W., and 126 in breadth from N. to S. The west front contains a curious representation of the founder's dream of the angels ascending and descending on Jacob's ladder. In the interior are the tombs of Quin, Nash, Malthus, Broome, Melmoth, and numerous minor celebrities; while several of the monuments are from the chisels of Bacon, Chantrey, and Flaxman. The church has been recently restored under the direction of Sir Gilbert Scott, at a cost of £20,000. There are about thirty other parish churches or chapels in Bath, as well as numerous nonconformist places of worship. St Swithin's, Walcot, may be mentioned as containing the tombs of Christopher Anstey and Madame d'Arblay. Among the most important educational institutions are the Free Grammar School, founded by Edward VI.; the Somersetshire College, established in 1858; the Royal School, for the education of the daughters of military officers, founded in 1865; the Bath College in Sydney Place; the School of Art; the Roman Catholic College at Prior Park, which was formerly the mansion of Ralph Allen, the friend and patron of Fielding; and the Wesleyan College at Kingswood. There are several buildings of considerable pretension connected with the baths from which the town derives its name. The springs supply six distinct establishments, namely, the King's, Queen's, Hot, Cross, Abbey, and Grand Pump Room Hotel baths. Of these the oldest is the King's,



Device of Bishopric.

which was enclosed in 1236. The pump-room is 85 feet in length by 56 in breadth and 34 in height; it contains a marble statue to Beau Nash. The Queen's was built in 1597; and the Cross Bath dates from 1790. The temperature varies in the different springs from 117° to 120° Fahr., and the specific gravity of the hot bath is 1.002. Dr Daubeny in 1833 found that the daily evolution of nitrogen gas amounted to 250 cubic feet; and Professor Ramsay has calculated that if the mineral ingredients of the waters were solidified they would form in one year a column 9 feet in diameter and 140 feet in height. The principal substances in solution are sulphates of lime and soda and chlorides of sodium and magnesium. The waters are very beneficial in cases of palsy, rheumatism, gout, leprosy, neuralgia, sciatica, chorea, diseases of the liver, and cutaneous and scrofulous affections. The influx of visitors, varying from 10,000 to 14,000 during the season, has greatly stimulated the adornment of the town. The Assembly rooms, built by Wood the younger, at a cost of £20,000, were opened in October 1771, and for elegance, comfort, and convenience, are not surpassed by any similar rooms in the kingdom. The theatre, which is one of the best out of London, was opened in 1863, the former building having been burnt in 1862. The Literary and Scientific Institution, founded in 1826, is a handsome building of the Doric order, and contains a laboratory, a lecture-room, a museum (with numerous Roman antiquities and ornithological specimens), and an extensive library, in which is the Chapman collection illustrative of the history of Bath. The Rev. Leonard Blomefield (late Jenyns) has presented his fine library of natural history and science (including his herbarium) to the institution. The Guild-hall, with an elegant Grecian front, was founded in 1766; and the market-halls were reconstructed about 1863. Among the charitable institutions are the Mineral Water Hospital, opened in 1742, and extended in 1861; the Royal United Hospital, opened in 1826; Bello's Hospital, which dates from 1611, though the present building was erected in 1859; St Catherine's Hospital, founded by Edward VI.; St John's, founded by Bishop Fitz Joceline in 1174; and the Ear-and-Eye Infirmary, established in 1837. There are six banks, besides a savings-bank. The Sydney gardens have been open since 1795, and are frequently employed for public exhibitions and amusements; the Victoria Park, opened by the queen, when Princess Victoria, in 1830, is such as any city might be proud of. The corporation consists of a mayor, fourteen aldermen, and forty-two councillors, and the town returns two members to parliament. Several newspapers are published weekly. The Great Western Railway connects Bath with London, Bristol, Salisbury, Wells, Weymouth, &c., from the first of which it is 107 miles distant; the Midland line is connected with Bath by a junction at Mangotsfield; and ready access to the south has recently been obtained by the opening of the Somerset and Dorset line. The Kennet and Avon canal, which joins the Thames at Reading, affords water communication with the metropolis. The population of the municipal borough was 54,240 in 1851, 52,528 in 1861, and 52,557 in 1871, nearly 60 per cent of the last number being females. In 1871 the parliamentary borough contained 53,704 persons.



City Arms.

According to the legend to which the inhabitants adhered till the middle of the 18th century, Bath was founded by the British king Bladud; but its origin cannot be historically traced to an earlier date than the 1st century, when the Romans established here the city of *Aqua Solis*, numerous remains of which have at various times been

discovered. During the Saxon period the chief events in its annals are the foundation of an abbey by Offa in 775, and the coronation of Edgar in 973. In the reign of William Rufus the city was reduced to ashes, but it soon recovered its prosperity under its abbot John of Villula, and his successors. Richard Cœur de Lion granted its first charter as a free borough, and about the same time the foundations were laid of its wool manufactories. In 1297 the city was first represented in parliament; in 1447 it obtained a charter from Henry VI., and one from Queen Elizabeth in 1590. In the 18th century it became the most fashionable watering-place in England, and was greatly extended under the direction of the architect Wood.

See Warner's *History and Antiquities of Bath*, 1801; Mainwaring's *Collectanea*; C. P. Russell, *On the Growth of Bath*, read before the Arch. Inst., 1858; *Ancient Landmarks of Bath*, by C. E. Davis; Wright's *Hist. Guide to Bath*, 1864; Earle's *Guide to Bath*, 1864; Lyell's *Inaugural Address before Brit. Assoc.*, 1864; Sir G. Jackson's *Archives of Bath*, 3 vols., 1873; Peach, *Rambles about Bath*, 1875; Scarth, *Agua Solis, or Notices of Roman Bath*, 1864.

**BATH**, a city and port of the United States of North America, chief town of the county of Sagadahock in Maine. It is situated on the W. bank of the Kennebec, about twelve miles from the sea, and forms a station on the branch railway from Brunswick to Rockland. The prosperity of the town depends almost entirely on its shipping and fisheries; and its manufacturing industries are nearly all auxiliary to the one department of shipbuilding, in which it competes with the chief American centres of the trade. It has a fine custom-house built of granite. The city was settled in 1756, incorporated in 1780, and raised to the rank of a city in 1860. Population (1870), 7371.

**BATH, KNIGHTS OF THE.** See **HERALDRY** and **KNIGHTHOOD**.

**BATHGATE**, a town of Scotland, in the county of Linlithgow, 19 miles from Edinburgh, and 26 from Glasgow, with both which it has direct communication by railway. The town is irregularly built, and has no buildings of importance except a well-endowed academy. The district is rich in limestone, coal, shale, and ironstone, which afford employment to a large part of the population. Paraffin and chemicals are extensively manufactured, and there are glass-works and flour-mills. Population (1871), 4491.

**BATHS.** In the ordinary acceptation of the word a bath is the immersion of the body in a medium different from the ordinary one of atmospheric air, which medium is usually common water in some form. In another sense it includes the nature of the different media that may be used, and of the various arrangements by which they are applied. Perhaps the simplest method of presenting a general view of the whole subject is first to give an outline of the history of baths in all ages, and next to give some account of the principles on which baths act on the human system.

*Ancient Baths.*—Bathing, as serving both for cleanliness and for pleasure, has been almost instinctively practised by nearly every people. The most ancient records mention bathing in the rivers Nile and Ganges. From an early period the Jews bathed in running water, used both hot and cold baths, and employed oils and ointments. So also did the Greeks; their earliest and commonest form of bathing was swimming in rivers, and bathing in them was practised by both sexes. Warm baths were, according to Homer, used after fatigue or exercise. The Athenians appear for a long time only to have had private baths, but afterwards they had public ones: the latter seem to have originated among the Lacedæmonians, who invented the hot-air bath, at least the form of it called after them, the *Lavœicum*. Although the baths of the Greeks were not so luxurious as those of some other nations, yet effeminate people were accused among them of using warm baths in excess; and the bath servants appear to have been rogues and thieves, as

in later and larger establishments. The Persians must have had handsomely equipped baths, for Alexander the Great admired the luxury of the baths of Aleria.

But the baths of the Greeks, and probably of all Eastern nations, were on a small scale as compared with those which eventually sprung up among the Romans. In early times the Romans used after exercise to throw themselves into the Tiber. Next, when ample supplies of water were brought into the city, large *piscinæ*, or cold swimming baths, were constructed, the earliest of which appear to have been the *piscina publica* (312 B.C.), near the Circus Maximus, supplied by the Appian aqueduct, the *lavacræum* of Agrippina, and a bath at the end of the Clivus Capitolinus. Next, small public as well as private baths were built; and with the empire more luxurious forms of bathing were introduced, and warm became far more popular than cold baths.

Public baths or *balneæ* were first built in Rome after Clodius brought in the supply of water from Præneste. After that date baths began to be common both in Rome and in other Italian cities; and private baths, which gradually came into use, were attached to the villas of the wealthy citizens. Mæcenas was one of the first who built public baths at his own expense. After his time each emperor, as he wished to ingratiate himself with the people, lavished the revenues of the state in the construction of enormous buildings, which not only contained suites of bathing apartments, but included gymnasia, and sometimes even theatres and libraries. Such enormous establishments went by the name of *thermæ*. The principal *thermæ* were those of Agrippa 21 B.C., of Nero 65 A.D., of Titus 81, of Domitian 95, of Commodus 185, of Caracalla 217, and still later those of Diocletian 302, and of Constantine. The technical skill displayed by the Romans in rendering their walls and the sides of reservoirs impervious to moisture, in conveying and heating water, and in constructing flues for the conveyance of hot air through the walls, was of the highest order.

The Roman baths contained swimming baths, warm baths, baths of hot air, and vapour baths. The chief rooms (which in the largest baths appear to have been mostly distinct, whereas in smaller baths one chamber was made to do duty for more than a single purpose) were the following:—(1.) The *apodyterium* or *spoliatorium*, where the bathers undressed; (2.) the *alipterium* or *unctuarium*, where oils and ointments were kept (although the bathers often brought their own pomades), and where the *aliptæ* anointed the bathers; (3.) The *frigidarium* or cool room, *cella frigida*, in which usually was the cold bath, the *piscina* or *baptisterium*; (4.) The *tepidarium*, a room moderately heated, in which the bathers rested for a time, but which was not meant for bathing; (5.) The *calidarium* or heating room, over the *hypocaustum* or furnace; this in its commonest arrangement had at one end a warm bath, the *alveus* or *calida lavatio*; at the other end in a sort of alcove was (6.) The *sulatorium* or *laconicum*, which usually had a *labrum* or large vessel containing water, with which bathers sprinkled themselves to help in rubbing off the perspiration. In the largest baths the laconicum was probably a separate chamber, a circular domical room with recesses in the sides, and a large opening in the top; but there is no well-preserved specimen, unless that at Pisa may be so regarded. In the drawing of baths from the *thermæ* of Titus (fig. 1), the laconicum is represented as a small cupola rising in a corner of the calidarium. It is known that the temperature of the laconicum was regulated by drawing up or down a metallic plate or *clypeus*. Some think that this clypeus was directly over the flames of the hypocaustum, and that when it was withdrawn, the flames must have sprung into the laconicum. Others, and apparently they have Vitruvius on their side, think that the clypeus was

drawn up or down only from the aperture in the roof, and that it regulated the temperature simply by giving more or less free exit to the hot air. The question must for the present remain unsettled; if the laconicum was only one end of the calidarium, it is difficult to see how that end of the room was kept so much hotter than the rest of it; on the other hand to have had flames actually issuing from the laconicum, must have caused smoke and soot, and have been very unpleasant. The most usual order in which the rooms were employed seems to have been the following, but there does not appear to have been any absolute uniformity of practice then, any more than in modern Egyptian and Turkish baths. Celsus recommends the bather first to sweat a little in the tepidarium with his clothes on, to be anointed there, and then to pass into the calidarium; after he has sweated freely there he is not to descend into the solium or cold bath, but to have plenty of water poured over him from his head,—first warm, then tepid, and then cold water,—the water being poured longer over his head than on the rest of the body; next to be scraped with the strigil, and lastly to be rubbed and anointed.

The warmest of the heated rooms, *v. e.*, the calidarium and laconicum, were heated directly from the hypocaustum, over which they were built or suspended (*suspensura*); while from the hypocaustum tubes of brass, or lead, or pottery carried the hot air or vapour to the walls of the other rooms. The walls were usually hollow, so that the hot air could readily circulate.

The water was heated ingeniously. Close to the furnace, about 4 inches off, was placed the *calidarium*, the copper (*alveum*) for boiling water, near which, with the same interval between them, was the copper for warm water, the *tepidarium*, and at the distance of 2 feet from this was the receptacle for cold water, or the *frigidarium*, often a plastered reservoir. A constant communication was kept up between these vessels, so that as fast as hot water was drawn off from the calidarium a supply was obtained from the tepidarium, which, being already heated, but slightly reduced the temperature of the hotter boiler. The tepidarium, again, was supplied from the frigidarium, and that from an aqueduct. In this way the heat which was not taken up by the first boiler passed on to the second, and instead of being wasted, helped to heat the second—a principle which has only lately been introduced into modern furnaces. In the case of the large thermæ the water of an aqueduct was brought to the *castellum*, or top of the building, and was allowed to descend into chambers over the hypocaustum, where it was heated and transmitted in pipes to the central buildings. Remains of this arrangement are to be seen in the baths of Caracalla. The general plan of such buildings will be more clearly understood after an examination of the accompanying illustrations. In the

of the chamber named *concamerata sudatio*. The vessels for water are inscribed, according to their temperature, with the same names as some of the chambers, *frigidarium*, *tepidarium*, and *calidarium*.



FIG. 2.—Ground-Plan of the Baths of Pompeii.

The baths of Pompeii (as shown in fig. 2) were a double set, and were surrounded with *tabernæ* or shops, which are marked by a lighter shade. There were streets on four sides; and the reservoir supplying water was across the street in the building on the left hand of the cut. There were three public entrances—21a, 21b, 21c—to the men's baths and one to the women's. The furnaces (9) heated water, which was conveyed on one side to the larger baths of the men, on the other to the women's. Entering from the street at 21c there was a latrina on the left hand (22). From this it was usual to proceed to a court (20) surrounded by pillars, where servants were in attendance. There is some doubt as to the purpose to which the room (19) was devoted. Leaving the hall a passage conducted to the apodyterium or dressing-room (17), at one end of it is the frigidarium, baptisterium, or cold plunge bath (18). Entering out of the apodyterium is the tepidarium, or warming-room (15), which most probably was also used as the alipterium or anointing-room. From it bathers passed into the hot room or calidarium (12), which had at one end the *alveus* or *calida lavatio* (13), at the other end the *labrum* (14). This end of the calidarium served as the laconicum. The arrangements of the women's baths were similar, but on a smaller scale. The calidarium (5) had the *labrum* (7) at one end, and the *alveus* (6) was in one side of the room. The general arrangements of a calidarium are well illustrated by the accompanying section (fig. 3) of a bath discovered at

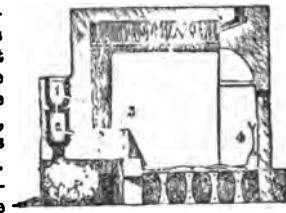

FIG. 3.—Section of Bath discovered at Tusculum, showing the calidarium (hot room).



FIG. 1.—Roman Baths.

well-known drawing (fig. 1) found in the baths of Titus, the name of each part of the building is inscribed on it. The small dome inscribed laconicum directly over the furnace, and having the clypeus over it, will be observed in the corner

Tusculum. The disposition of the parts is the same as at Pompeii. We here have the calidarium supported on the pillars of the *fofnax*, the *suspensura*. The *alveus* (3) is

at one end, and the labrum (4) at the other. (1) and (2) are the vessels for water over the fornax; and the passages in the roof and walls for the escape of heated air will be observed.

A clear idea of the relative position of the different rooms, and some slight indication of their ornamentation, will be obtained from the accompanying woodcut (fig. 4). The flues

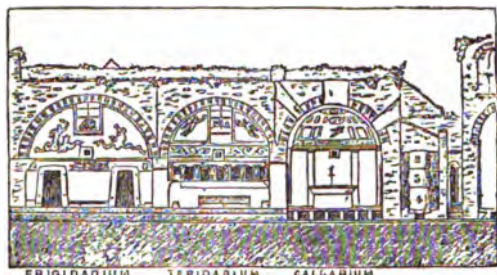

FIG. 4.—Section of Baths of Pompeii.

under the caldarium and the labrum (1) may be observed, as also the opening in the roof above. (2), (3), and (4) mark the vessels for water which are placed between the men's baths on the left and the women's on the right.

The arrangements of the *thermae* were mainly those of the balneæ on a larger scale. Some idea of their size may be gathered from such facts as these, that in the baths of Diocletian one room has been transmuted into a church of most imposing proportions, and that the outside walls of the baths of Caracalla extend about a quarter of a mile on each of the four sides. A visit to the remains of the baths of Titus, of Diocletian, or of Caracalla impresses the mind strongly with a sense of the vast scale on which they were erected, and Ammianus's designation of them as provinces appears scarcely exaggerated. It is said that the baths of Caracalla contained 1600, and those of Diocletian

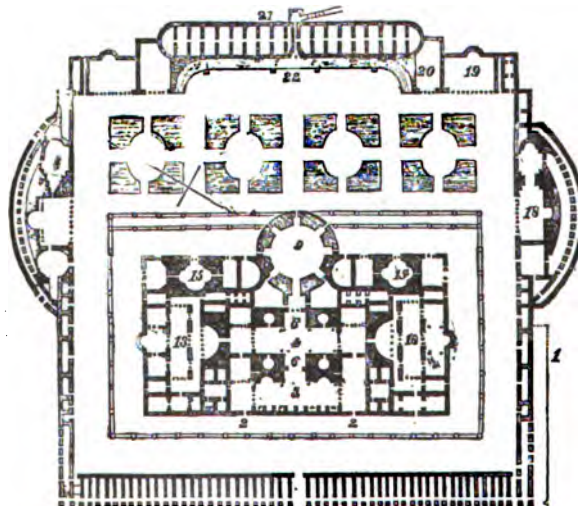

FIG. 5.—Ground-Plan of the Baths of Caracalla.

3200 marble seats for the use of the bathers. In the largest of the *thermae* there was a stadium for the games of the young men, with raised seats for the spectators. There were open colonnades and seats for philosophers and literary men to sit and discourse or read their productions aloud, or for others to discuss the latest news. Near the porticoes, in the interior open space, rows of trees were

planted. There was a *sphaeristerium*, or place for playing ball, which was often over the apodyterium; but it must be confessed that the purposes of many portions of these large edifices have not been made out in as satisfactory a way as those of smaller baths. A more definite idea of the *thermae* can be best got by an examination of the accompanying plan of the baths of Caracalla (fig. 5). A good deal of the plan is conjectural,—the restorations being marked by lighter shading.

At the bottom of the plan is shown a long colonnade, which faces the street, behind which was a series of chambers, supposed to have been separate bathing-rooms. Entering by the opening in its centre, the visitor passes what was probably an inner colonnade round the main building. Passing in by either of the gates (2, 3), he reaches the large chamber (8), which has been variously called the nativarium or large swimming bath, or the tepidarium. The great central room (4) in all probability was the caldarium, with two labra (6, 6) on opposite sides, and with four alvei, one in each corner, represented by small circular dots. (9) has been regarded by some as the laconicum, although it appears very large for that purpose. The rooms (15, 15) have been variously described as baptisteria and as laconica. Most authors are agreed in thinking that the large rooms (13) and (16) were the *sphaeristeria*, or places for playing ball.

Returning to the outside, (1) and (18) and the corresponding places on the other side, are supposed to have been the exedrae for philosophers, and places corresponding to the Greek *xystrai*. (20) and (19) have been considered to be servants' rooms. (22) was the stadium, with raised seats for the spectators. The space between this and the large central hall (9) was planted with trees, and at (21) the aqueduct brought water into the castellum or reservoir, which was on an upper story. There were upper stories in most portions of the building, and in these probably were the libraries and small theatres.

The magnificence of many of the *thermae* and their luxurious arrangements were such that some writers, as Seneca, are quite lost in their descriptions of them. The piscines were often of immense size,—that of Diocletian being 200 feet long,—and were adorned with beautiful marbles. The halls were crowded with magnificent columns, and were ornamented with the finest pieces of statuary. The walls, it has been said, were covered with exquisite mosaics that imitated the art of the painter in their elegance of design and variety of colour. The Egyptian syenite was encrusted with the precious green marbles of Numidia. The rooms contained the works of Phidias and Praxiteles. A perpetual stream of water was poured into capacious basins through the wide mouths of lions of bright and polished silver; water issued from silver, and was received on silver. "To such a pitch of luxury have we reached," says Seneca, "that we are dissatisfied if we do not tread on gems in our baths."

The richer Romans used every variety of oils and pomades (*mezymata*); they scarcely had true soaps. The poorer class had to be content with the flour of lentils, an article used at this day for the same purpose by Orientals. The most important bath utensil was the strigillus, a curved instrument made of metal, with which the skin was scraped and all sordes removed.

The bath servants assisted in anointing, in using the strigillus, and in various other menial offices. The poorer classes had to use their strigils themselves. The



FIG. 6.—Ring which are suspended some of the articles in use in the Alipiterium.

<sup>1</sup> The figure represents four strigils, in which the hollow for collecting the oil or perspiration from the body may be observed. There is also a small ampulla or vessel containing oil, meant to keep the strigils smooth, and a small flat patera or drinking vessel, out of which it was customary to drink after the bathing was finished.



various processes of the aliptas seem to have been carried on very systematically.

The hot baths appear to have been open from 1 P.M. till dark. It was only one of the later emperors that had them lighted up at night. When the hot baths were ready (for, doubtless, the plunge baths were available at an earlier hour), a bell or *cs* was rung for the information of the people. Among the Greeks and Romans the eighth hour, or 1 o'clock, before their dinner, was the commonest hour for bathing. The bath was supposed to promote appetite, and some voluptuaries had one or more baths after dinner, to enable them to begin eating again; but such excesses, as Juvenal tells us, occasionally proved fatal. Some of the most effeminate of the emperors are said to have bathed seven or eight times in the course of the day. In early times there was delicacy of feeling about the sexes bathing together; even a father could not bathe with his sons, but latterly, under most of the emperors, men and women often used the same baths. There frequently were separate baths for the women, as we see at Pompeii, or at Badenweiler; but although respectable matrons would not go to public baths, promiscuous bathing was common during the empire.

The public baths and *thermæ* were under the more immediate superintendence of the *ædiles*. The charge made at a public bath was only a quadrans or quarter of an as, about half a farthing. Yet cheap though this was, the emperors used to ingratiate themselves with the populace, by making the baths at times gratuitous.

Wherever the Romans settled, they built public baths; and wherever they found hot springs or natural stufa, they made use of them, thus saving the expense of heating, as at the *myrta* of Baia, or the *agua solis* of Bath. In the cities there appear to have been private baths for hire, as well as the public baths; and every rich citizen had a set of baths attached to his villa, the fullest account of which is given in the *Letters* of Pliny, or in Ausonius's *Account of a Villa on the Moselle*, or in Statius's *De Balneo Struoco*. Although the Romans never wholly gave up cold bathing, and that practice was revived under Augustus by Antoninus Musa, and again under Nero by Charmis (at which later time bathing in the open sea became common), yet they chiefly practised warm bathing (*calida lavatio*). This is the most luxurious kind of bathing, and when indulged to excess, is enervating. The women were particularly fond of these baths, and were accused, at all events in some provincial cities, of drunkenness in them.

The unbounded licence of the public baths, and their connection with modes of amusement that were condemned, led to their being to a considerable extent proscribed by the early Christians. The early fathers wrote that bathing might be practised for the sake of cleanliness or of health, but not of pleasure; and Gregory the Great saw no objection to baths being used on Sunday. About the 5th century many of the large *thermæ* in Rome fell into decay. The cutting off of the aqueducts by the Huns, and the gradual decrease of the population, contributed to this. Still it is doubtful whether bathing was ever disused to the extent that is usually represented. It was certainly kept up in the East in full vigour at Alexandria and at Brusa. Hot bathing, and especially hot air and vapour baths, were adopted by the Mahometans; and the Arabs brought them with them into Spain. The Turks, at a later time, carried them high up the Danube, and the Mahometans spread or, it may be more correct to say, revived their use in Persia and in Hindustan. The Crusaders also contributed to the spread of baths in Europe, and hot vapour baths were specially recommended for the leprosy so prevalent in those days. After the commencement of the 13th century there were few large cities in Europe without hot vapour baths.

We have full accounts of their regulations,—how the Jews were only allowed to visit them once a week, and how there were separate baths for lepers. In England they were called *hothouses*. Erasmus, at the date of the Reformation, spoke of them as common in France, Germany, and Belgium; he gives a lively account of the mixture of all classes of people to be found in them, and would imply that they were a common adjunct to inns. They seem after a time to have become less common, though Montaigne mentions them as being still in Rome in his day. In England the next revival of baths was at the close of the 17th century, under the Eastern name of *Hummuns*, or the Italian name of *Bagnios*. As these, like more recent revivals of them, were avowedly on the principle of the Turkish baths, that species of bath must be briefly noticed. But before doing so, we must observe that there were several considerable epochs in the history of baths, one in the commencement of the 18th century, when Floyer and others recalled attention to cold bathing, of which the virtues had long been overlooked. In the middle of the century also, Russell and others revived sea-bathing in England, and were followed by others on the Continent, until the value of sea-bathing became fully appreciated. Later in the same century the experiments of Currie on the action of complete or of partial baths on the system in disease attracted attention; and though forgotten for a while, they have borne abundant fruit in more recent times.

*Modern Baths*.—It is uncertain how far the Turkish and Egyptian and even the Russian baths are to be regarded merely as successors of the Roman baths, because the principle of vapour baths has been known to many nations in a very early period of civilization. Thus the Mexicans and Indians were found using small vapour baths. The ancient inhabitants of Ireland and of Scotland had some notion of their use, and the large vapour baths of Japan, now so extensively employed, are probably of independent origin. We extract at some length accounts of Turkish and of Russian baths, as they illustrate the practices of the ancient Roman and of modern Turkish baths. The first is taken from Lane's work *On the Modern Egyptians*:—"The building consists of several apartments, all of which are paved with marble, chiefly white. The inner apartments are covered with domes, which have a number of small glazed apertures for the admission of light. The bather, on entering, if he has a watch or purse, gives them in charge to the keeper of the bath. The servant of the bath takes off his shoes, and supplies him with a pair of wooden clogs. The first apartment has generally three or four *leewans* (raised parts of the floor used as couches) cased with marble, and a fountain of cold water, which rises from an octagonal basement in the centre. One of the *leewans*, which is meant for the higher classes, is furnished with cushions or mats.

"In warm weather bathers usually undress in this room; in winter they undress in an inner room, called the *bey-towwal*, or first chamber, between which and the last apartment there is a passage often with two or three latrines off it. This is the first of the heated chambers. It generally has two raised seats. The bather receives a napkin in which to put his clothes, and another to put round his waist; this reaches to the knees, a third, if he requires it, is brought him to wind round his head, leaving the top of it bare; a fourth to put over his chest, and a fifth to cover his back. When the bather has undressed, the attendant opens to him the door of the inner and principal apartment. This in general has four *leewans*, which gives it the form of a cross, and in the centre a fountain of hot water rises from a small shallow basin. The centre room, with the adjoining ones, forms almost a square. The *beytowwal*

already mentioned is one of them. Two small chambers which adjoin each other, one containing a tank of hot water, the other containing a trough, over which are two taps, one of hot and one of cold water, occupy the two other angles; while the fourth angle of the square is occupied by the chamber which contains the fire, over which is the boiler.

"The bather having entered this apartment soon perspires profusely from the humid heat which is produced by the hot water of tanks and fountains, and by the steam of the boiler. The bather sits on one of the marble seats, or lies on the leewan, or near one of the tanks, and the operator then commences his work. The operator first cracks aloud every joint in the body. He makes the vertebrae of the back and even of the neck crack. The limbs are twisted with apparent violence, but so skilfully, that no harm is ever done. The operator next kneads the patient's flesh. After this he rubs the soles of the feet with a kind of rasp of baked clay. There are two kinds of rasps, one porous and rough, one of fine smooth clay. Those used by ladies are usually encased in thin embossed silver. The next operation is rubbing the bather's flesh with a small coarse woollen bag, after which the bather dips himself in one of the tanks. He is next taken to one of the chambers in the corner, and the operator lathers the bather with fibres of the palm tree, soap and water. The soap is then washed off with water, when the bather having finished washing, and enveloped himself in dry towels, returns to the beytowaal and reclines. Here he generally remains an hour to an hour and a half, sipping coffee and smoking, while an attendant rubs the soles of the feet and kneads the body and limbs. The bather then dresses and goes out."

The following description of a Russian bath is from Kohl's *Russia*.—"The passage from the door is divided into two behind the check-taker's post, one for the male, one for the female guests. We first enter an open space, in which a set of men are sitting in a state of nudity on benches, those who have already bathed dressing, while those who are going to undergo the process take off their clothes. Round this space or apartment are the doors leading to the vapour-rooms. The bather is ushered into them, and finds himself in a room full of vapour, which is surrounded by a wooden platform rising in steps to near the roof of the room. The bather is made to lie down on one of the lower benches, and gradually to ascend to the higher and hotter ones. The first sensation on entering the room amounts almost to a feeling of suffocation. After you have been subjected for some time to a temperature which may rise to 145°, the transpiration reaches its full activity, and the sensation is very pleasant. The bath attendants come and flog you with birchen twigs, cover you with the lather of soap, afterwards rub it off, and then hold you over a jet of ice cold water. The shock is great, but is followed by a pleasant feeling of great comfort and of alleviation of any rheumatic pains you may have had. In regular establishments you go after this and lie down on a bed for a time before issuing forth. But the Russians often dress in the open air, and instead of using the jet of cold water, go and roll themselves at once in the snow."

Turkish baths have, with various modifications, become popular in Europe. The Russian baths were introduced into most German towns about half a century ago. They had a certain limited amount of popularity, but did not take firm root. Another class practically owes its origin to Dr Barter and Mr Urquhart. It professed to be founded on the Turkish bath, but in reality it was much more of a hot air bath, i.e., more devoid of vapour than either Roman or Turkish baths ever were, for it is doubtful whether in any case the air of the lacouicum was free from vapour.

These baths, with their various modifications, have become extremely popular in Great Britain, in Germany, and in Northern Europe, but have, curiously enough, never been used extensively in France, notwithstanding the familiarity of the French with Turkish baths in Algiers.

In England hot air baths are now employed very extensively. They are often associated with Turkish and electric baths, and with the usual processes of hydropathic treatment.

Bathing among the ancients was practised in various forms. It was sometimes a simple bath in cold or in tepid water; but at least, in the case of the higher orders, it usually included a hot air or vapour bath, and was followed by affusion of cold or warm water, and generally by a plunge into the piscina. In like manner the order varies in which the different processes are gone through in Turkish baths in modern Europe. Thus in the new baths in Vienna, the process begins by immersion in a large basin of warm water. Sudation is repeatedly interrupted by cold douches at the will of the bathers, and after the bath they are satisfied with a short stay in the cooling-room, where they have only a simple sheet rolled round them. In Copenhagen and in Stockholm the Oriental baths have been considerably modified by their association with hydropathic practices.

This leads us to notice the introduction of hydropathy. Although cold baths were in vogue for a time in Rome, warm baths were always more popular. Floyer, as we have seen, did something to revive their use in England; but it was nearly a century and a half afterwards that a Silesian peasant, Priessnitz, introduced, with wonderful success, a variety of operations with cold water, the most important of which was the packing the patient in a wet sheet, a process which after a time is followed by profuse sudation. Large establishments for carrying out this mode of bathing and its modifications have within the last thirty years been erected in many places on the Continent and in Great Britain and have enjoyed a large share of popularity.

But the greatest and most important development of ordinary baths in modern times has taken place in England, and has been extending gradually to the Continent. The English had long used affusion and swimming baths freely in India. Cold and hot baths and shower baths have been introduced into private houses to an extent never known before; and, from 1842 downwards, public swimming baths, besides separate baths, have been supplied to the public at very moderate rates, in some cases associated with wash-houses for the poorer classes. Their number has increased rapidly in London, and in the principal Continental cities. Floating baths in rivers, always known in some German towns, have become common wherever there are flowing streams. The better supply of most European cities with water has aided in this movement. Ample enclosed swimming baths have of late years been erected at many sea-side places. When required, the water, if not heated in a boiler, is raised to a sufficient temperature by the aid of hot water pipes or of steam; and gas has been utilized for heating small quantities of water for baths in private houses. As to separate baths they used to be of wood, painted; they are now most frequently of metal, painted or lined with porcelain enamel. The swimming baths are lined with cement, tiles, or marble and porcelain slabs; and in some of the newest baths a good deal of ornamentation and painting of the walls and ceiling of the apartments, in imitation of the ancients, has been attempted.

We have thus traced in outline the history of baths through successive ages down to the present time. The medium of the baths spoken of thus far has been water, vapour, or dry hot air. But baths of more complex

nature, and of the greatest variety, have been in use from the earliest ages. The best known media are the various mineral waters and sea-water. These, and baths impregnated with their gases, cannot here be considered in detail; we can do little more than enumerate a few of the artificial baths. Of baths of *mineral* substances, those of sand are the oldest and best known; the practice of *arenation* or of burying the body in the sand of the seashore, or in heated sand near some hot spring, is very ancient, as also that of applying heated sand to various parts of the body. Within the last few years establishments have been introduced into various European cities where hot dry sand is methodically applied. Baths of *peat* earth are of comparatively recent origin, and are little used out of Germany. The peat earth is carefully prepared and pulverized, and then worked up with water into a pasty consistence, of which the temperature can be regulated before the patient immerses himself in it.

There are various baths that may be termed *chemical*, in which chlorine or nitromuriatic acid is added to the water of the bath, or where fumes of sulphur are made to rise and envelop the body.

Of *vegetable* baths the number is very large. Leys of wine, in a state of fermentation, have been employed. An immense variety of aromatic herbs have been used to impregnate water with. Of late years fuci or sea-weed have been added to baths, under the idea of conveying into the system the iodine which they contain; but by far the most popular of all vegetable baths are those made with an extract got by distilling certain varieties of pine leaves. They are pleasant and stimulating.

The strangeness of the baths of *animal* substances, that have been at various times in use, is such that their employment seems scarcely credible. That baths of milk or of whey might be not unpopular is not surprising, but baths of blood, in some cases even of human blood, have been used; and baths of horse dung were for many ages in high favour, and were even succeeded for a short time by baths of guano.

*Electrical* or *galvanic* baths have been popular of late years, in which galvanic action is communicated to the patient while in baths.

Baths also of *compressed air*, in which the patient is subjected to the pressure of two or three atmospheres, have been in use at certain places for some years.

A *sun* bath (*insolatio* or *heliosis*), exposing the body to the sun, the head being covered, was a favourite practice among the Greeks and Romans. This list of artificial baths might be readily increased.

We have hitherto spoken of general baths, but there are many varieties of local ones, the use of which has become somewhat more definite than it used to be, before the principles of hydropathy were understood. Some of these are affusion, half-baths, full baths, sitz baths, wave baths, local baths, shower and spray baths, douches, fomentations, injections, wrapping up in the wet sheet. Some of these processes, though by no means of novel origin, require a few words of explanation.

*Douches* were used by the ancients, and have always been an important mode of applying water to a circumscribed portion of the body. They are, in fact, spouts of water, varying in size and temperature, applied with more or less force for a longer or shorter time against particular parts. A douche exercises a certain amount of friction, and a continued impulse on the spot to which it is applied, which stimulate the skin and the parts beneath it, quicken the circulation of the capillaries, and thus favour the absorption of abnormal deposits. It wakes up the slumbering activity of the tissues and helps to remove congestions from the deeper seated organs. The

effects of the douche are so powerful that it cannot be applied for a long time continuously. After every two or three minutes there should be an interval in its use. It is obvious that a douche is capable of many local applications, on the description of which it is here impossible to enter. Nor need we say that the douche must be used with great care in the case of nervous and excitable people, and better not at all when any irritation or inflammation is present. Douches are invaluable in old neuralgias, in the sequelae of rheumatism, and in thickened joints.

The alternation of hot and cold douches, which for some unknown reason has got the name of *Scossaise*, is a very powerful remedy from the strong action and reaction which it produces, and is one of very great value. The shower bath may be regarded as a union of an immense number of fine douches projected on the head and shoulders. It has been long in use in England, and produces a strong effect on the nervous system. An ingenious contrivance for giving circular spray baths, by which water is propelled laterally in fine streams against every portion of the surface of the body, is now found in most establishments.

To all these modes of acting on the cutaneous surface and circulation must be added dry rubbing, as practised by the patient with the flesh glove, but much more thoroughly by the bath attendants, if properly instructed.

*Action of Baths on the Human System.*—We shall now inquire shortly into the theory of the operation of the baths and of the bathing processes, of which we have briefly traced the history.

The primary operation of baths is the action of heat and cold on the cutaneous surfaces through the medium of water.

The first purpose of baths is simply that of absterision and cleanliness, to remove any foreign impurity from the surface, and to prevent the pores from being clogged by their own secretions or by desquamations of cuticle. It need scarcely be said that such objects are greatly promoted by the action of the alkali of soaps and by friction; that the use of warm water, owing to its immediate stimulation of the skin, promotes the separation of scales; and that the vapour of water is still more efficient than water itself.

It has been supposed that water acts on the system by being absorbed through the skin. The question has been frequently discussed; but the great majority of observers believe that, under ordinary circumstances, no water is absorbed, or if any, so minute a quantity that it is not worth considering. And further, as we have alluded to medicated baths, it is proper to say that, according to the latest authorities, no foreign bodies, under the ordinary circumstances of a bath, are absorbed into the system; although when a portion of skin has been entirely cleared of its sebaceous secretion, it is possible that a strong solution of salts may be partially absorbed. In the case of medicated baths we therefore only look (in addition to the action of heat and cold, or more properly to the abstraction or communication and retention of heat) to any stimulant action on the skin which the ingredients of the bath may possess.

The powerful influence of water on the capillaries of the skin, and the mode and extent of that operation, depend primarily on the temperature of the fluid; for the influence of the mechanical pressure on the body of the water of a bath, which has been calculated at nearly one pound on each square inch of the surface, has never been accurately determined. Baths have therefore to be considered according to their temperature; and the effects of cold and of hot baths have to be studied. But we may as well first point out one or two general facts. The human system bears changes of temperature of the air much better than changes of the temperature of water. While the temperature of the

air at 75° is perhaps too warm for the feelings of many people, a continued bath at that temperature is felt to be cold and depressing. Again, a bath of 98° to 102° acts far more excitingly than air of the same temperature, both because, being a better conductor, water brings more heat to the body, and because it suppresses the perspiration, which is greatly augmented by air of that temperature. Further, a temperature a few degrees below blood heat is that of indifferent baths, which can be borne longest without natural disturbance of the system.

*Cold baths* act by refrigeration, and their effects vary according to the degree of temperature. The effects of a cold bath, the temperature not being below 50°, are these:—there is a diminution of the temperature of the skin and of the subjacent tissues; the blood at first rises in temperature nearly 4°, but soon subsides again, this diminution of temperature of the blood usually not taking place in the bath, but shortly after leaving it. There is a certain feeling of shock diffused over the whole surface, and if the cold is intense it induces a slight feeling of numbness in the skin. It becomes pale and its capillaries contract. The further action of a cold bath reaches the central nervous system, the heart and the lungs, as manifested by the tremor of the limbs it produces, along with a certain degree of oppression of the chest and a gasping for air, while the pulse becomes small and sinks. After a time reaction takes place, and brings redness to the skin and an increase of temperature.

The colder the water is, and the more powerful and depressing its effects, the quicker and more active is the reaction. Very cold baths, anything below 50°, cannot be borne long. Lowering of the temperature of the skin may be borne down to 9°, but a further reduction may prove fatal. The diminution of temperature is much more rapid when the water is in motion, or when the bather moves about; because, if the water is still, the layer of it in immediate contact with the body gets warmed to a certain degree.

The effects of *hydropathy* depend on the power of abstracting heat from the body, and of stimulating it by the application of cold water. The action is depressing or exciting, according as the withdrawal of heat or the stimulation predominates.

A great deal depends on the form of the bath; thus one may have—(1.) Its depressing operation,—with a loss of heat, retardation of the circulation, and feeling of weariness, when the same water remains in contact with the skin, and there is continuous withdrawal of heat without fresh stimulation. This occurs with full or sits baths, with partial or complete wrapping up the body in a wet sheet which remains unchanged, and with frictions practised without removing the wet sheets. (2.) Its exciting operation,—with quickening of the action of the heart and lungs, and feeling of glow and of nervous excitement and of increased muscular power. These sensations are produced when the layer of water next the body and heated by it is removed, and fresh cold water causes fresh stimulus. These effects are produced by full baths with the water in motion used only for a short time, by frictions when the wet sheet is removed from the body, by douches, shower baths, bathing in rivers, &c. The depressing operation comes on much earlier in very cold water than in warmer; and in the same way the exciting operation comes on faster with the colder than with the warmer water. The short duration of the bath makes both its depressing and its exciting action less; its longer duration increases them; and if the baths be continued too long, the protracted abstraction of animal heat may prove very depressing.

We shall not attempt to give more than those few hints about hydropathic processes, and shall merely remark that, under them the system is subjected to alternate periods of

excitement and of rest. There is persistent lowering of the temperature of the body, with contraction of the capillaries and local anæmia. This is succeeded by the reverse, or by local hyperæmia. There is powerful excitement of the vascular and nervous systems. The processes of absorption and of excretion are stimulated. There is a great increase of perspiration. The transformation of tissue is materially quickened.

We must next consider the operation of warm baths of different temperatures.

*Temid*, 85° to 95°.—The effects of a bath of this temperature are confined to the peripheral extremities of the nerves, and are so slight that they do not reach the central system. There is no reaction, and the animal temperature remains unchanged. Baths of this kind can be borne for hours with impunity.

*Warm baths from 96° to 104°*.—In these the action of the heat on the peripheral surface is propagated to the central system, and causes reaction, which manifests itself in moderately increased flow of the circulating fluids to the surface, and in an increased frequency of pulse. It appears to supply a slight stimulus to the renewal of tissue.

With a *hot bath* from 102° up to 110° the central nervous and circulating systems are more affected. The frequency of the pulse increases rapidly, the respiration becomes quickened, and is interrupted by deep inspirations. The skin is congested, and the retained animal heat bursts out, causing a profuse perspiration.

*Very hot bath*.—Everything above 110° feels very hot; anything above 120° almost scalding. Baths of from 119° to 126° have caused a rise of 2° to 4½° in the temperature of the blood. Such a bath can only be borne for a few minutes. It causes violent reflex action on the heart and the arterial system, excessive congestion of the skin, and violent perspiration.

In the use of hot baths a certain amount of vapour reaches the parts of the body not covered by the water, and is also inhaled.

*Vapour* baths produce profuse perspiration, and act in cleansing the skin, as powerful hot water baths do. Vapour, owing to its smaller specific heat, does not act so fast as water on the body. A vapour bath can be borne for a much longer time when the vapour is not inhaled. Vapour baths can be borne hotter than water baths, but cannot be continued so long, as vapour, being a bad conductor, prevents radiation of heat from the body. A higher heat than 122° is not borne comfortably. The vapour bath, though falling considerably short of the temperature of the hot air bath, heats the blood considerably more.

*Hot air* baths differ from vapour baths in not impeding the respiration as the latter do, by depositing moisture in the bronchial tubes. The lungs, instead of having to heat the inspired air, are subjected to a temperature above their own. Hot air baths, say of 135°, produce more profuse perspiration than vapour baths. If very hot, they raise the temperature of the body by several degrees.

Vapour baths, hot air baths, and many hydropathic processes agree in producing violent sudation, and also frequently in subjecting the body, while in a state of perspiration, to the action of water of a comparatively low temperature. Of perspiration we shall only say, that it is sensible and insensible: 30 oz. may be considered to be about its average amount in the twenty-four hours; of this, which is chiefly water, about ½ of an oz. consists of urea and of other peculiar substances. A man has been known to lose 3 lb in a Russian bath; some think more may be lost. As perspiration eliminates water and effete matter from the system, and also aids in respiration, it is obvious that its regulation must have an important effect on the economy.

In comparing the general effects of hot and cold baths, it

may be said that while the former tend to check cutaneous transpiration, the latter favour it. It is supposed, but is scarcely proved, that cold baths, by the stimulus they give, increase the reaction of the gastric and other fluids of the stomach, and of the alimentary canal, and that warm baths rather serve to retard it. Either hot or cold baths, but especially the latter, favour the secretion of urine. Whether warm or cold baths, like the breathing of hot or cold air, have any effect on the exhalation of carbonic acid has not been determined.

The warm bath causes swelling and congestion of the capillaries of the surface in the first instance; when the stimulus of heat is withdrawn their contraction ensues. A cold bath, again, first causes a contraction of the capillaries of the surface, which is followed by their expansion when reaction sets in. A warm bath elevates the temperature of the body, both by bringing a supply of heat to it and by preventing the radiation of heat from it. It can be borne longer than a cold bath. It draws blood to the surface, while a cold bath favours internal congestions. There is in both cases increased oxidation or waste of the tissues; but with the warm bath there is less call made on the system, as oxidation depends chiefly on increased heat, which in the case of the warm baths is artificially supplied. The reason why a man when much exhausted feels a hot bath refreshing, while he cannot bear a cold one, may be that the increased heat conveyed to him by the warm bath helps the process of oxidation, and thus relieves his system. Cold refreshes by exciting the functions, heat by physically relieving their action, a hot bath calms by reducing the loss of heat, and by supplying a certain amount of it. Very hot baths, it is true, act like cold baths, as stimulants to the heart and nervous centres; but they do it more gradually and with less shock to the system than cold baths. The general result of this comparison would show that warm are a milder remedy than cold baths, and are applicable often when the system does not possess power of reaction sufficient to make the use of the latter expedient.

As regards the use of baths simply for the promotion of health, it follows, from what has been stated, that warm baths are best suited for the delicate, for the very young, and for the old; cold baths for the strong and active, in whom the powers of reaction are unimpaired. It would be out of place to say much here about the use of baths in medicine. Warm baths according to their degree of heat are of great value in relaxing spasms, in calming the nervous system, and in neuralgias, chronic rheumatism, and gout. Turkish baths are useful in these last affections, and wherever it is of importance that there should be free action of the skin. Cold baths, again, are more useful when the system requires tonics, and when it can bear the shock of cold affusion; when diseases of the system, especially of the nervous system, are more functional than organic. It is obvious that the cold-water cure including, as it does, copious sudation, combines in a certain degree the effects of both kinds of baths.

But baths often produce injurious effects when used injudiciously. Long continued warm baths are soporific, and have owing to this action often caused death by drowning. The effects of very hot baths are swimming in the head, vomiting, fainting, congestion of the brain, and, in some instances, apoplexy.

The symptoms seem to point to paralysis of the action of the heart. It is therefore very evident how cautious those should be, in the use of hot baths, who have weak hearts or any obstruction to the circulation. Fat men, and those who are full-blooded or predisposed to epilepsy, should avoid them. Protracted indulgence in warm baths is relaxing, and has been esteemed a sign of effeminacy in all ages. Sleepiness, though it will not follow the first immersion in

a cold bath, is one of the effects of protracted cold baths; depression of the temperature of the surface that exceeds 9° becomes dangerous. The risk in cold baths is congestion of the internal organs, as often indicated by the lips getting blue. Extremely cold baths are, therefore, very unsafe wherever there is a tendency to internal congestion; and they are always dangerous, when the system is exhausted by fatigue.

We shall conclude with a few words of advice about ordinary bathing for hygienic purposes:—Wherever it is practicable, bathing should be over before 1 p.m. It is not to be thought of when the stomach is loaded, or after much wine. The shorter the bath is, especially if the water be cold, and the bather cannot swim, the better,—say five minutes. He should swim if possible, and then a quarter of an hour is long enough. Bathing should not be practised more than once a day. When one is over-heated, but not exhausted, it is advisable to bathe at once, without waiting to cool. After hot air or vapour baths care must be taken that cold be not caught, although the more enthusiastic advocates of such baths declare that there is no risk of this.

For the literature of baths in earlier periods we would refer to the *Architecture of Vitruvius*, and to Lucian's *Hippias*; to A. Baccius, *De Theriis Veterum* (in *Grovel's Thesaur. Antiquit. Roman.*, 1698, vol. xii.); to Cameron's *Roman Baths*, London, 1772; to Gell's *Pompeiana*, London, 1886; to Bechi, *Museo Borbonico*, ii. 49-52; to Becker's *Gallus*, and to the article "Balnea" by Rich, in *Dr Smith's Dictionary of Greek and Roman Antiquities*. Some of the more important works on the use of water externally are those of Floyer, *Enquiry into the Right Use of Water*, London, 1697; E. Hoffman, *De Aqua Medicina Universali*, Halle, 1712; Lucas, *Theory and Use of Baths*, Dublin, 1772; James Currie, *Medical Reports on the Effects of Water*, Liverpool, 1788; Marcard, *Ueber die Natur und die Gebrauch der Bäder*, Hanover, 1798. Some of the best works on Hydropathy are those of E. Johnson and Petri, and the very complete *Manuale of Fleury and of Beal Bards*. There are many separate brochures on Turkish baths by Urquhart, Brexton, Haughton, Barter, Bartholomew, Luther, and a separate work by Sir John Fife. A considerable amount of information regarding bathing may also be found in *Dunlop's Philosophy of the Bath*. (J. M.)

**BATHURST**, a town of New South Wales, on the Macquarie River, 122 miles W.S.W. of Sydney, with which it is connected by railway. It stands in a fertile plain on the western side of the Blue Mountains, and is the centre of an important gold field. Founded in 1815 by Governor Macquarie, and named in honour of Lord Bathurst (the third earl), it soon became a place of considerable size, and was raised to the rank of a municipality in 1862. It is built in rather a spacious style, with broad and regular streets running at right angles. Many of the buildings are large and handsome; and it possesses numerous churches and schools, a theatre, a hospital, and various societies. Population in 1871, 5030.

**BATHURST, ALLEN BATHURST, EARL OF**, a distinguished statesman in Queen Anne's reign, was born in the year 1684. After completing his education at Cambridge, he was elected in 1705 to represent the borough of Cirencester. He distinguished himself particularly in the struggles and debates relative to the union of England and Scotland, firmly supporting a measure which he thought calculated to strengthen the Government and add to the prosperity of the country. Though he was content to act a subordinate part in the opposition planned by Harley and St John, his intimate friends, in order to sap the credit of the duke of Marlborough and his adherents, nevertheless he did good service to his party by arraigning, with more eloquence than truth, the conduct of the general and of the earl of Godolphin, whom he accused of lavishing the treasures of the nation on conquests more splendid than serviceable. The loss of the battle of Almanza, which happened about this time, seconded his efforts and those of his associates in dispelling what they called the intoxication of former successes, and disparaging achievements which

reflect immortal honour on the British name. But his personal regard for Lord Somers, president of the council, suffered no abatement, although they were of different opinions in politics; and when Somers was deprived of office, Bathurst acted with such tenderness and delicacy as to preserve his esteem in a private station. In consideration of his zeal and services, the queen, in 1711, advanced him to the peerage by the title of Baron Bathurst, of Battlesden, in Bedfordshire. In the Upper House he distinguished himself by impeaching the directors of the notorious South Sea scheme, and by resisting the bill brought in against Atterbury. He was a determined opponent of Sir Robert Walpole; and when, after an obstinate struggle, that minister was forced to resign his various posts, Lord Bathurst was sworn of the privy council, and made captain of the gentlemen pensioners, an office which he resigned in 1744. In 1757 he was appointed treasurer to George III (then Prince of Wales), and continued in the list of privy councillors at that monarch's accession to the throne; but, on account of his advanced age, he declined to take any further part in politics.

Lord Bathurst was not less distinguished as a patron of literature than as an active statesman. Congreve, Vanburgh, Swift, Prior, Rowe, Addison, Pope, Arbuthnot, Gay, and most of the men of genius of his own time, cultivated his friendship, and were proud of his correspondence. Pope, in his *Epistle on the Use of Riches*, which is addressed to Lord Bathurst, compliments his friend in some highly characteristic lines. Sterne also speaks of him in terms of affectionate admiration. He received further elevation to an earldom in 1772, and lived to see his second son Henry promoted to the peerage by the title of Baron Apsley, and several years lord high chancellor of Great Britain. By his marriage with Catherine, daughter of Sir Peter Apsley, Lord Bathurst had four sons and five daughters. He died after a few days' illness, at his seat near Cirencester, September 16, 1775, in the ninety-first year of his age.

**BATHURST, RALPH**, uncle of the preceding, was born in the year 1620. He studied divinity in Trinity College, Oxford; but, on the breaking out of the civil war, he changed the course of his studies, and, applying himself to medicine, took the degree of doctor in that faculty. By dint of assiduous application, he soon rose to eminence in his profession; and in the time of the Commonwealth was appointed physician to the state. At the Restoration, however, he quitted the practice of physic; was elected a fellow of the Royal Society, and president of his college; and, having entered holy orders, was made chaplain to the king, and afterwards dean of Wells. Soon after, he filled the office of vice-chancellor of Oxford, and was nominated by King William and Queen Mary to the see of Bristol; but this honour he declined. To the accomplishments of an orator, philosopher, and poet, he added an inexhaustible fund of wit. Ridicule—of which he was an absolute master—was the weapon with which he used to correct the delinquents of his college. His poetical pieces in the *Musa Anglicana* are excellent of their kind; he wrote also several other poems, both in English and Latin. He died June 14, 1704, in his eighty-fourth year. (*Life and Remains*, by Th. Warton, 1761.)

**BATHYCLES**, a Greek sculptor, born at Magnesia on the Meander, known for his sculptures on the throne of the statue of Apollo at Amyclæ near Sparta, which Pausanias saw and describes (iii. 18, 6). His date is uncertain, but cannot well be later than between 563-549 B.C. The statue itself existed before his time. For an attempt to reconstruct this throne see Brunn, *Rhein. Museum* (new series), vol. v. p. 325.

**BATON-ROUGE**, a town in the state of Louisiana, North America, situated on a bluff on the left bank of the

Mississippi, 120 miles above New Orleans. It has a court house, state penitentiary, national arsenal and barracks, military hospital, deaf and dumb asylum, and state university. Baton-Rouge was one of the first settlements of the French. In 1849 it was made the capital of the state, but has since given place to New Orleans. Occupied by the Federal troops after the capture of that city, it was defended in 1862 by General Williams against the attack of the Confederates under Breckenridge. Population in 1870, 6495.

**BATONI, POMPEO GIROLAMO**, a native of Lucca, who was regarded in Italy as a great painter in the 18th century, and who unquestionably did much to rescue the art from the intense mannerism into which it had fallen during the century preceding. His paintings, however, are not of the highest order of merit, though they are generally graceful, well designed, and harmoniously coloured. His best production is thought to be his group of Peace and War. Batoni painted an unusual number of pictures, and was also celebrated for his portraits. He was born in 1708, and died at Rome in 1787.

**BATRACHIA**. See **ΑΜΦΙΒΙΑ**, vol. i. p. 750.

**BATRACHUS**, according to Pliny (xxxvi. 43), the name of a Greek architect who, along with Sauras (both natives of Sparta), was employed by Metellus in the construction of certain temples in Rome. The story goes that, being forbidden to inscribe their names on the buildings, these two architects gained their end by placing the figures of a frog (*batrachos*) and a lizard (*sauras*) on the base of the columns. But it is possible that the fanciful use of such figures for ornament in later times may have led to the invention of both the names.

**BATTALION** is the tactical unit of infantry. It is the term applied to the most numerous body of dismounted men which one commanding officer can personally superintend. It consists of from four to ten companies, is always commanded by a field officer, and has a normal war strength of about 1000 men. Two or more battalions constitute a regiment; two or more regiments a brigade; two or more brigades a division; two or more divisions a *corps d'armes*; and two or more *corps d'armés* an army. In the British service, however, there are several regiments consisting of but one battalion. See **ARMY**.

**BATTAS**, a people in the northern portion of Sumatra, which regards itself as the oldest in the island, and is distinguished by a pertinacious adherence to ancient customs. The Batta is of middle height, his colour is a light brown, and his hair is black and is worn long. He is dirty in his dress and dwelling, and eats any kind of food that presents itself, though he lives chiefly on rice. A little iron-work, earthenware, and cloth constitute the only industrial products of the tribe. The houses are of wood, roofed with palm-leaf ribs; and the villages are defended by earthen walls and bamboo palisades. The people show a very peaceful disposition, but are valorous when occasion demands. Cannibalism is practised.

*Batta or Batak Language*.—Up to the publication of Dr H. N. van der Tuuk's essay *Over schrift en uitspraak der Tobasche taal* (1855), the first fruits of an eight years' residence amongst the Battas, our knowledge of the Batak language was confined to lists of words more or less complete, chiefly to be found in Marsden's *Miscellaneous Works*, in Junghuhn's *Batavilunder*, and in the *Tijdschrift van het Bataviaasch Genootschap*, vol. iii. (1855). By his exhaustive works (*Batavisch Lessboek*, in 4 vols., 1861-2; *Batavisch-nederduitsch Woordenboek*, 1861; *Tobasche Spraak-kunst*, 1864-7) that eminent Dutch savant has made the Batak language the most accessible of the various tongues spoken in Sumatra. According to him, the Batak language is nearest akin to the Old Javanese and Tagal, whereas a recent writer (A. Schreiber, *Die Battas in ihrem Verhältnis*

*ou des Malaien von Sumatra*, 1874) has endeavoured to prove its closer affinity with the Malay proper. Like most languages spoken by less civilized tribes, the Batak is poor in general terms, but abounds in terms for special objects. The number of dialects is three, viz, the Toba, the Mandailing, and the Dairi dialects; the first and second have again two subdivisions each. The Bataks further possess six peculiar or recondite modes of speech, such as the *kata andung*, or language of the wakes, and the *kata poda*, or the soothsayer's language. A fair acquaintance with reading and writing is very general among them. Their alphabet is said, with the Rejang and Lampong alphabets, to be of Indian origin. The language is written on bark or bamboo staves from bottom to top, the lines being arranged from left to right. The Batak literature consists chiefly in books on witchcraft, in stories, riddles, incantations, &c., and is mostly in prose, occasionally varied by verse. See on it the fourth volume of the *Batak Lesebok*, or *Reader*, above mentioned.

**BATTERING RAM** (*Aries*), a military engine used before the invention of gunpowder, for beating down the walls of besieged fortresses. It consisted of a long heavy beam of timber, armed at the extremity with iron fashioned something like the head of a ram. In its simplest form the beam was carried in the hands of the soliders, who assailed the walls with it by main force. The improved ram was composed of a longer beam, in some cases extending to 120 feet, shod with iron at one end, and suspended, either by the middle or from two points, from another beam laid across two posts. This is the kind described by Josephus as having been used at the siege of Jerusalem (*B. J.*, iii. 7. 19). It was covered over with a roof, shell, or screen of boards (called the *testudo*) to protect the men employed in working it from the stones, darts, and other missiles discharged by the besieged from the walls. It was also provided with wheels, which greatly facilitated its operations. A hundred soldiers at a time, and sometimes even a greater number, were employed to work it, and the parties were relieved in constant succession. Josephus says that no wall could resist the continued application of the ram.

**BATTERY** is the tactical unit of artillery. It is the term applied to the largest number of fully equipped mobile guns which can be personally superintended by one man. Batteries may be divided into the four classes of *horse*, *field*, *mountain*, and *position* artillery batteries. In England, France, and Germany batteries consist of six guns; in Austria and Russia of eight guns each. The guns of horse field artillery are drawn by from four to eight horses, the usual number being six. Each battery has a certain number of men told off for the service of the gun called *gunners*, and others to manage the draught called *drivers*. In the horse artillery the gunners are mounted on horses, in field batteries they are carried on the limbers and waggons, in mountain and position batteries both gunners and drivers usually walk. Both horse and field batteries are recognized tactical units of an army, and are maintained in an efficient state in time of peace. Position batteries are organized generally in time of war, are possessed of the heaviest guns consistent with mobility, and are useful in certain special cases, such as the attack or defence of a fortified position, the bombardment of a town, &c. Mountain batteries consist usually of light guns mounted on the backs of mules, and are adapted solely for warfare in mountainous countries. See **ARTILLERY**. The term battery is also applied to the companies of dismounted artillerymen necessary to fight fortress and siege guns; to separate groups of guns in permanent works; and to the earthworks constructed for the protection of guns in siege operations.

**BATTERY**, as a law term, is the unlawful beating of another. See **ASSAULT**, vol. ii. p. 724.

**BATTEUX**, CHARLES, a French writer on philosophy and the principles of literature, was born near Vouziers in 1713, and died in 1780. In 1739 he came to Paris, and after having taught with success in the colleges of Lisieux and Navarre, was appointed to the chair of Greek and Roman philosophy in the College of France. In 1746 he published his treatise *Beaus Arts réduits à une même Principe*, in which he extended the Aristotelian definition of the art of poetry to art of all kinds. His *Cours de Belle-Lettres*, 5 vols., 1765, was afterwards included with some minor writings in the large treatise *Principes de la Littérature*, 1774. The rules for composition there laid down are, perhaps, too methodical and pedantic. His philosophical writings were *La Morale d'Épicure tirée de ses propres écrits*, 1758, and the *Histoire de Causes Premières*, 1769, a survey of the history of philosophy which is by no means devoid of merit. In consequence of the freedom with which he attacked in this work the abuse of authority in matters of philosophy, he was removed from his professorial chair. His last and most extensive work was a *Cours d'études à l'usage des élèves de l'école militaire*, 45 vols.

**BATTICALOA**, the chief town of a district in the Eastern Province of Ceylon, situated on an island in lat. 7° 44' N. and long. 81° 52' E. It is of importance for its haven and the adjacent salt lagoons. The inhabitants are principally natives; but there is a fort and an English settlement. Population of town, 3353, and of district, 93,220.

**BATTLE**, an engagement between two armies, as distinguished from the skirmishes, or minor actions, fought between their smaller sections. A battle is said to be general, where the whole or the greater part of each army is brought into action; and partial, where only brigades, divisions, or some corps d'armée out of several upon the ground, are engaged. However the numbers may vary, the great principles to be applied in delivering battle are at root in all ages the same. It is no doubt true that, in the circumstances under which battles are fought, there is nothing invariable; on the contrary, it is scarcely possible to suppose two cases alike in every particular, or even resembling each other in all their leading features. From the very nature of things, the minor data of the problem are variable; but the grand principles—those which depend on moral elements—continue immutably the same. On the other hand, the material elements which enter into the calculations of a general are constantly changing; and it is this circumstance which affords scope for the exercise of his genius, his sagacity, and his military science. But it would be manifestly absurd to maintain that, because the lesser conditions are so frequently altered, the great principles of the art are changed with them. The issue of battle is indeed always uncertain,—because the calculations of the general may be defective, his combinations unscientific, his foresight limited, or his temperament rash and impetuous; and because, even where none of these causes of failure exist, events which no human sagacity could have divined or provided against may occur to defeat the wisest plans. But all this implies that if every contingency could have been foreseen and properly met, the result would not have been doubtful, and that the grand chances are always on the side of him who, being provided with sufficient means for his end, forms his plan with the greatest sagacity, and executes it with corresponding vigour and ability. For, variable as the results of battles appear, decisive success has in all ages followed the combinations of great commanders; and victory in the long-run has seldom failed to pay homage to science. And this is because those principles which science has established as universally applicable depend on certain fixed laws in

human nature, which ages have not changed since history was first written. That undisciplined forces, for example, are easily shaken by panic arising out of any such sudden disaster as the fall of their general, was as true in the day when Ahab, for this reason, disguised himself at Ramoth-Gilead as it is now. That infantry, thoroughly broken up and exposed on open ground, may be taken or destroyed by a very inferior number of cavalry, was illustrated no less by Hannibal at Cannæ than by Murat's charge round the allied right at Dresden. The feeling that there was no safe retreat open in case of disaster was as fatal to the Persians at Marathon as to the French at Leipsic. The crushing effect of heavy columns pressing against a line (which, as only the outer part of the column can act, is purely moral) was quite as conspicuous in the victory of Epaminondas at Mantinea as when Napoleon cut his enemy's centre through at Ansterlitz. Above all, military history, from the earliest times, proves two facts of prime importance to commanders in every action: the one, that the best troops become unsteady when their flank is gained, just as a single man in a struggle desires to face fairly the adversary about to rush on him; the other, that a comparatively small body coming fresh into action with troops exhausted by the exertions and nervous tension of a battle, has an advantage over much larger numbers. And being thus fixed, these principles obviously yield certain general rules, to which every prudent commander of any age strives to conform. Circumstances may lead him to violate them, but the examples of Leipsic and Waterloo are there to prove that, even with the greatest of generals, the result may be ruinous. In the first case, the French were forced to fight with their backs to a river; in the second, by a combination they were not prepared for their flank was struck by the Prussians when they were fully engaged with Wellington in front; and total defeat ensued in both.

A battle is not only the most imposing, but also the most important event in war. It is the consummation to which all previous combinations necessarily tend; it is that grand act which may decide the fate of empires as well as armies. The highest and dearest interests of nations, nay, even of humanity itself, may be involved in its issue. It cannot, therefore, be uninteresting to look briefly at the theory of those received principles by the skilful application of which the fate of battles has in all ages been determined.

All the methods in which a battle can be fought may be reduced to three for abstract purposes, each governed by a distinct principle. The first, the purely defensive, consists in waiting for the enemy, in a position chosen for the purpose, the object being simply that of maintaining it successfully against him. Theorists almost universally condemn this, and that with good apparent reason; for there is something peculiarly trying to the moral endurance of even the best troops in feeling that they are pinned to one spot to await the assaults of the enemy without any prospect of retaliation. But the rule is not without exceptions, as is plainly proved by comparing the two great examples of purely defensive actions fought during the campaigns of 1862-63 in America,—Fredericksburg and Gettysburg. The defender in each case was perfectly successful, beating off his assailant with tremendous loss; but the results were very opposite. Lee's victory at Fredericksburg stopped, indeed, the advance upon Richmond for the time, but did not seriously affect the course of the war. Meade, on the other hand, by beating the Confederates off at Gettysburg, completely turned the tide of the campaign, and compelled Lee to abandon all idea of invading the North and commence a difficult retreat to Virginia; while thenceforth Washington was saved from all danger of being separated from the states that supported the union. This was because the position maintained at Fredericksburg

was no more than one point on a single line of advance direct upon Richmond, whereas that of Gettysburg was so completely the key to the whole of the campaign of Maryland, that, whilst it was held by Meade, it was impossible for Lee to advance beyond it or any part of the north-eastern states. The failure to carry it therefore paralyzed the whole scheme of the Confederates for transferring the burden of the struggle to hostile soil. And from a comparison of the varying consequences of these actions, so similar in their course, it will be seen that the defensive battle is justified only when the position to be maintained is one of vital consequence for the enemy to seize in order to carry on further operations with success. Lee has been fairly condemned by even friendly critics for not turning his defensive attitude at Fredericksburg into an offensive on the repulse of the enemy's attack. No one blames Meade for the like conduct at Gettysburg, because his holding his ground fully accomplished all that it was necessary for him to do. But such an instance as this last, it should be added, can but rarely occur.

The second system is the entirely-offensive,—in plain words, the attacking the enemy wherever found, with all force available. As it carries with it the moral power which in all ages is found to accompany, until some decided check occur, bodies of disciplined men moving freely forward to the assault, and as it gives the leader the power of choosing the weaker points of his adversary's line on which to concentrate his blows, so it has ever been the favourite with bold and skilful generals leading good troops. Frederick and Napoleon alike preferred it, and won some of their chiefest victories by using it freely. Wellington employed it with marked success in the latest phases of the Peninsular War in 1813-14. Grant adopted it avowedly in his great struggle with Lee in Virginia in 1864. And the Prussians fought on this principle throughout the two great wars of 1866 and 1870-71. History, however, shows that it is only fully justified when the attacking general has a force decidedly superior either in numbers or in moral power; or when, as in the famous case of Frederick at Leuthon, he possesses such extraordinary skill in manœuvring as to give him all the advantages of long odds, although engaged against superior numbers. It has the serious defect that if the defence prove more successful than was expected, the assailant may have to bring up successively and exhaust all his forces, and thus leave himself without any reserve to meet a sudden onset from the opposite side. In such case defeat probably entails the complete wreck of the hitherto offensive army, and with it possibly the loss of the campaign.

It is for this reason that prudent commanders are wont, where the choice lies with them, to select the third mode, the defensive-offensive, or a combination of the two preceding. This consists in taking up a position with the design of awaiting the adversary's attack on it, but also of watching the opportunity afforded by the exhaustion of his army in its assaults, or by his extending it too widely in choosing the best points from which to make them, in order to pass suddenly to the offensive. Wellington is justly famous for the success with which he employed this form of action. But it is one of the highest tests of generalship to know exactly when most fitly to use either. And as Napoleon won three at least of his most striking victories,—Marengo, Ansterlitz, and Dresden,—by passing at the right moment suddenly from an apparently passive attitude of defence to a vigorous offensive, so Wellington, after all the world had come to regard him as great only on the defensive, used the strictly offensive form, with the like success at Vitoria, Orthez, and Toulouse, the last of these three actions being one of such apparent temerity as can hardly be paralleled in modern history, and yet perfectly



justified by his instinctive knowledge of the demoralized state of the enemy whose position he undertook to force. Marlborough, who as a fighter of great battles has never been surpassed, and who, like Wellington, led a mixed army of English and allies, appears to have always had a decided preference for the offensive;—so little does nationality supply any just rule for selecting either. Marlborough's choice, in all probability, was adopted from the comparatively passive attitude of his various adversaries at Blenheim, Ramillies, and Malplaquet, which tempted a bold offensive on his part. Lee, though certainly addicted to the strictly defensive, which was suited to his inferiority of numbers and to the strong nature of the ground he usually occupied, had the true instinct (as was especially shown in his great victory at Chancellorsville) of seizing any special opportunity offered by the carelessness of an adversary who brought against him apparently overwhelming forces. And in the late war, although the German generals elsewhere continually took that bold offensive which was justified at first by superior numbers, and later by the increasingly high spirits of their troops, yet in the most important and bloodiest action of the whole, Mars-la-Tour, they were content, after it had been well begun by their own attack, to pass to the completely defensive,—it being evident that by merely maintaining the position they had taken up across the French line of retreat from Metz, all the immediate advantage possible from victory would be won.

On the whole, therefore, it may be affirmed that no theory is sound which prescribes or forbids the use of any of the three methods, or lays down strict rules for the application of any of them. Defence is, however, the natural attitude of the weaker party, as Clausewitz, the greatest of all theoretical writers on war, has carefully pointed out. Under what conditions it is to be accepted, or how long adhered to when once assumed, are problems which it requires true genius to grapple with successfully; for they can only be solved rightly according to the circumstances of the hour, perhaps of the moment. To see a crucial instance illustrated by a failure, we may look at Gravelotta. There Bazaine was forced by the case to fight on the defensive. An opportunity occurred in the day, on the decided repulse of the German right-wing under Steinmetz, of striking such a counterblow as, from Napoleon's hand, would probably have forced a victory over even the great odds possessed by the German commander. But Bazaine had no spark of the instinctive genius needed. He lost the opportunity, and with it the battle,—the loss entailing the last hope of rescuing his host from the dangerous and indeed ignominious position in which previous errors of judgment had placed it.

In conclusion, in order to demonstrate the undying truth of the main principle of battle, which is that, the general conditions being equal, the moral advantage is invariably at the outset with the offensive rather than the defensive,—with the army that feels itself moving forward rather than that which stands still,—it is well to refer to the recent discussion on the effect of breech-loading arms. It was almost universally assumed by theorists, especially by those of Prussia herself, when she first put the needle-gun into her soldiers' hands, that the power of the new weapon would be most perceptible in defence, for which its more rapid fire seemed so specially adapted. The Prussian instructions, drawn up before 1866, avowedly followed this view. Those who compiled them overlooked the fact that the moral power of the weapon would of itself tend to carry those who bore it forward, and add an additional advantage to those the assailant had before in his greater show of vigour and activity, and his power of searching out the weaker parts of his enemy's position and throwing his troops in force upon them. History has reversed the Prussian theory, and proved afresh how powerful for victory

is the moral element in the soldiers' character. For, out of the opening events of 1866, and the vast encouragement the Prussians experienced in their first collisions with Benedek's army, has been evolved the most audacious and aggressive series of actions any nation ever fought. Certain Prussian writers have since the war of 1870-71 gone almost to the opposite extreme, and claimed absolute superiority for the offensive under all circumstances, forgetting that, against a stronger army, or even one perfectly equal in all other respects and well posted, it must inevitably be as dangerous as it proved when confidently tried by Napoleon's marshals against British troops under Wellington.

The various so-called "orders of battle" of which theoretical writers treat, believing that they see a close similarity in the dispositions of well-led armies from the days of the Grecians down to our own, are, so far as such similarity really exists, founded entirely on one or other of the moral elements already mentioned, above all, on the desire to gain the enemy's flank. The late General Winfield Scott, one of the few commanders who could boast that he had more than once seen the back of English infantry in fair fight, declared that this desire is so instinctive that it is impossible to array two bodies of disciplined troops against each other without one at least soon striving for this advantage. But so far as this and other like universal principles are applied to the actual drawing up of an army at any period in a special order of battle, the arrangements must in practice vary with the arms and discipline. This subject, in fact, forms part of that special art which treats of the handling of troops in the presence of the enemy, and falls under the head of "tactics," for which see the article WAR. The mechanism of battles must vary continually; the great leading principles we have spoken of cannot change.

See Jomini, *Traité des Grandes Opérations Militaires*; The Archduke Charles's *Strategy* (2d and 3d vols.); Rogiat, *Considérations de l'Art de la Guerre*; Clausewitz's work *On War*; Boguslawski's *Tactical Deductions from the War of 1870-71*; Soherl's *Studien*, "Die Schlacht;" above all, Napoleon's criticisms on other generals in his *Memoirs*. (G. C. C.)

**BATTLE**, a market-town in the county of Sussex, on the South-Eastern Railway, 56 miles from London. It is situated in a valley, and consists of one street. Its name is derived from the conflict in 1066, which insured to William the Norman the crown of England. The abbey founded by him forms a most magnificent pile of ruins, and the ancient gatehouse is still in good preservation. The place is now celebrated for its gunpowder manufactories. Population of the parish in 1871, 3496.

**BATTUS**, the founder of the Greek colony of Cyrene in Libya, whither he had been directed by the oracle at Delphi (about 650 B.C.). The Greeks who accompanied him were, like himself, natives of Thera (Santorin), and partly descended from the race of the Minya. The origin of the colony as told in Thera (*Herodotus*, iv. 150) was as follows:—

Grius, king of that island, had gone attended by Battus and others to consult the oracle at Delphi, and was told by it to "found a city in Libya." They knew not where Libya was, and could take no action. Seven years after there fell a drought on Thera, and the oracle, being again questioned, repeated the command to found a town in Libya. Messengers were now sent to Crete to see if any one there knew where this district was. They met a fisherman, Corobius, who said that he had once been driven to Platea, an island of Libya, whither he agreed to conduct them. To make sure, they went with him; and having landed on Platea, they again, leaving Corobius there with provisions for some months, returned to Thera to collect colonists, of whom as many as two 50 oared galleys could convey set out with Battus as their leader. In Cyrene itself, however, a different story of the origin of the colony was told. Etearchus, it was said, king of Axus in Crete, having married a second wife, who persuaded him to get rid of Phronime, the daughter of his first wife, agreed with a merchant from Thera that he should take her in his ship and let her down into the sea. The merchant, true to the letter of his bargain, let her down, but with a rope about her by which he drew her up again, and took her to Thera, where she married

Polymnestus, a descendant of the Minya, and bore him a son, who, because of his stuttering, was called Battus. On growing to manhood, Battus inquired at the oracle of Delphi about his voice, and when told to "found a town in Libya," was unable to understand the response. Afterwards, owing to misfortunes, the Tharmans sent to Delphi for advice, and were again ordered to send a colony to Cyrene, under Battus, which they now did, landing first in Platea, and afterwards removing to Cyrene itself.

Herodotus (iv. 155) thinks that the name of Battus, being the word for "king" in Libya, had been applied to the leader of the colony after his arrival there, and that it had no reference to his stuttering. Battus having ruled forty years (about 630-590 a.c.) was succeeded by his son Arceilaus, who, after a reign of sixteen years, of which nothing is known, was followed by Battus II. Of this dynasty, known as the *Battidae*, the names were alternately Battus and Arceilaus, there being, as the oracle predicted, probably after the fact, four of each. Under Battus II., surnamed the Prosperous, the population of Cyrene was increased by a large number of colonists from all parts of Greece invited by a promise of land. To find land for all it was necessary to dispossess many of the native Libyans, who therefore sought and obtained the aid of an Egyptian army, which, however was completely defeated. Amasis, the next king of Egypt, proved friendly to Cyrene. The reign of Arceilaus II. (about 554-544 a.c.) is known only for the disastrous battle with the Libyans, who had been stirred to revolt by his brothers, in which he lost 7000 hoplites. He himself soon after fell ill, and was strangled by his brother Learchus. The disgrace of the ruling family being increased by the fact that the next heir, Battus III., was lame, the oracle at Delphi was consulted, and advised that affairs should be placed in the hands of Demonax of Mantinea, who distributed the people into three tribes, and arranged a form of self-government for them. Battus, retaining the royal lands and sacred offices of a king, acquiesced. Not so his wife Pheretime and son Arceilaus, who bestirred themselves,—the former in Cyprus, the latter in Samos,—to raise forces to recover the sovereignty, and ultimately succeeded; but in his success Arceilaus III. forgot the commands of the oracle (*Herod.*, iv. 163), and, among other cruelties to the vanquished, burned alive a number of them who had escaped to a tower. To avoid the consequences he retired to the town of Barca, but was there slain in the market-place by some fugitives from Cyrene. His mother, Pheretime, who had been regent in his absence, now obtained from Aryandes, the Persian satrap of Egypt, an army to take vengeance on the people of Barca. After a fruitless siege of nine months (*Herod.*, iv. 200) a treaty of peace was solemnly sworn to by the Persian general, and was instantly broken in spirit, though not in letter, when the gates of Barca were thrown open. Pheretime, ruthless in her cruelties towards those who had been connected with her son's murder, herself died soon after, a wretched death, in Egypt. Of Battus IV. nothing is known. Arceilaus IV., with whom the dynasty ended (about 460-445 a.c.), obtained twice the victory in the chariot race at the Pythian games, and for this was celebrated by Pindar in two odes (*Pyth.*, iv. and v.).

BATU, a thickly-wooded island lying off the north-western coast of Sumatra, 40 miles in length by 10 in average breadth, almost immediately under the equinoctial line. Cocoa-nuts, oil, and trepang are exported. It is the seat of an active volcano. The inhabitants are a colony from the island of Nias.

BATUM, a seaport town of Asiatic Turkey, in the pasha'ic of Trebizond, and 110 miles N.E. of the city of that name. It is situated on the Black Sea, not far from the mouth of the Chorak, and the harbour is the safest and most important on the eastern coast. There is deep water close to the shore, and protection is afforded by the high

overhanging cliffs of a spur of the Gourial Mountains. The situation of the town is marshy and unhealthy; and the place itself is "filthy in the extreme." It is now the seat of a *mutessary*, or deputy-governor; and the Turkish authorities are fortifying it with several strong batteries. A dilapidated *ronak*, or governor's house, two mosques, and a Greek church are almost the only buildings that relieve the meanness of the squalid-looking huts; but the natural and political position of the place render it of commercial and military importance. There is a custom-house, a Russian consulate, and a steamer agency; and the Russian steamers regularly use the harbour as a port of transhipment, their own harbour at Poti being insecure. A considerable contraband trade is carried on across the frontiers, as well as a moderate amount of regular exportation by sea. The population does not exceed 2000.

BAUDELAIRE, CHARLES, who would have been pleased to be considered as a master in the French Satanic school of poetry, was born at Paris in April 1821. He was the son of a man of some distinction, who had been the friend of Condorcet and of Cabanis. The poet's life contained no episode more important than a voyage to the East Indies, where he resided for some time, and whence he brought perhaps the Oriental languor and the curious delight in perfumes which make themselves felt in many of his verses. Baudelaire returned to Paris while still a very young man, and sought the literary, or at least what is called the Bohemian society of the capital. He admired M. Théophile Gautier, as M. Gautier had admired Victor Hugo, and his poems are all conceived in the school of Romanticism. Romanticism, or, to define it rather widely, the school of revolt against French academic taste, the search for remote experiences, the artistic reproduction of the excesses and vagaries of passion, found in Baudelaire its most reckless disciple. Some portions of his verses, *Les Fleurs du Mal*, appeared originally in the *Revue des Deux Mondes*, and when they were published in a volume, had the misfortune to attract the notice of the police. When so many low unwholesome works were published without scandal, it was an effort to attract notice to the verses of Baudelaire. The chief notes of his poetry are a perverse delight in loathsome subjects, a curious reaction towards Christianity and repentance, a pleasure in the last refinements of art, above all an unsleeping self-consciousness and affectation. Less unpleasant than his *Fleurs du Mal*, are his exquisite and gem-like *Petits Poèmes en Prose*, and his volumes of subtle and ingenious criticism. Baudelaire died in 1867 at the age of forty-six, after a long illness. He will possibly be best remembered for his translation of the works of Edgar Allen Poe, one of the most accurate and brilliant translations in literature. The impression left on the reader by Baudelaire's life and industry is rather a painful one. It is difficult to be blind to the fact that he lived for notoriety, and that he preferred to gain notoriety by a distinguished activity in the least wholesome fields of letters. His poems represent the high-water mark of the tide of Romanticism; and it may be hoped that the taste for lepers and corpses in poetry will now gradually decline. The best edition of his works, prose and verse, is that published by Michel Levy, Paris. Some of his suppressed poems were printed in Brussels, under the title *Les Épaves*.

BAUHIN, GASPARD, the son of an eminent French physician, who had to leave his native country on becoming a convert to Protestantism, was born at Basel in 1560. Early devoting himself to medicine, he pursued his studies at Padua, Montpellier, and some of the celebrated schools in Germany. In his journeys through various parts of Europe he collected a number of plants which had escaped his elder brother's notice. Returning to Basel in 1580, he was admitted to the degree of doctor, and gave private lectures

in botany and anatomy. In 1582 he was appointed to the Greek professorship in that university, and in 1588 to the chair of anatomy and botany. He was afterwards made city physician, professor of the practice of medicine, rector of the university, and dean of his faculty. He published several works relative to botany, of which the most valuable is his *Pincas Theatri Botanici, seu Index in Theophrasti, Dioscoridis, Plinii, et botanicorum qui a seculo scripserunt opera*, 4to. The confusion that began to rise at this time from botanical writers describing the same plant under different names rendered such a task highly necessary; and though there are many defects in the execution, the *Pincas* of Bauhin is still a useful key to all the writers before his time. Another great work which he planned was a *Theatrum Botanicum*, meant to be comprised in twelve parts folio, of which he finished three; only one however was published. He also gave a very copious catalogue of the plants growing in the environs of Basel, and edited the works of Matthioli with considerable additions. He likewise wrote on anatomy; his principal work on this subject is *Theatrum Anatomicum in finitiss locis auctum*, 4to, Frankfurt, 1621, which is a kind of *pincas* of anatomical facts and opinions. He died in 1624.

BAUHIN, JEAN, brother of the above, was born at Basel in 1541. He studied at Tübingen under the celebrated botanist Fuchs, and afterwards travelled with Conrad Gesner, and collected plants in the Alps, in France, and in Italy. He first practised medicine at Basel, where he was elected professor of rhetoric in 1566. He then resided for some time at Yverdon, and in 1570 was invited to be physician to the duke of Würtemberg at Montbéliard,—a situation in which he spent the remainder of his life. He devoted his time chiefly to botany, on which he bestowed great labour. He likewise prosecuted other branches of natural history, and published an account of *Medicinal Waters throughout Europe*. His great work on plants was not completed at his death, which happened in 1613. A society at Yverdon published in 1619 the "*Prodromus*;" but it was not till 1650 and 1651 that the work itself appeared, in three vols. folio, entitled *Historia Plantarum nova et absolutissima, cum auctorum consensu et dissentiu circa ea*. It was long considered a standard work, and, with all its defects, it entitles its author to a high place among the founders of botanical science.

BAUMÉ, ANTOINE, a French chemist, distinguished for his success in the practical application of the science, was born at Senlis in 1728. He was the son of an innkeeper, and had to contend with the disadvantages of a defective education, in spite of which he prosecuted his scientific researches with great success. He was apprenticed to the celebrated chemist Geoffroy, and in 1752 was admitted a member of the college of pharmacy; soon after he was appointed professor of chemistry at that establishment. He carried on a commercial establishment in Paris for the preparation, on an extensive scale, of drugs for medicine and the arts, such as the acetate of lead, the muriate of tin, mercurial salts, and antimonial preparations. At the same time he published a number of papers on chemical science, and on arts and manufactures. He established the first manufactory of sal-ammoniac in France, a substance which before that time had been obtained from Egypt. He was the first also who devised and set on foot a process for bleaching raw silk. Having acquired a competency by the success of these different undertakings, he retired from trade, and devoted his time to the application of chemistry to the arts. He improved the process for dyeing scarlet at the manufactory of the Gobelins, and announced a cheap process for purifying salpêtre. By the Revolution he lost his fortune, but this calamity, instead of disheartening him, stimulated him to resume his trade. He was chosen a

correspondent of the Institute in 1796, and died in 1804, at the age of seventy-six. Many of his papers are published in the *Memoirs of the Academy of Sciences*. Of his separate publications, the following may be mentioned here: *Dissertation sur l'Ether*, in 12mo; *Plan d'un Cours de Chimie Expérimentale*, 1787, in 12mo; *Opuscules de Chimie*, 1798, in 8vo; *Éléments de Pharmacie Théorique et Pratique*, 2 vols. 8vo; *Chimie Expérimentale et Raisonnée*, 3 vols. 8vo, 1773.

BAUMGARTEN, ALEXANDER GOTTLIEB, a German philosopher, born at Berlin in 1714. He studied at Halle, and afterwards became professor of philosophy at Frankfurt on the Oder, in which city he died in the year 1762. He was a disciple of Leibnitz and Wolff, and was particularly distinguished for his æsthetical speculations, having been the first to develop and establish the *Theory of the Beautiful* as an independent science. Baumgarten, of course, is not to be looked upon as the founder of æsthetics, but he did good service in severing it from the other philosophic disciplines, and in marking out a definite object for its researches. The very name (*Æsthetics*) which Baumgarten was the first to use for the science of the Beautiful, though now very generally adopted for the sake of convenience, indicates the imperfect and partial nature of his analysis, pointing as it does to an element so variable as *feeling or sensation* as the ultimate ground of judgment in questions pertaining to beauty. The principal works of Baumgarten are the following: *Disputationes de nouis ad poema pertinentibus*; *Æsthetics*; *Metaphysica*; *Ethica philosophica*; *Initia philosophica practica prima*. For an account of his speculations on the theory of the Beautiful see *ÆSTHETICS*, vol. i. p. 217.

BAUMGARTEN-CRUSIUS, LUDWIG FRIEDRICH OTTO, a distinguished German theologian, was born in July 1788 at Merseburg. In 1805 he entered the university of Leipsic, and studied theology and philosophy. In 1812 he was appointed extraordinary professor of theology at Jena, where he remained to the end of his life, rising gradually to the head of the theological faculty. In the midst of his labours as professor and author, he was struck down by apoplexy, and died on the 31st May 1843. Baumgarten-Crusius lectured on almost all the theological disciplines, with the exception of church history; but his great strength lay in the treatment of the history of dogma. His comprehensive knowledge, accurate scholarship, and wide sympathies gave peculiar value to his lectures and treatises on the development of church doctrine. His published works were very numerous, the most important being—*Lehrbuch der Christlichen Sittenlehre*, 1826; *Grundzüge der biblischen Theologie*, 1828; *Lehrbuch der Dogmengeschichte*, 1832; *Compendium der Dogmengeschichte*, 1840. The last, perhaps his best work, was left unfinished, but was completed in 1846 by Hase from the author's notes. Commentaries on several of the books of the New Testament, gathered from his papers, were also published after his death.

BAUR, FERDINAND CHRISTIAN, the distinguished leader of the Modern Tübingen School of Theology, was born in the neighbourhood of Cannstadt on the 21st June 1792. The son of a Würtemberg pastor he entered, at the age of thirteen, the well-known seminary at Blaubeuren, to which his father had some years before been transferred as deacon. Thence he passed, in the year 1809, to the university at Tübingen. Solid and somewhat reserved in character, he was indefatigable in his studies, but did not come prominently to the front till near the close of his academic career. His intellectual development proceeded slowly from step to step. For a time he was attracted and considerably influenced by the study of Bengel, the great head of the preceding orthodox school, which had given

Tübingen its reputation in the 18th century. Both Bengel himself in his noble personality, and the historical character of his critical labours on the New Testament, remarkable for their time, had a charm for the youthful student of the 19th century. With historical interest Baur combined a special interest in the philosophy of religion, but as yet without betraying any opposition to the supernatural standpoint of the older theology. His earliest literary production—a review of Kaiser's Biblical Theology (Bengel's *Archiv für Theologie*, ii. 656) in 1817—shows nothing of this opposition. It required a change of circumstance, as well as a new impulse of intellectual excitement, to direct his thoughts into the bolder current, in which they were destined to run, and in their course so largely to affect the stream of contemporary thought.

In 1817 he was called as professor to Blaubeuren, which he had left as a pupil eight years before. It was his business here to direct the historical and philosophical studies of the youth, and his keen and comprehensive genius soon found a congenial subject of investigation in the relations of Christianity to preceding modes of thought. The result of his investigations appeared in his *Symbolik und Mythologie*, in 1824: This was his first elaborate work, the precursor of all his special studies in religious history and the development of religious thought. Animated by a thorough and enlightened spirit of learning, and valuable as a contribution to the knowledge of classical antiquity, it was yet dominated by a theological interest, and showed how truly this was the prevailing bias of the author's mind. It showed, moreover, how from this early period he combined, in almost equal force, the three great elements of culture—philological, philosophical, and theological—which his later works discovered in such maturity.

This publication drew attention to Baur's marked abilities, and, on a vacancy occurring in the theological faculty at Tübingen, he was promoted after some hesitation to the chair of historical theology in that famous university, destined from his labours to acquire a yet more notable reputation. This took place in 1826; and for thirty-four years Baur's life was passed at Tübingen in an unceasing round of academic work,—while his name continued to gather from his successive writings an increasing lustre and influence. All accounts agree in testifying to his marvellous industry and unceasing toil of research, his conscientiousness and self-sacrifice as a teacher, and the unobtrusive enthusiasm and dignity with which he discharged all the duties entrusted to him, not only as a professor, but as for some time the head of the *Stift*, or college of residences for the Protestant divinity students. His theological opinions, trenchant and alarming as they must have sometimes appeared, never made any separation betwixt him and his colleagues in the theological faculty. All acknowledged his power and earnestness; and the multitudes who thronged his lecture rooms carried the impulses of his thought throughout Germany and Switzerland. His manner was somewhat reserved and silent; all his enthusiasm was put into his work, and was felt more as an underglow animating his lectures and writings than as a demonstrative power creating a temporary noise. He lived for theological science: nothing else seems to have occupied him or drawn him aside. When we add to this the fact that any faith in supernatural religion, with which he began his labours as a professor, ere long disappeared, and that the great aim of all his studies and researches was to find the natural factors or principles out of which Christianity arose in the world, there is presented to us a strange picture of theological enthusiasm. It may seem an inconsistent and unhappy picture. Yet there is something heroic if also pathetic in such intense application

to the study of Christian phenomena, and such thorough and earnest aims to reach the truth regarding them, without the faith which witnesses to the reality of a personal divine life, behind the phenomena and revealed in them.

Baur at first, like almost all his contemporaries, owned the influence of Schleiermacher. The *Glaubenslehre* of the latter, which appeared in 1821, is said to have affected him deeply, and moulded his thought for some time. But there was too little affinity betwixt the men,—the one mystic and spiritual, the other intellectual and objective,—to permit this influence to be permanent. From Schleiermacher Baur passed to Hegel, whose commanding genius laid its spell upon him as upon others. The Hegelian philosophy became the permanent and pervasive element of his intellectual life. Its great doctrine of opposites, or of extremes finally terminating in a conciliation, is found more or less to underlie all his thought, and to furnish the key to his most daring speculations on the origin and growth of Christianity.

It was not, however, till nearly ten years after his settlement at Tübingen that his theological views underwent a decided change, and that the special tendency known as that of the Modern Tübingen School was fully developed. The earlier period of Baur's academic life was not unfruitful, but did not mark him off in any striking manner. Even his treatise on the *Christ-party in the Corinthian Church and the Antagonism betwixt the Pauline and Petrine Christianity*, which appeared in 1831, and which may be said to contain the germs of his future system, was published peaceably (in the *Tübingen Zeitschrift*) along with the effusions of Slendel, one of his co-professors most devoted to supernaturalism. His answer to Möhler's famous *Symbolik* (1833) attracted a widespread reputation, and fixed attention upon him as one of the ablest defenders of German Protestantism. Masterly and ingenious as Möhler's book was, it was felt that Baur had not only fairly met but overthrown its chief position. But with all his reputation as a powerful writer and controversialist, he had hardly as yet made his mark as a new thinker.

The second and distinctive period of his intellectual development is dated from the year 1835, when Strauss's *Leben Jesu* appeared, and spread commotion in the theological mind of Germany. In the same year Baur published his great work on Gnosticism, in which he had obviously quite passed beyond the influence of Schleiermacher. A brief work on the *So-called Pastoral Epistles* in the same year showed him at work in an independent critical direction, and ready to take a new start in theological inquiry. This start, or at least the lengths to which it carried him, have been by many attributed to the effect of Strauss's work. But he has himself plainly denied this, and claimed an independent origin for his own speculations. "I had begun," he says (*Kirchengeschichte des 19 Jahrhunderts*, 396), "my critical inquiries long before Strauss, and set out from an entirely different point of view. My study of the two epistles to the Corinthians led me first to seize clearly the relation of the apostle Paul to the other apostles. I was convinced that in the letters of the apostle themselves there was enough from which to infer that this relation was something very different from that usually supposed,—that, in short, instead of being a relation of harmony it was one of sharp opposition, so much so that on the part of the Jewish Christians the authority of the apostle was held everywhere in dispute. A closer investigation of the Pseudo-Clementine homilies, to whose significance in reference to the earliest period of Christian history Neander first drew attention, led me to a clearer understanding of this opposition; and it always became more evident to me that the contrast of the two parties in the Apostolic and sub-Apostolic age must be traced

not merely in the formation of the Petrine tradition but as having exercised an important influence upon the composition of the Acts of the Apostles."

This supposed conflict betwixt Petrinism and Paulinism, or, in other words, betwixt Jewish and Gentile Christianity, lies at the foundation of all Baur's critical labours. His speciality as a New Testament scholar and critic was the firmness with which he laid hold of what he believed to be the only genuine foundation of historical Christianity in St Paul, and his four great epistles to the Corinthians, to the Galatians, and to the Romans. These epistles were to him alone unchallengeable as the authentic writings of the great apostle of the Gentiles, and the antagonism of which he made so much appeared to him everywhere to pervade them. The epistles to the Ephesians, to the Colossians, and to the Philippians, and the short letter to Philemon, were at the best doubtfully genuine. They seemed to him to bear traces of a later Gnosticism in many of their expressions, while he altogether rejected the apostolical character of the Pastoral Epistles. These letters, as well as the Acts of the Apostles, were to him writings not of the 1st but of the 2d century, proceeding not from the Pauline School, but from the Catholic and Conciliatory School, which towards the middle and end of the 2d century sought to adjust and harmonize the earlier conflicting elements of Petrinism and Paulinism. This impress of conciliation and compromise appeared to him to be specially stamped upon the Acts of the Apostles, and to be the true explanation of the relations there depicted betwixt St Peter and St Paul.

Such were the views advocated by Baur in a succession of writings on the Pastoral Epistles (1835) and the Epistle to the Romans (1836); but especially in his great work on the Apostle Paul (1845), which may be said to sum up the result of his critical labours on the Pauline writings.

Then in a further series of critical investigations he turned his attention to the Gospels. He dealt with them as a whole, "their relation to one another, their origin, and character," in a treatise which appeared in 1847, and in 1851 he devoted a special volume to the gospel of St Mark. The result of his investigations in this direction was to satisfy him that all the Gospels owe their origin more or less to the same tendencies or traces of party design, which he everywhere discovers in the first Christian age. Our present Gospels are not, in his view, the most ancient documents of the kind possessed by the church. Before them there was a primary cycle of evangelical tradition, known by various names—as the gospel of the Hebrews, of St Peter, of the Ebionites, of the Egyptians, &c. In the existing canon the Gospel of St Matthew resembles those earlier narratives most closely. It reproduces most completely the character of the primitive Jewish Christianity, yet not without important later modifications. The Gospel of St Luke is, of course, of Pauline origin, yet also retouched with a view to the conciliatory tendencies of the Church of the 2d century and the influence of the Petrine tradition. That of St Mark is of later date than either, and bears the most evident traces of adaptation. Of all the gospels it is the most suspected by the Tübingen School. The Fourth Gospel, on the other hand, is a definite work, but of the 2d, not of the 1st century. An examination of its contents, its mode of composition, and its general plan clearly reveals its dogmatic and idealistic character. The historical data are merely a background to the speculative ideas which it unfolds. The prologue by itself is sufficient proof of its logical method and purpose, while the contrasts which everywhere pervade it betwixt light and darkness, life and death, the Spirit and the flesh, Christ and the children of the devil, and the dramatic force and propriety with which these contrasts are handled throughout, point to

the same conclusion. Further, the differences betwixt the Apocalypse and the Fourth Gospel are held to show conclusively that they could not have proceeded from the same author.

In addition to these critical labours Baur distinguished himself by a series of elaborate historical monographs on special doctrines of Christianity, for example his *History of the Doctrine of the Atonement* in 1838, and his *History of the Doctrine of the Trinity and Incarnation*, in 3 volumes, in 1841-3. His unceasing activity further produced a *Handbook of the History of Dogma* in 1847, an interesting tract on the *Chief Epochs of Ecclesiastical History* (1852), an admirable digest of his general views on the origin and growth of the early church under the title of *The Christian Church of the First Three Centuries* (1853). A further volume of general Church History from the 4th to the 6th century, appeared from his pen just before his death (1859), and subsequently three volumes containing the History of the Church of the Middle Ages (1861), the History of the Church of more recent times (1863), and the Christian History of the 19th century (1863). Finally, in 1865, appeared *Lectures on the History of Christian Dogma*.

His death took place on the 2d December 1860. He lies buried in the cemetery at Tübingen, not far from the poet Uhland, with the simple inscription on his tomb, "F. C. Baur, Theolog."

Such an amount and variety of authorship sufficiently show Baur's indefatigable industry and enthusiasm as a theologian; and when it is remembered that all his works are of a strictly scientific character indicating everywhere original research, and a penetrating and systematic intelligence which never slumbers, however it may be mistaken, it is evident that there are few names in the recent history of theology that claim more significance than that of Ferdinand Christian Baur. Of the value of his labours and the extent to which his theological views may be said to have verified themselves in the modern mind which has continued profoundly agitated by the problems which he started, this is not the place to speak. It need only be said that, while many of his opinions are strongly contested, and some of the most enlightened recent investigations prove that he has greatly exaggerated the antagonisms of the early church, and post-dated most of the writings of the New Testament, it is at the same time admitted by all advanced scholars that he has, even, in his exaggerations, contributed to a clearer view of the great principles at work in the 1st and 2d centuries and the lines of spiritual movement along which the Christian church moved to its historical formation and development. No student since Baur can fail to recognize the distinctive influences of Jewish and Gentile Christianity, and the extent to which this distinction, and in some cases antagonism, are impressed upon the New Testament writings. To him also and his school must be attributed the modern idea that the surest historical foot-hold of Christianity is in the four great Pauline epistles. These, more than any other New Testament writings, lie in the clear dawn of the sun-rise which enlightened the world. The Gospels remain, not indeed in a mist of unauthentic story, but in comparative shadow. They come only gradually into the light after a long dim undergrowth in the rich soil of Primitive Christianity. There is much to be said against Baur's views of their later origin in the 2d century. The more this century is studied the less does it seem capable of originating such marvellously fresh products of spiritual intelligence. But it is not the less certain that the Synoptic Gospels took their present form only by degrees, and that while they have their root in the Apostolic Age and the Apostolic mind, they are also fashioned by later influences, and adapted to special wants in the Early

Church. They are the deposits, in short, of Christian tradition, handed down first of all, and probably for a considerable period, in an oral form, before being committed to writing in such a form as we now have them. This, which is now an accepted conclusion with every historical school of theologians in England no less than in Germany, conservative no less than radical, is largely the result of the Tübingen investigations. It may have been understood before, but its historical significance was not appreciated. In short, if we distinguish Baur's method from his special opinions it is hardly possible to overrate his influence as a theologian. His professed method was to seek for the solution of great spiritual as of great intellectual phenomena in a closer and more minute study of all the documents and data purporting to record or explain these phenomena, and to run out such lines of fact as he found to their true consequences. His great genius and learning enabled him to read the meaning of certain features of Primitive Christianity hitherto imperfectly discerned, and to point future inquirers along the true road of discovery. Unhappily, his own opinions were influenced not merely by his study of facts, but by a great speculative system which dominated his intelligence, and prevented him from seeing what still seems to most minds not less informed than his own the only credible explanation of the vast spiritual movement whose forces and developments occupied his lifelong study.

(J. T.)  
**BAUTAIN, LOUIS EUGÈNE MARIE**, a French philosopher and theologian, was born at Paris in February 1796, and died in October 1867. At the Ecole Normale he came under the influence of Cousin, whose views on most philosophic points he at first accepted. In 1816 he adopted the profession of higher teaching, and was soon after called to the chair of philosophy in the University of Strasbourg. He continued in this position for many years, delivering a parallel course of lectures as professor of the literary faculty in the same city. The strong reaction against merely speculative philosophy, which carried away such men as De Maistre and De Lamennais, was not without influence on Bautain. In 1828 he took orders, and resigned his chair at the university. For several years he remained at Strasbourg, lecturing at the Faculty and at the College of Julliy; but in 1849 he set out for Paris as vicar of the diocese. At Paris he obtained considerable reputation as an orator, and in 1853 was made professor of moral theology at the theological faculty. This post he held till his death. Bautain is rather a scholastic than a modern philosopher. His view of the relation between reason and faith is essentially the same as that of Anselm and his great successors. Revelation is supposed to give materials which could not otherwise have been attained by the human mind, and philosophy supplies the scientific exposition or evolution of these facts. Theology and philosophy thus form one com-

prehensive science: yet the system is far removed from Rationalism. Bautain in fact, like Pascal, Newman, and others, depreciates reason in order to exalt faith. He points out, following chiefly the Kantian criticism, that reason is limited in application, and can never yield knowledge of things as they are in themselves. But in addition to reason, we have, according to him, another faculty which may be called Intelligence, and through which we are put in connection with the world of spiritual and invisible truth. This intelligence does not of itself yield a body of truth; it merely contains the germs of the highest ideas, and these seeds are made productive by being brought into contact with revealed facts. This fundamental conception Bautain works out in detail in the departments of psychology and morals. His works, to which we can only refer, are well deserving of attention. The most important of them are—*Philosophie du Christianisme*, 1833; *Psychologie Expérimentale*, 1839 (new edition entitled *Esprit Humain et ses Facultés*, 1859); *Philosophie Morale*, 1849; *Religion et Liberté*, 1848; *La Morale de l'Évangile comparée aux divers systèmes de Morale*, 1855.

**BAUTZEN** (in Wendish *Budissin*, which is equivalent to "town"), the capital of Saxon Upper Lusatia, occupies an eminence on the right bank of the Spree, 680 feet above the level of the sea, and 32 E.N.E. from Dresden. Lat. 51° 11' 10" N., long. 14° 25' 50" E. The town is well built and surrounded by walls, and has extensive suburbs partly lying on the left bank of the river. It has a cathedral which is used by both Protestants and Roman Catholics, and five other churches, a handsome town-house, an orphan-asylum, several hospitals, a mechanics' institute, a famous gymnasium, a normal and several other schools, and two public libraries. Its general trade and manufactures are considerable, including linen, cotton, and woollen goods, tobacco, leather, paper, saltpetre, gunpowder, &c. Population in 1871, 13,165. Bautzen was already in existence when Henry the Fowler conquered Lusatia in 928. It became a town and fortress under Otto I., his successor, and speedily attained considerable wealth and importance, for a good share of which it was indebted to the pilgrimages which were made to the "Arm of St Peter," preserved in one of the churches. It suffered greatly during the Hussite war, and still more during the Thirty Years' War, in the course of which it was besieged and captured by the Electoral Prince, John George (1620), fell into the hands of Wallenstein (1633), and was burned and taken by the Electoral Prince of Saxony. At the Peace of Prague in 1635 it passed with Lusatia to Saxony as a war indemnity. The battle of Bautzen was fought here on the 21st and 22d of May 1813, between the French under Napoleon and the allied forces of Russia and Prussia, in which, after severe losses on both sides, the latter were defeated.

## B A V A R I A

**BAVARIA** (in German, *Bayern*), a kingdom of Southern Germany, forming part of the German Empire, consists of two distinct portions, Bavaria proper and the Palatinate of the Rhine, which are separated by the grand duchies of Baden and Hesse. Bavaria proper contains an area of about 26,895 miles, and the Palatinate rather less than 2282, making the whole extent of the kingdom about 29,177 square miles.

The frontier of Bavaria proper on the north-east, towards Bohemia, consists of a long range of mountains known as the Böhmerwald; while the north is occupied by the Fichtelgebirge and the Frankenwald, which separate Bavaria from Reuss, Meiningen, and Hesse-Darmstadt. The ranges

last named seldom exceed the height of 3000 or 4000 feet; but the ridges in the south, towards the Tyrol, form part of the system of the Alps, and frequently attain an elevation of 9000 or 10,000 feet. On the west it is bounded by Würtemberg, Baden, and Hesse-Darmstadt. The whole of the country belongs to the basins of the Danube and the Main; by far the greater portion being drained by the former river, which, entering from Swabia as a navigable stream, traverses the entire breadth of the kingdom, with a winding course of 200 miles, and receives in its passage the Iller, the Lech, the Isar, and the Inn from the south, and the Naab, the Altmühl, and the Würnitz from the north. The Inn is navigable before it enters the

Bavarian territory, and afterwards receives the Salza, a large river flowing from Upper Austria. The Isar does not become navigable till it has passed Munich; and the Lech is a stream of a similar size. The Main traverses the northern regions, or Upper and Lower Franconia, with a very winding course, and greatly facilitates the trade of the provinces. The district watered by the southern tributaries of the Danube consists for the most part of an extensive plateau, with a mean elevation of 2390 feet. In the mountainous parts of the country there are numerous lakes, and in the lower portions considerable stretches of marshy ground. The climate of Bavaria differs greatly



Sketch Map of Bavaria Proper.

according to the character of the region, being cold in the vicinity of the Tyrol but warm in the plains adjoining the Danube and the Main. On the whole, the temperature is in the winter months considerably colder than that of England, and a good deal hotter during summer and autumn.

The extent of forest is more than twice that of the land under wood in Great Britain. It forms more than a fourth of the total area of Bavaria, while in Britain the proportion is less than a twenty-sixth. This is owing to various causes—the extent of hilly and mountainous country, the thinness of the population, and the necessity of keeping a given extent of ground under wood for the supply of fuel. Nearly a third of the forests are public property, and furnish a considerable addition to the revenue. They are principally situated in the provinces of Upper Bavaria, Lower Bavaria, and the Upper Palatinate. The level country, including both Lower Bavaria (extending northwards to the Danube), and the western and middle parts of Franconia, is very productive in rye, oats, wheat, barley, and millet, and also in hemp, flax, hops, madder, and (in warm situations) in vines. The last are grown chiefly in the vicinity of the Lake of Constance and on the banks of the Main, in the lower part of its course, while the most extensive hop-growing district is central Franconia. Potatoes are cultivated in all the provinces, but especially in the Palatinate and in the Spessart district, which lies in the north-west within a curve of the Main. The southern division of Swabia and Upper Bavaria, where pasture-land predominates, form a cattle-breeding district, and the dairy produce is extensive, no less than 11,000 tons of cheese and 2386 tons of butter being sold in the course of a year. The former finds a market all over Germany, and is also

exported to Austria, France, and other countries, while Northern Germany is the chief consumer of the latter. The greater proportion of the land throughout the kingdom is in the hands of peasant proprietors, the extent of the separate holdings differing very much in different districts. The largest peasant property may be about 170 English acres, and the smallest, except in the Palatinate, about 50.

According to the returns for 1863 the number of cattle in the kingdom was 3,185,688; sheep, 2,058,638; swine, 926,522; and goats, 150,855. Oxen are largely employed in agricultural operations instead of horses. The cattle, as a general rule, are kept in sheds, and not pastured in the fields.

Of mineral deposits Bavaria possesses a great variety. The quantity of iron ore is very large both in the south and north, the number of mines being between 200 and 300. Coal-mines are likewise numerous, especially in the districts of Amberg, Kissingen, Steben, Munich, and the Rhine Palatinate. The produce in 1867 was nearly 351,000 tons. Of quicksilver there are several mines, chiefly in the Palatinate of the Rhine; and small quantities of copper, manganese, and cobalt are obtained. There are numerous quarries of excellent marble, alabaster, gypsum, and building stones; and the porcelain-clay is among the finest in Europe. To these may be added graphite, emery, steatite, barytes, felspar, and ochre, in considerable quantities; excellent lithographic stone is obtained at Solnhofen; and gold and silver are still worked to an insignificant extent. Salt is annually prepared on a large scale, being obtained partly from brine springs and partly from mines. The principal localities are Halle, Berchtesgaden, Traunstein, and Rosenheim. The gross production in 1866 was 41,119 tons, and the value at the works amounted to £62,869. In the following year the Government monopoly, which had existed so long, was abolished, and free trade was established in salt between the members of the customs-union, a change which has led to a considerable import of salt from Prussia.

A great stimulus was given to manufacturing industry in Bavaria by the law of 1868, which abolished the last remains of the old restrictions of the guilds, and gave the whole country the liberty which had been enjoyed by the Rhine Palatinate alone. The chief manufacturing centres are Nuremberg and Munich for hardware, and Augsburg for cloth goods; but various other towns are rising into importance. In Franconia are numerous paper-mills, and saw-mills are naturally common in the forest districts. A considerable quantity of glass is manufactured, especially in the Böhmerwald, and wooden wares are largely produced at Ammergau and Berchtesgaden. The preparation of the favourite national drink forms an important industry—the breweries throughout the kingdom numbering upwards of 5000. Among the most remarkable are the breweries of Erlangen. Other articles of manufacture are leather, tobacco, and earthenware.

The exports from Bavaria consist chiefly of salt, timber, cattle, pigs, corn, and madder; and the imports comprise sugar, tobacco, raw cotton and cotton-goods, silks and linen, iron and iron-ware. As most of the imports are introduced indirectly through other Zollverein states, no custom-house register is kept of the total amount.

The highroads in Bavaria extend in all over 9000 miles. In 1869 there were rather more than 1600 miles of railway in operation, and nearly 300 were in course of construction. The greater proportion is in the hands of the Government, and the remainder belongs to the Eastern Company and the United Railway Companies of the Rhine, Palatinate. The principal canal in the kingdom is the Ludwigs-canal, which connects the Rhine with the Danube, extending from Bamberg on the Regnitz to Dietfurt on

the Altmühl. There is an extensive network of telegraphs, all of which belong to, and are worked by, the Government post office.

The Bavarians proper form a distinct section of the German race, speaking a well-defined dialect of the High German, but a large portion of the population of the country is of Swabian origin. The national character resembles that of the Austrians, being generally marked by fidelity and loyalty. In matters of religion they are credulous and even superstitious; and the will of their superiors is received by the lower orders with great deference both in political and ecclesiastical affairs. Independence of thought and action have, however, been gradually increasing; and now that the country has become part of the German empire, a rapid transfusion of intellectual and political life is apparently taking place.

The present form of government is founded partly on long-established usage and partly on a constitutional act, passed in May 1818, and modified by subsequent acts, of which the most important was passed in 1848-9. The monarchy is hereditary, with a legislative body of two houses. The title of the sovereign is simply king of Bavaria; that of his presumptive heir is crown-prince of Bavaria. The executive power is vested altogether in the king, whose person is declared inviolable, the responsibility rests with the ministers, whose functions are nearly the same as those of ministers in England; and there are offices for foreign affairs for the home department, for religion and education, for the treasury, the army, and the administration of justice. These are all situated in Munich, the capital. The upper house of the Bavarian parliament, known as the Chamber of the *Reichsräthe*, comprises the princes of the blood-royal, the two archbishops, the barons or heads of certain noble families, a Roman Catholic bishop and Protestant clergyman appointed by the Crown, and any other members whom the king may nominate either as hereditary peers or as counsellors for life; but these last must not exceed a third of the hereditary members. The lower house, or Chamber of Representatives (*Wahlkammer*), consists of about 150 deputies, who formerly were chosen in definite proportions from the different classes of the community, an eighth part from the nobility, another eighth from the clergy, a fourth part from the burghers, and the remaining half from the landed proprietors; but since 1848 they may be selected without any such restrictions. A general election takes place once in six years, one deputy being allowed for every 7000 families in the kingdom. The election, however, is indirect,—electoral proxies, or *Wahlmänner*, to whom the real election is entrusted, being chosen by the general body of electors at the rate of one proxy to every 500 men. The king generally convenes the parliament once a year, and by the constitution it is obligatory on him to do so at least once in three years.

The following is a statement of the budget for the year 1874-5, in marks (equal to la. sterling):—

REVENUE.		
<i>Direct Taxes.</i>	Marks.	
Land tax.....	11,438,323	
Tax on buildings.....	1,995,086	
Tax on licences.....	2,820,000	
Tax on capital.....	1,628,571	
Tax on income.....	857,143	
	18,739,123	
<i>Indirect Taxes.</i>		
Registration .....	10,889,006	
Stamp-duty .....	8,286,029	
Malt tax.....	17,727,137	
Customs.....	1,344,171	
	38,246,343	
Carry forward,		51,985,466

Brought forward, 51,985,466

<i>Royalties and State Establishments.</i>	
Mines and Salt-works.....	3,788,285
Coinage.....	248,048
Railways.....	56,281,257
Post-offices.....	7,708,261
Telegraphs.....	1,315,029
Ludwig canal.....	136,581
Sundries.....	437,773
	76,911,240
Domains.....	36,212,277
Special duties.....	55,266
Other receipts.....	598,183
Surplus of eleventh financial period.....	10,861,423
Imperial subsidy.....	34,580,760
Share of French indemnity.....	857,143
	123,878,292
Total receipts.....	212,051,868 Marks, or £10,602,593

#### DISBURSEMENTS.

Public debt.....	27,531,400
Civil list.....	5,415,470
Council of state.....	104,985
Parliamentary expenses.....	346,006
Royal household and foreign affairs.....	671,091
Justice.....	11,764,618
Home department.....	18,209,522
Treasury.....	2,359,533
Religion and education.....	18,476,318
Contribution to imperial funds.....	14,747,691
Army.....	24,580,760
Pensions to widows and orphans.....	1,689,771
Reserve fund.....	899,409
	126,846,594
Total.....	126,846,594
Expenses of administration.....	75,205,274
	212,051,868 Marks, or £10,602,593

The Bavarian army forms, since the 23d November 1870, a separate portion of the army of the German empire, with a distinct administration; but its organization is subject to the general imperial rules, and in time of war it is placed under the command of the emperor. It comprises two *corps d'armée*, each divided into two divisions. In time of peace its infantry consists of 26,590 men, distributed in sixteen regiments; besides which there are ten battalions of *chasseurs*, 5500 strong, and thirty-two battalions of *landwehr*; the cavalry numbers 7200 men divided into ten regiments, and the artillery amounts to 5528 men in six regiments; there are also two battalions of pioneers and as many of the military train. In time of war the total force is raised to 149,892, or rather more than trebled.

The districts of Lower Bavaria, Upper Bavaria, and the Upper Palatinate are almost wholly Catholic, while in the Rhine Palatinate, Upper Franconia, and especially Middle Franconia, the preponderance is on the side of the Protestants. The exercise of religious worship in Bavaria is altogether free. The Protestants have the same civil rights as the Catholics, and the sovereign may be either Catholic or Protestant. Of the Roman Catholic Church the heads are the two archbishops of Munich-Freising and Bamberg, and the six bishops of Eichstätt, Spire, Würzburg, Augsburg, Regensburg, and Passau, of whom the first three are suffragans of Bamberg. The "Old Catholic" party has recently taken considerable hold of the country, and has organized congregations in all the more important towns. Among the Protestants the highest authority is the general consistory of Munich. The proportion of the different religions in 1871 was as follows:—Roman Catholics, 3,464,364; Protestants, 1,342,592; Jews, 50,662; lesser Christian sects, 5453; other religions, 379.

Bavaria was formerly as backward in regard to clus-



tion as Austria, or any part of the south of Germany; but latterly considerable efforts have been made to lessen the prevailing ignorance. At Munich there are scientific and literary academies, as well as a university, a lyceum, a gymnasium, and other public schools. The university has a very numerous attendance of students, ranking third in the new German empire; and there are two provincial universities on a small scale, one (Catholic) at Würzburg, the other (Protestant) at Erlangen in Franconia. In the kingdom at large there are ten lycæums, twenty-eight gymnasia, about sixty progymnasia, besides ten normal, twenty-six trade, three polytechnic, and upwards of 7000 common schools. These certainly form a great contrast to the indifference and neglect of former times; and the Government continues to evince much solicitude for the diffusion of instruction. Technical schools here, as in other parts of Germany, have been established for the purpose of affording to mechanics more suitable education than they could otherwise obtain, including mathematics, mechanics, drawing, chemistry, architecture, &c. These schools are supported by the commune, aided when necessary by the province, and commissioners are annually sent by Government to examine and report upon them to the minister of trade. The course extends over three years, from the age of twelve to fifteen, after which pupils may enter one of three polytechnic schools, where a still higher course of instruction is imparted, also extending over three years; but engineers have a special fourth year's course. A building school was established at Munich in 1823, and is chiefly intended for carpenters and masons, who are there instructed in architecture, drawing, geometry, stone-cutting, modelling ornaments, &c.

The duchy of Bavaria during the Middle Ages consisted of the southern half of the present kingdom, and lay almost all to the south of the Danube, extending about 100 miles from that river to the Tyrol, and somewhat more from Swabia on the west to Austria on the east. The addition in 1623 of the Upper Palatinate, a province of full 3000 square miles, to the north of the Danube, gave the elector a territory of about 15,000 square miles, with a population of less than 1,000,000, which in a century and a half had increased to about 1,500,000. In 1778 the succession of the Rhenish branch of the reigning family added the Palatinate of the Rhine, and in 1806 a large augmentation was effected by Napoleon, who presented the king with the districts of the Lower Main and the Rezat, and with part of those of the Upper Main and the Upper Danube; not to mention Tyrol, which was afterwards restored to Austria. Some slight changes have taken place in the extent of the kingdom since then; but its general character has not been affected. The most important cession of recent years was that of part of Franconia in 1866 to Prussia, amounting to 291 square miles, with a population of 32,976 inhabitants. The following table gives the present and former division of the kingdom and its population in 1818, 1846, and 1871 respectively:—

Old Circles.	New Circles.	Area in Eng. Miles.	Population.		
			1818.	1846.	1871.
Isar	Upper Bavaria	6556	585,467	705,544	841,707
Lower Danube	Lower Bavaria	4141	450,895	543,709	603,789
Regen	Upper Palatinate	3717	403,481	467,606	497,361
Upper Main	Upper Franconia	2692	394,954	501,163	541,063
Rezat	Middle "	2906	437,838	527,866	583,666
Lower Main	Lower "	3230	501,212	592,080	586,132
Upper Danube	Swabia	3651	487,951	558,436	532,773
Rhine	Rhine Palatinat	2232	446,163	608,470	615,036

The total population in 1871, including the troops then absent in France, amounted to 4,363,450. The density

of population varies considerably in the different districts from about 273 inhabitants to the square mile in the Palatinate to 128 in Upper Bavaria. As represented by the increase of each successive census the growth of the population is rather slow, but a large amount of emigration to America and elsewhere has to be taken into account. A very considerable number of the people are urban, as may be seen from the following list of principal towns (arranged in the order of the circles) with their populations:—

Upper Bavaria	Munich (capital)	169,693
	Ingolstadt	13,157
	Landshut	14,140
Lower Bavaria	Passau	13,379
	Straubing	11,150
	Ratisbon (or Regensburg)	29,185
Upper Palatinate	Amberg	11,688
	Bamberg	25,738
	Bayreuth	17,541
Upper Franconia	Hof	16,010
	Nuremberg	83,214
	Fürth	24,577
Middle Franconia	Ansbach	12,436
	Erlangen	12,510
	Würzburg	40,005
Lower Franconia	Schweinfurt	10,325
	Aschaffenburg	9,212
	Angsburg	51,220
Swabia	Kempten	11,223
	Kaiserlautern	17,896
	Spire	18,223
Palatinate of Rhine	Neustadt	9,320

The name in German, *Bayern*, or *Baiern*, is derived, like Latin *Boiaria*, from *Boii*, the name of a Celtic people by whom the country, which then formed part of Rætia, Vindalicia, and Noricum, was inhabited in the time of Augustus. After the fall of the Roman power the natives were governed by chieftains of their own till the era of Charlemagne, who subjugated this as well as most other parts of Germany. After his death Bavaria was governed by one of his grandsons, whose successors bore the title of Margrave, or Lord of the Marches. In the year 920 the ruling margrave was raised to the rank of duke, which continued the title of his successors for no less than seven centuries. During this period Bavaria was connected with Germany nationally by language and politically as a frontier province, but in civilization was almost as backward as Austria, and was greatly behind Saxony, Franconia, and the banks of the Rhine. At last, in 1620, the reigning duke, having rendered great service to Austria against an insurrection in Bohemia, received an important accession of territory at the expense of the Elector Palatine, and was appointed one of the nine electors of the empire. His successors continued faithful members of the Germanic body and allies of Austria until 1771, when the elector Max Emanuel began to assist Louis XIV. of France by threatening and attacking Austria, so as to prevent her from co-operating efficiently with England and Holland. This induced the duke of Marlborough, in the spring of 1704, to march his army above 300 miles from the banks of the Meuse to invade Bavaria, the fate of which was decided by the battle of Blenheim on the 13th August 1704. For ten years from this date the elector and his remaining forces served in the French armies, and his country was governed by imperial commission until the peace of Utrecht, or more properly that of Baden, in 1714, reinstated him in his dominions.

His son Charles Albert, who succeeded him in 1726, untaught by these disasters, renewed his connection with France; and, in 1740, on the death of the emperor of Germany, came forward as a candidate for the imperial crown. He obtained the nomination of a majority of the electors, and overran a considerable part of the Austrian territory; but his triumph was of short duration, for the arms of Maria Theresa not only repulsed the Bavarians,

but obtained in 1741 possession of the electorate. The elector died soon after, and his son Maximilian Joseph recovered his dominions only by renouncing the pretensions of his father.

Bavaria now remained tranquil above thirty years, until 1777, when, by the death of Maximilian, the younger line of the house of Wittelsbach, the line which had long ruled in Bavaria, became extinct. The next heir was Charles Theodore the Elector Palatine, the representative of the elder line of Wittelsbach; but Austria unexpectedly laid claim to the succession, and took military possession of part of the country. This called into the field, on the side of Bavaria, Frederic II. of Prussia, then advanced in years; but, before any blood had been shed, Austria desisted from her pretensions, on obtaining from Bavaria the frontier district which bears the name of Innviertel, or the Quarter of the Inn.

Bavaria again remained at peace until the great contest between Germany and France began in 1793, when she was obliged to furnish her contingent as a member of the empire. During three years her territory was untouched; but in the summer of 1796, a powerful French army under Moreau occupied her capital, forced her to sign a separate treaty with France, and to withdraw her contingent from the imperial army. The next war between France and Austria, begun in 1799, ending disastrously for the latter, the influence of France in the empire was greatly strengthened, so that, when the Austrians once more took up arms, in 1805, Bavaria was the firm ally of France, and for the first time found advantage in the connection,—its elector, Maximilian Joseph, receiving from Napoleon the title of king and several additions of territory.

Bavaria continued to support the French interest with her best energies till 1813, when, on condition of her late acquisitions being secured to her, she was led to join the Allies, and her forces contributed largely to the ultimate defeat of Bonaparte. In 1818 Maximilian presented his country with a constitution, of rather a mixed character, in which an attempt was made at once to satisfy the growing desire for political liberty and to maintain the kingly power. At the same time several beneficial measures, such as the abolition of serfdom, were effected in the earlier sessions of the new parliament. In 1825 Maximilian was succeeded by his son Louis, who distinguished himself as a promoter of the fine arts, but proved himself destitute of political capacity, and in consciousness

of his disagreement with the spirit of his times, abdicated in March 1848 in favour of his son Maximilian II. It was not long before the difficulties of the new king were distinctly brought to view by the insurrection of the democratic party in Westphalia. By the assistance of Prussia the rising was quelled, and punishment was so ruthlessly inflicted by the tribunals that the trials became known as the bloody assizes. An anti-liberal reaction set in, and many of the political gains of former years were consequently lost. In 1864 King Louis was succeeded by his son of the same name (Louis II.); and at this time the great question on the future hegemony of Germany was being agitated throughout the country. In the war of 1866 the Bavarian Government and people threw in their lot with Austria, shared in the contest, and were involved in the defeat and loss. On the withdrawal of Austria from the German confederation a change of policy was introduced, and the Government veered round to the interests of Prussia, a course which was confirmed by the Franco-German War of 1870, when Bavaria took an active part with Prussia against the common enemy. Much ferment, however, remained in the country, and religious elements were introduced into the political discussions. The clerical, or, as it styles itself, the patriot party, is opposed to Prussian influence, and contends for "particularism," wishing to maintain a greater degree of independence for Bavaria than seems to be compatible with imperial unity. For a number of years the Government has been in the hands of the Liberal party. Thus a series of the most important measures have been passed with a liberal tendency, and the country is being gradually assimilated to the more advanced states of Northern Germany. The focus of the Liberal party is the Palatinate of the Rhine, while the "patriots" are mainly recruited from the districts of Old Bavaria. The decisive triumph of the former was marked by the treaty of November 23, 1870, between Bavaria and the Confederation of Northern Germany, which was followed by the recognition of the king of Prussia as the head of a new German empire. At the same time a greater degree of independence was granted to Bavaria than to the other members of the Confederation; it was freed from the domiciliary surveillance of the empire, and allowed to retain the administration of its own postal and telegraph systems, while its army has a separate organization, and during peace is under the command of the Bavarian king.

**BAXAR, or BUKAR,** a town of Hindustán, in the province of Behar, district of Sháhábád, on the south bank of the Ganges, in 25° 32' N. lat., 84° 3' E. long. The fort, though of small size, was important from its commanding the Ganges, but is now dismantled. The place is distinguished by a celebrated victory gained on the 23d October 1764 by the British forces under Major (afterwards Sir Hector) Munro, over the united armies of Sujá-ud-Daulah and Kasim Ali Khán. The action raged from 9 o'clock till noon, when the enemy gave way. Pursuit was, however, frustrated by Sujá-ud-Daulah sacrificing a part of his army to the safety of the remainder. A bridge of boats had been constructed over a stream about 2 miles distant from the field of battle, and this the enemy destroyed before their rear had passed over. Through this act 2000 troops were drowned, or otherwise lost; but destructive as was this proceeding, it was, says Major Munro, "the best piece of generalship Sujá-ud-Daulah showed that day, because if I had crossed the rivulet with the army, I should either have taken or drowned his whole army in the Karamnáá, and come up with his treasure and jewels, and Kasim Ali

Khán's jewels which I was informed amounted to between two and three millions." Population in 1872, 13,446.

**BAXTER, ANDREW,** an able metaphysician, the son of a merchant in Old Aberdeen, was born in 1686 or 1687, and educated at King's College there. After leaving the university he acted for some years as tutor to various young gentlemen, among others to Lord Gray, Lord Blantyre, and Mr Hay of Drummelzier. In 1733 he published, in quarto, but without date, *An Inquiry into the Nature of the Human Soul*, wherein its immateriality is deduced from the principles of reason and philosophy. In 1741 he went abroad with Mr Hay, and resided several years at Utrecht, from which place he made excursions into Flanders, France, and Germany. He returned to Scotland in 1747, and resided at Whittingham, in Haddingtonshire, till his death, which occurred on April 23, 1750. His principal work, besides the *Inquiry*, was a short dialogue entitled *Matha, sive Cosmotheoria puerilis, Dialogus in quo prima elementa de mundi ordine et ornatu proponuntur, &c.* This was afterwards greatly enlarged, and published in English in two volumes 8vo. In 1750 was published an appendix to

his *Inquiry into the Nature of the Human Soul*, in which he endeavoured to remove some difficulties which had been started against his notions of the *vis inertia* of matter, by Maclaurin, in his *Account of Sir Isaac Newton's Philosophical Discoveries*. To this Baxter prefixed a dedication to John Wilkes, with whom he had formed acquaintance abroad. The *Inquiry* is a work of no small ability. The author begins by examining, after the principles of the Newtonian philosophy, the properties of matter. All, save one, result from forces which act on matter. The one essential property of matter is its inactivity, *vis inertia*, or resistance to motion. From this single fact it at once follows that all action or movement must be the effect of some immaterial cause, i.e., of God. The spontaneous motions of the body are not of the same kind as the mechanical movements of the external universe, and are accordingly to be ascribed to a special immaterial force, or spirit, the soul. From the immateriality of the soul its immortality is, of course, deduced. Nor does the conscious existence of the soul depend upon that of the body; it lives after death. Baxter supports his argument by a long analysis of the phenomena of dreams, which he ascribes to direct spiritual influence, and finally attempts to prove that matter is not eternal. A second edition of the *Inquiry* was published in 1737, and a third in 1745.

BAXTER, RICHARD, one of the most eminent of English divines, styled by Dean Stanley "the chief of English Protestant Schoolmen," was born at Rowton in Shropshire, at the house of his maternal grandfather, on November 12, 1615. His family connections were favourable to the growth of piety. But his early education was much neglected, and he did not study at any university, a circumstance worthy of notice, considering the eminent learning to which he afterwards attained. His best instructor was a Mr John Owen, master of the Free School at Wroxeter. His diligence in the acquirement of knowledge was remarkable; and from the first he had a strong bent towards the philosophy with which religion is concerned.—Mr Francis Garbot of Wroxeter being the director of these studies. For a short time his attention was turned to a court life, and he went to London under the patronage of Sir Henry Herbert, master of the revels, to follow that course; but he very soon returned home with a fixed resolve to cultivate the pursuit of divinity. Practical rather than speculative theology seems to have occupied his mind, and he therefore presented himself for ordination without any careful examination of the Church of England system. He was nominated to the mastership of the Free Grammar School, Dudley, in which place he commenced his ministry, having been ordained and licensed by Thornborough, bishop of Worcester. His popularity as a preacher was, at this early period, very great; and he was soon transferred to Bridgnorth, where, as assistant to a Mr Madstard, he established a reputation for the vigorous discharge of the duties of his office.

During this time he took a special interest in the controversy relating to Nonconformity and the English Church. He soon, on some points, became alienated from the Church; and after the requirement of what is called "the *et cetera* oath," he rejected Episcopacy in its English form. He could not, however, be called more than a moderate Nonconformist; and such he continued to be throughout his life. Though commonly denominated a Presbyterian, he had no exclusive attachment to Presbyterianism, and often manifested a willingness to accept a modified Episcopalianism. All forms of church government were regarded by him as subservient to the true purposes of religion.

One of the first measures of the Long Parliament was to effect the reformation of the clergy; and, with this view,

a committee was appointed to receive complaints against them. Among the complainants were the inhabitants of Kidderminster, a town which had become famous for its ignorance and depravity. This state of matters was so clearly proved that an arrangement was agreed to on the part of the vicar, by which he allowed £60 a year, out of his income of £200, to a preacher who should be chosen by certain trustees. Baxter was invited to deliver a sermon before the people, and was unanimously elected as the minister of the place. This happened in 1641, when he was twenty-six years of age.

His ministry continued, with very considerable interruptions, for about nineteen years; and during that time he accomplished a work of reformation in Kidderminster and the neighbourhood which is as notable as anything of the same kind upon record. Civilized behaviour succeeded to brutality of manners; and, whereas the professors of religion had been but small exceptions to the mass, the unreligious people became the exceptions in their turn. He formed the ministers in the country around him into an association for the better fulfilment of the duties of their calling, uniting them together irrespective of their differences as Presbyterians, Episcopalians, and Independents. The spirit in which he acted may be judged of from *The Reformed Pastor*, a book published in relation to the general ministerial efforts he promoted. It drives home the sense of clerical responsibility with extraordinary power. The result of his action is that, to this day his memory is cherished as that of the true apostle of the district where he laboured.

The interruptions to which his Kidderminster life was subjected arose from the condition of things occasioned by the Civil War. Worcestershire was a cavalier county, and a man in Baxter's position was, while the war continued, exposed to annoyance and danger in a place like Kidderminster. He therefore removed to Gloucester, and afterwards settled in Coventry, where he for the most part remained about two years, preaching regularly both to the garrison and the citizens. After the battle of Naseby he took the situation of chaplain to Colonel Whalley's regiment, and continued to hold it till February 1647.

His connection with the Parliamentary army was a very characteristic one. He joined it that he might, if possible, counteract the growth of the sectaries in that field, and maintain the cause of constitutional government in opposition to the republican tendencies of the time. He regretted that he had not previously accepted an offer of Cromwell to become chaplain to the Ironsides, being confident in his power of persuasion under the most difficult circumstances. His success in converting the soldiery to his views does not seem to have been very great, but he preserved his own consistency and fidelity in a remarkable degree. By public disputation and private conference, as well as by preaching, he enforced his doctrines, both ecclesiastical and political, and shrank no more from urging what he conceived to be the truth upon the most powerful officers than he did from instructing the meanest followers of the camp. Cromwell shunned his society; but Baxter having to preach before him after he had assumed the Protectorship, chose for his subject the old topic of the divisions and distractions of the church, and in subsequent interviews not only opposed him about liberty of conscience, but spoke in favour of the monarchy he had subverted. There is a striking proof of Baxter's insight into character in his account of what happened under these circumstances. Of Cromwell he says, "I saw that what he learned must be from himself." It is worthy of notice that this intercourse with Cromwell occurred when Baxter was summoned to London to assist in settling "the fundamentals of religion," and made the memorable declaration in answer to the objection, that

what he had proposed as fundamental "might be subscribed by a Papist or Socinian." "So much the better," was Baxter's reply, "and so much the fitter it is to be the matter of concord."

After the Restoration in 1660 Baxter settled in London. He preached there till the Ejectment Act took effect in 1662, and was employed in seeking for such terms of comprehension as would have permitted the moderate dissenters with whom he acted to have remained in the Church of England. In this hope he was sadly disappointed. There was at that time on the part of the rulers of the church no wish for such comprehension, and their object, in the negotiations that took place, was to excuse the breach of faith which their rejection of all reasonable methods of concession involved. The chief good that resulted from the Savoy Conference was the production of Baxter's *Reformed Liturgy*, a work of remarkable excellence, though it was cast aside without consideration. The same kind of reputation which Baxter had obtained in the country he secured in the larger and more important circles of the metropolis. The power of his preaching was universally felt, and his capacity for business placed him at the head of his party. That he should have been compelled by the activity of party spirit to remain outside the National Church is to be deeply regretted. He had, indeed, been made a king's chaplain, and was offered the bishopric of Hereford, but he could not accept the offer without virtually assenting to things as they were; after his refusal he was not allowed, even before the passing of the Act of Uniformity, to be a curate in Kidderminster, though he was willing to serve that office gratuitously. Bishop Morley even prohibited him from preaching in the diocese of Worcester. The whole case illustrates afresh the vindictive bitterness of ecclesiastical factions in the heat of party contests, and especially in the hour of secular triumph.

From the Ejectment of 1662 to the Indulgence of 1687, Baxter's life was constantly disturbed by persecution of one kind or another. He retired to Acton in Middlesex, for the purpose of quiet study, and was dragged thence to prison on an illegal accusation of keeping a conventicle. He was taken up for preaching in London after the licences granted in 1672 were recalled by the king. The meeting-house which he had built for himself in Oxendon Street was closed against him after he had preached there but once. He was, in 1680, seized in his house, and conveyed away at the risk of his life; and though he was released that he might die at home, his books and goods were distrained. He was in 1684 carried three times to the sessions' house, being scarcely able to stand, and without any apparent cause was made to enter into a bond for £400 in security for his good behaviour.

But his worst encounter was with Judge Jeffreys in May 1685. He had been committed to the King's Bench Prison for his *Paraphrase on the New Testament*, which was ridiculously attempted to be turned into a seditious book, and was tried before Jeffreys on this accusation. The scene of the trial is well known as among the most brutal perversions of justice which have occurred in England. Jeffreys himself acted like an infuriated madman; but there were among his blackguardisms some sparks of intelligence.

Mr Rotherham, one of his counsel, said that Baxter frequently attended divine service, went to the sacrament, and persuaded others to do so too, as was certainly and publicly known; and had, in the book charged against him, spoken very moderately and honourably of the bishops of the Church of England. "Baxter for bishops!" Jeffreys exclaimed, "that's a merry conceit indeed; turn to it, turn to it." Upon this, Rotherham read out:—"That great respect is due to those truly called to be bishops among us, or to that purpose. "Ay," said Jeffreys, "this is your Presbyterian cant—truly called to be bishops—that is himself and such rascals, called to be bishops of Kidderminster and other such places, bishops set

apart by such factions, unravelling Presbyterians as himself. A Kidderminster bishop he means."

That was sharp, however coarse; for, putting the case vulgarly, it was "a Kidderminster bishop" that Baxter meant. He was sentenced to pay 500 marks, to lie in prison till the money was paid, and to be bound to his good behaviour for seven years. It was even asserted at the time that Jeffreys proposed he should be whipped at the cart's tail through London. The old man, for he was now seventy, remained in prison for two years.

During the long time of oppression and injury which followed the Ejectment, Baxter was sadly afflicted in body. His whole life was indeed one continued disease, but in this part of it his pain and languor had greatly increased. Yet this was the period of his greatest activity as a writer. He was a most voluminous author, his separate works, it is said, amounting to 168. A considerable proportion of these, including folios and quartos of the most solid description, were published by him while thus deprived of the common rights of citizenship. How he composed them is matter of wonder. They are as learned as they are elaborate, and as varied in their subject as they are faithfully composed. Such treatises as the *Christian Directory*, the *Methodus Theologia Christiana*, and the *Catholic Theology*, might each have occupied the principal part of the life of an ordinary man. One earthly consolation he had in all his troubles; he was attended upon by a loving and faithful wife, whom he had married in the Ejectment year. She was much younger than himself, and had been brought up as a lady of wealth and station; but she adhered to him in all his wanderings, sharing his sufferings, and following him to prison; and she has her reward in that *Breviate of the Life of Mrs Margaret Baxter*, which, while it records her virtues, reveals on the part of her husband a tenderness of nature which might otherwise have been unknown.

The remainder of Baxter's life, from 1687 onwards, was passed in peace and honour. He continued to preach and to publish almost to the end. He was surrounded by attached friends, and revered by the religious world. His saintly behaviour, his great talents, and his wide influence, added to his extended age, raised him to a position of unequalled reputation. He died in London on the 8th of December 1691, being seventy-six years old, and was buried in Christ Church. His funeral was attended by a very large concourse of people of all ranks and professions, including churchmen as well as dissenters. A similar tribute of general esteem was paid to him nearly two centuries later, when a statue was erected to his memory at Kidderminster in July 1875. On that occasion clergy of all denominations, among whom the bishop of Worcester and the dean of Westminster were conspicuous, took part in the proceedings.

There are few persons of whom we can form a more distinct conception than we can of Richard Baxter. His face is quite familiar to us. His thin and stooping figure we seem to have seen. We can imagine the glance of his piercing eye. Who has not smiled at the intensity of his argumentative nature? He thought every one was amenable to reason—bishops and levellers included. See him contending with the military secretaries in the church at Chesham, from morning to night, when "he took the reading-pew, and Pichford's cornet and troopers took the gallery." Follow him, undeterred by his former want of success, to the church at Bewdley, where he disputed all day with Mr Tombs about infant baptism. Read his correspondence with Dr John Owen relative to the union of Presbyterians with Independents, in which his eagerness amusingly contrasts with Owen's hesitation. Watch him hour after hour in hand-to-hand controversy with Dr

Gunning at the Savoy Conference, when all the town looked at them as at two boxers in a ring. These are but specimens of other like exhibitions. And yet he was as far as possible from being a quarrelsome man. It was in charity for his opponents that he fought. His pertinacity in contention was the fruit of the sincerity of his aims. He must have been a delightful companion to those who shared his religious or scholastic sympathies. How pleasant and profitable it would have been to witness the intimate intercourse at Acton between him and Sir Matthew Hale! He was at once a man of fixed belief and large appreciation, so that his dogmatism and his liberality sometimes came into collision. There was a universality in his genius which distinguishes him from most other men. His popularity as a preacher was deservedly pre-eminent; but no more diligent student ever shut himself up with his books. He was singularly fitted for intellectual debate, but his devotional tendency was equally strong with his logical aptitude. Some of his writings, from their metaphysical subtlety, will always puzzle the learned; but he could write to the level of the common heart without loss of dignity or pointedness. His *Reasons for the Christian Religion* is still, for its evidential purpose, better than most works of its class. His *Poor Man's Family Book* is a manual that continues to be worthy of its title. His *Saints' Everlasting Rest* will always command the grateful admiration of pious readers. Perhaps no thinker has exerted so great an influence upon Nonconformity as Baxter has done, and that not in one direction only, but in every form of development, doctrinal, ecclesiastical, and practical. He is the type of a distinct class of the Christian ministry,—that class which aspires after scholarly training, prefers a broad to a sectarian theology, and adheres to rational methods of religious investigation and appeal. The rational element in him was very strong. He had a settled hatred to fanaticism. Even Quakerism he could scarcely endure. An infusion of ideal sentiment would have been beneficial to the conduct of his life, as well as to his expositions of truth. The ministers of whom he was the type are to be found in all divisions of the Christian church, but with characteristic modifications. Sometimes their rationalism is most distinctive, sometimes their learning, sometimes their sympathetic feeling. But Baxter excels most of the men he thus represents in his union of those qualities, as well as in the intense sense of religion by which he was actuated. Religion was with him all and in all,—that by which all besides was measured, and to whose interests all else was subordinated.

A good *Life of Baxter*, by the Rev. William Orme, was prefixed to his *Practical Works* (published in 23 volumes); Dr Calamy abridged his *Life and Times*. The abridgment forms the first volume of the account of the ejected ministers, but whoever refers to it should also acquaint himself with the reply to the accusations which had been brought against Baxter, and which will be found in the second volume of Calamy's *Continuation*. Sir James Stephen's interesting paper on Baxter, contributed originally to the *Edinburgh Review*, is reprinted in the second volume of his *Essays*. The best recent estimates of Baxter are those given by Principal Tulloch in his *English Puritanism and its Leaders*, and by Dean Stanley in his address at the inauguration of the statue to Baxter at Kidderminster. But most valuable of all is Baxter's autobiography, called *Reliquiæ Baxterianæ*, or *Mr Richard Baxter's Narrative of the most memorable Passages of his Life and Times*. It is almost as real as a personal knowledge of its subject could have been. The account he gives at the end of Part I. of the spiritual changes he had undergone will never cease to be regarded as a rare and profoundly

interesting instance of faithful self-knowledge, and it has served the cause of Christian charity more, probably, than any treatise ever written on the subject.

There are two testimonies to Baxter's worth which, though they have frequently been quoted, cannot be omitted from any fair notice of him. Dr Barrow said that "his practical writings were never mended, and his controversial ones seldom confuted," and Bishop Wilkins asserted that "if he had lived in the primitive time he had been one of the fathers of the church."

BAYARD, PIERRE DU TERRAIL, CHEVALIER DE, was born, of a noble family, at the chateau Bayard, Dauphiné, in 1476. He served as a page to the duke of Savoy until Charles VIII., attracted by his graceful bearing, placed him among the royal followers under the count de Ligny. As a youth he was distinguished for comeliness, affability of manner, and skill in the tilt-yard. In 1494 he accompanied Charles VIII. into Italy, and was knighted after the battle of Fornova, where he had captured a standard. Shortly afterwards, entering Milan alone in pursuit of the enemy, he was taken prisoner, but was set free without a ransom by Ludovic Sforza. His powers and daring were conspicuous in the Italian wars of this period. On one occasion it is said that, single-handed, he made good the defence of a bridge over the Garigliano against about 200 Spaniards, an exploit that brought him such renown that Pope Julius II. sought to entice him into the Papal service, but unsuccessfully. The captaincy of a company in the royal service was given him in 1508, and the following year he led a storming party at the siege of Brescia. Here his intrepidity in first mounting the rampart cost him a severe wound, which obliged his soldiers to carry him into a neighbouring house, the residence of a nobleman, whose wife and daughters he protected from threatened insult. On his recovery he declined a gift of 2500 ducats, with which they sought to reward him. At this time his general was the celebrated Gaston de Foix, who acted greatly in accordance with his advice, and, indeed, fell at the battle of Ravenna through neglecting it. In 1513, when Henry VIII. of England routed the French at the battle of the Spurs, Bayard, in trying to rally his countrymen, found his escape cut off. Suddenly riding up to an English officer who was resting unarmed, he summoned him to yield, and the knight complying, Bayard in return gave himself up to his prisoner. He was taken into the English camp, but on relating this gallant incident was immediately set free by the king without ransom. On the accession of Francis I. in 1515 he was made lieutenant-general of Dauphiné; and after the victory of Marignano, to which his valour largely contributed, he had the honour of conferring knighthood on his youthful sovereign. When war again broke out between Francis I. and Charles V., Bayard, with 1000 men, held Mézières, a town which had been declared untenable, against an army of 35,000, and after six weeks compelled Nassau to raise the siege. This stubborn resistance saved Central France from invasion, as the king had not then sufficient forces to withstand the imperialists. All France rang with the achievement. Parliament thanked Bayard as the saviour of his country; the king made him a knight of the order of St Michael, and commander in his own name of 100 gens d'armes, an honour till then reserved for princes of the blood. After allaying a revolt at Genoa, and striving with the greatest assiduity to check a pestilence in Dauphiné, Bayard was sent, in 1523, into Italy with Admiral Bonivet, who, being defeated at Rebec, implored him to assume the command and save the army. He repulsed the foremost pursuers, but in guarding the rear at the passage of the Sesia was mortally wounded. He had himself placed against a tree that he might die facing the

enemy, and to Bourbon, who came up and expressed pity for him, he replied, "My lord, I thank you, but pity is not for me, who die a true man, serving my king; pity is for you who bear arms against your prince, your country, and your oath." He expired after repeating the *Miserere*. His body was restored to his friends and interred near Grenoble. Chivalry, deprived of fantastic extravagance, is perfectly mirrored in the character of Bayard. He combined the merits of a skilful tactician with the romantic heroism, piety, and magnanimity of the ideal knight-errant. Even adversaries experienced the fascination of his virtues, and joined in the sentiment that he was, as his contemporaries called him, "Le chevalier sans peur et sans reproche." (*Cf. Walford's Chevalier Bayard.*)

**BAYAZID**, or **BAJAZID**, a city of Turkish Armenia, in the pashalic of Erzeroum, 50 miles S.S.W. of Erivan, situated on the side of a rugged mountain that forms, as it were, a bastion of the Ala-dagh chain. It contains two churches, three mosques, and a monastery, that of Kara Killeessa, which is famous for the beauty of its architecture, as well as for its antiquity and grandeur. The summit of the mountain is occupied by the ruinous *Ak Seraf*, or palace, which was built by Mahmoud Pasha. The Pasha's tomb, a work of considerable richness, is in the neighbouring mosque. The position of the town, on the frontiers of Turkey and Persia and on the high road between Armenia and Azerbaijan, gives it a certain importance. It was captured by the Russians in 1828 and again in 1854, when they destroyed the fortifications on their departure. The population, which has decreased greatly within the last forty years, now numbers about 5000. Long. 43° 26' E., lat. 39° 24' N.

**BAYEUX**, formerly the capital of the Bessin, and now the chief town of an arrondissement in the department of Calvados, in France. It is situated in a fruitful valley on the River Aure, 17 miles W.N.W. of Caen. Many of its houses are of considerable antiquity, especially in the Rue St Malo and Rue St Nicholas, one in the former street being a fine specimen of the woodwork of the 15th century. The cathedral is a majestic edifice for the most part of the 12th century, though the crypt probably dates from the time of Odo (1047). There are said to be no fewer than 2976 capitals in its construction, all sculptured differently. Bayeux is the seat of a bishopric, and has tribunals of primary jurisdiction and commerce, a communal college, and an extensive library. The former episcopal palace is now the town-house, and the seminary is turned into barracks. The chief manufactures are linen and cotton goods, hosiery, lace, and pottery. Important fairs are held for the sale of horses and cattle. Under the Romans the town bore the name of Augustodurus, and was the seat of a military establishment. During the Middle Ages it was frequently burnt, and passed from one lordship to another till it was incorporated in the duchy of Normandy. Nothing, perhaps, has done more for its fame than the possession of the Norman tapestry, which is now deposited in the town-house. It consists of a strip of linen 200 feet long by 20 inches wide, worked in coloured worsted, and contains fifty-eight distinct scenes connected with the life of William the Conqueror. Seven colours only are employed, dark and light blue, red, yellow, buff, and dark and light green. In spite of the doubts that have been cast on the date of this tapestry, it seems almost certain that it is contemporaneous with the events it depicts, and it may even possibly be, as tradition would have it, the work of Queen Matilda herself. (See Bruce's *Bayeux Tapestry*, 4to, 1855; Freeman's *Norman Conquest*; Macquoid's *Through Normandy*, 1874.)

**BAYLE, PIERRE**, author of the famous *Historical and Critical Dictionary*, was born on the 18th November 1647,

at Carlat-le-Comte, near Foix, in the south of France. He was educated at first by his father, a Calvinist minister, and was afterwards sent to an academy at Puy-Laurens, where he studied with such assiduity as seriously to injure his health. After a short residence at home he entered a Jesuit college at Toulouse. While there he devoted much of his time to controversial works on theology, and ended by abjuring Calvinism and embracing the Roman Catholic faith. In this, however, he continued only seventeen months, abruptly resuming his former religion. To avoid the punishment inflicted on such as relapsed from the Catholic Church, he withdrew to Geneva, where he resumed his studies, and for the first time became acquainted with the philosophical writings of Descartes. For some years he acted as tutor in various families; but in 1675, when a vacancy occurred in the chair of philosophy at the Protestant university of Sedan, he was prevailed upon to compete for the post, and was successful. In 1681 the university at Sedan was suppressed, but almost immediately afterwards Bayle was appointed professor of philosophy and history at Rotterdam. Here in 1682 he published his famous letter on comets, and his critique of Maimbourg's work on the history of Calvinism. The great reputation achieved by this critique stirred up the envy of Bayle's colleague, Jurieu, who had written a book on the same subject, and who afterwards did all in his power to injure his former friend. In 1684 Bayle began the publication of his *Nouvelles de la République des Lettres*, a kind of journal of literary criticism, which was continued with great success for several years. In 1690 appeared a work entitled *Avis aux Réfugiés*, which Jurieu attributed to Bayle, whom he attacked with the bitterest animosity. After a long quarrel Bayle was deprived of his chair in 1693. He was not much depressed by this misfortune, being at the time closely engaged in the preparation of his great Dictionary, which appeared in 1697. A second edition was called for in 1702. The few remaining years of Bayle's life were devoted to miscellaneous writings, arising in many instances out of criticisms made upon his Dictionary. He died on the 28th December 1706, after some months' suffering from chest disease, which he would not permit to interfere with his literary labours. Bayle's erudition, despite the low estimate placed upon it by Leclerc, seems to have been very considerable. He was an ardent student, and his reading was varied and extensive. As a critic he was second to none in his own time, and even yet one can admire the lightness and delicacy of his touch, and the skill with which he handles his subject. The *Nouvelles de la République des Lettres* was the first thorough-going attempt to popularize literature, and it was eminently successful. The Dictionary, however, is Bayle's master-piece, and in it appear to perfection his various qualities,—extensive and curious information, fluency of style, and that light sceptical spirit, which has become closely associated with his name. Bayle's scepticism is of a peculiar kind. It is not a distrust of the power of human knowledge grounded on a scientific investigation of the nature of thought in itself. It is rather the scepticism of the literary man of the world, who in his reading has encountered so many opposing and well-supported arguments on all subjects, that he feels inclined to hold that no certainty can ever be attained. On this account, perhaps, his sceptical criticism, though it did much to liberate thought from the bonds of authority, has had little influence on pure philosophy. Examples of Bayle's critical mode of investigation may be seen in his articles on the Greek sceptical philosophers, particularly those on Pyrrhonism, Zeno, Carneades, and Chryppus.

See Des Maizeaux, *Vie de Bayle*; Feuerbach, *Pierre Bayle*, 1836; Daniron, *Philosophie en France au xvii<sup>e</sup> Siècle*.

**BAYONET.** See **ARMS AND ARMOUR**, vol. ii. p. 558.

**BAYONNE**, probably the ancient *Lapurdum, Basotium civitas*, or *Basotium*, a first-class fortified city of France, and the capital of an arrondissement, in the department of the Lower Pyrenees. It is well built, and agreeably situated at the confluence of the Nive and Adour, about three miles from the sea. A bar at the mouth of the river, with 13 or 15 feet of water at spring tides and 9 to 11 feet at neaps, formerly prevented large vessels from entering except at high water; but works have been in progress by which the obstruction will be greatly lessened, if not altogether removed. The citadel is one of the finest works of Vauban, and the cathedral is a large and elegant Gothic structure of the 12th century. Bayonne is the seat of a bishopric, and has courts of primary jurisdiction and commerce, an exchange, a mint, a theatre, naval and commercial docks, and schools of commerce and navigation, as well as distilleries, sugar-refineries, and glass-works. It is likewise the centre of the 13th military division, and possesses one of the finest arsenals in France, and a military hospital for 2000 patients. Its export trade is considerable, particularly in grain, wine, fish, chocolate, liqueurs, cream of tartar, hams, rosin, turpentine, and timber. The Nive and Adour divide the town into three nearly equal parts, communicating with each other by bridges. Great Bayonne, which lies on the left bank of the Nive, contains the old castle; Little Bayonne, where the new castle stands, is situated between the Nive and the Adour; and Saint Esprit, formerly a suburb, occupies the right bank of the Adour. The last is inhabited almost exclusively by Jews. Bayonne, though often besieged, has never been taken, and is one of the few places that refused to participate in the massacre of St Bartholomew. The last siege was by the English in 1814, and was interrupted by the news of Napoleon's surrender. The bayonet derives its name from this place, where it is said to have been invented. Population in 1872, 26,335.

See Balasque and Dulaurens, *Etudes Historiques sur la ville de Bayonne*, 3 vols., which treats of the history down to 1451.

**BAZA** (the mediæval *Bastiana*), a city of Spain in the province of Granada, situated in a fruitful valley in the Sierra Nevada, not far from the river of its own name. In the time of the Moors it was one of the three most important cities in the kingdom of Granada, carrying on an extensive trade, and numbering no fewer than 50,000 inhabitants. It was captured by the Spaniards in 1489 after a seven months' siege. The city still contains various remains of Moorish architecture, as well as its ancient church, which had been converted into a mosque; and in the neighbouring plain have been discovered from time to time numerous relics of antiquity, both Roman and mediæval. The principal trade of the place is at present in hemp; its population numbers 7270. It is the birth-place of Ribera, the historian of Granada. In 1810 Soult defeated a large Spanish army in the immediate vicinity.

**BAZARD, ARMAND**, a French socialist, the founder of a secret political society in France, corresponding to the Carbonari of Italy, and a warm adherent of St Simon, was born at Paris in 1791. He took part in the defence of Paris in 1815, and afterwards occupied a subordinate situation in the prefecture of the Seine. About the year 1820 he united some patriotic friends into a society, which was called *Amis de la Vérité*. From this was developed a complete system of Carbonarism, the peculiar principles of which were introduced from Italy by two of Bazard's friends. Bazard himself was at the head of the central body, and, while taking a general lead, contributed extensively to the Carbonarist journal, *L'Aristarque*. An unsuccessful outbreak at Belfort ruined the society, and the leaders were compelled to conceal themselves. Bazard,

after remaining for some time in obscurity in Paris, came to the conclusion that the ends of those who wished well to the people would be most easily attained, not through political agitation, but by effecting a radical change in their social condition. This train of thinking naturally drew him towards the socialist philosophers of the school of St Simon, whom he joined. He contributed to their journal, *Le Producteur*; and in 1828 began to give public lectures on the principles of the school, which were well attended. His most important work, however, was the first volume of the *Exposition de la Doctrine de St Simon* (2 vols., 1828-30), by far the best account of that peculiar phase of socialism. The second volume was chiefly by Enfantin, who along with Bazard stood at the head of the society, but who was superior in metaphysical power, and was prone to push his deductions to extremities. The two leaders differed in opinion with regard to the emancipation of women, which Bazard disapproved. An open quarrel took place in 1831, and Bazard found himself almost deserted by the members of the society. He attacked Enfantin violently, and in a warm discussion between them he was struck down by apoplexy. After lingering for a few months he died on the 29th July 1832.

**BAZIGARS**, a tribe of Indians, inhabiting different parts of the peninsula of Hindustán. They are recognised by several appellations, as *Bazigars*, *Panchpiri*, *Kunjra*, or *Nats*; they follow a mode of life distinguishing them from the Hindus, among whom they dwell; they abstain from intermixing their families with the Hindus, and from any intercourse by which they can be united. They are dispersed throughout the whole of India, partly in wandering tribes, partly adhering to fixed residences, but the greater proportion lead a nomadic life.

The *Bazigars* are divided into seven castes; but besides those who are united into sects or castes, there are individuals who wander about endeavouring to pick up a precarious livelihood. Although the *Bazigars* are distinguished by their manners and customs from the natives of Hindustán, their features do not certainly discriminate them as a separate race. Some of their women are reputed very beautiful, and are thence sought after in those temporary alliances common in the East. The *Bazigars* more especially distinguished by that name are the most civilized of the whole; they are Mahometans in food, apparel, and religion. The *Panchpiri* profess no system of faith, in preference adopting indifferently that of any village whither their wanderings may guide them. Some traverse the country as Mahometan fakirs, and live on the chance bounty of devotees; and a particular association among them, of bad repute or abject superstition, has been accused of sacrificing human victims. The chief occupation of the *Bazigars* seems to consist in feats of address and agility to amuse the public, in which both males and females are equally skilful. The former are extremely athletic, and the women are taught dancing, which, instead of the graceful motions seen in the north, consists principally of a display of lascivious gestures. Most of the men are adroit jugglers, tumblers, and actors. Both males and females pursue a systematic course of debauchery, so that few live beyond forty, and many do not attain their thirtieth year. From the pursuits of the females being productive to their parents, their marriages are deferred to a later period than is usual in India. The females who do not attend the juggling exhibitions of the men, or their feats of activity, practise physic and cupping, and perform a kind of tattooing on the skin of the Hindus of their own sex, called *godna*. The men, besides their usual occupations, collect medical herbs, which are prepared by their wives as curatives, especially of the complaints of their own sex. In this manner, or by the sale of trinkets, they find employment in the towns,

though these occupations afford them but a precarious subsistence. Some tribes also go about exhibiting wild beasts, or offering for sale mats fabricated by themselves. Before the establishment of the British Government in Bengal, the Bázgars were subject to the arbitrary exactions of a tax-gatherer, whom they greatly dreaded, and the apprehension of the renewal of that officer's powers has proved a considerable impediment to investigating their manners and customs.

The Bázgars are supposed to present many features analogous to the gipsies scattered over Europe and Asia, where they subsist as a race distinct from all the other inhabitants of the countries frequented by them. The Bázgars, as well as the gipsies, have a chief or king; each race has a peculiar language, different from that of the people among whom they reside; and the analogy of the languages is so decided, that it is difficult to deny that they have had a common origin. Another resemblance, which has probably been lost in the lapse of time, is supposed to consist in the three-stringed viol introduced into Europe by the jugglers of the 13th century, which is exactly similar to the instrument now used in Hindustán. Disjoined, these analogies may not carry conviction of the identity of the European gipsies with the Indian Bázgars; but, on combining the whole, it does not seem unlikely, that if Asia was their original country, or if they have found their way from Egypt to India, they may also have emigrated farther at a period of remote antiquity, and reached the boundaries of Europe.

BAZZI, GIOVANNI. See SODDOMA.

BDELLIUM, a fragrant gum-resin of a dark-reddish colour, bitter and pungent to the taste. It is closely allied to myrrh, and like it is produced from one or more species of *Balsamodendron*,—the Googul resin, or Indian bdellium, yielded by *B. mukul*, being considered by Dr Birdwood to be the bdellium of Scripture, and the  $\beta\delta\lambda\lambda\iota\upsilon\omicron\nu$  of Dioscorides. Bdellium is little imported into Europe, but it is extensively used in Indian pharmacy, both human and veterinary; and it is, like myrrh, employed for incense in temples. A variety of the gum-resin known as African bdellium is produced on the East African coast, but nothing is certainly known regarding its botanical source.

BEACHY HEAD, a promontory on the coast of Sussex, between Hastings and Brighton, near which the French defeated the English and Dutch fleet in 1690. It consists of a perpendicular chalk cliff 530 feet high. A lighthouse, with a revolving light 285 feet above high-water mark, was erected in 1828 on the second cliff to the westward, in long.  $0^{\circ} 1' E.$ , lat.  $50^{\circ} 44' N.$

BEACONSFIELD, a market-town in the county of Buckingham, 23 miles from London, on the road to Oxford. It consists of four streets crossing each other at right angles, and before the opening of the railways was rather a busy place. At one time, indeed, it was the seat of a considerable manufacture of ribbons. The poet Waller and Edmund Burke lived in the neighbourhood, and both are buried in the town. Beaconsfield gave the title of viscountess to the late wife of the Right Hon. B. Disraeli. Population of parish in 1871, 1524.

BEAD, a small globule or ball used in necklaces, and made of different materials, as pearl, steel, garnet, coral, diamond, amber, glass, rock-crystal, and seeds. The Roman Catholics make great use of beads in rehearsing their *Ave-Marias* and *Pater-nosters*, and a similar custom obtains among the religious orders of the East. A string of such beads is called a rosary. Glass beads were used by the Spaniards to barter with the natives of South America for gold when they first established themselves on that continent, and to this day they are a favourite article of traffic with all savage nations. Beads of glass are sent in enormous quantities to Zanzibar, and to all other ports

from which a trade with the interior of Africa is carried on, as they form almost the only convenient medium of exchange with the native tribes. The qualities and varieties recognized in the Zanzibar market are said to number more than 400, and the trade there is almost entirely in the hands of the Banyana. Large quantities are also sent to India, the Eastern Archipelago, and the Polynesian Islands; and in the more primitive parts of Europe beads are in considerable demand. Under the name of bugles a very great quantity of small, mostly cylindrical, beads are used in lace-making, and for the ornamentation of ladies' dresses, the demand in this form fluctuating greatly according to the demands of fashion. Venice is the principal centre of the manufacture of glass beads of all kinds. The exports therefrom during the ten years ending with 1871 amounted to 313,201 quintals, of the value of 61,240,296 Italian lire. In the manufacture of ordinary beads, as conducted at Venice, rods or caues of glass of the colour and quality desired first are drawn out, either pierced or unpierced. The rods may either be of transparent glass, or of opaque coloured enamel glass (*smalta*), or may have complex patterns produced by the twisting of threads of coloured glass through a transparent body, characteristic of Venetian glass. From these rods rounded beads are pinched off, and the more costly kinds, made in imitation of precious stones, &c. are cut and faceted. Imitation pearls, the making of which forms an important part of the bead industry, are blown by the blow-pipe from a milky-white glass. The pearly lustre is communicated by the infiltration of a substance obtained from the scales of the bleak *Leuciscus alburnus*. The more costly imitation pearls receive several coats of the pearly substance, and have weight and solidity added by filling up the interior of the pearl with wax. Gold, silver, and various coloured lustres are frequently substituted for the pearly substance in the manufacture of blown beads.

BEAN, the seed of certain leguminous plants cultivated for food all over the world, and furnished chiefly by the genera *Faba*, *Phaseolus*, *Dolichos*, *Cajanus*, and *Soja*. The common bean, in all its varieties, as cultivated in Britain and on the continents of Europe and America, is the produce of the *Faba vulgaris*. The French bean, kidney bean, or haricot, is the seed of the *Phaseolus vulgaris*; but in India several other species of this genus of plants are raised, and form no small portion of the diet of the inhabitants. From the genus *Dolichos*, again, the natives of India and South America procure beans or pulse, of no small importance as articles of diet, such as the *D. ensiformis*, or sword bean of India, the Lima beans, &c. Besides these there are numerous other pulses cultivated for the food both of man and domestic animals, to which the name beans is frequently given. The common bean is even more nutritious than wheat; and it contains a very high proportion of nitrogenous matter under the form of legumin, which amounts on an average to 24 per cent. It is, however, a rather coarse food, and difficult of digestion, and is chiefly used to feed horses, for which it is admirably adapted. In England French beans are chiefly, almost exclusively, used in the green state; the whole pod being eaten as a table vegetable, or prepared as a pickle. It is wholesome and nutritious; and in Holland and Germany the pods are preserved in salt by almost every family for winter and spring use. The green pods are cut across obliquely, most generally by a machine invented for the purpose, and salted in barrels. When wanted for use they are steeped in fresh water to remove the salt, and broiled or stewed; they form an agreeable addition to the diet at a time when no other vegetable may be had. Under the name of carob beans or locusts, the legume of *Ceratonia siliqua* is cultivated on the shores of the Mediterranean



and used as food for cattle. The shells of the carob bean contain a large proportion of sugar, and are often consumed as a dainty by children. These beans were formerly supposed to be the locusts eaten by John the Baptist, and hence have been called St John's bread. The Tonka, or Tonquin bean, is the produce of *Dipteris odorata*, a leguminous seed with a fine odour, used in perfumery and largely for scenting snuff. The Calabar ordeal bean is a highly poisonous leguminous seed. There are also several non-leguminous seeds to which the popular name bean is attached. Among these may be mentioned the sacred Egyptian or Pythagorean bean (*Nelumbium speciosum*), and the Ignatius bean (probably *Strychnos multiflora*), a source of strychnine. For the cultivation, &c., of the common bean, see *AGRICULTURE*, vol. i. p. 360. The ancient Greeks and Romans made use of beans in gathering the votes of the people, and for the election of magistrates. A white bean signified absolution, and a black one condemnation. Beans had a mysterious use in the *lemuralia* and *parentalia*, where the master of the family, after washing his hands three times, threw black beans over his head nine times, continuing to repeat the words, "I redeem myself and my family by these beans."

**BEAR**, the common name of the *Ursidae*, a typical family of Plantigrade Mammals, distinguished by their massive bodies, short limbs, and almost rudimentary tails. With the single exception of the Honey Bear, all the species have forty-two teeth, of which the incisors and canines closely resemble those of the purely carnivorous mammals; while the molars, and especially that known as the "carnassial," have their surfaces tuberculated so as to adapt them for grinding vegetable substances. As might have been supposed from their dentition, the bears are truly omnivorous; but most of the family seem to prefer vegetable food, including honey, when a sufficient supply of this can be had. The Grizzly Bear, however, is chiefly carnivorous; while the Polar Bear, in a state of nature, is believed to be almost wholly so. The strength and ferocity of different species and of different individuals of the same species seem to depend largely on the nature of their diet,—those restricted to purely vegetable food showing an approach to that mildness of disposition characteristic of herbivorous animals.

Bears are five-toed, and are provided with formidable claws, but these are not retractile as in the cats, and are thus better fitted for digging and climbing than for tearing. Most of the bears climb trees, which they do in a slow, lumbering fashion, and, in descending, always come hind-quarters first. The Grizzly Bear is said to lose this power of climbing in the adult state. In northern countries the bear retires during the winter season into caves and the hollows of trees, or allows the falling snow to cover it, where it remains dormant till the advent of spring, about which time the female usually produces her young. These are born naked and blind, and it is commonly five weeks before they see, or become covered with hair. Before hibernating they grow very fat, and it is by the gradual consumption of this fat—known in commerce as bear's grease—that such vital action as is necessary to the continuance of life is sustained.

The bear family is widely distributed, being found in every quarter of the globe except Australia, and in all climates, from the highest northern latitudes yet reached by man to the warm regions of India and Malaya. In the north-west corner of Africa the single representative of the family found on that continent occurs. Of the remaining species described in Gray's recent monograph of this family, three are European, six American, and eight Asiatic; while one species—the Polar Bear—is common to the Arctic regions of both hemispheres. In addition to these, the

best known species are peculiarly rich in varieties. Bears have been recently divided into three groups,—sea bears, land bears, and honey bears.

(1.) Sea bears, of which the Polar or White Bear (*Thalassarctos maritimus*) is the only species known, are distinguished from the other groups by having the soles of the feet covered with close-set hairs,—a beautiful instance of special adaptation to the wants of the creature, the bear being thereby enabled to walk more securely on the slippery ice. In the whiteness of its fur also, it shows such an assimilation in colour to that of surrounding nature as must be of considerable service in concealing it from its prey. The food of the White Bear consists chiefly of seals and fish, in pursuit of which it shows great power of swimming and diving, and a considerable degree of sagacity. It also feeds on the carcasses of whales, and on birds and their eggs, and is said to eat berries when these can be had. That it can sustain life on a purely vegetable diet is proved by instances on record of its being fed for years on bread only, in confinement. These bears are strong swimmers, Captain Sabine having found one "swimming powerfully forty miles from the nearest shore, and with no ice in sight to afford it rest." They are often carried on floating ice to great distances, and to more southern latitudes than their own, no fewer than twelve Polar bears having been known to reach Iceland in this way during one winter. The female always hibernates, but the male may be seen abroad at all seasons. In bulk the White Bear exceeds all other members of the family, measuring nearly 9 feet in length, and often weighing 1600 lb.

(2.) Land bears have the soles of the feet destitute of hair, and their fur more or less shaggy. Of these the Brown Bear (*Ursus arctos*,—*Ἄρκτος* of Aristotle) is found in one or other of its varieties all over the temperate and north temperate regions of the eastern hemisphere, from Spain to Japan. Its fur is usually of a brownish colour, but there are black, blackish-grey, and yellowish varieties. It is a solitary animal, frequenting the wooded parts of the regions it inhabits, and living on a mixed diet of fruits, vegetables, honey, and the smaller animals. In winter it hibernates, concealing itself in some hollow or cavern. It does not seek to attack man; but when baited, or in defence of its young, it shows great courage and strength, rising on its hind legs and endeavouring to grasp its antagonist in an embrace. Bear-baiting, till within comparatively recent times, was a favourite sport throughout Europe, but along with cock-fighting and badger-baiting, has gradually disappeared before a more humane civilization. It was a favourite pastime among the Romans, who imported their bears from Britain, a proof that the animal was then comparatively abundant in that country; indeed, from reference made to it in early Scottish history, the bear does not appear to have been extirpated in Britain before the end of the 11th century. It is now found in greatest abundance in Norway, Russia, and Siberia, where the bear hunt is the favourite sport, and where, when dead, it remains are highly valued. Among the Kamchatkans "the skin of the bear," says a traveller, "forms their beds and their coverlets, bonnets for their heads, gloves for their hands, and collars for their dogs. The flesh and fat are their dainties. Of the intestines they make masks or covers for their faces, to protect them from the glare of the sun in the spring, and use them as a substitute for glass, by extending them over their windows. Even the shoulder-blades are said to be put in requisition for cutting grass." In confinement the Brown Bear is readily tamed; and advantage has been taken of the facility with which it can sustain itself on the hind feet to teach it to dance to the sound of music. It measures 4 feet in length, and is about 2½ feet high.

The American Black Bear (*Ursus americanus*) occurs

throughout the wooded parts of the North American continent, whence it is being gradually driven to make room for man. It is similar in size to the Brown Bear, but its fur is of a soft even texture, and of a shining black colour, to which it owes its commercial value. At the beginning of the present century Black Bears were killed in enormous numbers for their furs, which at that time were highly valued. In 1803 the skins imported into England numbered 25,000, but the imports have since decreased to one-half of that number. They are chiefly used for military accoutrements. This is a timid animal, feeding almost solely on fruits, and lying dormant during winter, at which period it is most frequently killed. It is an object of superstitious reverence to the Indians, who never kill it without apologizing and deploring the necessity which impels them to do so.

The Grizzly Bear (*Ursus ferox*) approaches the Polar Bear in size, while it exceeds that, and all other American mammals, in ferocity of disposition and in muscular strength. It is said to attack the bison, and has been known to carry off a carcase weighing 1000 lb for a considerable distance to its den, there to devour it at leisure. It also eats fruit and other vegetables. Its fur is usually of a yellowish brown colour, coarse and grizzled, and of little value commercially, while its flesh, unlike that of other bears, is uneatable even by the Indians. It is found in greatest abundance on the eastern slopes of the Rocky Mountains. The Syrian Bear (*Ursus syriacus*) occurs on Mount Lebanon and throughout Syria, and is probably the species mentioned in Scripture as having destroyed the "forty-and-two children" who mocked Elisha. It is of a dirty yellowish colour, and feeds mainly on vegetables. The Bruang or Malayan Bear (*Helarctos malayanus*) is of a jet black colour, with a white semilunar mark on the chest, and attains a length of 4½ feet. Its food consists almost solely of vegetables and honey, but the latter is its favourite food,—the extreme length and pliability of the tongue enabling it to scoop out the honey-combs from the hollows of trees. It is found in the Malay Peninsula and Islands, and is readily tamed.

(3.) Honey bears are distinguished from the other groups by the absence of two upper incisors, and the very extensible character of the lips. Of these there is but one species, the Sloth or Honey Bear (*Melurus labiatus*). This animal, from its striking outward resemblance to a sloth, was, when first brought to this country, described as a species of *Bradypus*. It is about the size of the Brown Bear, is covered with long, black hair, and is of extremely uncouth aspect. It inhabits the mountainous regions of India, is readily tamed, and is the bear usually exhibited by the Hindoo jugglers. It feeds on fruits, honey, and white ants.

Fossil remains of extinct bears first occur in strata of the Pliocene age. Those of the Great Cave Bear (*Ursus spelæus*), found abundantly in certain caverns of Central Europe and Asia, show that it must have exceeded in size the Polar Bear of the present day. Its remains are also found in similar situations in Britain associated with those of an allied species (*Ursus priscus*).

**BEAR LAKE, GREAT**, an extensive sheet of fresh water in the north-west of Canada, between 65° and 67° N. lat., and 117° and 123° W. long. It is of a very irregular shape, has an estimated area of 14,000 square miles, and is upwards of 200 feet above the sea. The Bear Lake River carries its waters into the Mackenzie River.

**BEARD.** The tradition that Adam was created with a beard (which may be described as bushy rather than flowing), is recorded on ancient monuments, and especially on an antique sarcophagus, which is one of the ornaments of the Vatican. The Jews, with the Orientals generally, seem to have accepted the tradition for a law. The beard

was a cherished and a sacred thing. Moses thought it safe out of the bondage of a universally shaven Egypt, and the beard was the outward and visible sign of a true man. To rudely touch his beard was to cruelly assail his dignity. Children and other kinsfolk might gently touch it as a sign of love; a fugitive might reverentially raise his hand to it when praying for succour; and he who put his hand on his own beard and swore by it bound himself by the most solemn of oaths, to violate which would render him infamous among his fellow-men. To touch the beard in the allegiance of love established peace and trustfulness between the two parties. When Joab went in to Amasa he took the beard of the latter to kiss him, saying the while, "Art thou in health, my brother!" Therefore it was that Amasa took no heed of the sword in Joab's hand, which Joab at once thrust beneath the other's fifth rib. The Scriptures abound with examples of how the beard and its treatment interpreted the feelings, the joy, the sorrow, the pride, or the despondency of the wearer.

Although the Jews carried their beards with them from their bondage in Egypt, the Egyptians were not at all insensible of the significance of that appendage. They did not despise the type of manhood. Accordingly, on days of high festival they wore false beards, as assertions of their dignity in the scheme of creation, and they represented their male deities with beards "tip-tilted" at the ends. The general reader having laudable curiosity on this matter may be safely referred to the pages of Herodotus,—a writer who has much to say pertinently to the subject, and who, after being maligned as the second father of lies, is now praised for his modesty, and relied on for his trustworthiness.

The modern Mahometans, especially those who have most come in contact with Europeans, have a good deal fallen away from old conservative ideas respecting the beard. Once, this glorious excrescence, as it was held to be, was made, by the followers of Islam, a help to salvation. The hairs which came from it in combing were preserved, broken in two, and then buried. The breaking was a sort of stipulation with some angel who was supposed to be on the watch, and who would look to the safe passage of the consigners of the treasure into the paradise of never-failing sherbet and ever-blooming hours. The first sultan who broke through the orthodox oppression of beardedness was Selim I. (1512–20). This act was a violent shock to the whole body of the faithful, and especially of the Mufti. The very highest priest alone could dare to remonstrate with so absolute a monarch. Selim put aside the remonstrance with a joke. "I have cut off my beard," he said, "in order that my vizier may have nothing to lead me by!" But a crafty minister can find on the face of the most beardless and cruel of despots wherewithal to lead him in the way the minister would have him go. Still, the fact that the Prophet never let razor reap a harvest on his chin, for "possession of the hairy produce of which all Islam would have fought with affectionate fury, long made, and still makes, the beard a part of religion. The sultan and the shah, chiefs of the two parties in their church, have pretty fair apologies for beards; but this is far below the bearded glories of the days before the Prophet, when the kings of Persia tied up their bearded plaits with gold thread, and the princes of Nineveh went abroad with beards curled and oiled, like the Assyrian bulls themselves. It has been said that in Asia wars have been proclaimed on alleged grievances connected with shaving. Tartars and Persians, and Chinese and Tartars, are reported to have resorted to sanguinary arbitration on the question of clipping or shaving. Probably they who declared the war were as clever in finding a pretext as the more civilized aggressors of much later days.

If we turn to Europe and begin with classical times, having—

the wealth of Ormus and of Ind.  
Or where the gorgeous East, with richest hand,  
Showers on her kings barbaric pearl and gold,—

we may remember that the Greeks and Romans once styled as barbarians, or bearded, unshaven savages, all nations who were out of the pale of their own customs and religion. Nevertheless, the young Roman, anxious for beard and moustache, used to apply the household oil to his chin and cheeks, in order to bring thereon that incipient fringe which would entitle him to be called "barbatulus." The full-furnished man was "barbatua." It was not till the beard ceased to be universally worn, and Sicilian barbers set up in Rome (about 300 a.c.), that the Romans began to apply the word, translated "barbarous," to the rude men and manners of the early ages, and of the beard universal. But, after all, we may still see, in old counterfeit presentments, that the fashionable, clipped beard of young Roman "swells" in the last days of the Republic, and of some of the emperors from the time of Hadrian, is not nearly so majestic as the flowing hair depending from the chin of Numa Pompilius. Nerva offered some of the hair of his beard to Jupiter Capitolinus, who could have furnished a dozen emperors from his own. Homer, Virgil, Pliny, Plutarch, Strabo, Diodorus, Juvenal, Persius, are among the writers who furnish material for a volume on beards. One Roman emperor, Julian, wrote a work on the subject, which is commonly supposed to be as fierce a denunciation against beards, as King James's *Blast* was against tobacco; but Julian in his *Misopogon*, or *Enemy of the Beard*, descants satirically "with pleasure and even with pride," says Gibbon, "on the length of his nails and the inky blackness of his hands, protests that although the greatest part of his body was covered with hair, the use of the razor was confined to his head alone, and celebrated with visible complacency the shaggy and populous beard which he fondly cherished, after the example of the philosophers of Greece." Persius undoubtedly associated wisdom with the beard. He exhausted the whole vocabulary of praise when he designated Socrates by the term *Magister Barbatus*. In this, however, there is less wit than in the rejoinder of the young ambassador to a king, who had expressed his wrath at having a beardless youth sent to him as an envoy. "If," said the latter, "my master had thought you would have laid so much account on a beard, he would have sent you a goat."

The most notable circumstance in the history of the beard among the Greeks is that of its abolition,—in the Macedonian army, at least, for strategic reasons. Alexander the Great abolished the beards of his soldiers, for the sufficient reason that they gave handles to their enemies whereby to lay hold of them. The Macedonian warriors probably obeyed with reluctance; but obedience was as much a matter of course as it was with the Ephori who, by Lacedæmonian law, had to undergo what seemed the ridiculous ceremony of being shaved, merely to show their ready obedience to legal enactment. As they were mortal men, it may be supposed that acquisition of office was happy compensation for the loss of a beard.

*Goth* is equivalent for the older term of *Barbarian*. One is about as unjust in its application as the other. Gothic rudeness is often illustrated by the case of the "ugly rush" made by the northern warriors into the Capitol, where the conscript fathers sat in silence and fearlessness, waiting events. One of these unlettered soldiers lifted his hand to the beard of an old legislator, who, taking it for insult, smote the Goth to the ground. Let us do the Goth the justice of believing that, awed by

the stern mute majesty of the senators, he raised his hand reverentially to the beard. At all events, the taking it with such prompt and painful action was dearly paid for in the swift retaliation which followed.

If the phrase be not too light for use, we would say that as beards existed before barbers, the Europeans, like all other people, were originally a bearded people. The beard is perhaps more general now in Germany than elsewhere in Europe; and Germany affords an example of the longest beard known, out of fairy story, in the person of the painter Johan Mayo, whose beard was so long that when he stood upright it still trailed on the ground; accordingly, he often doubled it up in his girdle. Germany knows him as John the Bearded, just as it does one of its emperors as Frederick Barbarossa; but many nations, ancient and modern, can boast of men and monarchs who have been nicknamed from their beards.

When Peter the Great levied a tax on Russian beards, he was only following a precedent which once existed in England. Noble chins were assessed at a rouble; your commoner chin at a copeck. It caused commotion, and there was much compulsory shaving of those who did not pay. Beards are not now valued in Russia. He who wears one seems to acknowledge that he has no very high place in the social scale. On the other hand, beards were highly treasured in Spain till the time of Philip V., who was unable to cultivate one. As was to be expected, this infirmity set the fashion of affecting the infirmity; but beardless dons were wont to exclaim with a sigh, "Since we have lost our beards, we have lost our souls!" Thus, they unconsciously adopted something akin to the superstition of the Roskolniki, a sect of schismatics who obstinately maintained that the divine image resided in the beard. Portugal was not behind Spain in appreciating the beard. When the Portuguese admiral, Juan de Castro, borrowed a thousand pistoles from the city of Goa, he lent in pledge one of his whiskers, saying, "All the gold in the world cannot equal this natural ornament of my valour." In these modern days one would not think much of the security of such a material guarantee, nor of the modesty of the admiral who might have the face to offer it.

As Spaniards denuded their chins because their king could not grow a beard, so the French grew beards, long after they had gone out of fashion, because their king found it necessary to do so. Francis the First, having wounded his chin, concealed the ugly scar by covering it with a beard; and all loyal chins forthwith affected to have scars to conceal. But when fashion and loyalty were united the beard was carefully tended. It was not as in the time of the idle, helpless, and long haired kings, who were less potential than their chief officers, when the wild, dirty, and neglected beard was a type of that majesty, made up of shreds and patches, which used to be paraded before the people on a springless cart. Three hairs from a French king's beard under the waxen seal stamped on royal letter or charter, were supposed to add greater security for the fulfilment of all promises made in the document itself. In course of time fashion complimented majesty; a certain sort of moustache was called a "royale," and the little tuft beneath the lower lip was known by the term "imperiale." As a rule, the French chin assumed the appearance of that of the king for the time being. The royal portrait reflects a general fashion from which only the disloyal or the indifferent departed. On the subject of shaving, Talleyrand once drew a fine distinction. Rogers asked him if Napoleon shaved himself. "Yes," replied the statesman; "one born to be a king has some one to shave him; but they who acquire kingdoms shave themselves." Tradition has exaggerated accounts of bearded prisoners in the Bastille, but there was an official there whose duty consisted in

keeping the captives without beards. Some years before the Revolution the celebrated lawyer and political writer Linguet was incarcerated there. On the morning after his being locked up, an individual entered his room who announced himself as the barber of the Bastille. "Very well," said the sharp-witted Linguet, "as you are the barber of the Bastille—*rasez-la*."

Among the men of whom it was said of old that they would be known by their love for one another, the beard has been a cause of much fierce uncharitableness. The Greek Church, advocating the beard, and the Roman Church, denouncing it, were not more forgetful of ever-blessed charity than the Belgian Reformers, the close-shaven of whom wished the bearded members to be expelled as non-Christians. The tradition concerning the Master whom both proposed to follow was logically pleaded by the wearers of beards. As a general rule, in the earlier time, the man who wore his hair short and his beard long, was accounted as at least bearing the guise of respectability,—looking like a priestly personage. There is a series of medals of the popes at Naples, from Clement VII. (1523-34) to Alexander VIII. (1689-91). All these are bearded. Clement's beard is long and dark; Alexander wears beard and moustaches. Perhaps Clement Giulio de' Medici set the fashion. Certain it is that a few years before, his kinsman, Giovanni de' Medici, Leo X. (1513-22), was always close-shaven, and beards were not to be seen on the chin of Leo's clerics and courtiers.

In the 13th century beards are said to have first come into fashion in England. If we may judge from the 15th century brasses in England, few men of distinction enough to be so commemorated wore beards. Hotspur's fop had his "chin new reaped." In the reign of Henry VIII. the fashion had so revived among lawyers that the authorities of Lincoln's Inn prohibited wearers of beards from sitting at the great table, unless they paid double commons; but in all probability this was before that sovereign ordered (1535) his courtiers to "poll their hair," and he let that crisp beard grow which is familiar to us all. Thence came a fiscal arrangement; beards were taxed, and the levy was graduated according to the condition of the wearer. In the Burghmote Book of Canterbury (quoted in *Notes and Queries*) there is the following entry:—"2nd Ed. vi. The Sheriff of Canterbury and another paid their dues for wearing beards, 3s. 4d. and 1s. 8d." In the next reign, and in the year 1555, Queen Mary sent four agents to Moscow; all were bearded, but one of them, a certain George Killingworth, was especially distinguished by a beard 5 feet 2 inches long, at sight of which a smile crossed the grim features of Ivan the Terrible himself. George's beard was thick, broad, and yellow; and, after dinner, Ivan played with it, as with a favourite toy. Most of the Protestant martyrs were burnt in their beards. Sir Thomas More, on the other hand, put his out of the way, as he laid his head on the block, with the innocent joke so well known. Elizabeth introduced a new impost with regard to beards. Every beard of above a fortnight's growth was subject to a yearly tax of 3s. 4d. The rate was as heavy as the law authorizing it was absurd. It was made in the first year of her reign, but it proved abortive. Fashion stamped it out, and men laughed in their beards at the idea of paying for them. The law was not enforced, and the Legislature left the heads of the people alone till much later times, when necessity and the costs of war put that tax on hair-powder which even now contributes a few thousands a year to the British Exchequer. The Vandyke beard, pointed (as Charles the First and the illustrious artist, with most cavaliers, wore it), was the most universally worn for a time. Beaumont and Fletcher, in the *Queen of Corinth*, make allusion, doubtless, to a fashion of wearing

moustache and beard, common to the reign of the first James as well as that of Charles.

"His beard  
Which now he puts i' the posture of a T,—  
The Roman T. Your T beard is the fashion,  
And twofold doth express th' enamoured courtier  
As full as your fork-carrying traveller."

John Taylor, the water-poet, notices the T beard, and mentions at least a score of the various ways of wearing beards in his time, not forgetting the contemporary proverb, "Beard natural, more hair than wit." Hudibras, in text and notes, affords numerous illustrations of this subject. The general idea that beards did not come back with the monarchy does not seem to be correct, if the old song (date 1660) is to be trusted—

"Now of beards there be such a company,  
Of fashions such a throng,  
That 'tis very hard to treat of the beard,  
Tho' it be never so long."

Soon after this time, however, the beard in England was everywhere kept down by the razor. At the close of last century the second Lord Rokeby (Mat. Robineau) endeavoured to restore the fashion. "His beard," says a contemporary, "forms one of the most conspicuous traits of his person." But too short a period had elapsed since Lord George Gordon, the hero of "the Riots," had turned Jew and let his beard grow, to allow of any favour being awarded to an appendage which seemed a type of infamy. To the literature of the beard a remarkable addition was made in the present century by James Ward, R.A., the celebrated animal painter. Mr Ward published a *Defence of the Beard*, on Scriptural grounds; he gave eighteen reasons why man was bound to grow a beard, unless he was indifferent as to offending the Creator and good taste; for the artist asserted himself as much as the religious zealot, and the writer asked, "What would a Jupiter be without a beard! Who would countenance the idea of a shaven Christ!" Mr Ward had what the French call "the courage of his opinions," and wore a beard of the most Jupiter-like majesty. Mr Muntz, M.P. for Birmingham, followed the example, but it was not adopted by many others. A new champion, however, appeared in 1860, but on peculiar ground. "Theologos" expressed his views in the title-page of his work, namely,—*Shaving: a breach of the Sabbath, and a hindrance to the spread of the Gospel*. A carrying out of the views of the writer would lead to the full practice which prevailed among the Essenes, who never did on the Sabbath anything whatever that they were in the regular habit of doing on other days. "Theologos" points out that God gave the beard to man as a protection for his throat and chest; and, he adds, with the most amusing simplicity, "Were the beard in any other position its benefit and purpose might be doubted; but situated where it is, no physiologist will dare to deny its intention." Since this naive assertion was made, the beard, but not as a consequence, has grown into favour; and though not universal, it is at least general, and a familiar sight to us all.

There is a disagreeable branch of the subject, demanding only a passing word, namely, bearded women, hermaphroditic creatures, who have occasionally been found in all conditions of life, from princesses in "marble halls" to objects shown in exhibition-rooms or in vans at country fairs.

—"You should be woman,"

says Macbeth,

"And yet your beards forbid me to interpret  
That you are so."

Sir Hugh Evans expressed the suspicion which attached to a bearded woman, when he said of Falstaff, disguised as Mother Prat, "By yea and no, I think the woman is a witch

indeed; I like not when a 'oman has a great beard; I spy a great beard under her muffler." The detestation with which a bearded woman and a red-haired man were visited in France is almost savagely illustrated in the following old lines:—

"Henne roux et femme barbe,  
De trente pas loin le salue,  
Avequs trois pierres au poing,  
Pour Ven aider à ton besoing."

(J. DO.)

**BÉARN**, formerly a small frontier province in the south of France, now included within the department of Basses-Pyrénées, was bounded on the W. by Soule and Lower Navarre, on the N. by Chalosse, Tursan, and Astarac, E. by Bigorre, and S. by the Pyrenees. Its name can be traced back to the town of Benaharnum, which first appears in the Antonine Itinerary. The population is mainly of Basque origin, with possibly a certain mixture of Greek blood from the ancient colonies of that people. The Basque language, in spite of the diffusion of French, is still maintained in the district; and it is asserted that traces of old Hellenic names are not infrequent. Béarn begins first to take rank as a separate viscounty under Louis the Pious. From its first viscounts, who were descended from the dukes of Gascony, it passed about 1134, by failure of the male line, to the Catalonian family of Moncada; and after the people, who were hostile to all connection with Spain, had several times chosen their own leaders, it passed to the family of Foix, from whom it was transmitted through the houses of Grailly and D'Albret to the Bourbons, who, in the person of Henry, IV., made it an appanage of the crown of France. It was not till 1620, however, that it was formally incorporated; and even till 1790 it continued to be governed by its own constitution or system of *Fora*, which only exists in the form in which it was drawn up in 1288, though mention is made of it as early as 1080. The parliament of Béarn consisted of two sections, the first composed of the clergy and the nobles, and the second of mayors and councillors (or *jurats*) from forty-two towns or communities. It met every year, and was always presided over by the bishop of Lescar. A body of commissioners, called the *abrégés des états*, or epitome of parliament, was selected from the members—twelve from the nobles and twelve from the third estate—for the purpose of deciding any business that might demand attention during the time between the regular sessions. The administration of justice devolved in the last resort on a *cour sajour*, or greater court, which was changed by Henry d'Albret into a sovereign council under the presidency of the chancellor of Navarre and Béarn, and afterwards, by Louis XIII., into a *parlement* of the ordinary type. Histories of Béarn have been written by Belloy (1608), Marca (1640), D'Oihagaray (1609), Faget de Baure (1818), Mazure (1839).

**BEATON, DAVID**, archbishop of St Andrews and cardinal, was a younger son of John Beaton of Balfour in the county of Fife, and is said to have been born in the year 1494. He was educated at the universities of St Andrews and Glasgow, and afterwards studied at Paris. His first preferment was the parsonage of Campsie and the chancellorship of the church of Glasgow, to which he was presented in the year 1519 by his uncle James Beaton, then archbishop of Glasgow. When James Beaton was translated to St Andrews he resigned the rich abbacy of Arbroath in his nephew's favour, under reservation of one half of the revenues to himself during his lifetime. The great ability of Beaton and the patronage of his uncle ensured his rapid promotion to high offices in the church and kingdom. He was sent by King James V. on various missions to France, and in 1528 was appointed keeper of the privy seal. He took a leading part in the negotiations

connected with the king's marriage, first with Magdalen of France and afterwards with Mary of Lorraine. At the French court he was held in high estimation by King Francis I., and was presented to the bishopric of Mirepoix in Languedoc, to which he is said to have been consecrated on 5th December 1537. On the 20th of December 1538 he was appointed a cardinal priest by Pope Paul III., under the title of St Stephen in the Coelian Hill. He was the only Scotman who had been named to that high office by an undisputed right, Cardinal Wardlaw, bishop of Glasgow, having received his appointment from the Antipope Clement VII. On the death of Archbishop James Beaton in 1539, the cardinal was raised to the primatial see of Scotland. He showed his sense of the additional responsibility he had now undertaken by requesting the Pope to relieve him, to some extent, by the nomination of a suffragan or coadjutor in the diocese of St Andrews; and this was effected by the appointment to that office of William Gibson, dean of Restalrig, who received consecration as titular bishop of Libaria.

Beaton was one of King James's most trusted advisers, and is said to have taken a part in dissuading him from his proposed interview with Henry VIII. at York. On the death of James in December 1542 he attempted to assume office as one of the regents for the infant sovereign Mary, founding his pretensions on an alleged will of the late king; but his claims were disregarded, and the Earl of Arran, head of the great house of Hamilton, and next heir to the throne, was raised to the regency. The cardinal was imprisoned by order of the regent, but after some time was set at liberty. He was subsequently reconciled to Arran, and in September 1543 crowned the young queen at Stirling. Soon afterwards he was raised to the highest office under the regent, that of Chancellor of Scotland, and was appointed *legate a latere* by the Pope. The cardinal, in virtue of the latter dignity and of his primatial authority, claimed precedence over Archbishop Dunbar of Glasgow, even within the precincts of the cathedral of St Kentigern. This led to an unseemly brawl between the attendants of the two archbishops, as set forth in a formal complaint made by the cardinal to the Pope, and related at more length and with characteristic glee by Knox. The attention, however, of the cardinal was directed to matters of more importance than disputes with a brother metropolitan.

The two questions which agitated Scotland at this time were the struggle for ascendancy between the supporters of English and French influence, and that between the friends of the hierarchy and the teachers of the Reformed opinions,—questions which frequently became complicated in consequence of the assistance given by France to the bishops, and the encouragement which, for political reasons, the king of England secretly gave to the adherents of the Reformation. In this contest the cardinal supported the interests of France, resolutely opposing the selfish intrigues of King Henry and his party, which had for their object the extinction of the ancient independence of the Scottish kingdom and its subjection to the supremacy of England. Had he been content with this he would have won for himself the gratitude of his countrymen; but his evil deeds as an ecclesiastic made them overlook his patriotic exertions as a statesman. During the lifetime of his uncle he had taken his share in the persecuting policy of the hierarchy, and the same line of conduct was still more systematically adopted after his elevation to the primacy. Having won over the regent to his opinions he became more open and severe in his proceedings. The popular accounts of the persecution are no doubt exaggerated, and it sometimes ceased for considerable periods so far as capital punishments were concerned. When the sufferers were of humble rank

general attention was not much directed to them. It was otherwise when a more distinguished victim was selected in the person of George Wishart. This preacher, whose ecclesiastical opinions resembled those of Patrick Hamilton and Hamilton's teacher, Francis Lambert, returned to Scotland after an absence of several years about the end of 1544. His sermons produced a great effect, and he was protected by several of the barons who were leading men in the English faction. These barons, with the knowledge and approbation of King Henry, were engaged in a plot against the cardinal, in which his assassination was contemplated as the speediest mode of removing the chief obstacle to the influence of England. Of the reality of the plot and the intentions of the conspirators there can be no doubt: whether Wishart was aware of these has been a matter of controversy during the present century. There are strong suspicions against him but no sufficient evidence; and all the presumptions which may be drawn from his personal character are entirely in his favour. The cardinal, though ignorant of the details of the plot, perhaps suspecting Wishart's knowledge of it, and in any event desirous to seize one of the most eloquent supporters of the new opinions, endeavoured, with the aid of the regent, to apprehend him, but was baffled in his efforts for some time. He was at last successful in seizing the preacher, and bringing him a prisoner to his castle of St Andrews. On the 28th of February 1546 Wishart was brought to trial within the cathedral church, before the cardinal and other ecclesiastical judges, the regent declining to take any active part. He defended his opinions with temper and moderation; but as he admitted certain of them which were held by his judges to be heretical, he was condemned to death and burnt.

The persecution of Wishart, and the meekness with which he bore his sufferings, produced a deep effect on the mind of the Scottish people, and the cardinal became an object of general dislike. Those who hated him on other grounds were encouraged to proceed with the design they had formed against him. Naturally resolute and fearless, he seems to have undervalued the strength and character of his enemies, and even to have relied on the friendship of some of the conspirators. He crossed over to Angus, and took part in the magnificent ceremonies of the marriage of his illegitimate daughter with the heir of the Earl of Crawford. On his return to St Andrews he took up his residence in the castle. The conspirators, the chief of whom were Norman Leslie, Master of Rothes, and William Kirkcaldy of Grange, contrived to obtain admission at daybreak of the 29th of May 1546, and murdered the cardinal under circumstances of horrible mockery and atrocity. The assassination excited very different feelings among the partisans on either side. The zealous adherents of the Church of Rome, as a matter of course, viewed it as a cruel murder aggravated by sacrilege; the most violent of the Protestant party justified and even applauded it. Those who, without any strong feelings either way, disliked the cardinal on account of his arrogance and cruelty, spoke of the deed as a wicked one, but hardly professed to regret the victim. Ignorant of the treasonable designs of his enemies, viewing him as the champion of ecclesiastical supremacy, and attributing to him all the evils of the unsuccessful war with England, they looked upon his death as an advantage to the Scottish kingdom. The men of that age were too much accustomed to such violent deeds to entertain a great abhorrence of assassination, and such feelings and crimes were not confined to the adherents of the Reformation. A few years afterwards Martinuzzi, the cardinal archbishop of Gran, was murdered by the express command of a Roman Catholic prince, Ferdinand, king of the Romans, brother of the Emperor Charles V.

The character of Beaton has already been indicated. As a statesman he was able, resolute, and in his general policy patriotic. As an ecclesiastic he maintained the privileges of the hierarchy and the dominant system of belief conscientiously, but always with harshness and sometimes with cruelty. The immoralities of the cardinal, like his acts of persecution, were exaggerated by his opponents; but his private life was undoubtedly a scandal to religion and the church, and has only the poor excuse that it was not worse than that of most of his order at the time. The authorship of the writings ascribed to him in several biographical notices rests on no better authority than the apocryphal statements of Dempster. (G. A.)

BEATTIE, JAMES, a Scottish poet and writer on philosophy, was born at Laurencekirk on the 25th October 1735. His father, a small farmer and shopkeeper, died when he was very young; but an elder brother took charge of the boy, and observing his aptitude for learning sent him to Marischal College, Aberdeen, where he gained a bursary. In 1753 he was appointed schoolmaster of Fordoun, at the foot of the Grampian hills, amongst splendid scenery, which impressed itself deeply on Beattie's somewhat poetical mind. In 1758 he obtained a situation as undermaster in the grammar school, Aberdeen, and two years later he was made professor of moral philosophy at Marischal College. Here he became closely acquainted with Reid, Campbell, Gerard, and others, who formed a kind of literary or philosophical society, in which speculative questions, above all the views of Hume, were canvassed and criticized. In 1770 Beattie published his *Essay on the Nature and Immutability of Truth*, in which he attacked Helvetius and Hume, and advocated the doctrine afterwards familiarly known as that of Common Sense. The work had an astonishing success, and its author, when on a visit to London in 1773, was received with the greatest honour by the king himself. About the same time he received a pension of £200 a year. In 1773 and 1774 he published the first and second parts of *The Minstrel*, which were received with great favour, and gained for the author a fresh accession of popularity. His later writings are partly literary, such as the *Essays*, 1766; *Dissertations*, 1783, partly philosophical; *Evidences of Christianity*, 1781; *Elements of Moral Science*, 1790-93. Beattie was unfortunate in his domestic life. His wife, whom he married in 1767, was afflicted with insanity, a disease which she appears to have inherited from her mother. Two sons, all his family, died just as they were attaining manhood. The elder, James H. Beattie, a young man of great promise, who at the age of nineteen had been associated with his father in the professorship, died in 1790. The younger brother died in 1796. Beattie never recovered his second blow. His mind was nearly overthrown by it; his spirit was completely broken, and although he still lectured, he neither wrote nor studied. In 1799 he was attacked with palsy, and continued to suffer from that disease for three years. He died on the 18th August 1803. Beattie's fame rests now solely on his poems. The much celebrated *Essay on Truth* is a work of no philosophic ability, and is disfigured by the violent and intemperate language of the author. His other writings on philosophical subjects, such as the *Elements of Moral Science*, are excessively weak, and have fallen into well-deserved oblivion. *The Minstrel*, however, is a work which will always retain a considerable share of popular favour. The ground-plan is simple and well conceived,—to trace the development of poetic genius in a youth from his earliest years up to the time when he becomes able to take his place as a minstrel. There runs through the poem a fine vein of quiet reflection, interspersed with animated descriptions of natural scenery. The versification is smooth

and melodious. (See *Life of Beattie*, by his friend Sir W. Forbes, 1806.)

**BEAUCAIRE** (i.e., *Bellus Quadrum*, the beautiful square), a town of France, department of Gard, and arrondissement of Nîmes. Lat. 43° 48' 32" N., long. 4° 38' 50" E. It is situated on the right bank of the Rhone, opposite Tarascon, with which it is connected by a magnificent suspension-bridge of four spans and 1456 feet in length. The town is generally well built, but has no public buildings worthy of notice, and the streets are narrow and crooked. Its ancient castle of Bellicadro is now in ruins. It gives name to the canal which communicates with the sea, and also connects it with the Languedoc canal, forming part of the line of communication between the Rhone and the Garonne. It is also connected with Nîmes and Alais by a railway opened in 1839. The manufactures are few and unimportant. The town derives its celebrity from the great July fair, which has been held here annually since the 13th (or 14th) century, and to which merchants come from all parts of Europe, and even from Persia and Armenia. The extensive meadow, called Magdalen's, on the banks of the Rhone, is set apart for the gathering, and almost every kind of article, whether of convenience or luxury, is there exhibited. Though the fair is now less frequented than formerly, it is said that still as many as 100,000 persons attend. There are stone quarries in the neighbourhood of the town, and the manufacture of linen and woollen stuffs is carried on. Population in 1872, 7858.

Beaucaire occupies the site of the ancient *Upernis*, and several remains of the Roman city have been discovered, as well as (in 1734) the road that led from Nîmes. It was a fortress in the Middle Ages, and belonged in succession to the counts of Arles, the archbishops of Arles, the counts of Toulouse, and the viscounts of Narbonne. In the 12th century it is frequently mentioned by the troubadours. Presented in 1215 to Simon de Montfort, it was next year taken possession of by Count Raimund VI.; and in 1226 Louis VIII. made himself master of it. In the wars of the League it suffered severely, and in 1632 its castle was destroyed by Richelieu.

**BEAUCHAMP, ALPHONSE DE**, French historian and man of letters, was born at Monaco in 1767, and died in 1832. In 1784 he entered a Sardinian regiment of marines, but on the outbreak of war with the French Republic, he refused to fight in what he considered an unjust cause, and was imprisoned for several months. After being liberated he took up his residence in Paris, where he obtained a post in one of the Government offices. On the fall of Robespierre, Beauchamp was transferred to the *bureau* of the minister of police, and charged with the superintendance of the press. This situation opened up to him materials of which he made use in his first and most popular historical work, *Histoire de la Vendée et des Chouans*, 3 vols., 1806. The book, received with great favour by the people, was displeasing to the authorities. The third edition was confiscated; its writer was deprived of his post, and in 1809 was compelled to leave Paris and take up his abode in Rheims. In 1811 he obtained permission to return, and again received a Government appointment. This he had to resign on the Restoration, but was rewarded with a small pension, which was continued to his widow after his death.

Beauchamp wrote extensively for the public journals. His historical and biographical works are numerous and important. The best known of them are:—*Histoire de la Conquête du Pérou*, 1807; *Histoire du Brésil*, 1815; *Histoire de la Révolution du Pérou*, 1823; *Vie de Louis XVIII.*, 1821. The *Mémoires de Fouché* have also been ascribed to him.

**BEAUHARNAIS, EUGÈNE DE**, step-son of Napoleon I., was born at Paris, September 3, 1781. His father, the Vicomte Alexander de Beauharnais, had been a member of the National Convention, and for some time commanded the republican army of the north. His want of success in

the field, however, brought him under the suspicion of the Revolutionary leaders; he was tried on a charge of treason, and was executed on 23d June 1794. After the marriage of Napoleon with the Vicomtesse Josephine Beauharnais, her son Eugène accompanied the army of Italy and acted as aide-de-camp to his step-father, by whom he was treated with the greatest affection and favour. He was rapidly promoted; and after the establishment of the empire, was made prince and viceroy of Italy. In 1806 he was adopted by Napoleon. During the great campaign of 1809 he had the command of the Italian army, and by his skilful conduct materially contributed to the success of the emperor. In 1812 he commanded a corps of the grand army; and after the departure of Napoleon and flight of Murat, had the entire charge of the broken French forces. The disastrous campaigns of 1813 and 1814 deprived him of his vicerealty, and he retired to Munich, the capital of the king of Bavaria, whose daughter he had married in 1806. There he continued to reside, with the title of duke of Leuchtenberg, till his death in 1824.

**BEAUMANOIR, PHILIPPE DE**, a distinguished writer on French law, was born in the early part of the 13th century, and died in 1296. The few facts known regarding his life are to be gathered from legal documents in which his name occurs. From these it appears that in 1273 he filled the post of *bailli* at Senlis, and in 1280 held a similar office at Clermont. He is also occasionally referred to as presiding at the assizes held at various towns. His great work is entitled *Coutumes de Beauvoisis*, and was first published by De la Thuassière in 1690. A second edition, with introduction, was published by Beugnot in 1842. It is regarded as one of the best works bearing on old French law, and was frequently referred to with high admiration by Montesquieu.

**BEAUMARCHAIS, PIERRE AUGUSTIN CARON**, better known by his acquired title **DE BEAUMARCHAIS**, the most distinguished French comic dramatist next to Molière, and a man of much importance during the pre-Revolutionary period, was born at Paris in 1732. His father, who was a watchmaker, brought him up to the same trade. He was an unusually precocious and lively boy, shrewd, sagacious, and, like his sisters, passionately fond of music, and imbued with a strong desire for rising in the world. At the age of twenty-one he invented a new escapement for watches, which was pirated by a rival maker. Young Caron at once published his grievance in the newspapers, and had the matter referred to the Academy of Sciences, who decided in his favour. This affair brought him into notice at court; he was appointed, or at least chose to dub himself, watchmaker to the king, who had called him in to examine Mnia. de Pompadour's watch. His handsome figure and cool assurance soon began to make their way at court, where he so earnestly desired to obtain a footing. Nor was it long before his wish was accomplished. The wife of an old court official, conceiving a violent passion for young Caron, persuaded her husband to make over his office to his rival, and on her husband's death, a few months later, married the handsome watchmaker. Caron at the same time assumed the title *De Beaumarchais*; and four years later, by purchasing the office of secretary to the king, obtained a title of nobility.

While employed at court his musical talents brought him under the notice of the king's sisters, who engaged him to teach them the harp. In this way he obtained access to the best society of the court, and by a fortunate accident was enabled to make use of the princesses' friendship to confer a slight favour on the great banker Paris-Duverney. Duverney testified his gratitude in a most substantial manner; he bestowed shares in several of his speculations upon Beaumarchais, and the latter, whose business talents

were of a high order, soon realized a handsome fortune. In 1764 he took a journey to Spain, partly with commercial objects in view, but principally on account of the Clavijo affair, which was afterwards made famous by the Gozman memoirs, and by Goethe's drama. Four years later he made his first essay on the stage with the sentimental drama *Eugénie*, which was followed after an interval of two years by *Les Deux Amis*. Neither had more than moderate success, and it was clear that, though the author might be unaware of it, his strength did not lie in the grave and sentimental. Meantime the clouds of the first great storm in Beaumarchais's life were gathering round him. He was very generally disliked as an upstart, and there were many ready to seize the first opportunity of hurling him from the position he had attained. Duverney, his great benefactor, died in 1770; but some time before his death a duplicate settlement of the affairs between him and Beaumarchais had been drawn up, in which the former acknowledged himself debtor to the latter for 16,000 francs. Duverney's heir, Count la Blache, a bitter enemy of Beaumarchais, denied the validity of this document, though without directly stigmatizing it as a forgery. The matter was put to trial. Beaumarchais gained his cause, but his adversary at once carried the case before the parliament, and in the early part of 1773 that body was preparing to give its decision on the report of one of its members, M. Gozman. Beaumarchais was well-nigh in despair; ruin stared him in the face; he was looked upon not only with dislike but with suspicion and contempt. Worst of all, he was unable to obtain an interview with Gozman, in whose hands his fate rested. At last, just before the day on which the report was to be given in, he was informed privately that, by presenting 200 louis to Mme. Gozman and 15 to her secretary, the desired interview might take place; if the result should prove unfavourable the money would be refunded. The money was sent and the interview obtained; but the decision was adverse, and 200 louis were returned, the 15 going as business expenses to the secretary. Beaumarchais, who had learned that there was no secretary save Mme. Gozman herself, insisted on restitution of the 15 louis, and the lady, in her passion, denied all knowledge of the affair. Her husband, who seems not to have been cognisant of the transaction at first, and who, doubtless, thought the defeated litigant would be easily put down, at once brought an accusation against him in parliament for an attempt to corrupt a judge. The battle was fought chiefly through the *Mémoires*, or reports published by the adverse parties, and in it Beaumarchais's success was most complete. All his best qualities were drawn forth by the struggle; his wit, energy, and cheerfulness seemed to be doubled; and for vivacity of style, fine satire, and broad humour, his famous *Mémoires* have never been surpassed. Even Voltaire was constrained to envy them. Nor was the effect of the struggle apparent only in Beaumarchais himself. He was attacking the parliament through one of its members, and the parliament was the universally detested body formed by the chancellor Maupeou. The *Mémoires* were, therefore, hailed with general delight; and the author, from being perhaps the most unpopular man in France, became at once the idol of the people. The decision in the case, however, so far as law went, was against him. The parliament condemned him *au blâme*,—i.e., to civic degradation; but he obtained restitution of his rights within two years, and finally triumphed over his adversary La Blache.

During the next few years his employment was of a somewhat singular nature. He was engaged by the king in secret service, principally to destroy certain scurrilous pamphlets concerning Mme. du Barry, the publication of which had been threatened. His visits to England, on

these missions, in which he was very successful, led him to take a deep interest in the impending struggle between the colonies and the mother country. His sympathies were entirely with the Americans; and by his unwearied exertions he succeeded in inducing the French Government to give ample, though private, assistance in money and arms to the insurgent colonists. He himself, partly on his own account, partly as an agent, carried on an enormous traffic with America. During the same period he had laid the foundations of a more enduring fame by his two famous comedies, the best of their class since those of Molière. The earlier, *Le Barbier de Séville*, after a short prohibition, was put on the stage in 1775. The first representation was a complete failure. Beaumarchais had overloaded the last scene with allusions to the facts of his own case and the whole action of the piece was laboured and heavy. But with undaunted energy he set to work, cut down and remodelled the piece in time for the second representation, when it achieved a complete success. The intrigues which were necessary in order to obtain a licence for the second and more famous comedy *Le Mariage de Figaro* are highly amusing, and throw much light on the unsettled state of public sentiment at the time. The play was completed in 1781, but the opposition of Louis XVI., who saw its dangerous tendencies, was not overcome till 1784. The comedy had an unprecedented success. The principal character in both plays, the world-famous *Figaro*, is a completely original conception; and for mingled wit, shrewdness, gaiety, and philosophic reflection, may not unjustly be ranked alongside of the great Tartuffe. To English readers the *Figaro* plays are generally known through the adaptations of them in the grand operas of Mozart and Rossini; but in France they long retained popularity as acting pieces. Beaumarchais's later productions, the bombastic opera *Tarare*, and the drama *The Guilty Mother*, which was very popular, are hardly worthy of his genius.

By his writings Beaumarchais contributed greatly, though quite unconsciously, to hurry on the events that led to the Revolution. At heart he hardly seems to have been a republican, and the new state of affairs did not benefit him. His popularity had been somewhat lessened by the affairs Bergasse and Mirabeau, and his great wealth and splendid mansion exposed him to the enmity of the envious. A speculation into which he entered, to supply the Convention with muskets from Holland, proved a ruinous failure. He was charged with treason to the Republic, and was obliged for some time to take refuge in Holland and England. His memoirs entitled, *Mes Six Époques*, detailing his sufferings under the Republic, are not unworthy of the Gozman period. His courage and happy disposition never deserted him; he was gay and hopeful up to the time of his death, which took place suddenly in May 1799.

Loménie, *Beaumarchais et son Temps*, 1856; Eng. trans. of the same by H. S. Edwards, 4 vols., 1856. Beaumarchais's works have been published by Gudin, 7 vols., 1809; and by Furne, 6 vols., 1827.

**BEAUMARIS** (formerly *Bornovor*, and deriving its present French name of *Beau Marais* from Edward I.), a borough and market-town of Anglesea, North Wales. It is situated on the Bay of Beaumaris, at the northern entrance of the Menai Straits, in lat. 53° 16' N., long. 4° 5' W. The town consists of several streets; and at the extremity of the principal one stands the castle. This fortress was built by Edward I. about 1295. It covers a great extent of ground, but its imposing effect is somewhat lessened by its low position, which was so designed that the fosse might communicate with the sea, so that vessels might unload beneath the walls. The chapel, dedicated to



the Virgin, is a spacious structure, containing several fine monuments. A free school was founded here in 1603. The principal buildings are the town-hall, county hall, prison, custom-house, assembly-room, and national school. Beaumaris has no manufactures and comparatively little

trade, but is much frequented as a bathing-place. It unites with Holyhead, Amlwch, and Llangefni in returning a member to parliament. The bay affords good anchorage, having seven fathoms of water at the lowest ebb. Population in 1871, 2291.

## BEAUMONT AND FLETCHER

THE critical memoir prefixed by Mr Dyce to the only good and scholar-like edition of Beaumont and Fletcher has summed up once for all, in fulness of perfect order, what little can now be known of their lives. It may suffice here to extract from this complete and careful record a few main facts and necessary dates, taking as little note as need be of any supplementary or hypothetical matters. Six or seven years before the birth of his brother in art, John Fletcher was born in December 1579 at Rye in Sussex, and baptized on the 20th of the same month. Richard Fletcher, his father, afterwards queen's chaplain, dean of Peterborough, and bishop successively of Bristol, Worcester, and London, was then minister of the parish in which the son was born who was to make their name immortal. That son was just turned of seven when the dean distinguished and disgraced himself as the spiritual tormentor of the last moments on earth of Mary Stuart. When not quite twelve he was admitted pensioner of Bene't College, Cambridge, and two years later was made one of the Bible-clerks: of this college Bishop Fletcher had been president twenty years earlier, and six months before his son's admission had received from its authorities a first letter of thanks for various benefactions, to be followed next year by a second. Four years later than this, when John Fletcher wanted five or six months of his seventeenth year, the bishop died suddenly of over much tobacco and the displeasure of Queen Elizabeth at his second marriage,—this time, it appears, with a lady of such character as figures something too frequently on the stage of his illustrious son. He left eight children by his first marriage in such distress that their uncle, Dr Giles Fletcher, author of a treatise on the Russian commonwealth which is still held in some repute, was obliged to draw up a petition to the queen on their behalf, which was supported by the intercession of Essex, but with what result is uncertain. From this date we know nothing of the fortunes of John Fletcher, till the needy orphan boy of seventeen reappears as the brilliant and triumphant poet whose name is linked for all time with the yet more glorious name of Francis Beaumont, third and youngest son of Sir Francis Beaumont of Grace-Dieu, one of the justices of the Common Pleas,—born, according to general report, in 1586, but, according to more than one apparently irrefragable document, actually born at least a year earlier. The first record of his existence is the entry of his name, together with those of his elder brothers Henry and John, as a gentleman-commoner of Broadgates Hall, Oxford, now supplanted by Pembroke College. But most lovers of his fame will care rather to remember the admirable lines of Wordsworth on the "eager child" who played among the rocks and woodlands of Grace-Dieu; though it may be doubted whether even the boy's first verses were of the peaceful and pastoral character attributed to them by the great laureate of the lakes. That passionate and fiery genius which was so soon and for so short a time to "shake the buckined stage" with heroic and tragic notes of passion and of sorrow, of scorn and rage and alighted love and jealousy, must surely have sought vent from the first in fancies of a more ardent and ambitious kind; and it would be a likelier conjecture that when Frank Beaumont (as we know on more authorities than one that he was always called by

his contemporaries, even in the full flush of his adult fame—"never more than Frank," says Heywood) went to college at the ripe age of twelve, he had already committed a tragedy or two in emulation of *Tamburlaine*, *Andronicus*, or *Jeronymo*. The date of his admission was 4th February 1597; on April 22d of the following year his father died; and on the 3d of November 1600, having left Oxford without taking his degree, the boy of fifteen was entered a member of the Inner Temple, his two brothers standing sponsors on the grave occasion. But the son of Judge Beaumont was no fitter for success at the bar than the son of Bishop Fletcher for distinction in the church: it is equally difficult to imagine either poet invested with either gown. Two years later appeared the poem of *Salmacis and Hermaphrodite*, a voluptuous and voluminous expansion of the Ovidian legend, not on the whole discreditably to a lad of seventeen, fresh from the popular love-poems of Marlowe and Shakespeare, which it naturally exceeds in long-winded and fantastic diffusion of episodes and conceits. At twenty-two Beaumont prefixed to the magnificent masterpiece of Ben Jonson some noticeable verses in honour of his "dear friend" the author; and in the same year (1607) appeared the anonymous comedy of *The Woman-Hater*, usually assigned to Fletcher alone; but being as it is in the main a crude and puerile imitation of Jonson's manner, and certainly more like a man's work at twenty-two than at twenty-eight, internal evidence would seem to justify, or at least to excuse, those critics who in the teeth of high authority and tradition would transfer from Fletcher to Beaumont the principal responsibility for this first play that can be traced to the hand of either. As Fletcher also prefixed to the first edition of *Volpone* a copy of commendatory verses, we may presume that their common admiration for a common friend was among the earliest and strongest influences which drew together the two great poets whose names were thenceforward to be for ever indivisible. During the dim eleven years between the death of his father and the dawn of his fame, we cannot but imagine that the career of Fletcher had been unprosperous as well as obscure. From seventeen to twenty-eight his youth may presumably have been spent in such painful struggles for success, if not for sustenance, as were never known to his younger colleague, who, as we have seen, was entered at Oxford a few months after Fletcher must in all likelihood have left Cambridge to try his luck in London; a venture most probably resolved on as soon as the youth had found his family reduced by the father's death to such ruinous straits that any smoother course can hardly have been open to him. Entering college at the same age as Fletcher had entered six years earlier, Beaumont had before him a brighter and briefer line of life than his elder. But whatever may have been their respective situations when, either by happy chance or, as Mr Dyce suggests, by the good offices of Jonson, they were first brought together, their intimacy soon became so much closer than that of ordinary brothers that the household which they shared as bachelors was conducted on such thoroughly communistic principles as might have satisfied the most trenchant theorist who ever proclaimed, as the cardinal point of his doctrine, a complete and absolute community of bed and board, with

all goods thereto appertaining. But in the year following that in which the two younger poets had united in homage to Jonson, they had entered into a partnership of more importance than this in "the same clothes and cloak, &c.," with other necessaries of life specified by Aubrey. In 1608, if we may trust the reckoning which seems trustworthiest, the twin stars of our stage rose visibly together for the first time. The loveliest, though not the loftiest, of tragic plays that we owe to the comrades or the successors of Shakespeare, *Philaster*, has always been regarded as the first-born issue of their common genius. The noble tragedy of *Thierry and Theodoret* has generally been dated earlier and assigned to Fletcher alone; but we can be sure neither of the early date nor the single authorship. The main body of the play, comprising both the great scenes which throw out into full and final relief the character of either heroine for perfect good or evil, bears throughout the unmistakable image and superscription of Fletcher; yet there are parts which for gravity and steady strength of style, for reserve and temperance of effect, would seem to suggest the collaboration of a calmer and more patient hand; and these more equable and less passionate parts of the poem recall rather the touch of Massinger than of Beaumont. In the second act, for example, the regular structure of the verse, the even scheme of the action, the exaggerated braggardism which makes of the hero a mere puppet or mouthpiece of his own self-will, are all qualities which, for better or for worse, remind us of the strength or the weakness of a poet with whom we know that Fletcher, before or after his alliance with Beaumont, did now and then work in common. Even the Arbaces of Beaumont, though somewhat too highly coloured, does not "write himself down an ass," like Thierry on his first entrance, after the too frequent fashion of Massinger's braggarts and tyrants; does not proclaim at starting or display with mere wantonness of exposure his more unlovely qualities in the naked nature of their deformity. Compare also the second with the first scene of the fourth act. In style and metre this second scene is as good an example of Massinger as the first is of Fletcher at his best. Observe especially in the elaborate narrative of the pretended self-immolation of Ordella these distinctive notes of the peculiar style of Massinger; the excess of parenthetical sentences, no less than five in a space of twenty lines; the classical common-places of allusion to Athens, Rome, and Sparta in one superfluous breath; the pure and vigorous but somewhat level and prosaic order of language, with the use of certain cheap and easy phrases familiar to Massinger as catchwords; the flat and feeble terminations by means of which the final syllable of one verse runs on into the next without more pause or rhythm than in a passage of prose; the general dignity and gravity of sustained and measured expression. These are the very points in which the style of Massinger differs from that of Fletcher; whose lightest and loocest verses do not overlap each other without sensible distinction between the end of one line and the beginning of the next; who is often too fluent and facile to be choice or forcible in his diction, but seldom if ever prosaic or conventional in phrase or allusion, and by no means habitually given to weave thoughts within thoughts, knit sentence into sentence, and hang whole paragraphs together by the help of loops and brackets. From these indications we might infer that this poem belongs altogether to a period later than the death of Beaumont; though even during his friend's life it appears that Fletcher was once at least allied with Massinger and two lesser dramatists in the composition of some play now unknown to men.

Hardly eight years of toil and triumph, of joyous and glorious life, were spared by destiny to the younger poet

between the date assigned to the first radiant revelation of his genius in *Philaster* and the date which marks the end of all his labours. On the 6th of March 1616 Francis Beaumont died,—according to Jonson and tradition, "ere he was thirty years of age," but this we have seen to be inconsistent with the registry of his entrance at Oxford. If we may trust the elegiac evidence of friends, he died of his own genius and fiery overwork of brain; yet from the magnificent and masculine beauty of his portrait one should certainly never have guessed that any strain of spirit or stress of invention could have worn out so long before its time so fair and royal a temple for so bright and affluent a soul. A student of physiognomy will not fail to mark the points of likeness and of difference between the faces of the two friends; both models of noble manhood, handsome and significant in feature and expression alike;—Beaumont's the statelier and serener of the two, with clear thoughtful eyes, full arched brows, and strong aquiline nose, with a little cleft at the tip; a grave and beautiful mouth, with full and finely curved lips; the form of face a long pure oval, and the imperial head with its "fair large front" and clustering hair set firm and carried high with an aspect at once of quiet command and kingly observation; Fletcher's a more keen and fervid face, sharper in outline every way, with an air of bright ardour and glad fiery impatience; sanguine and nervous, suiting the complexion and colour of hair; the expression of the eager eyes and lips almost recalling that of a noble hound in act to break the leash it strains at;—two heads as lordly of feature and as expressive of aspect as any gallery of great men can show. That spring of 1616, we may note in passing, was the darkest that ever dawned upon England or the world; for, just forty-eight days afterwards, it witnessed, on the 23d of April, the removal from earth of the mightiest genius that ever dwelt among men. Scarcely more than a month and a half divided the death-days of Beaumont and of Shakespeare. Some three years earlier by Mr Dyce's estimate, when about the age of twenty-eight, Beaumont had married Ursula, daughter and coheires to Henry Iley of Sundridge in Kent, by whom he left two daughters, one of them posthumous. Fletcher survived his friend just nine years and five months; he died "in the great plague, 1625," and was buried on the 29th of August in St Saviour's, Southwark; not, as we might have wished, beside his younger fellow in fame, who but three days after his untimely death had added another deathless memory to the graves of our great men in Westminster Abbey, which he had sung in such noble verse. Dying when just four months short of forty-six, Fletcher had thus, as well as we can now calculate, altogether some fourteen years and six months more of life than the poet who divides with him the imperial inheritance of their common glory.

The perfect union in genius and in friendship which has made one name of the two names of these great twin brothers in song is a thing so admirable and so delightful to remember, that it would seem ungracious and unkindly to claim for either a precedence which we may be sure he would have been eager to disclaim. But if a distinction must be made between the Dioscouri of English poetry, we must admit that Beaumont was the twin of heavenlier birth. Only as Pollux was on one side a demigod of diviner blood than Castor can it be said that on any side Beaumont was a poet of higher and purer genius than Fletcher; but so much must be allowed by all who have eyes and ears to discern in the fabric of their common work a distinction without a difference. Few things are stranger than the avowal of so great and exquisite a critic as Coleridge, that he could trace no faintest line of demarcation between the plays which we owe mainly to Beaumont

and the plays which we owe solely to Fletcher. To others this line has always appeared in almost every case unmitigable. Were it as hard and broad as the line which marks off, for example, Shakespeare's part from Fletcher's in *The Two Noble Kinsmen*, the harmony would of course be lost which now informs every work of their common genius, and each play of their writing would be such another piece of magnificent patchwork as that last gigantic heir of Shakespeare's invention, the posthumous birth of his parting Muse which was suckled at the breast of Fletcher's as a child of godlike blood might be reared on the milk of a mortal mother—or in this case, we might sometimes be tempted to say, of a she-goat who left in the veins of the heaven-born suckling somewhat too much of his nurse Amalthea. That question however belongs in any case more properly to the study of Shakespeare than to the present subject in hand. It may suffice here to observe that the contributions of Fletcher to the majestic temple of tragedy left incomplete by Shakespeare show the lesser workman almost equally at his best and at his worst, at his weakest and at his strongest. In the plays which we know by evidence surer than the most trustworthy tradition to be the common work of Beaumont and Fletcher, there is indeed no trace of such incongruous and incompatible admixture as leaves the greatest example of romantic tragedy—for *Cymbeline* and the *Winter's Tale*, though not guiltless of blood, are in their issues no more tragic than *Pericles* or the *Tempest*—an unique instance of glorious imperfection, a hybrid of heavenly and other than heavenly breed, disproportioned and divina. But throughout these noblest of the works inscribed generally with the names of both dramatists we trace on every other page the touch of a surer hand, we hear at every other turn the note of a deeper voice, than we can ever recognize in the work of Fletcher alone. Although the beloved friend of Jonson, and in the field of comedy his loving and studious disciple, yet in that tragic field where his freshest bays were gathered Beaumont was the worthiest and the closest follower of Shakespeare. In the external but essential matter of expression by rhythm and metre he approves himself always a student of Shakespeare's second manner, of the style in which the graver or tragic part of his historical or romantic plays is mostly written; doubtless, the most perfect model that can be studied by any poet who, like Beaumont, is great enough to be in no danger of sinking to the rank of a mere copyist, but while studious of the perfection set before him is yet conscious of his own personal and proper quality of genius, and enters the presence of the master not as a servant but as a son. The general style of his tragic or romantic verse is as simple and severe in its purity of note and regularity of outline as that of Fletcher's is by comparison lax, effusive, exuberant. The matchless fluency and rapidity with which the elder brother pours forth the stream of his smooth swift verse gave probably the first occasion for that foolish rumour which has not yet fallen duly silent, but still murmurs here and there its suggestion that the main office of Beaumont was to correct and contain within bounds the over-flowing invention of his colleague. The poet who while yet a youth had earned by his unaided mastery of hand such a crown as was bestowed by the noble love and the loving "envy" of Ben Jonson was, according to this tradition, a mere precocious pedagogue, fit only to revise and restrain the too liberal effusions of his elder in genius as in years. Now, in every one of the plays common to both, the real difficulty for a critic is not to trace the hand of Beaumont, but to detect the touch of Fletcher. Throughout the better part of every such play, and above all of their two masterpieces, *Philaster* and *The Maid's Tragedy*, it should be clear to the most sluggish or surly of readers that he has not to do with the author of

*Valentinian* and *The Double Marriage*. In those admirable tragedies the style is looser, more fluid, more feminine. From the first scene to the last we are swept as it were along the race of a running river, always at full flow of light and buoyant melody, with no dark reaches or perilous eddies, no stagnant pools or sterile sandbanks; its bright course only varied by sudden rapids or a stronger ripple here and there, but in rough places or smooth still stirred and sparkling with summer wind and sun. But in those tragic poems of which the dominant note is the note of Beaumont's genius a subtler chord of thought is sounded, a deeper key of emotion is touched, than ever was struck by Fletcher. The lighter genius is palpably subordinate to the stronger, and loyally submits itself to the impression of a loftier spirit. It is true that this distinction is never grave enough to produce a discord: it is also true that the plays in which the predominance of Beaumont's mind and style is generally perceptible make up altogether but a small section of the work that bears their names conjointly; but it is no less true that within this section the most precious part of that work is comprised. Outside it we shall find no figures so firmly drawn, no such clearness of outline, no such cunning of hands as we recognize in the three great studies of Bellario, Evadne, and Aspatia. In his male characters, as for instance in the parts of Philaster and Arbaces, Beaumont also is apt to show something of that exaggeration or inconsistency for which his colleague is perhaps more frequently and more heavily to blame; but in these there is not a jarring note, not a touch misplaced; unless, indeed, a rigid criticism may condemn as unfeminine and incongruous with the gentle beauty of her pathetic patience the device by which Aspatia procures herself the death desired at the hand of Amintor. This is noted as a fault by Mr Dyce; but may well be forgiven for the sake of the magnificent scene which follows, and the highest tragic effect ever attained on the stage of either poet. That this as well as the greater part of those other scenes which are the glory of the poem is due to Beaumont might readily be shown at length by the process of comparison. The noble scene of regicide, which it was found expedient to cancel during the earlier years of the Restoration, may indeed be the work of Fletcher; but the part of Evadne must undoubtedly be in the main assigned to the more potent hand of his fellow. There is a fine harmony of character between her naked audacity in the second act and her fierce repentance in the fourth, which is not unworthy a disciple of the tragic school of Shakespeare; Fletcher is less observant of the due balance, less heedful of the nice proportions of good and evil in a faulty and fiery nature, compounded of perverse instinct and passionate reaction. From him we might have had a figure as admirable for vigour of handling, but hardly in such perfect keeping as this of Beaumont's Evadne, the murderess-Magdalen, whose penitence is of one crimson colour with her sin. Nor even in Fletcher's Ordella, worthy as the part is throughout even of the precious and exquisite praise of Lamb, is there any such cunning touch of tenderness or delicate perfume of pathos as in the parts of Bellario and Aspatia. These have in them a bitter sweetness, a subtle pungency of mortal sorrow and tears of divine delight, beyond the reach of Fletcher. His highest studies of female character have dignity, energy, devotion of the heroic type; but they never touch us to the quick, never waken in us any finer and more profound sense than that of applause and admiration. There is a modest pathos now and then in his pictures of feminine submission and slighted or outraged love; but this submission he is apt to make too servile, this love too dog-like in its abject devotion to retain that tender reverence which so many generations of readers have paid to the sweet memories of

Aspatia and Bellario. To excite compassion was enough for Fletcher, as in the masculine parts of his work it was enough for him to excite wonder, to sustain curiosity, to goad and stimulate by any vivid and violent means the interest of readers or spectators. The single instance of noble pathos, the one scene he has left us which appeals to the higher and purer kind of pity, is the death of the child Hengo in *Bonduca*,—a scene which of itself would have sufficed to enrol his name for ever on the list of our great tragic poets. To him we may probably assign the whole merit of that fiery and high-toned tragedy, with all its spirit and splendour of national and martial passion; the conscious and demonstrative exchange of courtesy between Roman and Briton, which is one of the leading notes of the poem, has in it a touch of overstrained and artificial chivalry characteristic of Fletcher; yet the parts of Caratach and Pœnius may be counted among the loftiest and most equal of his creations. But no surer test or better example can be taken of the distinctive quality which denotes the graver genius of either poet than that supplied by a comparison of Beaumont's *Triumph of Love* with Fletcher's *Triumph of Death*. Each little play, in the brief course of its single act, gives proof of the peculiar touch and special trick of its author's hand: the deeper and more delicate passion of Beaumont, the rapid and ardent activity of Fletcher, have nowhere found a more noticeable vent for the expression respectively of the most tender and profound simplicity of quiet sweetness, the most buoyant and impatient energy of tragic emotion.

In the wider field of their comic or romantic drama it is yet easier to distinguish the respective work of either hand. The bias of Fletcher was towards mixed comedy; his lightest and wildest humour is usually crossed or tempered by an infusion of romance; like Shakespeare in this one point at least, he has left no single play without some touch on it of serious interest, of poetic eloquence or fancy, however slight and fugitive. Beaumont, evidently under the imperious influence of Ben Jonson's more rigid theories, seems rather to have bent his genius with the whole force of a resolute will into the form or mould prescribed for comedy by the elder and greater comic poet. The admirable study of the worthy citizen and his wife, who introduce to the stage and escort with their applause *The Knight of the Burning Pestle* through his adventurous career to its untimely end, has all the force and fulness of Jonson's humour at its best, with more of freshness and freedom. In pure comedy, varied with broad farce and mock-heroic parody, Beaumont was the earliest as well as the ablest disciple of the master whose mantle was afterwards to be shared among the academic poets of a younger generation, the Randolphs and Cartwrights who sought shelter under the shadow of its voluminous folds. The best example of the school of Jonson to be found outside the ample range of his own work is *The Scornful Lady*, a comedy whose exceptional success and prolonged popularity must have been due rather to the broad effect of its forcible situations, its wealth and variety of ludicrous incidents, and the strong gross humour of its dialogue, than to any finer quality of style, invention, or character. It is the only work of Beaumont and Fletcher which a critic who weighs the meaning of his words can admit to be as coarse as the coarsest work of Ben Jonson. They are prone, indeed, to indulge elsewhere in a wanton and exuberant licence of talk; and Fletcher, at least, is liable to confuse the shades of right and wrong, to deface or efface the boundary lines of good and evil, to stain the ermine of virtue and palliate the nakedness of vice with the same indecorous and incongruous laxity of handling. Often, in mere haste to despatch the business of a play, to buddle up a catastrophe or throw out some particular scene

into sharp and immediate relief, he will sacrifice all seemliness and consistency of character to the present aim of stage effect, and the instant impression of strong incident or audacious eloquence. His heroines are too apt to utter sentiments worthy of Diana in language unworthy of Doll Tear-sheet. But in this play both style and sentiment are throughout on a lower level, the action and emotion are of a baser kind than usual; the precept of Aristotle and the practice of Jonson have been so carefully observed and exaggerated that it might almost be said to offer us in one or two places an imitation not merely of the sorrier but of the sorriest qualities of human nature; and full as it is of spontaneous power and humorous invention, the comedy extolled by the moral Steele (with just so much of reservation as permits him to deprecate the ridicule cast upon the clerical character) is certainly more offensive to artistic law and æsthetic judgment by the general and ingrained coarseness of its tone, than the tragi-comedy denounced by the immortal Dryden as exceeding in licence his own worst work and that of his fellow playwrights; an imputation, be it said in passing, as groundless as the protest pleaded on their behalf is impudent; for though we may hardly agree with the uncompromising panegyrist who commends that play in particular to the approval of "the austere scarlet" (remembering, perhaps, that Aristophanes was the chosen bedfellow of Chrysostom), there is at least no such offence against art or taste in the eccentricity of its situations or the daring of its dialogue. The buoyant and facile grace of Fletcher's style carries him lightly across quagmires in which a heavier-footed poet, or one of slower tread, would have stuck fast, and come forth bemired to the knees. To Beaumont his stars had given as birthright the gifts of tragic pathos and passion, of tender power, and broad strong humour; to Fletcher had been allotted a more fiery and fruitful force of invention, a more aerial ease and swiftness of action, a more various readiness and fulness of bright exuberant speech. The genius of Beaumont was deeper, sweeter, nobler than his elder's: the genius of Fletcher more brilliant, more supple, more prodigal, and more voluble than his friend's. Without a taint or a shadow on his fame of such imitative servility as marks and degrades the mere henchman or satellite of a stronger poet, Beaumont may fairly be said to hold of Shakespeare in his tragedy, in his comedy of Jonson; in each case rather as a kinsman than as a client, as an ally than as a follower: but the more special province of Fletcher was a land of his own discovering, where no later colonist has ever had power to settle or to share his reign. With the mixed or romantic comedy of Shakespeare it has nothing in common except the admixture or alternation of graver with lighter interest, of serious with humorous action. Nothing is here of his magic-exaltation or charm of fairy empire. The rare and rash adventures of Fletcher on that forbidden track are too sure to end in pitiful and shameful failure. His crown of praise is to have created a wholly new and wholly delightful form of mixed comedy or dramatic romance, dealing merely with the humours and sentiments of men, their passions and their chances; to have woven of all these a web of emotion and event with such gay dexterity, to have blended his colours and combined his effects with such exquisite facility and swift light sureness of touch, that we may return once and again from those heights and depths of poetry to which access was forbidden him, ready as ever to enjoy as of old the fresh incomparable charm, the force and ease and grace of life, which fill and animate the radiant world of his romantic invention. Neither before him nor after do we find, in this his special field of fancy and of work, more than shadows or echoes of his coming or departing genius. Admirable as are his

tragedies already mentioned, rich in splendid eloquence and strong in large grasp of character as is the Roman history of *The False One*, full of interest and vigour as is the better part of *Rollo Duke of Normandy*, and sublime in the loveliness of passion as is the one scene of perfect beauty and terror which crowns this latter tragedy, Fletcher may claim a yet higher and more special station among his great dramatic peers by right of his comic and romantic than by right of his tragic and historic plays. Even in these he is more a romantic than a tragic poet. The quality of his genius, never sombre or subtle or profound, bears him always towards fresh air and sunshine. His natural work is in a midday world of fearless boyish laughter and hardly bitter tears. There is always more of rainbow than of storm in his skies; their darkest shadow is but a tragic twilight. What with him is the noon of night would seem as sunshine on the stage of Ford or Webster. There is but one passage in all these noble plays which lifts us beyond a sense of the stage, which raises our admiration out of speech into silence, tempers and transfigures our emotion with a touch of awe. And this we owe to the genius of Beaumont, exalted for an instant to the very tone and manner of Shakespeare's tragedy, when Amintor stands between the dead and the dying woman whom he has unwittingly slain with hand and tongue. The first few lines that drop from his stricken lips are probably the only verses of Beaumont or Fletcher which might pass for Shakespeare's even with a good judge of style—

"This earth of mine doth tremble," &c.

But in Fletcher's tragedy, however we may be thrilled and kindled with high contagious excitement, we are never awed into dumb delight or dread, never pierced with any sense of terror or pity too deep or even deep enough for tears. Even his Brunhilde and Martias can hardly persuade us to forget for the moment that "they do but jest, poison in jest." A critic bitten with the love of classification might divide those plays of Fletcher usually ranked together as comedies into three kinds: the first he would class under the head of pure comedy, the next of heroic or romantic drama, the third of mixed comedy and romance; in this, the last and most delightful division of the poet's work the special qualities of the two former kinds being equally blended and delicately harmonized. The most perfect and triumphant examples of this class are *The Spanish Curate*, *Monsieur Thomas*, *The Custom of the Country*, and *The Elder Brother*. Next to these, and not too far below them, we may put *The Little French Lawyer* (a play which in its broad conception of a single eccentric humour suggests the collaboration of Beaumont and the influence of Jonson, but in style and execution throughout is perfect Fletcher), *The Humorous Lieutenant* (on which an almost identical verdict might be passed), *Women Pleas'd*, *Beggars Bush*, and perhaps we might add *The Fair Maid of the Inn*; in most if not in all of which the balance of exultant and living humour with serious poetic interest of a noble and various kind is held with even hand and the skill of a natural master. In pure comedy *Rule a Wife and Have a Wife* is the acknowledged and consummate masterpiece of Fletcher. Next to it we might class, for comic spirit and force of character, *Wit without Money*, *The Wildgoose Chase*, *The Chances*, and *The Noble Gentleman*,—a broad poetic farce to whose overflowing fun and masterdom of extravagance no critic has ever done justice but Leigh Hunt, who has ventured, not without reason, to match its joyous and preposterous audacities of superlative and sovereign foolery with the more sharp-edged satire and practical merriment of *King and no King*, where the keen prosaic humour of Bessus and his swordsmen is as typical of the comic style in which Beaumont had been

trained up under Ben Jonson as the high interest and graduated action of the serious part of the play are characteristic of his more earnest genius. Among the purely romantic plays of Fletcher, or those in which the comic effect is throughout subordinate to the romantic, *The Knight of Malta* seems most worthy of the highest place for the noble beauty and exaltation of spirit which informs it with a lofty life, for its chivalrous union of heroic passion and Catholic devotion. This poem is the fairest and the first example of those sweet fantastic paintings in rose-colour and azure of visionary chivalry and ideal holiness, by dint of which the romances of more recent days has sought to cast the glamour of a mirage over the darkest and deadliest "ages of faith." The pure and fervent eloquence of the style is in perfect keeping with the high romantic interest of character and story. In the same class we may rank among the best samples of Fletcher's workmanship *The Pilgrim*, *The Loyal Subject*, *A Wife for a Month*, *Lov's Pilgrimage*, and *The Lover's Progress*,—rich all of them in exquisite writing, in varied incident, in brilliant effects and graceful or passionate interludes. In *The Coxcomb* and *The Honest Man's Fortune*—two plays which, on the whole, can hardly be counted among the best of their class—there are tones of homelier emotion, touches of a simpler and more pathetic interest than usual; and here, as in the two admirable first scenes between Leucippus and Bacha, which relieve and redeem from contempt the tragic burlesque of *Cupid's Revenge*, the note of Beaumont's manner is at once discernible.

Even the most rapid revision of the work done by these great twin poets must impress every capable student with a sense of the homage due to this living witness of their large and liberal genius. The loss of their names from the roll of English poetry would be only less than the loss of the few greatest inscribed on it. Nothing could supply the want of their tragic, their comic or romantic drama; no larger or more fiery planet can ever arise to supplant or to eclipse the twin lights of our zodiac. Whatever their faults of shortcoming or excess, there is in their very names or the mere thought of their common work a kind of special and personal attraction for all true lovers of high dramatic poetry. There is the glory and grace of youth in all they have left us; if there be also somewhat too much of its graceless as well as its gracious qualities, yet there hangs about their memory as it were a music of the morning, a breath and savour of bright early manhood, a joyous and vigorous air of free life and fruitful labour, which might charm asleep for ever all thought or blame of all mortal infirmity or folly, or any stain of earth that may have soiled in passing the feet of creatures half human and half divine while yet they dwelt among men. For good or for evil, they are above all things poets of youth; we cannot conceive of them grown grey in the dignity of years, venerable with the authority of long life, and weighted with the wisdom of experience. In the Olympian circle of the gods and the giants of our race who on earth were their contemporaries and rivals, they seem to move among the graver presences and figures of sedate fame like the two spoilt boys of heaven, lightest of foot and heart and head of all the brood of deity. Shakespeare may have smiled as Jonson may have nodded approval of their bright swift work, neither of these great elders grudging his praise to the special charm which won for it a preference during one generation at least even over their own loftier and weightier verse; and indeed the advance in natural ease, in truth and grace of dialogue, is alike manifest whether we turn to such of their comic characters as Valentine and Don John, Rutilio and Monsieur Thomas, from the Truewit of Jonson or even from the Mercutio of Shakespeare; the one too stiff with classic starch, the

other too full of mere verbal catches and forced conceits, to persuade us that either can in any age have fairly represented the light free talk and facile humour of its youth. In another field than this Beaumont and Fletcher hold as high and secure a station of their own as any poet of their race. In perfect workmanship of lyrical jewellery, in perfect bloom and flower of song-writing, they equal all compeers whom they do not excel; the blossoms of their growth in this kind may be matched for colour and fragrance against Shakespeare's, and for morning freshness and natural purity of form exceed the finest grafts of Jonson. *The Faithful Shepherdess* alone might speak for Fletcher on this score, being as it is simply a lyric poem in semi-dramatic shape, to be judged only as such, and as such almost faultless; but in no wise to be classed for praise or blame among the acting plays of its author, whose one serious error in the matter was the submission of his Dryad to the critical verdict of an audience too probably in great part composed of clowns and satyrs far unlike the loving and sweet-tongued sylvan of his lovely fancy. And whether we assign to him or to Beaumont the divine song of melancholy (*mœstius lacrymis Simonideis*), perfect in form as Catullus and profound in sentiment as Shelley, which Milton himself could but echo and expand, could not heighten or deepen its exquisite intensity of thought and word alike, there will remain witness enough for the younger brother of a lyric power as pure and rare as his elder's.

The excess of influence and popularity over that of other poets usually ascribed to the work of Beaumont and Fletcher for some half century or so after their own time has perhaps been somewhat overstated by tradition. Whatever may have been for a season the fashion of the stage, it is certain that Shakespeare can show two editions for one against them in folio; four in all from 1623 to 1685, while they have but their two of 1647 and 1679. Nor does one see how it can accurately or even plausibly be said that they were in any exact sense the founders of a school either in comedy or in tragedy. Massinger, for some years their survivor, and in some points akin to them as a workman, cannot properly be counted as their disciple; and no leading poet of the time had so much in common with them as he. At first sight, indeed, his choice of romantic subject and treatment of foreign stories, gathered from the fertile tale-tellers of the south, and ranging in date from Boccaccio to Cervantes, may seem to mark him out as a member of the same school; but the deepest and most distinctive qualities of his genius set it far apart from theirs; though undoubtedly not so far that any discrepancy or discord should impair the excellence or injure the keeping of works in which he took part with Fletcher. Yet, placed beside theirs, the tone of his thought and speech seems by comparison severe as well as sober, and sad as well as severe. Their extravagant and boyish insanity of prostrate royalism is not more alien from his half pensive and

half angry undertone of political protest than his usually careful and complete structure of story from their frequently lax and slovenly incoherence of character or plot, than his well composed and proportioned metro from their lighter and looser melodies, than the bitter insistence and elaborate acrimony of his judicial satire on hypocrisy or oppression from the gaiety or facility of mood which suffers them in the shifting of a scene to redeem their worst characters by some juggler's trick of conversion at the last moment allowed them to wind up a play with universal reconciliation and an act of oblivion on all hands. They could hardly have drawn with such steady skill and explicit finish an *Overreach* or a *Luke*; but the strenuous and able work of Massinger at its highest point of success has no breath in it of their brighter and more immediate inspiration. Shirley, on the other hand, may certainly be classed as a pupil who copied their style in water-colour; his best tragedy and his best comedy, *The Traitor* and *The Lady of Pleasure*, might pass muster undetected among the plays of Fletcher, and might fairly claim to take rank above the lowest class of these. In the finest work of Middleton we recognize an almost exact reproduction of Fletcher's metrical effects,—a reverberation of that flowing music, a reiteration of those feminine final notes. In his later tragi-comedies, throughout his masterpiece of *Women beware Women*, and in the noble scenes which make up the tragic or serious part of *The Changeling* or *The Spanish Gypsy*,—wherever, in a word, we find the admirable but unequal genius of this poet at its best—we find a likeness wholly wanting in his earlier and ruder work, which undoubtedly suggests the influence of Fletcher. Other instances of imitation, other examples of discipleship, might perhaps be found among lesser men of the next generation; but the mass of succeeding playwrights began in a very short time to lower the style and debase the scheme of dramatic poetry; and especially to loosen the last ties of harmony, to deface the very form and feature of tragic verse. In Shirley, the last and least of those in whom the lineal blood of the old masters was yet discernible, we find side by side with the fine ancestral indications of legitimate descent exactly such marks of decadence rather than degeneracy as we might have anticipated in the latest heir of a long line which began with the rise of Marlowe, "son of the morning," in the highest heaven of our song, to prepare a pathway for the sun. After Shakespeare there was yet room for Beaumont and Fletcher; but after these and the other constellations had set, whose lights filled up the measure of that diviner zodiac through which he moved, there was but room in heaven for the pallid moonrise of Shirley; and before this last reflex from a sunken sun was itself eclipsed, the glory had passed away from our drama, to alight upon that summit of epic song whence Milton held communion with darkness and the stars.

(A. C. A.)

BEAUNE, the chief town of an arrondissement in France, in the department of Côte-d'Or, situated on the River Bourzeoise, twenty-three miles S.S.W. of Dijon, on the railway from Paris to Lyons. The town is of poor appearance, but has several buildings of interest, such as the churches of Notre Dame and Saint Pierre, both of the 12th century, the hospital, founded by Nicholas Rollin in 1443, and the belfry of the old town-house. Of more modern erection are the public baths, the theatre, the communal college, and the library. In the 18th century there were no fewer than seven monastic buildings in the town besides a Bernardine abbey, a Carthusian convent,

and a society of priests engaged in educational pursuits. Beaune enjoys considerable commercial prosperity as the principal seat of the Burgundian wine-trade; it also manufactures cloth, cutlery, and leather, and has dye-works, flour-mills, and distilleries. Population in 1871, 10,415.

Beaune appears as a fortified place as early as the 7th century, and for some time was the capital of a separate duchy. United to Burgundy in 1227, it became the first seat of the Burgundian parliament, or *Jours Géméraux*, and was the residence of several of the dukes. On the death of Charles the Bold, it sided with his daughter, but was besieged and taken by Louis XI. in 1478. It suffered severely in the wars of the League, prospered in the reign of Henry IV., and was greatly injured by the revocation of the Edict of Nantes.

**BEAUSOBRE, ISAAO DE**, a learned Protestant writer, of French origin, was born at Niort in 1659, and after studying theology at the Protestant Academy of Saumur, was ordained at the age of twenty-two. He was forced into Holland to avoid the execution of a sentence condemning him to make the *amende honorable* for having broken the royal signet, which was put upon the door of a church of the reformers to prevent the public profession of their religion. He went to Berlin in 1694, and was made chaplain to the king of Prussia, and counsellor of the royal consistory. He died in 1738, aged seventy-nine, after having published several works, among which may be mentioned—(1.) *Défense de la Doctrine des Réformés, sur la Providence, sur la Prédétermination, sur la Grâce, et sur l'Eucharistie* (Magdeburg, 1694-8); (2.) A translation of the New Testament, with Notes, jointly with M. Lenfant (1718), much esteemed among Protestants; (3.) *Dissertation sur les Adamites de Bohême*, a curious work; (4.) *Histoire Critique de Manichéus et du Manichéisme*, 2 tom. 4to (Amst., 1734-9), a very learned and valuable work, discussing, as Gibbon observes, "many deep questions of Pagan and Christian theology, and forming a rich treasury of facts and opinions;" (5.) Several dissertations in the *Bibliothèque Britannique*. Beausobre had strong sense with profound erudition, and was one of the best writers of his time, and he preached as he wrote, with spirit and ability.

**BEAUVAIS**, a town of France, capital of an arrondissement in the department of Oise, situated in 49° 26' N. lat. and 2° 14' E. long., about 45 miles N. of Paris, in a valley at the junction of the Avelon and the Therain. The town is irregularly built, but possesses several edifices of historical and architectural interest. Chief among these is the cathedral of Saint Pierre, begun in 1225, continued at intervals till the 16th century by various ambitious projectors, and still incomplete. Its stained glass windows are both ancient and beautiful, though they are rivalled by those of Saint Étienne, another of the older churches in the town. Contiguous to the cathedral is a *basilica* of the 6th century, one of the oldest buildings of the kind in France. The episcopal palace, now used as a court-house, was built in the 16th century. Among the secular buildings are the town-house, dating from 1754, the college, which was formerly an Ursuline convent, a library with upwards of 15,000 volumes, a natural history museum, a theatre, a hospital, and barracks. The industry of Beauvais comprises, besides the weaving of tapestry, which dates from 1664, the manufacture of velvet and various kinds of cotton and woollen goods, leather, and earthenware. An extensive trade is carried on in grain and wine, and the products of the industrial establishments. Beauvais was known to the Romans as *Casaromagus*, and took its present name from the Gallie tribe of the *Bellovac*, whose capital it was. In the 9th century it was erected into a countship, which about 1013 passed to the bishops of Beauvais, who ultimately became peers of France. In 1346 the town had to defend itself against the English, who again besieged it in 1433. The siege which it suffered in 1472 at the hands of the duke of Burgundy was rendered famous by the heroism of the women, under the leadership of Jeanne Hachette, whose memory is still celebrated by a procession on the 14th of October (the feast of Ste Angadrème), in which the women take precedence of the men. Population in 1871, 15,542.

**BEAVER**, the English name of a genus of Mammals belonging to the order *Rodentia*, the two known species of which are among the largest members of that group. Both beavers, European and American, measure about 2 feet in length, exclusive of the tail, which is about 10 inches long, and are covered with the fur to which they owe their

chief commercial value. This consists of two kinds of hair,—the one close-set, silky, and of a grayish colour; the other much coarser and longer, and of a reddish brown. Beavers are essentially aquatic in their habits, never travelling by land unless driven to it by necessity. Their hind feet are webbed to the nails, and in swimming those only are used, the front legs remaining motionless by the side. They differ from all other rodents in possessing a broad horizontally flattened tail, somewhat oval in form and covered with scales, which they use as an aid to their progress through the water, and not as a trowel for plastering their mud houses as was formerly supposed. The front incisor teeth in each jaw have a sharp chisel-like edge, and are so formed as to preserve this through life. They consist of an outer layer of orange-coloured enamel, and a broad inner layer of a softer substance. As the creature gnaws, the softer material is worn away more rapidly than the enamel, which thus protrudes in a sharp ridge. There is a continuous growth at the roots of those teeth to repair the constant waste that goes on at the cutting edge, so that should one of the incisors be destroyed, the opposite tooth, meeting with no check to its enlargement, will grow to an enormous length; and beavers have been found in which this abnormal growth had proved fatal by preventing the other teeth from coming together. The enamel is exceedingly hard; and, until superseded by English files, those teeth, fixed in wooden handles, were used by the North American Indians in carving their weapons of bone. The question whether the American and European beavers are the same or different species, has given rise to some controversy; but it is now generally conceded, chiefly on anatomical grounds, that they are distinct, although in outward appearance they are almost identical.

The European Beaver (*Castor fiber*) was at one time an inhabitant of the British Isles, having been found, according to Pennant, in certain Welsh rivers as late as the 12th century, while fossil remains of it occur in various parts of the country. In Scandinavia beavers are now extinct,—the last known specimen having been killed in 1844. Isolated pairs are still occasionally met with on the banks of the Rhone, the Weser, and the Elbe; and a considerable number are to be found in one of the parks belonging to the emperor of Austria, on the banks of the Danube, where they are strictly preserved. They also occur, though sparingly, in Russia and Poland, in the streams of the Ural Mountains, and in those which flow into the Caspian Sea. They are said to live in burrows on the banks of rivers, like the common water rat, and to show little of the architectural instinct so conspicuous in the American species; this, however, is probably more owing to unfavourable external conditions than to want of the faculty, for there is at least one well-authenticated instance of a colony of beavers, on a small stream near Magdeburg, whose habitations and dam were exactly similar to those found in America.

The American Beaver (*Castor canadensis*) extends over that part of the American continent included between the Arctic circle and the tropic of Cancer; owing, however, to the gradual spread of population over part of this area, and still more to the enormous quantity of skins that, towards the end of last century and the beginning of the present, were exported to Europe, numbering about 200,000 annually, this species was in imminent danger of extirpation. More recently the employment of silk and of the fur of the South American Coypu in the manufacture of hats, so lessened the demand for beaver skins that the trapping of these animals became unprofitable; and being thus little sought after for many years, they have again become abundant in such of their old haunts as have not yet been occupied by man, so that the trade in beaver

skins has now nearly attained its former proportions. Solitary beavers, always males, and known as "old bachelors," or idlers, are found inhabiting burrows similar to those seen in Europe. These are generally found in the neighbourhood of new townships, and are supposed to be individuals that have remained after the colony had broken up, on that from some cause or another have been expelled from the society of their fellows. The American Beaver, however, is essentially social, inhabiting lakes, ponds, and rivers, as well as those narrow creeks which connect the lakes together. They generally, however, prefer flowing waters, probably on account of the advantages afforded by the current for transporting the materials of their dwellings. They also prefer deepish water, no doubt because it yields a better protection from the frost. When they build in small creeks or rivers, the waters of which are liable to dry or to be drained off, instinct leads them to the formation of dams. These differ in shape according to the nature of particular localities. Where the water has little motion the dam is almost straight; where the current is considerable it is curved, with its convexity towards the stream. The materials made use of are drift wood, green willows, birch, and poplars; also mud and stones intermixed in such a manner as must evidently contribute to the strength of the dam; but there is no particular method observed, except that the work is carried on with a regular sweep, and that all the parts are made of equal strength. "In places," says Hearne, "which have been long frequented by beavers undisturbed, their dams, by frequent repairing, become a solid bank, capable of resisting a great force both of ice and water; and as the willow, poplar, and birch generally take root and shoot up, they by degrees form a kind of regular planted hedge, which I have seen in some places so tall that birds have built their nests among the branches." Their houses are formed of the same materials as the dams, with little order or regularity of structure, and seldom contain more than four old, and six or eight young beavers. It not unfrequently happens that some of the larger houses have one or more partitions, but these are only posts of the main building left by the sagacity of the builders to support the roof, for the apartments, as some call them, have usually no communication with each other except by water. The beavers carry the mud and stones with their fore-paws, and the timber between their teeth. They always work in the night, and with great expedition. They cover their houses late every autumn with fresh mud, which freezing when the frost sets in, becomes almost as hard as stone, and thus neither wolves nor wolverines can disturb their well-earned repose.

The favourite food of the American Beaver is the plant called *Nephris luteum*, which bears a resemblance to a cabbage stalk, and grows at the bottom of lakes and rivers. They also gnaw the bark of birch, poplar, and willow trees. But during the bright summer days which clothe even the far northern regions with a luxuriant vegetation, a more varied herbage, with the addition of berries, is consumed. When the ice breaks up in spring they always leave their embankments, and rove about until a little before the fall of the leaf, when they return again to their old habitations, and lay in their winter stock of wood. They seldom begin to repair the houses till the frost sets in, and never finish the outer coating till the cold becomes pretty severe. When they erect a new habitation they fell the wood early in summer, but seldom begin building till towards the end of August.

The flesh of the American Beaver is usually eaten by the Indians and the Canadian voyageurs; and when roasted in the skin it is esteemed a delicacy. It is said to taste like pork. The *castoreum* of the beaver is a substance con-

tained in two pyriform sacs, situated near the organs of reproduction, of a bitter taste, and slightly foetid odour, at one time largely employed as a medicine for derangement of the nervous system, as hysteria, &c., but now little used. Fossil remains of both beavers are found in the Tertiary beds of the continents still inhabited by them, accompanied in each case by remains of an extinct species. The latter appear from their remains to have been much larger than those now existing.

BECCAFUMI, DOMENICO, was a distinguished painter of the school of Siena at the beginning of the 16th century. In the early days of the Tuscan republics Siena had been in artistic genius, and almost in political importance, the rival of Florence. But after the great plague in 1348 the city declined; and though her population always comprised an immense number of skilled artists and artificers, yet her school did not share in the general progress of Italy in the 15th century. About the year 1500, indeed, Siena had no native artists of the first importance; and her public and private commissions were often given to natives of other cities. But after the uncovering of the works of Raphael and Michel Angelo at Rome in 1508, all the schools of Italy were stirred with the desire of imitating them. Among those accomplished men who now, without the mind and inspiration of Raphael or Michel Angelo, mastered a great deal of their manner, and initiated the decadence of Italian art, several of the most accomplished arose in the school of Siena. (See articles PERUZZI and SODDOMA.) Among these was Domenico, born about 1488, of a peasant, one Giacomo di Pace, who worked on the estate of a well-to-do citizen named Lorenzo Beccafumi. Seeing some signs of a talent for drawing in his labourer's son, Lorenzo Beccafumi took the boy into his service and presently adopted him, causing him to learn painting from masters of the city. Known afterwards as Domenico Beccafumi, or by the nickname of Mecarino, signifying the littleness of his stature, the peasant's son soon gave proof of extraordinary industry and talent. In 1509 he went to Rome and steeped himself in the manner of the great men who had just done their first work in the Vatican. Returning to his native town, Beccafumi quickly gained employment and a reputation second only, if second, to Soddoma. He painted a vast number both of religious pieces for churches and of mythological decorations for private patrons, many of which are still to be seen where they were executed. But the work by which he will longest be remembered is that which he did for the celebrated pavement of the cathedral of Siena. For a hundred and fifty years the best artists of the state had been engaged laying down this pavement with vast designs in *cosmatesco* work,—white marble, that is, engraved with the outlines of the subject in black, and having borders inlaid with rich patterns in many colours. From the year 1517 to 1544 Beccafumi was engaged in continuing this pavement. He made very ingenious improvements in the technical processes employed, and laid down multitudinous scenes from the stories of Ahab and Elijah, of Melchisedec, of Abraham, and of Moses. These are not so interesting as the simpler work of the earlier schools, but are much more celebrated and more jealously guarded. Such was their fame that the agents of Charles I. of England, at the time when he was collecting for Whitehall, went to Siena expressly to try and purchase the original cartoons. But their owner would not part with them, and they are now the property of the cathedral works. The subjects have been engraved on wood, by the hand, as it seems, of Beccafumi himself, who at one time or another essayed almost every branch of fine art. He made a triumphal arch and an immense mechanical horse for the procession of Charles V. on his entry into Siena. In his later days, being a solitary liver and con-



tinnally at work, he is said to have accelerated his death by over-exertion upon the processes of bronze-casting. He died in 1551. (Vasari, ed. Lemonnier, x. 176-197; Ugurieri, *Pompe Scense*; G. Milanese, *Documenti*, &c.)

BECCARIA, CESAR BONIFAZIA, MARQUIS, a celebrated writer on the principles of jurisprudence and national economy, was born at Milan in the year 1735. He was educated in the Jesuit College at Parma, and showed at first a great fondness and aptitude for mathematics. The study of Montesquieu seems to have directed his attention towards economical questions; and his first publication (in 1763) was a tract on the derangement of the currency in the Milanese states, with a proposal for its remedy. Shortly after, in conjunction with his friends the Verria, he formed a literary society, and began to publish a small journal, in imitation of the *Spectator*, called *Il Caffè*. In 1764 Beccaria published his brief but justly celebrated treatise *Dei Delitti e delle Pene* ("On Crimes and Punishments"). The weighty reasonings of this work were expounded with all the additional force of a clear and animated style. It pointed out distinctly and temperately the grounds of the right of punishment, and from these principles deduced certain propositions as to the nature and amount of punishment which should be inflicted for any crime. The book had a surprising success. Within eighteen months it passed through six editions. It was translated into French by Morellet in 1766, and published with an anonymous commentary by Voltaire. An English translation appeared in 1768, and other countries followed the example. Many of the reforms in the penal codes of the principal European nations are traceable to Beccaria's treatise. In November 1768 the marquis was appointed to the chair of public law and economy, which had been founded expressly for him at the Palatine College of Milan. His lectures on political economy, which are based on strict utilitarian principles, are in marked accordance with the theories of the English school of economists. They are published in the collection of Italian writers on political economy (*Scrittori Classici Italiani*, vols. xi. and xii.) In 1771 Beccaria was made a member of the supreme economic council; and in 1791 he was appointed one of the board for the reform of the judicial code. In this post his labours were of very great value. He died in 1793. A notice of his life will be found prefixed to his lectures, referred to above.

BECCARIA, GIOVANNI BATTISTA, a distinguished electrician and practical astronomer, was born at Mondovì on the 2d of October 1716, and entered the religious order of the Pious Schools in 1732. He became professor of experimental physics, first at Palermo and then at Rome, and was appointed to a similar situation at Turin in 1748. He was afterwards made tutor to the young princes de Chablais and de Carignan, and continued to reside principally at Turin during the remainder of his life. In May 1755 he was elected a fellow of the Royal Society of London, to which he afterwards communicated several papers relating to his favourite pursuits. He died on the 27th of May 1781. Beccaria's name is associated with no great discovery in physical science; but he did much, both in the way of experiment and exposition, to spread abroad the researches of Franklin and others in the science of electricity. His own experiments, which were skilfully conducted, demonstrated a number of curious facts bearing on the relations of electricity to meteorological phenomena, to chemical action, and to some other points which have been since more thoroughly investigated. His principal work was the treatise *Dell'Elettricismo Artificiale e Naturale*, 1753, which was translated into English in 1776. He also contributed a number of papers to the *Philosophical Transactions*. In 1759 he was commissioned to measure an arc of the meridian in the neighbourhood of Turin.

The result, which he published in the *Gradus Taurinensis*, 1774, is not now considered perfectly correct.

BECCLES, a market-town and municipal borough, in the county of Suffolk, on the right bank of the River Waveney, 32 miles N.N.E. of Ipswich. It consists of several streets, is well built, and contains a fine old parish church, enlarged and repaired in 1859, several dissenting chapels, a free school, founded in the reign of James I., a free grammar school, a handsome town-hall, a custom-house, and a corn exchange. Malting is carried on to some extent; and by means of the river, which is navigable from Yarmouth, a considerable trade in coals and produce is carried on. The incorporation of the town dates from 1584. Population in 1871, 4844.

BECERRA, GASPÀR, a distinguished Spanish painter and sculptor, was born at Balma in 1520. He studied at Rome, it is said under Michel Angelo, and assisted Vasari in painting the hall of the Concelleria. He also contributed to the celebrated anatomical plates of Valverde. After his return to Spain he was extensively employed by Philip II., and decorated many of the rooms in the palace at Madrid with frescoes. He also painted altar pieces for several of the churches, most of which have been destroyed. His fame as a sculptor almost surpassed that as a painter. His best work was a magnificent figure of the Virgin, which was destroyed during the French war. Becerra died in 1570. The most competent judges assign to him the chief share in the establishment of the fine arts in Spain.

BÈCHE-DE-MER, or TREPANG, an important food luxury among the Chinese, Japanese, and other Eastern peoples, connected with the production of which a very considerable commerce exists in the Eastern Archipelago, the coasts of New Guinea, and generally on the coral reefs of the Pacific. It consists of several species of echinoderms, generally referred to the genus *Holothuria*; but very many varieties, widely distributed in Eastern seas, are prepared and sold in Chinese and Japanese markets. The creatures, which exist on coral reefs, have bodies from 6 to 15 inches long, shaped like a cucumber, hence a name they receive, — see cucumbers. The skin is sometimes covered with spicules or prickles, and sometimes quite smooth, and with or without "teats" or ambulacral feet disposed in rows. Five varieties are recognized in the commerce of the Pacific Islands, the finest of which is the "brown with teats," which are worth, at the place of their preparation, £30 per ton. The large black, which come next in value, bring £25 per ton; the small black £20, red bellied £15, and white £12. The finest of these sell for as much as £100 per ton in China, where they are used in the gelatinous soups, which form an important article of food in that empire. The preparation of the creatures when caught is very simple. They are boiled for about twenty minutes, after which they are split up and gutted, when they are ready for drying. The drying is conducted in large sheds on hurdles placed above a brick fire. The dried Bèches-dermer being very hygrometric, it is necessary that they be immediately packed up and shipped on the conclusion of the drying process; and unless they are thoroughly dry decomposition sets in rapidly and destroys the entire cargo.

BÈCHER, JOHANN JOACHIM, a celebrated chemist, born at Spire in 1635. His father, a Lutheran clergyman, died while he was very young, and the boy was compelled to support himself by teaching. He was a diligent student, and acquired a very extensive acquaintance with chemistry and allied sciences. In 1666, after having travelled through some parts of Europe, he was made professor of medicine at Mentz. He then removed to Munich, where he superintended the magnificent laboratory. His somewhat turbulent and unbending disposition obliged him to leave Bavaria, and he proceeded to Vienna, where he gained

the friendship of Zinzendorf. He was made member of the council of commerce, and proposed various commercial schemes to the Austrian Government. He soon quarrelled with Zinzendorf; and about 1678 we find him at Haarlem. After a short time he visited England and Scotland, inspecting their mines. He died in 1682, it is said at London. He wrote many works, the principal of which are—(1), *Physica Subterranea*, which was printed at Leipzig in 1703 and 1739, in 8vo, with a small treatise by E. Stahl, entitled *Specimen Becherianum*; (2), *Experimentum chymicum novum*, 8vo; (3), *Character pro Notitia Linguarum universalium*; (4), *Institutiones Chymicae, seu Manuductio ad Philosophiam Hermeticam*, 4to; (5), *Institutiones Chymicae, seu Edipus Chemicus*, 12mo; (6), *Experimentum novum ac curiosum de Miniarum arenaria perpetua, &c.* In some respects he anticipated Stahl, whose phlogistic theory is an extension of what he says. He was also the discoverer of boracic acid.

BECHWANA, or BETJUANA, the name of a nation extending over a large tract of the interior of South Africa, lying between 22° and 28° S. lat. and 22° and 29° E. long. There are remains as well as traditions indicating that they once occupied lands further to the south and north of their present boundaries. The country is bounded on the W. by what may be called the southern Sahara; on the E. by the Limpopo, and on the N. by the Matabele, a tribe which escaped the power of the Chaka, the bloody chief of the Zulus. The country, though hilly and undulating, abounds in grassy plains and considerable forests of acacia. Trees, however, are scarce, as the grass is generally burned off every year; and the young wood is thus not allowed time to grow. The natives also, in order to get fresh garden ground and obtain branches to raise their houses and make fences, are constantly destroying trees, and thus increasing the dryness and sterility of the country. It is evident, from the dry beds of what were once rivers and from remains of ancient forests, that, at an early period, the country must have been abundantly watered. From the many cattle folds and walls of defence scattered over the country, and ruins of ancient towns, it is also evident that at that period stone-dykes were very common.

The number of the Bechwana has been variously estimated, and according to some amounts to more than 200,000. Their language is copious, with but few slight dialectic differences, being entirely free of the Hottentot elements found in the Kaffre and Zulu. The power of the language which, like the Kaffre and Zulu, belongs to the Be-nta family, formerly unwritten, may be conceived when it is known that, besides elementary and educational works, the whole of the Bible has been translated into it and is now read by thousands.

The Bechwana are divided into numerous tribes, all independent of each other, and each governed by its own chiefs and councillors. The names of some of the principal tribes are Batlaepe, Barolong, Bangwaketse, Bakhatla, Bakuena, Bamangwato, and Batanana, the last living near the lake Ngami, first visited by Dr Livingstone. There are numerous minor divisions, with laws and customs very similar. With the exception of the Balala (the poor inhabiting the country), they are not nomadic, but live in towns of considerable size, containing from 5000 to 40,000. Doubtless, their former warlike habits had the tendency to induce them to congregate for security; for latterly they live, for the sake of agriculture and pasturage, in many formerly uninhabited places.

Though from time immemorial they had been engaged in constant strife with each other, and thus inured to warfare, they were no match for the warlike Kaffre and butchering Zulu and Matabele. Since the introduction of Christianity among the Bechwana, their clannish strifes have ceased;

and, being a people of industrious habits, and acute observers of whatever may increase their property and comfort, they go in great numbers to Cape Colony and other parts where they can obtain labour and wages, being prized as servants. This enables them to return enriched to their homes in a few years.

The government of the Bechwana may be said to be both monarchical and patriarchal, and of a comparatively mild character, the king, as chief, seldom exercising his individual authority independent of his councillors and subordinate chiefs. They have their public assemblies (parliaments), but only when circumstances, chiefly in reference to war, require. These are generally characterized by great freedom of speech, and sometimes the king's shortcomings are unsparingly dealt with. All is taken in good part, and there is no interruption of the speaker occupying the arena. The king generally closes the meeting with a long speech, referring to the subjects which each speaker had either supported or condemned, not forgetting to endeavour to clear his own character of any imputation. These public assemblies are now of very rare occurrence.

The Bechwana are well formed, dark brown or bronze, and the majority handsome and not assimilated to the negro type. In most the lower part of the face projects, but the skull exhibits no difference from the European type, and many have broad high foreheads, while there is nothing to be seen like the bent-out legs of the negro. The lips are generally thicker than in Europeans, and many have the nostrils wider. The hair is not wool, but simply hair curled and frizzled. They possess the knowledge of smelting iron and copper ore, and make hoes for husbandry, spears, battle-axes, tools, and a great variety of ornaments, chiefly of brass and other alloys. They prepare the skins of animals, and fabricate a variety of utensils. Agriculture and house-building (in which more skill and labour are required than with African huts in general, the houses being always round and admirably adapted to resist high and stormy winds) are the work of the women, while the men make the garments, hunt, and go to war when required.

The wealth of the Bechwana consists in their cattle, which they tend with the greatest care, manifesting a shrewd discrimination of localities and pasture suited to oxen, sheep, and goats. Living in a warm climate, they require few garments; but, though to a European they appear scantily dressed, both sexes are strictly decent, and are disgusted by the comparative nudity of the Kaffre and Matabele. Circumcision is practised, and for that purpose youths are selected from 10 to 18 years of age; these retire from the towns, the places in which they are being considered sacred till the season of seclusion, a month or more, is over, when they are allowed to return to their friends, and are looked on as men ready to go to war. The people have many ceremonies and superstitions, believing in the influence of witchcraft and charms, but no one of these has the most remote reference to religion. They have no knowledge whatever of idols, or anything intended to represent an invisible power, and consequently have nothing of a religious character. They do not possess a vestige of worship. With regard to a divine Being their ideas are vague in the extreme. The name *morimo*, from *mo*, a personal pronoun, and *rimo*, from *gorimo* (above), instead of being applied to something or some one heavenly—the Creator, Upholder, and Ruler of all—is applied to something that does harm, that inflicts death, or, according to some, a noxious creature that sometimes emerges from a hole to do mischief. So little do the natives care about it, that it never enters into their minds to have recourse to a charm, or anything of a fetich character, to ward off the influence it might be thought to possess. They never allow their thoughts to pierce beyond the moment of death, which is to them the finale of man's existence. Among some of the interior nations there is a belief in the names of dead kings of note, but not of the commonalty. Dr Moffat was once present when Moelekatese, the king of the Matabele, in a meeting in the midst of his nobles, in the dark, consulted the spirit of Machobane, his long deceased father. Whatever worship the Bechwana of old may have had, they have none now, not even of any of the animals—the fish, crocodile, monkey, &c.—from which some of the tribes are named. They have a superstitious dread of some things, which, in most if not in all cases, originates with the rainmaker. This is a notable character among all the interior tribes, and possesses supreme influence over the native mind. He has only to speak and it is done, whatever his orders may be. He pretends to give medicine to the clouds, and has recourse to all sorts of tricks and demands on his impatient dupes in order to gain time. Very frequently, when all fails, he falls a sacrifice to their wrath.

The country of the Bechwana south of the tropic of Capricorn is healthy, and admirably suited for pulmonary complaints. The temperature ranges from zero to 105°, and when it exceeds this, as it sometimes does, heavy thunderstorms follow, and not unfrequently hail falls of great size. The principal products are a variety of species of millet (*Holcus Sorghum*), kidney beans, pumpkins, water melons, sweet reed, &c.

The resources and capabilities of the country are small. Hitherto the exports have been principally ostrich feathers, ivory, and cattle; but the first two are become very scarce since the introduction of the horse and rife. The elephant is now found principally in the regions where the tsetse fly abounds, and where horses cannot live, while the ostrich betakes itself to the deserts. (R. M.)

BECK, or BEEK, DAVID, an eminent portrait painter, born in 1621, at Arnheim in Guelderland. He was trained by Vandyck, from whom he acquired the fine manner of pencilling and sweet style of colouring peculiar to that great master. He possessed likewise that freedom of hand and readiness, or rather rapidity of execution, for which Vandyck was so remarkable, insomuch that when King Charles I. observed the expeditious manner of Beck's painting, he exclaimed, "Faith! Beck, I believe you could paint riding post." He was appointed portrait-painter and chamberlain to Queen Christina of Sweden, and he executed portraits of most of the sovereigns of Europe to adorn her gallery. He lived in the highest favour with his royal mistress, and with difficulty obtained a short leave of absence from her court. He died soon after (1656) at the Hague, not without suspicion of having been poisoned.

BECKER, WILHELM ADOLF, a classical archaeologist of distinction, was born at Dresden in 1796. He was at first destined for a commercial life, but was, in 1812, sent to the celebrated school at Pforta, whence, in 1816, he passed to the University of Leipsic. Here he had the good fortune to study under the famous Hermann. After holding subordinate posts at Zerbst and Meissen, he was, in 1836, appointed extraordinary professor of classical archaeology at Leipsic; and six years later he was raised to the professorship of antiquities in the same university. He died at Meissen in September 1846. The works by which Becker is most widely known are the *Gallus, oder römische Scenen aus der Zeit des Augustus*, 1838, and the *Charities, oder Bilder altgriechischen Sitte*, 1840. The author shows not only a complete mastery of Greek and Roman antiquities, but a very happy faculty of imparting life to the dry bones of the science. Both works have been translated into English. Perhaps more useful for scholars is the great *Handbuch der röm. Alterthümer*, 5 vols. (1843-54), completed after Becker's death by Marquardt, and of which a second and enlarged edition is now in course of publication.

BECKET, or A BECKET, THOMAS. See A BECKET, vol. i. p. 31.

BECKFORD, WILLIAM, an English author, the son of Alderman Beckford, who was noted for his manly reply to George III. on the presentation of an address from the city of London, was born in 1761. At the age of nine he inherited a large fortune from his father; and in early life he travelled in Italy, Sicily, Spain, and Portugal, and resided some time near Cintra, where he had a princely residence. He afterwards returned to England, and after selling his old house of Fonthill began to build a magnificent residence there, on which he expended in about eighteen years the sum of £273,000. This, together with its splendid library and pictures, he sold to Mr Farquhar in 1822; but soon after one of the towers, 360 feet high, fell, destroying part of the villa in the ruins. Beckford, however, began the erection of another lofty structure on Lansdowne-hill, near Bath, where he continued to reside till his death in 1844. He was a powerful and original writer. His first work, *Biographical Memoirs of Extraordinary Painters*, which appeared in 1780, was a slight sarcastic *jeu d'esprit*. In 1784 he published in French the singular tale entitled *History of the Caliph Vathek*, which soon afterwards appeared in English, and has taken its place as one of the finest productions of richly luxuriant imagination. In 1834 his first Continental tour appeared under the title of *Letters from Italy, with Sketches of Spain and Portugal*, a work never, perhaps, surpassed for

striking description and refined sarcasm. His latest production, published in 1835, was entitled *Recollections of an Excursion to Alcobaza and Batallia in 1794*. All these works exhibit cultivated taste and a remarkable power of vivid description. He left two daughters, the eldest of whom was married to the 10th duke of Hamilton.

BECKMANN, JOHANN, the author of the *History of Inventions*, was born in 1739 at Hoya in Hanover, where his father was postmaster and receiver of taxes. His mother, who was left a widow before he was seven years of age, sent him to school at Stade; and in 1759 he repaired to the University of Göttingen with the intention of studying theology, which, however, he soon abandoned in favour of natural science. The death of his mother in 1762 having deprived him of his former means of support, he accepted, at the offer of Busching, the professorship of natural history in the Lutheran Academy, St Petersburg. This office he soon relinquished, and journeyed through Sweden, where he inspected the manner of working the mines, and formed the acquaintanceship of Linnæus at Upsala. In 1766 he was appointed professor at Göttingen. There he lectured on various arts and on political and domestic economy, and was in the habit of leading his students into the workshops that they might acquire a practical as well as a theoretical knowledge of different processes and handicrafts. While thus engaged he determined to trace the history and describe the present condition of each of the arts and sciences on which he was lecturing, being perhaps incited by the *Bibliotheca* of Haller. But even Beckmann's industry and ardour were unable to overtake the amount of study necessary for this task. He therefore confined his attention to several practical arts and trades; and to these labours we owe his *Notices on the History of Discoveries in the Common Arts of Life*,—a work in which he relates the origin, history, and recent condition of the various machines, utensils, &c., employed in trade and for domestic purposes. In 1772 Beckmann was elected a member of the Royal Society of Göttingen, and he contributed valuable scientific dissertations to its proceedings until 1783, when he withdrew from all further share in its work. After having been admitted into almost all the learned societies of Germany, and after having impressed on the minds of his numerous students a tendency to pursuits of practical utility, Beckmann died on the 3d of February 1811. His works display great natural sagacity, as well as profound and varied research. Besides the *History of Inventions* he wrote an interesting, but unfinished, *History of the Earliest Voyages made in Modern Times*, and produced editions of a work ascribed to Aristotle, of the *Wonderful Histories* of Antigonus Carystius, and of Marbodius's *Treatise on Stones*. These editions display a rare union of physical knowledge with philological learning. Beckmann was a man of extreme modesty; and his candour and sincerity, as well as his affability to those who studied under him, were acknowledged with one consent by his colleagues and his scholars.

BEDARRIEUX, a town of France, in the department of Hérault, situated on the River Orb, with a station on the branch railway from Béziers to Graissessac. It is a neat and well-built town, and carries on a variety of industries, among the most important of which are the weaving of cotton and woollen cloth and the manufacture of hats, paper, leather, and oil; while at Clairac in the neighbourhood there are glass-works and a copper-foundry. Most of the produce is exported to Africa and the Levant. Not far from the town there is a thermal establishment open all the year round. In the end of the 18th century the population was only 250; in 1872 it was 8985.

BEDDOES, THOMAS, a physician and scientific writer, was born at Shiffnall, in Shropshire, 13th April 1760.

From his infancy he was remarkable for his love of books. His father, who was a tanner, wished him to follow the same calling; but, mainly through his grandfather's recognition of his abilities, he was educated for one of the learned professions. After studying at Bridgorth grammar school and Plymhill, in Staffordshire, he entered, when about sixteen years of age, at Pembroke College, Oxford. There he proved himself an excellent linguist, while especially devoting himself to science. Having taken his bachelor's degree at twenty-one, he studied at London for the medical profession under Sheldon. In 1783 he became master of arts, and in 1784 he removed to Edinburgh, where he remained about three years. In 1784 he published a translation of Spallanzani's *Dissertations on Natural History*, and in 1785 produced a translation, with original notes, of Bergman's *Essays on Elective Attractions*. He took his degree of doctor of medicine at Oxford in 1786, and, after visiting Paris, where he became acquainted with Lavoisier, was appointed reader in chemistry at Oxford University. His lectures there attracted large and appreciative audiences; but his advocacy of the French Revolution exciting a clamour against him, he resigned his readership in 1792, and took up his abode with a friend at Ketley, in Shropshire. While resident there he published *Observations on the Nature of Demonstrative Evidence*, in which he maintains that geometry is founded on experiment, and the *History of Isaac Jenkins*, a story which powerfully exhibits the evils of drunkenness, and of which 40,000 copies are reported to have been sold. He endeavoured for many years subsequently to realize his project of a pneumatic institution, in which the efficacy of certain gases in curing diseases could be tested. While working for this object he was assisted by the father of Maria Edgeworth, Richard Lovell Edgeworth, one of whose daughters became his wife in 1794. He was ultimately enabled, by the liberality of Wedgwood, to establish the proposed institution (1798), and was fortunate in securing as its superintendent Mr (afterwards the famous Sir Humphrey) Davy, who had already given proofs of uncommon endowments, and many of whose discoveries were made in its laboratory. Among the first results of the pneumatic institution was the discovery of the chemical properties of nitrous oxide, in regard to which, as in many other cases, Beddoes showed himself over-sanguine and speculative. The original aim of the institution was gradually abandoned; it became an ordinary sick-hospital, and was relinquished by its projector in the year before his death, which occurred in 1808. Beddoes was a man of great powers and wide acquirements, which he directed to noble and philanthropic purposes. He strove to effect social good by popularizing medical knowledge, a work for which his vivid imagination and glowing eloquence eminently fitted him. In his manner of theorizing he considerably resembled his contemporary, the once celebrated Erasmus Darwin. Besides the writings mentioned above, he was the author of *Political Pamphlets* (1795-97), a popular *Essay on Consumption* (1779), which won the admiration of Kant, an *Essay on Fever* (1807), and *Hygeia, or Essays Moral and Medical* (1807). A life of Beddoes by Dr John E. Stock was published in 1810.

BEDDOES, THOMAS LOVELL, a modern English dramatist of peculiar and almost unique genius, was the son of the preceding, and was born at Clifton, 20th July 1803. He received his education at the Charter House, and subsequently at Pembroke College, Oxford, at both of which places he displayed a rugged independence of character, combined with eccentricity of demeanour and an aversion to the ordinary course of study. While still an undergraduate, he published his *Bride's Tragedy*, a piece less characterized by originality than his subsequent

performances, and altogether in the taste of the Elizabethan revival of the day initiated by the publication of Lamb's *Specimens*. The notice it obtained from Barry Cornwall and other representatives of this school, encouraged him to devote himself altogether to the cultivation of dramatic poetry; and he speedily produced a number of superb fragments, ranging down from the ambitious but unfinished sketches for tragedies to be entitled *Torriamond* and *The Second Brother*, to short descriptive passages of a few lines each, unsurpassed for originality of conception and condensed force. His genius, unfortunately, though highly poetical, was in no respect dramatic; he entirely lacked the power of constructing a plot and deducing character from action; and his endeavours to achieve a complete work proved abortive until 1829, when the strangely fascinating but fantastic and incoherent drama of *Death's Jest-Book*, or *The Fool's Tragedy*, was laboriously put together from a series of abortive attempts. By this time Beddoes had become a resident in Germany, and a zealous student of physiology, which, by affording another outlet for that intense curiosity respecting the mysteries of life and death which had hitherto been the mainspring of his poetical efforts, greatly contributed to repress the external manifestations of his genius. Dissatisfaction with his tragedy, which he never cared to publish during his lifetime, and the gradual disuse of his native language, conspired to reduce him to silence. He led for several years an unsettled life on the Continent, devoted to anatomical research, and actively participating in liberal and democratic movements in Germany and Switzerland, until his death in 1849 from the effects of an accident. His literary remains were published in 1861 by his friend Mr Kelsall, with a most interesting memoir, and copious selections from his graphic and striking correspondence, which is distinguished by all the characteristics of his verse. Beddoes is a poet for poets, and few other readers will enjoy him. He is "of imagination all compact;" his works scarcely contain a single passage of purely subjective feeling. He is, perhaps, the most concrete poet of his day; the most disposed to express sentiment by imagery and material symbolism. In this he resembles Keats, and may be termed a Gothic Keats, the Tenebrion counterpart of his more celebrated contemporary's Hellenism. The spirit of Gothic architecture seems to live in his verse, its grandeur and grotesqueness, its mystery and its gloom. His relation to the Elizabethan dramatists, moreover, is nearly the same as that of Keats to the Elizabethan pastoral poets; but the resemblance is one of innate temperament: he borrowed nothing, either from his Elizabethan precursors or the chief objects of his admiration among his contemporaries, Keats and Shelley. The want of constructive power which mars his dramas is even more prejudicial to his lyrics; but some few songs, where the right key-note has been struck from the first, rank among the most perfect in our language. The leading features of Beddoes's personal character were uncompromising independence, sterling integrity, and a thorough disdain for the opinion of the world. His life was entirely devoted to ideal aims, and his tastes were of the most simple and philosophic character. The asperity of his demeanour repelled strangers, but he was highly valued by the few whose intimacy he condescended to encourage.

BEDE, BƆDA, or BƆDA (commonly called The Venerable Bede), the father of English history, the most learned Englishman and most eminent writer of his age, was born about the year 673, in the neighbourhood of Monkwearmouth, in the N.E. of the county of Durham. The story of his life is told by himself at the conclusion of his most famous and most important work: "Thus much of the Ecclesiastical History of Britain, and more especially of the English

nation, as far as I could learn either from the writings of the ancients, or the tradition of our ancestors, or of my own knowledge, has, with the help of God, been digested by me, Bede, the servant of God, and priest of the monastery of the blessed apostles Peter and Paul, which is at Wearmouth and Jarrow; who being born in the territory of that same monastery, was given, at seven years of age, to be educated by the most reverend Abbat Benedict, and afterwards by Ceolfrid; and spending all the remaining time of my life in that monastery, I wholly applied myself to the study of Scripture; and, amidst the observance of regular discipline, and the daily care of singing in the church, I always took delight in learning, teaching, and writing. In the nineteenth year of my age I received deacon's orders; in the thirtieth, those of the priesthood. . . . From which time, till the fifty-ninth year of my age, I have made it my business, for the use of me and mine, to compile out of the works of the venerable Fathers, and to interpret and explain according to their meaning these following pieces" (a list of his writings follows). The two associated monasteries here mentioned were founded by Benedict Bisop on the lands between the Wear and the Tyne granted to him by King Egfrith. This learned and pious abbot was "the first person who introduced in England constructors of stone edifices, as well as makers of glass windows" (Will. of Malmesb.) But a greater honour attaches to him as having collected in his visits to Rome a large quantity of valuable books, which, deposited in the noble buildings he erected, had much to do with the extensive learning of his celebrated pupil. Bede, after three years at Wearmouth, removed with the Abbot Ceolfrid to the newly-founded Jarrow monastery, where he pursued to the close of his life those studies in every department of literature and science within his reach, the results of which we have in his numerous works.

Bede's industry was marvellous, alike in acquiring and in communicating his stores of knowledge. Besides the usual manual labours of the monastery, the duties of the priest, and his additional occupation as a teacher, he succeeded in writing upwards of forty distinct treatises, which together form what may be looked upon as an early encyclopaedia. Of these treatises twenty-five are on Biblical subjects, including commentaries on most of the books of the Old and New Testament and the Apocrypha. The remainder consist of lives of saints and martyrs; lives of the *Abbats of this Monastery*; his *Ecclesiastical History of our Island and Nation*; treatises on *The Nature of Things*, astronomy, chronology, arithmetic, medicine, philosophy, grammar, rhetoric, poetry, music; together with a *Book of Hymns*, and a *Book of Epigrams in heroic or elegiac verse*. While exhibiting little original thought or discovery, except in his historical works, and partaking of the credulity of his time, Bede excels in good judgment, and in thoroughly digesting and clearly arranging and expounding, in simple Latin, what he gathered in his wide range of reading in classical and theological authors. His Biblical works are principally made up of extracts from the Fathers, especially from St Augustine—his interpretations following the allegorical mode of the Middle Ages, as suggested by his own declaration: "He who knows how to interpret allegorically will see that the inner sense excels the simplicity of the letter, as apples do leaves." The scientific treatises are founded on the Bible, and the science of the ancients as contained in such writers as Pliny. Bede's historical works, on the other hand, and especially his great historical work, are remarkable for the patience indicated in the search after all trustworthy sources of information, for his careful statement of these various sources, for the sincerity and love of truth manifest throughout, and for the pleasant artlessness with which the story is told.

In the pursuit of knowledge Bede declined the dignity of abbot; for, he said, "the office demands household care, and household care brings with it distraction of mind, which hinders the prosecution of learning." But his reputation as a scholar, combined with "aptness to teach," made very famous the school of Jarrow, where it is recorded 600 monks, besides strangers from a distance, were at one time in attendance. The influence and authority of the modest teacher on Tyneside were acknowledged throughout the West of Europe, of which Northumbria became now for a period the literary centre. By the renown of its schools, its libraries, and its learning, chiefly represented by him, that kingdom had some recompense for the height of military glory it had reached in Bede's youth, and from which it had recently fallen at Nechtansmere. Pope Sergius, by a letter to Ceolfrid, sought Bede's presence and counsel at Rome, but it is almost certain the invitation was not acted upon. In another way, we can scarcely doubt, he efficiently helped the Papal court. Born about ten years after Rome gained her final victory over Iona at the Synod of Whitby, and four years after Theodore arrived at Canterbury to complete the ecclesiastical conquest, the character and writings of Bede must have strengthened the dominion of the hierarchy in the North of England. His positive efforts may have been confined to his three treatises on the time of celebrating Easter—one of the main questions in dispute. But indirectly, his historical works had the same tendency, exalting, as they do, the missionaries from Italy, while not ignoring the zealous labours of the followers of Columba. In himself, too, the people of Northumbria, the scene of contest, beheld one who brought honour to them as a fellow-countryman,—honour for which, at the same time, they were indebted to the now dominant church that had given him his training and opportunities of study. History, confirmed by the evidence of his writings, is loud in praise of Bede's humble piety as well as his learning. A long letter of his pupil Cuthbert has been preserved, giving a simple and touching account of his death, which probably took place in 735. Though "he suffered in his stomach, and drew his breath with pains and sighs," he was full of thanksgiving and rejoicing, singing psalms, conversing with his pupils, and dictating an Anglo-Saxon translation of the Gospel according to John. He was buried in the church at Jarrow, but his bones were stolen by a monk from Durham and placed beside those of St Cuthbert. There they continued until the middle of the 12th century, when they were enclosed in a splendid shrine by Bishop Pudsey. This shrine was demolished and the relics scattered in the reign of Henry VIII., there only remaining now at Durham the Latin inscription, which concludes with the well-known line—

"Hæc sunt in fossa Bedæ venerabilis ossa."

The origin of the title "Venerable" cannot be traced, but it appears as early as 836; and succeeding ages have gladly owned the justness of the appellation. For centuries his theological and educational works held a high position as authorities and even as text-books. The chief monument of his labours and erudition is his *Ecclesiastical History*, which gives us the most and the best of our knowledge of the history of England until 751, four years before his death.

Bede's works were published in 6 vols. fol., Paris, 1544, 1545, 1554, editions now rare; 8 vols. fol., Basel, 1563, and Cologne, 1612 and 1688; 12 vols. 8vo, with English translation, edited by Dr Giles, London, 1845-44. MSS. of the *History* are at Cambridge and Brit. Mus. Alfred translated it into Anglo-Saxon. Other translations are by Stapleton, 1565; John Stevens, 1723; and W. Hurst, 1814. Stevens's translation improved, edited by Giles, is published along with the *Anglo-Saxon Chronicle*, in Bohn's Antiquarian Library, 1847. All the historical works translated by Stevenson form part of vol. I. of *The Church Historians of England*, 1853-54.

**BEDELL, WILLIAM**, bishop of Kilmore and Ardagh, in Ireland, was born at Black Notley, in Essex, in 1570. He was educated at Cambridge, took orders, and, after leaving the university, settled for some years as clergyman in Bury St Edmunds. He was then appointed chaplain to Sir H. Wotton, English ambassador at Venice. In that town Bedell remained for eight years, acquiring great reputation as a scholar and theologian. He translated the *Book of Common Prayer* into Italian, and was on terms of closest friendship with Sarpi (Fra Paolo), the famous historian of the Council of Trent. In 1615, some time after his return to England, he was appointed to the rectory of Horningheath, in Suffolk, which he held for twelve years. He was then called to the provostship of Trinity College, Dublin, and relinquished that office after two years for the united bishoprics of Kilmore and Ardagh. As bishop he won the respect and love of his people by the uprightness and purity of his conduct. He set himself diligently to reform the abuses of his diocese, and personally undertook the duties generally discharged by the bishop's lay chancellor. In 1641, when the Protestants were being massacred in the Irish rebellion, Bedell's house was not only left untouched, but became the place of refuge for many fugitives. In the end, however, the rebels insisted upon the dismissal of all who had taken shelter in his house, and on the bishop's refusal he was seized and imprisoned with some others in the ruined castle of Loughborough. Here he was detained for several weeks, and when released, rapidly sank from the effects of exposure on his weakened constitution. He died on the 7th February 1642. His life was written by Burnet.

**BEDFORD**, the county town of Bedfordshire, a municipal and parliamentary borough and market-town, situated in a fertile vale on both sides of the River Ouse, which is here crossed by a handsome stone bridge of five arches. It is 50 miles N.W. of London, and has excellent railway accommodation as well as a navigable river. It is a station on the main line of the Midland Railway. The town consists chiefly of one long wide street, intersected by smaller ones at right angles. It is well built, and numerous villas and small streets have been erected on the west side since the opening of the Midland main line in 1868. It has five parish churches, four of which contain architectural features of interest. St Paul's has lately undergone considerable restoration, and the tower and spire have been rebuilt. St Peter's has been enlarged, but the ancient tower remains, in which are to be seen examples of Saxon work. St Mary's has a fine Norman tower, but the remainder of the church has at different times been restored. St John's has also been restored, but the original tower remains. St Outhbert's is a recent erection in the Norman style. A district church, dedicated to the Holy Trinity, was opened in 1841. There are also Independent, Methodist, Baptist, Roman Catholic, and other chapels. Bedford, in proportion to its size, has more public endowments than any other place in the kingdom, for which it is chiefly indebted to Sir W. Harper, Lord Mayor of London in 1561, who founded here a free school, and conveyed for its support, and for portioning poor maidens, a piece of ground in London, the surplus, if any, to be given to the poor. This ground has gradually risen in value so as now to produce nearly £14,000 annually. It supports grammar, modern, preparatory, and other schools. Formerly much of this large endowment was appropriated to eleemosynary purposes, which did not tend to the elevation of the character of the people; but since the enactment of a scheme of the Endowed Schools Commission in 1871, the whole amount is expended upon the schools, except a small proportion for the endowment of forty-five almshouses. The grammar school has eight exhibitions of £70 per annum each, at Oxford, Cambridge,

or Dublin. Among the public buildings are the schools, the shire-hall, the jail, the infirmary, the county library and assembly rooms, and the new corn exchange. The commercial prosperity of this town is greatly aided by the works of the Messrs Howard and others, for the manufacture of agricultural implements, &c. There are also manufactures of straw and lace in the neighbourhood. Bedford is governed by a mayor, six aldermen, and eighteen councillors; and it sends two members to parliament. It is exceptionally well provided with sanitary appliances, having a new complete system of sewerage and water-works; and the sewage is conveyed to a farm about a mile from the town and utilized at once for growing crops of grass, roots, and corn. Population in 1871, 16,850.

**BEDFORD LEVEL** the name given to a flat district on the eastern coast of England, comprising the greater part (amounting to 450,000 acres) of the marshy district called the *Fias*, the whole Isle of Ely in Cambridgeshire, and a portion of the north of that county, 30,000 acres of Suffolk, 63,000 acres of Norfolk, 57,000 of Huntingdon, about 8000 of Northamptonshire, and the south-eastern portion of Lincolnshire. The extent of the whole tract is 60 miles in length, from Milton in Cambridge to Toynton in Lincoln; its breadth is about 40 miles, from Peterborough in Northampton to Brandon in Suffolk. The boundary on three sides is irregular, giving it something of a horse-shoe shape, with the opening terminated by the sea on the north.

This district obtained its present name from the agreement of Francis earl of Bedford, the principal landholder, and thirteen other adventurers, with Charles I. in 1634, to drain the level, on condition of receiving 95,000 acres of the reclaimed land. The district has within historic times undergone remarkable changes. In the time of the Romans it was a dense forest, which, as a stronghold of the Britons, those invaders destroyed. It then became a swamp, through which the lazy waters of the Ouse, the Welland, the Neve, and Wisbeach, crept to the sea. In the 13th century the sea here, as in other parts of N.W. Europe, burst its boundaries, and the inundated land became a pestilential swamp. The first attempt to drain this morass seems to have been made in the year 1136, and embankments and ditches were formed at a great expense. These, however, were swept away during the ensuing winter by the flooding of the River Ouse. Another partial attempt at drainage was made by Bishop Moreton in the reign of Henry VII., but this also proved a failure. An Act was passed in the 44th year of Queen Elizabeth for effecting its reclamation; but the first effectual attempt at reclaiming it was not made until 1634, as already mentioned, and many embankments and canals were constructed at various intervals at an expense above one million sterling. Three years after the agreement of the earl of Bedford and his partners with the king, after an outlay of £100,000 on the part of the company, the contract was annulled, on the fraudulent plea that the works were insufficient; and an offer was made by King Charles to undertake its completion on condition of receiving 57,000 acres in addition to the amount originally agreed on. This unjust attempt was frustrated by the breaking out of the civil war; and no further attempt at drainage was made till 1649, when the Parliament reinstated the earl of Bedford's successor in his father's rights. After an additional outlay of £300,000, the adventurers received 48,000 acres of reclaimed land, according to the contract, which, however, fell far short of repaying the expense of the undertaking. In 1664 a royal charter was obtained to incorporate the company, which still exists, and carries on the concern under a governor, 6 bailiffs, 20 conservators, and a commonsalty, each of whom must possess 100 acres of land in the level, and has a voice in the election of officers. The conservators must each possess not less than 250 acres, the governor and bailiffs each 400 acres. The original adventurers had allotments of land according to their interest of the original 95,000 acres; but Charles II., on granting the charter, took care to secure to the crown a lot of 12,000 acres out of the 95,000, which, however, is held under the directors, whereas the allotments are not held in common, though subject to the laws of the corporation. The level was divided in 1697 into three parts, called the North, Middle, and South Levels—the second being separated from the others by the Neve and Old Bedford rivers.

Since then extensive works have at different times been carried on to complete the drainage of this district; but the most effectual are under the Acts of 1827 and 1829, for "improving the outfall of the Neve," "The Navigation of the Wisbeach," and "The Embanking of the Salt Marshes between the canal called Kinsley Cut and the sea." Vessels of 200 to 300 tons burden can now

come up to the town of Wisbeach at all tides, and those of from 500 to 600 tons at spring tides. The draining of the lower lands, which, like the Dutch *Folders*, are below low-water mark, was carried on by windmills, but these have now been almost superseded by steam-engines; in the North Level the drainage is effected by sluices. As the result of these extensive operations, the level now abounds in rich pasture and corn lands.

**BEDFORDSHIRE**, one of the south midland counties of England, surrounded by the counties of Buckingham, Northampton, Huntingdon, Cambridge, and Hertford. It is the fourth-smallest county, containing only 295,509 acres or 461 square miles. Its extreme length from north to south is about 47 miles, and its width 21 miles. The great Ouse, which flows through the county eastward, is navigable from Bedford to the sea at King's Lynn. The Midland and Great Northern Railways intersect the county, also the Bletchley and Cambridge branch of the London and North-Western. The surface of the county is for the most part level, but the northern half is undulating, with a subsoil generally of boulder-clay and Oxford-clay. A fine tract of land south of Bedford is bounded by a range of lower-green sand running east and west, presenting beautiful woodland scenery, parallel to which, along the Hertfordshire border, the Chiltern chalk range rises to 500 feet above the sea-level and 400 feet above the level of Bedford. The county is generally devoted to corn-growing, but the Ouse valley has a large breadth of rich pasturage, and all along the west side of the Great Northern railway is a sandy loam, on which onions, potatoes, and market produce are grown. Agricultural implement and other engineering works employ about 1000 hands at Bedford and Luton; while the female industry of the county is pillow-lace, and in the south straw-plait. The plait is made up, chiefly at Dunstable and Luton, into hats and bonnets, which are exported to all parts of the world. Luton is the most populous town in the county, slightly exceeding the county town of Bedford. The county rate assessment is £585,840, and the expenditure in 1873 was £11,802. The county belongs to the diocese of Ely, and coincides with the arch-deaconry of Bedford. It contains 9 hundreds and 124 parishes. It is in the Norfolk circuit, and assizes are held twice a year. A court of quarter-sessions sits at Bedford, and the petty sessional divisions are seven. Two members are returned to parliament for the county and two for the town of Bedford. The titles derived from the county are that of duke to the house of Russell, and of baron of Hethcote to the family of Lord St John, and the largest landowners are the duke of Bedford and Mr Whitbread of Southill. The most distinguished residence in the county is Woburn Abbey (duke of Bedford), near the town of that name. It was formerly a Cistercian abbey, granted at the Reformation by Henry VIII. to the family of Russell, the fourth duke of which house erected the present edifice. It is a very grand and capacious pile, situated in an extensive park, and is furnished with a large and valuable collection of paintings and statues. Luton Hoo is also an extensive mansion, which was reconstructed and improved for the third earl of Bute by the brothers Adam. A library, 146 feet in length, furnished with a valuable collection of books, and a large selection of paintings of some of the first masters, chiefly of the Italian school, are its distinguishing ornaments. Besides these there are other mansions which are highly deserving of notice, especially that of Mr Whitbread at Southill; Wrest Park, belonging to the Dowager Countess Cowper; Hawnes House, to the Rev. Lord John Thynne; Sutton, to Sir John M. Burgoyne; and Oakley House, to the marquis of Tavistock.

There are a general infirmary and fever hospital at Bedford; near Areysey is the Three Counties Lunatic Asylum (for Beds, Herts, and Hunts) provided for 685 patients; at Carlton is the juvenile county reformatory;

at Kempston the county school (300 boys), also the Military Brigade Depot. Connected with the county are the militia (18th Light Infantry), the duke of Manchester's cavalry volunteer corps, and the rifle volunteers.

The population of the county stood at the four last decennial enumerations as follows:—

Year.	Males.	Females.	Total.	Houses.
1841,	52,190	55,746	107,936	21,964
1851,	59,941	64,537	124,478	25,461
1861,	68,940	71,847	135,287	28,314
1871,	69,046	77,211	146,257	32,099

In the year 1871 the number of agricultural labourers was 15,962, of straw-plaiters 23,508 (90 per cent. being females), and of loom-makers 6051, all females. The towns and their populations in 1871 were as follows:—Luton, 17,317; Bedford, 16,850; Leighton-Buzzard, 4696; Dunstable, 4558; Biggleswade, 4244.

When the Romans landed in Britain Bedfordshire formed a portion of the district of the *Catticuchlani*, whose sovereign or chief, *Casibelennus* or *Cassivelaunus*, commanded the united forces which opposed Julius Cæsar. When, in the year 810, the Emperor Constantine ruled the whole island, and divided it into five provinces, Bedfordshire was included in the third division called *Flavia Casariensis*, and remained so till the final abandonment of Britain by the Romans. Under the Saxon heptarchy it formed part of the kingdom of Mercia, until with the rest of the island it was united to the kingdom of the West Saxons, which was divided by Alfred into counties, hundreds, and tythings, when this county first received its present name.

There are many remains of Roman, Saxon, and Norman antiquities. Traces of a Roman station are to be seen at Sandy near Potton, and at Maiden-Bower near Dunstable. Leighton-Buzzard, or Beaudesert, is supposed to have been a Roman camp. The ancient Icknield and Watling Streets passed through the county; and the remains of both may be definitely traced, as well as of some others constructed by the Romans.

**BEDNOR**, a town of Hindustan, in the territories of the Rájá of Mysore, situated in 13° 50' N. lat., and 75° 6' E. long. In 1645 the seat of government of the Rájás of Ikeri was transferred to this place; as the inhabitants of the former capital removed with the court, Bednor became a city of great importance, containing, it is said, 20,000 houses, besides huts. It was taken and plundered by Haidar Ali in 1763, who ordered it to be called Haidarnagar. It is still, however, known by its original name of Bednor. At that time it was estimated at 8 miles in circumference. In 1783 it surrendered to a British detachment under General Matthews, but being shortly after invested by Tipu Sultan, the garrison capitulated on condition of safe conduct to the coast. Tipu violated the stipulation, put General Matthews and the principal officers to death, and imprisoned the remainder of the force. At Tipu's death it contained 1500 houses, besides huts. The district of Bednor is situated on the summit of that range of hills, the Western Gháts, which overlooks the provinces of Canara and Malabar. In consequence of its elevation above the sea, and the steepness of the mountain chain, which rises like a wall to the height of 4000 or 5000 feet, the clouds of the south-west monsoon are here intercepted, and their contents precipitated on the table-land in deluges of rain, which continue for six months in the year, and are extremely favourable to vegetation. Its products are pepper, betel-nut, cardamums, and sandal wood. Cattle of small size are also bred. The imports are salt, rice, cocoa-nuts, oil, turmeric, and cotton cloths.

**BEDOUINS**, the portion of the Arab race that live in the desert in tents. See *ARABIA*, vol. ii. p. 246, *f*.

## B E E

**T**HE bee, from its singular instincts, its active industry, and the useful products resulting from its labours, has, from the remotest times, attracted general attention and interest. No nation upon earth has had so many historians as this remarkable class of insects. The patience and sagacity of the naturalist have had an ample field for exercise in the study of the structure, physiology, and domestic economy of bees; their preservation and increase have been objects of assiduous care to the agriculturist; and their reputed perfection of policy and government have long been the theme of admiration, and have supplied copious materials for argument and allusion to the poet and the moralist in every age. It is a subject that has been celebrated by the muse of Virgil, and illustrated by the philosophic genius of Aristotle. Cicero and Pliny record that Aristomachus devoted sixty years to the study of these insects; and Philicus is said to have retired into a remote wood, that he might pursue his observations on them without interruption. A very great number of authors have written express treatises on bees, periodical works have been published relating exclusively to their management and economy; and learned societies have been established for the sole purpose of conducting researches on this subject.

In so complicated a branch of natural history, correct observation and induction require laborious and long-continued efforts. But, on the subject of bees, the inquirer after truth had, besides, many obstacles to encounter from the very general diffusion of errors, which had been transmitted without due examination from one author to another. The history of the opinions of successive writers sufficiently proves how gradual and slow has been the growth of an accurate knowledge of these insects,—what is now known being the result of the persevering labours of ages. The accumulation of curious and interesting facts, indeed, which has accrued from the researches of Swammerdam, Maraldi, Reaumur, Schirach, Huber, Dzierzon, and Von Siebold, constitutes almost a new science. It will therefore be proper, in this place, to give a connected and systematic account of the natural history of the bee; and the principal features of internal conformation will be described along with the particular functions. Our descriptions will apply, more especially, to the common and best-known species, the *Apis mellifica*, which is the one particularly prized on account of the rich products it affords.

We shall begin with a brief account of the different sorts of bees inhabiting the hive, and of the respective offices of each; we shall then proceed to consider their comparative physiology, including the leading particulars relating to the functions of their various organs, sensitive powers, instincts, secretions, and diseases. We shall also explain the theory of parthenogenesis and the impregnation of queens, and shall follow the bees in their different labours, from the period when the swarm has settled in a new habitation,—detailing the complex structure of their combs, their curious processes of architecture, and the pains they bestow on rearing their progeny, and in sending forth new swarms; and, in the last place, we shall notice the best systems of modern bee-keeping, and give some account of hives and apian implements.

The leading feature in the natural history of bees, and one which distinguishes them from almost all other insects, is their singular distribution into three different kinds, constituting to all appearance so many different modifications of sex. The drone (fig. 1), which is characterized by a thicker body, a round head, a more flattened shape, and

more obtusely terminated abdomen, within which are contained the male organs of generation, is undoubtedly the male of the species. It is distinguished also by the absence of a sting, and by the humming noise that accompanies its flight. The queen-bee (fig. 2), which is unequivocally



FIG. 1.—Drone.

FIG. 2.—Queen-Bee.

FIG. 3.—Worker Bee.

recognized as the female, is larger than any of the others, has the abdomen of greater length, and is provided with a sting and two ovaria of considerable size. The worker bees (fig. 3) compose the third class, and are distinguished by the smallness of their size, their lengthened proboscis, the peculiar structure of their legs and thighs, which are adapted to the collection of certain materials obtained from vegetables, and by the apparent absence of every trace of generative organs,—we say *apparent*, because, as will be shown, rudiments of ovaria do exist, which, however, are not perceptible without a very minute and careful dissection. Till recently the worker bees were regarded as devoid of sex, and were accordingly termed *neuters*. It is their function to perform all the laborious offices for the community, to construct the interior of their habitation, to explore the country in search of nourishment and other materials, to collect and bring them to the hive, and apply them to different purposes, to attend upon the queen, and supply all her wants, to defend the hive from the attacks of depredators, and to carry on hostilities against the various enemies of the tribe. The life of the queen is chiefly engrossed with the duties of laying eggs. The drones producing neither wax nor honey, and depending on the rest for their subsistence, are idle spectators of the others' labours. They appear to be formed only for the momentary but important duty of impregnation, since they perish when this purpose is accomplished. There is commonly only one perfect queen existing at a time within each hive, and she usually appears to be treated by all the other bees with every mark of affection and of deference. The number of workers is very different in different hives; sometimes there are only a few thousands; at other times from twenty to forty, or even fifty thousand. The drones, even in the spring, seldom compose more than one-thirtieth or one-fortieth of the whole; and, at other seasons, there are none to be found in the hive when a fertile queen is present. In order to form some estimate of the number of bees which can occupy a certain space, Hunter counted what number of drowned bees could be contained in an alehouse pint, and found it to be 2160; so that if a swarm were to fill two quarts, their numbers would be nearly 9000. Reaumur, with the same view of ascertaining their numbers, employed the more accurate method of weighing them; he found that a collection, weighing one ounce, consisted of 336 bees, and, therefore, that 16 ounces, or one pound, would consist of 5376 bees.

Notwithstanding the difference in conformation, instincts, and offices between the queen-bee and the workers, it is now established on the most incontrovertible evidence that they both originally proceed from the same kind of egg or larva, which is capable of being converted, according to



circumstances, either into a worker or a queen. It has been proved that the former, although exhibiting no appearance of sexual organs on a superficial examination, are in reality females, and have the rudiments of these organs, which, however, not being developed, are incapable of exercising their proper functions, although it sometimes happens that they become sufficiently so to enable a worker to lay unfecundated eggs. It may be remarked that the idea of the worker bees being radically females had been suggested long ago by Dr. Warder in his *Monarchy of Bees*, in which he terms them "True Amazons;" but no attention had been paid to his opinion. The real merit of this great discovery, which affords a key to a multitude of hitherto inexplicable facts, unquestionably belongs to Schirach. When first announced to the world it was received with suspicion by the greater number of naturalists, and with complete incredulity by others. It was, indeed, at variance with the whole tenor of the observations of Swammerdam, Marsaldi, and Reaumur. Wilhelmi, the brother-in-law of Schirach, though an eye-witness of the experiments from which this theory had been deduced, for a long time refused to admit the doctrine, but at length became one of its most strenuous supporters. It is noticed in a vein of sarcastic ridicule by John Hunter in his otherwise excellent paper on bees in the *Philosophical Transactions*. Needham wrote a *Memoir* for the Imperial Academy of Brussels in 1777 for the express purpose of refuting it, and he then inveighs in strong language against those naturalists who had deigned to give it the least countenance. Bonnet, after exercising a laudable scepticism, and making a diligent inquiry, in which he displays a genuine spirit of philosophy, yielded a reluctant assent. But the truth of the doctrine has since been placed beyond the reach of controversy by a multiplied series of observations and experiments in different parts of Europe and America.

In considering the physiology of the bee, the first function that claims our notice is that of nutrition. The food of bees is principally of two kinds, namely, the fluid secretions of vegetables contained in the nectaries of the flowers, and the dust of the anthers, which has been termed by botanists the pollen, but which, when collected by the bees, has received a variety of appellations, such as farina, bee-bread, &c. Occasionally, however, we find bees feeding upon other saccharine substances besides honey, such as honey-dew, syrup, &c.

The organs by which they collect food are extremely complex, comprising instruments adapted to the reception of liquid aliment as well as those fitted for the division of solid materials. Reaumur has given a most elaborate description of these organs, and corrects some errors into which Swammerdam had fallen. For the purpose of taking up fluids, bees are provided, in common with all hymenopterous insects, with a long and flexible proboscis or trunk, which may be considered as a lengthened tongue, though, strictly speaking, it is formed by a prolongation of the under lip. It is not tubular, as Swammerdam had supposed, but solid throughout; and the minute depression at its extremity is not the aperture of any canal through which liquids can be absorbed. The trunk of the bee performs strictly the office of a tongue, and not that of a tube for suction; for when it takes up honey or any other fluid aliment, the under or the upper surfaces are more immediately applied to it, and rolled from side to side, and the bee thus licks up what adheres to it, while the extremity of the trunk is frequently not applied at all to the substance taken up. The trunk is supported on a pedicle, which admits of being bent back or propelled forwards, and thus can retract or stretch out the trunk to a considerable extent. Protection is given to it by a double sheath; the exter-

nal part consisting of two scales furnished by the expansion of one of the portions of the labial palpi, and the internal formed by the prolongation of the two external portions of the jaw. The whole member thus consists of five principal parts, on which account Fabricius termed it *lingua quinquefida*.

For the purpose of mechanically dividing solid materials, the mouth is furnished with two strong mandibles and four palpi; they are but little employed in eating, but are of great use in enabling the insect to seize and break down hard substances for other purposes. In the worker bee all these parts are of larger dimensions than in the other kinds. The teeth are two in number, and have the form of concave scales with sharp edges; they are fixed to the ends of the jaws, and play horizontally as in other insects. Reaumur describes and delineates a large aperture above the root of the proboscis, which is so surrounded with fleshy parts as not to be readily seen unless the proboscis be extended and bent downwards. This he considers as the mouth or orifice of the gullet; on the upper side of which, and of course opposite to the root of the proboscis, a small fleshy and pointed organ is seen, which he regards as the tongue, assisting in the deglutition of the food. Through this orifice, it is presumed, all the aliment, whether liquid or solid, passes; the former being conveyed to it by the trunk, which, by its contractile power, presses forward the fluids it has collected between itself and the inner sheath, and the latter being received directly after its comminution by the teeth, behind which it is situated. Latreille, however, whose authority is great on a point of this nature, thinks that Reaumur has deceived himself with regard to such an aperture, and disbelieves its existence. He conceives that the food simply passes on by the sides of the tongue, finding its way from thence into the oesophagus and so on to the stomach.

The bee has two stomachs. The first is a large transparent membranous bag, pointed in front and swelling out into two pouches behind. It performs an office in some respects analogous to that of the crop in birds; for it receives and retains for a time the fluid of the nectaries, which does not appear to differ in any respect from honey. Hunter observes that whatever time the contents of this reservoir may be retained he never found them altered so as to give the idea of digestion having taken place. The coats of this reservoir are muscular, by which means it is capable of throwing up the honey into the mouth, so that it is regurgitated into the honey cells or imparted to other bees. None of it ever passes out from the extremity of the trunk as Swammerdam had believed. For the purpose of digestion a second stomach is provided, which takes its origin from the middle of the two posterior lobes of the former, and is of a lengthened cylindrical shape. Its communication with the intestine is not direct, but takes place by a projecting or inverted pylorus, thickest at its most prominent part, with a very small opening in the centre, of a peculiar construction. This inward projecting part is easily seen through the coats of the reservoir, especially if full of honey. A similar kind of structure takes place at the communication of the first with the second stomach, and having the properties of a valve, must effectually prevent all regurgitation from the latter into the former.

The pollen, or fertilising dust of flowers, is collected by the bees for the purpose of feeding the young. It is stored in the cells until required, and then partly digested by the nurses with honey, and a kind of chyle formed of it. When natural pollen cannot be obtained the bees will eagerly take farina, either of rye, chestnuts, or pease, as a substitute, which appears to answer the same purpose. The bees, by means of the pencil of hair which grows on the tarsi, first collect a certain quantity of pollen, and then

knead it together into a ball, and place it in the space situated at the middle joint or tibia of the hinder leg, which has been termed the basket. This portion of the leg is smooth and concave, somewhat like the bowl of a spoon, with stout hairs of moderate length rising from its left edge and nearly straight. Other hairs on the right side are much longer and are curved, rising up with a high arch and crossing more than half the width of the hollow, making a large basket-like enclosure for a load of pollen. In order to gather large quantities at once, the bees are sometimes observed to roll their bodies on the flower, and then brushing off the pollen which adheres to them with the feet, form it into two masses, which they dispose of as before mentioned; and it is said that in moist weather, when the particles of pollen cannot be readily made to adhere, they return to their hive dusted all over with pollen, which they then brush off with their feet. The part in Nature's economy thus unconsciously performed by the bee in common with other insects is most important. By this means the pollen is carried from flower to flower, or from the stamens to the pistils, and plants are made fertile which without such aid would often remain barren.

It was long the received opinion that wax was but a modification of pollen, which required for this conversion only a slight pressure and a kind of kneading by the feet of the bee. But it has been completely proved, by the researches of Duchet, Hunter, and Huber, that wax is a secretion from the abdomen of the bee, and that it depends not at all on the pollen which the insect may consume (indeed, it is doubtful if it consumes any), but on the quantity of honey or other saccharine substance which it receives into its stomach. The first light thrown on this subject was in a letter of Wilhelmi to Bonnet in 1768, in which he says that wax, instead of being ejected by the mouth, exudes from the rings which enclose the posterior part of the body. Of this we may satisfy ourselves by drawing out the bee from the cell in which it is working with wax, by means of the point of a fine needle; and we may perceive, in proportion as the body is elongated, that the wax will make its appearance under the rings in the form of small scales. Duchet, in his *Culture des Abeilles*, gives a full statement of the principal circumstances attending the production of wax, which he very justly ascribes to the conversion of honey into this substance in the body of the bee. These facts appear to have been entirely overlooked till the subject was again brought forward by Hunter, in his paper in the *Philosophical Transactions* for 1792. Huber was engaged in prosecuting his inquiries on this subject at the same period with Hunter, and discovered, in 1793, the existence of regular receptacles or pouches, from the coats of which the wax is secreted, and within which it accumulates till its edges raise the scales, and become apparent externally. These plates of wax are withdrawn by the bee itself, or some of its fellow-labourers, and are applied in a manner hereafter to be described.

Huber has shown, by a series of well-conducted experiments, that, in a natural state, the quantity of wax secreted is in proportion to the consumption of honey, but that an equal or even greater quantity will be formed if the bee be fed on a solution of sugar in water. Warmth and rest promote this process of secretion; for the bees, after feeding plentifully on saccharine food, hang together in a cluster without moving, for several hours, at the end of which time large plates of wax are found under the abdominal rings. This happened when bees were confined and restricted from any other sort of nourishment, whilst those that were fed on pollen and fruits alone did not produce any wax. In the second volume of Huber's *Nouvelles Observations sur les Abeilles*, he describes minutely the anatomy of the pouches or receptacles for the wax, which

are parts peculiar to the working bees, being totally absent in the males and queens. The cavities are lined with a membrane, which presents a number of folds, forming an hexagonal net-work, not unlike the appearance in the second stomach of ruminant quadrupeds, and evidently destined to perform the office of secretion.

Among the secretions peculiar to the bee, the poison which is poured into the wounds made by the sting deserves to be noticed. It is said to owe its mischievous efficacy to certain pungent salts. If a bee is provoked to strike its sting against a plate of glass, a drop of poison will be discharged; and if this is placed under a microscope, the salts may be seen to concretise, as the liquor dries, into clear, oblong, pointed crystals. The sting consists of a finely-pointed tubular instrument, open along the whole length of its upper surface, this opening being closed by two slender horny barbs each having about ten serrations on its outer edge. These barbs are not projected in advance of the sting as usually described, neither are they within the sting, but complete its outer tubular surface, down the centre of which the poison is injected from a little bag at the root of the sting. The serrations prevent the worker bee from withdrawing its sting from an enemy; and, consequently, it is torn from the body, with a portion of the intestines, causing the death of the bee.

Respiration is effected by means totally different from those which are usual in the higher classes of the Animal Kingdom. As the blood, or fluid corresponding to the blood, cannot be presented to the air in any separate organ, the air must be conducted to the blood wherever such a fluid is met with. For this purpose tracheae, or air-tubes, having several external openings or spiracles, are made to ramify like arteries, and are distributed in an infinite number of branches to every part of the body. The condition of a hive of bees in which many thousand individuals, full of animation and activity, are crowded together in a confined space, having no communication with the external air but by means of a very small aperture in the lowest part, which aperture is frequently obstructed by a throng of bees passing in and out during sultry weather, would without some precautions be of all possible conditions the one least favourable to life. Bees cannot exist in an impure atmosphere any more than creatures of a larger growth. And on examining the air of a populous hive it is found scarcely to differ in purity from the surrounding atmosphere. The means by which this is effected observation has shown is by the rapid vibration of the bees' wings, a certain number being told off to imitate the action of flying, for which purpose they fasten themselves with their feet to the floor of the hive, so that the whole effect of that impulse which, were they at liberty, would carry them forwards with considerable velocity is exerted on the air, which is therefore driven backwards in a powerful current. Some bees occasionally perform these ventilating motions on the outside of the hive, near the entrance, but a still greater number are employed in this office within doors. Sometimes twenty are thus occupied at once, and each bee continues its motions for a certain time, occasionally for nearly half an hour, and is then relieved by another, which takes its place. So rapid a motion of the wings is thus produced that they cannot be seen except at the two extremities of the arc of vibration, which is at least one of 90°. This is the occasion of that humming sound which is constantly heard from the interior of the hive when the bees are in a state of activity. The immediate cause of these actions is probably some impression made on their organs by the presence of vitiated air, for a bee may be made to ventilate itself by placing near it substances which have to it an unpleasant odour.

The connection between an active respiration and a high

temperature is remarkably exemplified in bees, among which, in consequence of their collecting together in large numbers, the heat is not readily dissipated, and admits also of being easily ascertained by the thermometer. Hunter found it to vary from 73° to 84° Fahr.; and Huber observed it on some occasions to rise suddenly from about 32° to above 104°

The physiology of the external senses in a class of animals of a nature so remote from our own species must necessarily be very imperfectly understood by us. The infinite diversity of character presented by the different tribes of insects, as well as of other animals, naturally suggests the idea that external objects produce on their sentient organs impressions widely different from those which they communicate to ourselves. The notions we form of their senses must not only be liable to great inaccuracy, but may often be totally inadequate representations of the truth. A finer organisation and more subtle perceptions would alone suffice to extend the sphere of their ordinary senses to an inconceivable degree, as the telescope and the microscope have with us extended the powers of vision. But they possess in all probability other organs appropriated to unknown kinds of impressions, which must open to them avenues to knowledge of various kinds to which we must ever remain total strangers. Art has supplied us with many elaborate modes of bringing within our cognizance some of the properties of matter which nature has not immediately furnished us with the means of detecting. But who will compare our thermometers, spectroscopes, or hygrometers, however elaborately constructed, with those refined instruments with which the lower orders of animals, and particularly insects, are so liberally provided?

The antennæ, which are so universally met with in this class of animals, are doubtless organs of the greatest importance in conveying impressions from without. Their continual motion, the constant use which is made of them in examining objects, the total derangement in the instincts of those insects which have been deprived of them, point them out as exquisite organs of sense. To impressions of touch arising from the immediate contact of bodies they are highly sensitive, but their motions evidently show that they are affected by objects at some distance. They are, no doubt, alive to all the tremulous movement of the surrounding air, and probably communicate perceptions of some of its other qualities. Composed of a great number of articulations, they are exceedingly flexible, and can readily embrace the outline of any body that the bee wishes to examine, however small its diameter. Newport, in a paper published in the *Transactions of the Entomological Society*, says he is convinced from experiments that the antennæ are auditory organs; and that however varied may be their structure, they are appropriated to the perception and transmission of sound. The majority of modern physiologists and entomologists coincide in this view, and the weight of authority in favour of it is certainly very great, comprising as it does Sulzer, Scarpa, Schneider, Borkhausen, Bonndorf, Carus, Straus-Durckheim, Oken, Burmeister, Kirby and Spence, Lespès, and Hichs. Nevertheless, other eminent entomologists, as, for instance, Lyonet, Küster, Robineau-Desvoidy, Vogt, and Erichson, regard these organs as the seat of smell. The question may be considered as yet undetermined, and it is possible that they are the organs of some sense of which we know nothing, and which we consequently cannot describe. It is by these instruments that the bee is enabled to execute so many works in the interior of the hive, from which the light must be totally excluded. Aided by them it builds its combs, pours honey into its magazines, feeds the larvae, and ministers to every want which it appears to discover and judge of solely by the sense of touch. The antennæ appear also to be the

principal means employed for mutual communication of impressions. The different modes of contact constitute a kind of language which seems to be susceptible of a great variety of modifications, capable of supplying every sort of information for which they have occasion.

The sense residing in the antennæ appears to be on many occasions supplementary to that of vision, which in bees, as in other insects, is less perfect than in the larger animals. During the night, therefore, they are chiefly guided in their movements by the former of these senses. In full daylight, however, they appear to enjoy the sense of vision in great perfection. A bee alights unerringly on the flowers in search of nectar or pollen, and as truly at its own hive's entrance on its arrival there. When returning from the fields to its hive it seems to ascertain the proper direction by rising with a circular flight into the air; it then darts forward with unflinching precision, passing through the air in a straight line with extreme rapidity, and never failing to alight at the entrance of its own hive, though whether its course be determined by vision alone we are unable to say.

Their perceptions of heat and cold are extremely delicate. The influence of the sun's rays excites them to vigorous action. Great cold will reduce them to a state of torpor, and inferior degrees of cold are unpleasant to them; a temperature of 40° Fahr. will so numb a bee as to deprive it of the power of flight, and it will soon perish unless restored to a warmer atmosphere. When, however, bees are in the usual winter's cluster in the hive, they will bear a very great degree of cold without injury. In America hives often stand where the external temperature is as low as 20° below zero, and from the condensed vapour within the hive, the bees may be found in a solid lump of ice, and yet, with returning spring, they awake to life and activity. The degree of cold which bees can endure has not been ascertained, though it is no doubt considerable. They survive the winter in many cold parts of Russia, in hollow trees, without any attention being paid to them; and their hives are frequently made of the bark of trees, which does not afford a very complete protection from the effects of frost. Many bees which are thought to die of cold in winter die in reality of famine or damp. A rainy summer and cold autumn often prevent their laying in a sufficient store of provisions; and the hives should, therefore, be carefully examined in the after-part of the season, and the amount of food ascertained. Mr White judiciously observes, that bees which stand on the north side of a building whose height intercepts the sun's beams all the winter will waste less of their provisions than others which stand in the sun; for, coming forth seldom, they eat little, and yet are as forward in the spring to work and swarm as those which had twice as much honey left with them the preceding autumn. They show by their conduct that they are sensible of changes in the state of the weather for some time before we can perceive such alterations. Sometimes when working with great assiduity they will suddenly desist from their labours, none will stir out of the hive, while all the workers that are abroad hurry home in crowds, and press forward so as to obstruct the entrance of the hive. Often, when they are thus warned of the approach of bad weather, we can distinguish no alteration in the state of the atmosphere. Gathering clouds sometimes produce this effect on them; but perhaps they possess some species of hygrometrical sense unconnected with any impression of vision. Huber supposes that it is the rapid diminution of light that alarms them, for if the sky be uniformly overcast they proceed on their excursions, and even the first drops of a shower do not make them return with any great precipitancy.

Their taste is, perhaps, the most imperfect of their senses. They use scarcely any discrimination in the collection of honey from different flowers. They are not repelled by the scent or flavour of such as are extremely offensive to our organs, and scruple not to derive supplies from such as are highly poisonous. In some districts in America it is well known that honey acquires in this way very deleterious properties. The qualities of honey are observed to vary much according to the particular situation from which it is obtained. In their selection of flowers they are guided by the quantity of honey they expect to meet with, and in no respect by its quality. That gathered from ivy blossoms in England is sometimes so bitter and nauseous as to be useless for our eating, although the bees consume it readily. But their smell must be sufficiently acute to enable them to discover honey at great distances, and in concealed situations direct experiment has indeed proved this to be the case. Huber found that they proceeded immediately towards boxes which contained honey concealed from view; and such, in fact, is the situation of the fluid of the nectaries in flowers. Some odours, and especially all kinds of smoke, are highly obnoxious to them; and this is also the case with ammonia and other volatile chemical agents, upon receiving the impression of which they immediately set about ventilating themselves in the usual manner. The odour of the poison of their sting produces similar effects, exciting them to immediate rage and hostility. It has been observed that bees recognize the presence of a stranger in their hive by the smell; and in joining two stocks into one, if the bees are united without precautions, a battle will probably ensue. To obviate this bee-keepers are in the practice of strongly scenting both families by means of peppermint, tobacco smoke, or other strong-smelling agent; this overpowering the bees' natural scent, they are unable to distinguish their own party from the intruders, and peace is insured. The sense of vision does not appear to aid them, for where Ligurians are added to common black bees the effect is the same, although in colour the two varieties are very different. In the introduction of an alien queen to a stock it is also usual to imprison the new sovereign within the hive which she is to rule until she has acquired the peculiar scent of her future subjects, who will then make no objections to her, while had she been at once set at liberty she would probably have met her death.

Although it is clear that insects possess the power of smell, yet the particular organ of this sense has never been accurately ascertained, and the opinions of naturalists have been much divided on the subject. These opinions have been supported more by arguments drawn from the analogy of what happens in other classes of animals than by direct experiment on insects themselves. We know that in all animals respiring by means of lungs, the organs of smell are placed at the entrance of the air-passages; and it has often been concluded that in like manner the stigmata, or the orifices of the air-tubes, are the seat of this sense in insects. Huber's opinion was that in the bee this sense resides in the mouth itself, or in its immediate vicinity. Here, indeed, would be its proper station if this faculty be intended, as we may reasonably suppose it to be, to apprise the individual of the qualities of the food prior to its being eaten. When the mouth of a bee was plugged up with paste, which was allowed to dry before the insect was set at liberty, it remained quite insensible to the same odours to which it had before manifested the strongest repugnance.

It is generally supposed that bees possess the sense of hearing. The common practice of making a loud noise by drums and kettles in order to attract a swarm is founded on this supposition. But the evidence is by no means

conclusive, for we find that they are not disturbed by a loud clap of thunder, or by the report of a gun, or by any other noise that may happen to arise round them. Sir John Lubbock, who has made a great many observations in this direction, says that he could never find them take notice of any sound he made even when it was close to them. He tried them with a violin, dog whistle, shrill pipe, and set of tuning forks, also by shouting, &c., close to their heads, but in spite of his utmost efforts the bees took no notice, not even by a twitch of the antennæ showing they heard. It is, however, certain that they are capable of emitting a variety of sounds which appear expressive of anger, fear, satisfaction, and other passions; and it would seem that they are even capable of communicating certain emotions to one another in this manner. Huber observed that the young queens not yet liberated from their cocoons sent forth a peculiar piping sound, and this is answered by the old queen, who apparently must hear the note of her aspiring rival.

A certain cry or humming noise from the queen will strike with sudden consternation all the bees in the hive, and they remain for a considerable time motionless and stupefied. Hunter has noticed a number of modulations of sound emitted by bees under different circumstances, and has instituted an inquiry concerning the means employed by them in producing these sounds; for an account of this see his paper in the *Philosophical Transactions*.

If the function of sensation in insects be involved in doubt and obscurity, the knowledge of those more interior faculties, which are the springs of voluntary action, is hid in still deeper mystery. Buffon refuses to allow bees any portion of intelligence, and contends that the actions we behold, however admirably they are directed to certain ends, are in fact merely the results of their peculiar mechanism. Other philosophers, such as Reaumur and Brougham (*Works*, vol. vi.), have gone into the opposite extreme, and have considered them as endued with extraordinary wisdom and foresight, as animated by a disinterested patriotism, and as uniting a variety of moral and intellectual qualities of a higher order. The truth, no doubt, lies between these overstrained opinions; but it is nevertheless extremely difficult to decide in what degree these respective principles operate in the production of the effects we witness. The term *instinct* should properly be regarded, not as denoting a particular and definite principle of action, whose operation we can anticipate in any new or untried combination of circumstances, but as expressive of our inability to refer the phenomena we contemplate to any previously known principle. Thus the actions which an animal performs in obedience to the calls of appetite are not properly said to be instinctive; nor can the term be applied to actions which are the consequence of acquired knowledge, and of which the object is with certainty foreseen by the agent. But when an animal acts apparently under a blind impulse, and produces effects useful to itself or to the species, which effects it could not have previously contemplated as resulting from those actions, it is then customary to say that it is under the guidance of instinct, that is, of some unknown principle of action. It will be proper, therefore, to keep this distinction in view in judging of the voluntary actions of the lower animals.

In no department of natural history is it more necessary to be aware of the proper import of the term *instinct*, than in studying the phenomena presented by the bee; for nowhere is it more difficult to discriminate between the regular operation of implanted motives and the result of acquired knowledge and habits. The most striking feature of their history, and the one which apparently lays the foundation for those extraordinary qualities which raise them above

the level of other insects, is the disposition to social union. It may in general, indeed, be remarked, that animals which associate together so as to form large communities, display a higher degree of sagacity than those which lead a solitary life. This is especially observable among insects. The spider and *Formica leonis* may exhibit particular talents, or practise particular stratagems in the pursuit and capture of their prey; but their history is limited to a single generation, and embraces none of those interesting relations which exist between individuals composing the gregarious tribes, such as the ant, the wasp, and the bee. Among these we trace a community of wants and desires, and a mutual intelligence and sympathy, which lead to the constant interchange of good offices, and which, by introducing a systematic division of labour, amidst a unity of design, leads to the execution of public works on a scale of astonishing magnitude. The attachment of bees to their hive, which they defend with a courage and self-devotion truly admirable, their jealousy of intruders, their ready co-operation in all the labours required for the welfare of the community, their tender care of their young, the affection and homage which they bestow on their queen, imply qualities such as we could hardly persuade ourselves could animate a mere insect, on which we are in the habit of proudly looking down as placed in one of the lowest orders of created beings.

We shall content ourselves at present with these general observations, as the instances which serve to illustrate their moral and intellectual character belong properly to the history of the different processes they follow in the construction of their combs, the hatching and rearing of their progeny, and the mode of conducting their migrations. To these subjects, therefore, we shall now proceed; and in order to present the most connected and complete account of their economy, we shall begin the history from the period when a new swarm has just occupied a hive, and when all the arrangements for their habitation, and the construction of the cells in which their eggs and provisions are to be deposited, are yet to be effected.

The first care of the worker bees, on their settlement in their new abode, is to clean it out thoroughly. While one set of bees is thus employed, another is distributed about the country in order to procure the proper materials for blocking up the small holes and chinks of the hive, and for laying a firm foundation for the edifice which is to be constructed within it. The substance which is principally employed in this preliminary stage is *propolis*, a species of glutinous resin, of an agreeable aromatic odour, and reddish-brown colour, in process of time becoming darker, and acquiring a firmer consistence. According to the analysis of Vauquelin (*Mém. Soc. Agricult. Departem. Seine*), it is composed chiefly of resin, with a small proportion of wax, and of acid and aromatic principles. It is soluble in alcohol, ether, and oils, both fixed and volatile, and tinges the solvent of a beautiful red colour. Cadet has since ascertained in it the presence of benzoic and gallic acids. Reaumur had not been able to discover from what plants the bees collect this substance. Riem asserts that it is chiefly from pines and other trees of the fir kind. The observations of Huber have assisted in the solution of this question. On placing branches of the wild poplar tree before the hive, he found that the bees eagerly seized upon the varnish which exudes from the buds; and examining the chemical properties of this varnish, he identified it with the propolis with which the inside of the hive is lined.

The propolis adheres so strongly to the legs and feet of the bee which has collected it, that it cannot be detached without the assistance of its fellow-labourers. For this purpose the bee that is loaded presents its legs to the workers in the hive, which carry off with their jaws this

adhesive substance, and immediately apply it, while yet ductile, all round the interior of the hive, and particularly over all the projecting parts; hence its name, of Greek derivation, signifying *before the city*. In like manner all the foreign bodies that are introduced into the common habitation and are too heavy for removal are covered over with this resinous substance. If a snail, for instance, should happen to introduce itself into the hive, after despatching it with their stings, they encrust it over with propolis.

The next object of their labours is the construction of the combs, the future receptacles for the eggs with which the queen is pregnant and which are row to be laid. The material employed is wax; and the bees, for the purpose of secreting this, are actively employed in collecting honey. When they have filled their crops with honey they hang together in a thick cluster from the top of the hive, and thus remain in a state of inactivity for a considerable period, during which time the secretion of wax is proceeding. It may be seen collected in laminae under the abdominal scales, whence it is removed by the hind legs of the bee, transferred to the fore legs, and from thence taken up by the jaws. In this operation they are often assisted by their companions, who even sometimes directly seize upon the wax from under the abdomen of those who are before them. When a sufficient quantity of material has thus been collected together, the process of building is commenced; but in order to understand the subsequent operations it is necessary to have a correct idea of the form of the cells which compose the combs. We shall, therefore, proceed to give some account of the structure when it has attained its perfect state.

The combs of a bee-hive are formed in parallel vertical strata, each of which is about an inch in thickness, the distance between the surfaces of adjoining strata being about half an inch, a space which allows for the passage of the bees over both surfaces. The combs generally extend the whole breadth of the hive, and nearly the whole length from the top to the bottom. They consist of thin partitions which enclose hexagonal cells, opening on both surfaces of the comb and closed by a partition which is common to those on both sides, and occupies the middle distance between the two surfaces. This partition is not, however, a plane, but is composed of a collection of rhombs. Three and sometimes four of these rhombs incline to one another at a certain angle from the bottom of each cell, which thus has the shape of a flattened pyramid, of which the base is towards the mouth of the cell. The geometric form of each individual cell is therefore a hexagonal prism, terminated by a trihedral pyramid, the three sides of which are rhombs which meet at the apex by their obtuse angles, and, forming oblique angles with the sides of the prism, truncate a portion of these, and convert them from rectangles, which they would be in a regular prism, into trapeziums. Of the two angles of these trapeziums adjoining the base of the pyramid one must be acute and the other obtuse, the acute angle of one trapezium being next to the acute angle of the adjoining trapezium, and the obtuse angle being in like manner next to another obtuse angle of the preceding trapezium; so that in going round the base we meet with pairs of acute and of obtuse angles alternately succeeding each other. The two adjoining acute angles of the trapezium are adjoining to two of the terminal rhombs which here present their acute angles, so that at these points a solid angle of four planes is formed, all the angles being acute. Each pair of obtuse angles of the trapezia, on the other hand, are adjacent to the obtuse angle of one of the rhombs only, thus composing a solid angle of three planes of which the angles are all obtuse; and these two kinds of solid angles succeed one another,

alternately all round the base of the pyramid, there being three of each kind and six in all. The axis of each cell coincides not with the axis of the cell on the opposite surface, but with one of its angles; so that each of the three obtuse angles at the base of the terminal pyramid corresponds to the central parts of three of the cells on the opposite side, and each of the sides of the pyramid which closes a cell on one side contributes in part to the enclosing of three of the cells on the opposite side. We may easily satisfy ourselves that such is the case by piercing the centres of each of the three planes which close the bottom of a cell with a pin, when on turning the comb the three pins will be found to have passed into three different cells on the opposite side.

A structure of this kind is obviously the one of all others calculated to afford the greatest space for each cell with the same quantity of materials. It is easy to perceive, in the first place, that in a plane surface, when a number of small spaces are to be divided by partitions, the hexagonal form is the one which comprehends the largest space compatible with the extent of the lines which enclose them; for the equilateral triangle, the square, and the regular hexagon, are the only regular forms that admit of being joined together in the same plane without leaving interstices; and the proportion of the area to the periphery in every polygon increases as the figure consists of a greater number of sides, and is, therefore, greater in the hexagon than in either of the other two. The truth of this proposition was perceived by Pappus; and even its application to the subject of the honeycomb was made by that ancient geometrician. But the determination of the form and inclination that should be given to the partitions that close the bottom of the cells, and which may, of course, belong equally to those on both sides of the comb, is a problem much more complicated and difficult of solution. It has exercised the skill of several modern mathematicians of great eminence. Reaumur proposed to König, pupil of the celebrated Bernoulli, and an expert analyst, the solution of the problem:—To find the construction of a hexagonal prism terminated by a pyramid composed of three equal and similar rhombs (and the whole of given capacity), such that the solid may be made with the least possible quantity of materials;—which in other words was asking him to determine the angles of the rhombs that should cut the hexagonal prism so as to form with it the figure of the least possible surface, since the hexagon being given, this decided both their dimensions and their intersections with the sides of the cell. Maraldi had previously measured the angles of the rhombus and found them to be  $109^{\circ} 28'$  and  $70^{\circ} 32'$  respectively; but König was not aware of this until after he had solved the problem, and assigned  $109^{\circ} 26'$  and  $70^{\circ} 34'$  as the angles, when he had sent him the *Memoirs of the Academy of Sciences* for 1712, containing Maraldi's paper; and König was equally surprised and pleased to find how nearly the actual measurement agreed with the result of his investigation. The measurement of Maraldi is correct, and the bees have, with rigorous accuracy, solved the problem, for the error turns out to be in König's solution. The construction of cells, then, is demonstrated to be such that no other that could be conceived would take so little material and labour to afford the same room.

Boscovich, who has also given a solution of the same problem, supposes that the equality of inclination of the planes gives greater facility to the construction of the comb, and might, therefore, be a motive of preference, independently of the greater economy of wax. Maclaurin has offered a solution of this problem, and has demonstrated by simple geometry, that the most advantageous form is that which results from the supposed equality of the three plane angles forming the solid angles at the base. He

estimates the saving of wax by partitions so constructed, above what would be required for a flat partition, at one-fourth of the wax which would be wanted to complete the truncated sides of the cells, so as to form them into rectangles. L'Huilier, in the *Memoirs of the Berlin Academy*, has given a demonstration which is remarkable for its simplicity, and for its involving none but elementary propositions; he values the economy of wax at  $\frac{1}{4}$  of the whole wax employed. Le Sage, as appears from the life of that philosopher by Professor Prevost, has shown that this celebrated problem reduces itself to the finding of the angle at which two planes with a given inclination (such as  $120^{\circ}$ ) can be cut by a third plane, so as to make all the angles resulting from the section equal to one another.

But a more essential advantage than even the economy of wax results from this structure, namely, that the whole fabric has much greater strength than if it were composed of planes at right angles to one another; and when we consider the weight they have to support when stored with honey, pollen, and the young brood, besides that of the bees themselves, it is evident that strength is a material requisite in the work.

It has often been a subject of wonder how such diminutive insects could have adopted and adhered to so regular a plan of architecture, and what principles can actuate so great a multitude to co-operate, by the most effectual and systematic mode, in its completion. Buffon has endeavoured to explain the hexagonal form by the uniform pressure of a great number of bees all working at the same time, exerted equally in all directions in a limited space; and illustrates his theory by supposing a number of similar cylinders compressed together, and taking the form of hexagonal prisms by the uniform expansion of each. The analogy of the forms produced by the law of crystallization,—of the figures assumed by various organs in the animal and vegetable world, such as the skin of the bat, and the inner coat of the second stomach of ruminant quadrupeds,—is also adduced by this captivating but superficial writer in support of his argument. But however plausible this theory may at first sight appear, it will not stand the test of a serious examination. The explanation he has attempted applies no further than to the inclination of the sides of the cells; but he did not take into account, perhaps from not having studied the subject mathematically, the inclinations and forms of the planes which close each cell, and so curiously conspire on both sides to serve a similar office, while they at the same time accurately fulfil a refined geometrical condition. But it is sufficient confutation of the whole theory to show, that it is directly at variance with the actual process employed by the insects in the construction of their combs.

It might be supposed that bees had been provided by nature with instruments for building of a form somewhat analogous to the angles of the cells; but in no part, either of the teeth, antennae, or feet, can any such correspondence be traced. Their shape in no respect answers to that of the rhombs, which are constructed by their means, any more than the chisel of the sculptor resembles the statue which it has carved. The shape of the head is indeed triangular, but its three angles are acute, and are different from that of the planes of the cells. The form of the plates of wax, as they are moulded in the pouches in which this substance is secreted, is an irregular pentagon, in no respect affording a model for any of the parts which compose the honeycomb. Hunter, observing that the thickness of the partition was nearly equal to that of the scale of wax, thought that the bees apply these scales immediately to the formation of the partition, by merely cementing them together. Reaumur, notwithstanding the use of glass hives, had not been able to discover the mystery of their process

of architecture, but inferred, from what he saw, that the wax was rejected from the stomach in the form of a white frothy liquor. No naturalist, indeed, prior to Huber, had been able to follow these insects in their labours, on account of their crowding together in a thick mass while they are building; but the expedients resorted to by that philosopher have unfolded the whole process, which he has given with great detail in the second volume of his *Observations sur les Abeilles*. Huber witnessed the whole of their actions, and saw that each bee drew out, with its hind feet, one of the plates of wax from under the scale where it was lodged, and carrying it to the mouth in a vertical position, turned it round, so that every part of its edge was made to pass in succession under the cutting edge of the jaws; it was thus soon divided into very small fragments, while at the same time a frothy liquor was poured upon it from the tongue, so as to form it into a perfectly plastic mass. This liquor gave the wax a whiteness and opacity which it did not possess originally, and rendered it at the same time tenacious and ductile. A quantity of wax thus prepared for use is accumulated, and applied to further the work in the manner we are presently to describe.

But, in considering the process by which the comb is formed, a circumstance should be pointed out, which seems not to have been particularly noticed by any author except Huber, and yet it is one of essential importance in studying this process of architecture, namely, that the cells in the outside row on each side are of a form very different from those of the subsequent rows. As they take their origin from a plane surface, two of the sides necessary to complete the hexagon are cut off by this plane, so that the general form of the orifice is pentagonal; and the bottom of the cells on one side is composed of two equal rhombs only, and on the other side of two trapezoidal planes, with one rhomb. Such a modification of shape was necessary, in order to prepare the way for the regularly-formed cells which were to follow.

The foundations of the combs are laid by the bees raising a solid block or plate of wax of a semicircular form. In this they scoop out a small vertical channel, of the size of an ordinary cell. The sides of this channel are then strengthened by additions of wax. On the opposite side two other channels are formed, one on each side of the plane opposite to the former channel. The extremities of these channels, which at first present a curved outline, are then fashioned into straight walls, forming an angle at each vertex. The bottom of each cell being thus sketched out, the design is completed by raising walls round the sides. Different bees generally work on the opposite sides at the same time, and appear to have some perception of the thickness of the partitions, and of the situation of the opposite walls, in which they are perhaps guided by slight prominences, occasioned by the depressions which correspond to them on the other side; and they scrape off the wax in those places where its thickness is greatest, that is, where the bees on the other side had accumulated materials. In this way, then, in constructing the successive rows, the axis of each cell will be found to occupy the most retiring parts of the partition, and will be opposite to the junction of three of the opposite cells.

Soon after the bees have completed the foundations, and constructed a few of the cells of the central comb, they begin two others, one on each side, at the proper distance, and in this manner continue to form others in succession, in proportion as the former are advanced. Their object at first seems to be to extend the surface of the work so as to admit of the greatest possible number of workers being employed at one and the same time. In this way, then, the work proceeds from all points at once, new cells being begun before the former are completed, so that the whole

comb, while it is in progress of construction, has a semi-lenticular shape, broader at the top, and tapering below and towards the sides. It extends downwards, however, more rapidly than in any other direction, and its surfaces do not become parallel to each other till the last stage of the building process. When this is completed, the whole is further strengthened by an additional coating of propolis round the margin of all the cells; and the junctions of every plane, both of the sides and bottoms of the cells, are also soldered together by a lining of the same substance. The edges of the combs are also secured in their situations by being glued to the side of the hive and supported by fresh abutments of propolis. Sometimes a mixture of wax and propolis, manufactured by the bees themselves, is employed as the cementing material. The first coating of this compound substance is denominated *Commosis* by Pliny, and described as having a bitter taste; the second, or the *Pisoceros* of the same author, is stated to be of a thinner consistence, and more adhesive than the former; while the third substance, or *Propolis*, is completely solid.

The cells recently constructed are white, but become gradually darker, and, when very ancient, are almost black. It is therefore easy to distinguish in a hive the successive periods of formation of different portions of the combs. From the researches of Huber, it appears that these variations of colour are not owing to any changes in the wax itself, but to additional coatings of a peculiar varnish, consisting of propolis and a colouring matter. The latter differs materially from propolis, being wholly insoluble in alcohol. It loses its colour by the action of nitric acid or the light of the sun. Its origin has not yet been discovered, nor has the mode in which it is applied been clearly made out, although Huber presumes, from his observation, that the bees spread it by means of their mandibles, since he has seen them rub these against the sides of the cells, and noticed that they acquired a yellow colour from the operation.

Royal cells are only formed when it is necessary that queens should be reared, either from their being required to lead off swarms, or from the fact of the colony being queenless through accidental circumstances.

The comb of the hive may be said to be the furniture and storehouse of the bees, which by use must wear out; but, independently of this, it will in time become unfit for use, by the accumulation of cocoons, which are never removed. These line the whole cell, sides, and bottom. Hunter counted above twenty different linings in one cell, and found the cell about one-quarter or one-third filled up.

Lord Brougham made some interesting observations on the cells of bees. By boiling the comb in alcohol after it had been bred in, he succeeded in dissolving the wax, leaving the lining only, which was found to be an extremely thin transparent or semi-transparent film, resembling gold-beaters' skin, without a wrinkle. The linings from old cells with thick walls kept the shape of the cells most distinctly. They had angles and planes as well defined as those of wax in the new comb, but they did not consist of a single film like the cells where one brood only had been raised. They had one film within another, and could be separated, so that as many as five or six could be extricated from the same cell; each of these had the hexagon form, and the first two, and sometimes three, had the rhomboidal form of the base also, but the innermost ones had the rhombuses less and less distinctly marked, till the last one or two of all had spherical instead of pyramidal bases. The film adhered so closely to the wax as to defend it from the action of the solvent and even from that of heat, preventing it from melting for a considerable time. The film fitted the wax cells so completely that there never was found the least wrinkle or laxity, each being tensely

stretched in all its parts without any interval in any part. The whole of each cell was one entire piece of film going all round the prism and all through the pyramid without any breach, section, or joining; neither maceration nor even boiling in turpentine, ether, or caustic potash had any effect on the film.

A film of the same substance, transparent but considerably thicker, was found to line the queen-cells, assuming the pear or flask-like shape of the wax, and a very remarkable fact was observed. The film was not always in the inside; it sometimes lay imbedded in the wax, at least a layer of wax was laid over it of sensible thickness, indeed considerably thicker than some plates of the common cell, and sometimes much thicker. As a queen-cell is never used but once, never more than a single film can be found in it. How this lining is formed has never been satisfactorily determined, but it must be in one of two ways,—either by the larva forming a cocoon round itself and of an oblong figure inside, sufficient to contain it when it changes its position from a coil perpendicular to the axis of the cell into an oblong worm placed in the axis, or by the larva lining the walls of the cell. In the former case the cocoon, originally made somewhat of the shape of the larva, must afterwards be applied by it or by the chrysalis so as to line and adhere to the walls; in the latter case the walls are lined at first by the act of weaving or spinning. But there are difficulties attending both these hypotheses and the inferences to which they lead—inferences in either case as extraordinary, to say the least, as anything observed in the economy of the bee. If the cocoon is formed loose and round, then, when the transformation takes place, the pupa must press against every part of the cell, so as to apply the film all round and equally in every part. The extraordinary part is the perfect adaptation of the cocoon to the cell. There is no wrinkle whatever. It fits exactly in every part, both the planes and the dihedral angles and the trihedral angles. The extreme fineness of the texture may facilitate its fitting so many different shapes. But how is the size sufficient and not more than sufficient in any one place? If we only consider what extreme complexity and difficulty there would be in forming a cocoon—which should increase at every hair's breadth, and increase in a ratio varying at different points, and should, on reaching its maximum size, continue afterwards stationary in dimensions—we shall be convinced how insuperable the difficulties of the workmanship would be to any artist ever so expert or careful. But even this is not all, for as the web is to be afterwards by the supposition applied to the circumscribed walls, the extent of the curved surface of the cocoon inscribed must be less than that of the surface which it is afterwards to line if that curve is wholly concave to the axis, in other words, if it have no points of contrary flexure. In order, therefore, that it may be exactly equal to the walls which it is to fit exactly, the cocoon must be of a form wholly different from that of the larva that made it. It must be convex at some points and concave at others to the larva; it must be loose and baggy, and the progress of its bagging or being loose must vary at every point in order that when applied to the walls it may exactly fit them at every part. The performance of such a work by the larva appears scarcely conceivable. Astonishing as the known and ascertained works of the perfect insect are, this would surpass them in a proportion that might almost be called infinite. If we adopt the second inference, we get rid entirely of the former difficulty; for the operation of forming the film upon the walls is certainly much more easy. With the utmost nicety and precision, there is never a break to be found, and there is no part thicker than the rest, so that but one layer is applied everywhere; and the larva knows so ac-

curately where it has begun as always to leave off on coming round to that point without ever going again over the same ground for half a hair's breadth. The material is also very remarkable. A very high magnifying power shows no threads or separate pieces of any kind; in the great bulk of the texture, it is for the most part solid and perfectly transparent. There are interspersed irregularly a few fibres, but it should seem as if the whole was a mucilage spread over the walls rather than any webs of woven threads. But though the difficulties attending the other theory are not found in this, it has difficulties of a different kind and equally startling. The first that strikes us immediately is the use of the cocoon formed on the waxy walls. The cell was already made, and of the required form and dimensions, in which the larva could be lodged and grow and undergo its transformations. How was the lining it with the film to assist the process? If the cocoon had been of another form and wrapped round the larva, it might have served some such purpose of covering or support; but here the cocoon exactly fits the cell and in no wise alters its form, and only by an exceedingly small portion its capacity. And how are the second and subsequent cocoons to be accounted for? The cell had been already completely lined with the film, and the additional lining could add nothing to the advantage, whatever it was, which the first lining gave the larva and chrysalis. (See Brougham's *Works*, vol. vi. pp. 312-364.)

Such is the general outline of the architectural labours of the bee. A number of modifications are, however, met with, adapting them to various purposes and to new circumstances. The cells are required to be of different sizes for the nurture of different sorts of larvae. The smallest, which are also the most numerous, are appropriated to the larvae of the working bees; a larger sort receive those of the males; and a small number of very large cells are destined for the education of the young queens, and are therefore called royal cells. The first set are generally five and one-third lines in depth, and two and a half in diameter; the second are from seven to seven and a half lines in depth, and three and three-fourths in diameter; while the royal cells are above one inch deep, one-third of an inch wide, and their walls are much thicker than those of any other cells. Other cells, again, are set apart as magazines of honey or of pollen; they are made deeper than the common cells, sometimes as deep as two inches, and their axes are inclined to the horizon, so that their mouths are in the highest part, that their liquid contents may be more easily retained. When these are filled they are closed up by the bees with a wall of wax, and opened only when necessity requires.

The regularity of the cells is often disturbed in consequence of the admixture of rows of larger cells with those of smaller dimensions; but the pyramidal partitions are adapted by successive gradations to these changes, so that in many rows of what may be called cells of transition, the bottom presents four planes instead of three, two being trapeziums, and the other two irregular hexagons. These irregularities are met with chiefly in the combs most distant from the central one. When an abundant supply of honey induces the bees to lay up a large quantity in store, they build up for this purpose the walls of common cells, so as to give them a greater depth. The royal cells are often raised from the ruins of a number of other cells, which are destroyed to make room for them; they are usually built on the edge of some of the shorter combs, and often in the very centre of the hive. Sometimes there is but one; at other times as many as sixteen have been counted in the same hive. They are formed of a mixture of propolis and wax; their form is oblong, resembling that of a pear; their position is always vertical, so that



when they rise from the midst of other cells; they are placed against the mouths of those cells, and project beyond the common surface of the comb. They are perfectly smooth on the inner surface, while their outer side is covered with a kind of hexagonal fret-work, as if intended for the foundation of regular cells.

The impregnation of the queen-bee was formerly involved in the deepest obscurity, and has given rise to a multitude of very fanciful opinions. Some have denied that any intercourse with the male was necessary for the fecundation of the eggs. Swammerdam supposed that the mere effluvia proceeding from the males where they were collected in clusters was sufficiently active to produce this effect by penetrating the body of the female. Huber proved by decisive experiment that no such consequence resulted from these effluvia. Maraldi imagined that the eggs were fecundated by the drones after being deposited in the cells in the same way that the spawn of fishes is rendered prolific by the milk. Mr DeBraw of Cambridge gave an account, in a paper published in the *Philosophical Transactions*, of a milk-like fluid he had seen in the cells. But this appearance Huber showed to be a mere optical illusion arising from the reflection of light at the bottom of the cells. When the males are excluded from the hive the queen is as fertile and the eggs as prolific as when they are present. Hattorf supposed that the queen is capable of impregnating herself, an opinion which was supported by Schirach and Wilhelm, and was even favourably received by Bönnet, as it in some measure accorded with his discoveries respecting the aphid. Linnæus was of opinion that an actual union between the sexes took place, and Reaumur fancied he had seen this happen within the hive. There is, however, great reason to think he was mistaken. It has since been clearly proved that copulation takes place in the air during flight, and if the queen is confined to the hive either by bad weather, or malformation or mutilation of her wings, although she may be surrounded by drones, she never becomes impregnated; and if she does not find a mate within three weeks of her birth, the power of sexual intercourse seems to become lost. If a hive containing a virgin queen be attentively watched on fine days the queen will be observed preparing for her matrimonial flight, and after having attentively surveyed her home so as to be able to recognise it again she flies to a considerable height in the air; and if her errand is successful, in half an hour she returns to the hive with unequivocal proofs of the intercourse that has taken place, for she has in fact robbed the drone of the organs concerned in this operation; and the drone, thus mutilated, is left to perish on the ground. From its being necessary that the queen should fly to a distance in order to be impregnated, Huber infers the necessity of a great number of drones being attached to the hive, that there may be a sufficient chance of her meeting one of them during her aerial excursion.

The phenomenon that sometimes occurred in a bee-hive, of the queen laying eggs that produced males only, had for ages puzzled philosophers without any satisfactory solution, and it was reserved for Dzierzon to promulgate a new and startling theory of reproduction, which, in the words of its distinguished author, is said to have "explained all the phenomena of the bee-hive as perfectly as the Copernican hypothesis the phenomena of the heavens." Dzierzon first expressed his views upon the reproduction of bees in the year 1845. The principal points of this theory may be shortly expressed thus:—1st. That the queen (female bee), to become good for anything (i.e., to breed *workers*), must be fertilized by a drone (the male), and that the copulation takes place only in the air; that drone eggs do not require fecundation, but that the co-operation of the drone is abso-

lutely necessary when worker bees are to be produced; that in copulation the ovaries are not fecundated, but the seminal receptacle (or spermatheca), a little vesicle or sac opening into the oviduct, which in the young queen is filled with a limpid fluid, is saturated with semen, after which it is more clearly distinguishable from its white colour; and that the supply of semen received during copulation is sufficient for her whole lifetime. The copulation takes place once for all, and (as already stated) only in the open air; therefore no queen which has been lame in her wings from birth can ever be perfectly fertile, that is, capable of producing both sexes, as copulation never takes place in the interior of the hive. 2d. All eggs which come to maturity in the ovaries of a queen-bee are only of one and the same kind, and when they are laid without coming in contact with the male semen, become developed into male bees. This theory of Dzierzon's has since been amply confirmed by numberless experiments, although what power the queen possesses (or how she exercises it) of determining what eggs shall receive fecundation and what not, is yet a mystery. Certain it is that when the queen lays an egg in a drone cell, a drone is produced; and Von Siebold, who made many most skilful microscopical examinations of eggs, affirms that among fifty-two eggs taken from worker cells, examined by him with the greatest care and conscientiousness, thirty-four furnished a positive result, namely, the existence of seminal filaments, in which movements could even be detected in three eggs; and among twenty-seven eggs from drone cells, examined with the same care and by the same method, he did not find one seminal filament in any single egg either externally or internally. On the passage of the eggs from the ovary through the oviduct they pass the opening of the spermatheca, from which some eggs receive a portion of the seminal fluid,—these produce workers; other eggs pass without receiving the fluid,—these produce drones. What it is that governs the deposition or non-deposition of the seminal fluid on the egg is unknown. It has been suggested that the smaller diameter of the worker cells exerts some mechanical pressure on the queen's organs, which may cause the seminal fluid to be extruded as the egg passes, while the drone cells being larger this pressure is not by them exerted, and the egg passes un-fecundated. If the spermatheca of an impregnated queen be examined under the microscope its contents will be found to contain many thousands of spermatozoa, the characteristic movements of which are very visible. The contents of the spermatheca of a virgin or drone-breeding queen, similarly examined, will be found a limpid fluid only without a trace of spermatozoa.

The fact that the eggs of an unimpregnated queen will hatch and produce drones may be easily verified, and is now undisputed. By depriving a colony of its queen late in the year, a young queen will be reared; and the drones having been killed long before, no impregnation can take place, yet the queen will infallibly lay eggs which hatch into drones; these eggs are laid indiscriminately in drone and worker cells, the bees bred in the latter being stunted in their growth. If now the spermatheca be examined, no spermatozoa will be found present. The same result will be found if, in the summer, the virgin queen be deprived of her wings and so made unable to fly.

If the impregnation of the queen be delayed beyond, as elsewhere stated, the twenty-first day of her life, she becomes incapable of receiving impregnation, and begins soon after to lay the eggs of drones, and produces no other kind of eggs during her life. This very curious and unexpected fact was discovered by Huber; and has been satisfactorily established by his very numerous and varied experiments, although its explanation is perhaps

attended with insuperable difficulties. The abdomen of a queen that is unimpregnated is much more slender than that of one which is completely fertile; but, on dissection, the ovaries are found expanded and full of ova.

One of the most remarkable facts concerning the generation of bees, is the existence occasionally of prolific workers, the discovery of which we owe to Reims. Although it was doubted by Bonnet, its reality has been fully confirmed by the researches of Huber and subsequent observers, and it explains what was before inexplicable—the production of eggs in hives absolutely destitute of a queen. It is also remarkable that the eggs thus produced are always those of drones, but this is explained by the fact that these fertile workers have not received, and, in fact, are unable to receive, impregnation from the drone. The origin of these abnormal egg-layers is accounted for from their having passed the larva state in cells contiguous to the royal ones, and from their having at an early period devoured some portion of the stimulating jelly which was destined for the nourishment of the royal brood, their ovaries thus receiving a partial development; or when a colony is deprived of its queen late in the autumn, and an attempt to raise a queen from some unknown cause has failed, a larva has sufficiently advanced to develop into a fertile worker.

As soon as a sufficient number of cells have been constructed, the queen begins to deposit her eggs. Unlike most insects the queen-bee deposits eggs ten or eleven months in the year in temperate climates, although it is probable this is not the case when the winter is much more severe than in Britain. Young queens ordinarily commence ovipositing thirty-six hours after impregnation. What power, if any, the queen has in determining the sex of her eggs is unknown, but, as already noticed, eggs that will produce workers or queens will always be found laid in worker cells, and those that will produce drones will also be found in their appropriate cells. A queen of a new swarm will rarely produce drones the first year; instinct, seemingly, teaching her they will not be required. In the early spring, if a clean empty piece of drone comb be put into the centre of the brood nest, the queen will usually fill it with drone eggs, and this circumstance is taken advantage of by scientific apirians to secure a supply of drones for the impregnation of early hatched queens. When the eggs are about to hatch, the bees eagerly seek for that species of nourishment on which the larvae are to be fed. This consists of pollen with a proportion of honey and water, which is partly digested in the stomach of the bees, and made to vary in its quality according to the age of the young. The egg of a bee is of a lengthened oval shape with a slight curvature and of a bluish white colour. It is hatched without requiring any particular attention on the part of the bees, except that a proper temperature be kept up, in which case three days are sufficient for the exclusion of the larva. This has the appearance of a small white worm without feet, which remains generally coiled up at the bottom of the cell. The bees feed it with great assiduity with the kind of chyle above described, and in every respect exhibit towards it the greatest care and attention. Hunter says a young bee might easily be brought up by any person who would be attentive to feed it. As it grows up it casts its cuticle like the larvae of other insects. In the course of five or six days it has attained its full size, and nearly fills the cell in which it is lodged. It now ceases to eat, and the bees close up its cell with a covering of wax, or rather an admixture of wax and propolis, which they possess the art of amalgamating. During the next thirty-six hours the larva is engaged in spinning its cocoon, and in three days more it assumes the pupa state. It is now perfectly white, and every part

of the future bee may be distinguished through its transparent covering. In the course of a week it tears asunder its investing membrane, and makes its way through the outer wall of its prison in its perfect form. Reckoning from the time that the egg is laid, it is only on the twenty-first day of its existence that this last metamorphosis is completed. No sooner has it thus emancipated itself than its guardians assemble round it, caress it with their tongues, and supply it plentifully with food. They clean out the cell which it had been occupying, leaving untouched, however, the greater part of the web, which thus serves to bind together still more firmly the sides of the comb. The colour of the bee when it quits the cell is a light grey. For several days, sometimes a week or two after birth, the worker bees occupy themselves within the hive, not flying abroad during that time, their principal employment then being that of nurses; and many old observers thought them a different class altogether from the honey-gatherers and wax-makers. The metamorphosis of the male bee follows the same course, but requires four days longer for its completion, occupying twenty-five days from the time of the egg being laid to the attainment of the perfect state.

When from the egg or young larva it is the intention of the bees to raise a queen, their attention is more incessantly bestowed upon it, the cell being enlarged as elsewhere described. It is supplied with a peculiar kind of food, which appears to be more stimulating than that of ordinary bees. It has not the same mawkish taste, and is evidently acid. It is furnished to the royal larva in greater quantities than can be consumed, so that a portion always remains behind in the cell after the transformation. As a proof that any worker egg or young larva not more than three days old may be made to produce a queen, the experimenter has only to supply to such an one a portion of royal jelly, and the nurses will enlarge its cell and continue so to feed it, when in due time a queen will be produced. The growth of the larva and the development of all its organs are very much accelerated by this treatment, so that in five days it is prepared to spin its web, and the bees enclose it by building up a wall at the mouth of its cell. The web is completed in twenty-four hours; two days and a half are spent in a state of inaction, and then the larva transforms itself into a pupa. It remains between four and five days in this state, and thus on the sixteenth day after the egg has been laid, the perfect insect is produced. When this change is about to take place, the bees gnaw away part of the wax covering of the cell till at last it becomes pellucid from its extreme thinness. This not only must facilitate the exit of the bee, but may possibly be useful in permitting the evaporation of the superabundant fluids.

But the queen bee, although perfectly formed, is not always at liberty to come out of her prison, for if the queen-mother be still in the hive waiting a favourable state of the weather to lead forth another swarm, the bees do not suffer the young queens to stir out; they even strengthen the covering of the cell by an additional coating of wax, perforating it with a small hole through which the prisoner can thrust out her tongue in order to be fed by those who guard her. The royal prisoners continually utter a kind of plaintive cry, called by bee-keepers "piping," and this appears to be answered by the mother queen. The modulations of this piping are said to vary. The motive of this proceeding on the part of the bees who guard them is to be found in the implacable hatred which the old queen bears against all those of her own sex, and which impels her to destroy without mercy all the young queens that come within her reach. The workers are on this account very solicitous to prevent her even approaching the royal cells while there is any prospect of a swarm being about

to issue. They establish themselves as a guard around these cells; and, forgetting their allegiance on this occasion, actually beat her off as often as she endeavours to come near them. If, on the other hand, the swarming season is over, or circumstances prevent any further swarms from being sent off, the bees do not interpose any obstacle to the fury of the old queen, which immediately begins the work of destruction, transfixing with her sting one after the other the whole of the royal brood, while they are yet confined in their cells. It is observed by Huber, that the royal larva construct only imperfect cocoons, open behind, and enveloping only the head, thorax, and first ring of the abdomen; and he conceives that the intention of Nature in this apparent imperfection is, that they may be exposed to the mortal sting of the queen, to whom they may be given up as a sacrifice.

When the old queen has taken her departure along with the first swarm, the young queens are liberated in succession, at intervals of a few days, in order to prevent their attacking and destroying one another, which would be the infallible consequence of their meeting. This exterminating warfare is prevented by the vigilance of the bees which guard them, so long as new swarms are expected to go off. When a young queen is liberated, she is, like others of her sex, anxious to get rid of her rivals, and even at that early age seeks to destroy her sisters, which are still confined in the other royal cells; but as often as she approaches them she is bit, pulled, and chased without ceremony by the sentinels. But when the season is too far advanced for swarming, or if two or more queens should happen to emerge at the same moment, they mutually seek each other and fight till one is killed, and the survivor is immediately received as the sovereign of the hive. The bees, far from seeking to prevent these battles, appear to excite the combatants against each other, surrounding and bringing them back to the charge when they are disposed to recede from each other, and when either of the queens shows a disposition to approach her antagonist, all the bees forming the cluster instantly give way to allow her full liberty for the attack. The first use which the conquering queen makes of her victory is to secure herself against fresh dangers by destroying all her future rivals in the royal cells; while the other bees, which are spectators of the carnage, share in the spoil, greedily devouring any food which may be found at the bottom of the cells, and even sucking the fluid from the abdomen of the pupae before they toss out the carcasses.

We are now to direct our attention to the migrations of bees, by which new colonies similar to that which had originally peopled the parent hive are founded. The final causes of this phenomenon are sufficiently obvious, but it does not so clearly appear to what circumstances it is immediately owing. The increasing population of a hive probably occasions inconvenience from want of room; the increase of heat and the greater vitiation of the air become still more serious as the summer advances. The spring is, accordingly, the commencement of the swarming season. No swarming, indeed, will ever take place while the weather is cold, or until the hive is well stocked with eggs. The queen-bee, in consequence of the great number of eggs she has been laying, is now reduced to a more slender shape, and is well fitted for flight; her aversion for the royal brood, which she seems to foresee will in a short time become able to dispute the throne with her, and the vain attempts she makes to destroy them in the cradle, in which attempts she is invariably repelled by the bees who guard them, produce in her a constant restlessness and agitation which, as Huber represents it, rises to a degree of delirium. This frenzy, from whatever cause it may originate, is communicated to the workers; they may be seen hurrying to and

fro in the combs with evident marks of impatience. The heat of the hive is increased by their tumultuous movements; it sometimes rises suddenly on these occasions from 92° to above 104°. A general buzz is heard throughout the hive. This state of things occurs from time to time for some days before the swarm is actually on the wing; and the interval is occupied in making preparations for the approaching expedition; provisions are collected in greater quantity by the workers. Hunter killed several of those that came away, and found their crops full, while those that remained in the hive had their crops not nearly so.

On the day on which the swarm quits the hive, few of the workers roam to any distance, but several are seen performing circles in the air round the hive. The noise is on a sudden hushed, and all the bees enter the hive; this silence announces their immediate departure. A few workers appear at the door, turn towards the hive, and striking with their wings, give, as it were, the signal for flight. All those which are to accompany the expedition rush towards the door, and issue forth with wonderful rapidity, rising in the air and hovering for some time, as if in order to wait for the assemblage of the whole troop; then, having selected a rallying point, generally on some tree or bush, some alight, being joined immediately by others until the whole number is collected in one mass of bees. It does not always happen that the queen is the first to alight or is with the cluster at all; but if she be not there the bees soon discover it and disperse in search of her—if they fail to find her they return to the parent hive. Thither the queen sometimes, from weakness or other causes, returns, and is immediately attended by the rest. But if the weather be fine, the expedition is only deferred for one or two days, and they again take their departure. If their return be owing to the loss of their queen, they remain a fortnight or longer before the attempt to migrate is renewed, and then the swarm is much larger than before, which renders it probable that they have waited for the queen that was to go off with the next swarm. Sometimes, when everything indicates an approaching emigration, the passage of a cloud across the sun will suspend all their operations, and the previous bustle gives place to a state of perfect calm. But, if the day be not far advanced, the breaking out of sunshine will renew the commotion, and determine the moment of actual flight.

The swarm having rested for some time on the first landing-place, and collected the whole of its numbers, soars again in the air, keeping in a close phalanx, and directing its course with great velocity to the spot which their guides had selected,—giving out, at the same time, a loud and acute-toned hum by the action of their wings.

The parent hive, thus deserted by its queen and a large proportion of its inhabitants, is busily occupied in repairing its loss. The bees which remain quietly pursue their labours; the young brood, soon arriving at maturity, quickly fill up every deficiency; and young queens, being allowed their liberty, one after the other, conduct in their turns new swarms, in the same manner as the first. The second swarm is not sent off till after the space of from five to ten days after the first. The following swarms succeed quicker to each other, but consist of smaller numbers than the earlier ones. If it happen that two queens are found in a swarm, either the swarm divides itself into two, and have separate destinations, or a single combat between the queens decides on which of them the empire is to devolve. Sometimes, indeed, they appear not to perceive each other, and the parties belonging to each construct separate combs within the same hive; but no sooner do these combs come in contact, and thus give occasion to the queens meeting each other, than a contest begins which terminates only by the death of one of the rival queens.

Successive swarms are sent off as long as the increase of population permits; and the number thus produced in a season depends on a variety of circumstances, such as the abundance of flowers, the warmth of the climate, and capacity of the hive. Bosc, while he was French consul in Carolina, found a stock of bees in the woods which had been robbed of its wax and honey by the negroes; he contrived to convey the bees in his hat to a hive in his garden. He obtained from this hive eleven swarms before the end of autumn; and these, again, gave him the same number of secondary swarms, so that by the end of the year he had twenty-two hives stocked from the one he had thus saved from destruction. In Britain a hive commonly sends off only two and sometimes three swarms in the course of the summer; and prudent apirians will be satisfied with one swarm only, returning all subsequent ones to the parent hive, which would otherwise become very weak. When bar-frame hives are used, the issue of after-swarms is easily and surely prevented by destroying all queen-cells but one after the issue of the first swarm.

Very few drones accompany the new colonies, so that almost all those produced in the spring remain in the hive. But when the queens are impregnated, and no new swarms are about to take place, the workers, who had till then suffered them to live unmolested in the hive, are on a sudden seized with a deadly fury towards them, and a scene of carnage ensues. This usually happens in June, July, or August. They chase their unhappy victims in every quarter, till they seek a refuge at the bottom of the hive, where they collect in crowds, and are indiscriminately, and without a single exception, massacred by the working bees, who, with implacable fury, bite, maim, and throw them out of the hive. So great is their antipathy to all the race of drones, that they destroy, at the same time, the male eggs and larvae, and tear open the cocoons of their pupae, in order to devote them to one common destruction. This sacrifice of the males is not, however, the effect of a blind and indiscriminating instinct; for if a hive be deprived of its queen, the massacre does not take place, while the hottest persecution rages in all the surrounding hives. In this case the males are allowed to survive the winter.

Having thus got rid of the useless mouths which consumed, without any advantage to the public, a large portion of their provisions, the bees spend the remainder of the summer in collecting stores of honey and of pollen for the ensuing winter. Their gleanings are now less abundant than in the spring, and require more labour in the search and collection. But at this season the leaves of many kinds of trees, which are covered in the morning with a saccharine fluid that exudes from them, furnish them with a species of nourishment, which, though of very inferior quality to the nectarial fluid, still contributes to their support. Fruit is also attacked by bees, after the cuticular covering has been broken through by birds or snails. They also find nutriment in the *honey-dew*, which is an excrementitious fluid deposited on the leaves of plants by certain species of aphides. Often, however, these resources fail, and the hive is threatened with famine. On these occasions the distressed bees frequently betake themselves to plunder; and if a weak or queenless hive can be discovered they begin a furious onset, which costs great numbers their lives. If the invaders should fail in their attempt to force the entrance they retreat, and are not pursued by those whom they have assailed; but if they succeed in making good the assault, the war continues to rage in the interior of the hive until one side finds itself beaten, in which case, should the conquerors be the invaders, the invaded will generally join their forces, and help their late enemies to carry off their plunder, and at once become members of the lately hostile hive.

The life of a queen-bee will sometimes extend to three or four years, but her fertility decreases after her second breeding season. When absent from the hive on her matrimonial excursions she very often becomes a prey to a bird, and not seldom on her return mistakes her hive, when she is probably killed by the stranger bee, or by the queen on whose territory she has intruded. Drones seldom die a natural death; there is no evidence of the duration of the lives of individuals, but normally they are hatched about May and slaughtered by the workers in June, July, or August; should the hive be queenless, however, the workers do not harm the drones, and some will then live far into the winter or even to the following spring. The life of a worker is greatly dependent on the season of the year and the amount of labour performed. The modern method of introducing a fertile Ligurian queen (*Apis ligustica*) into a queenless stock of the common black bee (*Apis mellifera*), in order to obtain pure stocks of the former variety, has plainly demonstrated the short life of the worker bee. If the Ligurian queen be introduced in May, when bees are busy and work abundant, in from six to eight weeks thereafter scarcely a black bee will be found in the hive, although at the time of the introduction multitudes of young larvae were present, which probably would not all be fully developed for nearly three weeks; therefore, in the season of hardest work, the inhabitants of the hive would seldom attain the age of six weeks. But if the experiment of the queen's introduction be deferred until October, then not until the following May will the black bees have become extinct. And it is a curious fact that if a hive be deprived of its queen in October (and none other supplied), then the workers, having no labour to perform either in replenishing stores or attending on the larvae, will possibly in May be found still living, although somewhat reduced in numbers. Such a colony, however, generally becomes a victim to robbers when the activity of spring arrives, for a queenless stock rarely makes much defence of its stores. In fine winter days, when the sun shines brightly, numbers of bees are tempted abroad, which easily become benumbed by cold, fall to the ground, and die. Insectivorous birds also make victims of great numbers at such times, other insect food being scarce; so that, probably, in winter and early spring, more workers die from accident than by natural decay. The fecundity of the queen-bee is, however, adequate not only to repair these losses, but to multiply the population in a very high progression. *Apis ligustica* has the reputation of being more prolific than *A. mellifera*; and a young and vigorous queen will, in the fine weather of a warm May and June, deposit as many as 3000 eggs per day for several weeks in succession, and this fertility is of much longer continuance in America and other warm climates than in England. In England, eggs are deposited and young reared ten or eleven months in the year, when the colony is strong in numbers and well supplied with stores; but the increase in the cold months seldom equals the decrease by deaths.

The loss of the queen is an event which has the most marked influence on the conduct of the workers. Although the queen is constantly an object of attention and of affection to the whole community, they are not immediately sensible of her absence when she is removed from the hive. The ordinary labours are continued without interruption, and it is not till a whole hour has elapsed that symptoms of uneasiness are manifested, and it is even then only partially displayed. The inquietude begins in one part of the hive, the workers become restless, abandon the young which they were feeding, run to and fro, and, by striking each other with their antennae, communicate the alarming intelligence very quickly to their companions. The ferment soon extends to the whole community; the bees rush

precipitately out of the hive, and seek for their lost queen in every direction. This state of confusion continues for a day or two, after which tranquillity is again established; they return to their labours; and, selecting an egg, or one of the larvae that is not more than three days old, they break down two of the contiguous cells, sacrificing the larvae contained in them, and proceed to build up one royal cell from their ruins. They then supply the worm with the food necessary to promote its quick growth, and leaving untouched the rhomboidal bottom they raise around it a cylindrical enclosure. In three days the larva has grown to such a size as to require an extension of its lodging, and must inhabit a cell nearly of a pyramidal figure, and hanging perpendicularly. A new pyramidal tube is therefore constructed with the wax of the surrounding cells, which is soldered at right angles to the first, and the bees, working downwards, gradually contract its diameter from the base, which is very wide, to the point. In proportion as the worm grows, the bees labour in extending the cell, and bring food, which they place before its mouth and round its body, forming a kind of coiled zone around it. The worm, which can move only in a spiral direction, turns incessantly to take its food before its head; it insensibly descends, and at length arrives at the orifice of the cell. It then transforms itself into a pupa, is enclosed with a covering of wax, as before described, and, in the space of ten to sixteen days the original loss is thus repaired by the birth of a new queen. Schirach found that, if a number of bees be confined with even a single larva, which in the natural course would have become a worker bee they immediately set about giving it the royal education above described, and thus raise it to the dignity of queen.

The discovery that queens may be reared at will has been confirmed by recent experiment, and is now largely taken advantage of by apianians both in Europe and America, to facilitate the making of artificial swarms and otherwise increase the production of bees. By the aid of small frame hives called nucleus boxes, which only materially differ from the larger or mother hive by containing frames less in number and in size (generally three), a stock of fertile queens is kept on hand ready to supply any colony requiring a sovereign, or to exchange an old queen for a young one, or a Ligurian queen for an ordinary English one. An example of the method of rearing these queens is as follows:—A full comb containing young worker larvae and eggs is taken, with all its attendant bees, and placed in the centre of the nucleus box, flanked on both sides by other combs containing honey. Sufficient young bees, which have not flown, are now added to cover well the brood comb, in order that proper heat may be kept up to mature the brood. As soon as the members of this small community find themselves without a queen, a dreadful uproar ensues; and, probably, should there be bees among them who know their way home, they will desert, but enough will usually remain to carry on the desired work; if not, more young bees must be added. These may be known by their fresher and greyer appearance. After a few hours the commotion will subside, and the bees will proceed to the construction of royal cells, and take proper care for the feeding and hatching of the larvae selected for royal honours. Generally on the second day, the foundations of royal cells are perceptible, the number of these vary from one or two to as many as sixteen. In from ten to sixteen days, according to the age of selected eggs or larvae, the young queens will arrive at maturity; and as the first at liberty will destroy the others if allowed, the apianian in good time cuts out the sealed royal cells, which are distributed by grafting on other combs into newly-formed nuclei, or into such hives as require a queen. The young queens, on their emergence from the pupa state, are now

each at the head of a colony, where they remain until they become fertile in the natural way, and are then ready for such purposes as they are required for.

In Switzerland, Italy, and Germany a large business is done in Ligurian queen-raising for export. Great numbers of those queens come to England and America in little wooden boxes, accompanied by sufficient workers to develop enough heat. The price in Italy varies, according to the season, from five francs in October to twelve francs in March; but few are raised until May, owing to the difficulty of their obtaining impregnation. To overcome this difficulty in the autumn some colonies are purposely kept queenless, whose drones remain in existence. The advantage of having fertile queens at the bee-master's disposal is very great. When a swarm issues the young queen is not usually mature, and has to become impregnated. Should unfavourable weather ensue, a still further delay occurs; and the virgin queen, on her excursion, is liable to be lost or killed. Should no such accident occur, it may still be two or three weeks before ovipositing again commences, and this in the very height of the breeding season; while if the skilful bee-master, first taking the precaution to destroy any existing queen cells, can immediately, on the issue of the swarm, introduce the queen and her retinue from a nucleus hive, no time is lost, and probably 20,000 to 40,000 eggs will be deposited in the time that would otherwise have been lost. By this system of nucleus queen-rearing, it may be fairly calculated that the increase of population may be doubled. While the hive remains without a queen swarming can never take place, be the hive ever so crowded.

Huber has made the singular observation that two queens, however inveterate may be their mutual hostility, never actually destroy each other, and that when in the course of their contest they are placed in such a relative position that each has it in her power to strike a mortal blow on the other with its sting, they suddenly separate, and part with every appearance of being panic-struck. The final cause of the instinct that prompts this conduct is sufficiently obvious, as, without it, the hive would be altogether deprived of a queen.

Bees recognise the person of their own queen. If a stranger enter the hive, they seize and surround her until a ball of bees is formed one or two inches in diameter; in which imprisonment the unfortunate monarch is kept until death puts an end to her misery, for it is very remarkable the bees seldom sting a queen. A hive that has lost its queen may, however, by certain precautions be induced to accept a substitute. The most common way of attaining success in this operation is to imprison the stranger queen in a small cage of wire gauze or perforated zinc; this being suspended between two central combs or fixed upon one, the bees become accustomed to the odour and appearance of their new sovereign, and after the lapse of one or two days will readily accept her. If a supernumerary queen be introduced into the hive, she is laid hold of by the bees and presented to the reigning queen, while a ring is formed by the bees, who continue to be spectators, and even promoters of the combat, in which one or other of the queens is destined to perish. Schirach and Reims had imagined that, in these circumstances, the stranger met her death from the hands of the working bees, but this mistake has been corrected by Huber, who gives the account above stated.

We have next to relate the results of experiments of a more cruel kind, which illustrate several points in the physiology of these insects. The amputation of the four wings of the queen did not interfere with her laying eggs, and the workers did not show her the less attention on account of her being thus mutilated. Of course, if the

operation be performed before she is impregnated, she remains barren, since it is necessary for the sexual congress that she should fly out of the hive. The amputation of a single antenna appeared to be productive of no bad consequence of any kind; but the removal of both the antennæ was followed by singular effects. The queen which had suffered this operation ran about in apparent confusion, dropping her eggs at random, and was incapable of directing her tongue with precision to the food that was offered her. At times she appeared desirous of escaping from the hive; and when this was prevented, she returned in a state of delirium, was indifferent to the carcasses of the workers, and received another similarly mutilated queen that was presented to her without the least symptom of dislike. The workers, on the other hand, received the stranger queen with great respect, although the first still remained in the hive. A third queen, not mutilated, was next introduced; she was very ill received and immediately detained and kept a close prisoner, being evidently regarded as an intruder. When the queen deprived of her antennæ was allowed to quit the hive, she was followed by none of the workers, and was abandoned to her fate.

The wasp and the hornet have long been known as the determined enemies of the bee, committing great ravages among these weaker insects; they attack them individually, but oftener commit their aggressions in large armies, on which occasions numbers perish on both sides. In some parts of America wasps have multiplied to so great a degree as to render it impossible to rear bees. Among quadrupeds the ant-eater occasionally devours them. The bear and the badger overturn the hives, and plunder their contents. Rats and mice are very formidable enemies, as they attack the bees at all seasons, and especially during the torpid state of the insects, when they are incapable of revenging the aggression. The woodpecker may succeed in breaking through the hive, and then speedily destroys all its inhabitants; the swallow, the sparrow, the titmouse, the cuckoo, the *Merops apivora*, or bee-eater, and poultry of every kind, prey upon them separately. According to Boec. they are also food for the shrikes and for the *Falco apivorus*. Lizards watch for them, and seize them as they alight near the hive. Toads occasionally devour them. They are in some danger from the larger kinds of spiders, and of *Libellula*, as also from the *Philanthus apivorus* of Fabricius. But the most insidious and destructive enemies of the insects are moths, two species of which, *Galleria mellonella* and *Achroia grisella*, insinuate themselves into the hive, and deposit their eggs on the combs in such numbers, that the hive is soon overrun with the larvae, the combs destroyed, and the bees eventually forced to vacate the hive. In America and in Italy these moths are much more troublesome than in England. On the Continent of Europe bees are also troubled with a parasite called the bee-louse (*Braula cœca*), sometimes as many as 50 or 100 being found on a single bee, and as they live by suction they are great pests. This insect is not frequently found in England except accompanying imported Ligurian bees.

Bees are subject to few diseases, but these few are sometimes very fatal. Dysentery occasionally commits great havoc in a hive, and is usually caused by the neglect of sanitary measures, by close confinement, want of ventilation, and damp. Dysentery is indicated by the appearance of the excrement within the hive, which the bees in a healthy state are particularly careful to exclude. It is often induced by the bees being forced into undue excitement in cold, ungenial weather. The disease known generally by the name of "foul brood" is the most fatal of all; it is highly contagious,—the infection from its presence remaining in the hives, combs, and honey long after the bees are exterminated. Dysentery

is a disease of the perfect insects only. Foul brood is confined to the larvae, which, having grown to near maturity, die and putrefy after being sealed over by the bees. The workers seem totally unable to remove the foul mass which thus remains to spread infection all around. The seed of the disease is believed to lie in the presence of the spores of a microscopical fungus (*Micrococcus*), and long scientific discussions and experiments have been made on the Continent to demonstrate this, particularly by Drs. Frensch and Schönfeld. The devastation caused in apiaries by this disease is sometimes fearful. Dzierzon relates that, in 1848, he had nearly the whole of his colonies destroyed by it, more than 500 being destroyed, and only 10 escaping. Quinby also, in America, has lost as many as 100 stocks in a single year by this pestilence. And when once fully developed a total destruction of all hives and combs infected appears to be the only way of eradicating it. Honey from a foul brood hive will carry the germs of the disease to any bees which may consume it. The presence of this disease may be detected by the foul smell emanating from the hive, and from the circumstance of many cells remaining covered longer than naturally occurs when there are living pupæ within them.

In the management of bees a great deal must, of course, depend on supplying them with an abundant pasture. A rich corn country is well known to be to them as a barren desert during a great portion of the year. Hence the judicious practice of shifting them from place to place according to the circumstances of the season. It was the advice of Cæsar that, after the vernal pastures were consumed, bees should be transported to places abounding with autumnal flowers; and in accordance with that advice they were in ancient times annually carried from Achaia to Attica, and from Eubœa and the islands of the Cyclades to Scyrua. In Sicily, also, they were brought to Hybla from other parts of the island. So also in Scotland, so soon as the "bright consummate flowers" of summer are on the wane, the people of the Lowlands despatch their hives in cart-loads to the blooming heather of the mountain pastures, where a never-ending paradise of sweets is spread before them. It is, indeed, to be regretted that our moorlands are not more utilized for this object than they are. The very air of the Highland hills is often redolent with rich perfume, giving earnest of a bountiful harvest; only a solitary bee is seen here and there, labouring with wearied wing among the inexhaustible stores of nature, and scarcely able to regain with its burden its lonely abiding in the distant vale. Considering the poverty of the peasantry, and their frequent want of occupation, it is to be lamented that so easy and pleasant a source of emolument should be so much neglected by them. In consequence of this neglect a large sum is paid every year to foreign nations for articles that could be raised at home, in every respect superior, with very little outlay either of labour or of capital.

We learn from Pliny that the practice of removing bees from place to place was frequent in the Roman territories. "As soon," he says, "as the spring food for bees has failed in the valleys near our towns, the hives of bees are put into boats, and carried up against the stream of the river in the night, in search of better pasture. The bees go out in the morning in quest of provisions, and return regularly to their hives in the boats, with the stores they have collected. This method is continued till the sinking of the boats to a certain depth in the water shows that the hives are sufficiently full; and they are then carried back to their former homes, where their honey is taken out of them." And this is still the practice of the Italians who live near the banks of the Po, the river which Pliny instanced particularly in the passage above quoted.

M. Mallot relates, in his description of Egypt, that, "in spite of the ignorance and rusticity which have got possession of that country, there yet remain in it several footprints of the industry and skill of the ancient Egyptians. One of their most admirable contrivances is sending their bees annually into distant countries, in order to procure sustenance, at a time when they could not find any at home, and afterwards bringing them back,—like shepherds who should travel with their flock, and make them feed as they go. It was observed by the ancient inhabitants of Lower Egypt, that all plants blossomed, and the fruits of the earth ripened, above six weeks earlier in Upper Egypt than with them. They found that the same law applied to their bees; and the means they then made use of to enable these usefully industrious insects to reap advantage from the more forward state of nature there, were exactly the same as are now practised for the like purpose in that country. About the end of October, all such inhabitants of Lower Egypt as have hives of bees, embark them on the Nile, and convey them up that river into Upper Egypt, observing to time the journey so that they arrive there just when the inundation is withdrawn, the lands have been sown, and the flowers begin to bud. The hives thus sent are marked and numbered by their respective owners, and placed pyramidally in boats prepared for the purpose. After they have remained some days at their furthest station, and are supposed to have gathered all the wax and honey they could find in the fields within two or three leagues around, their conductors convey them in the same boats two or three leagues lower down, and there leave the laborious insects as long time as is necessary for them to collect all the riches of this spot. Thus the nearer they come to the place of their more permanent abode, they find the productions of the earth, and the plants which afford them food, forward in proportion. In fine, about the beginning of February, after having travelled through the whole length of Egypt, gathering all the rich produce of the delightful banks of the Nile, they arrive at the mouth of that river, towards the ocean, from whence they originally set out. They are now returned to their several homes, great care being taken to keep an exact register of every district from which the hives were sent in the beginning of the season, their numbers, the names of the persons who sent them, and likewise of the mark or number of the boat in which they were placed."

In many parts of France floating bee-houses are also common; there are on board one barge three to five score of bee-hives, well defended from the inclemency of an accidental storm. The owners allow their barges to float gently down the river, the bees continually choosing their flowery pasture along the banks of the stream, and thus a single floating bee-house yields the proprietor a considerable income. They have also a method of transporting their bees by land which is well worth imitation. Those hives being selected whose combs are firm and not likely to be broken by jolting, thirty to forty of them are carefully pecked in tiers in a cart, which proceeds slowly on its travels. If the season be sultry, they journey only at night, the hives being covered up with a cloth. On arriving in a suitable locality the hives are taken out of the cart, set upon the ground, and the bees go forth in search of food. In the evening, as soon as they are all returned, the hives are shut up, and being placed again in the cart they proceed on their journey. When the caravan has arrived at its destination, the colonies are distributed in the gardens or fields adjacent to the houses of the different peasants, who, for a very small remuneration, undertake to look after them.

On the continents of Europe and America bee-keeping is carried on in a much larger and more scientific manner than in the United Kingdom, where the cottagers still, in the greater majority of instances, use only the ancient straw skep or hive, and know no other method of depriving the colonies of their stores than the barbarous and wasteful practice of smothering them with brimstone. In Russia the province of Pultowa boasts of 500,000, and Ekaterinow has 400,000 hives. In Western Russia the industry chiefly flourishes in the province of Kowno, where the Tschude tribe are almost wholly engaged in bee-keeping; and in Eastern Russia the Finnic tribe are enthusiastic apiarists. In Siberia bee-keeping is mostly carried on about the Altai mountains, and in Caucasia by the Moresines and Grusinians. In Southern Russia artificial hives are used, while in North Russia the bees are kept in

a natural manner in the forests. The principal reasons why bee-culture is so industriously carried on in Russia are, first, because the peasants use honey instead of sugar, and, secondly, because wax tapers, to the value of 1,200,000 roubles are required for the churches. Mr Buschen states that the quantity of honey annually produced in European Russia is 600,000 to 700,000 lb. In Hungary and Germany apiaries of 2000 to 5000 colonies are said to be not infrequent; and great numbers are in the autumn often found congregated together on the heaths. In 1875 the aggregate number of stocks in Germany, including Hanover and Hesse Cassel, was found to be 1,453,764 stocks; Bavaria alone had 338,897. The German Government encourages bee culture in every possible manner; teachers, paid by the state, travel through the rural districts teaching the best methods of cultivation; and all schoolmasters, before receiving their diplomas, have to pass an examination in this subject. Bee-clubs in the villages are common, money for prizes and expenses being in part supplied by the Government. The result of this fostering care is that Germany produces many skilful apiarists, who contribute greatly to our knowledge of the science. In the United States bee-farming is largely carried on as a distinct trade, every scientific appliance being eagerly brought into use. The country also seems to be particularly productive of honey-secreting flowers, and consequently large harvests are gathered. In 1874 one bee-farm alone, that of Mr Harbison, situated in San Diego county, California, produced 150,000 lb of honey, of a market value of \$30,000, from 2000 stocks of bees. The honey-bee of both varieties (*Apis mellifica* and *A. ligustica*) has also been introduced into South Africa and New Zealand, where it flourishes amazingly.

#### Apiaries and Hives.

Having thus given at considerable length the natural history of the hive-bee, we proceed to describe the most approved hives, &c., in use in a well-managed apiary. Greater attention to this useful appendage to the cottage would not only be productive of commercial advantage, but would tend to improve the condition of the peasantry. It is not generally known, indeed, what profitable results may be obtained, at a trifling expense of time and labour, from bee-keeping. Even supposing the first cost of a swarm to be one guinea, which is a high price, the cottager, with proper care and management, will clear, in five years, a net profit of nearly £60, and have besides, at the end of that period, ten good stocks of bees in his garden.

The principal objects to be considered in the construction and management of an apiary, are, first, to secure the prosperity and multiplication of the colonies, and then to increase the amount of their productive labour, and to obtain their products with facility and with the least possible detriment to the stock. The apiary should afford to the bees shelter against moisture and the extremes of heat and of cold, and especially against sudden vicissitudes of temperature. The hives should render every facility for constructing the combs and rearing the young; they should allow of every part of the combs being occasionally inspected, and of their being removed when necessary; and, while due attention is paid to economy, they should be made of materials that will insure durability. Much ingenuity has been displayed by different apiarists in the construction of hives to unite in the greatest possible degree all these advantages; but there is still great room for improvement on the hives that are in common use.

While some cultivators of bees have been chiefly anxious to promote their multiplication, and prevent the escape of the swarms in the natural way by procuring what are termed "artificial swarms," which is effected by various means, others have taken into consideration only the

abundance of the products which they yield, and the best way of extracting them from the hive, without showing any particular solicitude as to the preservation of the bees themselves; still another class of apirians have had more particularly in view the prosecution of researches in the natural history and economy of bees. The hive invented by Huber was in his time a great advance for the purpose last named. He gave it the name of "ruche en livre ou en feuillets" from its opening and shutting somewhat in the manner of the leaves of a book. It had, however, many inconveniences which are remedied in some hives of more modern construction, and Huber's leaf-hive is now rarely used, although it may claim the distinction of having been the first of the frame hives which are now, with many modifications, generally acknowledged to be the only ones capable of giving the maximum of prosperity to the bees and producing a large honey harvest, combined with affording facilities for observation and manipulation. The old cylindrical straw skep or hive is still generally used among the cottagers of England, although abandoned in many other countries. While very excellent for warmth and ventilation, it has the disadvantage that its interior is inaccessible for information; and the fixity of its combs precludes many manipulations which the skilful apirian is called upon to perform. This was well known to the ancients, who, to remedy it, fitted the crowns of their hives with movable wooden bars, from which the bees built their combs, but still they were attached by their sides to the hive and required to be cut away before they could be removed,—these operations greatly disturbing the bees. In 1851, Deiarzon in Germany, and Langstroth in America, two of the most skilful apirians of the present day, simultaneously designed or invented the bar-frame hive, the principle of which, with many varieties of detail, is found in all the best hives now in use. A well-known English example of this kind of hive is the "Woodbury" (fig. 4), named after its designer, Mr Woodbury of Exeter. This consists of a square wooden box, 14½ inches in diameter (inside measure), and 9 inches deep, covered by a top or crown-board either loose or lightly screwed down. This board has a circular hole in the centre, 2½ inches in diameter, for feeding purposes, and when not in use is

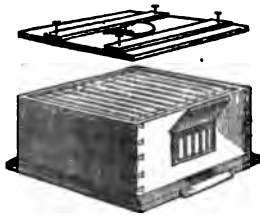

FIG. 4.—The Woodbury Frame Hive.

covered with perforated zinc or a block of wood. The floor-board is 18 inches square, with an entrance cut in it forming a channel about 4 inches wide and ¾ths of an inch deep. At the part where the front of the hive crosses it gradually slopes upwards inside the hive. An alighting-board for the bees is fixed to the front of the floor-board opposite the entrance, and projects 3 or 4 inches; a wooden ridge-roof covers all. The interior of the hive is fitted with ten frames; they are made of light lath, about ¼ths of an inch wide, the top bars being ¾ths and the sides and bottom rails ⅝ths of an inch in thickness respectively. The top bars are 15½ inches in length, and project into notches cut into rabbets at the back and front of the hive to receive them. The rabbets are ¼ths of an inch deep, and the notches in them are of the same depth, so that the projections in the bars rest flush in them, leaving a space of ¼ths clear above the frames, over which the bees can travel. The ten frames occupy equal portions of the interior space; if this be divided into ten equal divisions, the centre of each will be exactly the point at which the centre of each bar-frame should rest; these points will be 1-⅞ inches

apart. In these frames it is intended that the bees shall build their combs; and when they have done so, any frame may be quietly lifted out of the hive with all the bees upon it, whether for examination or for division of the stock for an artificial swarm. To induce the bees to build straight in the frames a thin strip of comb is usually attached to the underside of the top bar, or a thin line of molten wax poured down the centre of the bar will answer the purpose, as the bees will follow the guide thus laid. For the purpose of providing storage-room for honey an upper storey, called a "super," is added to the hive, of the same diameter but of less height, 3 to 5 inches usually sufficing, as when filled it may be taken off and an empty one substituted. Before a super be placed in position, the crown-board should be removed, and a thin board, called an "adapter," substituted; this, in place of the round central hole, has near each side a long aperture, ¾ths of an inch wide, which gives passage to the workers, but not to the queen and drones—the latter being useless there, and it being desirable the queen should not oviposit in the super.

Elegant supers are made of glass globes, or propagating glasses, which the bees will readily use if enticed into them by a few pieces of clean white comb.

Many improvements have been made on the Woodbury hive, tending still further to the comfort and well-being of the bees, as well as to the furtherance of scientific study; and, perhaps, the hive that may be said to combine most of these advantages is one designed by Mr Frank Cheshire, and known as the "Cheshire Hive" (figs. 5 and 6).

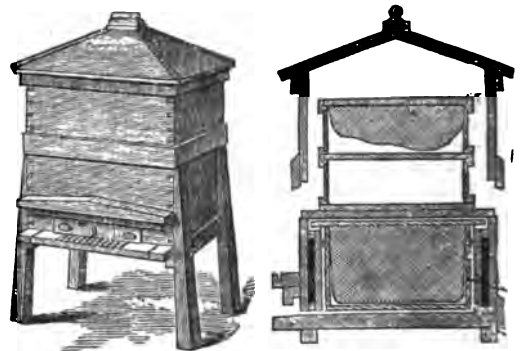

FIG. 5.—The Cheshire Frame Hive. FIG. 6.—Section of Cheshire Hive.

To afford the bees the maximum of comfort and to economize their heat, the walls of this hive are made double, enclosing an air space. The Woodbury frames are used, but rest on the thin edge of a strip of zinc within the hive at the back and front, which prevents the bees fixing them with propolis. The floor-board is constructed to slide in a groove beneath the hive, and the entrance can be enlarged or diminished at pleasure by a pair of sliding-shutters; the hive is complete with stand and roof, and altogether leaves little to be desired.

The adoption of frame hives has greatly facilitated the scientific study of the insects' habits, the artificial multiplication of colonies, and the appropriation of their surplus stores without injury to the bees. It is quite a secondary consideration what size or pattern of frame is used, or how the frames are suspended in the hive, provided the principle of movable frames be adopted; and although much ingenuity has been exercised by scientific men to design a hive embracing every possible advantage regardless of cost, the roughest timber and coarsest workmanship will give as good results as the most elaborate. Frame hives are exceedingly well calculated for procuring artificial



swarma. They allow us to judge by inspection whether the population be sufficient to admit of division, if the brood be of the proper age, if drones exist or are ready to be produced for impregnating the young queens,—all of which circumstances are material to the success of the operation. Wooden hives are generally made square, but not invariably so. The "Stewarton hive" (fig. 7), largely and successfully used in Scotland,

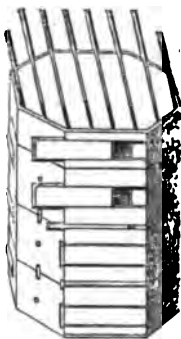

FIG. 7.—The Stewarton Hive.

is octagonal, and the "Quinby hive" of America is much deeper from back to front than it is wide. The Stewarton is not properly a frame, but a bar-hive, although frames are sometimes fitted to it. It usually consists of three octagon breeding-boxes, 14 inches in diameter by 6 inches deep, each furnished with nine bars placed equidistant, the spaces between being occupied by movable slides of wood working in grooves in the bars. The hive has shuttered windows back and front, handles to lift, and hooks to weigh with, as well as little buttons to prevent displacement; each breeding-box has an entrance-way 4 inches wide and half an inch high, with a sliding-door to close it wholly or partially. There are also two supers or honey boxes, the same diameter as the stock boxes, but only 4 inches deep; these are furnished with wider bars, seven in number, and a floor-board completes the whole, which, being made of but  $\frac{1}{4}$  inch wood, requires protection from the weather.

For those persons who are unable to handle bees with impunity, but are yet desirous of studying their economy, a glass covered observatory hive has been deemed a necessity. Several have been designed for this purpose, but none of them have been found to be a healthy abode for the bees,—glass being a cold and ungenial material, on which the moisture of the hive condenses during the winter to the detriment of health of the inhabitants. In the summer, however, bees may be kept in a glass hive without great loss, although with no gain; such a hive may be constructed of a double sash, thickly glazed back and front, of just sufficient width for one comb only and space to allow the bees free passage over both sides of the comb. A very excellent hive in English use is that known as the "Woodbury unicomb," which is so constructed that six frames may be taken out of an ordinary hive, and hung up in a double perpendicular row between the two sashes, permitting their return in the autumn to their original hive. Egress and ingress is given to the bees by a tunnelled channel to the centre of the hive on the floor line; and by means of a turn-table the hive may be revolved to bring both sides under alternate observation, together with all its inhabitants and their works. The common straw hive, or skep, of the cottagers is too well known to require description, and although it is greatly inferior to frame hives, it will doubtless long retain a place from its easy make and little cost. A great improvement now generally in use is the adoption of a round hole in the centre of the crown, about  $2\frac{1}{4}$  inches in diameter, which will permit the bees access to the super, and afford facilities to the bee-master for feeding his stock. The capacity of these hives should be about a bushel, when the apiary is situated in a good honey locality.

To a German apiarian we are indebted for the invention of a machine called the honey-extractor, which, with some subsequent improvements, forms a most important aid in large apiaries to increase the yield of honey. By this appliance the frames of full honeycomb are in a few seconds emptied of their contents without injury to the combs,

which are ready at once to be returned to the hive to be refilled, thus saving to the bees great labour in comb-building, and enabling them to take the utmost advantage of a favourable honey-time, which usually is but short. Honey is saved too, which the bees eat in comb-building; for it has been calculated that bees consume 20 lb of honey in producing 1 lb of wax. There are various patterns of the machine, but the principle of all may be said to be the same, that of centrifugal force. The apparatus consists of a cylindrical metal reservoir, with a tap at the bottom; and within is contained a perpendicular quadrangular frame, two sides of which are covered with wire-netting, and against these the full honeycombs, with their cells previously uncapped, are placed. This framework is then set revolving by means of a handle and cog-wheels, or other motive power, when the honey is flung out against the sides of the cylinder, and the combs completely emptied to be returned to the bees to clean and refill. The loss of this honey, and the excitement caused by the cleaning the wet combs, seem to induce the bees to work their hardest to replace their stores; and with a strong colony an enormous amount of honey is obtainable in a good locality and season. It has been recorded that one stock in America gathered 600 lb in a single season, and harvests of 200 lb and 300 lb are not uncommon there.

#### Bees-Keeping.

We shall now give a short exposition of the modern, humane, and scientific system of bee-keeping, which is probably destined at no distant day to supersede the ignorance and cruelty of past ages.

A description has already been given of examples of the best movable bar and frame hives, and the system they represent should alone be adopted, *i.e.*, every comb in the hives should be movable and interchangeable. In stocking these it is usual, first, to hive the swarm in an old-fashioned straw skep; and in the evening, after all the bees are quietly settled, suddenly to shake them down against the entrance of the hive or on the top of the frames, when the astonished insects will immediately take refuge in their future home. Should continuous bad weather occur after hiving a swarm, the bees must be fed, for, as they have as yet no stores, they will otherwise starve.

For feeding bees a multitude of appliances have been invented, but they may all give place to a common wide mouth pickle bottle; this is filled with syrup, the mouth tied over with a double fold of net, or placed inverted on a piece of perforated zinc or vulcanite over the feeding-hole of the crown-board of the hive. The supply can be regulated to the bees by the number and size of the holes through which they are allowed to suck. In cold weather when much moisture would be hurtful in the hive, barley-sugar may be advantageously used as a substitute for syrup. The former is made by boiling, for ten minutes, 2 lb of loaf-sugar in a pint of water, a little vinegar being added to prevent crystallization. The prosperity and profit of an apiary in a great measure depend on judicious feeding. It is bad economy to stint the bees in food. In the early spring slow and continuous feeding (a few ounces of syrup each day) will stimulate the queen to oviposit, by which means the stocks are rapidly strengthened and throw off early swarms. Upon the emergence of these, if a young fertile queen be immediately supplied, the hive is ready again to swarm in a remarkably short time. It is a singular fact that if stimulating feeding has been for some time pursued, and the supply be intermitted and nothing coming in from the fields, the bees will destroy all the young larvae and eggs, instinct seeming to teach the wise insects that the calls on the resources of the colony in the way of food for the young will be more than it can bear.

An abundant supply of water is essential to the healthy condition of bees. They consume a large quantity, and often stop to drink at the edge of stagnant pools, and seem even to prefer putrid and urinous waters to purer streams, as if their saline and pungent qualities were grateful to them.

Where the bee-keeper has the use of a honey-extractor, and a large produce of honey is his desideratum, the combs can be emptied as fast as they are filled; and at the close of the season the bees may be deprived of the whole of their honey if syrup be supplied to them in its place. This is of much less value, and answers every purpose for winter stores. No hive should be trusted to the exigencies of winter with a less weight of sealed comb than 15 lb. Honey may also be gathered into supers; and the bees in good seasons will readily build their combs there, but should be enticed to do so with a few pieces of nice white decoy-comb placed within. The management of the Stewarton hives may be described as follows:—Two of the breeding-boxes having had their bars furnished with guide-comb, are lashed together, the sliding-door of the upper one run in and the slides of the lower withdrawn, when the two boxes become virtually one; a prime swarm of bees is introduced, and eight or ten days thereafter, another prime swarm being hived in the third breeding-box, it is placed under the other two. The lower of the two first boxes, now the central, has its door run in and the slides of the lower withdrawn. The second swarm of bees will soon run up and fraternise with the others; and the next morning the lowermost box may be removed, and the entrance opened of the one above. The space provided by the two boxes will be found ample for breeding; and when full, the strong stock formed by the double swarm will soon be glad to occupy the super then to be added, to which communication should be afforded by withdrawing the outer slide on each side only. Should the season prove favourable the super will soon be filled, and when nearly so another should be placed on the top, and the first may be removed as soon as the honey cells are sealed over. All supers must be warmly wrapped up or padded, or the bees will be found reluctant to occupy them.

By the judicious management of supers, and the use of the honey-extractor, swarming may be in a great measure controlled; for if many swarms issue, the result must be that little honey will be gathered; all the energies of the reduced population being exerted to procure food for and attend to the young. A super put on the hive before the bees have made preparations for swarming by the construction of queen cells, &c., will generally prevent swarming, but not invariably. The bee-keeper must, therefore, decide whether he prefers an increase of his stocks or a large honey harvest, and manage his bees accordingly.

It often happens that bees give every indication of an intention to swarm, and cluster idly outside the hive in large numbers for days or even weeks before they really emigrate,—all this time keeping their owner in suspense; and possibly the swarm comes off at last without being observed. This is very tantalising, but may all be prevented by means of artificial swarming, the mode of proceeding for which varies according to the kind of hive in use. Considering, first, straw skeps, the common hive of the country, the operation to be pursued is known as "driving." This is not new, having been described by Dr Warder in the last century. The mode usually adopted is as follows:—Towards noon, on a fine day, when many of the bees are abroad, inject at the hive's entrance a puff or two of tobacco smoke, and with the hands give a smart smack on each side. The effect is that the whole of the inhabitants are struck with extreme terror; and after, perhaps, an alarmed rally to the entrance, every bee rushes to the cells to fill itself with honey. Allowing two or three minutes for them to effect their

purpose, the hive is boldly inverted and an empty hive of the same size placed on it mouth to mouth. A long towel is now bound round the junction to confine the bees, and the operator, with two sticks or the palms of his hands, keeps up a continuous smart rapping on the sides of the full hive, and after a few minutes the bees will all stream up into the empty hive, generally not more than fifteen minutes having elapsed before the first hive is denuded of its inhabitants. It should now be placed on the stand of some other strong stock (previously removed), whose returning bees will form a population to nurse the young and rear a queen if one be not supplied by the apiarian. If the swarm is to be at once sent away to a distance exceeding 1½ miles, the hive may be returned to its old stand, and so be peopled by the remainder of its old inhabitants who were at work. But if the swarm is to remain near, it should be placed on the old stand, as the bees, on their next flight, will return to the locality they know so well. "Driving" should also be pursued in the autumn, when it is desired to appropriate the honey of the hive. The driven bees should then be added to another stock, which they will advantageously strengthen. Where frame hives are in use, the following method may be adopted:—First, lift out the frames and search until the queen be found, when she, with the frame she is on, must be placed in the centre of a new hive, and be flanked on both sides by another comb as full of sealed brood as can be obtained. Fill up both hives with new frames furnished with empty combs, or guide-combs only if the former be not available, and shake into (or before the entrance of) the hive where the queen is sufficient bees to form a large swarm. Many will fly back to their old home, but all the young bees will remain. This hive should then be removed to some distance and the old one replaced. If the swarm is to be sent to a distance, the bees may be simply shaken off the combs into (or in front of) a new hive (taking care the queen is with them), which should be temporarily placed on the spot where the old one has just stood. The bees will enter it, and when all is quiet it should be removed and the old one reinstated. The bees that return from the fields will form a population for the domicile which they will find in the familiar place. Before in any manner operating on bees, it is advisable to puff a little smoke into the hive. This alarms them and causes them to fill their honey-pouches, and a bee in this state never volunteers an attack; but it is always prudent to cover one's face and hands, as home-returning bees are sometimes inclined to resent the disturbance to their family. India-rubber gloves, with gauntlets and veil of leno, will afford ample protection; the latter should be a simple bag, open at top and bottom, but with half a yard of elastic sewn in the top, through which should be passed the crown of a broad-brimmed hat; the coat should be buttoned over the lower part. Bee-keepers who meddle much with their bees soon become accustomed to stinging and do not suffer much. Experiments have been made to ascertain the number of stings required to inoculate the blood, and it has been stated that about thirty, at the rate of three or four a day, will suffice, after which the effect of the bee-poison is trivial. Persons unaccustomed to the poison, however, often suffer severely.

We conclude by observing that the honey-bee (*Apis mellifica*) is supposed to be of Asiatic origin. It was imported from Europe to America, where it is now found wild in great numbers, and at a vast distance from human habitations. An excellent treatise, *The Honey-Bee, its Natural History, Physiology, and Management*, was published in 1827 by Dr Edward Bevan. It contains some of the best practical remarks on the subject that are anywhere to be met with, and gives a fair account of the labours of the author's predecessors, Reesamur, Hunter,

Huber, Keys, Viest, and Dunbar. The Rev. L. L. Langstroth, of New York, has also written a very excellent volume on *The Hive and Honey-Bee*. To Pastor Dmerson, the Baron von Berlepsch, and Von Siebold of Germany, we are indebted for many accurate and valuable observations on physiology and hive management; and a *Manual of Bee-keeping*, written in 1875 by Mr John Hunter,

secretary of the British Beekeepers' Association, contains much practical information on scientific and profitable bee-keeping. We may add that the above association, established in 1874 under the presidency of Sir John Lubbock, is the first vigorous effort made in England to extend and improve this neglected although valuable branch of rural economy. (J. N.)

**BEECH**, a well-known tree, the *Fagus sylvatica*. For the cultivation and properties of it see **ARBOREICULTURE**, vol. ii. p. 317. The name beech is from the Anglo-Saxon *bec*, *bece*, or *beoce* (Ger. *Buche*, Swedish, *bok*), words meaning at once a book and a beech-tree. The connection of the beech with the graphic arts is supposed to have originated in the fact that the ancient Runic tablets were formed of thin boards of beech-wood. "The origin of the word," says Pries (Popular Names of British Plants), "is identical with that of the Sanskrit *bôks*, letter, *bôkde*, writings; and this correspondence of the Indian and our own is interesting as evidence of two things, viz., that the Brahmins had the art of writing before they detached themselves from the common stock of the Indo-European race in Upper Asia, and that we and other Germans have received alphabetic signs from the East by a northern route, and not by the Mediterranean." Beech-mast, the fruit of the beech-tree, was formerly known in England as buck; and the county of Buckingham is so named from its fame as a beech-growing country. Buckwheat (*Buchensisen*) derives its name from the similarity of its angular seeds to beech-mast. The generic name *Fagus* is derived from *φάγος* to eat; but the *φάγος* of Theophrastus was probably the sweet chestnut (*vesalius*) of the Romans. Beech-mast has been used as food in times of distress and famine, and in autumn it yields an abundant supply of food to park-deer and other game, and to pigs, which are turned into beech-woods in order to utilise the fallen mast. In France it is used for feeding pheasants and domestic poultry. Well-ripened beech-mast yields from 17 to 20 per cent. of a non-drying oil, suitable for illumination, and said to be used in some parts of France and other Continental countries in cooking, and as a substitute for butter.

**BEECHY, FREDERICK WILLIAM**, a distinguished naval officer and navigator, son of Sir William Beechey, R.A., was born in London, in 1796. In 1806, at the age of ten, he entered the navy, and was for several years engaged in active service during the wars with France and America. In 1818 he served under Franklin in Buchan's Arctic expedition, of which at a later period he published a narrative; and in the following year he accompanied Parry in the "Hecla." In 1821 he took part in the survey of the Mediterranean coast, under the direction of Captain, afterwards Admiral, Smyth. He and his brother, H. W. Beechey, made an overland survey of the north coast of Africa, of which a full and valuable account was published in 1827. In 1825 he was appointed to the "Blencorn," which was intended to explore Behring's Straits in concert with Franklin and Parry. He passed Behring's Straits and penetrated as far as lat. 71° 25' 31" N., and long. 156° 21' 30" W., reaching a point only 146 miles west of that reached by Franklin's expedition from the Mackenzie River. The whole voyage lasted more than three years; and in the course of it Beechey discovered several islands in the Pacific, and an excellent harbour near Cape Prince of Wales. A full narrative of his voyage was published in 1825-28. From 1835 to 1847 Captain Beechey was employed on the coast survey of South America and Ireland. He was then appointed by Government to preside over the Marine Department of the Board of Trade. In 1854 he

was made rear-admiral, and in the following year was elected president of the Geographical Society. He died on the 29th Nov. 1856.

**BEECHEY, SIR WILLIAM, R.A.**, a fashionable portrait-painter, born at Burford in December 1753, was originally bred as a conveyancer, but a strong love for painting induced him to become a pupil at the Royal Academy in 1772. Some of his smaller portraits gained him considerable reputation; he began to be employed by the nobility, and in 1793 became associate of the Academy. In the same year he was made portrait-painter to Queen Charlotte, an appointment which increased his celebrity. He painted the portraits of the members of the royal family, and of nearly all the most famous or fashionable persons of the time. What is considered his finest production is a review of cavalry, a large composition, in the foreground of which he introduced portraits of George III., the Prince of Wales, and the duke of York, surrounded by a brilliant staff on horseback. It was painted in 1798, and obtained for the artist the honour of knighthood, and the rank of R.A. The earlier portraits of Beechey were carefully drawn and well finished; but in his later days the extent of his employment rendered him less careful in his design. His works are generally vigorous, but are wanting in grace and dignity. He was a good, but not an eminent portrait painter. He died in January 1830, at the advanced age of eighty-six.

**BEELEZEBUB**. The name of the supreme god among all the Syro-Phœnician peoples was *Baal*, i.e., *lord* or *owner*; and by adding to it *sebul*, insect, the proper name *Baalzebub* was formed, the god of Ekron according to 2 Kings i. 2, the fly-god, the avorter of insects, similar to the *Zeus ἐπιθνήσκων, μύιαγρος*, and the Hercules *μύιαγρος*; so that Clemens Alexandrinus speaks of a Hercules ἐπιθνήσκων worshipped in Rome. Hug's hypothesis that this Phœnician god was the dung-beetle, the *Scarabæus pœlularius*, worshipped in Egypt, cannot be accepted. *Beelzebub* was so named not from his form, but from his supposed power of driving away noxious flies. In the New Testament the word is applied to Satan, the ruler or prince of the demons (Matt. x. 25, xii. 24, 27; Mark iii. 22; Luke xi. 15, 18, 19). But the best Greek MSS. read *Βεελζεβούλ*, *Beelzebub*, in the Gospels,—an orthography followed by the latest critical editions, though the Syriac and Vulgate versions have *Beelzebub*, which is also recommended by Jerome. What is the origin of *Beelzebub*? The most obvious derivation of it is *בַּלְזְבוּב*, *Baal* (or *lord*) of the dwelling, a name of Saturn among the Phœnicians, according to Movers, synonymous with *בַּלְזְבוּב*. So it may mean *Baal of the heavenly dwelling or habitation*, just as Satan is termed in the epistle to the Ephesians (ii. 2) "prince of the power of the air." Others suppose that *Beelzebub* arose from *Beelzebub* by a pun on the part of the later Jews, who wished to throw ridicule on idols by forming the appellation *lord of dung*,—*בַּלְזְבוּב* or *בַּלְזְבוּב* meaning *dung* in the Targumic and Talmudic dialects. This is improbable, because *Beelzebub* was not a current name in Jewish literature. Somewhat different is the opinion of Lightfoot, based upon various Talmudic passages, in which *sebul*,

*dung*, or a *dunghill*, is applied to an idol or idolatry and the verb *לָדַג*, to *dung*, to sacrificing to an idol,<sup>1</sup> so that *בְּלִצְבֻל* is not a proper name, but a general and common one, equivalent to the *lord of idolatry*, *prince of the demons*, the most devilled of all devils — *ἀρχὴν τῶν δαιμονίων*. In this way the word *לָדַג* has the secondary sense of *idol*, and Beelzebub has no connection with the proper name Beelzebub. The passages in question are far from supporting the hypothesis. *Sebul* is not a Hebrew word. It has not the sense of *idol* in Chaldee. In the Targums *sebul* has no other signification than *dung*. A nickname or opprobrious epithet is not a real name or the signification of a word properly so called. All that the quotations fairly imply is, that an ignominious name was sometimes given to idols or idolatry, *dung*, or a *thing of dung*. Hence Lightfoot and those who follow him, such as Gesenius and Sohlensner, are in error. If *sebul* be a part of the name Beelzebub added to it designedly, it is more probable that it was meant to express contempt for a leading god of the heathen. But it is exceedingly doubtful whether it was common as early as the New Testament. According to the Gospels, the Jews attributed the power of expelling demons which Jesus possessed to his connection with Satan, the ruler of the demons; and their notions of Satanic influence forbid the idea of applying the name *dung-god* (if such was its meaning) to a being like the devil. We reject the two leading derivations of the word Beelzebub, whether that sanctioned by Lightfoot and Buxtorf, *lord of dung*, which is adopted by Fritzsche and De Wette; or *lord of the dwelling*, followed by Paulus, Jahn, and Hitsig. Meyer ingeniously supposes that the latter is favoured by the words of Matthew x. 25, where *ὀκκοδεσπότης* is thought to be assigned to Jesus significantly, in allusion to *Βεελζεβούλ*; and as *δεσπότης* corresponds to *לָדַג*, an analogous word must be found for *ὀκος*, viz., *לָדַג*. The reasoning, however, is fallacious. The reading in Matthew x. 25 is not certain,—Lachmann following the Vatican MS. in giving *τῷ ὀκκοδεσπότῃ* instead of the usual *τῷ ὀκκοδεσπότῃ*. Then, again, the passage is unique in saying that the Jews gave Jesus the surname Beelzebub. We learn from Matth. xii. 24 that they said he cast out demons “by Beelzebub, prince of the demons,” which does not agree with x. 25, but is a more intelligible and likely statement. That they actually called Jesus Beelzebub is a doubtful assertion, notwithstanding Meyer’s affirmation to the contrary. The change of the final letter from *b* to *l* seems to have been accidental. Such alterations are not unusual, as Bab-el-mandel from Bab-el-mandeb, Rabbuli from Rabbuni, Ambakum from Habakkuk. *L*, being a softer sound than *b*, was a natural change. Why the name Beelzebub was applied to Satan at the time of Christ is obscure. Probably it originated in no specific reason. The appellation of a leading god was readily transferred to the devil. It is therefore idle to inquire on what grounds the Jews assigned to the Beelzebub of Ekron the peculiar position of “prince of the demons.” The Philistine god had become but a name.

Lightfoot’s *Hors Hebraica et Talmudica*, Works, vol. ii. pp. 188, 189, 429, ed. Strype, 1684; Selden, *De die Syris*, Syntagma, ii. cap. vi. p. 301, &c., ed. Lugd. Bat. 1629; Gesenius, articles “*Bel*” and “*Beelzebub*” in *Erck und Gruber’s Encyclopædie*; Buxtorf, *Lexicon Chaldaicum Talmudicum et Rabbinicum*, pp. 333, 334; Winer’s *Realwörterbuch*, s. vv. “*Beal*,” “*Beelzebub*,” Merz in *Schubert’s Bibel-Lexicon*, vol. i. p. 329; De Wette’s *Kritisch-exegetisches Handbuch des N. T.*; Meyer’s *Kommentar ueber das Neue Testament*; Movers’s *Die Phœnizier*, i. p. 260. (S. D.)

**BEER.** See **BREWING**.

**BEERSHEBA**, now **BIR-ES-SABA**, a place in the southern-

most part of Canaan, 27 miles S.E. from Gaza, celebrated for the sojourn of the patriarchs. The name, signifying the *well of the oath*, was bestowed in allusion to the covenant made there between Abraham and Abimelech, and is frequently referred to in the Scriptures in describing the extent of the country—“*from Dan to Beersheba*.” The place is mentioned by Eusebius and Jerome in the 4th century as a large village, and the seat of a Roman garrison. At a later period it seems to have been one of the episcopal cities of Palestine, and some of its churches were standing in the 14th century. Hardly any remains of its buildings are now left, but its two wells are still open, and afford an abundant supply of pure water, which stands in the larger at a depth of 44 feet, and in the smaller at a depth of 12. (See Robinson’s *Researches*, i. 301.)

**BEET.** A considerable number of varieties of the genus *Beta* (Nat. Ord. *Chenopodiaceae*) are cultivated for use on account of their large fleshy roots. The beets which are grown as root-plants, under the names of mangel-wurzel or mangold, field-beet, and garden beet, are generally supposed to be cultivated varieties of the sea-beet (*B. maritima*). The cultivation of beet as a field crop is treated under **AGRICULTURE** (vol. i. p. 381); and in relation to the production of sugar, for which purpose certain varieties of beet stand next in importance to the sugar cane, see **SUGAR**. The garden-beet has been cultivated from very remote times as a salad plant, and for general use as a table vegetable. The variety most generally grown has long, tapering, carrot-shaped roots, the “flesh” of which is of a uniform deep red colour throughout, and the leaves brownish red. It is boiled and cut into slices for being eaten cold; and it is also prepared as a pickle, as well as in various other forms. Beet is in much more common use on the Continent as a culinary vegetable than in Great Britain, where it has, however, been cultivated for upwards of two centuries. The leaves of the white Sicilian beet and the Swiss chard beet, both varieties of *Beta cicla*, are used for salads and otherwise as culinary vegetables.

**BEETHOVEN**, **LUDWIG VAN**, is in music what Shakespeare is in poetry, a name before the greatness of which all other names, however great, seem to dwindle. He stands at the end of an epoch in musical history, marking its climax; but his works at the same time have ushered in a new phase of progress, from which everything that is great in modern music has taken its rise. This historic side of his genius will have to be further dealt with when the progress of musical art is traced in its continuity. (See article **MUSIC**, historic section.) At present we have to consider Beethoven chiefly as a man and an individual artist, showing at the same time the reciprocal relations between his life and his work. For although the most ideal artist in that most ideal of arts—music—he is always inspired by the deepest sense of truth and reality. The grand note of sadness resounding in his compositions is the reverberation of personal suffering. He was a great artist only because he was a great man, and a sad man withal.

The family of Beethoven is traceable to a village near Lowen in Belgium, in the 17th century. In 1650 a member of this family, a lineal ancestor of our composer, settled in Antwerp. Beethoven’s grandfather, Louis, owing to a quarrel with his family, left Belgium for Germany, and came to Bonn in 1732, where his musical talents and his beautiful voice did not long remain unnoticed. The archbishop of Cologne, an art-loving prelate, received him amongst his court-musicians; and the same position afterwards was held by Ludwig’s son, Johann, our composer’s father. The latter was married to Maria Magdalena Keverich, daughter of a cook, and widow of a *valet-de-chambre* of the elector of Trèves. The day of our composer’s birth is uncertain; he was baptised Dec. 17, 1770, and received

<sup>1</sup> See *Hierocli. Berochoth*, fol. 12, 13; and *Midrash Shir*, fol. 2. 1.

the name of his paternal grandfather Louis, or, in its Germanized form, Ludwig. Beethoven himself seems to have considered the 16th December of the said year his birthday, but documentary evidence is wanting. At one period of his life he believed himself to have been born in 1772, being most likely deceived on the point by his father, who tried to endow his son and pupil with the *prestige* of miraculous precocity. No less uncertain than the date is the exact place of the great composer's birth; two houses in Bonn claim the honour of having been the scene of the important event. The youth of Beethoven was passed under by no means happy circumstances. His father was of a rough and violent temper, not improved by his passion for intoxicating drink, nor by the dire poverty under which the family laboured. His chief desire was to reap the earliest possible advantage from the musical abilities of his son, who, in consequence, had at the age of five to submit to a severe training on the violin under the father's supervision. Little benefit was derived from this unsystematic mode of instruction, which, fortunately, was soon abandoned for a more methodical course of pianoforte lessons under a musician of the name of Pfeiffer. Under him and two other masters, Van der Eden and Neefe, Beethoven made rapid progress as a player of the organ and pianoforte; his proficiency in the theoretical knowledge of his art the aspiring composer soon displayed in a set of Variations on a March published in 1783, with the inscription on the title-page, "*par un jeune amateur, Louis van Beethoven, âgé de six ans*," a statement the inaccuracy of which the reader will be able to trace to its proper source. In 1785 Beethoven was appointed assistant of the court-organist Neefe; and in a *catalogue raisonné* of the musicians attached to the court of the archbishop, he is described as "of good capacity, young, of good, quiet behaviour, and poor." The elector of Cologne at the time was Max Frans, a brother of the Emperor Joseph, who seems to have recognized the first sparks of genius in the quiet and little communicative youth. By him Beethoven was, in 1787, sent for a short time to Vienna, to receive a few lessons from Mozart, who is said to have predicted a great future for his youthful pupil. Beethoven soon returned to Bonn, where he remained for the next five years in the position already described. Little remains to be said of this period of apprenticeship. Beethoven conscientiously studied his art, and reluctantly saw himself compelled to alleviate the difficulties of his family by giving lessons. This aversion to making his art useful to himself by imparting it to others remained a characteristic feature of our master during all his life. Of the compositions belonging to this time nothing now remains; and it must be confessed that, compared with those of other masters, of Mozart or Handel, for instance, Beethoven's early years were little fertile with regard either to the quantity or the quality of the works produced. Amongst the names connected with his stay at Bonn we mention only that of his first friend and protector, Count Waldstein, to whom it is said Beethoven owed his appointment at the electoral court, and his first journey to Vienna. To the latter city the young musician repaired a second time in 1792, in order to complete his studies under Haydn, the greatest master then living, who had become acquainted with Beethoven's talent as a pianist and composer on a previous occasion. The relation of these two great men was not to be fruitful or pleasant to either of them. The mild, easy-going nature of the senescent Viennese master was little adapted to inspire with awe, or even with sympathy, the fiery Rhenish youth. Beethoven in after life asserted that he had never learned anything from Haydn, and seems even to have doubted the latter's intention of teaching him in a proper manner. He seems to have had more confidence in the instruction of Albrechts-

berger, a dry but thorough scholar. He, however, and all the other masters of Beethoven agree in the statement, that being taught was not much to the liking of their self-willed pupil. He preferred acquiring by his own toilsome experience what it would have been easier to accept on the authority of others. This autodidactic vein, inherent, it seems, in all artistic genius, was of immense importance in the development of Beethoven's ideas and mode of expression.

In the meantime his worldly prospects seemed to be of the brightest kind. The introductions from the archbishop and Count Waldstein gave him admittance to the drawing-rooms of the Austrian aristocracy, an aristocracy unrivalled by that of any other country in its appreciation of artistic and especially musical talent. Vienna, moreover, had been recently the scene of Mozart's triumphs; and that prophet's cloak now seemed to rest on the shoulders of the young Rhenish musician. It was chiefly his original style as a pianist, combined with an astonishing gift of improvisation, that at first impressed the amateurs of the capital; and it seems, indeed, that even Haydn expected greater things from the executive than from the creative talent of his pupil. It may be added here, that, according to the unanimous verdict of competent witnesses, Beethoven's greatness as a pianoforte player consisted more in the bold, impulsive rendering of his poetical intentions than in the absolute finish of his *technique*, which, particularly in his later years, when his growing deafness debarred him from self-criticism, was somewhat deficient.

As a composer Beethoven appeared before the public of the Austrian capital in 1795. In that year his Three Trios for Pianoforte and Strings were published. Beethoven called this work his *Opus 1*, and thus seems to disown his former compositions as juvenile attempts unworthy of remembrance. He was at that time twenty-five, an age at which Mozart had reaped some of the ripest fruits of his genius. But Beethoven's works are not like those of the earlier master, the result of juvenile and all but unconscious spontaneity; they are the bitter fruits of thought and sorrow, the results of a passionate but conscious strife for ideal aims. Before considering these works in their chief features, we will add a few more remarks as to the life and character of their author. The events of his outward career are so few and of so simple a kind that a continuous narrative seems hardly required. The numerous admirers whom Beethoven's art had found amongst the highest circles of Vienna,—Archduke Rudolf, his devoted pupil and friend, amongst the number,—determined him to take up his permanent residence in that city, which henceforth he left only for occasional excursions to Baden, Mödling, and other places in the beautiful surroundings of the Austrian capital. It was here, in his lonely walks, that the master received new impulse from his admiring intercourse with nature, and that most of his grandest works were conceived and partly sketched. Except for a single artistic tour to Northern Germany in 1796, Beethoven never left Vienna for any length of time. A long-projected journey to England, in answer to an invitation of the London Philharmonic Society, was ultimately made impossible by ill-health. Beethoven's reputation as a composer soon became established beyond the limits of his own country, notwithstanding the charges of abstruseness, unpopularity, and the like, which he, like most men of original power, had to submit to from the obtuse arrogance of contemporary criticism. The summit of his fame, so far as it manifested itself in personal honours conferred upon him, was reached in 1815, when Beethoven celebrated by a Symphony the victories of the Allies over the French oppressor, and was rewarded by the applause of the sovereigns of Europe, assembled at the Congress of Vienna.

In the same year he received the freedom of that city, an honour much valued by him. After that time his immediate popularity began to some extent to decline before the ephemeral splendour of the composers of the day; and the great master seemed henceforth to speak more to coming generations than to his ungrateful contemporaries. When, however, on rare occasions he emerged from his solitude, the old spell of his overpowering genius proved to be unbroken. In particular, mention must be made of that memorable *Academië* (concert) in 1824, at which his 9th Symphony, and parts of the grand *Missa Solemnis*, were performed, producing a storm of applause—inaudible, alas! to the composer, who had to be turned round by one of the singers to realize, from the waving of hats and handkerchiefs, the effect of his work on the excited multitude.

The last-mentioned incident leads us to one of the most tragic features of Beethoven's life. By the bitter irony of fate, he who had given to thousands enjoyment and elevation of the heart by the art of sound, was himself deprived of the sense of hearing. The first traces of beginning deafness showed themselves as early as 1797, and were perceived by the master with an anxiety bordering on despair. Physicians and quacks were consulted with eagerness, but all their efforts (partly impaired, it must be confessed, by the unruly disposition of the patient) proved unable to stem the encroaching evil. The Royal Library of Berlin possesses a melancholy collection of ear-trumpets and similar instruments, partly made expressly for Beethoven to assist his weakened sense, but all to no avail. In his latter years conversation with him could be carried on by writing only, and of the charms of his own art he was wholly deprived. But here, again, the victory of mind over matter,—of genius over circumstance,—was evinced in the most triumphant manner. It has been asserted, not without reason, that the euphonious beauty of some of Beethoven's vocal compositions has suffered through his inability to listen to them; but how grand is, on the other hand, the spectacle of an artist deprived of all intercourse with what to him in this world was dearest, and yet pouring forth the lonely aspirations of his soul in works all the more sublime as we seem to hear in them the voice of the innermost spirit of mankind, inaudible to the keen ears of other mortals. If in this manner the isolation of Beethoven further sublimated his efforts as an artist, it, on the other hand, poignantly intensified his sufferings as a man. His was a heart open to the impressions of friendship and love, and, in spite of occasional roughness of utterance, yearning for the responsive affection of his kind. It is deeply touching to read the following words in the master's last will, written during a severe illness in 1802:—"Ye men," Beethoven writes, "who believe or say that I am inimical, rough, or misanthropical, how unjust are you to me in your ignorance of the secret cause of what appears to you in that light. . . . Born with a fiery, lively temper, and susceptible to the enjoyment of society, I have been compelled early to isolate myself and lead a lonely life; whenever I tried to overcome this isolation, oh! how doubly bitter was then the sad experience of my bad hearing, which repelled me again; and yet it was impossible for me to tell people, 'Speak louder, shout, for I am deaf.'"

Domestic troubles and discomforts contributed in a minor degree to darken the shadow cast over our master's life by the misfortune just alluded to. Although by no means insensible to female beauty, and indeed frequently enraptured in his grand, chaste way, with the charms of some lady, Beethoven never married, and was, in consequence, deprived of that feeling of home and comfort which only the unceasing care of refined womanhood can bestow. His helplessness and ignorance of worldly matters

completely exposed him to the ill treatment of servants, frequently, perhaps, excited by his own morbid suspicions and complaints. On one occasion the great master was discovered with his face bleeding from the scratches inflicted by his own valet. It was from amidst such surroundings that Beethoven ascended to the sublime elevation of such works as his *Missa Solemnis* or his 9th Symphony. But his deepest wounds were to be inflicted by dearer and nearer hands than those of brutal domestics. Beethoven had a nephew, rescued by him from vice and misery, and loved with a more than father's affection. His education the master watched with unceasing care. For him he hoarded with anxious parsimony the scanty earnings of his artistic labour. Unfortunately, the young man was unworthy of such love, and at last disgraced his great name by an attempt at suicide, to the deepest grief of his noble guardian and benefactor.

Beethoven died on March 27, 1827, during a terrible thunderstorm. It ought to fill every Englishman's heart with pride that it was given to the London Philharmonic Society to relieve the anxieties of Beethoven's deathbed by a liberal gift, and that almost the last utterances of the dying man were words of thanks to his friends and admirers in this country.

Beethoven's compositions, 138 in number, comprise all the forms of vocal and instrumental music, from the sonata to the symphony,—from the simple song to the opera and oratorio. In each of these forms he displayed the depth of his feeling, the power of his genius; in some of them he reached a greatness never approached by his predecessors or followers. His pianoforte sonatas have brought the technical resources of that instrument to a perfection previously unknown, but they at the same time embody an infinite variety and depth of emotion. His nine symphonies show a continuous climax of development, ascending from the simpler forms of Haydn and Mozart to the colossal dimensions of the *Choral Symphony*, which almost seems to surpass the possibilities of artistic expansion, and the subject of which is humanity itself with its sufferings and ideals. His dramatic works—the opera *Fidelio*, and the overtures to *Egmont* and *Coriolanus*—display depth of pathos and force of dramatic characterization. Even his smallest songs and pianoforte-pieces reflect a heart full of love, and a mind bent on thoughts of eternal things.

Beethoven's career as a composer is generally divided into three periods of gradual progress. We subjoin a list of his most important compositions, grouped according to the principle indicated.

The first period extends to the year 1800. At the beginning we see Beethoven under the influence of his great predecessors, Haydn and Mozart, but progressing in rapid strides towards independence of thought and artistic power. To this time belong Three Trios for Pianoforte and Strings, Op. 1; Sonata for Pianoforte in E flat, Op. 7; Trio for Pianoforte and Strings in B flat, Op. 11; *Sonata Pathétique*; First Concerto for Pianoforte and Orchestra in C, Op. 15; *Adelaide* (composed 1797); also the celebrated *Sextet*, Op. 20, and the First Symphony, Op. 21 (the last two works published in 1800).

The second period, from 1800-1814, marks the climax of formal perfection. The works of this time show the highest efforts of which music, as an independent art is capable. We mention the *Mass* in C, Op. 86; our master's only opera, *Fidelio*, and his overture and incidental music to Goethe's *Egmont*; the Symphonies, Nos. 2-8, amongst which those called the *Pastoral*, the *Eroica*,<sup>1</sup> and those

<sup>1</sup> This symphony was originally written in celebration of Napoleon, at that time consul of the French Republic. When Beethoven heard of his assuming the imperial title, he tore off the dedication and trampled it under foot.

in C minor and A major deserve special mention; Concerto for the Violin, *Op.* 61; Concerti for the Pianoforte, Nos. 3-5; Overtures to *Prometheus*, *Coriolanus*, *Fidelio*, and *King Stephen*; also numerous sonatas for the pianoforte, quartets, quintets, and other pieces of chamber music.

The third period may be described as that of *poetic music*,—a distinct poetic idea becoming the moving principle before which the forms of absolute music have to yield. Beethoven has, by the works belonging to this class, ushered in a new phase of music, as will be further shown in the historical sketch of the art. We name that unequalled master-piece of symphonic art, the Ninth or *Choral Symphony*; the *Mass Solemnis*; the Sonatas for Pianoforte, numbered respectively *Op.* 101, 102, 106, 109, 110, 111; the marvellous Quartets for Strings, *Op.* 127, 130, 132, 135; also the 33 Variations on a Valse by Diabelli, *Op.* 120.

For fuller information on the great master's life and works than our limited space has permitted us to give, we refer the reader to the biographical and critical works of Schindler, Thayer, Nohl, Marx, and Nottbohm. (F. H.)

**BEETLE**, a name commonly applied to those insects which form the order *Coleoptera* ("sheathwinged"), and which are readily distinguished from all others by the nature of the two upper wings. These are formed of a hard, horny substance known as *chitin*; and, although useless in flight, they serve as shields for the protection of the delicate wings underneath, while in many cases their hardness protects the beetle itself from the attacks of insectivorous birds. In some instances the *elytra*, as those upper wings are called, are firmly soldered together, and such species are thus rendered incapable of flight. Owing to the beauty of many of the exotic species, and the ease with which they can be preserved, beetles have been collected with great diligence by entomologists, so that nearly 80,000 species, it is estimated, have already been described. Among the members of so large a group it need hardly be said that the greatest diversity exists in form and habits. They are all, however, provided with a masticatory mouth; and in such predatory species as the Tiger Beetles, the mandibles are largely developed, and often armed with acute teeth. Many of them are carnivorous, feeding on other insects, and on decaying animal matter; but the larger proportion live on the fruits, leaves, and stems of plants, in many instances doing great damage to cereal crops and forest trees. In Germany, in the year 1783, a million and a half of trees are said to have been destroyed in the Harz Forest alone by means of two small species of wood-boring beetles; and in North America at the present time the potato crop is being annually blighted by the devastations of the larvae of what is known as the Potato Beetle (*Doryphora decemlineata*). Beetles undergo complete metamorphosis, passing from the larva to the pupa stage, in which they sometimes remain for several years before emerging as full-formed insects; others, however, undergo all the changes from egg to beetle in a few months. Many of those insects, such as the Goliath and Hercules Beetles, attain gigantic proportions, measuring often 6 inches long, exclusive of antennae, and 2 inches broad; and many bear on the upper surface of their bodies curious horn-like projections. Others, as the Diamond Beetle of Brazil, are adorned with the most brilliant colours, showing a beautiful metallic lustre; and the *elytra* of such species are now largely used by jewellers in the manufacture of personal ornaments. See *COLEOPTERA* and *INSECTA*.

**BEGAS, KARL**, a distinguished German historical painter, was born at Heinsberg in 1794, and died in 1854. His father, a retired judge, destined him for the legal profession, but the boy's tastes pointed definitely in another direction. Even at school he was remarked for his wonderful skill in

drawing and painting, and in 1810 he was permitted to visit Paris in order to perfect himself in his art. He studied for eighteen months in the atelier of Gros, and then began to work independently. In 1814 his copy of the Madonna della Sedra was bought by the king of Prussia, who was attracted by the young artist, and did much to advance him. He was engaged to paint several large Biblical pictures, and in 1825, after his return from Italy, continued to produce paintings which were placed in the churches of Berlin and Potsdam. Some of these were historical pieces, but the majority were representations of Scriptural incidents. Begas was also celebrated as a portrait painter, and supplied to the royal gallery a long series of portraits of eminent Prussian men of letters. At his death he held the post of court painter.

**BEGBAZAAR**, or **BEHRBAZAR**, a town of Asiatic Turkey, in the Anatolian province of Angora, situated on the Sangarius or Sakaria, about 52 miles W. of the provincial capital. Its houses are two stories in height, and roofed with shingles. Carpet-weaving is carried on in the town, and rice, cotton, and fruits are cultivated in the neighbourhood. The pears that are sold in Constantinople as the produce of Angora are really grown by the people of Begbazar. Numerous remains of ancient works in marble are found throughout the town. Population, 4750.

**BEGHARDS** and **BEGUINES**. The nature and history of the Beghards is one of the obscurest problems in mediæval times, and nothing very certain has been ascertained. During the Middle Ages there were formed, alongside of the regular orders, companies of men and women who devoted themselves to a religious life, but did not bind themselves by strict vows. The design was to enable men and women, who did not mean to separate themselves entirely from the world, to lead, nevertheless, what, in the Middle Ages, was esteemed the religious life. Such companies were the Tertiarii of the Dominican and Franciscan orders, and at first the Beghards and Beguines were similarly constituted. The first notices we have of them tell us that, in the end of the 12th century, in several of the towns of the Netherlands, companies of women formed themselves together, under a simple rule, for the purpose of taking care of the sick and for other charitable objects. They were generally widows and maidens of high rank, and were called *Bèghine*, or *Beguine*, or *Beguttas*. The origin of the word is very obscure. Some time later, companies of men were formed in a similar way, and under the same rule. They took no vows, and were at liberty to leave the company when they liked. The men were called *Beghards*. In the 14th century these *Beghards* seem to have attached themselves to the Franciscans, and to have been instrumental in exciting to revolt that portion of the order which rebelled against the Pope. For some period, indeed, the terms *Fratricelli* or *Spirituales* (the two names for the rebel Franciscans) are used synonymously with *Beghards*. It is believed that the Arabian pantheism of Averroes had become diffused among many of the mystical sects, and that societies, originally purely religious, had become partly political. We know, at all events, that, in the 14th century, the *Beghards* were in close alliance with the communistic and pantheistic "Brethren of the Free Spirit." Clement V. denounced them at the Council of Vienna, and launched two bulls against them; and Pope John XXII., while he protected the *Beguines*, persecuted the *Beghards*. Such *Beghards* as still remained were absorbed in the Tertiarii of the Franciscans in the 17th century; but small communities of *Beguines*—*Beguines*, as they are called—still exist in the Netherlands, and in their organization are somewhat similar to many Anglican sisterhoods. (Cf. Moaheim, *De Beghards et Beguinabus*, the book upon the subject,

and Hahn's *Geschichte der Keeser im Mittelalter*. For the meaning of the word see Du Cange, *Gloss.*)

BEHAR, a province of British India, under the jurisdiction of the Lieutenant-Governor of Bengal, situated between 24° and 28° N. lat., and 83° and 89° E. long. It comprises the districts of Champáran, Tirhut, Sháhábád, Sárán, Patná, Furrish, Bhágalpur, and the Santál parganá; and is bounded on the N. by the independent kingdom of Nepal; on the E. by the Rájsháhi and Bardwán divisions of Bengal proper; on the S. by the Chhotá Nágpur division; and on the W. by the North-Western Provinces. The general aspect of the country is flat, except in the district of Monghir, where detached hills occur, and in the south-east of the province, where the Rájmahal and Santál ranges abut upon the plains.

Behar abounds in great rivers, such as the Ganges, with its tributaries, the Ghagrá, Gandak, Kusí, Mahámandá, and Son. The Ganges enters the province near the town of Baxar, flows eastward, and passing the towns of Dinájpur, Patná, Monghir, and Colgong, leaves the province at Rájmahal. It divides the province into two almost equal portions; north of the river lie the districts of Sárán, Champáran, Tirhut, Furrish, and part of Monghir and Bhágalpur, and south of it are Sháhábád, Patná, Gayá, the Santál parganá, and the rest of Monghir and Bhágalpur. The Ganges and its northern tributaries are navigable by country boats of large burden all the year round. The Son (the most important of the southern tributaries) enters the province in the extreme south-west, and forming for a short distance its boundary in that direction, flows north, past Khotágarh and Aráh, separating the districts of Sháhábád from those of Gayá and Patná, and joins the Ganges opposite Cháprá. It has a very wide bed, and pours down its waters with great velocity during the rains. The principal hills within the province are the Moher hill in the district of Gayá, 1620 feet; Santál parganá hills, 800 to 1000 feet, Rájmahal and Monghir hills, 1800 feet; and Rájgarh hill in Patná, 1200 feet above sea-level.

Behar Province contains eight districts, with an area of 42,417 square miles, and a total population in 1872 of 19,726,101 souls, inhabiting 48,285 villages or townships, and 2,252,036 houses; persons per square mile, 465; per village, 409. The males numbered 9,797,649, or 49·6 per cent., and the females, 9,928,452, or 50·4 per cent., of the total population. Of the provincial population, 16,526,250, or 83·7 per cent., were Hindus; 2,626,053, or 13·4 per cent., Mahometans; 54 Buddhists; 2063 Christians; and 565,081, or 2·9 per cent., of unspecified religion, mostly aborigines. Of the male adults, 3,613,231 are returned as agriculturists, and 2,489,557 non-agriculturists. The aboriginal tribes consist of the Bhars, Chersus, Dhángars, Kanjhárs, Kharvárs, Kols, Mala, Náláys, Nats, Paharás, Santáls, and Tharus. The census of 1872 returned 49 towns as containing upwards of 5000 inhabitants, particulars of which will be found in the accounts of the districts within which they are situated. Rice, wheat, barley, pulses, maize, and various kinds of millets, form the principal food-grains of the province. Rice is the main staple of food; but in elevated and dry localities, wheat, maize, millet, and peas are substituted. Potatoes, cabbages, &c., were introduced by Europeans, and are now largely cultivated. Many kinds of fruits and vegetables are also produced. The commercial staples consist of oil-seeds, opium, indigo, sugar, cotton, and saltpetre. Upwards of 800,000 tons of oil-seeds were exported from Behar in 1872. The principal marts for oil-seeds are Bevalganj, in the Sárán district, and Kohrá in Tirhut. The cultivation of opium is a Government monopoly, and no person is allowed to grow the poppy except on account of Government. The Behar Opium Agency has its headquarters at the town of Patná. Annual engagements are entered into by the cultivators, under a system of pecuniary advances, to sow a certain quantity of land with poppy, and the whole produce in the form of opium is delivered to Government at a fixed rate. The area under poppy cultivation in the Behar Agency in 1872 amounted to 320,925 acres. The Behar indigo, generally called Tirhut indigo, yields about one-half of the total produce of that dye which is annually exported from Calcutta. In the Bhágalpur division there are 44 factories, yielding on an average about 800 tons of indigo a year. In the Patná division, indigo cultivation is almost entirely confined to the north of the Ganges, in the districts of Tirhut, Sárán, and Champáran, which in 1872 contained 104 factories, including outworks, and yielded 1958 tons of the dye. The indigo industry is almost entirely conducted by Europeans, and the total capital invested in the business in Behar is estimated at upwards of a million sterling. Large quantities of sugar are exported, but the cotton grown in the province is not sufficient for the requirements of the people, and has to be supplemented by imports of raw cotton and English piece goods. Saltpetre is largely refined in Tirhut, Sárán, and Champáran, and is exported both by rail and river to Calcutta; the quantity

exported by river in 1872 being 22,749 tons. The manufactures of less importance are teas-silk, paper, blankets, brass utensils, fire-arms, carpets, coarse cutlery and hardware, leather, ornaments of gold and silver, &c. Of minerals—lead, silver, and copper exist in the Bhágalpur division, but the mines are not worked. One coal-mine is worked in the Santál parganá. Before the construction of railways in India, the Ganges and the Grand Trunk road afforded the sole means of communication from Calcutta to the North-Western Provinces. But now the railroad is the great highway which connects Upper India with Lower Bengal. The East Indian Railway runs throughout the length of the province; total length of rail, upwards of 500 miles. Besides the Grand Trunk road, the other important roads in the province are—(1), Road from Synthia Railway Station to Bhágalpur; (2), Darjiling road, from Kárágola to Siliguri; (3), from Shahrgháti on the Grand Trunk road to Patná city, and thence to Tirhut town. There are also many local roads under the management of the district road committees. The gross revenue of the province in 1872 amounted to £1,596,952, of which £1,184,906, or 74 per cent., was from land. In 1872 the 8 districts of the province were divided into 37 executive subdivisions, and contained 52 civil judges and 80 magistrates. The total police force (regular, municipal, and village) consists of 60,228 men; cost, £210,943. In 1872 there were 215 Government and aided schools, attended by 9454 pupils, and maintained at a total cost of £17,835, of which Government contributed £10,328. These are exclusive of unaided schools. The census of 1872 returned the total number of schools, aided and unaided, in the province at 4781. Bengali is the language in the eastern part of the province; but Hindi, one of the dialects of Sanskrit, is the language of the rest. The Mahometan population use Hindustáni or Urdu, a language of modern origin, formed from the fusion of Persian and Arabic with Hindi. The climate of Behar is very hot from the middle of March to the end of June, when the rains set in, which continue till the end of September. The cold season, from October to the first half of March, is the pleasantest time of the year. The total rainfall in 1872 varied from 32 to 60 inches in different localities; minimum temperature in December, 53°; maximum in May, 105°.

In ancient times Behar comprised the dominions of the kings of Magadha, who at one time were the lords paramount of India, and whose court is represented as one of the most brilliant that ever existed. Alexander the Great when he invaded India intended to push his conquests to Palibothra, the capital of Magadha, whose monarch he heard could oppose him with 30,000 cavalry, 600,000 infantry, and 9000 elephants. Their highest point of grandeur was supposed to have been attained at the time of Seleucus Nicator, one of the immediate successors of Alexander, who invaded Magadha. According to the Greek historians he was victorious, but this is doubtful, as he relinquished all the Macedonian conquests to the east of the Indus, and gave his daughter in marriage to Chandra Gupta, the reigning king. At this time Magasthenes was appointed to represent him at Magadha court. The Magadha monarchs encouraged arts and learning, constructed roads, and sent their fleets across the Bay of Bengal to colonise Java, Bali, and other islands in the Indian Archipelago. The Magadha kingdom flourished from the 4th century before the Christian era to the 5th century after it. But ancient Behar is far more celebrated in another respect. Six centuries before the Christian era it was the cradle of Buddhism when that religion was in its infant state. It sent its missionaries to Ceylon, China, Thibet, and Tartary, and the religion they taught is still followed by 300 millions of people. Behar is a sacred spot in the eyes of the Chinese and other Buddhist nations. In 1202 A.D. Behar fell into the hands of the Mahometans without a struggle, and from this time it formed one of the three subahs or provinces under the rulers of Bengal. In the time of Akbar it comprised the seven *sarkárs* of Monghir, Champáran, Hajipur, Sárán, Tirhut, Rohtás, and Behar. It came into the possession of the East India Company with the acquisition of the Dáwaní in 1765, when the province was united with Bengal. In 1857 two zamindárs, Umar Singh and Kumár Singh, rebelled against the British Government, and for some months held the ruinous fort of Rohtás against the English.

BEHAR, a magisterial subdivision, and a town of Patna district. The SUBDIVISION was formed in 1846. It has



an area of 792 square miles, with a total population of 570,888 souls, the average population per square mile being 721. **BEHAR TOWN** is situated in 25° 10' N. lat., and 85° 35' E. long. It was formerly the capital of a subah or governorship under the Mahometans, but at present it is merely a subdivisional town. Population in 1872:—Hindus, 31,006; Mahometans, 13,282; others, 7; total, 44,295. Municipal income, £1100; expenditure, £1120; rate of taxation, 6d. per head of population.

**BEHBEHAN**, a town of Persia, in the province of Fars, pleasantly situated in the middle of a highly-cultivated plain, which is watered by the Rivers Zab and Jerahi. The walls are about three miles in circumference; and there is a castle called Kalah Naranj, or Orange Castle, in the S.E. corner. The population is variously estimated at 10,000 and at 4000, the latter more probably correct, as the place has suffered from plague and oppression.

**BEHEM**, or **BEHAIM**, **MARTIN**, a well-known navigator and cartographer, was born at Nuremberg about 1436. Having entered the service of Portugal, he was appointed, in 1484, to act as geographer in the expedition of Diego Cam to the western coast of Africa, and on his return to Lisbon received the honour of knighthood in reward for his services. He was afterwards employed by the king in various capacities, and visited the capital from time to time in connection with his engagements; but, after his marriage in 1486, his principal residence seems to have been at Fayal, in the Azores, where his father-in-law, Job Hueter, held the rank of governor of the Flemish colony. On a visit to his native city in 1492, he constructed a terrestrial globe, in which he incorporated the discoveries of Marco Polo and other recent travellers. The globe is still preserved in the family, and has frequently been reproduced by engraving. (See Doppelmayr, *Hist. Nachricht v. Nürnberg. Mathem. u. Künstler*, 1730; Pigafetta, *Prem. voy. autour du Monde*, 1802; and atlas to Vivien de Saint Martin's *Hist. de la Geog.*, 1874.) Behem's scientific attainments have been very variously estimated,—some placing him in the very first rank among the geographers of his time, while others maintain that he hardly reached the level of the ordinary Portuguese chart-makers. Blunders of 16 degrees are found on his globe in the localization of places which he himself visited, while in the contemporaneous maps errors of more than one degree were comparatively rare. It is generally agreed that he had no share in Transatlantic discovery, and though Columbus and he were in Portugal at the same time, no connection between the two has been established. He died at Lisbon in 1506, or, according to his tombstone, 1507.

See Murr, *Diplomat. Gesch. des berühmten Ritters Behaim*, 1778; Humboldt, *Krit. Untersuchungen*, 1836; Ghillany, *Gesch. des Seefahrers M. Behaim*, 1853; Lelewel, *Geog. du moyen Age*, 1857; Petermann's *Mittheil.*, 1858; Peschel, *Zeitalter der Entdeckungen*, and *Gesch. der Erdkunde*, 1865; Breusing, *Zur Gesch. der Geogr.*, 1869.

**BEHISTUN**, **BISUTUN**, or **BISUTUN**, the ancient Baghistan (*Alvns Bagistanus*), a precipitous mountain or rock in Persia, remarkable for the extensive inscriptions of a very early date still preserved on some parts of its escarpment. It lies 27 miles E. of Kirmanshah, in the province of Irak Ajemi. The principal inscription is cuneiform, and relates to the victories of Darius Hystaspes, who is represented in a sculptured centre-piece as receiving the homage of a number of captives, upon one of whom he has planted his foot. The labour expended on the work must have been very great. The surface of the rock has been carefully smoothed, and pieces have had every crevice or hollow filled up with lead; the accuracy and regularity of the characters is almost unexampled, and the whole of the tablets have been carefully coated with a siliceous varnish to preserve them from the weather. Of the other

inscriptions the first is in Greek and the second in Arabic, but neither is of any great importance. It was not till 1846 that the Darius tablets were translated by Sir Henry Rawlinson, who has given a complete account of his labours in the *Journ. Roy. As. Soc.* The principal notice of Behistun in the Greek or Roman writers is that of Diodorus Siculus, who tells how Semiramis visited the place on her march from Babylon to Ecbatana, and caused her own image to be sculptured on the rock. He interprets the name of the mountain by *Διὸς ὄρος*, the Hill of Jove, which is not very different from that proposed by modern scholars—"the dwelling of the gods." (See *Journ. R. Geog. Soc.*, 1839; *Journ. Roy. As. Soc.*, vol. x and xii.; Ker Porter's *Travels*; Benfey's *Keilinschriften*, 1847.)

**BEHMEN**, **JACOB**. See **BOEHME**.

**BEHN**, **APHRA**, an English authoress of some celebrity, was born of a good family in Canterbury in the reign of Charles I., probably in 1642. Her father, whose name was Johnson, having received the appointment of Lieutenant-general of Surinam, proceeded to the West Indies, taking with him his whole family. Mr Johnson died on the voyage; but his family reached Surinam, and resided there for some years. Here Aphra learned the history, and acquired a personal knowledge, of the American prince Oroonoco and his beloved Imoinda, whose adventures she has related in her novel *Oroonoco*. On her return to London she is said to have married Mr Behn, a merchant of Dutch extraction residing in that city, of whom nothing but the name has ever been known, if anything more even existed. The wit and abilities of Mrs Behn brought her into high estimation at court, and Charles II. employed her to transact some affairs of importance abroad during the Dutch war. For this purpose she went to Antwerp, where she skilfully contrived to penetrate so far into the secrets of state as to accomplish the objects of her mission; and in the latter end of 1666, by means of the influence she had gained over one Van der Albert, she wormed out of him the design formed by De Ruyter, in conjunction with the family of the De Witts, of sailing up the Thames and burning the English ships in their harbours. This she communicated to the English court, but although the event proved her intelligence to have been well founded, it was at the time disregarded,—which circumstance, together with the disinclination shown to reward her for her services, determined her to drop all further thoughts of political affairs. She returned to England, and had a narrow escape on the voyage home, the vessel in which she sailed having foundered. From this period she appears to have supported herself by her writings. Her works are numerous, and all of them are of a lively and amatory character. Her dramas are sometimes well constructed, but they are among the worst specimens of the later Stuart literature. Of her short tales, or novelettes, the only one possessing any merit is the story of *Oroonoco*, which was made the basis of Southerne's most popular tragedy. Mrs Behn died on the 16th of April 1689, and was interred in the cloisters of Westminster Abbey. Her works have passed through many editions, the latest being that published by Pearson, 1872.

**BEHRING'S ISLAND**, the most westerly of the Aleutian group in the North Pacific, in 55° 22' N. lat., 166° E. long. It is rocky and desolate, and is only remarkable as being the place where the navigator Behring was wrecked and died in 1741. Population 2500.

**BEHRING'S STRAIT**, the narrow sea between the N.E. part of Asia and the N.W. part of North America, connecting the North Pacific with the Arctic Ocean. At the narrowest part, East Cape in Asia approaches within about 36 miles of Cape Prince of Wales on the American shore. The former is in 66° 6' N. lat., 169° 38' W. long.; and the latter in 65° 46' N. lat., 168° 15' W. long. North

and south of these points the coasts on both sides rapidly diverge. They are steep and rocky, and considerably indented. The Asiatic coast, extending from Cape Serday to Cape Chukotsky, a distance of about 400 miles, presents several large and commodious bays. The strait is in general from 23 to 30 fathoms in depth, and contains a few small islands known as the Diomedea Islands. Haze and fogs greatly prevail, and the temperature is low. The strait derives its name from Vitus Bering or Behring, a German in the Russian service, who discovered it in the year 1728. It was subsequently explored and described with great accuracy by Captain Cook, in 1788. (See *Arctic Papers for Expedition of 1875*.)

BEIRA, a province of Portugal, bounded on the N. by the provinces of Trax-os-Montes and Minho, E. by Spain, S. by Alemtejo and Portuguese Estremadura, and W. by the Atlantic. Area about 8586 square miles. Population in 1871, 1,294,282. It is administratively divided into the districts of Aveiro, Coimbra, Vizeu, Guarda, and Castello Branco, while it is popularly regarded as consisting of the three sections of *Beira-Alta* or Upper Beira, *Beira-Baixa*, or Lower Beira, and *Beira-Mar*, or Maritime Beira. Except along the coast, the surface is for the most part mountainous,—the highest point, in the Serra de Estrella, being 7524 feet. Besides the Douro, which is far the largest, the Aguada, the Mondego, the Vouge, and the Zesere are the principal rivers. The soil, except in the valleys, is dry and rocky, and large stretches are covered with heath. The principal agricultural productions are maize, wheat, garden vegetables, and fruit. The olive is largely cultivated, the oil forming one of the chief articles of export; and good wine is also produced. In the flat country between Coimbra and Aveiro the marshy land is laid out in rice-fields, or in pastures for herds of cattle and horses. The rearing of sheep is not so well attended to as formerly, except in Upper Beira. In the neighbourhood of Lamego swine are reared in considerable numbers, and furnish the well-known Lisbon hams. There is comparatively little manufacturing industry in the province, with the exception of the production of woollen cloth, which occupies a large part of the population in the district of Castello Branco or Covilhao. Silver and lead ores exist in the mountains, but are neglected. Iron, coal, and marble are worked to some extent, and millstones are quarried in some places. Salt is obtained in considerable quantities from the lagoons along the coast. There is a striking difference of character between the inhabitants of the lower and more elevated regions of Beira, the former being sociable and courteous, if also indolent and lax in morals; while the latter are grave and reserved, hardy and industrious. The principal towns in the province are Coimbra, Vizeu, Aveiro, Omar, and Lamego. The heir-apparent to the throne of Portugal has the title of Prince of Beira.

BEIT EL FAKIH (i.e., *House of the Saint*), an un-walled town in Arabia, in the province of Yemen, 77 miles N.E. of Mocha, and about 17 from the coast, in 43° 23' E. long., 13° 32' N. lat. It is situated on a barren, sandy plain, protected against the predatory incursions of the Arabs by a castle, in which the governor resides. It was founded in the 17th century by the inhabitants of the seaboard town of Alafaka, who were led to seek a new settlement from their once famous harbour being rendered useless by coral banks; and it soon became the greatest seat of the coffee-trade in the world. The prosperity of the city was considerably diminished under the Wahabees and Mehemet Ali of Egypt, though even during his domination it is stated to have had 30,000 inhabitants. It is still engaged in the coffee-trade, and also deals in incense, gum, and pearls. Most of the common houses are mere grass-roofed huts, but here and there are ancient stone

buildings. The most remarkable of these is the mosque of Akhmed-Ibn-Musa, which is older than the city itself. The principal ports at which the exports are shipped are Lohaya, about 32 miles N.W., and Hodeida, 37 miles S. Population, 8000.

BEJA, a city of the province of Alemtejo, in Portugal, 36 miles S. of Evora. It is surrounded with walls, is the see of a bishop, and contains about 6600 inhabitants, who are for the most part occupied in cultivation, and especially in breeding cattle.

BEJAR, a fortified town of Spain, in the province of Salamanca, situated on the River Cuerpo de Hombra, in a deep and fertile valley of the Sierra de Bejar, about 45 miles S. of the provincial capital. Its streets are narrow, but well paved, and most of the houses are old. The manufacture of cloth is carried on, and there is a considerable trade in cattle at the annual fair. There are saline springs, with a temperature of 104° to 108° F. A ducal family takes its title from the city, and has a palace within its walls. Population, 10,683.

BEKE, CHARLES TILSTON, a distinguished English traveller, geographer, and Biblical critic, was born in London, October 10, 1800. Educated for the pursuits of commerce, he afterwards studied law for a short time at Lincoln's Inn, but finally devoted himself to the study of historical, geographical, and ethnographical subjects. The first-fruits of his researches appeared in his work entitled *Origines Biblicæ, or Researches in Primæval History*, which was published in 1834. As an attempt to reconstruct the early history of the human race from geological dates, it naturally raised a storm of opposition on the part of those who felt it their duty to defend the traditional readings of the book of Genesis. For about two years (1836 to 1838) Dr Beke held the post of British Consul in Saxony. From that time till his death his attention was devoted to geographical studies, chiefly of Africa and the Nile Valley. Aided by private friends, he visited Abyssinia in connection with the political mission under Major Harris, and explored districts which up to that time had remained unknown to Europeans. The valuable results of this journey, which occupied him from 1840 to 1843, he gave to the world in 1845 in the work entitled *Abyssinia, a Statement of Facts*, &c. Once again, after an interval of more than twenty years, he went to Abyssinia, for the purpose of obtaining from King Theodore the release of Mr Rassam and other British captives. In this he succeeded, but the king afterwards changed his mind and continued to detain the prisoners. In 1848 he made an unsuccessful attempt to explore the Upper Nile; his labour was repaid, however, by a large amount of information about the countries which he traversed. The ardour with which he pursued his chosen path was shown by his undertaking in his seventy-fourth year a journey to Palestine, for the purpose of determining the real position of Mount Sinai. He conceived that it was on the eastern side of the Gulf of Akabah; and his exploration convinced him that his view was right. It has not, however, commended itself to general acceptance. Dr Beke died at Bromley, in Kent, July 31, 1874.

Dr Beke's writings are very numerous. Among the more important, besides those already named, are—*An Essay on the Nile and its Tributaries*, 1847; *On the Sources of the Nile*, 1849; and *The British Captives in Abyssinia*, 1848. He contributed a large number of *Memoirs and Papers* to the Royal Geographical Society, the British Association, the Philological Society, the *Athenæum*, the *Archæologia*, the *Edinburgh New Philosophical Journal*, &c., &c. He was a fellow of the Royal Geographical Society, and for his contributions to our knowledge of Abyssinia received its gold medal, and also that of the Geographical Society of France. For his *Origines Biblicæ* the degree of Ph.D. was conferred on him by the University of Tübingen. He was also a fellow of the Society of Antiquaries. In 1870 he received the grant of a pension on the civil list.

**BÉKÉS**, a market-town of Hungary, formerly a royal free city, and the capital of the county of the same name, situated at the confluence of the White and Black Körös, 14 miles N.N.W. of Gyula, which is now the capital. The inhabitants, principally Calvinists, amount to 22,500, and are chiefly engaged in agriculture and the rearing of cattle. Count Wenkheim has a fine castle in the town, which was at one time strongly fortified. Long. 20° 41' 37" E., lat. 46° 46' 16" N.

**BEKKER, BALTHAZAR**, a celebrated Dutch divine, was born in Friesland in 1634. He was the author of several works in philosophy and theology, which from their freedom of thought and critical rationalism excited considerable enmity against him. His most celebrated production was the work entitled *Die Betooverde Wereld*, or *The World Bewitched*, in which he examined critically the phenomena generally ascribed to spiritual agency, and exposed with much force the many absurdities regarding the power of Satan that had become articles of Christian faith. The *odium theologium* was fiercely roused by this book, and Bekker was deposed from the office of the ministry. He resided at Amsterdam till his death in 1698.

**BEKKER, OF WOLFF, ELIZABETH**, a Dutch novelist, was born in 1738. She was married to Adrian Wolff, a Reformed clergyman, but is always known under her maiden name. After the death of her husband in 1777, she resided for some time in France, with her close friend, Agatha Deken. She was exposed to some of the dangers of the French Revolution, and, it is said, escaped the guillotine only by her great presence of mind. In 1795 she returned to Holland, and resided at the Hague till her death in 1804. Her novels were written in conjunction with Agatha Deken, and it is somewhat difficult to determine the exact qualities contributed by each. The *Historie van William Levend* (1785), *Historie van Sara Burgerhart* (1790), *Abraham Blankaart* (1787), *Cornelis Wildschut* (1793-96), have been extremely popular. Some of them have been translated into German and French.

**BEKKER, IMMANUEL**, a distinguished philologist, was born at Berlin in 1785, and died 7th June 1871. He completed his classical education at the university of Halle under the famous F. A. Wolf, who was accustomed to speak of him as his most promising pupil. In 1810 he was appointed to a professorship in the university of Berlin. For several years, between 1810 and 1821, he travelled in France, Italy, England, and parts of Germany, examining classical manuscripts and gathering materials for his great editorial labours. Some detached fruits of his researches were given in the *Anecdota Græca*, 3 vols., 1814-21; but the full result of his unwearied industry and ability is to be found in the enormous array of classical works edited by him. The most famous are *Plato*, 10 vols., 1814-21; *Oratores Attici*, 7 vols., 1823; *Aristoteles* (the Berlin edition), 4 vols., 1831-36; *Thucydides*, 3 vols., 1821; *Aristophanes*, 3 vols., 1825; *Sextus Empiricus*, 1842. He also edited 24 volumes of the Byzantine historians. Bekker confined himself entirely to textual recension and criticism, and contributed little to the extension of general scholarship. He was well read in the old French literature, particularly that of Provence, and contributed many papers on it to the *Memoirs of the Berlin Academy*.

**BEL.** See **BAAL**.

**BEL, OR BELIUS, MATTHIAS**, an Hungarian divine and historian, was born in 1684, and was educated partly at Halle. In 1719 he was made rector of the evangelical Lyceum at Presburg, where he remained till his death in 1749. His great work was the *History of Hungary* (*Notitia Hungariae nova historico-geographica*), 4 vols., 1735-42, which was not completed. Other works devoted to the

history of his native country are—*Hungaria antiqua et nova prodromus*, 1723; *Adparatus ad Historiam Hungariam*, 1735-46. He also wrote on the literature of the Hungarians.

**BEL AND THE DRAGON**, one of the apocryphal books of the Old Testament. See **APOCRYPHA**.

**BELA, OR BELYA**, a town of Baluchistan, capital of the province of Lus, on the north-eastern bank of the River Poorally, 293 miles N. of Khelat. Long. 66° 4' E., lat. 26° 1' N. About one-third of the town in the western quarter is encompassed by a mud wall. The streets are narrow; but from the elevated situation of the town, and its rocky site, they are always clean, even in wet weather. The bazaar is very neat. The governor's residence is surrounded by a castellated mud-wall, which also encloses a dome-covered mosque. Population about 5000.

**BELBEIS, OR BUKARRA**, a town of Upper Egypt, in the province of Kalyubieh, on the eastern arm of the Nile, 28 miles N.N.E. of Cairo. It was formerly considered the bulwark of the kingdom on that side, and was defended by strong fortifications, but these were suffered to fall into decay till 1798, when Napoleon ordered them to be put in repair. In 1163-4 it was besieged for three months by the Crusaders under Amalric, who at length, in 1168, captured and pillaged it. The present population is not supposed to exceed 5000.

**BELEM**, a town of Portugal, now regarded as a suburb of Lisbon. See **LISSBON**.

**BELFAST**, the chief manufacturing and commercial town of Ireland, a municipal and parliamentary borough, the capital of Ulster, and, since 1850, the county town of Antrim, in which, with the exception of the large suburb of Ballymacarret on the other side of the river, it is

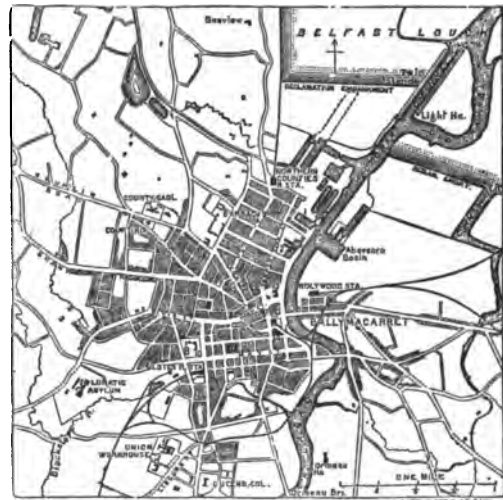

- |                    |                            |                       |
|--------------------|----------------------------|-----------------------|
| 1. Prince's Dock.  | 6. St Ann's Church.        | 11. Linen Hall.       |
| 2. Clarence Dock.  | 7. St George's Church.     | 12. Commercial Bldg.  |
| 3. Queen's Bridge. | 8. Christ Church.          | 13. Custom House.     |
| 4. Albert Bridge.  | 9. St Malach's Cathed.     | 14. Town-Hall.        |
| 5. Trinity Church. | 10. Assemedical Institute. | 15. Central Rail Sta. |

mainly comprised. It is situated in lat. 54° 36' 8.5" N., and long. 5° 55' 53.7" W., at the mouth of the Lagan, which flows into Belfast Lough (Carrickfergus Bay), and is built on an alluvial deposit and land reclaimed from the sea, the greater portion of which is not more than 6 feet above high-water mark. It was thus for a long period exposed to occasional inundations, and was somewhat subject to epidemics; but its situation, improved by drainage, has become more healthy, while the environs are agreeable and picturesque.

The stymology of the name and the origin of the town are equally uncertain, and there is not a single monument of antiquarian interest upon which to found a conjecture. About the beginning of the 16th century Belfast is described as a "town and fortress," but it was in reality a mere fishing-village in the hands of the house of O'Neil. This sept had all along been opposed to the English, and had forfeited every baronial right; but in 1552 Hugh O'Neil of Clandeboyne promised allegiance to the reigning monarch, and obtained the castle of Carrickfergus, the town and fortress of Belfast, and all the surrounding lands. His turbulent successors having been routed by the English, the town and fortress fell into the hands of Sir Thomas Smyth, a favourite of Queen Elizabeth, but were afterwards forfeited by him to the Lord-Deputy Sir Arthur Chichester, who, in 1612, was created Baron Chichester. At this time the town consisted of about 120 houses, mostly built of mud and covered with thatch, while the castle, a two-storied building, was roofed with shingles. In 1632 Thomas Wentworth, Earl Stafford, was appointed first lord-deputy of Ireland, and Belfast soon shared largely in the benefits of his enlightened policy, receiving, among other favours, certain fiscal rights which his lordship had purchased from the corporation of Carrickfergus. Two years after the rebellion of 1641 a rampart was raised round the town, pierced by four gates on the land side. In 1662, as appears by a map still extant, there were 150 houses within the wall, forming five streets and as many lanes; and the upland districts around were one dense forest of giant oaks and sycamores, yielding an unending supply of timber to the woodmen of Carrickfergus.

Throughout the succeeding fifty years the progress of Belfast surpassed that of most other towns in Ireland. Its merchants, in 1686, owned forty ships, of a total carrying power of 3300 tons, and the customs collected were close upon £20,000. When King William arrived at Belfast in 1690 there were only two places of worship in the town, the old corporation church in the High Street, and the Presbyterian meeting-house in Rosemary Lane,—the Roman Catholics not being permitted to build their chapels within the walls of corporate towns.

At the commencement of the 18th century Belfast had become known as a place of considerable trade, and what was then thought a handsome, thriving, and well-peopled town, with many new houses and good shops. During the civil commotions which so long afflicted the country, it suffered less than most other places; and it soon afterwards attained the rank of the "greatest town for trade in the north of Ireland." James Blow and Co. introduced letterpress printing in 1696, and in 1704 issued the first copy of the Bible produced in the island. In September 1737, Henry and Robert Joy started the *Belfast News Letter*, which not only still maintains its existence, but has long been at the head of the Irish Conservative press. Twenty years afterwards the town contained 1800 houses and 8549 inhabitants, 556 of the latter being members of the Church of Rome. It was not, however, till 1789 that Belfast obtained the regular communication, which towns of less importance already enjoyed, with Dublin by stage coach,—a fact which is to be explained by the badness of the roads and the steepness of the hills between Newry and Belfast.

The increased freedom of trade with which Ireland was favoured, the introduction of the cotton manufacture by Robert Joy in 1777, the establishment in 1791 of ship-building on an extensive scale by William Ritchie, an energetic Scotchman, combined with the rope and canvas manufacture already existing, supplied the inhabitants with employment, and increased the demand for skilled labour. The population now made rapid strides as well by ordinary

extension as by immigration from the rural districts. At the close of last century there were about 20,000 inhabitants in the borough, and this total had risen in 1821 to 37,277, in 1831 to 53,287, in 1841 to 70,447, in 1851 to 87,062, in 1861 to 121,602, and in 1871 to 174,412—males 79,815, and females 94,597. In 1875 the population is estimated at 200,000. At the last census the following were the religious professions of the population, viz., Presbyterian, 60,249; Catholic, 55,678; Episcopal, 46,423; Methodist, 6775; Unitarian, 1498; and various, 3892. The number of persons who could read and write at the same date was 95,986; who could read, only 71,700; and who were illiterate, 46,726, or about 27 per cent. of the whole. The number of houses in 1871 amounted to 29,918, viz., inhabited, 27,961; uninhabited, 1761; and building 196.

Belfast Lough is exceedingly picturesque, whether entered by the Antrim or by the Down side of the channel. The outer harbour is one of the safest in the kingdom, great improvements having been made within the last thirty years on the more immediate entrance to the port. The course of the Lagan, which runs past the quays and down to Gramoyle, was originally most tortuous and somewhat difficult to navigate; but, about 1840, the late William Dargan was employed to make a straight cut from the lower part of the harbour and to deepen the channel, so that ships of large draught can be brought to the quays, which extend for about a mile below Queen's Bridge on both sides of the river. There are also seven extensive docks and tidal basins supplied with the necessary conveniences for the shipping. The following table of vessels entered inwards shows the increase of shipping frequenting the port:—

Year.	No. of Vessels.	Tonnage.	Year.	No. of Vessels.	Tonnage.
1728	870	9,180	1845	3655	445,537
1736	770	8,287	1855	5211	768,505
1805	840	64,585	1861	6787	902,578
1825	2069	183,441	1871	8213	1,223,821
1835	2950	290,769	1873	8417	1,397,407

The exports from Belfast being largely conveyed by steamer to London, Liverpool, and Glasgow, and thence trans-shipped to their destinations, do not appear in the Board of Trade returns, as only the direct business with foreign countries, which does not reach any considerable amount, is registered in those tables. Thus other ports get credit for business which really belongs to Belfast. The best illustration of this is afforded by the Board of Trade returns for 1858. Belfast is there stated to have exported goods that year to the amount of £9,344, while the actual sum was £8,569,504. In 1810 the total value of exports was £2,904,820, and in 1835 £4,341,791; in 1852 the amount was £6,573,198, and for 1866 it ran up to £11,915,000. For some years past no official data have been published on this subject, but it may be safely estimated that the gross value of the exports from Belfast exceeds £20,000,000 annually.

The amount of customs and excise collected at the port in 1762 was £32,900, and in 1810 the sum was £428,174. As trade increased with London and Liverpool, a large share of the duties on goods disposed of in Belfast was paid to the merchants of those ports. In 1821 the customs amounted to £306,243, and in 1848 to £376,767. The customs paid in Belfast in 1851 reached £369,415, which, added to that paid in London and Liverpool (£184,750), made a total of £554,165. During the year 1874 the duty paid in Belfast on tea, wine, spirits, and tobacco, amounted to £1,215,191.

For nearly a century past the flax manufacture of Ulster

has been gradually concentrating itself in Belfast. The introduction there in 1830, by T. and A. Mulholland, of machinery for the spinning of linen yarn, was followed by a rapid extension of the industry, and in 1841 there were 240,000 spindles at work. The succeeding ten years showed still greater increase. In 1851 there were 561,000 spindles in operation throughout Ireland, 630,000 in 1861, and 903,000 in 1871, of which about four-fifths had been set up in Belfast. Linen yarns from Belfast form a considerable item in the total export of manufactures. For some time after the trade was started, the average annual export was only about 1,000,000 lb weight; but in 1850 five times that quantity was despatched; in 1862, 15,685,600 lb, and in 1864, 24,075,520 lb.

The weaving of linen by means of power-looms, though long carried on in Dundee, Leeds, and other great seats of manufacture, is of comparatively recent introduction into Belfast,—being hardly known there five-and-twenty years ago. In 1859, however, there were 3000 looms engaged; in 1866 there were 10,500, and that number has now (1875) increased to about 12,500. A number of these have been fitted up for the damask trade, but the great proportion are used for plain linens, “sets” of which of great fineness are worked. The extent of the linen trade may be indicated by the number of persons employed, which amounted in 1871 to 8507, or about 5 per cent. of the population.

Cotton-spinning, which at one period formed a most extensive industry in Belfast, has greatly fallen off,—nearly all the mills having been converted to the spinning of flax.

The enterprise of the citizens of Belfast was well supported by the liberal system of tenure for building purposes granted by the late Lord Donegall and his predecessors. Sites for mills, factories, and other public works were obtained on very reasonable terms, and for all religious and charitable objects those lords of the soil bestowed ground free of rent. In 1851 the places of worship in Belfast open for service belonged—11 to the Episcopalians, 21 to Presbyterians, 8 to Wesleyans, and 4 to Roman Catholics. Since then there has been a large increase in the number; and there are now 19 Episcopal churches, 28 Presbyterian, 16 Wesleyan Methodist, 6 Roman Catholic, 3 Unitarian, and 7 or 8 belonging to various other sects.

The River Lagan is crossed by three bridges, of which the principal is the Queen's Bridge, opened in January 1843, and built on the site of the Old Long Bridge, which dated from 1686. Like most modern towns which have rapidly risen through commerce and manufactures, Belfast cannot boast of many architectural beauties. It would seem as if its people had been too deeply absorbed in the bustle of business to think of æsthetic superfluities. More recently, however, a higher style of building has been adopted; and some of the warehouses and shops show great taste in design and finish of workmanship.

The public buildings most worthy of notice are the White and Brown Linen Halls, the Corn Exchange, the Commercial Buildings, the Museum, the Albert memorial monument, the Northern, Belfast, Ulster, and Provincial Banks, the new theatre, the town-hall, and the range of buildings containing the offices for the customs, the inland revenue, and the postal departments. The county lunatic asylum is in the suburbs of the town; and in the neighbourhood of Queen's College there is an extensive and well-kept botanic garden.

The chief educational establishments are the Royal Academical Institution, the Queen's College (built of brick in the Tudor style and opened in 1849), the Government School of Design, the General Assembly's College, the Catholic Institute, and the Wesleyan Institute; and altogether, in proportion to its extent, no town in the king-

dom is better supplied with educational appliances than Belfast.

Belfast is governed by a corporation of 40 members—a mayor, 10 aldermen, and 29 councillors; and all matters connected with the docks and shipping are under the harbour commissioners, an important body elected by the ratepayers. The borough returns two members to parliament, and the county assises are held there, as well as the quarter sessions, recorder's court, and petty sessions.

BELFORT, *Belfort*, or *Belfort*, a second-class fortified town of France, was formerly in the department of Upper Rhine, and capital of an *arrondissement*; but since the peace of 1871, it has given name to a separate territory not as yet incorporated with any department. It is situated on the left bank of the *Sauvoureuse*, 38 miles S.S.W. of Colmar, at the intersection of several important roads and railways, by which it maintains a considerable trade with Germany and Switzerland. It contains a handsome church,—*St Christophe*, erected in the 18th century,—a college, a large public library, a synagogue, a theatre, and an hospital. There are several iron foundries, and iron-wire and tin-plate factories; and the manufacture of hats and leather is also carried on. Belfort, however, derives its chief importance from the citadel and entrenched camp, which render it one of the most valuable military posts on the French frontier, defending as they do the entrance into the country through the opening between the *Vooges* and the *Jura*. The citadel dates from the 13th century, and the town itself was first regularly fortified in 1688 by *Vauban*. In November 1870 siege was laid to the place by the German forces, but the French garrison managed to hold out till the 16th of February 1871, when they capitulated with the sanction of the Government, and marched out with the honours of war. The conquerors finally evacuated the place in July 1871. At the census of 1872 the population of the town was found to be 8014.

BELGAM [BELGAUM], a district of British India in the Bombay Presidency, extending from 15° 30' to 16° 15' N. lat., and 74° to 76° 30' E. long. It is bounded on the N. by the state of *Miraj*, on the N.E. by the *Baldgi* collectorate, on the E. by the states of *Jámkhandi* and *Mudhol*, on the S. by the collectorates of *Dhárwar* and *Kánar*, on the S.W. by the Portuguese territory of *Goa*, and on the W. by the states of *Sáwantvári* and *Kolhápúr*. The principal rivers, none of which are navigable, are the *Krishná*, flowing through the northern; the *Ghátaprabhá*, through the centre; and the *Máláprabhá*, through the southern portion of the collectorate. To the N. and E. the country is open and well cultivated, but to the S. it is intersected by spurs of the *Sahyádrí* range, thickly covered in some places with forest. Area, 4591 square miles. Population, 938,750 souls, or 204 to the square mile; 57 per cent. Hindus, 7·5 per cent. Mahometans, 5 per cent. Buddhists, ·5 Christians, and ·01 Parsis. *Maráthi* and *Kanarese* are both spoken, the former chiefly in the W. and S. of the district, and the latter in the N. and E. The chief occupation of the people is agriculture, the other industries being spinning and weaving, manufactures in wood and metals; pottery, and shoemaking. There is also a considerable trade in cloth and silk. The principal agricultural products are rice, *tawári*, *rági*, wheat, *bájra*, sugar-cane, barley, and pulses. Tobacco is cultivated to a small extent. The entire revenue of the district amounts to £233,371, of which £179,321 is derived from the land revenue, and £17,597 from the local fund cess. Of the remainder £15,444 is derived from stamps, £14,998 from excise, assessed taxes yield £2344, and forests £3669. Of a total area of 4591 square miles, 1894·63 square miles are returned as cultivable, and 1729·7, or 37½ per cent. of the

total area, are actually under cultivation. The last settlement of the land revenue was made for a period of thirty years at various times between 1848 and 1864. The total imperial expenditure in the district amounts to £98,097. The following towns have a population of more than 5000 inhabitants:—Belgaum, 26,947; Gohak, 12,612; Athani, 11,588; Nipani, 9371; Temkanmardi, 5296; Hongal, 9001; Sankeshwar, 8905; Sawadati, 8180; Murgod, 7181; Ketur, 7166; Sádalgi, 6863; Mánoli, 6232; Chikadi, 6184; Nandighar, 5748; Hukéri, 5364; and Konganoli, 5143. Municipalities have been established in the first five of these towns, the necessary revenue being raised by *octroi* dues, except in the case of Temkanmardi,

where a house tax has been levied. The district contains 113 schools, with an attendance of 7624 pupils, or 0·8 of the entire population. Of the total number of schools, 2, with an attendance of 198 pupils, are private institutions, receiving Government aid. There is a stipendiary police of 684 men. The Kurira, a wandering and thieving tribe, the Kamais, professional burglars, and the Bárada, cattle-stealers and highwaymen, are special criminal classes. Of these the Bárada are the most troublesome. The district of Belgám was ceded to the East India Company by the Peshwá, under the treaty of June 1817, for the maintenance of a subsidiary force to be provided by the British Government.

## BELGIUM

**B**ELGIUM (Fr. *Belgique*, Ger. *Belgien*), is one of the smaller of the European states, among which it ranks 16th in point of area and 8th according to population. It lies between lat. 49° 30' and 51° 30' N., and long. 2° 32'

and 6° 7' E.; and is bounded on the N. by Holland, E. by Dutch Limbourg, Luxembourg, and Rhenish Prussia, S. and S.W. by France, and N.W. by the North Sea. It is somewhat triangular in form, the longest side—that which

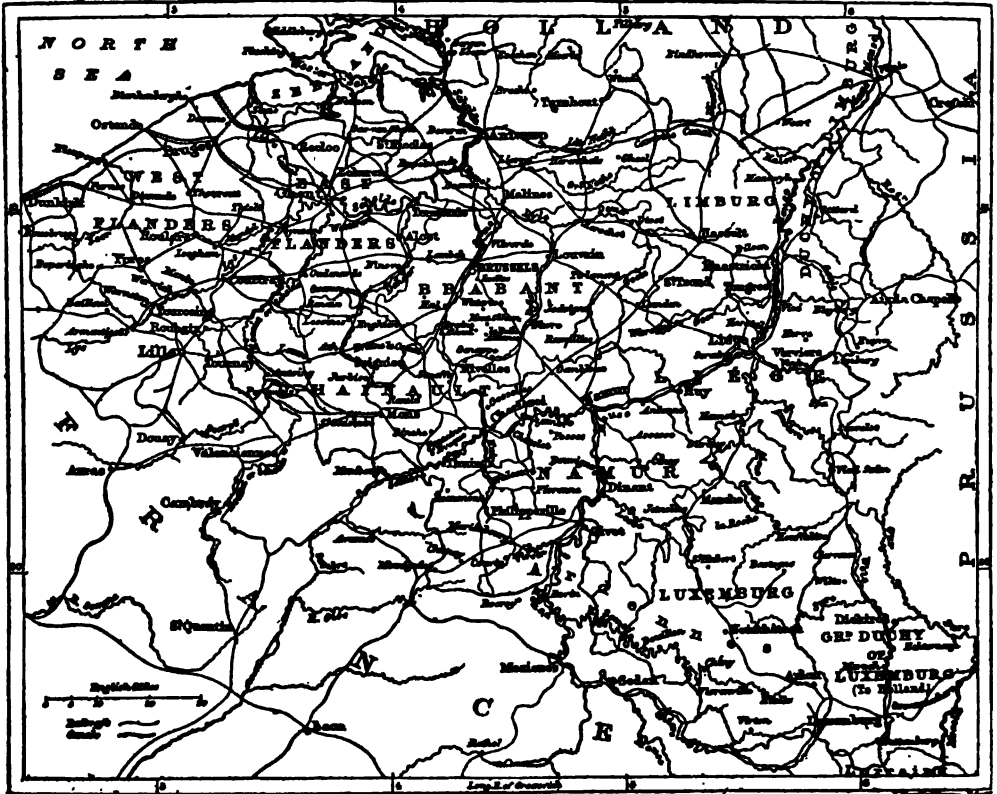

Sketch Map of Belgium.

adjoins France—being 384 miles in length. The length of its other boundaries are,—towards Holland 268 miles, Germany 59, Luxembourg 80, and the North Sea 41. Its greatest length from N.W. to S.E. (from Ostend to Arlon) is 174 miles, and its greatest breadth from N. to S. 105. It has an area of 2,945,593 hectares, equal to 7,278,968 English acres, or 11,373 square miles,—being about one-eighth of the area of Great Britain. This country is divided into nine provinces,—Antwerp in the N., West and East

Flanders and Hainault in the W., Namur in the S., Luxembourg in the S.E., Liége and Limbourg in the E., and Brabant in the centre.

Belgium is in general a very flat country having few elevations, and these rarely exceeding 2000 feet in height. They are principally to be found in the E. and S.E., while the N. and N.W. parts of the country bear a considerable resemblance to Holland. The elevations of Belgium take their rise in France, and extend generally in a N.E. direc-

tica. A chain proceeding from the neighbourhood of the sources of the Saône separates the waters of the Meuse from those of the Moselle, passes Arlon and Neufchâteau, then extends in a north-eastern direction towards Bastogne, and finally enters Prussia. A branch of this chain goes off at Neufchâteau, proceeds northward towards Liège, passes St Hubert, and separates the Ourthe from the Meuse. A part of the Ardennes also extends into Belgium, and separates the basin of the Meuse from that of the Scheldt. It proceeds in a north-eastern direction, passing Fontaine l'Évêque, Gembloux, Ramillies, and Tongres, then, gradually decreasing in height, it turns northward to Asch, and afterwards N.W. to Hechtal, Lommel, and Turnhout. A series of heights on the frontier of France, near Chimay, extends in a N.W. direction towards Namur, and separates the Meuse from the Sambre.

The provinces of Liège, Luxembourg, and Namur present the greatest irregularities of surface. This part of the country is intersected by numerous ravines and streams with steep and rocky banks, by deep valleys, and by ridges of hills, which often have precipitous and rocky escarpments. The vegetation here is of a very poor and languid character. The greater part of the region is covered with dense forests, marshy and uncultivated plateaus or poor pasture land, and corn is very rarely cultivated. Descending towards the coast the forests become less extensive; and rye, oats, and potatoes take the place of the pasture land. In the western and north-western provinces are extensive and well-watered plains, which, from their great fertility and the high state of their cultivation, are the boast of the Belgians and the admiration of strangers.

In the provinces bordering on the sea the land is in some places so low as to require to be protected from inundation by dikes. These parts are called *polders*. Numerous places along the banks of the rivers are also protected by embankments; these are called *interior polders*. About a sixtieth part of the kingdom (50,000 hectares, or 193 square miles) is thus artificially gained from the sea and rivers.

The coast of Belgium is said to be undergoing a change similar to that of Scandinavia,—in some parts a gradual elevation, and in others a gradual depression. Nieuport is said to be on the axis of this change, from which, northward to the mouth of the Scheldt, the sea is continually gaining upon the land, while southward to Pas de Calais it is losing.

The principal rivers are the Scheldt, Meuse, and Yser, with their tributaries. The Scheldt is navigable during its entire course through Belgium, and has a general direction from S.W. to N.E., passing through the province of Hainault, along the eastern boundary of West Flanders, traversing East Flanders, and finally forming the boundary between the provinces of East Flanders and Antwerp. Its entire length through Belgium is 108 miles. The Meuse has a course nearly parallel to that of the Scheldt, traversing the provinces of Namur, Liège, and Limbourg. It is 115 miles in length, during the whole of which it is navigable. The small river of Yser, which enters the sea at Nieuport, is navigable for about 26 miles. The navigable rivers connected with the Scheldt are,—the Dyle, which after receiving the Nethe at the village of Rumpet, takes the name of Buppel, and joins the Scheldt nearly opposite to Ruppelmonde; the Great and Little Nethe, which after their junction take the name of Nethe, and fall into the Dyle; the Demer, also an affluent of the Dyle; the Dender, which enters the Scheldt at Dendermonde; the Durme, which joins it near Thialrode; and the Lys at Ghent. The entire navigable length of these streams is 230 English miles. The navigable rivers of the Meuse are the Amblere and the Vesdre, affluents of the Ourthe; the Ourthe, which joins the Meuse at Liège; and the Sambre, which joins it

at Namur. The navigable length of these is 142 miles. The small river of Yperlee, which joins the Yser, is navigable for about 9 miles. The other streams are the Senne, the Haine, the Semoy, and the Lesse.

Besides these navigable rivers, Belgium has a number of canals for inland navigation, some of which are used also for irrigation. They are twenty-nine in number, and their entire length is 605,440 metres, or 376 English miles. The principal of these are the canals—from Bruges to Ostend, from Brussels to Charleroi, from Bochoit to Herenthals, from Brussels to Willebroeck, from Ghent to Bruges, from Liège to Maestricht, from Maestricht to Bois-le-Duc, from Pommeroeul to Antwerp, from Flamschendale to Nieuport, the Louvain canal, the Liève, and the Moervaert. Each of these canals is upwards of 12 miles in length, and the longest, that from Brussels to Charleroi, upwards of 46 miles. The entire length of the river and canal navigation of Belgium is 1006 English miles.

Belgium possesses a number of mineral springs, the principal of which are the hot springs of Chaudfontaine, situated about five miles from Liège, and the mineral spring of Tongres; but the most celebrated waters are those of Spa. The ferruginous springs of Huy were formerly in considerable repute, but are now little used.

The climate of Belgium is similar to that of England, but is a little colder in winter and hotter in summer. In the south-eastern parts the atmosphere is more pure and bracing than in the lower parts towards the N.W., where it is frequently damp and hazy. Frost rarely appears before the middle of October or after the middle of April. Observations made at Brussels from 1833 to 1872 give the mean annual temperature as 50°·6 Fahr.,—the mean maximum being 57°·2, and the mean minimum 44°·1 Fahr. During that period there were no frosts in the five months from May to September inclusive, and snow fell only eight times in May and four times in October. The average number of foggy days annually, from 1833 to 1862, was 60, and with thunder 15. The annual average of days on which rain fell was 197, and the quantity of rain 28·04 inches, or 3 inches less than the rainfall at London.

The population of Belgium in 1831 was 3,785,814; in 1840, 4,073,162; in 1850, 4,426,202; in 1860, 4,731,957, and in 1873, 5,253,821, being 2,645,147 males and 2,608,674 females. The following table shows the population of the different provinces in each of the years 1831, 1850, and 1873 (31st December):—

	1831.	1850.	1873.
Antwerp .....	349,942	420,556	513,543
Brabant .....	561,826	784,617	922,468
East Flanders .....	742,978	783,460	854,366
West Flanders .....	608,226	681,127	682,921
Hainault .....	618,179	735,740	922,086
Liège .....	375,080	467,843	622,166
Limbourg .....	160,090	188,198	202,922
Luxembourg .....	160,762	192,528	206,069
Namur .....	212,784	274,073	316,321
	3,785,814	4,426,202	5,253,821

The principal towns are—Brussels, with 180,172 inhabitants; Antwerp, 141,910; Ghent, 128,424; Liège, 113,774; Bruges, 48,113; Verviers, 38,875; Tournay, 31,923; Malines, 38,540; Louvain, 32,814.

Belgium is the most densely populated country of Europe, having on an average 178 inhabitants to the square kilometre, which is equivalent to 461 to the square mile. The density differs greatly in the several provinces, being as high as 285 per square kilometre in East Flanders, 231 in Brabant, and 250 in Hainault; and as low as 86 in Namur, 84 in Limbourg, and 47 in Luxembourg. The general census of 1866 gives 124,001 as under one year of age; 549,077 between one and five years, and 494,322 between five and ten; while 299,711 were from sixty to seventy, 115,216 from seventy to eighty, 23,890 from eighty to ninety, 1292 from ninety to a hundred, and 12 a hundred and upwards. The number of

unmarried persons was 8,011,566, of married persons 1,528,548, of widowers and widows 287,724. As regards their places of birth, 3,348,506 had been born in the same commune in which they lived; 1,381,231 had been born in another commune of the same province; 288,672 had been born in another province of the kingdom, 13,044 in the ceded districts of Luxembourg or Limbourg, 26,435 in other parts of Holland, 32,021 in France, 20,701 in Germany, 3003 in England, and 2892 in other countries. In 1873 the births were 170,708, being 87,128 males, and 83,580 females, or 104 males to 100 females,—giving one birth to every 80·3 of the population, and 151 births to a hundred deaths. Of the births 158,585 were legitimate and 12,123 illegitimate, or 13 legitimate births to 1 illegitimate. The proportion, however, varies much in the different provinces, being 7·5 to 1 in Brabant, and 37 to 1 in Luxembourg. The number of marriages that took place was 40,598, and of deaths 112,873. Of the latter, 24,282 were under one year, and 16,730 between one and five years of age; 815 males and 62 females were by suicide, 2068 were from accidents, and 69 were murdered. The immigrations were 15,792, and the emigrations 7981.

The languages spoken in Belgium are French or Walloon (a dialect of the ancient French), and Flemish or Dutch. French is the language of the upper and educated classes, and is generally understood even in the Flemish parts of the kingdom. In 1866 those speaking French or Walloon amounted to 2,041,784; Flemish or Dutch, 2,406,991; French and Flemish, 308,361; German, 35,356, French and German, 20,448; Flemish and German, 1625; and the three languages, 4966. The French or Walloon is the prevailing language in the provinces of Hainault, Liège, Luxembourg, and Namur; the Flemish or Dutch in Antwerp, Brabant, the two Flanders, and Limbourg.

Since the formation of Belgium into an independent state, the Government has taken a laudable interest in all that concerns the advancement and happiness of the people; and not being trammelled by a respect for old laws or useless customs, it has adopted, as far as possible, the most improved systems of other countries. The whole system of government is based upon the broadest principles of rational freedom and liberality. All power emanates from the people, and can be exercised only according to law. The people are upon a strict equality in the eye of the law; personal liberty is guaranteed to all, as well as entire freedom in opinion and in religious worship. All the religious sects are endowed by the state, and large grants are also given annually for educational and charitable purposes. Home is inviolable, nor can any one be deprived of his property unless for the good of the state and for a suitable indemnity. Justice is open to all, as well as the means of education, and the benefits of the public charities. The press is free, and civil death is abolished. Any one may address petitions to the public authorities signed by one or more persons. Trial by jury is established for all criminal and political charges, and for offences of the press. The contents of letters are inviolable, and the post-office is responsible for all letters committed to it.

The government is a constitutional representative and hereditary monarchy. The legislative power is vested in the king, the chamber of representatives, and the senate. The judicial power is exercised by fixed tribunals, freed from all authoritative influences, judging publicly, and assigning reasons for their decisions. Affairs exclusively provincial or communal are managed by the provincial or communal councils.

The royal succession is in the direct male line in the order of primogeniture, to the exclusion of females and their descendants. The king's person is declared sacred, and his ministers are held responsible for the acts of the Government. No act of the king can have effect unless countersigned by one of his ministers, who thus becomes the responsible party. The king convokes, prorogues, and dissolves the chambers, and makes rules and orders necessary for the execution of the laws, but has no power to suspend or dispense with the execution of the laws

themselves. He nominates to civil and military offices, and commands the sea and land forces. He declares war, and concludes treaties of peace, of alliance, and of commerce,—communicating the same to the chambers as far as may be consistent with the interest and safety of the state. He sanctions and promulgates the laws, and has the power of remitting or reducing the punishments pronounced by the judges, except in the case of his ministers, to whom he can extend pardon only at the request of one of the chambers. In default of male heirs the king may nominate his successor with the consent of the chambers. The regency can only be conferred upon one person, and no change in the constitution can be made under his rule.

The people are represented in the Legislature by the Chamber of Representatives and the Senate, the members of which are chosen by the people. Each chamber determines the manner of exercising its own powers, and every session nominates its president and vice-presidents, and forms its *bureau*. No petition can be presented personally; and every resolution is adopted by the absolute majority, except in some special cases, when two-thirds of the votes of the members are required to be favourable; in the case of an equality of votes the proposition is thrown out. The chambers meet annually in the month of November, and should sit for at least forty days; but the king has the power of convoking them on extraordinary occasions, and of dissolving them either simultaneously or separately. On dissolution a new election must take place within forty days, and a meeting of the chambers within two months. An adjournment cannot be made for a period exceeding one month without the consent of the chambers.

The Chamber of Representatives is composed of deputies chosen directly by the people paying a certain amount of direct taxes. The number of deputies is fixed according to the population, and cannot exceed one member for every 40,000 inhabitants; at present they amount to 124. To be eligible for membership it is necessary to be a Belgian by birth or to have received the grand naturalization, to be in the possession of the civil and political rights of the kingdom, to have attained the age of twenty-five years, and to be resident in Belgium. The members not residing in the town where the chamber sits receive, during the session, an indemnity of 200 florins (£16, 13s. 4d.) each per month. The members are elected for four years, one-half going out every two years, except in the case of a dissolution, when a general election takes place. This chamber has the parliamentary initiative and the preliminary vote in all cases relating to the receipts and expenses of the state, and to the contingent of the army.

The electors of the Chamber of Representatives have also the nomination of the members of the Senate. To be eligible as a senator it is necessary to be a Belgian by birth or to have received the grand naturalization, to be in the enjoyment of civil and political rights, to be domiciled in Belgium, to be forty years of age, and to pay at least 1000 florins (£84) of direct taxes. In those provinces where the number of those paying 1000 florins of taxes does not amount to one in every 6000 inhabitants, this proportion is made up by those paying the highest amount below that sum. The permanent deputations of the provincial councils annually prepare a list of those who are eligible to the Senate. In 1874 the number of these was 453. At the age of eighteen the heir-presumptive to the throne has a seat in the Senate, but he has no voice in its deliberations till he attain the age of twenty-five. The senators receive no indemnity. They are elected for eight years, one-half going out every four years, except in the case of a dissolution. The Senate is composed of half as many members as the Chamber of Representatives, the number at present being 62.



In order to be a general elector it is necessary to be a Belgian by birth or to have received the grand naturalization, to be twenty-one years of age, and to pay direct taxes to the amount of at least 20 florins (\$3a. 4d.) In 1874 the total number of general electors was 111,136, or at the rate of 21.15 per 1000 of the population.

The king appoints and dismisses his ministers at pleasure. No member of the royal family can be a minister, nor any but a Belgian, or one who has received the grand naturalization. Ministers have a right of admission to the chambers, and may demand a hearing; but they have no voice in the deliberations unless they are members. The chambers can at any time require the presence of the ministers. No act or writing by the king can free a minister from responsibility. The Chamber of Representatives has the power of accusing the ministers, and of bringing them before the court of cassation, which alone has the right of judging them, in all cases of offences committed in the exercise of their functions. There are six ministers, viz., of foreign affairs, of the interior, of justice, of finance, of war, and of public works.

Naturalization is of two kinds, the one conferring on the foreigner all the civil and political rights belonging to a Belgian, with certain exceptions specified by law, such as the right to vote in the choice of members for the legislative chambers or of sitting there; to obtain these the *grand naturalization* is requisite. The registration-fee for the former is 500 francs; for the latter, 1000. Since 1831 only 47 have received the grand naturalization and 1527 the ordinary.

For civil purposes the provinces are divided into 26 arrondissements, 204 justice-of-peace cantons, and 2528 communes; and for military purposes, into 41 arrondissements, 303 military cantons, and 2568 communes.

In each province is a governor named directly by the king, for the purpose of superintending and securing the due execution of the laws, and a provincial council, composed of Belgian citizens at least twenty-five years of age, residing in the province, and in the enjoyment of civil and political rights. The number of members of each provincial council is made to depend upon the population, and varies in the different provinces from one for every 11,500 of the population in Brabant and Hainault, to one for every 5000 in Limbourg and Luxembourg. Each canton, however, is entitled to be represented by at least one member, and the number of members for each canton depends upon the population according to the scale fixed for the province. The total number of members in 1874 was 559,—Antwerp council having 58; Brabant, 73; East Flanders, 80; West Flanders, 69; Hainault, 76; Liège, 67; Limbourg, 40; Luxembourg, 41; and Namur, 55. The electors of the members of the provincial councils were formerly the same as the electors of the legislative chambers, but in 1872 the provincial franchise was lowered, and the number of electors in 1874 was 219,619, or 41.80 to 1000 inhabitants. A provincial elector requires to be a Belgian or to have received naturalization, and to pay taxes to the amount of 20 francs (16s.) Members of the chambers, governors, and persons in the employment of the state or province, are ineligible as councillors. The councils have an annual session of not more than four weeks; but the king can convoke them on extraordinary occasions. Those not residing in the provincial capital receive an indemnity during the session. Each provincial council appoints a permanent deputation for conducting business in the interval between the sessions, particularly in matters requiring immediate attention. It is composed of six members chosen for four years, one-half going out every two years.

These councils are of the highest importance to the country. They watch over the interests of their several

provinces, prepare the budgets, direct taxation, and superintend public works. They give a healthy impulse to agriculture, trade, and commerce; direct the construction of roads, canals, and bridges; and extend the benefits of education and religion throughout the country. The communes have the power of appeal to the king if they consider themselves aggrieved by any of the acts of the provincial council, or of the permanent deputation.

Matters exclusively communal are managed by communal councils. The councillors are Belgian citizens in the full enjoyment of civil and political rights, and, except in some special cases, resident in the commune. They are elected for six years, one-half going out every three years. The number of the councillors is from 7 to 31, in proportion to the population of the commune, which varies from under 1000 to upwards of 70,000 inhabitants. Communal electors require to be Belgians or to have received naturalization, and to pay taxes to the amount of 10 francs (4s.) The total number of electors in 1874 was 347,441, being 66.13 per 1000 of the population. Communes with less than 20,000 inhabitants have two aldermen, and those having more than that number have four. There is also in each commune a burgomaster, who, as well as the aldermen, is chosen by the king from among the members of the communal council.

Full liberty is guaranteed to all in the exercise of the public or private rites of their worship; nor does the state interfere in any way in matters of religion, except where the public safety may be concerned or the laws infringed. Almost the entire population of Belgium is Roman Catholic, there being only about 15,000 Protestants and 3000 Jews. The ministers of each denomination are paid by the state,—the amount so paid in 1873 being 4,648,757 francs, or £185,950, of which Roman Catholics received 4,568,200 francs, Protestants 69,336, Jews 11,221.

The kingdom is divided into six Roman Catholic dioceses,—the archbishopric of Malines, and the bishoprics of Bruges, Ghent, Liège, Namur, and Tournay. The archbishopric has three vicars-general, and a chapter of twelve canons; and each of the bishoprics, two vicars-general, and a chapter of eight canons. In 1873 there were 156 deaneries, 233 rectories, 2788 chapels of ease, 148 public chapels, and 1745 vicariates.

The temporal affairs of the churches are managed by a vestry-board and a board of wardens. There is an ecclesiastical seminary in each diocese, and scholarships are annually given by the state to certain of the students upon the presentation of the chief of the diocese. The state also contributes to the salaries of the professors by an annual grant to each of the seminaries, except that of Liège which has sufficient funds otherwise. The provinces are bound to provide and maintain suitable buildings for these seminaries. There are a number of religious houses in Belgium for males and females, whose lives are spent in pious contemplation, teaching, and visiting the sick. The number of these houses in 1866 was,—for males 178, and for females 8144; the number of persons in the former was 2991, and 15,205 in the latter.

The Protestant Evangelical Church is under a synod, composed of the clergymen of the body and a representative from each of the churches. It sits in Brussels once a year, when each member is required to be present, or to delegate his powers to another member. The Anglican Church has eight pastors and as many chapels in Belgium,—three in Brussels and one in each of the towns Antwerp, Bruges, Ghent, Ostend, and Spa.

The Jews have a central synagogue at Brussels, three branch synagogues of the first-class at Antwerp, Ghent, and Liège, and two of the second-class at Arion and Namur. The civil and religious affairs are conducted by a

consist of nine members, six of whom are appointed by the central, and one by each of three first-class synagogues. The grand rabbi, who is at the head of this body in Belgium, is, *ex officio*, a member of the consistory.

The Belgian Government has shown itself thoroughly alive to the great importance of a general diffusion of education among the people. Numerous public schools and literary and scientific institutions are established throughout the country, supported out of the communal, provincial, or Government funds. Different classes of inspectors are appointed to visit and report upon the state of education in their various districts. Prizes, scholarships, and other rewards are bestowed upon those that distinguish themselves most in the prosecution of their studies. Religious and moral instruction is under the direction of the sect to which the majority of the pupils belong; but those connected with other sects may be exempted from attendance on this course. Normal schools have also been established for the purpose of securing trained and efficient teachers. The schools are open to all, and gratuitous instruction is provided for those who may not otherwise have the means of acquiring it. Yet, with all these advantages, there are still many among the lower classes growing up in ignorance. According to the census of 1866, out of a population of 4,827,833, only 2,279,891 were able to read and write, giving, if we exclude all of seven years of age and under, only 58 per cent. of the population. This proportion varied considerably in the different provinces, being as high as 77 in Luxembourg and 71 in Namur, and as low as 48 in East and 51 in West Flanders. In 1843 only 49 per cent. of those who took part in the balloting for the militia were able to read and write; in 1853, 56; in 1863, 62; and in 1873, 74. Out of 42,313 in 1873, 8678 were unable to read or write, 2027 could read but could not write, 13,887 were able to read and write, and 16,836 had received a superior education. This shows that it is not enough merely to provide the means of education in order to secure an educated population. In the industrial localities the parents are generally anxious to get their children admitted as soon as possible into workshops and manufactories, and in rural districts they are engaged in tending cattle or in field labour.

The educational institutions may be divided into four classes, viz., primary, middle, superior, and special.

A law passed in 1842 enacted that there should be at least one primary school in every commune, except in certain cases where primary education is already sufficiently provided for by private schools, or where one school may serve for several neighbouring communes. The communes may also adopt one or more private schools, possessing the legal qualifications, to occupy the place of the communal school. The branches taught are reading, writing, and the elements of arithmetic; the rudiments of the language spoken in the locality,—French, Flemish, or German; moral and religious instruction; and the legal system of weights and measures, in most schools taught practically. In many of the schools gymnastics, music, the elements of drawing, the outlines of history and geography, and the rudiments of the natural sciences, are also taught. The communes are obliged to afford gratuitous instruction to all the children within their bounds whose parents are in poor circumstances or are otherwise unable to educate them. The primary schools are under the surveillance of the communal authorities and Government inspectors; and the imparting of moral and religious instruction is superintended by delegates from the religious bodies. Each province has a general inspector of the primary schools, who is appointed by the king, and inspects, at least once a year, all the communal schools in his district. Under him are the cantonal inspectors, who must visit the schools in their dis-

tricts at least twice a year. In 1872 the primary schools submitting to inspection were—communal, 3949; adopted, 469; private, 18; and boarding, 22; besides which there were 990 private schools and 230 boarding schools not under inspection. Of the inspected schools 1353 were for boys, 1284 for girls, and 1821 for both sexes; and of the non-inspected 267 were for boys, 693 for girls, and 261 for both sexes. The total number of primary schools was 5678, giving on an average 2.21 schools to each commune, and 1.13 to each 1000 of the population. The total number of scholars attending these schools was 618,937 (or 12.3 per cent. of the population), of whom 313,166 were boys and 305,772 girls; 518,141 were at inspected schools, and 100,796 at non-inspected. The number of scholars attending the communal schools was 449,940, of whom 325,432 were instructed gratuitously; and attending the adopted schools 63,594, of whom 42,521 were receiving gratuitous instruction. The total number of teachers and assistants was 10,629, of whom 5394 were males and 5235 females; of these, 4656 males and 2977 females were in the communal or adopted schools. The teachers in the communal schools are appointed by the communal councils, which have the power of suspending them for a period not exceeding three months, the Government decreeing as to their absolute dismissal or reinstatement. They are required to have attended, for at least two years, the classes of a normal school.

Besides the primary schools properly so called, there are in many localities other establishments where primary instruction is communicated, as the infant, adult, manufacturing schools, &c. The infant schools are for children between two and six years of age. There were in 1872, 780 of these schools, of which 212 were communal, 220 private but under inspection, and 348 private and non-inspected. The total number of pupils was 78,181.

In the adult schools the branches taught are generally the same as in the communal primary schools. The communal councils are invited to establish such schools, and of late years considerable progress has been made in this direction. In 1863 the number of adult schools was 1194, with in all 188,890 scholars; and in 1872, 2351, with 199,957 scholars. In the latter year 1454 of the schools were communal, 74 private inspected, and 823 private non-inspected. Of the scholars 98,558 were males, and 101,399 females; 56,880 were at communal schools, where 54,630 were receiving gratuitous instruction, and 7362 at adopted schools, where 7179 were gratuitously instructed. There are also primary schools annexed to prisons, hospitals, and depôts of mendicants, and reform schools. The number of these in 1872 was 97, and of scholars 6485. Considerable sums are given by Government for providing food, clothing, and other necessaries for the poor children attending the primary and infant schools.

The expenses of public primary education fall in the first instance on the commune; and in case of insufficiency of funds, the province, and finally the state, come to its assistance. Each commune, however, must contribute a sum equal to at least two per cent. upon its direct taxation before being entitled to claim any assistance from the province or state. The total expenditure for public primary education was,—in 1843, 2,651,639 francs; in 1853, 4,465,411; and in 1863, 9,372,259. In 1872 it was 16,300,843 or £648,033, of which 1,326,659 francs were school fees received, 506,512 public or private donations, 5,863,561 were contributed by the communes, 1,584,010 by the provinces, and 6,643,415 by the state.

The middle schools are divided into two classes, those supported by the Government, and those maintained by the communes. The former are of two kinds—(1), the royal atheneums, called also the middle superior schools; and (2), the middle inferior schools, or the middle schools properly

so called, including the former superior primary, as well as the schools formerly known as industrial and commercial schools.

There are ten royal atheneums, two in Hainaut, and one in each of the other provinces, viz., in the towns of Antwerp, Brussels, Bruges, Ghent, Mons, Tournay, Liège, Hasselt, Arlon, and Namur. In each of these are two courses, the one for the humanities and the other for a professional education. The professional course is divided into a lower division, comprehending a course of three classes, each of one year, and an upper division, with three sections, the commercial, industrial, and scientific, each divided into two classes, and extending over two years. In 1872 the number of students at the atheneums was 3562, of whom 623 were in the preparatory classes, 1157 in the humanity section, and 1782 in the professional.

In the state middle schools the courses are arranged so as to occupy three years. To some is annexed a preparatory section, making a year more. The number of these schools in 1872 was 50, with 9012 scholars.

The communal middle schools are of two grades, a first and second,—the former embracing 17 schools, the latter 16. They ought to be based upon the same principles, and teach the same branches as the royal atheneums and middle schools. In 1872 the number of scholars in the first or higher grade of schools was 1381, of whom 239 were in the preparatory classes, 790 in the humanity section, and 412 in the professional. The number of scholars in the lower grade of schools was 1828, of whom 1274 were in the lower sections and 554 in the higher. Most of these schools have libraries, museums of natural history, and chemical laboratories attached to them. There are in addition to these 75 unendowed colleges, of which 45 are Episcopal and 11 Jesuit.

The educational staff consists of a prefect of studies in the atheneums, and a rector in the middle schools, professors, regents, and masters. The prefects, professors, rectors, and regents are nominated by the king, and the masters and teachers by the minister of the interior. The diploma of a professor *agregé* of either degree is bestowed by a special jury after a searching examination. It is given without regard to the place where the candidate has studied. The prefects and rectors reside on the premises, and have the general direction and management of the institutions over which they are placed. Each has to report annually as to the state and condition of the institution under his care, and to register the conduct and progress of the scholars.

The middle, like the primary schools, are subjected to a regular system of inspection. The literary and scientific branches are under the superintendence of two inspectors and an inspector-general nominated by the king. To one of the inspectors is especially confided the mathematical and natural sciences, and to the other the humanities; the other branches, as history, geography, and the commercial sciences, may be committed to either of the inspectors or to the inspector-general. The inspector has to examine and report upon the state and discipline of each establishment, the methods employed in teaching, the progress made by the pupils, and the merit and seal of the teachers. The *conseil de perfectionnement* for the direction and improvement of middle education is composed of from eight to ten members, mostly professors in the universities, presided over by the minister of the interior or his deputy, and meets at least four times a year. A general competition takes place annually among the scholars of the atheneums and colleges receiving grants from Government, to which, however, scholars from other establishments may be admitted. The examinations are both written and oral; and the rewards are of three kinds, prizes, *accessits*, and honourable mention.

The amount contributed by the state to the atheneums in 1872 was 467,575 francs, to the state middle schools 418,589, and to the communal middle schools 184,079. The amount contributed by the communes to the atheneums was 291,937 francs, to the state middle schools 169,320, and to the communal middle schools 232,359.

The superior instruction establishments are the four universities,—two belonging to the state, at Ghent and Liège, the free university at Brussels, and the Catholic university at Louvain.

Each of the state universities has faculties of philosophy and literature, science, law, and medicine. In each there are 8 professors in philosophy, 9 in the sciences, 7 in law, and 8 in medicine. One or two additional professors may be added to each of the faculties in case of necessity. The professors are nominated by the king, and cannot exercise any other profession without the consent of the Government.

Attached to each university are a number of *agregés* named by the king. Their title is honorary, and they are chosen from among those students who have most distinguished themselves at the public competitions or final examinations, from professors of middle instruction, or from members of the civil or military body of engineers. They are nominally attached to one of the faculties, but are not prohibited from exercising any of the liberal professions, and in case of any of the professors being unable to perform his duties, a substitute is chosen from among the *agregés* attached to that faculty.

The universities are under the management of a rector, a secretary, deans of faculty, the *senatus academicus*, and the board of assessors. The rector is nominated by the king for three years, and has the direction of all academic matters. The secretary is appointed annually by the king from a list of two candidates nominated by the *senatus academicus*. The deans of the faculties are chosen annually by the professors of each faculty, and have the right of convoking the professors of their faculty. The *senatus* and the board of assessors are convoked by the rector; the former is composed of the professors, under the presidency of the rector, and the latter of the rector, secretary, and the deans of faculty.

Each student pays annually for enrolment 15 francs, and then takes out a ticket for the branches of the course in which he intends to take his examinations. For philosophy and literature, and for law, the annual ticket costs 250 francs, and 200 francs for the other faculties. The instructions are given in the French language. Subsidies are accorded by Government to the universities for the libraries, botanical gardens, cabinets, &c.; but the towns of Liège and Ghent are bound to maintain the buildings. The sum granted by the state to the two universities in 1873 was 937,919 francs.

Attached to the university of Ghent is a school for civil engineers. The preparatory course extends over two years, and comprehends the mathematical, physical, and natural sciences necessary to the subsequent courses. The special course is divided into two sections, the one for engineers of roads and bridges, and the other for architectural engineers. This course continues for two or three years. The third course, which lasts for three years, is for industrial engineers or persons engaged in arts or manufactures. They are instructed in the application of the various sciences to the arts and manufactures, particularly to the mechanical arts.

Similar to the above is the mining school attached to the university of Liège. The first course is preparatory to the other two. The special course includes all the branches necessary to a mining engineer. The third course is for those desirous of obtaining a knowledge of mining, min-

erals, &c., more particularly as connected with the arts and manufactures. This last course extends over three years.

The free university of Brussels has faculties of philosophy and literature, of science, of law, and of medicine, courses in which are given by ordinary and extraordinary professors and *agregés*. Each student pays annually 15 francs for enrolment, and a fee of 200 or 250 francs for the courses in any of the faculties. The fee for single classes is generally 50 francs. An annual subsidy of 10,000 francs is allocated to the university by the provincial council of Brabant, and the permanent deputation has the right of annually presenting ten youths of the province for gratuitous instruction. A subsidy of 50,000 francs is also allocated annually by the communal council of Brussels. The university is governed by an administrative council, composed partly of permanent members and partly of members chosen annually by the professors of the four faculties and the former students of the university. This council is presided over by the burgomaster of Brussels, who has a casting vote in its proceedings.

The Catholic university of Louvain is governed by a grand rector, nominated and revocable by the episcopal body. A vice rector is also nominated by the episcopal body on the advice of the grand rector. The rector nominates the secretary and other functionaries of the university. The faculties are philosophy and literature, the mathematical, physical, and natural sciences, law, medicine, and theology. The courses of the five faculties are given by ordinary and extraordinary professors and lecturers, nominated by the episcopal body on the presentation of the rector. The enrolment-fee for the first year is 10 francs, and 5 francs annually thereafter. The annual fee for courses in the faculties varies from 200 to 250 francs, except the theological courses, which are gratuitous. It has an extensive library, cabinets of mineralogy, zoology, &c., and a botanical garden. The numbers of the students at each of the universities in 1874 were—Ghent, 222; Liège, 518; Brussels, 580; and Louvain, 909.

A competition takes place annually among the scholars of superior instruction, and at these competitions two gold medals are given in each of the faculties. There are also twelve travelling scholarships given annually, tenable for two years, to such students as have taken their doctor's degree with the highest distinction and wish to travel, to enable them to visit foreign countries; and about sixty bursaries of 400 francs each are given annually to poor students to enable them to prosecute their studies. Besides these there are connected with the universities a number of private bursaries, the management and bestowal of which are in the hands of particular persons or corporations in terms of the acts of foundation.

The special educational institutions of Belgium are of various kinds, and are generally in a very efficient state. They include (in addition to the engineering and mining schools already mentioned) normal schools, military schools, navigation schools, &c., and academies and schools of design, painting, sculpture, music, &c.

There are two Government normal schools for primary teachers, one at Liège and the other at Nivelles,—the former having twelve and the latter thirteen professors, with a rector each. The course extends over three years, and during the last year of attendance the pupils are exercised in teaching in the primary schools of the town. There are also seven episcopal normal schools, in which similar branches are taught, except that the principles of the Catholic religion are more particularly inculcated. The chief diocesan nominates the rectors and professors. The course lasts for four years. Besides these there are several private normal schools for males and females, one or more institutions for the training of female teachers by each province, and normal

primary sections attached to the middle schools of Bruges, Ghent, Huy, Virton, and Couvin.

Bursaries of 200 francs each are annually given by Government to assist poor students attending the normal schools; and students of promise, who have taken diplomas at either of the Government primary normal schools, may be admitted to the normal school of middle instruction at Nivelles. The course here is for two years. There are also for the training of teachers for the superior middle institutions, the normal school of the humanities at Liège, and the normal school of the sciences at Ghent. Candidates for admission must be young men of superior talents, qualifying them to perform creditably the duties of professor, and they must pass certain examinations. The branches taught in both schools extend over three years. In the school at Liège there are fourteen bursaries of 500 francs each, given to the poorer students, the recipients becoming bound to act as professors in one of the middle schools for five years. There are five bursaries of 500 francs in connection with the school at Ghent.

There is a military school at Brussels for training officers for the army. The number of scholars in 1873 was 129. The courses are divided into two sections; the one, which extends over two years, is preparatory to the second, which also extends over two years, and is divided into special branches qualifying for the infantry, cavalry, or marine. A school has been established in Liège for the purpose of educating the sons of the military for the army. The course extends over five years, and the pupils generally enter the army about the age of sixteen. They are placed in the army according to their proficiency, some as sub-officers and corporals, others as common soldiers. The pupils in 1873 were 252.

Each regiment has a regimental school for training young men in the army for subalterns, and a number of evening schools for affording the means of education to the soldiery. Attendance at one of these schools is obligatory on all subalterns and corporals whose education is not complete, according to their position.

There is at Measines a Royal Institution for the education of daughters of military men who have died or been disabled in the service of their country. They are admitted from seven to fourteen years of age, and remain till their eighteenth year. They are instructed in branches necessary to qualify them as governesses, teachers, domestic servants, &c., and situations are provided for them on leaving.

Schools of navigation have been established at Antwerp and Ostend for furnishing properly educated masters for merchant vessels, where instruction is given gratuitously. Certificates of qualifications as master or mate are given by a jury of examiners. There has also recently been formed at Antwerp a superior institute of commerce to afford instruction, theoretical and practical, in the commercial sciences, the course extending over two years.

A Government agricultural institute was established at Gembloux in 1860 for affording theoretical and practical instruction in agriculture and kindred subjects. There are seven professors and three assistants, and a demonstrative gardener. The course lasts for three years. Students in 1873, 71. There is a similar institution at Ghent, which in 1873 had 31 students. A school of practical horticulture and arboriculture was established at Vilvorde in 1855, which in 1873 had 29 students; the course is for three years. A similar institution at Gendbrugge has been closed since 1871. There is also a veterinary college at Brussels with, in 1873, 84 students. The course is for four years.

The academies and schools of design, painting, sculpture, &c., are divided into three classes:—1. The royal academies of the fine arts, in which painting, sculpture, architecture,

and engraving are taught in the most efficient manner; 2. Academies of design established in the principal towns, and giving instructions in designing, architecture, and the principles of geometry and perspective drawing; 3. Schools of design established in all the larger towns for instructing young persons and artisans in the elements of designing and architecture. In 1873 there were 76 such academies and schools in the kingdom, having 9966 pupils.

The Royal Academy of the Fine Arts at Antwerp is principally intended to afford gratuitous instruction in painting, sculpture, architecture, and engraving, and to propagate and encourage a taste for the fine arts. In 1873 there were 1665 scholars. A competition in one of the branches of the fine arts is annually held in Antwerp, the laureate at which receives a pension of 3500 francs annually for four years, to enable him to perfect himself in his art in Germany, France, and Italy. The second prize is a gold medal of 300 francs. The Royal Academy of the Fine Arts at Brussels is an institution similar to that at Antwerp. Instruction is gratuitous, and the vacancies are filled up by competition.

The Royal Musical Conservatory at Brussels is under the direction of the minister of the interior, aided by a commission of seven members nominated by the king, with the burgomaster of Brussels as honorary president. The instruction is gratuitous, and includes vocal and instrumental music, composition, and the Italian language. The number of scholars in 1873 was 529. There are six bursaries of 250 francs, and ten of 125 francs, in connection with this institution. There is a similar establishment at Liège, with (in 1873) 694 scholars. Music, both vocal and instrumental, is much cultivated in Belgium; and musical schools and societies are established in almost all the principal towns and throughout the country. In 1873 there were, besides those mentioned, 108 musical schools and societies, with 7440 members. A competition in musical composition takes place every two years at Brussels, the laureate receiving a pension of 3500 francs for four years, to enable him to study in France, Germany, and Italy. The second prize is a gold medal of the value of 300 francs.

Belgium possesses a great number of learned societies, as the Royal Medical Academy, the Royal Academy of Science, Literature, and Art, &c. The Royal Medical Academy has its seat at Brussels. It is divided into six sections, and has 36 titular and 18 assistant members, with 24 corresponding and an indefinite number of honorary members. Each of the sections has certain branches of medical science assigned to it. The academy answers any questions that may be proposed to it by the Government, upon matters connected with public hygiene, and makes researches in all subjects connected with or tending to advance medical science. Gold medals are given annually for the best essays on prescribed subjects. It receives an annual grant of 20,000 francs from the state.

The Royal Academy of Science, Literature, and Art also has its seat at Brussels. It is divided into three classes, for the sciences, literature, and the fine arts; the first two are each subdivided into two sections, and the last into branches, for painting, sculpture, engraving, architecture, and music. Each class is composed of 30 members, 50 foreign associates, and not more than ten native correspondents. Each class proposes annually certain subjects for essays, to which gold medals of the value of 600 francs are adjudged. The academy receives an annual grant of 40,000 francs from the state. Connected with this academy is a royal commission of history for the purpose of searching for and editing old chronicles and documents tending to throw light upon the early history of the country. There has also just (1875) been instituted by the king a prize of

25,000 francs (£1000) to be given annually for the best work published on a subject previously announced of interest to Belgium. Every fourth year the competition is to be open to foreigners.

There is a Government inspector-general of science, literature, and art, who has the general superintendence of that department, under the minister of the interior. Under him are two administrative boards, the one for literature and science, and the other for the fine arts.

The Royal Observatory for astronomical and meteorological observations is under the management of a director and three assistants. In the observatory are instruments specially provided by Government for the use of young men desirous of making meteorological or astronomical observations.

The Royal Museum of Brussels, for the reception of objects in natural history belonging to the state, is under the direction of a council of five members appointed by the king. There is also a museum of industry, containing models and plans of machines used in arts, manufactures, and agriculture. Annexed to this museum is a school where instruction is given gratuitously in the construction of such machines. It possesses a chemical laboratory, library, &c. There is also a royal museum of war instruments at Brussels, and in 1870 a royal botanic garden was laid out for aiding in the study of botany and horticulture. The royal museum of painting and sculpture is under the direction of a commission, composed of a president and six members nominated by the king, and charged with the collection of works of ancient and modern masters for the museum. A triennial exhibition of works of living artists, Belgian and foreign, in painting, sculpture, engraving, architecture, and lithography, is held at Brussels. There are similar exhibitions held in Antwerp, Ghent, Liège, Bruges, &c. The geographical establishment at Brussels has a considerable collection of books and maps, a garden, a herbarium, collections of rocks, lava, fossils, &c.

Besides the libraries belonging to different societies, associations, &c., there are a number of public libraries in Belgium. The principal of these is the royal library of Brussels. It contained in 1871 about 301,500 volumes, 22,221 manuscripts, 53,556 engravings, and 19,517 medals and coins. This is the only library that receives copies of copyright works. The public library of Ghent is connected with the university. It has 80,000 volumes and 600 manuscripts, besides pamphlets, &c. The Liège public library has 68,000 volumes, about 26,000 pamphlets, and 430 manuscripts. The public library of the Louvain university is the most ancient in Belgium, and is particularly rich in works of ancient history, theology, and literature, including Hebrew, Greek, Latin, and Oriental. These libraries are open daily for consultation, and in almost all of them volumes are lent out at the discretion of the conservators.

The archives of Belgium contain a great number of interesting and valuable documents connected with the history of the country. These are carefully preserved, classified, and catalogued. The general archives of the kingdom at Brussels contain upwards of 100,000 documents, and the archives of Antwerp upwards of 70,000. Those at Bruges, Ghent, Liège, Mons, Namur, Tournay, Hasselt, and Arlon are ancient and important. The archives of the city of Bruges, at one time the grand commercial entrepôt of Europe, contain a number of valuable papers bearing upon the events of which this city was the theatre in the Middle Ages. Unfortunately, they do not go further back than 1280, the previous documents having been all destroyed by an extensive fire in that year.

The benevolent and charitable institutions of Belgium are numerous and open to all. The duty of supporting

them falls in the first instance upon the commune, afterwards upon the province, and finally, in case of necessity, upon the state. They are divided into three classes:—(1.) Those affording assistance or an asylum to the poor in case of age, infirmity, disease, want of work, &c., including dispensaries, foundling and maternity hospitals, deaf-mute and blind institutions, &c.; (2.) Those more particularly designed for the prevention and suppression of vagabondage and beggary, as depôts of mendicity and reform schools; and (3.) Those specially intended to foster a spirit of independence and foresight among the working classes, as savings-banks, and assurance and mutual assistance societies.

Every town of importance and many of the rural communes have hospitals for the aged, infirm, and indigent. Asylums for incurables are also numerous, but much less so than the former. Farm hospitals have been established in the rural communes of the two Flanders, where the inmates contribute by work to their own maintenance. They form small agricultural colonies of old people and children, mutually assisting each other. The products of the farms generally suffice for their maintenance.

Foundling hospitals are established in Antwerp, Brussels, Louvain, Bruges, Ostend, &c. The children generally remain only for a short time in the hospitals. They are pensioned out to inhabitants of the rural communes till their twelfth year, at which period the wardship of the hospital terminates. Inspectors are appointed to visit the children quarterly, to report upon their physical condition, see that they are attending school, &c. There are maternity hospitals at Brussels, Louvain, Ghent, Liège, Bruges, Nieuport, and Tournay, in several of which courses of midwifery are given. Maternity societies for aiding females with money, medicine, &c., are formed in many of the towns. There are a number of lunatic asylums, which in 1873 had in all 6801 patients, of whom 5024 were paupers. A colony of lunatics has been formed in the commune of Gheel, province of Antwerp, where, under the direction of a permanent committee, they are pensioned out among the inhabitants, and generally employed in agricultural labours. There are also a number of institutions for the education of the deaf and dumb and the blind.

To prevent the misery, and frequently the crime, arising from the want of employment among the working classes, charity workshops have been established in Ghent, Liège, and other towns. These are accessible to all workmen without employment and in poor circumstances. The able-bodied are paid according to their work, and the aged and infirm according to their necessities. The workshops of apprenticeship and improvement are intended not only to supply work to the unemployed, but principally to initiate the people in the exercise of new or improved branches of industry, and to instruct the young men in some trade or profession by which they may be able to gain an honest livelihood. They have been found of great benefit to many of the poorer classes who would otherwise have been brought up as vagrants and beggars. The apprenticeship generally lasts from four to six months. Similar to these are the manufacturing schools, intended principally for girls, where they are employed in the manufacture of lace, &c. These are supported partly by the state and partly by the provinces and commune, but many of them are private. In 1872 there were of these institutions—39 communal, 144 private but subject to inspection, and 294 non-inspected. The total number of persons was 26,739, of whom 1067 were in communal establishments, 9649 private inspected, and 16,023 non-inspected; 25,565 were females and 1174 males.

There are three depôts of mendicity or workhouses in

the kingdom, at Bruges, Hoogstraeten, and Beckheim. In 1873 they contained 1819 persons. A reform school was founded in Ruysselede in 1848 for male vagrants and mendicants under eighteen years of age. It contains about 500 members, employed in cultivating a large farm of 128 hectares. At a short distance is a similar institution for 400 girls and infants, between two and seven years of age. There is also a similar school for girls and infants at Beerssem.

In each commune is a *bureau de bienfaisance*, for assisting the poor with money, food, clothing, &c., and, where there are no hospitals, providing them with medical attendance and medicines. It also contributes to the maintenance and education of poor children, foundlings, deaf-mutes, and lunatics. There are also *Monts de Piété*, or charitable institutions for lending money to the poor upon the security of pledges, in twenty of the larger towns. *Caisse de prévoyance*, both general and special, and mutual aid societies—to succour the members in sickness, pay their funeral expenses, and aid their families—are numerous.

The judicial system of Belgium consists of courts and tribunals of various kinds, as the court of cassation, the courts of appeal, and of assize, tribunals of primary instance, of commerce, &c. The court of cassation or annulment sits at Brussels, and is divided into two chambers, the one for civil and the other for criminal matters. It is composed of a president-general, a president of the chamber, and fifteen councillors. It decides upon appeals against judgments pronounced in the other courts and tribunals in contravention of legal forms. There are three courts of appeal: one at Brussels, for the provinces of Antwerp, Brabant, and Hainaut; another at Ghent, for the two Flanders; and a third at Liège, for Liège, Limbourg, Luxembourg, and Namur. In the capital of each province is a court of assize, composed of a councillor, deputed from one of the courts of appeal, who presides, and two judges chosen from among the presidents and judges of the primary tribunal, where the court is held. Crimes, graver misdemeanours, political offences, and abuses of the press are judged by the courts of assize. In each judiciary arrondissement is a tribunal of primary instance, judging in misdemeanours belonging to the correctional police, in civil matters, and in commercial affairs where there is no commercial tribunal. The number of judges varies from three to ten in each tribunal. Tribunals of commerce are established by law in several principal towns. They judge definitively in civil matters of not more than 2000 francs, but above that sum their decisions are subject to appeal, as in the tribunals of primary instance. In several of the manufacturing towns are councils of *prud'hommes*, composed of master tradesmen and workmen. They decide in all questions and disputes arising between masters and workmen. For all criminal and political cases, as well as offences of the press, trial by jury is established. The jury is composed of twelve persons chosen by lot from a list of thirty. Justices of the peace and judges of the tribunals are chosen directly by the king. The councillors of each court of appeal, and the presidents and vice-presidents of the tribunals of primary instance in its district, are chosen by the king from two double lists of candidates, the one presented by the court of appeal, and the other by the provincial council. The councillors of the court of cassation are named by the king from two double lists, the one presented by the senate, and the other by the court of cassation. The judges are appointed for life, and cannot be suspended or deposed but by a judgment. They cannot hold any salaried office under the Government, or, at least, must perform the duties of it gratuitously. The duties of public minister at the court of cassation are exercised by a procurator-general, and two advocates

general; and by a royal procurator with substitutes before each of the tribunals of primary instance and courts of assize and appeal.

Councils of war are held in the chief place of each province, with the exception of Limbourg, which is joined to Liège, and of Luxembourg, which is united with Namur. They decide in crimes and misdemeanours committed in their provinces by the military of a rank not higher than captain. The military court for the whole of Belgium has its seat at Brussels. It is composed of five members, one of whom is a councillor of the appeal court of Brussels, delegated annually to preside; the rest are general or superior officers chosen by lot every month. All officers of a grade superior to that of captain are amenable to this court. It also decides on appeals from the provincial or other military courts.

Besides the ordinary police, there are commissaries of police, royal procurators, *juges d'instruction*, &c. The commissaries of police, and in the communes where these are wanting the burgomasters or delegated aldermen, are specially charged with searching out and proving all contraventions of the police laws. The royal procurators are charged with discovering and prosecuting for all offences coming within the jurisdiction of the courts of assize or the correctional tribunals of police. There is at least one *juge d'instruction*, or examining judge, in each *arrondissement* who is specially charged with the collection of evidence, and with bringing the culprit before the tribunal. There is a council chamber composed of at least three judges, including the *juge d'instruction*, for the preliminary examination of culprits.

The prisons are of three kinds—(1), central prisons; (2), houses of surety; and (3), houses of arrest. The central prisons are—(1), the central penitentiary at Ghent for different classes of criminals; (2), the penitentiary at Louvain, on the solitary system, for prisoners condemned to more than one year's imprisonment, except those condemned to imprisonment for life; (3), the penitentiary and reformatory for young criminals at Namur; (4), the penitentiary and reformatory at St Hubert for young delinquents belonging to the rural population, acquitted but put at the disposal of Government; (5), the branch penitentiary and reformatory at Namur for young criminals and young delinquents, acquitted, belonging to the town population. The number in the prisons in 1873 was 1568, in the reformatories 751. The houses of surety are established in the capital of each province, where there is a court of assize, and the houses of arrest are in the capital of each *arrondissement*, the seat of a court of primary instance, where there is not already a house of surety. In these houses are confined the prisoners whose term does not exceed six months if the prison is a common one, and three years if on the solitary system. The number of prisoners in these prisons in 1873 was 2437. In connection with many of these, schools, workshops, and circulating libraries have been established. The prisoners are employed in various kinds of work. Those condemned to compulsory labour receive no remuneration, but those condemned to solitary or correctional imprisonment receive a part of the produce of their labour, which in the case of the latter is frequently applied in mitigation of their punishment. Premiums are also given for good conduct, zeal, and progress in their labours.

Since 1830 the agricultural state of the country has been much improved. A superior council of agriculture is specially charged with the promotion and superintendence of the agricultural interests of the country; and in each of the provinces a commission of practical men is nominated to encourage the introduction of improvements in the different branches of agriculture and report annually upon

the state of agriculture in their provinces. Every five years a grand agricultural exhibition of horses, cattle, agricultural implements, and produce is held in Brussels, at which a number of gold and silver medals, &c., are given as prizes. Local exhibitions are also held frequently in the various districts.

The agriculturists above twelve years of age, including female servants, form one-fourth of the entire population. Females are extensively engaged in agricultural work, being to the males as 61 to 100. In 1866 the number of horses was 283,163; of cattle, 1,242,445; sheep, 586,087; swine, 632,301. To improve the breeds of horses a Government stud of stallions is maintained at Terruereu.

The cultivated land of Belgium amounts to 2,663,753 hectares, or 6,582,123 acres, of which 1,339,795 hectares are in the hands of the proprietors, and 1,323,958 are let to tenants. In West Flanders four-fifths are in the hands of tenants; in Luxembourg nearly five-sixths are in the hands of the proprietors; and in most of the other provinces about one-half is let to tenants. The land is divided into numerous and mostly small patches (nearly 600,000). Of these 43 per cent. do not exceed 50 ares; there are 12 per cent. not exceeding one hectare, or 2½ acres, 29 per cent. not exceeding 5 hectares, 7½ per cent. not exceeding 10 hectares, and less than 8 per cent. of greater extent. The Belgians, particularly in Flanders, are averse to the introduction of improvements in their agricultural operations, and their implements are generally rude and clumsy. Their lands are, however, cultivated with great care and are very productive. Of the cereal crops rye is the most extensively cultivated, and forms an important article of food for the working classes. Wheat and oats are also extensively cultivated, the former particularly in the provinces of Hainault, Brabant, and West Flanders. Comparatively little barley is raised. Hops, chicory, tobacco, rape and other oleaginous plants, hemp, flax, madder, beet, &c., are common. Of these the most extensively cultivated is flax, principally in the two Flanders. Tobacco was much more extensively grown a few years ago than at present; it is now almost entirely confined to the two Flanders and Hainault. The chicory plant is principally raised in Hainault. The cultivation of beet for the extraction of sugar is continually increasing, and numerous establishments have been formed for its preparation. The leguminous plants, pease, beans, and tares, are used principally as fodder for cattle; the most common are beans. The beet root is even more extensively cultivated as fodder than as an industrial plant, particularly in the provinces of West Flanders, Liège, Hainault, and Brabant. Potatoes are largely grown in all the provinces; and, next to potatoes, turnips are the most extensively cultivated of the alimentary roots. The fallow ground, formerly considerable, is now only of small extent, being principally sown in fodder crops. Clover is the principal fodder crop. The number of hectares occupied with the principal crops in 1866 were—wheat, 283,542; oats, 221,743; rye, 288,966; barley, 43,617; beans, 24,263; pease, tares, &c., 13,645; potatoes, 171,397; flax, 57,045; colza, 26,412; beet root for sugar, 18,074; turnips, carrots, &c., 28,806; hemp, hops, chicory, tobacco, &c., 13,775. Vegetable gardens occupied 37,329; meadow, 365,805; fallow, 53,891.

Belgium is rich in various kinds of minerals, as coal, iron, calamine, &c., which form a valuable source of employment to many thousands of its inhabitants.

The coal may be divided into two great basins. The western basin is the most important, and has an estimated extent of 90,051 hectares (or about 222,400 acres),—75,725 in the province of Hainault, and 14,326 in Namur. The extent of the eastern bed is estimated at 44,062 hectares—41,745 in the province of Liège, and 2317 in

Namur. All varieties, from anthracite to the richest gas-coal, are found. In 1873 there were 285 coal-mines in the country, employing 107,902 persons, and producing 15,778,401 tons of coal valued at 337,637,360 francs. The iron districts are the arrondissement of Charleroi, and the provinces of Namur, Liège, and Luxembourg. Besides the iron-mines in Charleroi, Hainault contains a copper-mine, commenced in 1849, and calamine and blende mines. Iron is also found in small quantities in the arrondissements of Mons and Tournay. In Namur the iron ore is rich and plentiful, and constitutes the principal mineral wealth of the province. Veins of lead and zinc are also wrought to a considerable extent. The iron-mines of Luxembourg are much inferior to those of Namur. The principal are those of Durbuy, Ruette, Grandcourt, Halanzy, and Musson. The ferruginous basins of Theux and La Reid are of the greatest importance, both as public works, and from the quantity of ore that they furnish. Lead and zinc are found here almost always in the same bed. Alumiferous schist is common in several parts of the province. In 1873 the different metallic mines yielded 13,952 tons of blende, 28,630 of calamine, 11,280 of lead, 36,661 of pyrites, and 503,563 of buddled iron ore. The number of workmen employed in these mines was 3758. Under the minister of the interior the mines are superintended by a corps of mining engineers; each of the six mining districts has an ordinary engineer, and each of the two divisions a chief engineer. A sub-engineer is appointed over a certain number of mines.

Marble is abundant in many parts of Belgium; and the black marbles, as those of Dinant and Gochene, may rival the finest productions of other countries. There are also numerous quarries of freestone, granite, limestone, slate, &c. The principal quarrying provinces are Namur and Hainault. In 1873 there were 2230 quarries in the country, employing 22,435 men, and yielding the value of 38,353,171 francs.

The number of works in 1873 for the preparation of iron was 331; steel, 3; lead, 7; copper, 6; zinc, 1; alum 1; glass, 72; and 41,845 workmen were engaged. The value of the iron manufactures was upwards of 246,000,000 francs; glass, 46,000,000; zinc, 38,000,000; steel, 7,700,000; copper, 6,000,000; lead, 4,700,000, &c.

Notwithstanding many vicissitudes, flax, the most ancient, still forms one of the most important branches of industry in the country. In 1866, 57,045 hectares of land were occupied in the cultivation of flax, and a considerable number in hemp. The declared value of flax and hemp yarn imported in 1872 was 10,427,000 francs; of flax yarn exported, 80,904,000; of hemp, 7,155,000; and of flax and hemp cloths, 37,170,000.

Cotton also forms an important branch of industry, which is at present in a more flourishing condition than at any former period. In 1872 the value imported of raw cotton was 57,241,000 francs; cotton yarn, 6,214,000; and cotton cloths, 12,754,000; the value exported of cotton yarn, 6,358,000; cotton cloths, 19,083,000.

The manufacture of woollens forms also an important branch of industry. The wool for this purpose is principally imported from Prussia, Saxony, &c., the native produce being small in quantity and chiefly used in hosiery. In 1872 the value of the wools imported was 160,079,000 francs; yarn, 6,902,000; manufactured stuffs, 23,814,000; exported wool, 10,291,000; yarn, 64,523,000; manufactured stuffs, 44,850,000.

In 1866 the numbers employed in the various flax, hemp, woollen, and cotton manufactures, were 114,547 males and 71,111 females. The chief of the other manufactures are silk, lace, ribbons, beer, spirits, vinegar, sugar, salt, bricks and tiles, porcelain, earthenware, glass, crystal, paper,

leather, ropes, &c. In 1872 the excise duties on beer and vinegar amounted to 15,547,605 francs; spirits, 16,946,225; foreign wines, 4,765,800; and sugar, 7,516,388.

In 1850, 2165 sailing and steam vessels, of 314,797 tons, entered Belgium; in 1860, 3780 vessels of 667,287 tons; in 1870, 5658 vessels, of 1,575,293 tons; and in 1872, 6134 vessels, of 1,878,106 tons. Of the last 3082 were steam vessels, of 1,158,484 tons. In 1850 the number of vessels that left Belgium was 2214, tonnage 235,745; in 1860, 3959, tonnage 694,225; in 1870, 5406, tonnage 1,534,513; and in 1872, 6241, tonnage 1,907,530. Of the last 3081 vessels, with 1,169,254 tons, were steamers. The numbers and tonnage of vessels entering from and leaving for different countries in 1872 were as follows:—

INWARDS.		OUTWARDS.			
	Vessels.	Tonnage.			
England.....	3176	843,779	England.....	4178	1,214,979
Russia.....	444	178,371	Sweden and		
Sweden and			Norway.....	544	124,354
Norway...}	638	155,597	United States..	121	94,790
United States..	173	116,622	Germany.....	236	79,760
Argentine Rep.	169	95,575	France.....	209	65,913
Germany.....	312	87,785	Russia.....	148	56,646
France.....	218	62,182	Argentine Rep.	44	38,309
Chili and Peru	49	80,514			

Expressed in millions of francs the value of the imports in 1850 was 236; of the exports, 263; of goods in transit, 206; in 1860—imports, 516; exports, 469; in transit, 408; in 1870—imports, 520; exports, 690; in transit, 857; and in 1872—imports, 1277; exports, 1051; in transit, 1049. Of the imports in 1872, 315 were from France, 230 from England, 164 from Holland, 158 from the German Zollverein, 80 from the United States, 77 from the Argentine Republic, 62 from Russia, 35 from Uruguay, 24 from Brazil, and 23 from Sweden and Norway. Of the exports 320 were to France, 237 to England, 223 to the German Zollverein, 120 to Holland, 18 to Switzerland, 17 to the Hanseatic towns, 14 to the United States, 12 to Italy, and 11 to Russia. Of the goods in transit 434 were from the German Zollverein, 321 from France, 96 from England, and 92 from Holland; 341 were to the German Zollverein, 245 to England, 237 to France, and 121 to Holland. The values of the principal articles of merchandise imported for home consumption expressed in millions of francs were—wool, 160; grain of all kinds, 126; raw hides, 71; iron ore and cast and wrought iron, 61; cotton, 57; resins, 48; minerals and metals, 47; coffee, 42; wood for building, 41; grease and tallow, 37; silks, 30; horned cattle, 29; oleaginous seeds, 29; woollen stuffs, 23; fermented liquors, 21; oils, 17; machinery, 10. The values of the principal exports were—coal, 85; flax, 80; wrought iron, 69; woollen yarn, 64; raw hides, 53; woollen stuffs, 44; raw sugar, 41; machinery, 39; flax and hemp stuffs, 37; grain of all kinds, 37; flax and hemp yarn, 31; grease and tallow, 25; paper, 21; resins, 21; unwrought zinc, 21; coke, 20; cotton stuffs, 18; glass and crystal wares, 17; wool, 16; candles, 15; butter, 14; arms, 13. The values of the principal goods in transit were—flax and hemp stuffs, 204; wool, 147; woollen stuffs, 102; haberdashery and hardware, 39; silks, 38; cast and wrought iron, 35; cotton, 33; grain of all kinds, 30; coffee, 23; woollen yarn, 20; flax and hemp yarn, 19; cattle, sheep, swine, 18; cotton stuffs, 17; fermented liquors, 16; glass and crystal wares, 16; machines, 13. In 1872 the exports from Belgium to the United Kingdom were £13,211,044, and the imports from the United Kingdom to Belgium £6,499,062.

There are twenty-three chambers of commerce and manufacture established in the principal towns, the members of which are nominated by the king from a triple list of



candidates presented to him by the chambers. The members of each vary in number from nine to twenty-one, one-third going out annually. They present to the Government or legislative chambers their views as to the best means of increasing the commercial and industrial prosperity of the country, report annually upon the state of their districts, and give useful information or direction to the provincial or civic authorities under their administration. There is a superior council of industry and commerce, composed of two delegates chosen annually by each of the chambers of commerce of Antwerp, Brussels, Ghent, Liège, Mons, and Charleroi, one elected by each of the other chambers of commerce, and a certain number of members chosen by the king, not exceeding a third of the others. The president and two vice-presidents are nominated by the king for each session. The council considers matters affecting commerce and industry, and such questions connected therewith as may be submitted to it by the Government.

Belgium possesses a great number of commercial and financial associations, joint-stock companies for carrying on public works or other enterprises, assurance companies, private banking companies, railway companies, &c. It has eight commercial exchanges, under the direction of Government, namely, in Antwerp, Brussels, Ghent, Bruges, Ostend, Mons, Termonde, and Louvain. In 1822 the General Society for the Encouragement of National Industry was formed at Brussels, under a royal charter for 27 years, which has since been extended to 1875 and 1905. It has a social capital of 15,500,000 florins, divided into shares of 500 florins each, bearing interest at 5 per cent. The administrative body consists of a governor, six directors, a secretary, and a treasurer. It discounts bills, receives money at interest, grants loans and advances on titles and other deposits, &c. The National Bank, instituted by charter granted in 1850 and renewed 1872, has its seat at Brussels, and has branches in all the provincial capitals and several other towns. Its capital is 50,000,000 francs, in shares of 1000 francs each. It pays a dividend of 5 per cent. upon the shares, and one-third at least of the profits exceeding 6 per cent. goes to form a sinking fund. The administration consists of a governor nominated by the king, six directors, and a council of censors. The banking operations are superintended by a Government commissary; and a report upon its state is presented to the Government every month. The state funds are deposited in this bank. The Bank of Belgium, chartered in 1835, has a capital of 50,000,000 francs. Its seat is at Brussels. The Bank of Flanders, established in Ghent, has a capital of 10,000,000 francs.

After England, there is no country in Europe where, in proportion to its extent, the roads are more numerous or better kept than in Belgium. They are of three kinds,—those maintained by the state, and those by the provinces and communes. The total length of the two latter cannot be given with accuracy; that of the first is 1187 leagues.

A bill was passed in 1834 authorizing the establishment of a system of railroads, of which Malines was to form the centre, and the line from Brussels to Malines, opened May 5, 1835, was the first railway in operation on the Continent. The Government railways are wrought on account of the Government, and are under special administration. The total length of the various lines of railway in operation in 1873 was 616 leagues (of 5000 metres), of which 125 leagues belonged to the state, and 543 were conceded to others; of the former 117 leagues were double lines. The amount expended by Government in the construction of railways to the end of 1873 was 361,287,299 francs, or £14,451,491.

In 1849 a system of postage was introduced into Belgium similar to that in this country. In 1873 the total number of letters that passed through the post-office was 55,654,859; newspapers, 52,771,524; and packets of printed matter, 25,697,33. In 1860 the numbers were—letters, 23,960,846; newspapers, 26,358,020; and book parcels, 6,668,452.

The first electric telegraph, which was that between Brussels and Antwerp, was introduced into the country in 1846 by an English company. A law passed in 1850 authorized the Government to purchase this, as also to establish telegraphs on all the lines of railway. The telegrams sent out in 1873 were 1,739,817 to different parts of the country, and 676,393 to other countries, besides 153,330 in transit.

For an account of the Belgian army and civic guard, see ARMY, vol. ii. p. 615.

The following table shows the annual income and expenditure for various years :—

	Income.	Expenditure.
1844 .....	198,810,598 fr.	195,185,657 fr.
1850 .....	182,877,187	118,730,904
1860 .....	155,631,571	159,025,877
1865 .....	169,055,072	188,792,787
1870 .....	190,587,002	216,907,800
1871 .....	207,705,993	238,191,223
1873 .....	213,352,689	251,974,513

The details of the revenue and expenditure of the last three of these years, arranged under their several heads, are as follows :—

	REVENUE.				EXPENDITURE.		
	1870.	1871.	1872.		1870.	1871.	1872.
	Francs.	Francs.	Francs.		Francs.	Francs.	Francs.
Land tax .....	19,176,009	19,272,846	20,258,082	Public debt .....	42,680,891	47,628,468	48,765,178
Personal tax .....	12,174,684	12,404,060	13,230,067	Pensions .....	4,367,879	4,366,898	4,288,619
Trade licences .....	4,374,797	5,103,814	5,509,728	Justice .....	14,620,711	14,515,580	14,473,638
Rent of mines .....	440,020	528,251	572,377	Foreign affairs .....	3,819,005	4,277,056	4,374,445
Custom duties .....	22,057,152	20,339,578	18,943,388	Interior .....	13,179,716	14,056,481	14,714,366
Excise duties .....	29,495,085	25,219,641	27,024,218	Public works .....	39,804,463	51,082,306	59,341,373
Stamp duties .....	39,633,635	44,806,269	49,277,477	War .....	59,116,612	44,005,577	39,590,955
Domains, Forests, &c. ....	3,444,497	2,413,004	2,555,137	Finance .....	13,308,096	13,545,257	13,936,198
Post-offices .....	4,114,555	5,123,506	4,723,594	Deficiencies & Repayments	946,553	839,598	1,403,490
Railways, &c. ....	41,825,031	57,172,844	58,428,526	Special services .....	25,063,874	43,924,117	51,086,352
Miscellaneous .....	11,839,645	13,486,213	16,970,612				
Reimbursements .....	1,981,882	1,835,067	1,859,493				
<b>Total .....</b>	<b>190,587,002</b>	<b>207,705,993</b>	<b>213,352,689</b>	<b>Total .....</b>	<b>216,907,800</b>	<b>238,191,223</b>	<b>251,974,513</b>

The public debt of Belgium at the end of 1873 amounted to 966,920,513 francs or £38,676,820. Except the share of the old debt of the Netherlands which fell to it, most of the national debt has been incurred in the construction of railways and other works of public utility.

In the time of the Romans this portion of the Netherlands was included in Gaul, and formed part of that division of it which was known as *Gallia Belgica*. It was inhabited mostly by Celtic tribes, but there were also not a few of German race. The latter were subsequently largely

increased by irruptions from the north, so that in the 5th and 6th centuries, under the rule of the Franks, they formed the principal element of the population. For several centuries the history of the Franks is the history of the Netherlands. Afterwards the country was divided into a number of independent duchies, counties, and free cities. Among these may be mentioned the duchies of Brabant, Limbourg, and Luxembourg, the counties of Flanders, Hainault, and Namur, the bishopric of Liège, the lordship of Malines, &c. Of these the county of Flanders rose to be superior to all the others, and became distinguished for its industry and commercial activity. In 1385 the male line of the counts of Flanders became extinct, and their possessions passed into the hands of the dukes of Burgundy, who soon after, in various ways, came into possession of the whole of the Netherlands. In order to strengthen their power they sought to repress the spirit of liberty, and to do away with the free institutions that had sprung up in the country; but notwithstanding this the people continued to increase in wealth and prosperity, and industry and commerce flourished more and more among them. In 1477 Mary of Burgundy, only daughter and heiress of Charles the Bold, married the Archduke Maximilian, son of the Emperor Frederick IV., and thus the Netherlands came into the possession of the House of Austria. Maximilian succeeded to the imperial throne in 1493, and the following year he resigned the government of the Netherlands to his son Philip, then a youth of seventeen years of age. The latter, in 1496, married Joanna, daughter of Ferdinand and Isabella of Castile, and died in 1506, leaving to succeed him a son who afterwards became Charles V. During the reign of this monarch the Protestant religion began to spread in the country, though its adherents were subjected to much persecution. His son and successor, Philip II. of Spain, by his cruel persecutions and his attempt to establish the Inquisition in the country, drove the people into open rebellion. The duke of Alva, who was sent at the head of a Spanish army to reduce them to subjection, perpetrated upon them the most horrid cruelties, devastating the country in every direction, and erecting scaffolds in every city. At length the northern portion of the Netherlands succeeded in establishing its independence, and became the republic of the Seven United Provinces, while the southern portion, or Belgium, continued under the rule of Spain. In 1598 Philip ceded Belgium to his daughter Isabella and her husband the Archduke Albert, under whom it formed a distinct and independent kingdom. Attempts were then made to restore the prosperity of the country and improve its internal condition; but, unfortunately, Albert died without leaving issue in 1621, and the country again fell into the hands of Spain.

For many years Belgium continued to share in the declining fortunes of Spain; and in the wars that broke out between that power and France and Holland, it was exposed to the first attack, and peace was usually purchased at the expense of some part of its territory. By the treaty of the Pyrenees (1659) the county of Artois, Thionville, and other districts were ceded to France. Subsequent French conquests, confirmed by the peace of Aix-la-Chapelle (1668), took away Lille, Charleroi, Oudenarde, Courtray, and other places. These were, indeed, partly restored to Belgium by the peace of Nimeguen (1679); but, on the other hand, it lost Valenciennes, Nieuport, Cambray, St Omar, Ypres, and Charlemont, which were only in part recovered by the peace of Ryswick (1697). After the conclusion of this last treaty the Spanish Government attempted to restore prosperity to Belgium by the introduction of new customs laws, and by other means, particularly by the construction of canals to counteract the injury done to

its commerce by the closing of the navigation of the Scheldt by the Dutch. But these attempts were of little avail in consequence of the breaking out of the War of the Spanish Succession, which was only brought to an end by the peace of Utrecht in 1713. By this treaty Belgium was assigned to Austria, and took the name of the Austrian Netherlands. Yet such was the enfeebled state of the country that Holland retained the right, which had been conceded to her during the late war, of garrisoning the principal fortresses on the French frontier, and her right to close the navigation of the Scheldt was also recognised. In 1722 a commercial company was formed at Ostend by Charles VI., but this was sacrificed in 1731 to the jealousy of the Dutch. During the Austrian War of Succession almost the whole country fell into the hands of the French, but was restored to Austria by the peace of Aix-la-Chapelle (1748). Belgium was undisturbed by the Seven Years' War (1756-63), and during the long peace which followed enjoyed considerable prosperity under the mild rule of Maria Theresa, whose representative here, Prince Charles of Lorraine, conducted affairs with great judgment and moderation. The empress did much for the advancement of education, founding, among other institutions, the Belgian Academy of Sciences, and opposed the undue power of the clergy. Her son and successor, Joseph II., got into difficulties with Holland, and compelled that power to withdraw her garrisons from the frontier towns, but was unsuccessful in his attempts to free the navigation of the Scheldt. It was, however, in his attempts to reform internal abuses that he failed most signally here as in other parts of his dominions. He excited the religious feelings of the people against him, by attempting to curb the power of the priests, and he offended the states by seeking to overturn the civil government. Numbers of the malcontents left the country, and organized themselves as a military force in Holland. As the discontent became more general the insurgents returned, took several forts, defeated the Austrians at Turnhout, and overran the country. On 11th December 1789, the people of Brussels rose against the Austrian garrison, and compelled it to capitulate, and on the 27th the states of Brabant declared their independence. The other provinces followed, and, on 11th January 1790, the whole formed themselves into an independent state under the name of United Belgium, with a congress to manage its affairs. After the death of Joseph II. his successor, Leopold II., issued a proclamation on 3d March 1790, wherein he promised the restoration of the former constitution if the people would return to their allegiance. This, however, they refused to do, and they also rejected the proposal of a congress to meet at the Hague for the settlement of their differences. In the end of November, therefore, a strong Austrian army was sent into Belgium, and the country was subdued without any great opposition. The constitution as it existed at the end of the reign of Maria Theresa was restored, an amnesty was proclaimed for past offences, and the opposition of the states was put down. The short period of peace which followed was terminated by the breaking out of the war with revolutionary France. The battle of Jemappes (7th Nov. 1792) made the French masters of the country to the south of Liège; and the battle of Fleurus (26th June 1794) put an end to the Austrian rule in Belgium. The treaty of Campo Formio (1797) and the subsequent treaty of Lunenburg (1801) confirmed the conquerors in the possession of the country, and Belgium became an integral part of France, being governed on the same footing, receiving the *Code Napoleon*, and sharing in the fortunes of the Republic and of the Empire. (See FRANCE.) After the fall of Napoleon and the conclusion of the first peace of Paris (30th May 1814), Belgium was for some months ruled by an Austrian governor-general, after which it was united with Holland under

Prince William Frederick of Nassau, who took the title of king of the Netherlands (23d March 1815). The Congress of Vienna (31st May 1815) determined the relations and fixed the boundaries of the new kingdom; and the new constitution was promulgated on the 24th of August following, the king taking the oath at Brussels, Sept. 27.

The union, however, was not a particularly fortunate or happy one. It was brought about by the allied powers with little regard to the wishes or inclinations of the people, their main object being to form here a strong kingdom to serve as a check upon the ambitious designs of France. The character, habits, language, and religion of the Belgians were all against such an alliance. Through their connection and intercourse with France they had acquired much of the spirit, habits, and ideas of the people of that country; while the slow, staid, conservative habits and ideas of the Dutch were repugnant to them. The Belgians were chiefly engaged in agriculture and the manufactures, while the Dutch were mainly given to commerce and the fisheries. The French was the common language of Belgium, at least in the higher circles and in all public proceedings. But the principal difficulty arose from the difference in religion. The Roman Catholic clergy of Belgium were from the first opposed to a union with a Protestant country like Holland, and the great mass of the people were very ignorant, and much under the influence of the priests. Nevertheless, had a mild and conciliatory policy been adopted by the Dutch it would have done much to remove or lessen these difficulties. This, however, was not done. Belgium was regarded too much in the light of a conquered country, at whose expense they might lawfully enrich themselves. Though the population of Belgium was 3,400,000 and that of Holland only 2,000,000, the latter had as many representatives in the States-general as the former. This frequently rendered decision on important legislative questions a matter of extreme doubt and difficulty. In matters that affected, or were believed to affect, the two countries in different or opposite ways, the decision often depended on the accidental absence of a member on the one side or the other. The use of the French language was also attempted to be abolished in all Government and judicial proceedings. The great majority of the public offices were filled by Dutchmen, and the government was conducted principally in the interests of Holland. In 1830, of the seven Government ministers only one was a Belgian; in the ministry of the interior, of 117 officials only 11 were Belgians; in the ministry of war, of 102 officials only 3 were Belgians; and among 1967 officers of the army, only 288 were Belgians. The partisans of Holland attempt to explain away these facts, but with only very partial success; both sides, however, acquit the king of any intentional unfairness, and consider that he was led to act as he did by force of circumstances. The Belgians admit that he always manifested a sincere regard for their welfare, but accuse him of giving too ready an acquiescence to what they tauntingly called the schemes of their *Dutch cousins*.

Notwithstanding these drawbacks Belgium enjoyed during her union with Holland a degree of prosperity that was quite remarkable. The mineral wealth of the country was largely developed, the iron manufactures of Liège rapidly advanced in prosperity, the woollen manufactures of Verviers received a similar impulse, and many large establishments were formed at Ghent and other places where cotton goods were fabricated which rivalled those of England and far surpassed those of France. The extensive colonial and foreign trade of the Dutch furnished them with new markets for their produce; while the opening of the navigation of the Scheldt raised Antwerp to a place of the first commercial importance. The Government also did much in the way of improving the internal communications

of the country, in repairing the roads and canals, and forming new ones, deepening and widening rivers, and the like. Nor was the social and intellectual improvement of the people by any means neglected. A new university was formed at Liège, normal schools for the instruction of teachers were instituted, and numerous elementary schools and schools for higher instruction were established over the country. That the Government should take upon itself the direction and regulation of the education of the people was particularly hateful to the priests, still more so were the attempts subsequently made to improve the education of the priests themselves. The king had determined that no priest should be inducted who had not passed two years in the study of the *litera humaniores* before his ordination; and he appropriated a college at Louvain for that purpose, some of the professors in which were not priests, but laymen and Protestants. This gave great offence to the prelates and clergy, and some of the former, who had indulged in very intemperate language, were prosecuted. These proceedings were at the time applauded and encouraged by the active party of the Liberals, but afterwards these saw it their interest to join with the most bigoted of the Roman Catholics against the Government. With the view of terminating these differences the king in 1827 entered into a *concordat* with the Pope, settling the right of nomination to the bishoprics, and providing that the education of the priests should be under the control of the prelates, but that in the seminaries professors should be appointed to teach the sciences as well as what related to ecclesiastical matters. This, however, was far from satisfying the more violent of the clergy; and the two most opposite parties, the Catholic Ultramontanes and the French Liberals, united their efforts to effect the overthrow of the Government. The Liberals affected a zeal for the Catholic faith, and urged the clergy to make extravagant demands upon the Government, which they knew if granted would be hurtful to it, and if refused would increase the agitation then going on. Brussels was at this time, too, a city of refuge for the intriguing and discontented of almost every country of Europe, and the press teemed with libels not only against the Belgian Government, but also against almost every other, so that the people were constantly kept in a high state of political excitement. At length the Government took proceedings against some of the more notorious of the inflammatory writers, and several of them were banished from the kingdom.

Matters were in this state when the news of the success of the Paris revolution of 1830 reached Belgium. Numbers of the propagandists came to Brussels, where they paraded the streets and talked loudly in the public places of the glories of the Revolution and of the future destinies of France. The first outbreak occurred on the 25th of August, just a month after the commencement of that of Paris. A play, called *La Muette*, which abounds in passages well calculated to inflame the populace in their then excited state, was performed in the theatre, and when the curtain fell the audience rushed out into the street shouting, "Imitons les Parisiens." They were speedily joined by others, and the mob at once proceeded to deeds of violence, destroying or damaging a number of public buildings, manufactories, and private houses. The guards and posts in the centre of the city were overcome or quietly surrendered; the troops were drawn out, but they were too few in number to contend with the insurgents, and they either retreated to their barracks or were withdrawn to the upper part of the city, where they piled their arms in front of the king's palace, and renounced all attempts at suppressing the tumult. A number of the more influential and the middle-class citizens now enrolled themselves into a burgher guard for the protection of life and property, and to interpose in

a manner between the contending parties. The intelligence of these events in the capital soon spread throughout the provinces; and in most of the large towns similar scenes were enacted, commencing with plunderings and outrages by the mobs, followed by the institution of burgher guards for the maintenance of peace. The burgher guard of Brussels was most anxious to terminate the dispute without recourse being had to extreme measures. They demanded the dismissal of the minister, Van Maanen, who was obnoxious to the people, and a separate administration for Belgium without an entire separation of the two countries. The Government neither agreed to make these concessions nor did it resolve upon actual force, but adopted a sort of middle course which, by allowing things to go on, ended in converting a popular riot into a complete revolution. The heir-apparent, the prince of Orange, was sent on a peaceful mission to Brussels, but furnished with such limited powers as, in the circumstances, were utterly inadequate. On his arrival a conference was held, which extended over several days; and at the final meeting on 3d Sept., when a number of the members of the States-general were present, the prince had become so convinced that nothing but a separate administration of the two countries would restore tranquility, that he promised to use his influence with his father to bring about that object—the persons present on their part assuring him that they would heartily unite in maintaining the dynasty of the House of Orange. The king summoned an extraordinary States-general, which met at the Hague, 13th Sept., and was opened by a speech from the throne, which was firm and temperate, but by no means definite. The proceedings of the body were dilatory, and the conduct of the Dutch deputies exasperated the people of Belgium beyond measure. The moderate party in the country gradually lost their influence, and those who were in favour of violent measures prevailed, while the warlike demonstrations made by the troops kindled a feeling of animosity and stimulated preparations for defence. Although the States were still sitting at the Hague, the king's army was gradually approaching Brussels. It consisted of 14,000 well-appointed troops under the command of Prince Frederick; but its movements were too tardy if force was to be employed, and it was entirely out of place if conciliatory measures were to prevail. On 20th September the council resolved to take possession of Brussels, believing that the inhabitants were eager to receive the troops, and that their presence there would tend to restore peace; and orders were sent to Prince Frederick to that effect. On the 23d the troops advanced towards the city, and, with little opposition, occupied the upper or court portion of it, which is situated on a hill, by which the rest of the town is commanded. The fighting continued for three days without any definite result, when the prince ordered a retreat. The news of this soon reached Ghent, Bruges, Ostend, and other towns, which at once declared in favour of separation. A Provisional Government was formed at Brussels, which declared Belgium to be an independent state, and summoned a national congress for the regulation of its affairs. The council of the king now consented to separate administrations for the two kingdoms, but it was too late to restore peace. Antwerp was the only important town which remained in the hands of the Dutch, and the army on leaving Brussels had fallen back on this town. In the end of October an insurgent army had arrived before the gates, which were opened by the populace to receive them, and the troops, under General Chassé, retired within the citadel. A truce was concluded between the parties, but the Belgian officers were unable to restrain the fury of the populace who, with such weapons as they had, attacked the citadel. The general ordered a cannonade and bombardment of the

town, which continued for two days, destroying a number of houses and large quantities of merchandise. A suspension of hostilities then took place, but the misrepresentations and exaggerations of the proceedings which spread did much to inflame the minds of the Belgians still farther against the Dutch.

A convention of representatives of the five great powers met in London, in the beginning of November, at the request of the king of the Netherlands, but its attention was mainly directed to bringing about peace, and through it both sides were brought to consent to a cessation of hostilities. On the 10th November the national congress assembled at Brussels, consisting of 200 deputies chosen from the different provinces. Three important questions were decided by that assembly:—(1.) The independence of the country,—carried unanimously; (2), a constitutional hereditary monarchy,—by a majority of 174 against 13 in favour of a republic; and (3), the perpetual exclusion of the Orange Nassau family,—by a majority of 161 against 28 in favour of delay. On 20th December the conference of London proclaimed the dissolution of the kingdom of the Netherlands, at the same time that it claimed for itself the right of interfering even against the will of both countries to regulate the conditions of partition. On the 28th of January 1831 the congress proceeded to the election of a king, and out of a number of candidates the choice fell on the duke of Nemours, second son of Louis Philippe, but he declined the office. The congress then resolved on the election of a regent as a temporary measure, and they selected Baron Surlet de Chokier, who was installed on the 25th of February. This, however, did little to restore tranquillity to the country, and the partisans of the prince of Orange were still actively intriguing in his favour. At length, in the month of April, a proposition was privately made to Prince Leopold of Saxe-Coburg, widower of the Princess Charlotte of England, with the view of ascertaining whether, if chosen, he would accept the crown. It is remarkable that though his name was mentioned he was not among the number of candidates brought forward on the previous occasion. He answered in the affirmative, but strictly abstained from giving any authority to exertion being made in his favour. After many stormy discussions the election at length took place on the 4th of June, when 152 votes out of 196, four only being absent, determined that Prince Leopold should be proclaimed king of the Belgians, under the express condition that he "would accept the constitution and swear to maintain the national independence and territorial integrity." Leopold at once accepted, and made his public entry into Brussels on the 21st, when he was received with great cordiality. He subsequently visited other parts of the kingdom, and was everywhere received with demonstrations of loyalty and respect. While this was going on news suddenly arrived that the Dutch were preparing to invade the country with a large army. This had been brought together so secretly that the Belgians were unaware of its existence till it was about to cross the frontier. It comprised 45,000 infantry and 6000 cavalry, with 72 pieces of artillery, while Leopold could scarcely bring forward 25,000 men to oppose it. On the 2d of August the whole of the Dutch army had crossed the frontier. Leopold collected his forces, such as they were, near Louvain in order to cover his capital. The Dutch army advanced to the attack (9th August), and though the king displayed great bravery and determination, he was unable to impart his spirit to his undisciplined troops, who were speedily routed, the king himself and his staff making a narrow escape from being taken prisoners. He, however, made good his retreat to the capital; and a French army, which was ready to enter the country, then advanced, and the Prince of Orange saw the necessity of

retreating. A convention was concluded between him and the French general, in consequence of which he returned to Holland and the French army repossessed the frontier.

Leopold now proceeded with vigour to strengthen his position, and to restore order and confidence. French officers were selected for the training and disciplining of the army, the civil list was arranged with economy and order, and the other branches of the public service were reformed or rearranged. He kept on the best terms with the Roman Catholic clergy and the Roman Catholic nobility; and his subsequent marriage with a daughter of the French king (9th August 1832), and a contract that the children of the marriage should be educated in the Roman Catholic faith, did much to inspire confidence in his good intentions. While these things were going on the conference in London was engaged in determining the terms of peace, and a project of a treaty for the separation of the two states was drawn up and declared to be "final and irrevocable." The first basis of separation had determined that the grand-duchy of Luxembourg, which belonged to the king of Holland as grand-duke, should continue to belong to Holland. By the subsequent treaty of the eighteen articles, Belgium received the right to treat for the purchase or redemption of Luxembourg from Holland on fair terms. These articles were adopted by the Belgian congress in July 1831, but the king of Holland rejected them, and followed up his rejection, as we have seen, by the invasion of Belgium. The terms of the treaty which followed this invasion were much more favourable to Holland than those of the previous one; for the feeble resistance that Belgium had been able to make had affected very unfavourably the directing powers, who considered that, in the interests of the peace of Europe, their first duty was to strengthen the defensive power of Holland. The new proposals, therefore, caused great excitement in Belgium, and met with much opposition; but, eventually, they were adopted by a majority of 59 to 38 in the Chamber of Representatives, and 35 to 8 in the Senate.

The treaty was signed on 15th November, and its conditions were embraced in twenty-four articles. By these articles the grand-duchy of Luxembourg was to be divided, but the fortress of Luxembourg was to remain in the hands of the king of Holland as grand-duke, who was also to receive a portion of Limbourg for the part of Luxembourg ceded to Belgium. The district of Maastricht was also partitioned, the fortress of that name remaining with Holland; the Scheldt was to be open to the commerce of both countries, and the national debt was apportioned—to Belgium sixteen thirty-firsts, and the rest to Holland. It was also declared that Belgium "shall form an independent and perfectly neutral state."<sup>1</sup> This agreement was ratified by the Belgian and French sovereigns on the 20th and 24th November, by the British, 6th December; but the Austrian and Prussian sovereigns did not accede to it till 18th April 1832, and the Russian not till 4th May. The Dutch still continued to protest against it, and maintained their possession of Antwerp. After fruitless efforts on the part of the great powers to obtain their acquiescence, France and England resolved to have recourse to force. On the 5th November, therefore, their combined fleets sailed for the coast of Holland, and on the 18th, a French army, under the command of Marshal Gérard, crossed the Belgian frontier to besiege Antwerp. The garrison consisted of only about 5000 men, while the besieging force numbered 60,000. Operations commenced 30th November, and the siege in a military point of view is a memorable one. The garrison surrendered to the

French on 23d December, on the 31st the fortress was handed over to the Belgians, and some days afterwards the French troops recrossed the frontier. Long and complicated diplomatic negotiations followed, but matters were at length adjusted, and on the 21st of May 1833 a convention was agreed to and signed by all the parties. The House of Orange still numbered many partisans in Belgium, whose proceedings embarrassed the Government; and in Brussels, and some of the other towns, the people rose up against them, pillaging the houses of some of the leaders, and were appeased with difficulty. The king now gave his attention to the improvement of the manufactures and commerce of Belgium; and on 1st May 1834 he sanctioned the law which was to create the first railroad on the continent of Europe.

In 1835 the alien bill gave rise to considerable discussion, but it was at length carried. Its object was to give Government the power to send out of the kingdom, or to compel to reside in a particular place, any foreigner whose conduct was calculated to endanger the public peace. In 1836 an Act to regulate the municipal form of government in the towns and communes was passed. The election of the members of the municipal councils was continued in the citizens, but the appointment of the burgo-master and magistrates was vested in the king from among the members of the councils. The manufactures and commerce continued to flourish and extend, and the formation of railways was actively carried on. As Holland had not yet acceded to all the conditions of the twenty-four articles, Belgium still kept possession of the whole of Limbourg and Luxembourg except the fortress of the latter, with a small area round it, which was occupied by Prussian troops. These territories had been treated in every way as a part of Belgium, and had sent representatives to both chambers. Great indignation was therefore felt at the idea of their being separated, when Holland, on 14th of March 1838, signified its readiness to accept the conditions of the treaty. The chambers argued that Belgium had been induced to agree to the twenty-four articles in 1832 in the hope of thereby at once terminating all harassing disputes, but that as Holland did not then accept them, the conditions were no longer binding, and the circumstances were now quite changed. They urged that Luxembourg in effect formed an integral part of their territory, and that the people were totally opposed to a union with Holland. They offered to pay for the territory in dispute, but the treaty gave them no right of purchase, and the proposal was not entertained. The two chambers unanimously voted addresses to the king, expressing a hope that the integrity of Belgium would be maintained. Similar addresses were sent from all parts of the country, and the people were roused to a great state of excitement. The king was at one with his people, and every preparation was made for war. But the firmness of the allied powers, and their determination to uphold the conditions of the treaty, at last brought the king, though with extreme reluctance, to give in to their views. After violent discussions the Chamber of Representatives gave its adhesion on 19th March 1839, and some days later the Senate followed the example. The treaty was signed at London on the 19th of April. The annual payment by Belgium for its share of the national debt, which had been fixed at 8,400,000 florins, was reduced to 5,000,000 florins, or £416,666, with quitance of arrears prior to 1st January 1839. When this excitement was at its height the Bank of Brussels failed, and much misery and distress among the people was the result. This was immediately followed by the failure of the Brussels Savings-Bank, but the Government instantly came forward and guaranteed the claims thereupon, amounting to 1,500,000 florins.

<sup>1</sup> See Parliamentary paper, Aug. 1870.—*Netherlands, Belgium, and Luxembourg Treaties of 1831, 1839, and 1847.*

The Belgian revolution owed its success to the union of the Roman Catholics and the Liberals; and the king had been very careful to maintain the alliance between these two parties. This continued to be the character of the Government up to 1840, but by degrees it had been becoming more and more conservative, and was giving rise to dissatisfaction. A ministry was formed on more liberal principles, but it clashed with the Catholic aristocracy, who had the majority in the Senate. Disputes arose which caused great excitement among the people, and the cabinet resigned. A new ministry was then formed, under M. Nothomb, of a unionist or mixed kind. In 1842 a new law for the organization of public primary instruction was passed, which, however, did not meet with the approval of the clergy. In 1844 a commercial treaty was concluded with the German Zollverein; and soon after similar treaties were formed with France and Holland. The Nothomb ministry retired in 1845, and for seven months M. Van de Weyer attempted to carry on affairs with a mixed ministry; but he found it impossible to maintain harmony among the different factions. A Catholic administration was then formed, which was attacked with the greatest fury by the Liberals. The latter summoned a Liberal congress to meet at Brussels (14th June 1846), composed of delegates from the different Liberal associations throughout the country. Three hundred delegates met and deliberated with the greatest calmness, drawing up an Act of Federation and a programme of Belgian Liberalism. The elections of 1847 gave a majority in favour of the Liberals; the cabinet resigned, and a Liberal administration took its place and formally announced a new policy. Hence it happened that when next year France was in revolution and her king a fugitive, Belgium remained calm and unshaken. When the news reached Brussels the king convoked a council of his ministers and offered to resign if they thought that it would avert calamity or conduce to the public welfare. The ministers replied that a constitutional monarchy was best fitted for the people, and that a republic was neither according to their wishes nor adapted to their character. The democratic societies of Brussels attempted a revolutionary movement, but met with little success. At this time a new electoral law was issued lowering the franchise to 20 florins' worth of property (33s. 4d.), by which the number of electors was at once doubled; and soon after another law reduced the qualification for municipal councils to 46 francs (36s.) These timely concessions gave general satisfaction, and completely disarmed the extreme democratic party; so that when an expedition was organised in Paris against the throne of Leopold, with the countenance and aid of certain members of the French Government, it met with no sympathy and totally failed in its object. On the night of the 24th March the conspirators, to the number of about 800 French and 100 Belgians, arrived at Quivrain by train, but they were at once surrounded by the military and peasants and made prisoners. Alarmed at this attempt the Government strongly reinforced the frontier towns with troops, and was thus able to repulse a more formidable invasion that took place a few days later. Belgium, however, suffered severely from the shock given to commercial credit and general industry. The discounts at the bank, which in 1847 had been 160,200,000 francs, sank, in 1848, to 86,900,000 francs, and the current accounts fell from 183,000,000 francs to 96,000,000 francs. The panic soon rendered the payment of notes in cash impossible; and the Government, by a law passed 28th March 1848, suspended cash payments, and authorized the bank to issue inconvertible notes to a limited extent. By this reasonable measure public credit was restored, and industry speedily revived.

The attention of the Government was now largely

directed to the stimulating of private industry and the carrying out of public works of great practical utility, as the extension of railways and the coming up of other internal means of communication. Commercial treaties were also entered into with various countries with the view of providing additional outlets for industrial products. The king also sought as much as possible to remove from the domain of politics every irritating question, believing that a union of the different parties was most for the advantage of the state. In 1850 the question of middle class education was settled. In August of that year the whole country between Brussels and the French frontier suffered greatly from excessive rains; the country for many leagues was flooded, many lives were lost, and the destruction of property was very great. On 25th September the king laid the foundation stone of a monument in Brussels to commemorate the national congress which in 1831 had fashioned the new destinies of the country, and on 11th October the queen died. In 1852 the Liberal cabinet was overthrown, and a ministry of conciliation was formed. A bill was passed authorizing the army to be raised to 100,000 men including reserve. The elections of 1854 modified the parliamentary situation by increasing the strength of the Conservatives; the ministry resigned and a new one was formed under M. de Decker, of moderate Catholics and Progressives. At the Paris conference of 1856, which settled the peace with Russia, the French minister, Count Walewski, complained of Belgium permitting to issue from its press publications the most hostile and insulting to France and her government, in which revolt and assassination were openly advocated. The remarks caused great indignation in Belgium. In 1857 violent discussions took place between the Liberal party and the Roman Catholics on the question of the administration of charities throughout the kingdom. Since 1850 the administration of these had been vested in the secular power, and the Catholic party had long sought to get this power into their own hands. When, therefore, M. de Decker, who supported their views, became head of the ministry, the priests made every exertion, even by bribery, to influence the elections so as to obtain a majority in their favour. In April the ministry of M. de Decker brought in a bill practically abolishing the existing law on the subject. The bill met with the most violent opposition; the discussions, which extended over 27 sittings and were characterized by great animosity, revealed a growing spirit of exaction and intolerance on the part of the clergy; but eventually it was carried by a majority of 60 to 41. The result caused great excitement among the people, the Liberal deputies were cheered, and the principal Catholic speakers hooted and insulted. The agitation extended to the provinces, and the military had to be called out to restore peace. Eventually the bill was withdrawn, and the ministers gave in their resignations. The elections for the communal councils gave a great majority in all the important towns in favour of the Liberals. A new Liberal ministry was formed under M. Rogier. In 1860 the communal *octrois*, or the taxes on articles of food brought into the towns, were abolished; and in 1863 the navigation of the Scheldt was made free. This last year, also, a treaty of commerce and navigation was concluded with England. The elections of July 1864 gave a majority to the Liberals in the Chamber of Representatives, and the ministry of M. Rogier continued in office.

On the 10th December 1865 King Leopold died, after a reign of 34 years. He was greatly beloved by his people, and much respected by the other sovereigns of Europe. He was repeatedly chosen to decide in international disputes; and the grievances of hostile Governments were not unfrequently submitted to him. His well-known

honesty and integrity of purpose, his reflective and well-balanced intellect, his habit of close and accurate reasoning, his grave and serious deportment, all eminently fitted him for the office of arbiter. To him Belgium owed much. In difficult circumstances and critical times he managed its affairs with great tact and judgment; by conciliatory measures he reconciled and kept at peace opposing factions; and by his well-known devotion to the best interests of the country he secured the confidence and esteem of all classes of the people. He was succeeded by his eldest son Leopold II., who was immediately proclaimed king, and took the oath to the constitution on 17th December. In 1866 a body of English volunteers, to the number of 1100, visited Belgium by invitation, and met with a most cordial reception from the king and all classes of the people, and took part in the Tir National. The following year a body of Belgian volunteers, numbering about 2400, came over to England, where they were warmly welcomed, and engaged in the shooting contests at Wimbledon. In 1868 serious riots took place in the mining districts, which were not put down till the military had been called out; the effective army was raised from 80,000 to 100,000 men, and the yearly contingent from 10,000 to 12,000. Attempts were also made to obtain a revision of the elementary education law of 1842.

On the outbreak of the war between France and Germany in 1870, Belgium saw the difficulty and danger of her position, and lost no time in providing for contingencies. A large war credit was voted, the strength of the army was raised, and large detachments were moved to the frontier. The feeling of danger to Belgium also caused great excitement in England, particularly after the contents of the secret treaty—which revealed the aggrandising schemes of France against Belgium—became known. The British Government declared its intention to maintain the integrity of Belgium in accordance with the treaty of 1839, and it induced the two belligerent powers to sign treaties to that effect. In the event of either power violating the neutrality of Belgium, England was to co-operate with the other in such manner as might be mutually agreed upon to secure the integrity of the country. It was at first feared that Belgian territory might be violated by the necessities of one or other of the belligerents, but this was not the case. A considerable portion of the French army routed at Sedan did, indeed, take refuge in Belgian territory; but they laid down their arms according to convention, and were "interned" in the king's dominions.

In 1870 the Liberal party, who had been in power for thirteen years, was overthrown by a union of the Catholics with the Radicals or Progressionists, joined by not a few Liberals, to whom the opposition of the Government to certain reforms had given offence. A ministerial crisis followed, which was terminated by the advent to office of a Catholic cabinet, at the head of which was Baron d'Anethan. A new election took place in August 1870, which gave them a majority in both houses,—a result brought about in no small degree by the excitement consequent on the breaking out of the Franco-German war. The Baron

d'Anethan steered his course prudently, and increased the power of the Ultramontanes considerably by carrying a reform bill, which widened the basis of representation as regarded the provincial and communal councils, by introducing large masses of the Catholic lower orders to the privilege of the franchise. It added nearly one-half to the number of electors for the provincial councils, and more than a fourth to those for the communal councils. The Liberals were very much dissatisfied; and towards the end of the year the mob in Brussels took up the question, and tumults broke out which the police and civil guard had to put down by force. They demanded the dismissal of the ministers, to which the king at length consented; and a new ministry was formed under M. de Theux. The communal elections of 1872 were the occasion of a sharp struggle throughout the kingdom between the church party and the Liberals, but success remained chiefly with the latter. The elections of June 1874 resulted in a considerable reduction of the Ultramontane majority within the Senate and the Chamber of Representatives, without actually converting it into a minority. In July of that year a conference of representatives of the leading powers of Europe was held in Brussels, with the view of introducing certain changes in the usages of war, but no definite result was arrived at. In May and June 1875, religious disturbances broke out in various parts, which were attended with serious consequences. At Brussels, Ghent, and other places, religious processions, which partook of the character of party demonstrations, were attacked by mobs of the populace, and many persons were injured. These disturbances were only put a stop to by energetic measures on the part of those in authority, and the infliction of severe punishments on the delinquents.

The attention of foreign states has of late been particularly directed to Belgium, in consequence of certain remonstrances addressed to it by Germany on the subject of its international relations and its duties towards foreign powers. This arose from an obscure Belgian, named Duchesne, having written to a French archbishop, offering to assassinate Prince Bismarck for a consideration. He was taken and tried by the Belgian Government, but it was found that the law had provided no punishment for the offence which he had committed. This led to a remonstrance on the part of the German Government, which was couched in such terms as to afford ground for the gravest fears, on the part of Belgium and of foreign states, as to what might be the result. The correspondence, however, was carried on in a friendly spirit on both sides, satisfactory explanations followed, and the Belgian Government passed a measure making such offences as that of Duchesne criminal.

See Alison's *History of Europe*; *The Belgian Revolution of 1830*, by C. White, 2 vols., 1836; *Belgium and the Twenty-four Articles*, by C. White, 1838; *Histoire de la Belgique*, by Theodore Juste, 2 vols. 4to, 1858; *La Revolution Belge de 1830*, by Th. Juste, 2 vols., 1872; *Memoirs of Leopold I.*, by Th. Juste, 2 vols., London, 1868; *Napoleon III et la Belgique*, by Th. Juste, 1870; *Memoirs of Van de Weyer*, by Th. Juste, 2 vols., 1871; *The Annual Register* for various years; *Annuaire Statistique de la Belgique*, 1874; *Almanach Royal de Belgique*, 1875. (D. K.)

**BELGRADE** (in Servian, *Bielgorod*, or White Town), the capital of the Servian principality, situated at the confluence of the Save and the Danube, on the right bank of the latter stream, opposite the Austrian town and fortress of Semlin. Lat. 44° 47' N., long. 20° 28' E. It is built both on, and at the side of, a northern spur of the Avala heights, the rocky summit being crowned by its once famous citadel, which still remains very much as it

was left by Prince Eugene, except that on the E., S., and W. the glacis has been changed into a promenade. The town was formerly divided into three parts, namely, the Old Town, the Russian Town (*Sava mahala* or Save-district), and the Turkish town (*Dorcol*, or Cross-road). A great change has, however, taken place in the course of the present century, and the old divisions are only partially applicable, while there has to be added the

Tirasia, an important recent suburban extension along the line of the aqueduct or *Tirazi*. Since 1869 great activity has been shown in building, and the Old Town is gradually being regulated according to a definite plan. The general appearance of the place is growing more and more European; its mosques and minarets, protected from actual demolition by a Turkish treaty, are falling into ruin from neglect. As the seat of the Servian Government, and the residence of the prince and the archbishop, Belgrade possesses a royal and an episcopal palace, a foreign and a home office, and other public buildings. Its educational institutions are remarkably numerous, consisting of a high school, several normal schools, a gymnasium, a theological seminary, a military academy, an industrial school, and an upper school for girls. There is a theatre devoted to the development of the national drama; and in the same building with the high school there is preserved a valuable collection of national antiquities as well as an extensive library. Besides the mosques, the ecclesiastical buildings include a cathedral and several Greek churches, a Roman Catholic chapel in the Austrian embassy, and an evangelical church. Among places of historical interest are the ruins of Prince Eugene's palace, and the monument in the Topjiders park on the spot where Prince Michael was assassinated in 1868. The citadel has been already mentioned; a commandant's residence, barracks, and a military hospital are among its subsidiary buildings. Though its situation is highly conducive to mercantile activity, the commerce of Belgrade is not so great as would naturally be anticipated. It holds, however, direct commercial relations not only with Vienna and Constantinople but with Manchester. There are only two monetary establishments, one known as the "First Bank," and the other a bank of credit. The principal industrial products of the city are cotton-stuffs, carpets, leather, and fire-arms. Belgrade is identified with the ancient *Singidunum*, and was the station of the *Legio IV. Flavia Felix*. It has from its earliest existence been a place of military importance, and in modern times has sustained many sieges, and repeatedly passed from the hands of the Austrians to those of the Turks. It was taken by Soliman II. in 1521, and retaken by the Austrians in 1688, but again lost in 1690. In 1717 it surrendered to Prince Eugene. The imperialists retained it till 1739, when the Turks invested and reduced it. Austria again took it in 1789, but it was restored at the peace of 1791. In the year 1806 the Servian insurgents succeeded in carrying it. In 1862 it was bombarded from the citadel on account of a contest raging between the Turkish and Servian inhabitants, but five years later it was completely evacuated by the foreign forces, and the citadel received a garrison of Servian soldiers. The only mark of Turkish occupation is the banner which continues to be shown from its walls along with the national colours. Population in 1872, 26,674.

**BELIEF** (*niros, Fides, Foi, Glaube*), with its synonyms Assurance, Confidence, Conviction, Credence, Trust, Persuasion, Faith, is in popular language taken to mean the acceptance of something as true which is not known to be true, the mental attitude being a conviction that is not so strong as certainty, but is stronger than mere opinion. For the grounds of such conviction, ordinary language refers at once to probable as opposed to intuitive or demonstrative evidence. Such popular phrases do not, of course, amount to a definition of belief; but this is not to be expected from them, especially if, as may be laid down with some confidence, no logical definition of the process be possible. It may be described and marked off from similar or contrasted states, but a rigidly scientific definition of what appears to be a simple, ultimate fact is not attainable. The general explanation, however, is so far

unsatisfactory in that it throws no light upon the most interesting question with regard to belief, its province, and does not tell us what are the objects of belief as opposed to those of knowledge. To answer this it is necessary to describe somewhat more minutely the mental process under examination.

1. Unfortunately for purposes of analysis, the word belief is used in a variety of relations which seem at first sight to have but little in common. We are said to believe in what lies beyond the limits of our temporal experience, in the supersensible, in God and a future life. Again, we are said to believe in the first principles or ultimate verities from which all trains of demonstration must start; as conditions of demonstration, these are themselves indemonstrable, and are therefore objects of belief.<sup>1</sup> We receive by belief perceptions of single matters of fact, which from their very nature cannot be demonstrated.<sup>2</sup> We believe from memory the facts of past experiences; we have expectation or belief in future events. We accept truths on the evidence of testimony; and finally, we believe that our actual consciousness of things is in harmony with reality. From this unsystematic arrangement of objects of belief it will be possible to eliminate certain classes by noting in the first instance what we are not said to believe, but to know. By knowledge may be understood generally the conviction of truth which rests on grounds valid for all intelligence, and which is expressed in propositions necessary both for our thinking and for reality. At the same time we are commonly and correctly said to know states of consciousness when they are immediately present, together with their differences, similarities, connections, and relations to self. Whatever is necessarily connected with present experience, and can be logically deduced from it, is also matter not of belief but of knowledge. Again, we know all propositions of apodictic certainty, such as those of mathematics and logic. Mathematical propositions carry us beyond mere thinking; the laws which flow from the relations of space and time are not only thought but known to be true of all objects of sensible experience, for no objects whatsoever can form part of that experience save under these quantitative conditions. It is therefore an error to say that we believe abstract mathematical laws apply to objects; we know this with absolute certainty. So also our cognizance of logical principles, such as the laws of identity and contradiction, is matter of knowledge, of insight, not of belief. It would appear, therefore, that knowledge extends to facts immediately present in consciousness, and to certain relations true of all facts of sensible experience; but in neither of these classes of cognition does there seem to be given an absolute guarantee for the existence of any fact which is not immediately before us. That one object presented to us is known seems to give no actual knowledge that another object ideally connected with it has at the same time real being. Mathematical and logical laws are absolutely true of all experience to which they apply, but this truth gives no certainty that there will be experience. If there be objects of experience at all, they must be subject to mathematical and logical law; but the question remains, is there any ground, absolutely necessary and compelling assent, for holding that there will be such experience.<sup>3</sup> This is an old matter of debate; it lies at

<sup>1</sup> This has been pointed out by a long line of thinkers, from Aristotle to Jacob and Hamilton.

<sup>2</sup> So knowledge through the senses is called *Offenbarung* by Jacob and Lotze (*Mikrokosmos*, iii. 543).

<sup>3</sup> Cf. Lotze, *Mik.*, iii. 547. "When one affirms that every object of thought is identical with itself, that the same under the same conditions has the same consequences, under different conditions different consequences, that a cause precedes every effect, — all these are universal truths, which tell us, indeed, what must be or take place if there should



the very root of the distinction between knowledge and philosophical belief, and leads directly into the deepest problems of metaphysical science, its solution depending upon the answer given to the doubt whether or not our thinking is merely formal, receiving materials and working them up in forms which may have no correlates in reality. Hume, who in this connection has given the impulse to all subsequent British thinking, laid his finger with unerring precision on the crucial point, and deliberately relegated all matters of fact to the province of belief. According to him, knowledge never passes beyond immediate intuition of ideas and their relations. Whenever we touch upon real existence, past or future, belief, not knowledge, is our instrument. An adequate discussion of the difficulty would lead beyond the limits of the present inquiry; it may suffice to indicate generally what can be said on one typical point of the debate. Is the supposition of a causal connection among phenomena merely belief, or is it a necessary condition of knowledge? If the latter, then our thinking carries us with apodictic certainty beyond present experience of facts, for every causal judgment is, *ipso facto*, universal, and therefore extends to all or any time. Now, no proof of the universality of law among phenomena can ever be given from empirical grounds, for all such attempts virtually involve the very principle in question. It is a necessary presupposition, without which knowledge would be impossible. Its contrary is certainly not self-contradictory, if by self-contradiction be meant impossibility of representation, for chaos can be pictured; but the power of imagination is surely not the criterion of truth. It is the power of knowing objects that is in question, and the non-existence of the causal relation among phenomena would render actual experience impossible. Objects cannot be known save under this supposition. A similar line of argument directed towards others of the notions involved in what Kant has called synthetical judgments *a priori*, would show that such notions are constitutive of our experience, that thought penetrates deeply into phenomena, and that phenomenal relations are but types of the forms of real cognition. It might, of course, still be maintained that all these synthetical propositions are only formal,—are only true if experience be given,—and that a wide field is still left for belief. Under certain conditions this may be admitted. A doubt as to the very existence of experience is hardly a valid argument, but that there should be specific connections of phenomena, permanent and constant—that, for example, the same cause should continue to have the same effects—may seem not quite a matter of knowledge. The real element of doubt in such a case is not, however, whether the same cause under the same conditions shall give the same effects, but whether in any definite instance we have attained a thorough knowledge of the cause itself, and whether the conditions will recur. The first of these doubts is overcome in the ordinary progress of knowledge; the other concerns the empirical appearance of the effects, relates therefore to what may be called the contingent, and forms the object of belief.

It follows from what has been said that we exclude from the province of belief primitive truths and facts of immediate experience, with such phenomena, past or future, as are connected causally or by rational links with facts immediately known. There is still a wide field left for belief. (a.) In the stage of knowledge which we call sensible cognition belief introduces itself; for consciousness, which unhesitatingly affirms the correspondence of its content with reality, readily exhibits its falsity when submitted to analysis. The belief, though firm, is shown to

be erroneous,—to be merely the rapid summation of a number of signs, which themselves do not come clearly before consciousness, and are therefore accepted without examination. (b.) In memory of our own past experience belief is involved. When I remember, I have present to consciousness ideas which represent past reality. To have ideas simply is to imagine; to have ideas which we are convinced represent past experience is to have imagination *plus* belief, i.e., to remember. It should be observed that we are frequently said to trust our memory, to believe that what we remember is true. This phraseology is objectionable; we cannot properly be said to trust our memory, we simply use it. In the very fact of remembering is involved the reference to past reality which is the essence of belief. (c.) We believe testimony, i.e., we accept as true facts not in our experience, and which possibly may never be. In this case our belief is, that under certain conditions we should have the experience which from the testimony we can picture to ourselves. (d.) Expectation, so far as merely contingent elements are concerned, is a pure case of belief.

2. So far as we have yet seen, all objects of belief have been or may be objects of knowledge; and the most prominent distinction between the two is the presence in the one of an actual intuition and its absence in the other. This distinction, however, as we have pointed out, is not absolute; all thinking of reality is not belief. Belief is rather the thinking of reality which is determined by grounds not necessarily valid for all intelligence, but satisfactory for the individual thinker. The difference between imagination and the thought of some reality does not seem capable of further analysis; it expresses an ultimate fact. Attempts, however, have been made to work out a psychology of belief, and to point out the characteristics differentiating ideas believed in from mere pictures of the mind. These have been generally due to British thinkers; and, since the time of Hume, the problem has become one of considerable importance. Locke, who marked out very carefully the province of belief and considered its grounds, made no attempt to analyze the state itself. Hume,<sup>1</sup> however, puts the question clearly before himself and returns an unhesitating answer. "As it is certain," he says, "there is a great difference betwixt the simple conception of the existence of an object and the belief of it, and as this difference lies not in the parts or composition of the idea which we conceive, it follows that it must be in the manner in which we conceive it. When we are convinced of any matter of fact, we do nothing but conceive it along with a certain feeling, different from what attends the reveries of imagination." "This feeling is nothing but a firmer conception or a faster hold that we take of the object." "This manner of conception arises from a customary conjunction of the object with something present to the memory or senses." From the last sentence to the elaborate theory of James Mill is but a short step. According to Mill, belief is a case of constant association; an idea is believed which is irresistibly called up in connection with present experience. Thus in memory, the ideas of the past experience are irresistibly associated with the idea of myself experiencing them, and this irresistibility constitutes belief. Expectation, again, is the irresistible suggestion by present experience of a consequent or train of consequents. And to memory and expectation all ordinary cases of belief may be reduced.

Both these theories are defective in the same point,—the analysis of what is meant by object in general, and, consequently, of what is involved in thinking of an object. Hume's is open to the special objection that he makes the

be a case of their application, but which tell us nothing of the real existence of any case.

<sup>1</sup> A theory somewhat similar to that of Hume is worked out by Mr. Bagshot, *Contemporary Review*, April 1871.

difference between the believed and imagined idea the same as that between impression and idea, which is an ultimate distinction, and yet holds the difference to be merely one of degree. In Mill's account of memory it may be pointed out that the ideas of *past* experience, and of myself as having had the experience, contain in themselves the very element which is supposed to be got out of their conjunction. With regard to expectation it is clear that ideas irresistibly suggested by present experience are by no means necessarily believed, and further, that many of our beliefs do not arise from any such association. J. S. Mill,<sup>1</sup> who subjects the association theory of belief to a searching examination, comes to the conclusion that the distinction between thinking of a reality and representing to ourselves an imaginary picture is ultimate and primordial. With his opinion later investigators, as Mr Sully,<sup>2</sup> concur.

Professor Bain, in opposition to other psychologists, holds that belief is not so much an intellectual state as a "phase of our active nature, otherwise called the will." "It is a growth or development of the will under the pursuit of intermediate ends." When, for instance, we perform certain acts as means towards a desired end with as much vigour as if we were realizing the end itself, "we are in a very peculiar situation, not implied in desire." This situation is belief, which is essentially "an anticipation of the pleasure" of attaining the end. Belief being a form of activity, our primitive state is one of complete confidence. The mind is filled with its present experience, and confidently believes that the future will resemble it. Ideas are so strongly taken up by the mind that they are accepted as real, and influence the will. The various disappointments of this primitive confidence give rise to definite avoidances of certain actions, and to pursuit of others, in order to escape pain or gain pleasure. Action directed towards these intermediate ends involves, or rather is, belief. This theory has to explain expectation and memory. With regard to the first, "we make light of the difference between the conceived future and the real present;" or in other words, "we are disposed to act in any direction where we have never been checked." Our primitive disposition to act is equivalent to full expectation. It may be pointed out that this explanation throws no light on expectation of events in which our activity could by no possibility be involved. But the theory seems to break down entirely when applied to memory. There is first to be explained the fact of memory, and then it has to be shown how reference to activity is contained in it. "In surrendering our mind to the idea still remaining, and so imparting a momentary quasi-reality, we have an experience possessing the characteristic features of present reality." "We really make no radical difference between a present and a proximate past." This, in the first place, would apply only to certain cases of memory. Secondly, imparting a quasi-reality is not an explanation of the peculiar phenomenon of an idea representing the past. It is an error, even on Professor Bain's own principles (see note to *Mill's Analysis*, i. 342; *Emotions and Will*, 2d ed. 525), to speak of belief in a present reality, while here memory is explained as a pseudo-realization of the ideas. Nor is he more successful in referring memory to activity. To identify my remembrance of having run up against a wall to avoid a carriage with the conviction that, should such a danger recur, I should again run up against the wall (see *Emotions and Will*, 2d. ed., 554), is absurd. The whole theory seems but an instance of a not uncommon error in psychology,—the confusion of the test or measure of a thing with the thing itself. Belief is truly a motive to action,<sup>3</sup> and all

that has been said of it by Professor Bain would hold good of it in this relation; to identify the two is to run together totally distinct processes.

Modern German psychology has not approached the problem of belief from the same side as the English. Benet alone, by his analysis of *tact* (see *Lehrbuch der Psych.*, § 158, and *System der Logik*, i. 268, seq.), has opened up a somewhat fresh vein of thinking. His hints have been carried out by Germer (*Die alte Streitfrage, Glauben oder Wissen*, 1856), who gives the following definition of belief: "If the consciousness (of the truth of what we think) arises from *tact*, and therefore without consciousness of the factors or grounds through which it is produced, it is called belief; it is elevated to knowledge when these factors are brought before consciousness" (p. 58).<sup>4</sup> In general the example of Kant has been followed, who looked upon the question as belonging not so much to psychology as to the theory of knowledge. His own discussion of the subject and his distinction between *Meinen*, *Glauben*, and *Wissen* have powerfully influenced later thought. According to him, *Glaube* (belief, in the sense of *Fides* as opposed to *Credulitas*, *Foi* as opposed to *Orogance*) should be confined to such propositions as rest on grounds subjectively not merely sufficient but necessary; that is to say, the propositions believed in are recognized as the demands of our moral or practical reason, and their truth can never be disproved, for such disproof would be radically inconsistent with the moral nature which we are conscious of possessing. Our confidence in their truth is unwavering and practical, i.e., leading to action; for without them we could not act in conformity with our moral nature. Nevertheless, of the objects of such propositions we can never have scientific knowledge.

3. Kant's distinction of *Meinung* and *Glaube* leads us directly to the one species of belief which has not yet been considered. All objects of belief, so far as has yet appeared, might come within our temporal experience; but we are said to believe in the supersensible, which from its very definition seems to surpass experience and, consequently, knowledge. To such belief the name *faith* is properly restricted, and in its nature it differs somewhat from the belief hitherto discussed. There is not, of course, included in it the specifically theological notion of faith as *Fiducia* (*quæ est apprehensio meritis caritative appropriativa ad se et se in individuo*); it corresponds rather to the *Notitia* and *Assensus*, which are also elements in the theological faith, and may be defined as the subjective expression of man's relation to God. When understood in this sense, religious belief is by no means a mere feeling, though it contains feeling as one of the stages in its development, for mere feeling is in itself blind and valueless, whereas faith is intelligent or rational. Nor is it a blank faith which would have the same value whatever were the objects believed in, for religious belief has a definite content; it is the acceptance of certain facts and truths and the active realization of them. As its content is definite (for if it were not so, the religions of Christ and of Mahomet, of Buddha and of Zoroaster, would stand on the same level, all having subjective faith or conviction), belief of necessity involves knowledge, rational construction of the facts believed. Faith is but the lower stage of completed insight, and in its own development follows the natural order of progress in knowledge, which begins with feeling and intuition, rises through concrete representation into logical connection,

great difficulty in reconciling his theory with ordinary phraseology. Such an expression as the following has a curious ring:—"Belief is identical with the activity or active disposition, at the moment, and with reference to the thing believed."—(Note to *Analysis*, i. 336.)

<sup>4</sup> With this view may be compared much of what is said by J. E. Newman, *Grammar of Assent*; see especially 73, 261.

<sup>1</sup> Notes to J. Mill's *Analysis*, i. Cf. *Discussions*, iii.

<sup>2</sup> *Sensation and Intuition*. (On the Development of Belief.)

<sup>3</sup> It is so defined by Bain (*Ment. and Moral Sc.*, 373), who finds

and finally culminates in rational cognition. So religious belief, which is primarily little more than a vague feeling of something over and beyond the present state of existence, combined with the dim sense of our own finite and dependent condition, gradually rises to a higher stage, and in its efforts to attain some cognizance of the supersensible, begins even to attach itself to natural objects. But as it can find in these no satisfaction, it is compelled to construct some representations of the supernatural which shall harmonize with our spiritual wants. In the formation of these religious ideas we are not left without help, nor are they to be looked upon as mere figments of the mind. The revelation which has been given in nature, both physical and moral, and in the special experience to which the name is more frequently applied, furnishes matter which is laid hold of and pressed into the service. Religious belief or faith always attaches itself to representations, intuitions, or facts; it gives what Newman has called Real as opposed to Notional Assent. But it is not the less necessary that faith should be raised to insight, and that we should construe in terms of thought what religious experience brings before us as direct intuition. There must be theology as well as religion. Nothing is believed which is not held to be so connected with the rational nature of man as irrevocably to injure that nature should its truth be overthrown. This is not to put knowledge in place of faith, if knowledge be understood to apply only to the logically necessary; nor is it to assert that what have been called truths of revelation could have been discovered by natural reason. Knowledge, however, cannot be confined to the abstract understanding; and nothing is more delusive than the total opposition of revelation and reason. "What is there in the nature of things," says Augustine, "that God has done unreasonably?" To affirm that reason does not of itself discover the truths of revelation, is simply to bring against it the reproach it may well bear, that it does not create experience. Reason has not to make new facts, but to accept given experience, and evolve from it the pure elements of thought which it contains; and in which its truth consists. Faith, therefore, precedes knowledge, as Anselm used to say; but its priority is that of time, not of authority.<sup>1</sup>

4. There remains to be taken into account the interesting question of the grounds and motives for belief. It is, of course, necessary to distinguish between these two; the cause of a belief may not be exactly a reason for it. Belief, though natural, is not always rational, but frequently rests with happy unconsciousness on foundations utterly inadequate to its support. But if we disregard this distinction and include both causes and reasons under the title principles of belief, these may be divided into three classes—(1), Testimony; (2), Feelings, Desires, or Wishes; (3), Evidence of Reason. These are rarely discovered in actual practice. Testimony, to the reception of which the name belief is frequently restricted, is familiar enough to require no extended notice. Our natural tendency is to accept all testimony as true; it is experience alone that teaches caution. Where from the nature of the case no such experience is to be had, credulity settles down into firm and ineradicable conviction. The majority of men would be astonished to find how much their belief depends upon the society into which they have been born and in which they live. Dogmas at first forced upon a people gradually become ingrained in the minds of those brought up in habitual contact with them. There is hardly a limit to the possibility of instilling beliefs through continued custom, and no resistance to analysis is so strong as that offered by mere customary opinion, which has impercep-

tibly introduced itself into the very life's blood of those who share it.

The feelings, though not so directly a source of convictions as testimony, exercise an extensive and complex influence on belief. It has always been a popular saying that a man believes what he wishes—that "the wish is father to the thought;" and there can be no doubt that the superior force given to an idea by the concentration on it of desire or affection, causes it to bulk so largely in consciousness as to exclude the thought of its non-realization. The very idea of a result opposed to what we earnestly desire is unpleasant enough to make us resolutely shut it out of sight. This, however, is but a partial and limited effect. We know very well that our belief is only occasionally swayed by our wishes, and that necessity too often constrains us to believe what we willingly would not. Our volition cannot directly compel belief. But the feelings play a more important part; for it is by their means primarily that we stretch beyond the field of direct knowledge and complete our limited experience with what we feel to be necessary for the harmony of our moral and religious nature. We believe that without which our nature would be dissatisfied, and this belief takes its rise in the feelings,—the blind expressions of intellectual want,—which form the first stage towards completed insight.

It is hardly necessary to do more than refer to the rational grounds for belief. Wherever our knowledge of any object or law is incomplete, belief is ready to step in and fill up the gap by some hypothesis, which is in conformity with our experience, is rationally connected with the facts to be explained, and is not yet known to be true. Great portions of our so-called scientific knowledge are nothing but rational belief,—hypotheses unverified, perhaps even unverifiable,—and the settlement of the conditions or legitimacy of such presumptions forms the principal part of inductive logic.

Besides the works already referred to, the following treat of belief in general:—Fechner, *Drei Notizen und Gründe des Glaubens*, 1868; Uhlir, *Glauben und Wissen, Epistemologie und exacte Wissenschaft*, 1858; of religious belief in particular, in addition to works on dogmatic-theology or philosophy of religion:—Schwarz, *Das Wesen der Religion*, 1847; Auber, *Der religiöse Glaube*, 1860; J. Kuetlin, *Der Glaube*, 1860; Venn, *Bampton Lectures for 1869*. (R. AD.)

**BELISARIUS** (Solovonic, *Beli-tar*, "White-Prince"), the greatest general of the Byzantine empire, was born about 505 A.D., at Germana, on the borders of Illyria. As a youth he served in the body-guard of Justinian, who appointed him commander of the Eastern army. He won a signal victory over the Persians in 530, and successfully conducted a campaign against them, until forced, by the rashness of his soldiers, to join battle and suffer defeat in the following year. Recalled to Constantinople, he married Antonina, a profligate, daring woman. During the sedition of the "green" and "blue" parties of the circus he did Justinian good service, effectually crushing the rebels who had proclaimed Hypatius emperor. In 533 the command of the expedition against the Vandal kingdom in Africa, a perilous office, which the rest of the imperial generals shunned, was conferred on Belisarius. With 15,000 mercenaries, whom he had to train into Roman discipline, he took Carthage, defeated Gelimer the Vandal king, and carried him captive, in 534, to grace the first triumph witnessed in Constantinople. In reward for these services Belisarius was invested with the consular dignity, and medals were struck in his honour. At this time the Ostrogothic kingdom, founded in Italy by Theodoric the Great, was shaken by internal dissensions, of which Justinian resolved to avail himself. Accordingly, Belisarius invaded Sicily; and, after storming Naples and defending Rome for a year against almost the entire strength of the Goths in Italy, he concluded the war by the capture of

<sup>1</sup> See SCOTUS ERIGENA, *De Divis. Natur.*, l. 49.

Ravenna, and with it of the Gothic king Vitiges. So conspicuous were Belisarius's heroism and military skill that the Ostrogoths offered to acknowledge him Emperor of the West. But his loyalty did not waver; he rejected the proposal and returned to Constantinople in 540. Next year he was sent to check the Persian king Nushirvan; but, thwarted by the turbulence of his troops, he achieved no decisive result. On his return to Constantinople the intrigues of Antonina, whom he had confined on account of her illicit amours, caused him to be stripped of his dignities and condemned to death, and he was only pardoned by humbling himself before his imperious consort. The Goths having meanwhile reconquered Italy, Belisarius was despatched with utterly inadequate forces to oppose them. Nevertheless, during five campaigns his strategic skill enabled him to hold his enemies at bay, until he was removed from the command, and the conclusion of the war entrusted to his rival Narses. Belisarius remained at Constantinople in tranquil retirement until 559, when an incursion of Bulgarian savages spread a panic through the metropolis, and men's eyes were once more turned towards the neglected veteran, who placed himself at the head of a mixed multitude of peasants and soldiers, and repelled the barbarians with his wonted courage and adroitness. But this, like his former victories, stimulated Justinian's envy. The saviour of his country was coldly received and left unrewarded by his suspicious sovereign. Shortly afterwards Belisarius was accused of complicity in a conspiracy against the emperor; his fortune was confiscated, and himself flung into prison. His last years are shrouded in uncertainty, as they are not dealt with in the circumstantial history of Procopius; but he seems to have been liberated and reinstalled in the enjoyment of his hard-won honours before his death in 565. The fiction of Belisarius wandering as a blind beggar through the streets of Constantinople, which has been adopted by Marmontel in his *Belisaire*, and by various painters and poets, seems to have been invented by Tzetzes, a writer of the 12th century. Gibbon justly calls Belisarius the Africanus of New Rome. But for his successes, which were achieved with most insignificant means, the effete Byzantine empire would have been dismembered among Vandals, Persians, and Goths. He was merciful as a conqueror, stern as a disciplinarian, enterprising and wary as a general; while his courage, loyalty, and forbearance seem to have been almost unswerving. Like Corbulo, the faithful general of Nero, he was suspected and persecuted by an ungrateful master; and, like him, he restored the old discipline to the troops and the ancient lustre to the Roman arms in a corrupt and nerveless age. (Cf. Mahon's *Life of Belisarius*; Finlay's *Greece under the Romans*; Procopius; Gibbon's *Decline and Fall*, ch. 41-43.)

**BELIZE**, the capital of British Honduras, and the only trading-port in the colony. It is situated on the sea-coast, at the mouth of a river of the same name, in lat. 17° 29' N. and long. 88° 8' W. It consists of one principal street along the shore with a number of offshoots, is for the most part well built, and has a governor's house, a fort, a court-house, a jail, a Gothic church, a hospital, and a number of schools. The exports are principally mahogany, rose-wood, cedar, logwood, cocoa-nuts, fustic, and sugar. In 1872, 379 vessels, most of them British, with a total tonnage of 32,345 tons, entered the port. Regular steamboat communication has been established with Kingston, Jamaica. The population is about 5000.

**BELKNAP, JEREMY**, an American clergyman and author, was born at Boston in 1744 and died in 1798. He was educated at Harvard University, where he graduated in 1762. In 1767 he was called to a Congregational church in Dover, New Hampshire, and remained there for twenty years. He then removed to the Federal

Street church in Boston, which he held till his death. His principal works are—*History of New Hampshire*, 3 vols., 1784-92; *American Biography*, 2 vols., 1794-98; *The Foresters*, 1792.

**BELL** (from Ang. Sax. *bellan*, to resound, akin to *peal*), an open percussion instrument varying in shape and material, but usually cup-like or globular and metallic, so constructed as to yield one dominant note. This definition excludes on the score of sound the cauldrons of Dodona (*Dodonai labets* of the Greek oracular temple), and also the Chinese or Indian gongs, and, on the score of shape, all drums, cymbals, the metal plates of the Romans, and resonant bars of metal or wood still used by many savage tribes.

Antiquaries have worried themselves and their readers about the antiquity of bells and to small purpose. It is doubtful whether the bells of gold (Exod. xxviii. 32, 35) were anything but jangling ornaments of some kind worn by the high priest; but Mr. Layard believes that he has found some small bronze bells in the palace of Nimroud. We may gather generally that small bells long preceded large ones, which latter, however, were used in India and China long before they were known in Europe.

The Romans used bells for various purposes. Lucian, 180 A.D., mentions an instrument (*Clepsydra*) mechanically constructed with water, which rang a bell as the water flowed to measure time. Bells summoned the Romans to the public baths; they were also used in processions, and so passed naturally into the service of the Western Church. The first recorded application of them to churches is ascribed by Polydore Vergil to Paulinus (circa 400 A.D.). He was bishop of Nola, a city of Campania (hence *nola* and *cassepama*, the names of certain bells). It has been maintained that Pope Sabinianus, 604, first used church bells; but it seems clear that they were introduced into France as early as 550. In 680 Benedict, abbot of Wearmouth, imported them from Italy; and in the 7th century, Bede mentions them in England. St. Dunstan hung many in the 10th century; and in the 11th they were not uncommon in Switzerland and Germany. It is incredible that the Greek Christians, as has been asserted, were unacquainted with bells till the 9th century; but it is certain that, for political reasons after the taking of Constantinople by the Turks, in 1453, their use was forbidden, lest they should provide a popular signal for revolt.

Several old bells are extant in Scotland, Ireland, and Wales; the oldest are often quadrangular, made of thin iron plates hammered and rivetted together. Dr. Reeves of Lusk described in 1850 St. Patrick's bell preserved at Belfast, called *Olog an eadhachta Phatruic*, "the bell of St. Patrick's will." It is 6 inches high, 5 broad, 4 deep, adorned with gems and gold and silver filigree-work; it is inscribed 1091 and 1106, but is probably alluded to in Ulster annals in 552. For Scotch bells, see *Illustrated Catalogue of Archaeological Museum*, Edinburgh, for 1856.

The four-sided bell of the Irish missionary St. Gall, 646, is preserved at the monastery of St. Gall, Switzerland. In these early times bells were usually small; even in the 11th century a bell presented to the church at Orleans weighing 2600 lb was thought large. In the 13th century larger bells were cast. The bell, Jacqueline of Paris, cast 1400, weighed 15,000 lb; another Paris bell of 1472, 25,000 lb; and the famous Amiens bell at Rouen, 1501, 36,364 lb. But there we have reached the threshold of the golden age of bells, of which more anon.

Before we enter on the history and manufacture of the bell in Europe it is worth while to enumerate the different kinds of bells named by Hieronymus Maginus in his work *De Trinitatibus*:—1. *Trinitatibus*, a little bell, otherwise called *sinaculum*, for refectory or dormitory, according to Beletius, but Durandus names *agullâ* for the

refectory; 2. *Petarius*, or larger "broad-brimmed hat" bell; 3. *Codon*, orifice of trumpet, a Greek hand-bell; 4. *Nola* (see *ante*), a very small bell, used in the choir, according to Durandus; 5. *Campana* (see *ante*), a large bell, first used in the Latin churches in the steeple (Durandus), in the tower (Belethus); 6. *Squilla*, a shrill little bell. We read of *cymbalum* for the cloister (Durandus), or *campanella* for the cloister (Belethus); *notula* or *dupla* in the clock; *signum* in the tower. There was also a bell called *corrigiuncula*, to summon the monks at scourging time.

We shall now give a brief account of the manufacture of the bell proper, i.e., the church bell of the last five centuries. It must not be supposed that the early bell-founders understood all the principles of construction, mixture of metals, lines, and proportions which go to form our notion of a good bell. As the Amati or Stradivarius violin is the result of innumerable experiments extending over centuries, so the bells of Van den Gheyn (1650) and Hemony (1650) disengaged themselves after ages of empirical trials as the true models, and supplied the finished type for all succeeding bell-workers.

Bell-metal is a mixture of copper and tin in the proportion of 4 to 1. In Henry III.'s reign it was 2 to 1. In Mr Leyard's Nineveh bronze bells, it was 10 to 1. Zinc and lead are used in small bells. The thickness of the bell's edge is 1.15th of its diameter, and its height is twelve times its thickness.

Bells, like viols, have been made of every conceivable shape within certain limits. The long narrow bell, the quadrangular, and the mitre-shaped in Europe at least indicate antiquity, and the graceful curved-inwardly-midway and full trumpet-mouthed bell indicates an age not earlier than the 16th century.

The bell is first designed on paper according to the scale of measurement. Then the crook is made, which is a kind of double wooden compass, the legs of which are respectively curved to the shape of the inner and outer sides of the bell, a space of the exact form and thickness of the bell being left betwixt them. The compass is pivoted on a stake driven into the bottom of the casting-pit. A stuffing of brickwork is built round the stake, leaving room for a fire to be lighted inside it. The outside of this stuffing is then padded with fine soft clay, well mixed and bound together with calves' hair, and the inner leg of the compass run round it, bringing it to the exact shape of the inside of the bell. Upon this *core*, well smeared with grease, is fashioned the false clay bell, the outside of which is defined by the outer leg of the compass. Inscriptions are now moulded in wax on the outside of the clay-bell; these are carefully smeared with grease, then lightly covered with the finest clay, and then with coarser clay, until a solid *mantle* is thickened over the outside of the clay bell. A fire is now lighted, and the whole baked hard; the grease and wax inscriptions steam out through holes at the top, leaving the sham clay bell baked hard and tolerably loose, between the *core* and the *cope* or *mantle*. The *cope* is then lifted, the clay bell broken up, the *cope* set down again, enclosing now between itself and the *core* the exact shape of the bell. The metal is then boiled, and run molten into the mould. A large bell will take several weeks to cool. When extricated it ought to be scarcely touched, and should hardly require tuning. This is called its maiden state, and it is one so sought after that many bells are left rough and out of tune in order to claim it.

A good bell, when struck, yields one note, so that any person with an ear for music can say what it is. This note is called the *consonant*, and when it is distinctly heard the bell is said to be "true." Any bell of moderate size (little bells cannot well be experimented upon) may be

tested in the following manner:—Tap the bell just on the curve of the top, and it will yield a note one octave above the consonant. Tap the bell about one quarter's distance from the top, and it should yield a note which is the *quint* or fifth of the octave. Tap it two quarters and a half lower, and it will yield a *terce* or third of the octave. Tap it strongly above the rim where the clapper strikes, and the quint, the *terce*, and the octave will now sound simultaneously, yielding the consonant or key-note of the bell.

If the *terce* is too sharp the bell's note (i.e., the consonant) wavers between a tone and a half-tone above it; if the *terce* is flat the note wavers between a tone and a half-tone below it; in either case the bell is said to be "false." A sharp *terce* can be flattened by filing away the inside of the bell just where the *terce* is struck; but if the bell when cast is found to have a flat *terce* there is no remedy. The consonant or key-note of a bell can be slightly sharpened by cutting away the inner rim of the bell, or flattened by filing it a little higher up inside, just above the rim. (See H. R. Haweis's *Music and Morals*, 5th edition, p. 429.)

The quality of a bell depends not only on the casting and the fineness and mixture of metals, but upon the due proportion of metal to the calibre of the bell. The larger the bell the lower the tone; but if we try to make a large E bell with metal only enough for a smaller F bell, the E bell will be puny and poor. It has been calculated that for a peal of bells to give the pure chord of the ground tone or key-note, third, fifth, and octave, the diameters are required to be as thirty, twenty-four, twenty, fifteen, and the weights as eighty, forty-one, twenty-four, and ten.

The history of bells is full of romantic interest. In civilized times they have been intimately associated, not only with all kinds of religious and social rights, but with almost every important historical event. Their influence upon architecture is not less remarkable, for to them indirectly we probably owe all the most famous towers in the world. Grose in his *Antiquities* observes, "Towers at first scarcely rose above the roof, being intended as lanterns for the admission of light, an addition to the height was in all likelihood suggested on the more common use of bells."

Bells early summoned soldiers to arms, as well as citizens to bath or senate, or Christians to church. They sounded the alarm in fire or tumult; and the rights of the burghers in their bells were jealously guarded. Thus the chief bell in the cathedral often belonged to the town, not to the cathedral chapter. The curfew, the Carolus, and St Mary's bell in the Antwerp tower all belong to the town; the rest are the property of the chapter. He who commanded the bell commanded the town; for by that sound, at a moment's notice, he could rally and concentrate his adherents. Hence a conqueror commonly acknowledged the political importance of bells by melting them down; and the cannon of the conquered was in turn melted up to supply the garrison with bells to be used in the suppression of revolts. Many a bloody chapter in history has been rung in and out by bells.

On the third day of Easter 1282, at the ringing of the Sicilian vespers, 8000 French were massacred in cold blood by John of Procida, who had thus planned to free Sicily from Charles of Anjou. On the 24th of August, St Bartholomew's day, 1571, bells ushered in the massacre of the Huguenots in France, to the number, it is said, of 100,000. Bells have rung alike over slaughtered and ransomed cities; and far and wide throughout Europe in the hour of victory or irreparable loss. At the news of Nelson's triumph and death at Trafalgar, the bells of Chester rang a merry peal alternated with one deep toll, and similar

striking incidents could be indefinitely multiplied. It was, however, in the low countries of Belgium and Holland, distracted with incessant civil wars, that, for purely political reasons, bells acquired unique importance.

But their religious and civil uses may be further noticed. The Ave Mary bell tolled at 6 and 12 to remind men of prayer to the Virgin; the vesper bell for evening prayer; the compline was for the last service of the day. The sanctus, often a handbell, rung at the sacrifice of the mass; the passing bell, at death. The curfew (*couvre feu*), introduced by the Conqueror into England, rang at 8 o'clock to extinguish all lights. In many parts of the country and in university towns at 8 and 6 o'clock bells are still rung. At Antwerp cathedral we find the *Cloche de Triomphe*, by Dumery; sixteen bells at Sottoghem and several at Ghent and elsewhere bear the same maker's name. The Horrida, or ancient tocin at Antwerp, said to date from 1316, is long-shaped and is now unused. The curfew in the same tower rings at 5, 12, and 8. The Santa Maria (4½ tons) first rang when Carl the Bold entered Antwerp 1467. St Antoine is another celebrated bell, and the favourite Carolus, given by Charles V. (7¼ tons), is made of copper, silver, and gold, and valued at £20,000. At Straaburg we have the Holy Ghost bell, with motto, "O Rex glorie Christus veni cum pace," and date 1375, 3 nonas Augusti (8 tons), only rung when two fires are seen in the town at once. The recall or storm bell warns travellers in the plain of the storm coming from the Vosges Mountains. The Thor or gate bell, for shutting and opening gates of the city, has been cast three times (1618, 1641, and 1651); it bears the following inscription:—

"Dieses Thor Hooke das erst mal schalt  
Als man 1618 sahlt  
Dass Mgte Jahr regnet man  
Nach doctor Luther Jubal jahr  
Das Bße hinaus das Gut hinein  
Zu kerten soll igr arbeit seyn."

The Mittags, or 12 o'clock bell, taken down in the French Revolution, bore the motto—

"Vox ego sum vitæ  
Voco vos—orate—venite."

From all this it will appear that these Continental bells acquired a strong personality from the feelings and uses with which they were associated; and, indeed, they were formally christened with more ceremony than we give to christening our ships, and were then supposed to have the power of driving away evil spirits, dispersing storms, &c.

Bell-founding attained perfection in Holland in the 16th and 17th centuries; and the names of Hemony, Dumery, and the Van den Gheyns stand out as the princes of the art. Their bells are still heard throughout the Low Countries, and are plentiful at Amsterdam, Bruges, Ghent, Louvain, Mechlin, and Antwerp. These bells are frequently adorned with bas reliefs of exquisite beauty, such as feathers, forest leaves, fruit, flowers, portraits, or dancing groups, and inscribed with Latin, sometimes bad; but strong, quaint, and often pathetic. We give the preference to Hemony's small bells, and to Van den Gheyns's large ones. The names of Deklerk, Claes Noorden and Johann Albert de Grave (1714), Claude and Joseph Plumere (1664), Bartholomew Goethale (1680), and Andrew Steiliert (1663) also occur in Belgium. The following illustrate the nature of inscriptions and mottoes common in Belgium:—"Non sunt loquales noque sermones audiantur voces eorum," F. Hemony, Amsterdamia, 1688; "Laudate Domini omnes-gentes, F. Hemony, 1674;" and so a Ghent bell—

"Mynem neem is Roelant  
Als ick clippe dan ist trundt  
A's ick luyde dan is storm in Vlaenderland."

A common inscription runs—

"Funera plango, Fulgura frango, Sabbata pango,  
Excite lentos, Dissipo ventos, Peco crescentes."

A few other inscriptions which occur on bells in France and England may be quoted. The bell in the cathedral at Rouen, already mentioned, which was melted down by the Revolutionists in 1793, bore the words—

"Je suis George d'Ambots  
Qui trente cinque mille poids  
Mais lui qui me peesera  
Trente six mille me trouvera."

Bells of the parish church at Winnington, Bedfordshire, had—

"Nomina campanis hæc indita sunt quoque nostra."  
1st bell.—"Hoc signum Petri pulsator nomine Christi."  
2d "Nomen Magdalene campana sonat melode."  
3d "Sit nomen Domini benedictum semper in omni."  
4th "Musa Raphaelis sonat auribus Immanuelis."  
5th "Sum Rosa pulata mundique Marie vocata."

By an old chartulary it appears that the bells of the Priory of Little Dunmow, in Essex, were in the year 1501 new cast and baptized—

"Prima in honore Sancti Michaelis Archangeli.  
Secunda in honore Sancti Johannis Evangelisti  
Tertia in honore S. Johannis Baptistæ.  
Quarta in honore Assumptionis beate Mariæ.  
Quinta in honore sanctos Trinitatis et omnium sanctorum."

In the little sanctum at Westminster, Edward III. built a clocher, and placed in it bells for St Stephen's chapel, round the largest of which was cast—

"King Edward made mee thirty thousand weight and three  
Take me down and wey mee,  
And more you shall fynd mee."

Some of the music played on the carillon clavessin is still extant. We may specially mention the *serococo* *fugues* discovered by the Chevalier van Elweyck, in the archives at Louvain, the work of the celebrated organist and carillonneur Matthias van den Gheyn (published by Schott and Co., Brussels and London). This music is as fine in its way as Bach or Handel.

Quite lately several carillons have been put up in England; and one (1875) is in contemplation for St Paul's cathedral. The new carillon machinery by Messrs Gillett and Bland of Croydon, now employed almost everywhere in connection with clocks and carillons, is incomparably superior to anything of the kind on the Continent. By its aid the hammer, which falls on the outside of the bell, is raised mechanically instead of by the action of the fist or finger on the key; and all that the stroke on the key does is to let it slide off like a hair-trigger, and drop on the bell. Thus the touch of the modern carillon clavessin bids fair to rival that of the organ. The same firm has also invented a bell piano. The chief carillons in England at present are at Boston church, Lincolnshire, Worcester cathedral, Bradford town-hall, Rochdale town-hall, and Shoreditch. Several good peals of bells in London are immortalized in the common nursery rhyme—

"Gay go up and Gay go down,  
To ring the bells of London town."

Bell-ringing by rope is still a popular art in England. The first regular peal of bells in this country was sent in 1456 by Pope Calixtus III. to King's College, Cambridge, and was for 300 years the largest peal in England. At the beginning of the 16th century sets of eight bells were hung in a few large churches. In 1668 a famous work on bells, *Tintinnologia*, by T. W. [White], appeared, introducing a sort of bell-notation by printing the bells 1, 2, 3, 4, &c., on slips of paper in different orders according to the changes rung. Of these changes there is a great variety, spoken of technically as hunting, dodging, mapping, place-making, plain-bob, bob-triple, bob-major, bob-major reversed, double bob-major, grandsire-bob-cantor, &c.

The following numbers show how three bells can ring six changes:—1, 2, 3; 1, 3, 2; 2, 1, 3; 2, 3, 1; 3, 1, 2; 3, 2, 1. Four bells ring four times as many as three, i.e., twenty-four; five bells ring five times as many as four, or 120. And it may thus be shown that it would take ninety-one years to ring all the changes upon twelve bells at two strokes a second; whilst twenty-four bells would occupy more than 117 billions of years!

Bell-ringing is conducted as follows:—Ropes hang through holes in the bell-chamber, and are usually fastened to a wheel for leverage, round which the rope passes. There is a great knack in handling the rope. The first half-pull "drops" the bell, the second "sets" it; it next swings up to the slur-bar, then it swings down and up to the other side, the clapper striking as it ascends. Eight bells make the most perfect peal, tuned in the diatonic scale.

Bells are struck in three ways,—(1) with a hammer on the outside, let off either by a tambour or revolving drum; similar in appearance to the prickly cylinder of a musical box, which drum can be fitted with tunes or chimes by musical nuts or spikes, and altered at will; (2) the bell can also be struck by hand, as in the common stand of small bells to be seen occasionally in the London streets, the player having a hammer in each hand; or (3) the clapper may strike the bell internally, either being pulled by a rope, the bell being stationary, or by the bell swinging to and fro. If the hammer or clapper be too light the tone of the bell is not properly drawn; if too heavy it will pulverize or crack the bell in time.

Great reforms are needed in the hanging of bells, a subject to which the Americans have given much attention. What Messrs Gillett and Bland are in England with reference to carillon machinery, the Meneslys of New York are to the ordinary mechanism and hanging of bells. There is hardly a cathedral tower in England where the hanging of one or more bells, or the oscillation of the tower, is not justly complained of. When a bell is hard to ring it is usually on account of its hanging. The leverage is wrongly applied; the wood-work is crowded against the masonry, and many of the finest towers have thus become unsafe.

There are a few bells of world-wide renown, and several others more or less celebrated. The great bell at Moscow, *Tsar Kolokol*, which, according to the inscription, was cast in 1733, was in the earth 103 years, and was raised by the Emperor Nicholas in 1836. The present bell seems never to have been actually hung or rung, having cracked in the furnace. Photographs of it are now common, as it stands on a raised platform in the middle of a square. It is used as a chapel. It weighs about 440,000 lb; height, 19 feet 3 inches; circumference, 60 feet 9 inches; thickness, 2 feet; weight of broken piece, 11 tons. The second Moscow bell, the largest in the world in actual use, weighs 128 tons. The great bell at Peking weighs 53 tons; Nanking, 22 tons; Olmutz, 17 tons; Vienna (1711), 17 tons; Notre Dame (1680), 17 tons; Erfurt, one of the finest bell metal, 13 tons; Great Peter, York Minster, which cost £2000 in 1845, 10 tons; St Paul's, 5 tons; Great Tom at Oxford, 7 tons; Great Tom at Lincoln, 5 tons. Big Ben of the Westminster clock tower (cracked) weighs between 13 and 14 tons; it was cast by George Mears under the direction of Edward Beckett Denison in 1858. Its four quarters were cast by Warner in 1856. The Kaiserglocke of Cologne cathedral, lately recast (1875), weighs 25 tons.

On the varied uses past and present of small bells a volume might be written. Octaves of little bells have been introduced into organs and utilized in the orchestra. Handringers are still common throughout the country—one man with a bell fitted with a clapper, in each hand,

ringing but two notes of the tune in his turn. Upright stands of bells without clappers, struck with hands, may often be seen in the streets. Bells for horses, dogs, cows, sheep, &c., have already been alluded to. In Italy and elsewhere they are often made of baked earth; these have a very sweet sound, and cost about a penny. For sledges and harness they are of metal, and worn usually in bunches. A bunch of twelve costs about two francs. On the Italian lakes and elsewhere a bell fixed to a floating cork marks the spot where lines or nets are laid for fish. Hunting-hawks were formerly supplied with small bells to facilitate recovery.

Whilst some uses of bells have gone out, new ones have come in. A few instances will give the reader some idea of the indefinite number of services to which they have been applied. The expression to curse with book, bell, and candle, alludes to an old form of exorcism, in which the bell was used to scare the evil spirit—a function also attributed to larger bells. Bearing the bell alludes to the prize of a silver bell usually given at horse-races to the winner; hence comes what is, after all, only the bell reversed and used as a drinking vessel—the prize cup. The diving-bell no more comes within the scope of the present article than the dome of a mosque. Certain uses of small bells are fast disappearing. The dustman's bell is now seldom heard. The town-crier, with his "Oh, yes" (*oyez, hear ye*), has been banished to the provinces. The 5 o'clock postman, with his hand-bell to collect letters, went out when the present postal system came in. On the other hand the muffin-bell, the railway-bell, the dock-bell, the half-hour bells at sea, and the stage-bell survive; whilst new applications, unknown to our forefathers, have been introduced. Few people are aware that house-bells worked with wires are scarcely 100 years old. Long before them, no doubt, handbells had to a great extent superseded the use of the horn, whistle, rattle, clapping of hands, and hammering on the door with a stick, and fire-bells were in frequent use. The old bell-pulls, which still linger in country inns and mansions, have been replaced by spring handles in the walls, and these are disappearing from hotels and clubs in favour of electric bells, now so common in railway stations in connection with the telegraph. A current of electricity sets a small hammer in motion, and, in the dark, the stream of sparks between the hammer and bell is clearly visible. In a word, then, it is plain that the whole of civilized life is set to bell music in one shape or another; and although the more important uses of bells have been enumerated, time would fail to mention all their lowly but not less useful functions,—such as the familiar dinner-bell, yard-bell, school-bell, factory-bell, jail-bell, small portable cupola spring-bell (pressed with the hand), spring signal door-bell (used in shops), safety-bell on swinging coil (fastened to shutters or doors); and, not to forget the nursery, the coral and bells, bell-rattles—which call to mind, and are probably relics of, the old fool's cap and bells and fool's wand with its crown of jingling baubles, or it may be that the fool's baubles are copies of the child's playthings.

The Rev. H. T. Ellacombe, author of various works on bells, gives in his *Chiming* a complete catalogue of bell literature. (H. T. E.)

BELL, DR ANDREW, a clergyman of the Church of England well known for his philanthropic efforts in the cause of education, and more particularly for his success in extending the monitorial system of instruction in schools, was born at St Andrews in 1753. He graduated at the university of that town, and afterwards spent some years in America. In 1789 he was chaplain at Fort St George, and minister of St Mary's church, Madras. While in this position he occupied himself with instructing the orphan children of the military asylum, and having been obliged

from scarcity of teachers to introduce the system of mutual tuition by the pupils, found the scheme answer so well that he became convinced of its universal applicability. In 1797, after his return to London, he published a small pamphlet explaining his views. No public attention was drawn towards the plan till the following year, when Mr Joseph Lancaster, a dissenter, opened a school in Southwark, conducting it in strict accordance with Bell's principles. The success of the method, and the strong support given to Lancaster by the whole body of dissenters, gave immense impetus to the movement. Similar schools were established in great numbers; and the members of the Church of England, becoming alarmed at the patronage of these schools resting entirely in the hands of dissenters, resolved to set up similar institutions in which church principles should be inculcated. In 1807 Dr Bell was called upon to organize a system of schools in accordance with these views. For his valuable services he was in some degree recompensed by his perferment to a prebend of Westminster, and to the mastership of Sherborn Hospital, Durham. He died in 1832 at Cheltenham, and was buried in Westminster Abbey. His great fortune was bequeathed almost entirely for educational purposes. Of the £120,000 given in trust to the provost of St Andrews, two city ministers, and the professor of Greek in the university, half was devoted to the founding of the important school, called the Madras College, at St Andrews; £10,000 was left to each of the large cities, Edinburgh, Glasgow, Leith, Inverness, and Aberdeen, for school purposes; and £10,000 was also given to the Royal Naval School. (See Southey's *Life of Dr Bell*.)

BELL, SIR CHARLES, K.H., the youngest son of the Rev. William Bell, a clergyman of the Episcopal Church of Scotland, was born at Edinburgh, November 1774. His mother Margaret Morice, the elder daughter of an Episcopal clergyman, was remarkable for her piety and general accomplishments, and she exercised a powerful influence over her gifted sons. The father, William Bell, after a life of contending with difficulties, died on 20th of September 1779, aged seventy-five, leaving his wife and six children very slenderly provided for. Of these six children, three became distinguished men, namely, John Bell, the anatomist and surgeon; George Joseph Bell, professor of the law of Scotland in the University of Edinburgh; and Charles Bell, the subject of this notice. After having studied two years at the High School and two years more at the University of Edinburgh, Charles embraced the profession of medicine and devoted himself chiefly to the study of anatomy, under the direction of his brother John, who was twelve years older, and who had already earned a reputation as an anatomist and surgeon. Regarding his early education, he wrote, in 1839, on a copy of Pettigrew's *Medical Portrait Gallery*, opposite a remark that he had been educated at the High School,—“Nonsense! I received no education but from my mother, neither reading, writing, ciphering, nor anything else.” At school and college he does not appear to have distinguished himself, except by his facility in drawing, a hereditary gift acquired from his mother. It was not until he entered on the study of anatomy that he gave evidence of possessing those talents which soon made him a worthy rival of his brother John.

His first work, entitled *A System of Dissections, explaining the Anatomy of the Human Body, the manner of displaying the Parts, and their Varieties in Disease*, was published in Edinburgh in 1798, while the author was still a pupil. The “Introduction” to this work shows much originality of thought, and an aptitude for devising new methods of preparing animal structures for dissection and demonstration. The volume is illustrated by numerous engravings from original drawings, and the text is clear and precise in

language. For many years this work was considered to be a valuable guide to the student of practical anatomy.

On the 1st of August 1799 he became a fellow of the Royal College of Surgeons of Edinburgh. At that time the fellows of the college were in rotation surgeons to the Royal Infirmary of Edinburgh. In this position Bell soon gave evidence of great ability. He dissected, drew, described, mounted preparations of anatomical, physiological, or pathological value, improved on the modes of operating in surgery known at that time, and invented a method of making models of morbid parts, of which specimens may still be seen in the museum of the college.

In 1803 he published a series of engravings of original drawings, showing the anatomy of the brain and nervous system. These drawings are remarkable for artistic skill and finish. They were taken from dissections made by Bell for the lectures or demonstrations he gave on the nervous system as part of the course of anatomical instruction of his brother. In 1804 he wrote volume iii. of *The Anatomy of the Human Body*, by John and Charles Bell. This volume contains the anatomy of the nervous system, and of the organs of special sense.

In 1804 a new arrangement was made regarding the attendance of surgeons at the Edinburgh Infirmary; and Bell, probably as being junior in the profession, was excluded from the hospital. He proposed to the managers to pay £100 a year, and to transfer to them, for the use of the students, the museum he had collected, on condition that he should be “allowed to stand by the bodies when dissected in the theatre of the infirmary, and to make notes and drawings of the diseased appearances.” This enthusiastic proposal was rejected, and the consequence was that Bell went to London in November 1804.

From that date, for nearly forty years, he kept up a regular correspondence with his brother George, much of which has recently been published (*Letters of Sir Charles Bell, &c.*, 1870). The earlier letters of this correspondence show how rapidly he rose to distinction in a field where success was difficult, as it was already occupied by such men as Abernethy, Sir Astley Cooper, and Cline. He quickly made acquaintance with most of the scientific men of the day, and apparently won friends in the highest social, professional, and artistic circles. After having lodged in Fludyer Street for some months, he settled in Leicester Street, Leicester Square, and immediately commenced a course of lectures on anatomy and surgery. Here he also located his museum, which was sent to him from Edinburgh; and his letters indicate that this was the subject of much interest to scientific and professional men. He lectured to painters, directed private dissections, gave demonstrations to surgeons, and gradually acquired a surgical practice.

Before leaving Edinburgh in 1804, he had written his work on the *Anatomy of Expression*. It was published in London soon after his arrival, and at once attracted attention. His practical knowledge of anatomy and his skill as an artist qualified him in an exceptional manner for such a work. The object of this treatise was to describe the arrangements by which the influence of the mind was propagated to the muscular frame, and to give a rational explanation of the muscular movements which usually accompany the various emotions and passions. One special feature of the author's system was the importance attributed to the respiratory arrangements as a source of expression. He also showed how the physician and surgeon might derive information regarding the nature and extent of important diseases by observing the expression of bodily suffering. This work, apart from its value to artists and psychologists, is of interest historically, as there is no doubt the investigations of the author into the nervous supply of the muscles of expression induced him to prosecute inquiries which led to



his great discoveries in the physiology of the nervous system.

In 1807 Bell first published his idea of a new anatomy of the brain, in which he announced the discovery of the different functions of the nerves corresponding with their relations to different parts of the brain. It is now difficult to imagine the confusion which prevailed in the minds of anatomists and physiologists regarding the functions of the various nerves prior to this discovery. The nerves had been noticed by anatomists from the earliest times, and they were divided into cranial and spinal nerves, according as they originated from the brain or spinal cord. Some were supposed to carry from the brain the mandates of the will, while others communicated to the sensorium impressions made on their extremities, which resulted in consciousness. It was supposed, however, that the same nerve, even at the same time, might in some mysterious way transmit either motor or sensory impressions in opposite directions. When a nerve was cut, the parts beyond the incision were found to be destitute of sensibility, and to be beyond the influence of the will. It was consequently correctly inferred to be the cord through which volition acted on the muscles, and through which sensory impressions were transmitted to the sensorium. The idea of two sets of filaments functionally different in the same nerve was not then entertained. Boerhaave asserted that there were two kinds of spinal nerves, the one serving for motion and the other for the use of the senses. Haller states, "I know not a nerve which has sensation without also producing motion." The first Monro held a similar opinion, and he believed all those spinal nerves which passed through a ganglion to be motor nerves.

To Sir Charles Bell we owe the discovery that in the nervous trunks there are special sensory filaments, the office of which is to transmit impressions from the periphery of the body to the sensorium, and special motor filaments which convey motor impressions from the brain or other nerve centre to the muscles. He also showed that some nerves consist entirely of sensory filaments and are therefore sensory nerves, that others are composed of motor filaments and are therefore motor nerves, whilst a third variety contain both kinds of filaments and are therefore to be regarded as sensory-motor. Furthermore, he indicated that the brain and spinal cord may be divided into separate parts, each part having a special function—one part ministering to motion, the other to sensation, and that the origin of the nerves from one or other or both of those sources endows them with the peculiar property of the division whence they spring. He also demonstrated that no motor nerve ever passes through a ganglion. Lastly, he showed both from theoretical considerations and from the result of actual experiment on the living animal, that the anterior roots of the spinal nerves are motor, while the posterior are sensory. These discoveries as a whole must be regarded as the greatest in physiology since that of the circulation of the blood by the illustrious Harvey. It not only was a distinct and definite advance in scientific knowledge, but from it flowed many practical results of much importance in the diagnosis and treatment of disease. It is not surprising that Bell should have announced it to his friends with exultation. On 26th November 1807 we find him writing as follows to his brother George:—"I have done a more interesting *nova anatomia cerebri humani* than it is possible to conceive. I lectured it yesterday. I prosecuted it last night till one o'clock; and I am sure it will be well received." On the 31st of the same month he writes—"I really think this new anatomy of the brain will strike more than the discovery of the lymphatics being absorbents."

In 1807 he produced a *System of Comparative Surgery*

founded on the basis of anatomy. This work indicates the author's idea of the science of surgery. He regarded it almost wholly from an anatomical and operative point of view, and there is little or no mention of the use of medicinal substances. It placed him, however, in the highest rank of English writers on surgery.

In 1809 he relinquished his professional work in London, and rendered meritorious services to the wounded from Coruña, who were brought to the Haslar Hospital at Portsmouth. In 1810 he published a series of *Letters concerning the Diseases of the Urethra*, in which he treated of stricture from an anatomical and pathological point of view.

In 1812 he was appointed surgeon to the Middlesex Hospital, and a few years afterwards professor of anatomy, physiology, and surgery to the College of Surgeons of London. He was also for many years teacher of anatomy in the school of Great Windmill Street, no longer in existence. He acted as surgeon to the hospital for twenty-four years, and delivered many courses of lectures on surgery in that institution. In 1815 he did good public service by devoting all his skill and time to the wounded after the battle of Waterloo. On the formation of University College, Gower Street, he was asked to place himself at the head of the medical department. This appointment he held for only a short time, when he resigned in consequence, it is said, of dissensions in the senate.

In 1816, 1817, 1818, he published a series of *Quarterly Reports of Cases in Surgery, treated in the Middlesex Hospital, in the Cancer Establishment, and in Private Practice, embracing an Account of the Anatomical and Pathological Researches in the School of Windmill Street*. In 1821 he issued a volume of coloured plates with descriptive letterpress, entitled *Illustrations of the Great Operations of Surgery, Trepan, Hernia, Amputation, and Lithotomy*. In 1824 appeared *An Exposition of the Natural System of Nerves of the Human Body; being a Republication of the Papers delivered to the Royal Society on the subject of the Nerves*. In the same year he wrote *Observations on Injuries of the Spine and of the Thigh Bone*. In 1832 he wrote a paper for the Royal Society of London on the "Organs of the Human Voice," in which he gave many illustrations of the physiological action of these parts.

Of an eminently pious and reflective mind, he was often in the habit of pointing out in his lectures what he regarded as evidences of creative design to be found in the anatomy of the bodies of animals. These he embodied in a treatise on *Animal Mechanics*, written for the Society for the Diffusion of Useful Knowledge. The executors of the earl of Bridgewater selected him as a fit person to maintain the argument which it was the purpose of that nobleman's bequest to have published. Sir Charles wrote in 1833—*The Hand: its Mechanism and Vital Endowments as evincing Design*. Along with Lord Brougham he annotated and illustrated an edition of Paley's *Natural Theology*, published in 1836, in which he followed out his favourite line of thought.

The Royal Society of London awarded to him in 1829 the first annual medal of that year given by George IV. for discoveries in science; and when William IV. ascended the throne, Charles Bell received the honour of knighthood along with a few other men distinguished in science and literature.

The chair of surgery in the University of Edinburgh was offered to him in 1836. When the offer was made he was regarded as one of the foremost scientific men in London, and he had a large surgical practice. But his opinion was "London is a place to live in, but not to die in;" and he accepted the appointment. In Edinburgh he did not earn great local professional success; and, it must be confessed,

he was not appreciated as he deserved. But honours came thick upon him. On the Continent he was spoken of as greater than Harvey. It is narrated that one day Roux, a celebrated French physiologist, dismissed his class without a lecture, saying "C'est assez, Messieurs, vous avez vu Charles Bell." He held the Edinburgh chair from 1836 to 1842. During his professorship, in 1838, he published the *Institutes of Surgery, arranged in the order of the Lectures delivered in the University of Edinburgh*; and in 1841 he wrote a volume of *Practical Essays*, two of which "On Squinting," and "On the Action of Purgatives," are of great value.

Sir Charles Bell died at Hallow Park near Worcester on Thursday, 28th April 1842, in his sixty-eighth year; and he lies under the yew tree in the peaceful churchyard of Hallow. His epitaph, written by his life-long friend Lord Jeffrey, summarizes his character as follows:—"Sacred to the memory of Sir Charles Bell, who, after unfolding, with unrivalled sagacity, patience, and success, the wonderful structure of our mortal bodies, esteemed lightly of his greatest discoveries, except only as they tended to impress himself and others with a deeper sense of the infinite wisdom and ineffable goodness of the Almighty Creator: He was born at Edinburgh 1774; died, while on a visit of friendship, at Hallow park, in this parish, 1842; and lies buried in the adjoining churchyard." (J. C. M.)

BELL, GEORGE JOSEPH, brother of the preceding, was born at Edinburgh on the 20th of March 1770. At the age of eight he entered the High School, but he received no university education further than attending Tytler's lectures on civil history, Stewart's course of moral philosophy; and Hume's lectures on the law of Scotland. He became a member of the Faculty of Advocates in 1791, and was one of the earliest and most attached friends of Francis Jeffrey. In 1804 he published a *Treatise on the Law of Bankruptcy in Scotland*, in 2 vols. 8vo, which was gradually enlarged in subsequent editions, till at length a fifth edition was published in 1826, in 2 vols. 4to, under the title of *Commentaries on the Law of Scotland and on the Principles of Mercantile Jurisprudence*—an institutional work of the very highest excellence, which has guided the judicial deliberations of his own country till the present time, and has had its value acknowledged by such eminent jurists as Story and Kent. In 1821 he was unanimously elected professor of the law of Scotland in the University of Edinburgh; and in 1831 he was appointed to one of the principal clerkships in the Supreme Court. He was in 1833 placed at the head of a commission to inquire into the expediency of making various improvements in the Scottish bankruptcy law; and in consequence of the reports of the commissioners, chiefly drawn up by himself, many beneficial alterations have been made in this department of the law. He died on the 23d September 1843. A seventh edition of the *Commentaries*, edited by J. Maclaren, advocate, appeared in 1870. Bell's smaller treatise, *Principles of the Law of Scotland* (6th edit. 1872), has long been a standard text-book for law students. The *Illustrations of the Principles* is also a work of high value.

BELL, HENRY, a mechanical engineer, well known for his successful application of steam-power to the propulsion of ships, was born at Torphichen, in Linlithgowshire, in 1767. Having received the ordinary education of a parish school, he was apprenticed to his uncle, a millwright, and, after qualifying himself as a ship-modeller at Ro'ness, went to London, where he found employment under Rennie, the celebrated engineer. Returning to Scotland in 1790, he first settled as a carpenter at Glasgow and afterwards removed to Huiensburgh, on the Firth of Clyde, where his wife superintended a large inn, together with the public baths, while he pursued his mechanical projects, and also

found occasional employment as an engineer. It was not until January 1812 that he gave a practical solution of the difficulties which had beset all previous experimenters, by producing a steamboat (which he named the "Comet,") of about 25 tons, propelled by an engine of three-horse power, at a speed of seven miles an hour. Although the honor of priority, by about four years, is admitted to belong to Robert Fulton, an American engineer, there appears to be no doubt that Fulton had received very material assistance in the construction of his vessel from Bell and others in this country. A handsome sum was raised for Bell by subscription among the citizens of Glasgow; and he also received from the trustees of the River Clyde a pension of £100 a year. He died at Helensburgh, 14th November 1830, and a monument was erected to his memory at Dungleass, near Bowling, on the banks of the Clyde.

BELL, HENRY GLASGOW, was born at Glasgow in 1805, and received his education at the High School of that city. He afterwards studied at Edinburgh and became intimate with Moir, Hogg, Wilson, and others of the brilliant staff of *Blackwood's Magazine*, to which he was drawn by his political sympathies. In 1828 he became editor of the *Edinburgh Literary Journal*, which proved unsuccessful. He passed to the bar in 1832. In 1836 he competed unsuccessfully against Sir William Hamilton for the chair of logic and metaphysics in Edinburgh University, and three years afterwards was appointed sheriff-substitute of Lanarkshire, an office which he held until 1867, when he succeeded Sir Archibald Alison in the post of sheriff-principal of the county. During his early life he had been a versatile author of poems and prose sketches, but his literary activity was checked after he applied himself seriously to law. In 1831 he published *Summer and Winter Hours*, a volume of poems, of which the best known is that on Mary Queen of Scots. He further defended the cause of the unfortunate queen in a prose *Life*. A preface which he wrote to the works of Shakespeare contains some acute and original criticism. His *Romances and other Poems* (1866) display deeper thought and less fervour than his former works, but are mainly interesting as evidence of latent poetic genius, the development of which was prevented by attention to other pursuits. Bell's literary tastes did not affect his industry in his profession, and, on the other hand, his legal labours never dulled his early affection for poetry and painting. He deserves to be held in kindly remembrance for his readiness to assist youthful literary aspirants. During many years he took an active interest in social questions, especially in promoting educational and sanitary reforms. He died in January 1874.

BELL, JOHN, of Antermony, a Scottish traveller in the first half of the last century, was born in 1691, and educated for the medical profession, in which he took the degree of M.D. In 1714 he set out for St Petersburg, where, through the introduction of a countryman, he was nominated medical attendant to Valenski, recently appointed to the Persian embassy, with whom he travelled from 1715 to 1718. The next four years he spent in an embassy to China, passing through Siberia and the great Tatar deserts. He had scarcely rested from this last journey when he was summoned to attend Peter the Great in his perilous expedition to Derbend and the Caspian Gates. The narrative of this journey he has enriched with interesting particulars of the public and private life of that remarkable prince. In 1738 he was sent by the Russian Government on a mission to Constantinople, to which, accompanied by a single attendant who spoke Turkish, he proceeded, in the midst of winter and all the horrors of a barbarous warfare, returning in May to St Petersburg. It appears that after this he was for several years established as a merchant at Constantinople, where he married

in 1746. In the following year he retired to his estate of Antermony in Scotland, where he spent the remainder of his life. He died in 1780. His travels, published at Glasgow, in 2 vols. 4to, 1763, were speedily translated into French, and widely circulated in Europe.

BELL, JOHN, anatomist and surgeon, was born at Edinburgh, 12th May 1763. He had the merit of being the first in Scotland who applied with success the science of anatomy to practical surgery. While still a young man he established, in the face of much opposition, an anatomical theatre in Surgeon Square, where he attracted large audiences by his admirable lectures on anatomy, physiology, and surgery, in which he was assisted by his younger brother Charles. After his exclusion from the infirmary (to which reference has been made in the notice of Sir Charles Bell), he ceased to lecture, and devoted his time to study and practice. He died at Rome in 1820, while on a tour in Italy for the benefit of his health. To great skill in his profession he united high and varied mental abilities and extensive learning.

His principal works are — *Anatomy of the Human Body*, 3 vols. 8vo, 1793-1801; *Discourses on the Nature and Cure of Wounds*, 2 vols. 8vo, 1793-95; *Principles of Surgery*, 3 vols. 8vo, 1801; and several volumes of Engravings illustrative of Human Anatomy. His *Observations on Italy* were published by his widow in 1825.

BELL, ROBERT, editor of the *Annotated Edition of the British Poets*, was an Irishman by birth and education, but a Londoner by a long residence of nearly forty years. He was born at Cork in 1800, and was educated at Trinity College, Dublin. With the tasks of a subordinate in a Government office at Dublin he combined literary pursuits, editing a political journal and contributing to periodicals. In 1828 he settled in London, and literature was thenceforward the business of his life. As journalist he edited the *Atlas* for several years; and afterwards the *Monthly Chronicle*, *Mirror*, and *Home News*. Of his early undertakings the more important were the volumes which he compiled for Lardner's *Cabinet Cyclopaedia*, including the *Lives of British Admirals*, in continuation of Southey's work; *Lives of British Poets*; a *History of Russia*; and the continuation of Sir James Mackintosh's *History of England*. He made himself favourably known as a novelist by *The Ladder of Gold and Hearts and Altars*. Among his other works are a *Life of Canning*, *Wayside Pictures in France, Belgium, and Germany*, three five-act comedies, and a volume entitled *Memorials of the Civil War*, based on the *Fairfax Correspondence*. He earned a higher place and a more enduring reputation by his *Annotated Edition of the British Poets*, of which the first volume appeared in 1854. The series was carried through twenty-nine volumes. The works of each poet are prefaced by a carefully-prepared memoir, and accompanied by explanatory and illustrative notes, of a really helpful and often indispensable kind. In his earlier years Bell had taken a leading part in founding the Dublin Historical Society. In the course of his London life he became an active director of the Royal Literary Fund. He was also chosen F.S.A. In private life he was highly esteemed and warmly loved for his open-heartedness, his genial temper, and his generous readiness to give aid to fellow-workers who might be in need. He died in London, at the age of sixty-seven, April 12, 1867.

BELLA, STEFANO DE LA, engraver, was born at Florence in 1610. He was apprenticed to a goldsmith; but some prints of Callot having fallen into his hands, he began to turn his attention entirely towards engraving, and studied the art under Cante Gallina, who had also been the instructor of Callot. By the liberality of Lorenzo de' Medici he was enabled to spend three years in study at Rome. In 1642 he went to Paris, where Cardinal Richelieu engaged him to go to Arras and make drawings of the siege and

taking of that town by the royal army. After residing a considerable time at Paris he returned to Florence, where he obtained a pension from the grand duke, whose son, Cosmo, he instructed in drawing. He died in 1664. His productions were very numerous, amounting to over 1400 separate pieces.

BELLADONNA, DWALE, or DEADLY NIGHTSHADE (*Atropa Belladonna*), a tall bushy herb of the natural order *Solanaceae*, growing to a height of 4 or 5 feet, having leaves of a dull green colour, with a black shining berry fruit about the size of a cherry, and a large tapering root. The plant is a native of Central and South Europe, extending into Asia, and it is also found in waste places and hedge-rows of Britain, though it is a doubtful native. The entire plant is highly poisonous, and accidents not unfrequently occur through children and unwary persons eating the attractive-looking fruit. Its leaves and roots are largely used in medicine, on which account the plant is cultivated, chiefly in South Germany, Switzerland, and France. Both roots and leaves contain the poisonous alkaloid atropia, but in practice the roots only are employed for its extraction. The proportions in which atropia is present in the roots range between 0.6 and 0.25, the roots of young plants being always richest in the alkaloid. The percentage found in leaves is much more uniform, being about 0.47, and extracts and tinctures of the leaves are therefore of much more constant strength than if prepared from roots. Preparations of belladonna and atropia are used in medicine as anodynes in local nervous pains,—atropia being frequently hypodermically injected but rarely taken internally. They are also of great value in ophthalmic practice on account of their peculiar property of producing dilatation of the pupil, either when painted around or dropped into the eye. Belladonna is also used as an antispasmodic in whooping-cough and spasmodic coughs generally, and for various other medicinal purposes. A remarkable antagonism between the physiological action of atropia and the alkaloid of the calabar bean has been experimentally worked out by Dr Thomas R. Fraser (*Trans. Roy. Soc. Ed.*, 1870-1). To a more limited extent also an antagonism between atropia and morphia and other alkaloids has been established; and the researches on these substances, and on the mutual action of alkaloids generally, have been continued in experiments conducted by Dr J. G. M'Kendrick, reported to the British Medical Association in 1874.

BELLAI, or BELLAY, GUILLAUME DU, lord of Langey, a French general, who signalized himself in the service of Francis I., was born at Glatigny in 1491. He was considered the ablest captain of the time, and his great abilities as a negotiator occasioned the remark of the Emperor Charles V., that "Langey's pen had fought more against him than all the lances in France." He was sent in 1537 as viceroy into Piedmont, where he took several towns from the imperialists. His address in penetrating into the most secret designs of the enemy was extraordinary, and he spared no expense for that end. He was extremely active in influencing some of the universities of France to give a judgment agreeable to the desires of Henry VIII., when that prince wished to divorce his queen in order to marry Anne Boleyn. Langey composed several works, the most remarkable of which was the history of his own times (*Mémoires*, 1753, 7 vols.) He died in 1543, and was buried in the church of Mans, where a noble monument was erected to his memory.

BELLAMY, JACOBUS, a Dutch poet, was born at Finshing in 1757. He was apprenticed when young to a baker, but his abilities were discovered by a clergyman named De Water, who exerted himself in the boy's behalf, and obtained sufficient assistance to send him, in 1782, to

the University of Utrecht. In 1785 appeared his *Vaderlandsche Gesangen*, which at once gained him the highest reputation as a poet. Three years previously a small volume of his, *Gesangen mijner Jougd*, published under the pseudonym *Zelandus*, had attracted considerable attention. His longest and, in the opinion of many, his best work is the poetic romance *Roope*, 1784. Bellamy was one of the first to create a new and original literature in Holland; his songs have had wide circulation and great popularity.

BELLARMINE (Ital. BELLARMINO), ROBERT FRANCIS ROMULUS, Cardinal, Catholic theologian and polemic, was born, October 4, 1542, at Montepulciano, in Tuscany. He was destined by his father for state service, but his inclinations were too strong to be restrained, and at the age of eighteen he entered the Society of Jesus. After studying in various colleges for some years, he was appointed by the order to lecture on theology at the famous university of Louvain. His seven years' residence in the Low Countries brought him into close relations with modes of thought differing essentially from his own, and so compelled him to define his theological principles more clearly and sharply than before. On his return to Italy he received from Gregory XIII. an appointment in the newly-founded *Collegium Romanum*, and began to deliver lectures on the principal points of difference between the Roman Catholic and other forms of faith. Out of these lectures grew his famous work, *Disputationes de Controversiis Christiana Fidei adversus hujus temporis Hæreticos* (3 vols., 1581, 1582, 1593), for long the finest polemical writing on the Catholic side, and still worthy of consideration. It was replied to at the time by Chemnitz, Gerhard, and Chamier, and continued for many years to furnish occasions of attack to Protestant theologians. So highly were Bellarmine's abilities rated, that he was selected to accompany, in the capacity of divine or theologian, the legation sent into France in 1590 by Sixtus V. In 1599 he was, much against his will, raised to the dignity of cardinal, and two years later was made archbishop of Capua. He resigned the archbishopric in 1605, being detained in Rome by the desire of the newly-elected Pope Paul V. About the same time he had a controversy with James I. of England, who, after the discovery of the Gunpowder Plot, had passed severe laws against Roman Catholics. In 1610 he published his work *De Potestate summi Pontificis in rebus Temporalibus*, directed against William Barclay, in which he asserted boldly and undisguisedly the doctrine of the Pope's temporal sovereignty. For some years before his death, which occurred at Rome, 17th September 1621, he held the bishopric of his native town. Bellarmine, whose life was a model of Christian asceticism, is one of the greatest theologians, particularly in the department of polemics, that the Romish Church has ever produced. His works, which are very numerous, are written in an easy perspicuous style. The most important are the *Disputatio de Controversiis*, the *De Potestate summi Pontificis*, *Institutiones Hebræica Lingua*, *De Scriptoribus Ecclesiasticis*, *De Actionibus Mentis in Deum*. A life of Bellarmine, founded on an autobiography, was written by Fulligato, 1624.

BELLAY, JOACHIM DU, an eminent French poet and member of the Pleiad, was born late in 1524, at Lyré, on the left bank of the Loire, not far from Angers. In the absence of documents we are thrown upon the autobiographical passages in his poems for information about the events of his life, and these, fortunately, are copious. From these, and especially from the beautiful Latin elegy addressed to his friend Jean Morel, we learn that, deprived early of both his parents, he was left to the mercy of an elder brother, who allowed him to be brought up without other education than what his own ardent spirit supplied.

Before he reached manhood this brother also died, and Joachim found himself at the head of the family, a vigorous, manly, but half-cultured youth. Suddenly he was stricken down by illness; and, confined for many months to his bed, he softened the long hours of suffering by fervent study; he now read the Latin and Greek poets for the first time, and felt a passionate desire to imitate them in French. In 1548, having to a great measure recovered his health, he happened to meet Ronsard in an inn in Poitiers, and a friendship instantly sprang up between them that ceased only with Du Bellay's death. He joined the six poets, who, under Dorat, were forming a society, the Pleiad, for the creation of a French school of Renaissance poetry; and his first contribution to it was a prose-volume, the famous *Defence et Illustration de la Langue françoise*, which remains one of the earliest and most perfect pieces of literary criticism in existence, and overweighs in positive value much of his actual poetry. This appeared in 1549, and was followed within a twelvemonth by two volumes in verse, the *Recueil de Poésie*, and the collection of love-sonnets called *L'Olive*. The latter celebrate, in the manner of Petrarch, the loveliness of a semi-mythical mistress, understood to be a Parisienne, and by name *Viola*, of which *Olive* is an anagram. The *Recueil* caused a quarrel with Ronsard, about which much speculation has been wasted, and which still remains obscure. It seems that Ronsard had invented a new form of the ode, which he allowed Du Bellay to see in manuscript. Ronsard's book was delayed in publication, and Du Bellay's odes, written after his metrical pattern, appeared first. Ronsard's natural and passing vexation has been exaggerated into a law-suit; but the friends were soon on the old affectionate footing. In *L'Olive* Du Bellay was the first French writer to use the sonnet with fluency. After he had translated two books of the *Æneid*, which appeared in 1552, the yearning he had always felt to visit Italy was appeased by his being sent to Rome in 1550 as secretary to his influential relative, Cardinal du Bellay, and he remained in that city four years and a half. At first, however, he was miserable enough. Everything around him was displeasing to him and jarred on his refined and sometimes sickly nerves. At last he fell violently in love with a lady, whose real name was Faustine, but whom he celebrates under the poetical title of *Columbe* and *Columbelle*. In his Latin poems this sincere and absorbing passion burns like a clear flame, more veiled though no less burning in his French *Regrets*. Before he won her she was shut up from his sight by her old and jealous husband. Frenzied with grief and desire, burning with fever, exhausted with watching and physical suffering,—for his health was still very delicate,—Du Bellay walked day and night to and fro before the house. At last, mysteriously enough, she is given to him; and the Latin poems end in rapturous delight. At this point, however, and possibly for this reason, he was hurried back to Paris, where he became canon of *Nôtre Dame* in June 1555. He returned by Venice, the Grisons, and Geneva, and was received by his friends in France with transport. He set himself to literary labour of various kinds, publishing his Latin poems and his French sonnets called *Les Antiquités de Rome*, in 1558, and his greatest lyrical work, the *Regrets*, in 1559. In the latter year, however, a calumny deprived him of the protection of the cardinal, and threw him into the deepest distress and embarrassment. The nature of this charge is not known, but it must have quickly passed away, for later on in that year we find him preparing a new volume of poems, *Les Jeux Rustiques*, for the press, and nominated archbishop of Bordeaux. He did not live to enjoy this distinction, for on the 1st of January 1560, he died of apoplexy, and was buried in *Nôtre-Dame de Paris*. Like Ronsard he was very deaf.

His collected works did not appear until 1568. The early death of the French Ovid, as he has been called, was a serious loss to European literature, for Joachim du Bellay was at the height of his power, and still rapidly advancing. His poems have a force, an occasional sublimity, and a direct pathos for which we look in vain among his contemporaries; and none but Ronsard excelled him in facility and grace. His most famous poem, *Un Vannier de Blé aux Vents*, one of the loveliest lyrics of the age, was written shortly before his death, and appeared in the *Jours Rustiques* in 1560; it is nominally a paraphrase from the Latin of Nævigerius. The standard edition of the French works of Joachim du Bellay is that published in 2 vols. by Lemercier in 1866, and edited by Ch. Marty-Laveaux. Spenser translated sixty of Du Bellay's Roman sonnets into English, and published them in 1591. A very delicate essay on the poet will be found in Mr W. H. Paton's *Studies in the History of the Renaissance*, 1873.

**BELLE-ISLE-EN-MER**, an island on the W. coast of France, belonging to the department of Morbihan. It is about 10 miles in length by 4 or 5 in breadth, and is divided into the four communes of Palais, Bangor, Porte Philippe, and Locmaria. The inhabitants are principally engaged in agriculture and the fisheries, and in the preservation of sardines, anchovies, &c. The breed of draught horses in the island is highly prized. The chief town, Palais, is a military town of the first class, and possesses a port which is accessible to vessels of 300 tons. It is evident that Belle-isle must have been inhabited from a very early period, as it possesses several rude stone monuments of the class usually called Druidic. The Roman name of the island seems to have been *Vindilia*, which in the Middle Ages became corrupted to *Guedel*. In 1572 the monks of the abbey of St Croix at Quimperlé sold the island to the Retz family, in whose favour it was raised to a marquisate in the following year. From 1761 to 1763 it was held by English troops. Under Napoleon I. the re-fortification of the island was undertaken, but it was never completed. In the state prison of Nouvelle Force at Palais political prisoners have been at various times confined. The population of Palais in 1870 was 3375, of the island rather under 10,000. The lighthouse is situated in 47° 18' 43" N. lat. and 3° 4' 43" W. long.

**BELLEAU, Remy**, French poet of the Renaissance, and member of the Pleiad, was born at Nogent-le-Rotrou in 1528. He became attached to the Elbeufs, and accompanied the head of the family in the expedition against Naples in 1557, where he did good military service. On his return he was made tutor to the young Charles, marquis d'Elbeuf, who, under Belleau's training, became a great patron of the muses. Belleau was extremely learned in the newly-discovered literature of Greece and Rome, and joined the young group of poets with ardour. In 1556 he published the first translation of Anacreon which appeared in French, but this work had no great success. He first became famous through his commentaries to Ronsard's *Amours* in 1560, notes which evinced delicate taste and prodigious learning. Like Ronsard and Du Bellay, he was extremely deaf. His days passed peacefully in the midst of his books and friends, and terminated on the 6th of March 1577. His body was buried in the nave of the Grand Augustins de Paris, and was borne to the tomb on the pious shoulders of four illustrious poets, Ronsard, J. A. de Baif, Philippe Desportes, and Amadis Jamyn. His greatest work is *La Bergerie*, a pastoral in prose and verse, written in a faded rococo style, in imitation of Sannasaro, but containing, as Sainte-Beuve says, some adorable things. Belleau was the French Herrick, full of picturesqueness, warmth, and colour, but of doubtful taste and wanting in

passion. His skies drop flowers and all his air is perfumed, but one becomes weary at last of this excess of sweetness. Extremely popular in his own age, he became undeservedly forgotten in the next. Regnier said, "Belleau ne parle pas comme on parle à la ville;" and his lyrical beauty was lost on the trim 17th century. His complete works were collected in 1578, and contain, besides the Anacreon, *La Bergerie*, and miscellaneous odes and sonnets, a comedy entitled *La Reconnance*, in short rhymed lines, which is not without humour and life. This was one of the earliest productions of the French stage. The best edition of Remy Belleau is that published by Jannet in 1867, in 8 vols., and edited by A. Gouverneur.

**BELLENDEN, JOHN**, a Scotch poet, and the translator of Boece's *History*, was born about the beginning of the 16th century, probably in East Lothian. He appears to have been educated, first at the University of St Andrews and then at that of Paris, where he took the degree of doctor. From his own statement we learn that he had been in the service of James V. from the king's earliest years, and that the post he held was clerk of accounts. It was at the request of James that he undertook his translations of Boece and of Livy. As a reward for his labours he was appointed to the archdeaconry of Moray, and was also made a canon of Ross. Bellenden, who was a strenuous opponent of the Reformation, is said to have died at Rome in 1550. His translation of Boece, which is a remarkable specimen of Scottish prose, distinguished by its freedom and vigour of expression, appears to have been first published in 1536. The best edition is that superintended by Mr Maitland, 2 vols. 4to, Edin., 1821. The same gentleman edited for the first time (Edin., 1823) Bellenden's translation of Livy, which extends only to the first five books. The few poetical remains exhibit considerable taste and skill in versification.

**BELLENDEN, WILLIAM**, a distinguished classical scholar, who flourished during the early part of the 17th century, is said to have been a professor at the University of Paris. Nothing is known with certainty of his life, except that he held the office, probably a sinecure, of Master of Requests. The first of the works by which he is known was published in 1608, with the title *Cicronis Principe, Rationes et Consilia bene gerendi Germanique Imperii, ex iis repetita quae ex Cicronis defluens fontibus in libros xvi. de Statu Rerum Romanarum, qui nondum lucem acceperunt*. It is a laborious compilation of all Cicero's remarks on the origin and principles of regal government, digested and systematically arranged. In 1612 there appeared a similar work, devoted to the consideration of consular authority and the Roman senate, *Cicronis Consilii, Senator, Senatorisque Romanus*. His third work, *De Statu Prisci Orbis*, 1615, is a good outline of general history. All three works were combined in a single large volume, entitled *De Statu Libri Tres*, 1615, which was first brought into due notice by Dr Parr, who, in 1787, published an edition with a preface, famous for the elegance of its Latinity and the vehemence of its politics. The greatest of Bellenden's works is the extensive treatise published posthumously in 1635, *Guidani Bellendani Scoti, Magistri supplicium Libellorum Augusti Regis Magna Britanniae, de tribus Luminibus Romanorum libri aedecim*. The book is unfinished, and treats only of the first luminary, Cicero; the others intended were apparently Seneca and Pliny, probably the younger. It contains a most elaborate history of Rome and its institutions, drawn from Cicero, and thus forms a well-arranged storehouse of all the historical notices contained in that voluminous author. It has been suspected that Middleton was indebted for much of the information contained in his *Life of Cicero* to Bellenden's little known work.

**BELLEROPHON** (Βελλεροφών or Βελλεροφόντης), in *Greek Legend*, a local hero of Corinth, but partly also connected with, and partly similar to, Perseus, the local hero of the neighbouring Argos, the points of likeness being such as to suggest that they had originally been one and the same hero, while the difference in their exploits might result from the rivalry of the two towns. Both are connected with the sun-god Helios and with the sea-god Poseidon, the symbol of the union being the winged horse Pegasus. Bellerophon was a son of Glaucus of Corinth, who is spoken of as a son of Poseidon, and in some way himself a marine deity. To account for the name, i.e., "slayer of Belleros," an otherwise unknown hero of this name was invented. But it is by no means certain that "Belleros" is a personal name; it may mean nothing more than "monster."

The first act of Bellerophon was to capture the horse Pegasus, when it alighted on the Acrocorinth to drink at the fountain of Peirene, with a bridle which he found by his side on awaking from sleep beside the altar of Athena, where he had laid himself down on the advice of a seer Polyidus. The goddess had appeared to him in a dream, reached him a golden bridle, and told him to sacrifice a white bull to his father Poseidon. The next incident occurs in *Tiryns*, at the court of Proetus, whose wife, Sthenoboa (or Anteia, as Homer calls her), falling to seduce Bellerophon, charges him with an attempt on her virtue (*Iliad*, vi. 150-211). Proetus now sends him to Iobates, his wife's father, the king of Lycia, with a letter or sealed tablet, in which were instructions, apparently by means of signs, to take the life of the bearer. Arriving in Lycia, he was received as a guest and entertained for nine days. On the tenth, being asked the object of his visit, he handed the letter to the king, whose first plan for complying with it was to send him to slay the Chimæra, a monster which was devastating the country. Its forepart was that of a lion, its hindpart that of a serpent; a goat's head sprang from its back, and fire vomited from its mouth. Bellerophon, mounted on Pegasus, kept up in the air out of the way of the Chimæra, but yet near enough to kill it with his spear, or as he is at other times represented, with his sword or with a bow. He was next ordered out against the Solymi, a hostile tribe, and afterwards against the Amazons, from both of which expeditions he not only returned victorious, but also on his way back slew an ambush of chosen warriors whom Iobates had placed to intercept him. His divine origin was now proved; the king gave him his daughter in marriage; and the Lycians presented him with a large and fertile estate on which he lived, and reached the pinnacle of happiness, surrounded by two sons, Isander and Hippolochus, and one daughter, Leodamia. But, as in the case of Hercules, the gods now punished him with frenzy. His son Isander fell in battle; his daughter was slain by Artemis; and he himself wandered in the "plain of madness" (ἄγῆρος ἄγῆρος). The cause of his misfortune, Pindar (*Isthm.*, vii. 44; *Olymp.*, xiii. 91) says, was his ambitious attempt to mount to the heavens on Pegasus.

The early relations between Lycia and Argolis are attested by the tradition that the walls of Mycenæ had been built by Cyclopes from Lycia. In both districts the worship of the sun-god had exercised great influence in very early times. The two most frequent representations of Bellerophon in ancient art are (1) when he slays the Chimæra, and (2) when he departs from Argos with the letter. Among the first is to be noted a terra-cotta relief from Melos in the British Museum, where also, on a vase of black ware, is what seems to be a representation of his escape from Sthenoboa.

**BELLEVILLE**, a city of the United States of America, capital of the county of St Clair in Illinois, situated about 14 miles S.E. of St Louis on a rising ground, in the midst of a fertile district. It is a thriving commercial and manufacturing city, well supplied with water, and in the immediate neighbourhood of coal deposits. Its industrial establishments comprise breweries, flour-mills, distilleries, foundries, and a woollen factory, and it possesses a court-house, banks, a high school, a convent for the education of young ladies, and various other institutions. There is a sufficient number of German inhabitants to maintain one daily and two weekly papers in their native language. Population in 1870, 8146.

**BELLEY**, the capital of an arrondissement in the department of Ain, France, is situated near the Rhone, 39 miles east of Lyons. It is the seat of a bishopric founded in 411, and contains an episcopal palace, a cathedral, an ecclesiastical school, a museum, and a public library. The principal industries are the weaving of cotton goods and the culture of the silk-worm. Important fairs are held for the sale of cattle and horses. In the vicinity are found the best lithographic stones in France. Belley is a place of considerable antiquity, and preserves the remains of a Roman temple. It was the capital of the district of Bugy, which maintained its separate constitution down to the Revolution. The neighbourhood is remarkable for its objects of interest both natural and historical, such as the cascade of Glandieux, the intermitting fountain of Grosin, and the Carthusian abbey at Arvieux and Portes. Population in 1872, 3902.

**BELLINI**, the name of an honourable Venetian family. Three members of this family fill a great place in the history of the Venetian school of painting in the 15th century and at the beginning of the 16th. In their hands the art of Venice was developed from a condition more primitive and archaic than that of any other school in Italy, and advanced to the final perfection of Giorgione and of Titian. The first distinguished member of the family was—

1. **JACOPO BELLINI**. When Gentile da Fabriano, one of the most refined and accomplished of the religious painters of the Umbrian Apennines, came to practise at Venice, where art was backward, several young men of the city took service under him as pupils. Among these were Giovanni and Antonio of Murano, and Jacopo Bellini. The Umbrian master left Venice for Florence in 1432, and the two brothers of Murano stayed behind and presently founded a school of their own. (See **VIVARINI**.) But Jacopo Bellini followed his teacher to Florence in the capacity of *famulus*. It was the time when a new spirit had just broken out in Florentine art, and when the leaders of that school—Ghiberti and Donatello, Andrea del Castagno, Paolo Uccello, Masaccio—had made immense progress in many ways at once,—in the sciences of anatomy and perspective, in classical grace and style, in the truth and sincerity of nature,—so that from them the young Venetian found much more to learn than even from his Umbrian teacher as to the possible perfections of the art. The little evidence left us proves that he made good use of his opportunities. But his works are as rare as the events of his life, after his service in Florence with Gentile da Fabriano, are uncertain. That service presently got him into trouble. The Umbrian, as a stranger coming to paint in Florence, was jealously looked on. One day a group of young Florentines took to throwing stones into his shop, and the Venetian pupil ran out and put them to flight with his fists. Thinking this might be turned against him, he went and took service on board the galleys of the Florentine state; but, returning after a year, he found he had in his absence been tried for assault and condemned in a heavy fine. He was arrested and put in prison, but the matter was afterwards compromised upon a public act of penance to which Jacopo submitted. Whether he accompanied his master to Rome in 1436 we cannot tell, but there is evidence to show that he was practising on his own account in Venice in 1430, and probably as soon as 1427. Neither can we fix the date of his marriage; but it was probably about the time of his return to his native state, for we know that he had grandchildren before 1458. The remainder of his life was spent between Venice, Verona, and Padua. At Venice, besides other work, he painted a great series from the lives of Christ and the Virgin in the church of St John the Evangelist. This has entirely

perished. In the cathedral of Verona there was, until it was destroyed by the barbarism of the 18th century, an important Crucifixion from his hand. In the archbishop's palace of the same city another Crucifixion still remains, but greatly injured. At Padua Jacopo appears to have lived several years, and to have founded there a school which became the rival of the school of Squarcione. There his sons, Gentile and Giovanni, grew up; there his daughter Niccolosia found a husband in Andrea Mantegna, the most famous of the scholars of Squarcione. (See *MANTEGNA*.) In Jacopo Bellini the Venetian school had not yet found its special and characteristic manner. But he holds a position of great importance, as having been the first to fertilise Venetian soil with the science and genius of Florence. From no extant pictures of his can his manner be judged so well as from the book of his sketches, which has become the property of the British Museum. This, in spite of fading and decay, is a unique and invaluable possession, containing a vast number of original studies tinted or drawn with pen or ink, and including compositions from Scripture and the lives of the saints, from classical fable, and from natural history in surprising variety.

2. **GENTILE BELLINI** was the elder of the two sons of Jacopo. To the precise date of his birth we have no clue. Both he and his brother Giovanni served together under their father Jacopo as his pupils as long as he lived. After his death each of them practised his art independently in their native city; but a warm and unbroken affection is recorded to have always subsisted between the brothers. In 1464 Gentile was commissioned to paint the doors of the great organ in St Mark's with figures of the four saints—Mark, Jerome, Theodore, and Francis. The next year he painted for the church of Sta Maria dell'Orto a picture of the apotheosis of Lorenzo Giustiniani, patriarch of Venice. From 1465 until 1474 we cannot trace his occupations with precision, though there are several extant works that can be assigned to the interval. On the 21st of September 1474, he was appointed to restore and renew the existing painted decorations in the hall of the Great Council in the Ducal Palace. These were in part frescoes, the work of his father's master, Gentile da Fabriano. Some of them Gentile Bellini restored, and some were so ruined that he had to destroy them and put in their place new work of his own. The practice of painting in oil upon canvas had lately been brought to Venice by Antonello of Messina. The new medium, besides yielding richer effects, resisted damp and salt better than the old; and all the painters of Venice were eagerly learning its use. Gentile adopted it in the hall of the Great Council. In 1479 the Sultan Mahomet sent word to the Signoria of Venice that he desired the services at Constantinople of a good painter of their state, at the same time inviting the doge to the wedding of his son. The doge declined to go, but the Signoria chose Gentile Bellini to be sent with two assistants at the expense of the state and to paint for the Turk, first electing his younger brother Giovanni to fill his place in the works at the Ducal Palace until he should return. He was admirably received, and painted the portraits of the sultan and many of his officers, besides that picture of the reception of a Venetian embassy by the grand vizier which is now at the Louvre (No. 68). It is a well-known and doubtful story how the sultan alleged that a picture of Gentile's showed an imperfect knowledge of the appearance of the muscles of the neck after decapitation, and to convince the painter had a slave decapitated in his presence, and how this made Gentile uncomfortable and anxious to get away. He returned at the end of 1480, bringing gifts and honours; and from that time he and Giovanni were engaged

together for the state on the decoration of the great hall. Gentile painted there four great subjects from the story of Barbarossa, which unhappily perished in the fire of 1577. It is recorded that in 1486 the young Titian entered his workshop as a pupil. Three of the most important of his works date from the last five or six years of the century, and were done for the school of St John the Evangelist at Venice. They represent the cure of a sick Venetian by a relic of the cross, the procession in honour of the same relic in the piazza of St Mark, and the miracle of the recovery of the relic from the Grand Canal (Academy of Venice, Nos. 543, 555, 529). In 1506 Gentile was so busy as to write that he could not accept a commission proposed by Francesco, marquis of Mantua. The next winter he fell sick, and made his will, bequeathing his father's sketch-book above described to his brother John, on condition that the brother should finish the picture of the Sermon of St Mark which the sick man had then on hand. He died on the 23d of February 1507. It is by his science and spirit in the treatment of animated and dignified processional groups, with many figures and architecture of masterly perspective, that we chiefly know Gentile Bellini. He is a workman of infinite precision, and a fine colourist, though his manner has some of the hardness of the earlier times. To conduct the school of Venice to its final liberty and splendour was the work of his younger brother, the great

3. **GIOVANNI BELLINI**. His birth it is no less impossible to fix with accuracy than that of his brother. His earliest work, done at Padua, shows strongly the stern influence of his brother-in-law Andrea Mantegna. The National Gallery has a Christ on the Mount, painted by Giovanni, probably about 1455, and apparently in direct competition with a picture of the same subject by Mantegna himself, similarly conceived, which belongs to the Baring Gallery. The characteristics of the style formed at Padua by Mantegna and Giovanni Bellini, and maintained by the former all his life, are a great intensity and vehemence of expression, an iron severity and unmatched firmness and strength of draughtmanship; a tendency, in draperies, to imitate the qualities of sculpture; a love of the difficulties of perspective; a leaning towards the antique, which these masters learned to transform and reanimate with a more passionate energy and an austerer strength of their own. Of the two, Bellini is always the more reserved and simple, the more inclined to work from nature and the less from the antique, and he has the richer choice in colour; but there are works in which they are indistinguishable. The period when Bellini painted in this first manner and in *tempera* may be roughly fixed (though there is often great uncertainty as to the dates of his pieces, and though at all times he seems occasionally to have recurred to his early practice) between 1455 and 1472. It is probable that the famous picture of the Circumcision now at Castle Howard, which was repeated more than once by the master himself, and many times over by his pupils and assistants, was painted before this date. The altar pieces on a great scale, which are the noblest monument of his middle period, were certainly painted after it. Of these the chief were the Virgin and Saints, in a chapel of the church of Saints Giovanni and Paolo at Venice, which perished along with Titian's Peter Martyr in the fatal fire of 1867; a great Coronation of the Virgin, in the church of St Dominic at Pesaro; a Transfiguration, now in the museum of Naples; a Virgin and Saints, painted for the church of S. Giobbe, now in the Academy at Venice (No. 36). These, and the multitude of Madonnas and other devotional pictures painted by Giovanni Bellini during the thirty years following his change of manner and adoption of the oil medium, are among the noblest products of the religious art of the world. They stand alone in their union of

splendour with solemnity; they have the manful energy of Mantegna without his harshness, and the richness of Giorgione without his luxury. Succeeding pictures show an increase of this richness, and a character more nearly tender. An altar piece, painted for the church of San Zaccaria, seems to indicate a transition, and that the venerable master is acquiring all the softer splendour and keeping pace with Giorgione and Titian, the young pupils of the school. Nay, at the very close of his career, Bellini left the old devotional cycle in which he had produced works so moving and august, and painted for Alphonso of Ferrara a mythology in the most gorgeous manner of the ripe Venetian school. This is the *Fest of the Gods*, now at Alnwick Castle, a picture to which Titian set the finishing touches, and to which the companion, by Titian himself, is now at Madrid. Bellini died on the 29th of November 1516, full of years and honours. We have seen that he was associated with his brother in the decoration of the Great Hall of the Council in 1479. In 1483 he was appointed *Pittore del Dominio*, and exempted from the charges of his guild. All the painters of the state at one time or another were associated with him or passed through his school. Among the most distinguished of his scholars and assistants who will not need separate mention, we may name Marco Basaiti and Vincenzo Catena, many of whose works pass for their master's. He was the honoured associate of statesmen and men of letters. In 1506, when Albert Dürer visited Venice, where he was subject to some annoyances, he found the noble old man not only the most courteous of the Venetian artists in his reception of a stranger, but the best in his profession ("der best im gemall").

Many pictures in various galleries pass as portraits of one or other of the Bellini. But of those that are styled likenesses of Giovanni, none can be proved authentic, while the only certain portrait of Gentile is a medal by Camello. (Vasari, ed. Lemonnier, vol. v. pp. 1-28; Sansovino, *Ven. descr.*, 125, seq.; Ridolfi, i. 90-99; Crowe and Cavalcaselle, *History of Painting in North Italy*, vol. i. pp. 100-193.) (s. a.)

**BELLINI, LORRENZO**, physician and anatomist, was born at Florence in 1643. After completing his studies in general literature he went to Pisa, where, assisted by the generosity of the grand duke Ferdinand II., he studied under two of the most learned men of that age, Oliva and Borelli, the former of whom instructed him in natural philosophy and the latter in mechanics. He likewise studied medicine under Redi, and mathematics under Marchetti. At the early age of twenty he was chosen professor of philosophy at Pisa, but did not long continue in this office; for he had acquired such a reputation for skill in anatomy, that the grand duke procured him a professorship in that science, and was himself a frequent auditor at his lectures. After a long residence in Pisa, he was invited to Florence and appointed physician to the grand duke Cosmo. He was also made senior consulting physician to Pope Clement XI. Bellini died in 1703, in the sixtieth year of his age. His works were published in a collected form in 1708 (3 vols. 4to), and reprinted in 1732.

**BELLINI, VINCENZO**, one of the most celebrated operatic composers of the modern Italian school, was born at Catania in Sicily November 3, 1802. He was descended from a family of musicians, both his father and grandfather having been composers of some reputation. After having received his preparatory musical education at home, he entered the conservatoire of Naples, where he studied singing and composition under Tritto and Zingarelli. He soon began to write pieces for various instruments, as well as a cantata and several masses and other sacred compositions. His first opera, *Adelson e Salvini*, was performed in 1834

at a small theatre of Naples; his second dramatic work, *Bianca e Fernando*, saw the light two years later at the San Carlo theatre of the same city, and made his name known in Italy. His next work, *Il Pirata*, was written for the celebrated Scala theatre in Milan, to words by Felice Romano, with whom Bellini formed a union of friendship to be severed only by his death. The splendid rendering of the music by Tamburini, Rubini, and other great Italian singers, contributed greatly to the success of the work, which at once established the European reputation of its composer. Almost every year of the short remainder of his life witnessed the production of a new operatic work, each of which was received with rapture by the audiences of France, Italy, Germany, and England, and some of which retain their place on the stage up to the present day. We mention the names and dates of four of Bellini's operas familiar to most lovers of modern Italian music, viz. — *I Montecchi e Capuleti* (1829), in which the part of Romeo has been a favourite with all the great contraltos of the last seventy years; *La Sonnambula* (1831); *Norma*, Bellini's best and most popular creation (1832), and *I Puritani* (1834), written for the Italian opera in Paris, and to some extent under the influence of French music. In 1833 Bellini had left his country to accompany to England the great singer Pasta, who had created the part of his *Sonnambula*. In 1834 he accepted an invitation to write an opera for the national Grand Opera in Paris. While he was carefully studying the French language and the cadence of French verse for the purpose, he was seized with a sudden illness and died at his villa in Puteaux near Paris, September 21, 1835. This unexpected interruption of a career so brilliant sheds, as it were, a gloom of sadness over the whole of Bellini's life, a sadness which, moreover, was foreshadowed by the character of his works. His operatic creations are throughout replete with a spirit of gentle melancholy, frequently monotonous and almost always undramatic; but at the same time irresistibly sweet, and almost disarming the stern demands of higher criticism which otherwise would be compelled to reprove the absence of both dramatic vigour and musical depth. To the feature just mentioned, combined with a rich flow of cantilena, Bellini's operas owe their popularity, and will owe it as long as the audiences of our large theatres are willing to tolerate outrages on rhyme and reason if sung by a beautiful voice to a pleasing tune. In so far, however, as the defects of Bellini's style are characteristic of the school to which he belongs, they fall to be considered in a general treatment of the whole subject. See **MUSIC**.

**BELLINZONA**, or **BELLEZZA**, one of the three towns which are the capital in turn of the Swiss canton of Tesin or Ticino. It is built on two hills, one on each side of the Ticino at the entrance of the Riviera valley, and is so situated as completely to bar the passage by that route between Italy and Germany. Its fortifications, which were of great strength during the Middle Ages, have been partially restored. There are three castles, the Castello Grande, Corbario, and Di Mezzo, which belonged to the three cantons of Uri, Unterwalden, and Schwyz respectively; the first of these is now used as an armoury and prison. The abbey church is a fine building of the 16th century, and contains some paintings of value. The Augustinian convent is now used as a Government house. The inundations of the river are prevented from injuring the town by a large dyke, built by the French in the reign of Francis I. A considerable transit trade is carried on with Italy, and there is a famous manufacture of *acqua di cedro* from the blossom and rind of the orange. Bellinzona was in existence at least as early as 1242, when it was conquered by Otto Visconti. It was long an object of contest between the Swiss and the



Milanese; in the 15th century it was the scene of a famous battle, in which the Swiss were defeated; and it finally passed into the hands of the three cantons of Uri, Unterwalden, and Schwyz after the battle of Marignano in 1515. Population in 1870, 2051.

**BELLMAN, KARL MIKAEL**, the greatest lyrical poet of Sweden, was born at Stockholm on the 4th of February 1740. His father, who held a responsible official position, was descended from a family that had already distinguished itself in the fine arts; his mother, a gifted and beautiful woman, early instructed him in the elements of poetry and music. When quite a child he suddenly developed his extraordinary gift of improvising verse, during the delirium of a severe illness, weaving wild thoughts together lyrically, and singing airs of his own composition. From this time he gave himself up to the poetic art, and received great encouragement from the various eminent men who met round his father's table, among whom was Dalin, the favourite poet of the day. As early as 1757 he published a book of verse, a translation of Schweidnitz's *Evangelical Thoughts of Death*, and for the next few years wrote a great quantity of poems, imitative for the most part of Dalin. In 1760 appeared his first characteristic work, *The Moon*, a satirical poem, which was revised and edited by Dalin. But the great work of his life occupied him from 1765 to 1780, and consists of the collections of dithyrambic odes known as *Fredman's Epistles* and *Fredman's Songs*. These were not printed until 1790. The mode of their composition was extraordinary. No poetry can possibly smell less of the lamp than Bellman's. He was accustomed, when in the presence of none but confidential friends, to announce that the god was about to visit him. He would shut his eyes, take his zither, and begin to improvise a long Bacchic ode in praise of love or wine, and sing it to a melody of his own invention. The genuineness of these extremely singular fits of inspiration could not be doubted. The poems which Bellman wrote in the usual way were tame, poor, and without character. The *Fredman's Epistles* glow with colour, ring with fierce and mysterious melody, and bear the clear impress of individual genius. These torrents of rhymes are not without their method; wild as they seem, they all conform to the rules of style, and among those that have been preserved there are few that are not perfect in form. The odes of Bellman breathe a passionate love of life; he is amorous of existence, and keen after pleasure, but under all the frenzy there is a pathos, a yearning that is sadder than tears. The most dissimilar elements are united in his poems; in a bacchical hymn the music will often fade away into a sad elegiac vein, and the rare picturesqueness of his idyllic pictures is warmed into rich colour by the geniality of his humour. He is sometimes frantic, sometimes gross, but always ready, at his wildest moment, to melt into reverie. A great Swedish critic has remarked that the voluptuous joviality of Bellman is, after all, only "sorrow clad in rose-colour," and this underlying pathos gives his poems their undying charm. His later works, *The Temple of Bacchus*, a journal called *What you Will*, a religious anthology entitled *Zion's Holiday*, and a translation of Gellert's *Fables*, are comparatively unimportant. He died on the 11th of February 1795. Several statues exist of Bellman. One represents him naked, crowned with ivy, and striking the guitar; the best is the splendid colossal bust by Byström, which adorns the public gardens of Stockholm, which was erected by the Swedish Academy in 1829. Bellman had a grand manner, a fine voice, and great gifts of mimicry, and was a favourite companion of King Gustavus III. The best edition of his works is one lately published at Stockholm, edited by J. G. Carlén.

**BELLONA**, in *Roman Mythology*, the goddess of war, corresponding to the Greek Enyo, and called now the sister or daughter of Mars, now his charioteer or his nurse. Her worship appears to have been promoted in Rome chiefly by the family of the Claudii, whose Sabine origin, together with their use of the name of "Nero," has suggested an identification of Bellona with the Sabine war goddess Nerio. Her temple at Rome, founded by Appius Claudius Cæcus, 296 a.c., stood in the Campus Martius, near the Flaminian Circus, and outside the gates of the city. It was there that the senate met to discuss the claims of a general to a triumph, and to receive ambassadors from foreign states. In front of it was the *columna bellica* where the ceremony of declaring war was performed. From this native Italian goddess is to be distinguished the Asiatic Bellona, whose worship was introduced into Rome from Comana, in Cappadocia, apparently by Sulla, to whom she had appeared, urging him to march to Rome and bathe in the blood of his enemies. For her a new temple was built, and a college of priests (*Bellonarii*) instituted to conduct her fanatical rites, the prominent feature of which was to lacerate themselves and sprinkle the blood on the spectators. To make the scene more grim they wore black dresses from head to foot.

**BELLOT, JOSEPH RENÉ**, one of the heroes and victims of Arctic exploration, was born at Paris, March 18, 1826. At the age of fifteen he entered the Naval School, in which he studied two years, and earned a high reputation. He distinguished himself in the French expedition of 1845 against Tamatave in Madagascar; and although he was not yet twenty he received the cross of the Legion of Honour at the close of that year. He was afterwards attached to the staff of the station, was promoted to the rank of *Enseigne de Vaisseau* in November 1847, and in 1851 obtained permission to join the English expedition then preparing to go out, under the command of Captain Kennedy, in search of Sir John Franklin. On this occasion he displayed great courage, presence of mind, and self-devotion, rendered important services, and made the discovery of the strait, which bears his name, between Boothia Felix and Somerset Land. Early in 1852 he was promoted lieutenant. In the same year he accompanied, as a volunteer, the expedition sent out by the English Government under Captain Inglefield on the same quest. His intelligence, his devotion to duty, and his courage won him the esteem and admiration of all with whom he was associated. While making a perilous journey with two comrades across the ice, for the purpose of communicating with Captain Inglefield, he was overtaken by a storm, August 21, and being blown into an opening between the broken masses of ice was seen no more. A pension was granted to his family by the Emperor Napoleon III., and an obelisk was erected to his memory in front of Greenwich Hospital.

**BELLOWS AND BLOWING-MACHINES** are machines for producing a current of air, chiefly in order to assist the combustion of a fire.

The common bellows now in use probably represents one of the oldest contrivances for this purpose. It consists of two flat boards, of oval or triangular shape, connected round their edges by a piece of leather so as to form an air chamber. The leather is kept from collapsing, on separation of the boards, by two or more hoops, which act like the ribs in animals. The lower board has a hole in its centre covered inside by a leather flap or valve opening inwards; it has also fastened to it a metal pipe or nozzle, of smaller aperture than the valve. On raising the upper board, the air from without lifts the valve and enters the cavity; then on pressing down the top board, this air is compressed, shuts the valve, and is driven through the pipe with a velocity corresponding to the pressure.

The blast here is, of course, not continuous, but in puffs,—a certain interval being needed for refilling the bellows after each discharge. This drawback was remedied by the invention of double bellows. To understand their action, it is only necessary to conceive an additional board with valve, like the lower board of the single bellows, attached by leather under this lower board. Thus two similar cavities are obtained, separated by the lower board of what was the single bellows. The lowest board is held down by a weight, and another weight presses the top board. When the lowest board is raised it forces air into the upper cavity, and the valve of the middle board prevents return of this air. The lowest board being then depressed, air enters the lower cavity from without, and this in its turn is next forced into the upper cavity. The weighted top board is meanwhile continuously pressing the air of the upper cavity through the nozzle. While the blast thus obtained is continuous, it is not wholly free from irregularities.

The common smiths' bellows, made on the principle just indicated, are generally of circular form, as shown in figs. 1 and 2. A is the blast pipe, B the movable lowest

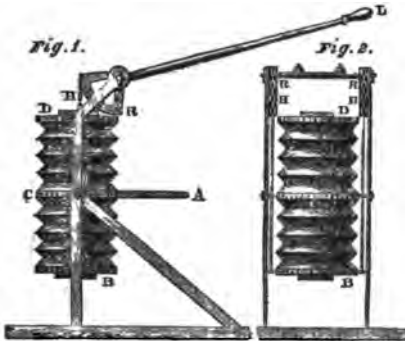

FIGS. 1 AND 2.—COMMON SMITHS' BELLOWES.

board, C the fixed middle board (into which the pipe is inserted), and D the movable upper board pressed by a weight. The lowest board is moved by means of the lever L and the chain H working on the roller R. The weight required to produce a certain force of blast is easily determined; if the diameter of the bellows be 1 foot, the area will be 113.19 inches, and the upper board will require a weight of 56.5 lb for a blast equivalent to a pressure of  $\frac{1}{2}$  lb on the square inch, or a velocity of 207 feet per second, which is well suited for a smith's forge. By a simple arrangement for altering the diameter of the pipe the force of the blast may be varied.

It may be noted that in some parts of the Continent a simple form of bellows is made of two wooden boxes, each open on one side, and the one just fitting into the other. The open sides being opposed to each other, the upper enclosing box is made to move up and down over the other, with which it is jointed at one part, and which is provided with a nozzle, and a valve opening inwards. The change of capacity produces a blast. There is considerable loss of air, however, from the boxes not exactly fitting.

The blowing-machines now almost exclusively used for blast furnaces are of the cylinder and piston type (which is the principle adopted, it may be remarked, in a small hand bellows used by the Chinese). At first the blowing cylinders were single-acting, that is to say, they had the power of propelling a blast only when the piston was moving in one direction. With two or more of these blowing cylinders attached to one crank-shaft, worked by

a water-wheel, a tolerably steady pressure of air was obtained. But in these and other respects considerable progress has been realised.

The cylinder-engines of the present day (which are generally driven by steam) may be classed in two chief systems, according as the cylinder is placed horizontally or vertically. In the former case the steam and blast cylinders are usually in one line, the same rod carrying the pistons of both, and being guided on both sides, while a fly-wheel is employed as regulator. In the vertical systems the steam and blowing cylinders are sometimes similarly connected, but, in the larger engines, they are generally placed one at each end of a beam connecting their pistons. The vertical engines have been most popular in England and in some parts of the Continent (as Silesia), but the other type (almost exclusively used in Westphalia and on the Rhine) is now adopted in several English works.

The general action of many of these machines may be illustrated by the large blowing engine at the Downish iron-works, erected in 1851. Fig. 3 is a representation of

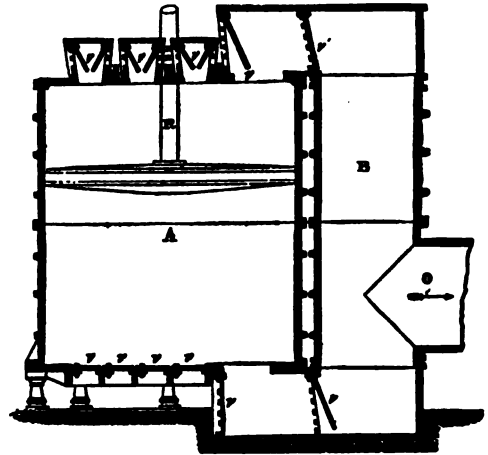

FIG. 3.—SECTION OF CYLINDER OF BLOWING ENGINE.

its blast cylinder, the piston of which, made air-tight by packing, is moved by the oscillating beam of the engine. The cover of the cylinder, and also its bottom, have several openings, furnished with valves *v*, which open inwards. Other valves *v'*, above and below, open into a lateral chamber B, which is connected by the aperture O to the different tuyeres of the furnace. Suppose, now, the piston is at the top and begins to be forced down. The air in the upper part of the cylinder becomes more and more rarefied, and the difference of density between it and that of the blast in chamber B, causes the upper valve *v'* to be applied firmly to the metallic surface before which it is hung. The upper valves *v*, on the other hand, will be raised by the external air which enters to compensate the rarefaction. The same motion of the piston compresses the air below it, causing the lower valves *v* (which open inwards) to be firmly closed, while the valve *v'* will be raised and admit the air into chamber B, whence it passes to the furnace. When the piston is raised the reverse takes place; the lower portion of the cylinder receives air from without, and the upper discharges its air through the pipes leading to the furnace. Thus a nearly continuous flow is obtained. To ensure regularity the pipe O is made to communicate with a closed reservoir of wrought iron, where the variations are destroyed by the elasticity of the air itself. The cylinder here figured is 144 inches in diameter, with a stroke of 12 feet, and discharges about

44,000 cubic feet per minute, at a pressure of  $3\frac{1}{2}$  lb to the square inch.

Where it is desirable to make small blast engines do the work of large ones, compensating smallness of size with velocity, it becomes necessary that the air valves be moved otherwise than by the simple action of the air itself. The best form of such an arrangement is that devised by Mr Slate, in which there is an annular slide valve placed outside the blast cylinder; it receives its motion from a crank connected with the fly-wheel shaft. Thus, with lap and lead of the valve properly proportioned, a high velocity can be attained, and the tremor and jar that are observable in some of the larger engines are entirely absent. Two such engines working together, with their cranks at right angles, give such a uniform blast that no regulator of any kind is needed. In Fossey's engine, which appeared in the Exhibition of 1862, the slide valves are replaced by discs with radial perforations, which are put in slow rotatory motion by gearing connected with the main shaft.

The blast engines with slide valves, however, have not proved so advantageous in practice as was anticipated, owing to the large amount of friction on the valve surfaces, greater liability to derangement, and the wear and tear resulting from such rapid motion.

As a recent example of engines of the vertical type, with steam and air cylinders in one line (which have now come a good deal into use in the north of England) we may briefly notice the compound cylinder blowing engines at the Lackenby Iron-Works, Middleborough. These engines were described by Mr Alfred Hill before the Institution of Mechanical Engineers in 1871. Fig 4 (copied from the drawings by permission of the Institute and of Mr Hill) presents them in vertical section.

They consist of a high pressure non-condensing engine and a low pressure condensing engine, the latter supplied by steam from the former,—this arrangement being adopted for economical reasons. A is the high pressure cylinder (32 inches in diameter) and C the low pressure (80 inches). Both engines have a stroke of 54 inches; and a peculiarity is that they are coupled by cranks placed directly opposite each other instead of, as usual, at right angles,—a light fly-wheel being relied on to carry them over the dead centres. This secures a better balance of the engines, and expansion of the steam in both cylinders in the most advantageous manner; it also obviates the danger of breakages common in the case of right-angle cranks, which probably arises from the tendency to sudden acceleration of one engine over the other at the commencement of each stroke,—full steam pressure being then upon both pistons simultaneously, whilst the resistance of the blast pressure is acting against only one of the blowing pistons. In the blowing cylinders B, the inlet-valves in the bottom are circular disc valves of leather, eighteen in number. The inlet valves T on the top of the cylinder are arranged in ten rectangular boxes, having openings in their vertical sides, inside which are hung leather flap valves. The box covers are made hollow, and are carried down between the backs of the leathern flaps (so as to diminish the air-space as much as possible). The outlet valves *o* for air are ten in number, at each end of the cylinders, and are hung against flat gratings, which are fixed round the circumference of the cylinder. Enclosing each cylinder is an air-tight wrought-iron case M, into which the blast is delivered, and a branch at one side (not shown in figure) conveys the blast to the main. The area of the inlet valves is 860 square inches, or about  $\frac{1}{4}$ th the area of the piston; that of the outlet valves is about  $\frac{1}{4}$ th. For details of the balanced slide valves of the steam cylinders, the surface condenser D, the circulating pump E, the air-pump F, the feed pumps G, &c., we must refer to Mr Hill's paper.

The capacity of each blowing cylinder is 157 cubic feet; consequently, the total quantity of blast supplied from both



FIG. 4.—Vertical Section of Lackenby Blowing Engines.

cylinders at the regular speed of 24 revolutions per minute is 15,072 feet per minute, measured at atmospheric pressure; thus the supply of blast, including loss by leakage, amounts to 190,000 cubic feet per ton of iron made. The pressure of blast in the blast-main is very free from fluctuations,—owing, doubtless, to its large size,  $12\frac{1}{2}$  times the joint capacity of the two blowing cylinders. The indicated power of the engine is found to give a total of 290 horse; that of the two blowing cylinders 258.

Among the more powerful blowing engines of piston and cylinder type at present in use, may be mentioned, besides that at Dowlais referred to above, those of Woolwich dockyard, employed for supplying air to forty forge fires, the Kirkless Hall engines, constructed from Robert Wilson's designs for the Wigan Iron and Coal Company, and the seven engines of Schneider and Co. at Creusot, three of which are horizontal engines of an old type, and the other four direct-acting vertical engines. Descriptions of these will be found in various standard works on metallurgy and engineering. For a description of the large blowing and exhausting engines lately constructed for the new Post Office in London, see *Engineering*, 20th February 1874.

An ingenious mode of obtaining a blast is adopted in Savoy, Carniola, and in some parts of America; it is the *trompe* or water-blowing engine. A flow of a few yards of water is required. From the bottom of a reservoir of water is admitted, by removal of a plug from a conical-shaped aperture, into a large vertical wooden pipe, which terminates below in a wind chest. The water, falling

in streamlets, carries down with it air drawn in through sloping holes near the top of the pipe. The wind chest below has an opening for escape of the water, and the air passes out from another part, in a regular stream, by a nozzle pipe. To facilitate separation of the water and the air, it is found advantageous to fix a small platform under the bottom of the pipe, on which the water may impinge in its fall. The tension of the blast is determined by the height from which the water falls; but this height seldom exceeds 27 feet, which gives a pressure of from  $1\frac{1}{2}$  to 2 lb to the square inch. While the blast obtained is very equal, there is the serious drawback that the air supplied is always more or less laden with moisture. The action of the *trompe* has been investigated by Mr Rodwell (*Philosophical Mag.*, 1864, 1867).

Another kind of blowing engine, in which water is employed, is that invented by Mr Street; in its simpler form it consists of a barrel-shaped vessel, supported horizontally by the two ends of its axis. The cylinder is divided longitudinally by a plane extending from the middle of the internal surface above (the barrel being in its position of rest) to near the opposite side. Suppose the cylinder partly filled with water and made to turn a little way round on its axis, the air on one side will be compressed by the water, while that on the other will be rarefied. A valve opening outwards from the condensed side admits the air to a cavity from which a nozzle pipe proceeds, while a valve opening inwards on the rarefied side admits external air. With additional and corresponding valves, the process is repeated on the reverse oscillation of the cylinder. Thus by swinging the cylinder from side to side, by a crank and rod connected with the engine, alternate puffs of air are propelled into a regulative air chest of special construction, which then supplies a steady blast.

*Fan-blast machines* are frequently employed, especially to urge the fire of steam boilers, and in puddling and reheating, and in the cupola furnaces where anthracite is burnt, or coke used for remelting pig-iron in foundries. In one common form the fan consists of four spokes of a rimless wheel, tipped with vanes and made to rotate in a cylindrical chest, in which it has often a slightly eccentric position. There are openings on both sides round the spindle for admission of air, which, sucked in by the centrifugal action of the fan as it quickly rotates, flows towards the vanes, and is driven through an exit pipe attached to another part of the cylinder.

There are numerous varieties of these engines. An American machine, introduced into England a few years ago by Mr Ellis, has found considerable favour. It is represented in section in fig. 5. It consists of an iron cylindrical casing A, open about a fourth part of its circumference (a to b) for admission of air, and an exit pipe B. Inside the casing is another cylinder, placed eccentrically to it, and which always fits close up against the wooden packing C. This cylinder acts as driver for the three fan blades or pistons D, which are capable of passing out and in through longitudinal slits in its circumference. There is a shaft passing through the small cylinder, and concentric with it at the ends, but cranked in the middle part so as to become concentric with the casing. The inner cylinder revolves round the axis of the ends of the shaft, and on the cranked part revolve the fan blades or pistons, driven by the cylinder. The outer extremities of the fan blades follow closely the inside face of the casing. The crank is placed opposite to the point where the inner cylinder touches the inside of the casing, always retaining, it must be remembered, the same position; when passing this point, the blades are wholly withdrawn inside the cylinder, but when passing the opposite point they are thrust out to the fullest extent, and are always working into or out of the inner cylinder as it revolves. The air

is thus continually being drawn in at the upper opening compressed, and delivered by the lower one.

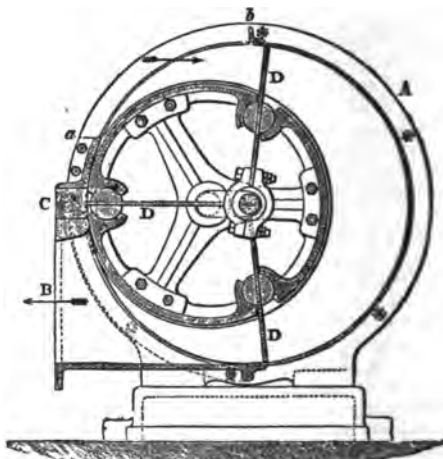

FIG. 5.—Section of an American Blowing-Machine.

The rotary blower, invented by Messrs Root of Connersville, Ind., is one which has of late years found extensive use both in America and Europe. The arrangement differs in some essential features from that of the ordinary fan; it acts by regular displacement of the air at each revolution, as shown in fig. 6. A pair of horizontal shafts geared together at both ends traverse a case of the form of two semi-cylinders separated by a rectangle equal in depth to the diameter of the semi-cylinders, and in width to the distance between the centres of the shafts. These shafts carry a pair of solid arms, each having a section somewhat resembling a figure of eight;

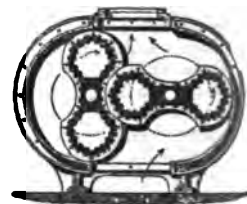

FIG. 6.—Rotary Blower.

the action of which, as they revolve, takes the air in by an aperture at the bottom of the machine, and expels it with considerable pressure, if required, at the top. The gearing outside serves merely to keep the revolving pieces in their proper position, and the power is applied directly to each shaft. One of these machines, employed to give the blast in a pneumatic railway under Broadway, New York, delivers, when worked to maximum speed, a volume of 100,000 cubic feet of air per minute. The engine is also much used in the Bessemer steel-works of this country.

Among the exhibits at a recent exhibition of the Franklin Institute in America, was shown a new form of blower, acting much on the same principle as the Root blower, but, according to the report of the committee, offering certain advantages over the latter. From a cross section of the chamber it appears that three drums of equal size are enclosed in it, two in a line below and one above; the upper one is provided with wings, and the two lower have wide slots along their entire length, allowing the wings to enter in the course of rotation. The function of the two lower drums is to supply alternately abutments to prevent the escape of the air. They are caused to revolve in proper relation with the motion of the upper drum by spur-wheels on the journals, which mesh into another spur-wheel on the shaft of the upper drum. In the moving parts of this machine there are no parts that come into actual contact except the teeth of the spur-wheels. The report allows the

superiority of this rotary blower of Baker, *inter alia*; as regards durability, little pulsation, absence of internal friction and of the need of lubrication, suitability for blowing either hot or cold air, and less power required for the amount of air discharged. A fuller account of it will be found in the *American Artisan* for March 1875.

For the arrangement of bellows in organs see the article ORGAN.

**BELLUNO**, the ancient *Belunum*, is the capital of a province of Northern Italy, and the seat of a bishop, situated at the confluence of the Piave and the Ardo, in long. 12° 8' 46" E. and lat. 46° 7' 46" N. Besides the cathedral, which was built by Palladius, there are fifteen churches, a theological seminary, a gymnasium, a theatre, and a library. A society of arts and sciences and a chamber of commerce have their meetings in the city. Water is supplied from the neighbouring hills by a remarkable aqueduct. The principal industries are the manufacture of silk, wax, leather, and pottery; and a considerable trade is carried on in wood. Population, 15,509.

**BELON**, **PIERRE**, French naturalist, was born about 1517 at the hamlet of Sculletière, in Maine. He studied medicine at Paris and took the degree of doctor. He afterwards travelled in Germany, and heard some lectures at the famous University of Wittenberg. On his return to France he was taken under the patronage of the Cardinal de Tournon, who furnished him with means for undertaking an extensive scientific journey. Belon started in 1546, travelled through Greece, Asia Minor, Egypt, Arabia, and Palestine, and returned in 1549. A full account of his travels, with illustrations, was published in 1553. It passed through several editions, and was translated into Latin and German. Belon, who was highly favoured both by Henry II. and by Charles IX., was assassinated one evening in April 1564, when coming through the Bois de Boulogne. Besides the narrative of his travels he wrote several scientific works of considerable value, particularly the *Histoire Naturelle des Etranges Poissons*, 1551, and *L'Histoire de la Nature des Oyseaux*, 1555.

**BELPASSO**, a town of Sicily, on the slopes of Etna, in the province of Catania, and about 8 miles from the city of that name. In 1669 it was destroyed by an eruption. The inhabitants rebuilt their town on a new site at Mezzo Campo, but, finding the locality unhealthy, they afterwards returned to their original position. Population, 7620.

**BELPER**, a market-town of Derbyshire, situated on the banks of the Derwent, which is here crossed by a stone bridge. It is 7 miles north of Derby, on the Midland Railway. For a considerable period one of the most flourishing towns in the country, it is principally indebted for its prosperity to the establishment of cotton-works by Messrs Strutt in 1777. It also manufactures linens, silks, hosiery, nails, and earthenwares; it has three churches, several chapels for Independents, Methodists, Baptists, &c., a mechanics' institution, and a subscription library. In the neighbourhood are the remains of a mansion where John of Gaunt used to reside. Population (1871), 8527.

**BELSHAM**, **THOMAS**, a Unitarian clergyman, was born at Bedford in 1750. He was educated at the Dissenting Academy at Daventry, where for seven years he acted as assistant tutor. After three years spent in a charge at Worcester, he returned as head of the Daventry Academy, a post which he continued to hold till 1789, when, having adopted Unitarian principles, he resigned all connection with the institution. He superintended during its brief existence a new college at Hackney, and was then called to the charge of the Gravel Pit congregation, which had been formerly held by the famous Priestley. In 1805 he was appointed to the Essex Street chapel, where he remained till his death in 1829. Belsham's first work of

importance, *Review of Mr Wilberforce's Treatise entitled Practical Views*, 1798, was written after his conversion to Unitarianism. His most popular work was the *Evidences of Christianity*; the most important was his translation and exposition of the Epistles of St Paul. He was also the author of a work on philosophy, *Elements of the Philosophy of the Human Mind*, 1801, which is entirely based on Hartley's psychology. Belsham is one of the most vigorous and able writers on the Unitarian side.

**BELSHAM**, **WILLIAM**, brother of the preceding, was born in 1752, and died in 1827. His productions were mainly historical and political writings, advocating the politics of the Whig party. Several detached historical treatises were collected together, and published in 1806 under the title, *History of Great Britain to the conclusion of the Peace of Amiens in 1802*, 12 vols.

**BELSHAZZAR**, the name of a Babylonian prince mentioned in the book of Daniel. According to the account in the fifth chapter of Daniel, Belshazzar was king of Babylon at the time of the capture of the city by the Medes and Persians, and was slain when the city was surprised during a festival. No ancient historian mentions the name of Belshazzar among the successors of Nebuchadnezzar, and there has been considerable controversy as to the identity of the unfortunate monarch. The successors of Nebuchadnezzar, according to the copyists of Berosus, were as follows:—Evil-merodach, two years, son of Nebuchadnezzar; Neriglissar, or Nergalharezar, four years, son-in-law of Nebuchadnezzar; Laborsorarchod, nine months, son of Neriglissar; Nabonidus, seventeen years, not of the royal family. Niebuhr and some others identified Belshazzar with Evil-merodach; other scholars with Neriglissar; and a third section, including Ewald and Browne, identified him with Nabonidus. There is no necessity now to argue against these and similar views, as they are set aside by the Babylonian cuneiform inscriptions, which show that Bel-sar-usur, or Belshazzar, was the name of the eldest son of Nabonidus, the last king of Babylon. In some of his latter inscriptions Nabu-nahid or Nabonidus mentions his eldest son Bel-sar-usur in such terms as to lead to the impression that the young prince was associated with himself on the throne; and this explains several difficulties between the historians and the book of Daniel with respect to the capture of Babylon. After the defeat of the Babylonian forces Nabonidus fled to Borsippa, while the young prince Belshazzar was left in charge of Babylon, the capital, which was closely besieged by the Medes and Persians. The historians all say that Nabonidus, the last king of Babylon, submitted to the conquerors at Borsippa after the taking of his capital, while the book of Daniel states that Belshazzar was slain on the night of the capture of Babylon. These two statements have been supposed to contradict each other, but we now know that they refer to two totally distinct princes whose fates were quite different. The inscriptions of Nabonidus which mention Belshazzar are found on clay cylinders from Mugheir and other Chaldean sites, and they were first discovered and published by Sir Henry Rawlinson, to whom we owe this rectification in ancient history. One of these passages in a prayer reads: "Me Nabu-nahid, king of Babylon, from sin against thy great divinity, do thou save me, and health and long days numerous do thou multiply. And of Bel-sar-usur,—my eldest son, the delight of my heart in the worship of thy great divinity, his heart do thou establish, and may he not consort with sinners." The other texts are after the same form, and give no new details as to Belshazzar,—the account in the fifth chapter of Daniel containing all that is known of his history. The numerous works written on this subject before the discovery of the cuneiform inscriptions are

now of little value; all that is known with any certainty on the matter will be found in Rawlinson's *Great Monarchies*, 2d edition, vol. iii.

**BELT**, **GREAT**, and **LITTLE BELT**, two straits which connect the Baltic Sea with the Cattegat. The former, with a depth of from 5 to 20 fathoms, and a breadth of about 15 miles, runs, from S.S.E. to N.N.W., between the islands of Zealand and Fünen; while the Little Belt, which is only about half as wide, with a narrow entrance from the Cattegat, separates Fünen from the mainland of Schleswig. The navigation of both is rather dangerous for large vessels, owing to the number of sandbanks and small islands; and on that account the Sound, which lies to the east, is the channel preferred by shipping.

**BELTANE**, or **BELTIN**, a festival originally common to all the Celtic peoples, of which traces were to be found in Ireland and the Highlands of Scotland down to the beginning of the present century. The name is compounded of *bel* or *beal*, the Celtic god of light, and *tin* or *teine*, meaning fire. The principal Beltane celebration was held annually in the beginning (generally on the first day) of May, though the name is also applied to a similar festival which occurred in the beginning of November. According to Cormac, archbishop of Cashel about the year 908, who furnishes the earliest notice of Beltane, it was customary to kindle, in very close proximity, two fires, between which both men and cattle were driven, under the belief that health was thereby promoted and disease warded off. (See *Transactions of the Irish Academy*, xiv. pp. 100; 122, 123.) Of the celebration in more recent times an account is given by Armstrong in his *Gaelic Dictionary*, s. v. "Bealtainn." The whole subject is fully treated by J. Grimm in his *Deutsche Mythologie*, c. xx.

**BELÜCHISTAN**. See **BALUCHISTAN**.

**BELVEDERE**, a town of Italy, in the province of Calabria Citra, on the Mediterranean, 32 miles N.W. of Cosenza. It possesses a castle and a maidens' hospital, and is beautifully situated on the slope of a hill. Population between 5000 and 6000.

**BELZONI**, **GIOVANNI BATTISTA**, one of the most enterprising and successful Egyptian explorers, was born of humble parentage at Padua in 1778. When about eighteen years of age he appears to have removed to Rome, and for a short time became a monk. In 1798 the occupation of the city by the French troops drove him from Rome. He wandered through Holland, and in 1803 came to England. Here for some time he was compelled to find subsistence for himself and his wife, an Englishwoman, by exhibiting on the streets athletic exercises and feats of agility. Through the kindness of Mr Salt, who was ever afterwards his patron, he was engaged at Astley's amphitheatre, and his circumstances soon began to improve. In 1812 he set out on his travels, passing through Lisbon and Madrid to Egypt, where his friend, Mr Salt, was British consul. He was desirous of laying before the pasha Mehemet Ali a hydraulic machine for raising the waters of the Nile. Though the experiment with this engine was successful, the design was abandoned by the pasha, and Belzoni resolved to continue his travels. He visited Thebes and removed with great skill the colossal statue, commonly called young Memnon, which he shipped for England. He also pushed his investigations into the great temple of Edfoo, visited Elephantina and Philæ, discovered the temple of Abusimbel, made excavations at Carnac, and opened up a splendid tomb in the Beban-el-Molouk. He was the first to penetrate into the second great pyramid of Ghizah, and the first to visit the oasis west of Lake Moeria. In 1819 he returned to England and published in the following year a most interesting account of his travels and discoveries. He also exhibited for some time at the Egyptian Hall fac-

similes of the great tomb at Beban-el-Molouk. In 1823 he again set out for Africa, intending to penetrate to Timbuctoo. He reached Benin, but was seized with dysentery at a village called Gato, and died December 3, 1823.

**BEMBO**, **PIETRO**, Cardinal, was born at Venice on the 20th of May 1470. While still a boy he accompanied his father to Florence, and there acquired a love for that Tuscan form of speech which he afterwards cultivated in preference to the dialect of his native city. Having completed his studies, which included two years' devotion to Greek under Lascaris at Messina, he chose the ecclesiastical profession. After a considerable time spent in various cities and courts of Italy, where his learning already made him welcome, he accompanied Julio de' Medici to Rome, where he was soon after appointed secretary to Leo X. On the Pontiff's death he retired, with impaired health, to Padua, and there lived for a number of years engaged in literary labours and amusements. In 1529 he accepted the office of historiographer to his native city, and shortly afterwards was appointed librarian of St Mark's. The offer of a cardinal's hat by Pope Paul III. took him in 1539 again to Rome, where he renounced the study of classical literature and devoted himself to theology and classical history, receiving before long the reward of his conversion in the shape of the bishoprics of Gubbio and Bergamo. He died on the 18th of January 1547. Bembo, as a writer, is the beau idéal of a purist. The exact imitation of the style of the genuine classics was the highest perfection at which he aimed. This at once prevented the graces of spontaneity and secured the beauties of artistic elaboration. One cannot fail to be struck with the Ciceronian cadence that guides the movement even of his Italian writings.

His works include a *History of Venice* from 1487 to 1513, dialogues, poems, and what we would now call essays. Perhaps the most famous are a little treatise on Italian prose, and a dialogue entitled *Gli Asolani*, in which Platonic affection is explained and recommended in a rather long-winded fashion, to the amusement of the reader who remembers the relations of the beautiful Morosina with the author. The edition of Petrarch's *Italian Poems*, published by Aldus in 1501, and the *Terzine*, which issued from the same press in 1502, were edited by Bembo, who was on intimate terms with the great typographer. See *Opere di P. Bembo*, Venice, 1729; Cass, *Vita di Bembo*, in 3d vol. of his works.

**BENARES**, a division, district, and city of British India, under the jurisdiction of the Lieutenant-Governor of the N.W. Provinces. **BENARES DIVISION** lies between 24° and 28° N. lat., and 82° and 85° E. long. It is bounded on the N. by Oudh, the Duab, and Bundelkhand; on the E. by Nepal; on the S. by Bengal; and on the W. by Riwa. It comprises the districts of Mirzâpur, Ghâzipur, Azimgârh, Besti, and Gorakhpur; has an area of 18,314 square miles; and a total population in 1872, of 8,178,147, of whom 7,286,415, or 89.1, were Hindus; 889,335, or 10.9, Mahometans; 1797 Christians and others.

**BENARES**, a **DISTRICT** of British India, in the division of the same name, under the jurisdiction of the Lieutenant-Governor of the N.W. Provinces, lies between 25° 7' and 26° 32' N. lat., and 82° 45' and 83° 38' E. long. It is bounded on the N. by the British district of Jaunpur, on the N.E. by Ghâzipur, on the S.E. by Shâhâbâd, on the S. and S.W. by Mirzâpur, and on the W. by Mirzâpur and Jaunpur. The surface of the country is remarkably level, with numerous deep ravines in the calcareous conglomerata. This substratum when burnt affords good lime, and forms an excellent material for roads in its natural state. The soil is a clayey or a sandy loam, and very fertile, except in the tracts called Usur, which are impregnated with soda, nitre, and other salts.

Principal rivers—the Ganges; the Karamnâd, which separates Benares district from that of Shâhâbâd; the Gumti, separating it from Jaunpur and Ghâzipur; the Barna-nâd, which falls into the Ganges near Benares city. Area, 996.19 square miles, of which 788 are under cultivation, 33.89 cultivable but not actually under cultiva-

tion, and the rest uncultivable waste. Population in 1872, 792,699, —90 per cent. being Hindus, 10 per cent. Mahometans, and Christians, &c., numbering 845. Principal crops—wheat, barley, pulse of various kinds, millet, maize, oil-seeds, tobacco, safflower, opium, sugar-cane, and castor-oil, seed. Manufactures—sugar, opium, indigo, cotton cloth, coarse woollens, silk, and leather. Principal roads—(1), from Calcutta to Benares, and thence towards Allahâbâd; (2), a continuation of the Calcutta road through the town of Benares to the Sikrol cantonment, and thence towards Jaunpur; (3), from Ghâsipur to Mirzâpur by Sikrol; and (4), from Benares city to Chankr. The East Indian Railway passes through the district, and the Ganges is navigable all the year round. Gross revenue in 1870-71, £140,617, of which £89,266, or 63 per cent., was derived from land. In 1873-74 the district contained 542 schools, attended by 12,782 pupils. Only two towns in the district contain above 5000 inhabitants, viz., Benares and Râmnagar. The climate of Benares is cool in winter, but very warm in the hot season. Mean temperature in 1872, 77.6° Fahr.; average annual rainfall for the nine years ending 1872, 84.03 inche.

From a very remote period Benares formed the seat of a Hindu kingdom, said to have been founded by one Kâsi Râjâ, 1200 years B.C. Subsequently it became part of the kingdom of Kanauj, which in 1193 A.D. was conquered by Muhammad of Ghor. On the downfall of the Pathân dynasty of Delhi, about 1599, it was incorporated with the Mughal empire. On the dismemberment of the Delhi empire it was seized by Safdar Jang, the Nawâb Vâsir of Oudh, by whose grandson it was ceded to the East India Company by the treaty of 1775. The subsequent history of Benares contains two important events,—the rebellion of Châsit Singh, occasioned by the unjust demands of Warren Hastings for money to carry on the Marhattâ war; and the mutiny of the Native regiments in 1857, on which occasion the energy and coolness of the European officials (chiefly of General Neill) carried the district successfully through the storm.

**BENARES**, the most populous city in the North-Western Provinces, and the headquarters of the commissioner of the division, is situated on the north bank of the Ganges, in 25° 7' N. lat. and 83° 4' E. long. According to the census of 1872, the population amounted to 175,188, viz., 89,763 males, and 85,425 females,—133,549, or 76.23 per cent. being Hindus; 41,374, or 23.77 per cent., Mahometans; others, 265. Gross municipal income in 1871, £16,049; expenditure, £14,331; average rate of municipal taxation, 1s. 10d. per head.

The town of Benares—the religious centre of Hinduism—is one of the most ancient cities on the globe. The Rev. Mr Sherring, in his *Sacred City of the Hindus* (1868), states—"Twenty-five centuries ago, at the least, it was famous. When Babylon was struggling with Nineveh for supremacy, when Tyre was planting her colonies, when Athens was growing in strength, before Rome had become known, or Greece had contended with Persia, or Cyrus had added lustre to the Persian monarchy, or Nebuchadnezzar had captured Jerusalem and the inhabitants of Judea had been carried into captivity, she had already risen to greatness, if not to glory. Nay, she may have heard of the fame of Solomon, and have sent her ivory, her apes, and her peacocks to adorn his palaces; while partly with her gold he may have overlaid the temple of the Lord." Hiouen Thsang, the celebrated Chinese pilgrim, visited Benares in the 7th century A.D., and described it as containing thirty Buddhist monasteries, with about 3000 monks, and about a hundred temples of Hindu gods. Even after the lapse of so great a time the city is still in its glory, and as seen from the river it presents a scene of great picturesqueness and grandeur. The Ganges here forms a fine sweep of about 4 miles in length, the city being situated on the outside of the curve, on the northern bank of the river, which is the most elevated. It is about 3 miles in length, by 1 in breadth, rising from the river in the form of an amphitheatre, and is thickly studded with domes and

minarets. The bank of the river is entirely lined with stone, and there are many very fine ghâts or landing-places built by pious devotees, and highly ornamented. These are generally crowded with bathers and worshippers. Shrines and temples line the bank. The internal streets are so winding and narrow that there is not room for a carriage to pass, and it is difficult to penetrate them even on horseback. Their level is considerably lower than the ground-floors of the houses, which have generally arched rows in front, with little shops behind them; and above these they are richly embellished with verandahs, galleries, projecting oriel windows, and very broad overhanging eaves supported by carved brackets. The houses are built of Chankr stone, and are lofty—none being less than two stories high, most of them three, and several of five or six stories. The Hindus are fond of painting the outside of their houses a deep red colour, and of covering the most conspicuous parts with pictures of flowers, men, women, bulls, elephants, and gods and goddesses in all the multiform shapes known in Hindu mythology. The number of temples is very great; they are mostly small, and are placed in the angles of the streets, under the shadow of the lofty houses. Their forms are not ungraceful, and many of them are covered over with beautiful and elaborate carvings of flowers, animals, and palm branches, rivalling in richness and minuteness the finest specimens of Gothic or of Grecian architecture.

Benares, having from time immemorial been a holy city, contains a vast number of Brâhmins, who either subsist by charitable contributions, or are supported by endowments in the numerous religious institutions of the city. Hindu religious mendicants, with every conceivable bodily deformity, literally line the principal streets on both sides. Some have their legs or arms distorted by long continuance in one position; others have kept their hands clenched until the finger nails have pierced entirely through their hands. But besides an immense resort to Benares of poor pilgrims from every part of India, as well as from Thibet and Burmah, numbers of rich Hindus, in the decline of life, retire thither to pass the remainder of their days, or temporarily to wash away their sins in the sacred water of the Gadgea. These devotees lavish large sums in indiscriminate charity, and it is the hope of sharing in such pious distributions that brings together the concourse of religious mendicants from all quarters of the country.

Besides its religious interest, Benares is important as a wealthy city and a place of considerable trade; the bâzars are filled with the richest goods, and there is a constant bustle of business in all the principal streets. A large trade is carried on in the sugar, saltpetre, and indigo which are produced in the district. Silk and shawls are manufactured in the city; and Benares is especially famous for its gold embroidered cloths, called *Kincoob* (Kincoob), and for its gold filagree work. A large quantity of English piece goods here finds a market, being either sold for consumption in the neighbourhood, or sent to other parts of the country. The principal English institution in Benares is the Government or Queen's College, as it is called, conducted by a staff of professors from England. There are two distinct and separate departments in the college—Sanakrit and English. The Sanakrit college was founded by Government in 1791. There are three missions in Benares—the Church of England, the London, and the Baptist Missionary Society. The mission in connection with the Church of England was established in 1817. The mission has a church capable of holding between 300 and 400 persons, two normal schools for training Christian teachers, a large college, and several girls' schools. The mission of the London Missionary Society was inaugurated in 1821, and is situated in the suburbs of the city. A substantial church was erected

about 1846. The mission of the Baptist Missionary Society was founded in 1817, originally as an outpost of the Serampur mission. It maintains an orphanage for the support and education of native children. With regard to the civil station, which is situated a short distance from the town, Mr Sherring says,—

"The foreign residents of Benares live chiefly at Sikrol, an extensive suburb on the north-west side of the city. This station is divided by the Barná River, to the south of which the greater portion of the military cantonments, and buildings connected therewith, are situated, and likewise the English church, Government college, medical hall, the old mint, the residence of the Mahárájá of Benares, the missionaries of the Church of England and of the London and the Baptist Societies, the courts of the civil and sessions judge, the deputy-judge, and the judge of small causes. To the north of the river are the houses of the civil officers of Government, the courts of the commissioners of the division, and of the collector and other magistrates of the district; several bungalows inhabited by deposed Rájás and other natives; the 'Wards' Institution, for the residence of some of native noblemen under special charge of Government, and while pursuing their studies at Queen's College; the beautiful public gardens, supported by subscription; the swimming bath; the jail, in which as many as 1700 prisoners are sometimes confined; the lunatic asylum, with 110 patients; the blind and leper asylum, with 180 inmates, founded in 1825 by Rájá Kálí Sankár Ghoshál; and the cemetery. A hospital and four dispensaries are situated in various parts of the city, and afford gratuitous relief to numerous patients daily."

**BENAVENTE**, a decayed town of Spain, in the province of Zamora, situated on a gentle eminence near the River Eala. It formerly gave title to the Pimentals, a powerful family of counts, which is now merged in that of the dukes of Osuna. The ancient castle still exists in a ruinous condition. Among the numerous churches, for which the town was once remarkable, are Santa Maria del Asogno, dating from the 12th and 13th centuries, and San Juan del Mercado, which once belonged to the Knights-Templars, and still contains some very old sepulchral monuments. Silk-spinning is carried on by the inhabitants, who number 4536.

**BENBOW, JOHN**, English admiral, the son of a Shropshire gentleman, was born at Shrewsbury about 1650. He went to sea when very young, and at the age of thirty became master of a merchantman. When trading to the Mediterranean in 1686, he beat off a Saltee pirate with such bravery that James II., who took a keen interest in ships and seamen, made him captain of a man-of-war. On the accession of William III. he was employed to protect English commerce in the Channel, a duty which he vigilantly discharged. After taking part with great intrepidity in the bombardment of St Malo (1693), and superintending the blockade of Dunkirk (1696), he sailed in 1698 for the West Indies, where he compelled the Spaniards to restore several English vessels which they had seized. On his return he was appointed vice-admiral, and was frequently consulted by the king. In 1701 he was sent again to the West Indies, a station declined by his seniors from fear of the French strength in these waters. In August 1702 his ship, the "Breda," gave chase off Santa Martha to a French squadron under Du Casse; and although unsupported by his consorts, he kept up a running fight for five days with the most stubborn courage. While boarding the sternmost French vessel he received two severe wounds; and shortly afterwards his right leg was shattered by a chain-shot, despite which he remained on the quarter-deck till morning, when the flagrant disobedience of the captains under him, and the disabled condition of his ship, forced him reluctantly to abandon the chase. After his return to Jamaica, where his subordinates were tried by court-martial, he died of his wounds on November 4, 1702. He possessed inflexible resolution and great naval skill, and secured his high rank through his unaided merits. (*Of: Yonge's Hist. of the British Navy*, vol. i.; *Campbell's British Admirals*, vol. iii.)

**BENCH**, or **BANO**, has various legal significations.

**FREE-BENCH** signifies that estate in copyhold-lands which the wife, being espoused a virgin, has, after the decease of her husband, for her dower, *cum sola et casta fuerit*, according to the custom of the manor. With respect to this free-bench different manors have different customs.

**QUEEN'S BENCH** is one of the three superior courts of Common Law at Westminster, the others being the Common Pleas and the Exchequer. Although for many years these tribunals have possessed co-ordinate jurisdiction, there are a few cases in which each possesses exclusive authority, and in point of dignity precedence is given to the Court of Queen's Bench, the Lord Chief-Justice of which is also styled Lord Chief-Justice of England, and is the highest permanent judge of the Crown. All three courts trace their origin to the *curia regia*. The Court of Exchequer attended to the business of the revenue, the Common Pleas to private actions between citizens, and the Queen's Bench retained criminal cases and such other jurisdiction as had not been divided between the other two courts. By 11 Geo. IV. and 1 Will. IV. c. 70, § 8, the Court of Exchequer Chamber was constituted as a court of appeal for errors in law in all three courts. Like the Court of Exchequer the Queen's Bench assumed, by means of an ingenious fiction, the jurisdiction in civil matters, which properly belonged to the Common Pleas. The functions peculiar to the Queen's Bench are its jurisdiction in criminal matters, and the general control it exercises over inferior magistrates and other public officers. Of late years the court has consisted of one Lord Chief-Justice and five *justices* judges. Under the Judicature Act, 1873, the Court of Queen's Bench becomes the Queen's Bench Division of the High Court of Justice; and appeals will in future be taken to the Court of Appeal instead of the Exchequer Chamber.

The Court of Common Pleas is sometimes called the **COMMON BENCH**.

Sittings in **BANO** (in the courts of Common Law) are the sittings of the full court for the hearing of motions, special cases, &c., as opposed to the *sine die* sittings for trial of facts, where usually only a single judge presides.

**BENCHERS**, in the Inns of Court, the senior members of the society, who are invested with the government of the body to which they belong.

**BENCOOLEN**, the chief town of a Dutch residency in the S.W. of Sumatra. It is situated on the coast at the mouth of a river of the same name, in 3° 50' S. lat. and 102° 3' E. long. The locality is low and swampy, and most of the houses are raised on bamboo piles. The bay is a mere open roadstead fringed with coral reefs, and landing is difficult on account of the surf. A lighthouse has been recently erected by the Dutch authorities. At one time there was a very extensive trade carried on with Bengal, the Coromandel coast, and Java, but it has greatly declined. The principal exports are pepper and camphor. The town, which was formerly 6 miles to the north, was removed to its present site in 1714. It is defended by a fort; and possesses an old and a new government-house, a council chamber and treasury, a hospital, &c. The church was destroyed by an earthquake in 1833. Bencoolen was formerly the chief establishment possessed by the English East India Company in the island, and for a few years constituted a distinct presidency. In 1719 the settlers were expelled by the natives, but were soon permitted to return. In 1760 all the English settlements on the coast of Sumatra were destroyed by a French fleet under Comte d'Estaing. They were afterwards re-established and secured to the British; but in 1825 they were finally ceded to the Netherlands in exchange for the Dutch settlements on the continent of India. Population of the district in 1871, 160 Europeans and 128,343 natives.



**BENDER**, a town of Russia, the capital of a district in the province of Bessarabia, situated on the right bank of the Dniester, 35 miles from Kishineff, in 46° 49' N. lat. and 29° 29' E. long. It possesses three Greek churches, a Roman Catholic church, a dissenting place of worship, four synagogues, and a mosque. Its industrial establishments include a tobacco-factory, candle-works, and brick-kilns. An important trade is carried on by means of its harbour on the Dniester and the road that leads to Odessa,—the greater part of the ships discharging their cargoes here to be conveyed by land to Odessa and Jassy. The principal articles of trade are corn, wine, wool, cattle, tallow, and especially timber, which is floated down the Dniester. The citadel is separated from the town by an eminence, which bears the name of the Suwaroff mound; in its eastern part is a wooden castle with towers. There are also four suburbs to the town, which in 1867 had a population of 24,443, the greater proportion of them being Jews. As early as the 12th century the Genoese had a settlement on the site of Bender. The Moldavians called the place Teegen, and the name of Bender was only bestowed by the Turks in the end of the 14th century. In 1709 Charles XII., after the defeat of Poltava, collected his forces here in a camp which they called New Stockholm, and continued there till 1711. Bender was thrice taken by the Russians,—by Panin in 1770, Potemkin in 1789, and Meyendorff in 1806,—but it was not held permanently by Russia till the Buxarest peace of 1812.

**BANDER-ABBASI**, a town of Persia in the province of Kirman, on the northern shore of the Persian Gulf, in 27° 13' N. lat. and 56° 7' E. long., about 12 miles N.W. of the island of Ormuz. It is surrounded with walls, but the houses are of a very poor description. The old Dutch factory is still standing, and serves as the occasional residence of the Imam of Mascat, to whose domain the town belongs. There is a comparatively small trade in the export of tobacco and fruits and the import of cotton-cloth and pottery. The port is shallow and inconvenient; and it is evident that changes of the coast line by silting up and denudation have considerably altered the character of the place since the time when, under the name of Gombroon, it ranked as one of the first seaports of Persia. In 1612 the Portuguese had established Fort Komoran here, but it was destroyed in 1614, and they were expelled by Shah Abbas I. The English, however, were permitted to build a factory, and about 1620 the Dutch obtained the same privileges. On the capture of the island of Ormuz in 1622 by the English and Persians, a large portion of its trade was diverted to the town, which derived its name of Bander-Abbasi, or *Harbour of Abbas*, from the shah. During the rest of the 17th century the traffic was very great, all the neighbouring nationalities and merchants from the principal countries of Europe frequenting its markets; but in the 18th century this prosperity declined, and most of the trade was removed to Bushire. In 1759 the English factory was destroyed by the French; and though it was afterwards re-established, it has long been abandoned. The ruins of the factory and other buildings lie to the west of the present town. Population about 9000.

**BENEDICT**. St., the founder of the celebrated Benedictine order, is the most illustrious name in the early history of Western monasticism. To him more than to any other the monastic system, which was destined to exercise such an influence for centuries, owes its extension and organization. Benedict was born at Nursia in Umbria about the year 480. He belonged to an old Italian family, and was early sent to Rome to be educated. But the disorder and vices of the capital drove him into solitude while still a youth. It was a time of public peril and social ruin. The Roman empire was crumbling to pieces,

shaken by the successive inroads of barbarians, and a prey to every species of violence and corruption. Young Benedict fled from the wickedness around him. He gave up his literary studies and preferred to be wisely ignorant (*coiseter nocens*). This is the statement of his biographer Gregory the Great, from whom come all the details that we know of Benedict's life. It is needless to say that many of these details are of such a character that it is impossible for modern historical criticism to accept them in their literal meaning. It is of no use, however, trying to disentangle the truth from the falsehood. The reader can easily make allowance for the imaginative exaggerations of the story.

When Benedict fled from Rome he took refuge in a solitary gorge formed by the Anio, in its picturesque course, about 40 miles from the city. There, in a dark inaccessible grotto near Subiaco, he found seclusion and shelter. A neighbouring monk supplied him with food let down by a rope, with a small bell attached, which gave notice of the approach of the food. Once the devil broke the rope, but his malice was foiled by the pliancy ingenuity of the monk. Other and graver dangers assailed him. The Evil One took the shape of a beautiful woman, with whose image the youthful recluse had been familiar in Rome, and so worked upon his senses that he was on the point of abandoning his solitude in search of the beauty which haunted him. But summoning all his fortitude he stripped himself of the vestment of skins which was his only covering, rushed naked amongst the thorns and briars which grew around his retreat, and rolled himself amongst them till he had extinguished the impure flame which devoured him. No impulse of sensual passion ever revisited him. But trials of a different kind assailed him. After spending about three years in retirement a neighbouring convent of monks insisted upon choosing him as their head. He warned them of the severity of the rule he would be bound to exercise, but they would not be dissuaded from their purpose. He had hardly commenced his office, however, when they broke out into fierce resentment against him, and attempted to poison him. The cup containing the poison was no sooner taken into the hands of Benedict than it burst asunder; and, calmly reproving them for their ingratitude, he left them and withdrew once more into his solitude.

By this time, however, the fame of Benedict had spread, and it was impossible for him to remain inactive. Multitudes gathered around him, and no fewer than twelve select cloisters were planted in the lonely valley of the Anio and on the adjacent heights. Young patricians from Rome and elsewhere were attracted to these fraternities; and amongst them one of the name of Maurus (St. Maur), who began to share in popular esteem something of the sanctity and miraculous endowments of Benedict, and who was destined to be his successor. But with increasing fame came also jealousy of his position and duties. A renewed attempt was made by an envious priest to administer poison to the saint; and, miraculous interpositions having again come to his rescue, the same priest, by name Florentinus, had recourse to the diabolical device of sending seven lewd girls within the precincts of the monastery, to seduce the monks by their gestures and sports. Benedict determined to depart from a neighbourhood so full of danger, notwithstanding the long period of thirty years during which he had laboured to consecrate it and spread abroad the blessings of an ascetic Christianity. He journeyed southwards, and at length settled at Monte Cassino, an isolated and picturesque hill near the source of the Liris. There at this time an ancient temple of Apollo still stood, to which the ignorant peasants brought their offerings. Benedict, in his holy enthusiasm, proceeded

to demolish the temple and to erect in its place two oratories, one to St John the Baptist and the other to St Martin, whose ascetic fame had travelled to Italy from the south of Gaul. Around these sacred spots gradually rose the famous monastery which was destined to carry the name of its founder through the Christian world, and to give its laws, as Milman says, "to almost the whole of Western monasticism."

Benedict survived fourteen years after he had begun this great work. His sanctity and influence grew with his years, in illustration of which it is told how the barbarian king Totila, who made himself master of Rome and Italy, sought his presence, and, prostrating himself at his feet, accepted a rebuke for his cruelties, and departed a humbler and better man. His last days were associated with the love and devotion of his sister Scolastica, who too had forsaken the world and given herself to a religious life with an enthusiasm and genius for government hardly less than his own. She had established a nunnery near Monte Cassino; but the rules of the order permitted the brother and sister to meet only once a year. He had come to pay his accustomed visit. They had spent the day in devout converse, and, in the fulness of her affection, Scolastica entreated him to remain, and "speak of the joys of heaven till the morning." Benedict was not to be prevailed upon, when his sister burst into a flood of tears, and bowed her head in prayer. Immediately the heavens became overcast; thunder was heard, and the rain fell in torrents, so that it was impossible for Benedict to depart for the night, which was spent in spiritual exercises. Three days later Benedict saw in vision the soul of his sister entering heaven, and in a few days afterwards his own summons came. He died standing, after partaking of the holy communion, and was buried by the side of his sister.

The **BENEDICTINES**, or followers of St Benedict, were those who submitted to the monastic rule which he instituted. This rule will be generally described in the article on **MONASTICISM**. It is sufficient to say here that its two main principles were labour and obedience. It was the distinction of Benedict that he not merely organized the monks into communities, but based their community-life, in a great degree, on manual labour, in contrast to the merely meditative seclusion which had hitherto been in vogue both in the East and the West. Probably, not even the founder himself foresaw all the prospective advantages of his law, which was destined not merely to make many a wilderness and solitary place to rejoice with fertility, but to expand, moreover, into a noble intellectual fruitfulness, which has been the glory of the Benedictine order. The law of obedience was absolute, but was tempered by the necessity on the part of the superior of consulting all the monks assembled in a council or chapter upon all important business. The abbot or superior was also elected by all the monks, whose liberty of choice was unrestricted. No right of endowment properly subsisted within the monastery; and the vow of *stabilitas* once undertaken after the expiry of the year of novitiate could never be recalled. Food and clothing were of the simplest kind, and all daily regulated; and the intervals of labour were relieved by a continually recurring round of religious service from prime to evensong. The Benedictine rule spread almost universally in the West,—not in rivalry of any other rule, but as the more full and complete development of the monastic system. In France and England especially it took rapid root; and "in every rich valley, by the side of every clear and deep stream, arose a Benedictine 'abbey'—a centre of local good and Christian civilisation. See **ANABY**. (J. x.)

**BENEDICT**. Fourteen popes bore the name of Benedict—

**BENEDICT I.** (573-8) succeeded John III., and occupied

the Papal chair during the incursions of the Lombards, and during the series of plagues and famines which followed these invasions. (Paul. Diacon., *De Gest. Longob.*, ii. 10.)

**BENEDICT II.** (684-685) succeeded Leo II., but although chosen in 683 he was not ordained till 684, because the leave of the Emperor Constantine was not obtained until some months after the election. (Paul. Diacon., *op. cit.* vi. 53.)

**BENEDICT III.** (855-858) was chosen by the clergy and people of Rome, but the election was not confirmed by the Emperor Lothair, who appointed an anti-pope, Anastasius. Benedict was at last successful, and the schism helped to weaken the hold of the emperors upon the popes. The mythical Pope Joan is usually placed between Benedict and his predecessor Leo IV.

**BENEDICT IV.** (900-903).

**BENEDICT V.** (964-965) was elected by the Romans on the death of John XII. The Emperor Otho did not approve of the choice, and carried off the pope to Hamburg, where he died.

**BENEDICT VI.** (972-974) was chosen with great ceremony and installed pope under the protection of the Emperor Otho the Great. On the death of the emperor the turbulent citizens of Rome renewed their outrages, and the pope himself was strangled by order of Crescentius, the son of the notorious Theodora.

**BENEDICT VII.** (975-983) belonged to the noble family of the counts of Tusculum, and governed Rome quietly for nearly nine years, a somewhat rare thing in those days.

**BENEDICT VIII.** (1012-1024), also of the family of Tusculum, was opposed by an anti-pope, Gregory, who compelled him to flee from Rome. He was restored by Henry of Saxony, whom he crowned emperor in 1014. In his pontificate the Saracens began to attack the southern coasts of Europe, and effected a settlement in Sardinia. The Normans also then began to settle in Italy.

**BENEDICT IX.** (1033-1056), the son of Alberic, count of Tusculum, and nephew of Benedict VIII., obtained the Papal chair by simony. He was deposed in 1044, and Sylvester was chosen in his stead. The result was a long and disgraceful schism (*cf.* Mittler, *De Schismate in Eccl. Rom. sub Pontif. Bened. IX.*)

**BENEDICT X.** (1058-9) scarcely deserves to be reckoned a pope. He reigned nine months. It is important, however, to remember that his election is one of the latest made by Roman factions, and under his successor the mode of election by the cardinals was adopted.

**BENEDICT XI.** (1303-1304) succeeded the famous Boniface VIII., but was unable to carry out his Ultramontane policy. He released Philip the Fair of France from the excommunication laid on him by Boniface, and practically ignored the bull *Unam Sanctam*. The popes who immediately succeeded him were completely under the influence of the kings of France, and removed the Papal seat from Rome to Avignon.

**BENEDICT XII.** (1334-1342) succeeded Pope John XXII., but did not carry out the policy of his predecessor. He practically made peace with the Emperor Louis, and as far as possible came to terms with the Franciscans, who were then at war with the Roman see. He was a reforming pope, and tried to curb the luxury of the monastic orders, but without much success. (Baluze, *Vita Pontif. Avinion.*, i.)

**BENEDICT XIII.** Two popes assumed this title—(1.) *Peter de Luna*, a Spaniard, who was chosen by the French cardinals on the death of Clement VII. in 1394. On the death of Urban V. in 1389 the Italian cardinals had chosen Boniface IX.; the election of Benedict therefore perpetuated the great schism. The greater portion of the church refused to recognise him, and in 1397 the French Church, which had supported him, withdrew from allegiance to both popes, and in 1398 Benedict was imprisoned in his own palace at

**Avignon.** The Council of Constance brought this state of matters to an end. Benedict abdicated in 1417, but was recognised by Scotland and Spain until his death in 1424. His name does not appear in the Italian list of popes. (*Of Dupuy, Hist. des Papes, 1378-1428*). (2.) **Vincenzo Marco Orsini**, who succeeded Innocent XIII. in 1724. He at first called himself Benedict XIV., but afterwards altered the title. He was a reforming pope, and endeavoured to put down the luxury of the Italian priesthood and of the cardinalate. He died in 1750.

**BENEDICT XIV. (1740-1758)** belonged to a noble family of Bologna. Elected to the Papal chair in a time of great difficulties, chiefly caused by the disputes between Roman Catholic nations about the election of bishops, he managed to overcome most of them. The disputes of the Holy See with Naples, Sardinia, Spain, Venice, and Austria were settled. Perhaps the most important act of his pontificate was the promulgation of his famous laws about missions in the two bulls, *Ex quo singulari* and *Omnium sollicitudinem*. In these bulls he denounced the custom of accommodating Christian words and usages to express heathen ideas and practices, which had been extensively done by the Jesuits in their Indian and Chinese missions. The consequence of these bulls was that most of the so-called converts were lost to the church.

**BENEFICE**, a term first applied under the Roman empire to portions of land, the usufruct of which was granted by the emperors to their soldiers or others for life, as a reward or *beneficium* for past services, and as a retainer for future service. A list of all such *beneficia* was recorded in the *Book of Benefices (Liber Beneficiorum)*, which was kept by the principal registrar of benefices (*Primicerius Beneficiorum*). In imitation of the practice observed under the Roman empire, the term came to be applied under the feudal system to portions of land granted by a lord to his vassal for the maintenance of the latter on condition of his rendering military service; and such grants were originally for life only, and the land reverted to the lord on the death of the vassal. In a similar manner grants of land, or of the profits of land, appear to have been made by the bishops to their clergy for life, on the ground of some extraordinary merit on the part of the grantees. The validity of such grants was first formally recognized by the Council of Orleans, 511 A.D., which forbade, however, under any circumstances, the alienation from the bishoprics of any lands so granted. The next following Council of Orleans, 533, broke in upon this principle, by declaring that a bishop could not reclaim from his clergy any grants made to them by his predecessor, excepting in cases of misconduct. This innovation on the ancient practice was confirmed by the subsequent Council of Lyons, 566, and from this period these grants ceased to be regarded as personal, and their substance became annexed to the churches,—in other words, they were henceforth enjoyed *jure rectorii*, and no longer *jure personali*. How and when the term *beneficia* came to be applied to these episcopal grants is uncertain, but they are designated by that term in a canon of the Council of Mayence, 813.

The term benefice, according to the canon law, implies always an ecclesiastical office, *propter quod beneficium datur*; but it does not always imply a cure of souls. It has been defined to be the right which a clerk has to enjoy certain ecclesiastical revenues on condition of discharging certain services prescribed by the canons, or by usage, or by the conditions under which his office has been founded. These services might be those of a secular priest with cure of souls, or they might be those of a regular priest, a member of a religious order, without cure of souls; but in every case a benefice implied three things: 1. An obligation to discharge the duties of an office, which

is altogether spiritual; 2. The right to enjoy the fruits attached to that office, which is the benefice itself; 3. The fruits themselves, which are the temporalities. By keeping these distinctions in view, the right of patronage in the case of secular benefices becomes intelligible, being in fact the right, which was originally vested in the donor of the temporalities, to present to the bishop a clerk to be admitted, if found fit by the bishop, to the office to which those temporalities are annexed. Nomination or presentation on the part of the patron of the benefice is thus the first requisite in order that a clerk should become legally entitled to a benefice. The next requisite is that he should be admitted by the bishop as a fit person for the spiritual office to which the benefice is annexed, and the bishop is the judge of the sufficiency of the clerk to be so admitted. By the early constitutions of the Church of England a bishop was allowed a space of two months to inquire and inform himself of the sufficiency of every presentee, but by the ninety-fifth of the canons of 1604 that interval has been abridged to twenty-eight days, within which the bishop must admit or reject the clerk. If the bishop rejects the clerk within that time he is liable to a *duplex querela* in the ecclesiastical courts, or to a *quære in impediri* in the common law courts, and the bishop must then certify the reasons of his refusal. In cases where the patron is himself a clerk in orders, and wishes to be admitted to the benefice, he must proceed by way of petition, instead of by deed of presentation, reciting that the benefice is in his own patronage, and petitioning the bishop to examine him and admit him. Upon the bishop having satisfied himself of the sufficiency of the clerk, he proceeds to institute him to the spiritual office to which the benefice is annexed but before such institution can take place, the clerk is required to make a declaration of assent to the Thirty-nine Articles of Religion and to the Book of Common Prayer according to a form prescribed in the Clerical Subscription Act, 28 and 29 Vict. c. 122, to make a declaration against simony in accordance with that Act, and to take and subscribe the oath of allegiance according to the form in 31 and 32 Vict. c. 72. The bishop, by the act of institution, commits to the clerk the cure of souls attached to the office to which the benefice is annexed. In cases where the bishop himself is patron of the benefice, no presentation or petition is required to be tendered by the clerk, but the bishop having satisfied himself of the sufficiency of the clerk, collates him to the benefice and office. It is not necessary that the bishop himself should personally institute or collate a clerk, he may issue a fiat to his vicar-general, or to a special commissary for that purpose. After the bishop or his commissary has instituted the presentee, he issues a mandate under seal, addressed to the archdeacon or some other neighbouring clergyman, authorising him to induct the clerk into his benefice,—in other words, to put him into legal possession of the temporalities, which is done by some outward form, and for the most part by delivery of the bell-ropes to the clerk, who thereupon tolls the bell. This form of induction is required to give the clerk a legal title to his "*beneficium*," although his admission to the office by institution is sufficient to vacate any other benefice which he may already possess.

By the Lateran Council of 1215, which was received by the Church of England, no clerk can hold two benefices with cure of souls, and if a beneficed clerk shall take a second benefice with cure of souls, he vacates *ipso facto* his first benefice. Dispensations, however, could be easily obtained from Rome, before the reformation of the Church of England, to enable a clerk to hold several ecclesiastical dignities or benefices at the same time, and by 25 Henry VIII. c. 21, the power to grant such dispensations, which had been exercised previously by the court of Rome, was

transferred to the archbishop of Canterbury, certain ecclesiastical persons having been declared by a previous statute (21 Henry VIII. c. 13) to be entitled to such dispensations. The system of pluralities carried with it, as a necessary consequence, systematic non-residence on the part of many incumbents, and delegation of their spiritual duties in respect of their cures of souls to assistant curates. The evils attendant on this system were found to be so great that in 1838 an Act of Parliament, 1 and 2 Vict. c. 106, was passed to abridge the holding of benefices in plurality, and it was enacted that no person should hold under any circumstances more than two benefices, and this privilege was made subject to the restriction that his benefices were within ten statute miles of each other. By a subsequent Act, 13 and 14 Vict. c. 98, the restriction has been further narrowed, and no spiritual person may now hold two benefices except the churches of such benefices are within three miles of each other by the nearest road, and the annual value of one of such benefices does not exceed one hundred pounds. By this statute the term benefice is defined to mean benefice with cure of souls and no other, and therein to comprehend all parishes, perpetual curacies, donatives, endowed public chapels, parochial chapelries, and chapelries or districts belonging or reputed to belong, or annexed or reputed to be annexed, to any church or chapel.

A benefice is avoided or vacated—1, by death; 2, by resignation, if the bishop is willing to accept the resignation; 3, by cession, upon the clerk being instituted to another benefice or some other preferment incompatible with it; 4, by deprivation and sentence of an ecclesiastical court; 5, by act of law in consequence of simony; 6, by default of the clerk in neglecting to read publicly in the church the Book of Common Prayer, and to declare his assent thereto within two months after his induction, pursuant to 13 and 14 Car. II. c. 4, § vi.

The number of benefices with or without cure of souls in the Church of England, before the first statute to abridge pluralities was passed in 1838 (1 and 2 Vict. c. 106), was about 11,000. These benefices were served by some 10,000 clergy, of whom rather more than 5000 were incumbents holding one or more livings, and some of them altogether non-resident; the remainder were assistant curates, for the most part residing in one parish and having full charge of another. The effect of the Pluralities Act in the course of about 30 years has been to produce a remarkable and most salutary change. It was computed in 1867 that the parochial benefices were 12,888 in number, and the parochial clergy 17,869, of whom 4981 only were assistant-curates. The patronage of 6408 of these benefices was in private hands, whilst the patronage of 6486 was at the disposal of the Crown, or of public bodies or public functionaries. An approximate statement of the yearly value of all the benefices in England and Wales, the number of which has undergone a considerable increase since 1867, was drawn up in 1874 by Mr J. K. Aston for a select committee of the House of Lords on Church Patronage. From this statement it appears that the yearly value of all the benefices in public patronage is about £1,825,806, whilst the value of those in private patronage is about £1,893,526; but in Mr Aston's opinion these estimates are below the actual value. (T. T.)

**BENEKE, FRIEDRICH EDUARD**, a distinguished German psychologist, was born at Berlin on the 17th February 1798. He was educated under Bernhardt at the *Gymnasium Fredericianum*, and studied at the universities of Halle and Berlin. He directed his attention in the first instance to theology, coming under the influence of Schleiermacher and De Wette, but afterwards to pure philosophy, studying particularly English writers, and the German modifiers of Kantianism, such as Jacobi, Fries, and Schopenhauer. In 1820 he published his *Theory of Knowledge*, his *Empirical Psychology as the Foundation of all Knowledge*, and his inaugural dissertation *De Veris Philosophia Initio*. In all these writings appeared very strongly his fundamental view, that philosophical speculation must be limited to the facts of inner experience, and that a true psychology, which is the basis of all knowledge, must be formed by treating these facts according to the rigid methods of physical science. His marked opposition to the philosophy of Hegel, then dominant in Berlin, came

to the front still more clearly in the short tract, *New Foundation of Metaphysics*, intended to be the programme for his lectures as *privat-docent*, and in the able treatise, *Ground-work of a Physics of Ethics*, written in direct antagonism to Kant's *Metaphysics of Ethics*, and attempting to deduce ethical principles from a basis of empirical feeling. In the same year (1822) his lectures were prohibited at Berlin, according to his own belief through the influence of Hegel with the Prussian authorities, who also prevented him from obtaining a chair from the Saxon Government. He retired to Göttingen, lectured there for some years, and was then allowed to return to Berlin. In 1832 he received an appointment as *Professor Extraordinarius* in the university, which he continued to hold till his death. On 1st March 1854 he disappeared from his home; and some months later his body was found in the canal near Charlottenburg. There was some suspicion that he had committed suicide in a fit of mental depression.

Beneke was a most prolific writer, and besides the works mentioned above, published large treatises in the several departments of philosophy, both pure and as applied to education and ordinary life. A complete list of his writings will be found in the appendix to Dressler's edition of the *Lehrbuch der Psychologie als Naturwissenschaft*, 1861.

The distinctive peculiarity of Beneke's system consists, first, in the firmness with which he maintained, and the consistency with which he carried out the proposition, that in empirical psychology is to be found the basis of all philosophy; and secondly, in his rigid treatment of mental phenomena by the genetic, or, as Professor Bain has called it, the natural history method. According to him, the formed or perfected mind with its defined faculties is a development from simple elements, and the first problem of philosophy is the determination of these elements and of the laws or processes by which the development takes place. In his *Neue Psychologie* (essays iii., viii., and ix.), he clearly marked out his position with regard to his predecessors and contemporaries, and both there and in the introduction to his *Lehrbuch*, signalized as the two great stages in the progress of psychology the negation of innate ideas by Locke, and of faculties, in the ordinary acceptation of the term, by Herbart. The next step was made by himself, when he insisted that psychology must be treated as one of the natural sciences. As is the case with them, its content is given by experience alone, and differs from theirs only in being the object of the internal as opposed to the external sense. But by a scientific psychology Beneke in no wise meant what is now almost invariably thought of under that designation, a psychology founded on physiology. These two sciences, in his opinion, had quite distinct provinces, and gave no mutual assistance. Just as little help is to be expected from the science of the body as from mathematics and metaphysics, both of which had been pressed by Herbart into the service of psychology. The true method of study is that applied with so much success in the physical sciences,—critical examination of the given experience, and reference of it to ultimate causes, which may not be themselves perceived, but are nevertheless hypotheses necessary to account for the facts. (See on method, *Neue Psych.*, essay i.)

Beneke, therefore, starting from the two assumptions that there is nothing, or at least no formed product, innate in the mind, and that definite faculties do not originally exist, and from the fact that our minds nevertheless actually have a definite content and definite modes of action, proceeds to state somewhat dogmatically his scientifically verifiable hypotheses as to the primitive condition of the soul, and the laws according to which it develops. Originally the soul is possessed of, or is, an immense variety of powers, faculties, or forces (conceptions which Beneke, in opposition to Herbart, holds to be metaphysically justifiable), differing from one another only in tenacity, vivacity, receptivity, and grouping. These primitive immaterial forces, so closely united as to form but one being (essence), acquire definiteness or form through the action upon them of *stimuli* or excitants from the outer world. This action of external impressions which are appropriated by the internal powers, is the first fundamental process in the genesis of the completed mind. If the union of impression and faculty be sufficiently strong, consciousness (not self-consciousness) arises, and definite sensations and perceptions begin to be formed. These primitive sensations, however, are not to be identified with the sensations of the special senses, for each of these senses is a system of many powers which have grown into a definite unity, have been educated by experience. From various facts of ordinary experience it must be concluded that a second fundamental process is incessantly going on, viz., the formation of new powers of faculties, which takes place principally during sleep. The third and most important process results from the fact that the combination between stimulus and power may be weak or strong.

If weak, then the two elements are said to be movable, and they may flow over from one to another of the already formed psychical products. Any formed faculty does not cease to exist on the removal of its stimulus; in virtue of its fundamental property, *tenacity*, it sinks back as a trace (*Spur*) into unconsciousness, whence it may be recalled by the application to it of another stimulus, or by the attraction towards it of some of the movable elements or newly-formed original powers. These traces and the flowing over of the movable elements are the most important conceptions in Bencke's psychology; by means of them he gives a rationale of reproduction and association, and strives to show that all the formed faculties are simply developments from traces of earlier processes. Lastly, similar forms, according to the degree of their similarity, attract one another or tend to form closer combinations.

All psychical phenomena are explicable by the relation of impression and power, and by the flow of movable elements; the whole process of mental development is nothing but the result of the action and interaction of the above simple laws. In general this growth may be said to take the direction of rendering more and more definite by repetition and attraction of like to like the originally indefinite activities of the primary faculties. Thus the sensations of the special senses are gradually formed from the primary sensuous feelings (*Sinnliche Empfindungen*); concepts are formed from intuitions of individuals by the attraction of the common elements, and the consequent flow towards them of movable forms. Judgment is the springing into consciousness of a concept alongside of an intuition, or of a higher concept alongside of a lower. Reasoning is merely a more complex judgment. Nor are there special faculties of judging or reasoning. The understanding is simply the mass of concepts lying in the background of unconsciousness, ready to be called up and to flow with force towards anything closely connected with them. Even memory is not a special faculty; it is simply the fundamental property of tenacity possessed by the original faculties. The very distinction between the great classes, Knowledge, Feeling, and Will, may be referred to elementary differences in the original relations of faculty and impression.

To follow Bencke into the details of any one of his psychological developments would be impossible within moderate compass. It may be sufficient to say, that on nearly all questions concerning the psychical mechanism, his works contain a mass of unusually rich and instructive material. They are particularly deserving of careful comparison with the association psychology of modern British thinkers, most of whose results and processes will be found there thoroughly handled and worked into a comprehensive system.

In logic, metaphysics, and ethics, Bencke's speculations are completely dependent on the results of the psychological analysis. Thus thinking has been by him separated into analytical and synthetical. The first, which consists essentially in the subsumption of one concept under another, is the subject of elementary, pure, or formal logic, which, as an art, has to lay down the universal rules according to which such subsumption takes place. Logical reasoning, which adds nothing to our knowledge, but merely clears it up, is at bottom a substitution of one notion for another. In the elaborate theory of syllogism, founded on this principle, Bencke to some extent anticipates Hamilton's New Analytic. (It cannot, however, be thought that Hamilton borrowed his principle from Bencke, as the latter seems to have suspected;—see Dressler's remark, *Lehrbuch der Psy.*, 290. The two approached the matter from quite different sides, and the peculiarity of Hamilton's system, the definite, explicit, quantification of the predicates, is by no means necessarily implied in anything said by Bencke.) Synthetical thinking, on the other hand, leads to new knowledge, but in its progress it makes use of principles involving the relation of thought to existence, and which, therefore, find justification in metaphysics. In that science Bencke's fundamental proposition is that in inner experience we cognize things as they are, whereas in outer experience we only know their effects. Real being is given in our intuitions, from which we gradually form a notion of self, and then of other conscious beings like ourselves. The inference to the real existence of external things is an unconscious reasoning, involving the same elements as the inference to the existence of other conscious beings. The relations which give definiteness and universality to experience, such as substance and cause, are known directly in inner experience, in the systematic relations of the several psychical elements, and are transferred by us to outer beings. In this part of his metaphysical theory Bencke owes much to Schellhammer.

In his ethical theory, which is worked out with great fulness, and which was, in his own opinion, his most valuable contribution to philosophy, Bencke is thoroughly-empirical. The worth of an object is defined to be the degree of pleasurable feeling with which it affects us, and ethical judgments are founded on the relations of worth among the feelings with which we regard objects. There is a gradation of moral worth, because there are higher and lower faculties; and, as the mental constitutions of all men are fundamentally alike, this gradation of worth becomes a *norm* or general rule for estimating moral qualities. An estimate founded on this normal scale appears as morally necessary, or as duty.

The special value of Bencke's works, as has been already said, consists in the many specimens of acute psychological analysis scattered throughout them. As a complete explanation of psychical facts, the theory seems singularly defective. The original hypotheses, peculiar to Bencke and on which the whole depends, are hastily assumed, are never subjected to critical examination, and after all, like Locke's earlier theory, rest on a clumsy mechanical metaphor. As is the case with all empirical theories of mental development, the higher categories or notions, which are apparently shown to result from the simple elements, are really presupposed at every step. Particularly unsatisfactory is the account of consciousness, which is said to arise from the union of impression and faculty. The necessity of consciousness for any mental action whatsoever is apparently granted, but the conditions involved in it are never discussed or referred to. So too the explanation of the origin of the notions, substance and cause, always a crucial test for an empirical theory, is completely irreconcilable with the fundamental principle of the system. The same defect appears in the account of ethical judgment; no amount of empirical fact can ever yield the notion of absolute duty. It is not, perhaps, to be altogether attributed to the ideal character of German speculation, that Bencke has been almost entirely neglected, and that his results have found acceptance mainly with practical teachers. Undoubtedly, for the science of education his minute analysis of temperament and careful exposition of the means whereby the young, unformed mind may be trained are of infinite value; but the truth of many of his doctrines on these points lends no support to the fundamental hypotheses, from which indeed they might be almost entirely severed.

Among German writers, not professed followers of Bencke, but who have been largely influenced by him, may be mentioned Ueberweg (particularly in the first part of his *Logik* and *Fortlage*). In England, perhaps the only writer who shows traces of acquaintance with his works is Morell (*Introduct. to Mental Philosophy*). The most eminent members of the school are Dressler (whose *Bencke oder Schellhammer als Naturwissenschaftler* is an admirable exposition), Dittes, and Bana. The compendium by the last-named author has passed through four editions in Germany, and has been translated into French, Flemish, and English. The English translation, *Elements of Psychology*, 1871, gives a lucid and succinct view of the whole system. (R. AD.)

BENEVENTO, a city of Italy, the capital of a province, situated on a hill near the confluence of the Calore and the Sabato, 32 miles N.E. of Naples. The town is surrounded by walls, and was formerly defended by a castle of the 12th century, which now contains Government offices and a prison. It occupies the site of the ancient *Beneventum*, and is largely built of its ruins. Except Rome, few cities can boast of so many remains of antiquity. Of these the most beautiful and perfect is the arch of Trajan, erected in 114 A.D., 53 feet in height, and consisting of a single arch of Parian marble of the Corinthian order, highly ornamented with basso and alto reliefs, which represent various events in the reign of that emperor. It now forms one of the gates of the city (*Porta Aurea*). Of the amphitheatre the remains, now known as *Grottoni di Mappa*, are in a very ruinous condition, and the arena is occupied by houses of a mean description. Benevento is the see of a bishop, and has a cathedral of the 12th century in the Lombardo-Saracenic style, in front of which is an Egyptian obelisk of granite covered with hieroglyphics. Among its other buildings may be mentioned the town-hall, the diocesan seminary, the lyceum, which was formerly a Jesuit college, and several hospitals. The principal manufactures are leather, parchment, and plated goods. A considerable trade is carried on in grain.

Beneventum, or, as it was originally called, Malocis or Maleventum, seems to have been of Samnite foundation. In 268 B.C. it was colonised by the Romans, who had probably been in possession of it for some time. During the second Punic war two of the most important battles were fought in the neighbourhood. It continued to be a very flourishing city till the close of the empire, and from its position on the *Fos Appia*, it often comes into notice. About 545 A.D. it was sacked by Totila, but before long had recovered its prosperity. Being raised to the rank of a duchy by Alboin, king of the Lombards, it continued in possession of its own dukes till 1053, when the emperor, Henry III., who had rendered himself master of the city, exchanged it with Leo IX. for the bishopric of Bamberg. From that time it continued in Papal possession till 1806, when the Emperor Napoleon I. bestowed it, with the title of prince, on Talleyrand.

## B E N G A L

**B**ENGAL (or, as it is often more precisely designated, "Lower Bengal"), the largest and most populous of the twelve local governments of British India, comprising the lower valleys and deltas of the Ganges and Brahmaputra, lies between 19° 18' and 26° 15' N. lat., and between 82° and 97° E. long. Excluding Assam, which was erected into a separate administration in February 1874, Bengal now includes the four great provinces of Bengal Proper, Behar, Orissa, and Chhotá or Ohutiá Nágpur; and forms a Lieutenant-Governorship with an area of 203,473 square miles, and a population of 64,444,379 souls. Including Assam, which, until the spring of 1874, was a part of Bengal, the area was 248,231 square miles, and the population 66,856,859. This great lieutenant-governorship, excluding Assam, contains one-third of the total population of British India, and yields a revenue of £17,687,072, or over one-third of the aggregate revenues of the Indian empire. It is bounded on the N. by Assam, Bhután, and Népal; on the S. by Burmah, the Bay of Bengal, and Madras; on the W. by an imaginary line running between it and the adjoining lieutenant-governorship of the North-Western Provinces, and by the plateau of the Central Provinces; and on the E. by the unexplored mountainous region which separates it from China and Northern Burmah. The territory, thus hemmed in, except at its north-western angle, by the unchangeable land-marks of nature, consists chiefly of two broad river valleys. By the western one, the Ganges brings down the wealth and the accumulated waters of Northern India. The eastern valley forms the route by which the Brahmaputra, after draining the Thibetan plateau far to the north of the Himalayas, and skirting round their passes not far from the Yangtee-Kiang and the great river of Cambodia, ends its boisterous journey of 1800 miles. These valleys, although for the most part luxuriant alluvial plains, are diversified by spurs and peaks thrown out from the great mountain systems which wall them in on the north-east and south-west. They teem with every product of nature, from the fierce beasts and irrepressible vegetation of the tropics, to the stunted barley which the hill-man rears, and the tiny furred animal which he hunts within sight of the unmelting snows. Tea, indigo, turmeric, lac, waving white fields of the opium-poppy, wheat and innumerable grains and pulses, pepper, ginger, betel-nut, quinine and many costly spices and drugs, oil-seeds of sorts, cotton, the silk mulberry, inexhaustible crops of jute and other fibres; timber, from the feathery bamboo and coronetted palm to the iron-hearted *al* tree—in short, every vegetable product which feeds and clothes a people, and enables it to trade with foreign nations, abounds. Nor is the country destitute of mineral wealth. The districts near the sea consist entirely of alluvial formations; and, indeed, it is stated that no substance so coarse as gravel occurs throughout the Delta, or in the heart of the provinces within 400 miles of the river mouths. But amid the hilly spurs and undulations on either side, coal, and iron and copper ores, hold out a new future to Bengal, as capital increases under the influence of a stable government, and our knowledge of the country becomes more exact. The coal-fields on the west have for exactly a century been worked by English enterprise; in 1868 they yielded 564,933 tons, and more in the two following years. In the east, the coal measures of Assam, which province was separated from Bengal in 1874, still await the opening out of the country and improved facilities of transport. The climate varies from the snowy regions of the Himalayas to the tropical vapour-bath of the Delta and the burning

winds of Behar. The ordinary range of the thermometer on the plains is from about 52° Fahr. in the coldest month to 103° in the shade in summer. Anything below 60° is considered very cold; and by care in the hot weather the temperature of well-built houses rarely exceeds 95°. The rainfall also varies greatly; from 500 to 600 inches per annum at Chará Púnji (Cherra Poonjee) on the range between Silhet and Assam, to an average of about 37 inches in Behar, and about 65 inches on the Delta.

**THE RIVERS.**—But the secret of Bengal is its rivers. These untaxed highways bring down, almost by the motive power of their own current, the crops of Northern India to the sea-board,—an annual harvest of wealth to the trading classes, for which the population of the Lower Provinces neither toil nor spin. Lower Bengal, indeed, exhibits the two typical stages in the life of a great river. In the northern districts the rivers, like our English ones, run along the valleys, receive the drainage from the country on either side, absorb broad tributaries, and rush forward with an ever increasing volume. But near the centre of the provinces the rivers enter upon a new stage of their career. Their main channels bifurcate, and each new stream so created throws off its own set of distributaries to right and left. The country which they thus enclose and intersect forms the Delta of Bengal. Originally conquered by the fluvial deposits from the sea, it now stretches out as a vast dead level, in which the rivers find their velocity checked, and their current no longer able to carry along the silt which they have brought down from Northern India. The streams, accordingly, deposit their alluvial burden in their channels and upon their banks, so that by degrees their beds rise above the level of the surrounding country. In this way the rivers in the Delta slowly build themselves up into canals, which every autumn break through or overflow their margins, and leave their silt upon the adjacent flats. Thousands of square miles in Lower Bengal annually receive a top-dressing of virgin soil, brought free of expense a quarter of a year's journey from the Himalayas,—a system of natural manuring which renders elaborate tillage a mere waste of labour, and which defies the utmost power of over-cropping to exhaust its fertility. As the rivers creep further down the Delta, they become more and more sluggish, and their bifurcations and interlacings more complicated. The last scene of all is a vast amphibious wilderness of swamp and forest, amid whose solitudes their network of channels insensibly merges into the sea. Here the perennial struggle between earth and ocean goes on, and all the ancient secrets of land-making stand disclosed. The rivers, finally checked by the dead weight of the sea, deposit their remaining silt, which emerges as banks or blunted promontories, or, after a year's battling with the tide, adds a few feet or, it may be, a few inches to the shore.

The Ganges, which enters on the western frontier, and runs diagonally across Bengal, gives to the country its peculiar character and aspect. About 200 miles from its mouth it spreads out into numerous branches, forming a large delta, composed, where it borders on the sea, of a labyrinth of creeks and rivers, running through the dense forests of the Sunderbans, and exhibiting during the annual inundation the appearance of an immense sea. At this time the rice fields to the extent of many hundreds of square miles are submerged. The scene presents to a European eye a panorama of singular novelty and interest;—rice fields covered with water to a great depth; the



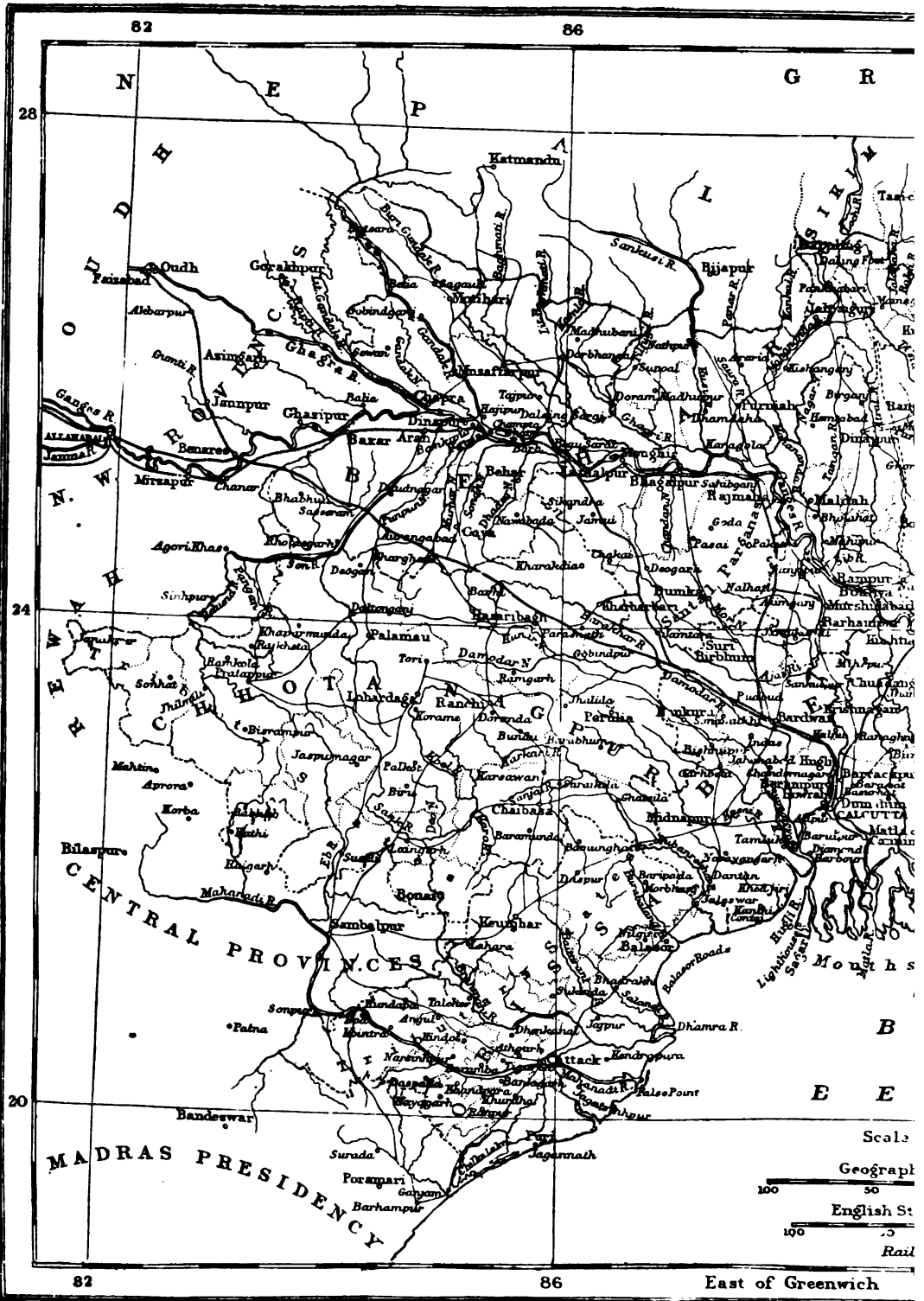







ears of grain floating on the surface; the stupendous embankments, which restrain, without altogether preventing, the excesses of the inundations; and peasants in all quarters going out to their daily work with their cattle in canoes or on rafts. The navigable streams which fall into the Ganges intersect the country in every direction, and afford great facilities for internal communication. In many parts boats can approach by means of lakes, rivulets, and water-courses, to the door of almost every cottage. The lower region of the Ganges is the richest and most productive portion of Bengal, abounding in valuable produce. Another mighty river by which Bengal is intersected is the Brahmaputra, the source of whose remotest tributary is on the opposite side of the same mountains which give rise to the Ganges. These two rivers proceed in diverging courses until they are more than 1200 miles asunder; and again approaching each other, intermix their waters before they reach the ocean. The other principal rivers in Bengal are the Ghagra, Son, Gandak, Kusi, Tistá; the Hugli (Hoogly), formed by the junction of the Bhágirathi and Jalangi; and farther to the west, the Damodar and Rápnáryan; and in the south-west, the Mahánadi, or great river of Orissa. In a level country like Bengal, where the soil is composed of yielding and loose materials, the courses of the rivers are continually shifting, from the wearing away of their different banks, or from the water being turned off by obstacles in its course into a different channel. As this channel is gradually widened the old bed of the river is left dry. The new channel into which the river flows is, of course, so much land lost, while the old bed constitutes an accession to the adjacent estates. Thus, one man's property is diminished, while that of another is enlarged or improved; and a distinct branch of jurisprudence has grown up, the particular province of which is the definition and regulation of the alluvial rights alike of private property and of the state.

**THE PEOPLE.**—Within the provinces under the Lieutenant-Governor of Bengal dwell a great congeries of peoples, of widely diverse origin, speaking different languages, and representing far separated eras of civilisation. They amounted in 1872 (including Assam, which then formed part of Bengal), to 66,856,859 souls, or over a million and a quarter more than the whole inhabitants of England and Wales, Sweden, Norway, Denmark (with Jutland), Greece, and all the Ionian Islands, with the total white population, Indians and Chinese, of the United States. The problem of government in Bengal, however, is not one of numbers. It is intensified and infinitely complicated by the fact, that while this vast population is ruled by a single head, it consists of elements so dissimilar as to render it impracticable to place them under any one system of administration. They exhibit every stage of human progress, and every type of human enlightenment and superstition,—from the sceptical educated classes, represented by the Hindu gentleman who distinguishes himself at a London Inn of Court and harangues the British public in the Brighton Pavilion, or from a metropolitan platform, to the hill chieftain, who lately sacrificed an idiot on the top of a mountain to obtain a favourable decision in a Privy Council appeal. A large section of the people belongs to the august Aryan race, from which we ourselves descend, having a classical language more kindred to our own than those of the Welsh or Scottish Highlanders. We address the Deity and His earthly representatives, our father and mother, by words derived from roots common to the Christian and the Hindu. Nor does the religious instinct assume a wider variety of manifestations, or exhibit a more striking series of metamorphoses, among the European than among the Indian branches of the race. Theodore Parker and Comte are

better known to the rising generation of Hindus in Bengal than any Sanskrit theologian. On the same bench of a Calcutta college sit youths trained up in the strictest theism, others indoctrinated in the mysteries of the Hindu trinity and pantheon, with representatives of every link in the chain of superstition—from the harmless offering of flowers before the family god to the cruel rites of Káli, whose altars in the most civilised districts of Bengal, as lately as the famine of 1866, were stained with human blood. Indeed, the very word Hindu is one of absolutely indeterminate meaning. The census officers employ it as a convenient generic to include 42½ millions of the population of Bengal, comprising elements of transparently distinct ethnical origin, and separated from each other by their language, customs, and religious rites. But Hinduism, understood even in this wide sense, represents only one of many creeds and races found within Bengal. The other great historical cultus, which, during the last two centuries, did for the Semitic peoples what Christianity accomplished among the European Aryans, has won to itself one-third of the whole population of Bengal. The Muhammadans exceed 20½ millions of souls; and the Lieutenant-Governor of Bengal is, so far as numbers go, as great a Mussalmán power as the Sultan of Turkey himself. Amid the stupendous catastrophes of the seasons, the river inundations, famines, tidal waves, and cyclones of the lower provinces of Bengal, the religious instinct works with a vitality unknown in European countries, where the forces of nature have long yielded to the control of man. Until the British Government stepped in with its police, and canals, and railroads, between the people and what they were accustomed to consider the dealings of Providence, scarcely a year passed without some terrible manifestation of the power and the wrath of God. Marhattá invasions from Centr. India, piratical devastations on the sea-board, banditti who marched about the interior in bodies of 50,000 men, floods which drowned the harvests of whole districts, and droughts in which a third of the population starved to death, kept alive a sense of human powerlessness in the presence of an Omnipotent fate with an intensity which the humiliations of a stipendiary clergy fail to awaken. Under the Muhammadans a pestilence turned the capital into a silent wilderness, never again to be re-peopled. Under our own rule, it is estimated that 10 millions perished within the Lower Provinces alone in the famine of 1769-70; and the first surveyor-general of Bengal entered on his maps a tract of many hundreds of square miles as bare of villages, and "depopulated by the Maghs."

**POPULAR RELIGIONS.**—The people of Bengal, thus constantly reminded by calamity of a mysterious Supreme Power, have always exhibited deep earnestness in their own modes of propitiating it, and a singular susceptibility to new forms of faith. Great tidal waves of religion have again and again swept over the provinces within even the brief period of the Christian era. Islám was one of many reformed creeds offered to them, and several circumstances combined to render its influence more widely spread and more permanent than that of its rivals. It was the creed of the governing power; its missionaries were men of zeal, who spoke to the popular heart; it brought the good news of the unity of God and the equality of man to a priest-ridden and a caste-ridden people. Above all, the initiatory rite made relapse impossible, and rendered the convert and his posterity true believers for ever. Forcible conversions are occasionally recorded, with several well-known instances of Hindus becoming apostates from their ancient faith to purchase pardon for crimes. Such cases, however, were few in number, and belonged to the higher ranks. It would also appear that a Mughul adventurer now and then

circumcised off hand the villages allotted to him in fief. But it was not to such measures that Islām owed its permanent success in Bengal. It appealed to the people, and it derived the great mass of its converts from among the poor. It brought in a truer conception of God, a nobler ideal of the life of man, and offered to the teeming low castes of Bengal, who had sat for ages despised and abject on the outermost pale of the Hindu community, free entrance into a new social organisation. So far as local tradition and the other fragmentary evidence which survives enable a modern inquirer to judge, the creed of Muhammad was here spread neither by violence nor by any ignoble means. It succeeded because it deserved to succeed. Nevertheless, it has conspicuously failed to alter the permanent religious conceptions of the people. The initiatory rite separated the Musalmāns from the rest of the Bengali population, and elevated the heterogeneous low-caste converts into a respectable community of their own. But the proselytes brought their old superstitions with them into their new faith. Their ancient rites and modes of religious thought reasserted themselves with an intensity that could not be suppressed, until the fierce white light of Semitic monotheism almost flickered out amid the fuliginous exhalations of Hinduism. A local writer, speaking from personal acquaintance with the Musalmān peasantry in the northern districts of Lower Bengal, states that not one in ten can recite the brief and simple *kālm* or creed, whose constant repetition is a matter of almost unconscious habit with Muhammadans. He describes them as "a sect which observes none of the ceremonies of its faith, which is ignorant of the simplest formulas of its creed, which worships at the shrines of a rival religion, and tenaciously adheres to practices which were denounced as the foulest abominations by its founder." Fifty years ago these sentences would have truly described the Muhammadan peasantry, not only in the northern districts, but throughout all Lower Bengal. In the cities, or amid the serene palace life of the Musalmān nobility and their religious foundations, a few Maulvis of piety and learning calmly carried on the routine of their faith. But the masses of the rural Musalmāns had relapsed into something little better than a mongrel breed of circumcised low-caste Hindus. Since then, one of those religious awakenings so characteristic of India has passed over the Muhammadans of Bengal. Itinerant preachers, generally from the north, have wandered from district to district, calling on the people to return to the true faith, and denouncing God's wrath on the indifferent and unrepentant. A great body of the Bengali Musalmāns have purged themselves of the taint of Hinduism, and shaken off the yoke of ancient rural rites. The revival has had a threefold effect—religious, social, and political. It has stimulated the religious instinct among an impressionable people, and produced an earnest desire to cleanse the worship of God and His prophet from idolatry. This stern rejection of ancient superstitions has widened the gulf between the Muhammadans and the Hindus. Fifty years ago the Bengali Musalmāns were simply a recognised caste, less widely separated from the lower orders of the Hindus than the latter were from the Kulin Brāhmins. There were certain essential points of difference, of a doctrinal sort, between the Hindu and Muhammadan villager; but they had a great many rural customs and even religious rites in common. The Muhammadan husbandman theoretically recognised the one Semitic God; but in a country subject to floods, famines, the devastations of banditti, and the ravages of wild beasts, he would have deemed it a simple policy to have neglected the Hindu festivals in honour of Krishna and Durgā. The Bengali peasantry no longer look to their gods, but to the officer in charge of the district, for protection; and when he fails

them, instead of offering expiatory sacrifices to Kālī, they petition Government, or write violent letters to the vernacular press. The reformed Muhammadan husbandmen now stand aloof from the village rites of the Hindus. They have ceased to be merely a separate caste in the rural organisation, and have become a distinct community, keeping as much apart from their nominal co-religionists of the old unreformed faith as from the idolatrous Hindus. This social isolation from the surrounding Hindus is the second effect of the Musalmān revival in Bengal. Its third result is political, and affects ourselves. A Muhammadan like a Christian revival strongly reasserts the duty of self-abnegation; and places a multitude of devoted instruments at the disposal of any man who can convince them that his schemes are identical with the will of God. But while a return to the primitive teachings of Christ means a return to a religion of humanity and love, a return to Muhammadan first principles means a return to a religion of intolerance and aggression. The very essence of Musalmān Puritanism is abhorrence of the Infidel. The whole conception of Islām is that of a church either actively militant or conclusively triumphant—forcibly converting the world, or ruling with a rod of iron the stiff-necked unbeliever. The actual state of India, where it is the Musalmāns who are in subjection, and the unbeliever who governs them, is manifestly not in accord with the primitive ideal; and many devout Muhammadans of the reformed faith have of late years endeavoured, by plots and frontier attacks, to remove this anomaly. The majority are not actively hostile, but they stand aloof from our institutions, and refuse to coalesce with the system which the British Government has imposed on Bengal. Their rebel camp beyond our frontier has forced us into three expeditions, which has broken their military power; and the calm, inexorable action of the courts has stamped out the chronic abatement of rebellion by Muhammadans within Bengal.

Besides the 42½ millions aggregated under the name of Hindus, and the 20½ millions of Musalmāns, a great residue remains. These consist, with the exception of two very small bodies of Christians and Buddhists, of semi-aboriginal and distinctly non-Aryan races. They number over ½ millions, equalling almost exactly the population of Scotland. These peoples dwell, for the most part, among the lofty ranges and primeval forests which wall in Bengal on the north, east, and south-west, or upon the spurs and hilly outworks which these mountain systems have thrown forward upon the lowlands. Some of them represent the simplest types of social organisation known to modern research. Their rudimentary communities are separated by religion, custom, and language from each other and from the dwellers on the plains. Many of them, till lately, looked upon war as the normal condition of human society, and on peace as an unwelcome temporary break in their existence. For ages they have regarded the lowland Hindus as their natural enemies, and in turn have been dealt with as beasts of chase by the more civilised inhabitants of the valleys. Within the present generation human sacrifice continued to be an obligatory rite among them—a rite so deeply graven upon their village institutions, and so essential to the annually recurring festivals of their religious year, as to seriously occupy the Indian legislature, and to require a special agency to suppress it. To this day instances of the detestable practice occur; and their extreme jealousy of anything like foreign rule renders it the wisest policy to leave them as much as possible under their own hamlet communities and petty chiefs. Nevertheless, they form the most hopeful material yet discovered in Bengal for the humanising influences of Christianity, and of that higher level of

morality and religious hope which Christian missions represent.

**GOVERNMENT.**—Nor are the diversities in race and religion among the 66½ millions of Bengal less marked than their different capacities for self-government, and the varying degrees to which they can be subjected to administrative control. They exhibit every stage of political development, from the great municipality based upon English models, with powers of self-taxation and a public debt of its own, down to the primitive hill-hamlet, which pays no rent, acknowledges no higher tenure than the aboriginal one of priority of occupation, clings to its ancient system of nomadic husbandry, and is scarcely aware of any power superior to that of its own tribe fathers. Including Assam, which up to February 1874 formed a part of Bengal, the territories under the Lieutenant-Governor consist of five great provinces, each of which speaks a language of its own, and has a separate political and ethnical history. For administrative purposes these five provinces are divided into 58 districts, of which 36 are regulation districts, whose advanced state has rendered it expedient to place them under the complete system of Anglo-Indian law; while 22 are non-regulation districts, in which this has not yet been found practicable. The latter contain territories of three distinct classes. The first of them consists, for the most part, of newly-acquired territory, to which the general regulations have never been extended in their entirety. The second, of tracts inhabited by primitive races specially exempted from the operation of the regulations, to whom a less formal code of law is better adapted. The third, of semi-independent or tributary states, administered, or partly administered by British officers. The management of the whole is firmly concentrated in a single man, the Lieutenant-Governor of Bengal, who is answerable to the Government of India, and through it to Her Majesty's ministers and Parliament. His responsibility is divided by no executive council, as in Madras or Bombay. All orders issue through his secretaries in his own name; and although his policy is subject to the watchful control of the Government of India, represented by the Viceroy, yet to the Lieutenant-Governor personally belongs the reputation or disgrace of a successful or an inglorious administration. In making laws for his people he is assisted by a legislative council, composed partly of his principal officers, partly of leading members of the non-official European and Native communities. In his legislative, as in his executive functions, a power of control, amounting if needful to veto, rests with the Government of India—a power which, from the English talent for harmonious proconsular rule, is very seldom exercised. The administration is conducted by a body of covenanted civilians, supplemented by a few military officers in the less civilised districts, and aided by a staff of subordinate officials. The civilians are appointed direct from England, enter into a bond with the Secretary of State, and give securities for the discharge of their highly responsible duties. In 1871 they numbered 260 men. The military officers belong to the staff corps of the Bengal army, and are employed to the number of 52 in the backward tracts, which do not require so exact an administration, and cannot afford to pay for the cost of it. The subordinate district officials are appointed in Bengal by the Lieutenant-Governor, and consist chiefly of natives and Anglo-Indians; but several departments, such as the educational, telegraph, and public works, are now officered to a certain extent by gentlemen engaged direct from England. The revenues raised in the territories under the Lieutenant-Governor of Bengal amounted in 1871-72 to £17,687,072. Of this sum, £16,713,636 accrued from the imperial taxes laid on by the Government of India, and £973,436, from provincial, municipal, and rural tax-

tion. The total cost of government was only £6,338,968, leaving a surplus from this single one of the Indian local governments of £11,348,104. It is scarcely too much to say, that so long as the British power retains the port of Calcutta and the rich provinces under the Lieutenant-Governor of Bengal, it would have sufficient revenue to effect the reconquest of India if any accident should happen in the Panjáb or north-west. The vast income which the Lower Provinces yield is not altogether derived from their people. China pays an annual tribute of over 5 millions in the shape of opium duty, and the inland parts of India contribute about a third of a million to the customs of Bengal. Taking the total thus obtained from other territories at a little over 6 millions, the population under the Lieutenant-Governor of Bengal pays, in round figures, 11½ millions a year, or about 3s. 5d. a head. This includes imperial, provincial, municipal, and rural taxation of every sort.

The return which the Government gives for this light taxation may be briefly summed up as follows:—It assures to the provinces absolute protection from foreign enemies. The army employed in the territories under the Lieutenant-Governor of Bengal numbers only 11,554 officers and men, exclusive of a detachment of Madras Native infantry stationed at Cattaek, in Orissa, and numbering about 600 men—making a gross total of troops in Bengal of about 12,000 men. Of this small force 4662 are massed in Calcutta and its environs, with a view to their proximity to the sea-board, rather than with an eye to the internal requirements of the country; 6892 guard the frontiers, with detachments on the line of railway, which now forms the great highway of Bengal; a detachment of about 600 effective troops of the Madras Native infantry is stationed in Orissa. Taking 12,000 as the total military force stationed in Bengal, 3000 consist of European troops and English-officers, and 9000 of Native officers and men. The Government is a purely civil one, the existence of any armed force being less realised than in the quietest county of England; and of the 66½ millions of people under the Lieutenant-Governor of Bengal, probably 40 millions go through life without once seeing the gleam of a bayonet or the face of a soldier. Internal order and protection to person and property are secured by a large army of police. This force consists of two elements: a regular constabulary introduced by the English Government, numbering 33,913 men in 1871, and costing £584,059 to the state; and an indigenous police developed out of the rural watch of the ancient Hindu commonwealth, numbering 184,645 men, and costing £435,336 a year, paid by grants of land, or by the villages and landowners. The total number of the Bengal police amounts therefore to 217,558, or one man to every 307 of the population; and, excluding uninhabited swamps and hill jungles, about one policeman to each square mile of area. This minute supervision costs just over a million sterling a year, being at the rate of £4, 2s. 1½d. per square mile, or 3½d. per head of the population.

A great system of state education has been rapidly developed since 1854. In 1871-72 the Government and aided schools numbered 4383, with 7292 teachers, and 163,280 pupils,—maintained at a total cost of £194,716, of which Government contributed rather under one-half, or £89,649. The total annual cost of education per pupil was £1, 12s. 9d., of which Government bore under one-half, or 15s.; the remainder being obtained from school fees, local subscriptions, &c. Besides these, there were 10,907 ascertained schools not receiving aid from the state, with 11,026 teachers, and 169,917 pupils. In addition to these, there is a vast number of petty hedge schools in Bengal, of which no statistics exist. The total of state and ascertained

private schools in 1871, was 15,390, with 18,316 teachers, and 333,197 pupils.

The cheapness of labour, as compared with European countries, enables the Government to perform its other functions at an equally small cost. It has brought courts very near to the door of the peasant, and established a system of registration by which proprietary rights and transfers are cheaply and absolutely ascertained. A great department of public works has spread a network of roads over the country, connecting Bengal by railways with other parts of India, and, in districts which specially require it, is endeavouring to exercise some degree of control over the rivers and the natural water-supply, on which the safety of a tropical people depends. An organised system of emigration watches over the movements of the landless classes, from the overcrowded or unfertile districts of the west to the rich under-populated territories on the east,

and to colonies beyond the sea. Charitable dispensaries and a well-equipped medical department struggle to combat the diseases and epidemics which from time immemorial have devastated the Delta, and place the operations of European surgery within the reach of the poorest peasant. The whole cost of civil administration for the 66½ millions of Bengal amounts, as already stated, to £6,338,968, or under 1s. 11d. per head. An untutored vernacular press makes known the views of the people to their rulers, and municipal institutions are developing the ancient Hindu capacity for self-government from the village to the municipal stage of human society.

**LOCAL DIVISIONS.**—The following table exhibits the four provinces at present under the Lieutenant-Governor of Bengal, along with Assam, which until February 1874 was within it.

*Area, Population, and Languages of the Five Provinces of Lower Bengal (including Assam) in 1872.*

Province.	Area in square miles.	Population.	Average population per sq. mla.	Percentage of entire area.	Percentage of the whole population.	Languages.
Bengal, .....	94,539	36,769,785	389	38·08	55·00	Bengali and Hindustani.
Behar, .....	42,417	19,786,101	465	17·09	29·52	Hindustani and Hindi.
Orissa (including the Tributary States),	22,901	4,817,999	181	9·63	6·48	Uriya, and aboriginal tongues and patia.
Chota Nâgpur, .....	48,901	3,825,571	87	17·69	5·72	Bengali and aboriginal tongues.
Assam (separated in 1874), .....	43,473	2,207,453	51	17·51	3·30	Assamese, Bengali, and aboriginal tongues.
Total, .....	248,231	66,856,859	269	100·00	100·00	

The word **BENGAL** is derived from Sanskrit geography, and applies strictly to the country stretching southwards from Bhâgalpur to the sea. The ancient Banga formed one of the five outlying kingdoms of Aryan India, and was practically continuous with the Delta of Bengal. It derived its name, according to the etymology of the Pandita, from a prince of the Mahâbhârata, to whose portion it fell on the primitive partition of the country among the Lunar race of Delhi. But a city called Bângalâ, near Chittagong, which, although now washed away, is supposed to have existed in the Muhammadan period, appears to have given the name to the European world. The word Bângalâ was first used by the Musalmâns; and under their rule, like the Banga of old Sanskrit times, it applied specifically to the Gangetic delta, although the latter conquests to the east of the Brahmaputra were eventually included within it. In their distribution of the country for fiscal purposes, it formed the central province of a governorship, with Behar on the N.W., and Orissa on the S.W., jointly ruled by one deputy of the Delhi emperor. Under the English the name has at different periods borne very different significations. Francis Fernandez applies it to the country from the extreme east of Chittagong to Point Palmyras in Orissa, with a coast line which Purchas estimates at 600 miles, running inland for the same distance, and watered by the Ganges. This territory would include the Muhammadan province of Bengal, with parts of Behar and Orissa. The loose idea thus derived from old voyagers became stereotyped in the archives of the East India Company. All its north-eastern factories, from Balasor, on the Orissa coast, to Patnâ, in the heart of Behar, belonged to the "Bengal Establishment," and as our conquests crept higher up the rivers, the term came to be applied to the whole of Northern India. The Presidency of Bengal, in contradistinction to those of Madras and Bombay, eventually included all the British territories north of the Central Provinces, from the mouths of the Ganges and Brahmaputra to the Himalayas and the Panjâb. The term Bengal continues to be officially employed in this sense by the military

department of the Government of India. But during the last forty years the tendency to a more exact order of civil administration has gradually brought about a corresponding precision in the use of Indian geographical names. The North-Western Provinces date their separate existence from 1831. Since that year they stand forward under a name of their own as the North-Western Provinces, in contradistinction to the Lower Provinces of Bengal. Later annexations have added new territorial entities, and the northern Presidency is now mapped out into four separate governments—the North-Western Provinces, Oudh, Panjâb, and Lower Bengal. Three of the provinces of the present Lieutenant-Governorship of Bengal—namely, Bengal proper, Behar, and Orissa—consist of great river valleys; the fourth, Chhotâ or Chutiâ Nâgpur, is a mountainous region which separates them from the Central India plateau. Orissa embraces the rich deltas of the Mahânâdi and the neighbouring rivers, bounded by the Bay of Bengal on the S.E. and walled in on the N.W. by tributary hill states. Proceeding westward, the province of Bengal proper stretches along the coast from Orissa to British Burmah, and inland from the sea-board to the Himalayas. Its southern portion is formed by the united deltas of the Ganges and Brahmaputra; its northern consists of the valleys of these great rivers and their tributaries. Behar lies on the north-west of Bengal proper, and comprises the higher valley of the Ganges, from the spot where it issues from the territories of the Lieutenant-Governor of the North-Western Provinces. Between Behar and Orissa, but stretching further westward and deep into the hill country, lies the province of Chhotâ or Chutiâ Nâgpur.

**ADMINISTRATIVE DIVISIONS.**—For administrative purposes, the Lieutenant-Governorship of Bengal, excluding the recently separated province of ASSAM (see under that heading), is divided into 47 districts. The details of the area and population of these, presented in the following table, are taken, with few exceptions, from the census returns of 1872 :—

District.	Area—square miles.	Population.	Hindus.	Muhammadans.	Christians.	Others.	Population per square mile.	Land Revenue.
<b>BENGAL PROPER.</b>								
1. Bardwan, .....	3,523	2,084,745	1,079,363	848,024	890	6,468	578	£306,454
2. Bankura, .....	1,346	526,772	487,786	13,500	70	25,416	391	45,065
3. Birbhum, .....	1,344	695,921	576,908	111,795	249	6,969	518	73,223
4. Midnapur, .....	5,082	2,540,968	2,285,568	157,047	613	97,735	500	203,400
5. Hooghly with Howrah, .....	1,424	1,488,556	1,186,485	299,025	2,583	513	1,045	144,848
6. 24 Parganas, .....	2,788	2,210,047	1,307,087	887,858	13,767	1,840	798	2,440
7. Calcutta, .....	8	447,601	291,194	153,131	21,356	1,920	55,950	170,287
8. Nadia, .....	3,421	1,812,795	821,032	984,106	5,977	1,680	530	105,080
9. Jessor, .....	3,058	2,076,021	915,413	1,151,936	1,142	6,530	567	103,184
10. Murshidabad, .....	2,578	1,353,626	733,056	603,564	537	16,469	525	135,883
11. Dinajpur, .....	4,126	1,501,924	702,235	793,215	270	6,203	364	175,566
12. Malda, .....	1,813	676,426	356,298	310,890	43	9,195	373	32,414
13. Rajshahi, .....	2,534	1,810,729	286,870	1,017,979	103	5,777	587	102,681
14. Rangpur, .....	3,476	2,149,972	857,298	1,291,465	73	1,136	619	96,662
15. Bogra, .....	1,601	689,467	130,644	556,620	22	2,181	459	44,160
16. Pabna, .....	1,966	1,211,594	361,314	847,227	98	2,955	616	24,066
17. Dargiling, .....	1,234	94,712	69,831	6,248	566	18,077	77	6,376
18. Jalpaiguri, <sup>1</sup> .....	2,906	418,665	182,375	144,980	36	504	144	26,547
19. Kuch Behar, <sup>2</sup> .....	1,307	582,565	793,789	Details not available.			407	...
20. Dacca, .....	2,897	1,852,993	430,983	1,050,131	7,844	1,229	640	48,996
21. Faridpur, .....	1,496	1,012,589	827,393	588,299	463	2,359	677	32,764
22. Bakarganj, .....	4,935	2,377,433	817,963	1,540,965	4,862	4,232	482	151,128
23. Maimansingh, .....	6,293	2,349,917	859,284	1,519,635	124	12,195	373	84,965
24. Silhet, .....	5,383	1,719,689	301,138	854,131	159	6,015	319	48,311
25. Chittagong, .....	2,498	1,127,402	180,253	795,013	1,084	30,169	451	76,089
26. Noakhali, .....	1,657	713,984	540,156	533,053	552	76	459	56,161
27. Tipperah, .....	2,552	1,533,931	593,564	993,564	146	65	578	100,322
28. Chittagong Hill Tracts, Hill Tipperah State, .....	6,582	69,607	593	1,378	81	67,600	10	...
	3,567	85,262		Details not available.			9	...
<b>Total, .....</b>	<b>84,198</b>	<b>36,564,708</b>	<b>17,972,219</b>	<b>17,584,774</b>	<b>63,641</b>	<b>235,567</b>	<b>428</b>	<b>£2,418,002</b>
<b>BEHAR.</b>								
29. Patna, .....	2,101	1,559,688	1,863,291	192,988	2,700	659	742	£145,050
30. Gaya, .....	4,718	1,949,750	1,729,899	219,332	203	316	413	136,261
31. Shahabad, .....	4,585	1,723,974	1,590,643	132,671	461	199	398	174,591
32. Tirhut, .....	6,348	4,384,706	3,854,991	523,605	716	394	691	176,702
33. Saran, .....	2,654	2,063,860	1,822,048	241,590	207	16	778	211,936
34. Champaran, .....	3,531	1,440,315	1,240,264	199,237	1,307	7	408	51,578
35. Monghir, .....	3,913	3,312,986	1,613,546	152,269	1,142	16,029	463	81,015
36. Bhagalpur, .....	4,237	1,826,290	1,639,949	169,426	532	14,833	422	67,925
37. Purniah, .....	4,967	1,714,795	1,022,009	690,149	493	2,334	346	127,093
38. Santal Parganas, .....	5,483	1,259,287	650,210	79,786	303	523,899	229	12,154
<b>Total, .....</b>	<b>42,417</b>	<b>19,786,101</b>	<b>16,526,850</b>	<b>2,636,053</b>	<b>3,063</b>	<b>565,135</b>	<b>465</b>	<b>£1,184,905</b>
<b>ORISSA.</b>								
39. Cuttack, .....	3,173	1,494,784	1,430,040	40,013	2,314	22,417	470	233,416
40. Puri, .....	2,475	769,674	739,636	11,584	576	17,676	311	45,862
41. Balasor, .....	3,066	770,232	735,396	18,873	530	12,423	373	40,424
42. Tributary States, .....	16,184	1,233,309	879,658	3,995	303	392,356	79	...
<b>Total, .....</b>	<b>23,901</b>	<b>4,317,999</b>	<b>3,787,727</b>	<b>74,472</b>	<b>3,723</b>	<b>422,077</b>	<b>180</b>	<b>£169,702</b>
<b>CHHOTÁ NÁGPUR.</b>								
43. Hazaribagh, .....	7,021	771,375	647,991	73,388	1,573	49,973	110	£7,041
44. Lohardaga, .....	12,044	1,237,123	741,952	58,211	12,781	424,179	103	9,732
45. Singhbhum, .....	4,503	415,023	309,632	2,487	852	202,052	92	5,934
46. Manbhum, .....	4,914	995,570	827,936	33,622	592	133,420	203	6,562
47. Tributary States, .....	15,419	405,980	139,781	2,348	...	263,851	26	...
<b>Total, .....</b>	<b>43,901</b>	<b>3,325,571</b>	<b>2,567,292</b>	<b>169,006</b>	<b>15,798</b>	<b>1,073,475</b>	<b>87</b>	<b>£29,279</b>
<b>Grand Total, .....</b>	<b>194,417*</b>	<b>64,444,379</b>	<b>40,354,088</b>	<b>20,414,305</b>	<b>91,225</b>	<b>2,426,254</b>	<b>331</b>	<b>£2,796,888</b>

<sup>1</sup> The census of the Duars of Jalpaiguri was taken in 1869-70, at the time of the land settlement, and the details of the population, according to religion, were not ascertained for this part of the district. The details, therefore, do not agree with the total population.

<sup>2</sup> Census taken at the time of settlement. Details not ascertained.

\* This area is exclusive of 5341 square miles of unsurveyed Sundarbans, and one or two minor tracts; total area of all Bengal, 203,473 square miles.

**PRINCIPAL CROPS.**—The chief products of the province have been already enumerated. The great staple crop is rice, of which there are three harvests in the year,—the *boro*, or spring rice; *aus*, or autumn rice; and *aman*, or winter rice. Of these the last or winter rice is by far the most extensively cultivated, and forms the great harvest of the year. The *aman* crop is grown on low land. In May, after the first fall of rain, a nursery ground is ploughed three times, and the seed scattered broadcast. When the seedlings make their appearance another field is prepared for transplanting. By this time the rainy season has thoroughly set in, and the field is dammed up so as to retain the water. It is then repeatedly ploughed until the water becomes worked into the soil, and the whole reduced to thick mud. The young rice is then taken from the nursery, and transplanted in rows about 9 inches apart. If, by reason of the backwardness of the season, the nursery ground cannot be prepared by the sowing-time in April or May, the *aman* rice is not transplanted at all. In such a case the husbandmen in July or August soak the paddy in water for one day to germinate, and plant the germinated seed not in a nursery plot, but in the larger fields, which they would otherwise have used to transplant the sprouts into. It is very seldom, however, that this procedure is found necessary. *Aman* rice is much more extensively cultivated than *aus*, and in favourable years is the most valuable crop, but being sown in low lands is liable to be destroyed by excessive rainfall. Harvest takes place in December or January. *Aus* rice is generally sown on high ground. The field is ploughed when the early rains set in, ten or twelve times over, till the soil is reduced nearly to dust, the seed being sown broadcast in April or May. As soon as the young plants reach 6 inches in height, the land is harrowed for the purpose of thinning the crop and to clear it of weeds. The crop is harvested in August or September. *Boro*, or spring rice, is cultivated on low marshy land, being sown in a nursery in October, transplanted a month later, and harvested in March and April. An indigenous description of rice, called *wri* or *jaradhna*, grows in certain marshy tracts. The grain is very small, and is gathered for consumption only by the poorest. No tabulated statistics of cultivation exist; but in 1872-73 the quantity of rice exported from Bengal to foreign ports amounted to 288,955 tons, of the value of £1,685,170. Oil-seeds are very largely grown over the whole of Bengal, particularly in the Behar and Assam districts. The principal oil-seeds are *sarisha* (mustard), *til* (sesamum), and *tisi*, or *masina* (linseed). Exports of oil-seeds are principally confined to linseed, of which 107,723 tons were exported in 1872-73, of the value of £1,077,348. Jute (*pat* or *kota*) now forms a very important commercial staple of Bengal. The cultivation of this crop has rapidly increased of late years. Its principal seat of cultivation is Eastern Bengal, where the superior varieties are grown. The crop grows on either high or low lands, is sown in April, and cut in August. In 1872 the area under jute cultivation in Bengal was estimated at 925,899 acres, and the yield at 496,703 tons. Jute exports from Bengal amounted in 1872-73 to 353,097 tons, value £4,127,943. Jute manufactures, in the shape of gunny bags, cloth, rope, &c., were also exported to the value of £187,149. Indigo cultivation and manufacture is principally carried on with European capital. In Bengal proper the industry has languished of late years, and the area under indigo cultivation greatly fallen off. In Behar, on the other hand, the area of indigo lands has increased. The annual out-turn for all Bengal is estimated at about 75,000 maunds, valued at nearly two millions sterling. Two crops of indigo are raised in the year: one sown in April or May before the setting in of the rains, and cut in August or September; the other sown in October as the waters

subside, and cut in the following July. The crop of 1872 was considerably above the average, the total exports amounting to 5962 tons, of the value of £2,704,090. Tea cultivation is the other great industry carried on by European capital. The cultivation is principally confined to Assam, which province was recently separated from the Lieutenant-Governorship, and to the northern Bengal district of Dárjiling. In the other localities in which tea is grown, Ohhotá Nággpur and Chittagong, cultivation is at present only carried on on a small scale. Tea cultivation has enormously extended of late years, and the gardens are, as a general rule, well filled with plants, highly cultivated and carefully managed. Including Assam, the total area held under the Waste Land Rules by persons connected with the tea industry, amounted in 1872 to 804,582 acres. Of this area 70,341 acres are returned as actually cultivated with tea, but this is probably too low an estimate. The exports of tea in 1872-73 amounted to 17,641,070 lb., valued at £1,567,561. Besides what is exported, there is an increasing local consumption of Indian tea. In 1860 the total out-turn of tea did not exceed one million lb. The cultivation of opium is a Government monopoly; no person is allowed to grow the poppy except on account of the Government. The manufacture is carried on at two separate agencies,—that of Benares in the North-Western Provinces, of which the head station is at Ghásipur; and that of Behar, with its head station at Patná. Annual engagements are entered into by the cultivators, under a system of pecuniary advances, to sow a certain quantity of land with poppy, and the whole produce in the form of opium is delivered to Government at a fixed rate. The area under poppy cultivation in the Behar agency, situated entirely within Bengal, in 1872, amounted to 330,925 acres; in the Benares agency to 229,450 acres, total, 560,355 acres. The number of chests of opium sold at the Government sales in Calcutta in 1872, was 42,675, the amount realized was £8,067,701, and the net revenue, £4,259,376. The cultivation of the cinchona plant in Bengal was introduced as an experiment about 1862, in a valley of the Himalayas in Dárjiling district, and the enterprise has already attained a point which promises success. There are now (1874) about 2000 acres of Government cinchona plantations in Dárjiling.

**MINERAL PRODUCTS.**—A brief statement has already been given of the principal minerals of Bengal. The coal mines of Rániganj, within Bardwán district, however, demand somewhat more special notice. In this field there were, in 1872, altogether 44 mines worked, of which 19 turn out more than 10,000 tons of coal per annum apiece. In the larger and better mines, coal is raised by steam power from pits and galleries; and in the smaller mines or workings, by hand labour from open quarries. In the Rániganj coal-field alone, 61 steam engines, with an aggregate of 867 horse-power, are at work. Only one seam or set of seams of less thickness than 8½ feet is worked, and the average thickness of the seams at the Rániganj mines is about 15 or 16 feet. The pits are mostly shallow, very few are more than 150 feet deep. The Bengal Coal Company, with its mines at Rániganj and westwards, is able to raise from them 220,000 tons of coal annually. Salt manufacture was formerly a Government monopoly, principally carried on along the sea-coast of Orissa and in Midnapur district. An account of the manufacture of salt by means of evaporation by fire is given in the account of BALASOR (q.v.) The process of manufacture by means of solar evaporation will be described in the account of Puri district. Government abandoned its monopoly of salt manufacture many years ago, and it is now carried on by private parties on their own account, subject to a Government duty in Bengal of 8s. 8d. a cwt. levied at the place of production. Salt duties



vary in different parts of India, necessitating the maintenance of expensive and cumbrous customs lines. This year (1874) an attempt has been made towards the abolition of the Orissa customs line, by means of a graduated scale of salt duty within Orissa, rising by degrees from the Madras duty of 4s. 10d. a cwt. in the extreme south of the province, to the Bengal duty of 8s. 8d. a cwt. in the extreme north. At the present day the greater quantity of salt consumed in Bengal is imported by Liverpool ships from the Cheshire mines. In 1872 the Bengal salt duty yielded a net revenue of £2,610,286.

**TRADE.**—No complete statistics of the internal trade of Bengal exist. The Ganges, the Brahmaputra, and on a much smaller scale, the Mahánadi in Orissa, with the Eastern Bengal Railway and the great East Indian Line, form the main arteries of commerce. From these main channels a network of minor streams, and a fairly adequate although not yet complete system of raised roads, radiate to the remotest districts. The chief articles of internal traffic are the vegetable and mineral productions enumerated above. The larger transactions of commerce are conducted in the great cities, such as Calcutta and Patna, and in a number of purely market centres, such as Nawábganj and Sirájganj, which have recently grown up under British rule. The smaller operations of trade are effected by means of village markets and countless *hats* or open air weekly bazárs in every district. The external trade of Bengal is practically confined to Calcutta. There are about ten other ports on the Bay of Bengal, the most important of which is the rice port of Chittagong. But for general purposes the foreign and interportal commerce of Calcutta may be taken to represent that of the province. In 1871–72 it stood thus: exports from Calcutta, £32,771,152; imports, £21,365,677; total, £54,136,829. The chief articles of export are rice, opium, indigo, jute, tea, oil-seeds, silk, cotton, and fibres. Chief imports, Manchester goods, woollens, salt, coal, iron, metals, liquors, and oilmen's stores.

**HISTORY.**—The history of so large a province as Bengal forms an integral part of the general history of India. (See INDIA.) The northern part, Behar, formed a powerful kingdom in Sanskrit times, and its chief town, Patná, is identified as the *Pálíbothra* of the Greeks. The Delta or southern part of Bengal lay beyond the ancient Sanskrit polity, and was governed by a number of local kings belonging to a pre-Aryan stock. The Chinese travellers, Fa Hsiang in the 6th century, and Hiouen Tsiang in the 7th century, found the Buddhist religion prevailing throughout Bengal, but already in a fierce struggle with Hinduísm—a struggle which ended about the 9th or 10th century in the general establishment of the latter faith. Until the end of the 12th century Hindu princes governed in a number of petty principalities, till, in 1199, Muhammad Bakhtiyar Khilji was appointed to lead the first Musalmán invasion into Bengal. The Muhammadan conquest of Behar dates from 1200 A.D., and the new power speedily spread southwards into the Delta. From about this date until 1340 Bengal was ruled by governors appointed by the Muhammadan emperors in the north. From 1340 to 1539 its governors asserted a precarious independence, and arrogated the position of sovereigns on their own account. From 1540 to 1576 Bengal passed under the rule of the Pathán or Afghán dynasty, which commonly bears the name of Sher Sháh. On the overthrow of this house by the powerful arms of Akbar, Bengal was incorporated into the Mughal empire, and administered by governors appointed by the Delhi emperor, until the treaties of 1765, which placed Bengal, Behar, and Orissa under the administration of the East India Company. Until 1854 Bengal remained under the Governor-General of India as governor, his place being supplied, during his absence in other parts of India,

by a deputy-governor from among the members of his council. By the statute 16 and 17 Vict. cap. 95, these two great offices were separated, and Bengal erected into a Lieutenant-Governorship. The first lieutenant-governor was appointed in 1854, and the constitution of the Government of Bengal still continues on this basis, except that the lieutenant-governor is now appointed subject to the approval of Her Majesty. In a brief sketch like the present it is impossible to attempt further historical details beyond a bare list of the successive rulers, and the dates of their accession.

FIRST PERIOD.

*Early Muhammadan Conquerors of Bengal.*

A.D.	A.H.	Governors of Bengal.	Emperors of Hindustan.	Kings of England.
1204	600	Bakhtiyar Khilji	Kutab	John
1206	602	Muhammad Sherán	Do.	Do.
1208	605	Alí Mardán	Do.	Do.
1212	609	Ghyyas Uddín	Altamah	Do.
1227	624	Nasir Uddín	Do.	Henry III.
1230	627	Alá Uddín	Do.	Do.
1237	634	Tughan Khán	Sultán Riziá	Do.
1244	642	Taimur Khán	Bahram II.	Do.
1246	644	Saif Uddín	{ Nasir Uddín } { Muhammad }	Do.
1253	651	Mulk Uzbek	Do.	Do.
1257	656	Jalál Uddín	Do.	Do.
1258	657	Irsailán Khán	Do.	Do.
1260	659	Tatar Khán	Do.	Do.
1277	676	Tughral Khán	Balín	Edward I.
1282	681	Nasir Uddín	Do.	Do.
1325	725	Kadr Khán	Muhammad III.	Edward II.

SECOND PERIOD.

*Independent Muhammadan Kings of Bengal.*

1340	741	Fakir Uddín	Muhammad III.	Edward III.
1343	743	Ilyas Sháh	Do.	Do.
1358	760	Sikandar Sháh	Firus III.	Do.
1367	769	Ghyyas Uddín II.	Do.	Do.
1373	775	Sultán Asalátin	Do.	Do.
1383	785	Sams Uddín	Do.	Richard II.
1385	787	Rájá Ganes	Do.	Do.
1392	794	Jalál Uddín	Muhammad IV.	Do.
1409	812	Ahmad Sháh	Mahmud III.	Henry IV.
1426	830	Nasir Sháh	Mubárik II.	Henry VI.
1457	862	Barbek Sháh	Belolí Ladi	Do.
1474	879	Yusaf Sháh	Do.	Edward IV.
1482	887	Fathi Sháh	Do.	Do.
1491	896	Sultán Sháhzádeh	Sikandar	Henry VII.
1492	897	Firus Sháh	Do.	Do.
1494	899	Máhmud Sháh	Do.	Do.
1495	900	Muzaffar Sháh	Do.	Do.
1499	905	Husain Sháh	Do.	Do.
1520	927	Nasirát Sháh	Ibrahim	Henry VIII.
1533	940	Máhmud Sháh	Humáyun	Do.

THIRD PERIOD.

*Bengal under Afghán or Pathan Dynasty. (Sher Sháh.)*

1539	946	Khizr Khán	Sher Sháh	Henry VIII.
1545	952	Muhammad Sur	Saltin Sháh	Do.
1555	962	Bahádur Sháh	Muhammad Adil	Mary
1560	968	Jalál Uddín	Do.	Elizabeth
1564	971	Salaiman Keráni	Do.	Do.
1573	981	Dand Khán	Akbar	Do.

FOURTH PERIOD.

*Governors of Bengal under the Mughal Dynasty.*

1576	984	Khán Jahán	Akbar	Elizabeth
1579	987	Muzaffar Khán	Do.	Do.
1580	988	Rájá Todarmal	Do.	Do.
1582	990	Khán Asim	Do.	Do.
1584	992	Sháhbar Khán	Do.	Do.
1589	997	Rájá Mánsínah	Do.	Do.
1606	1015	Kutal Uddín Kokaltsh	Jahángir	James I.
1607	1016	Jahángir Kuli	Do.	Do.

## FOURTH PERIOD—Continued.

A.D.	A.E.	Governors of Bengal.	Emperors of Hindustan.	Kings of England.
1608	1017	Shaikh Idris Khán	Jahángir	James I.
1618	1023	Kasim Khán	Do.	Do.
1618	1023	Ibrahim Khán	Do.	Do.
1622	1029	Sháh Jahán	Do.	Do.
1622	1029	Khanasád Khán	Do.	Charles I.
1626	1035	Makarram Khán	Do.	Do.
1627	1036	Fidai Khán	Do.	Do.
1628	1037	Kasim Khán Jabuni	Sháh Jahán	Do.
1632	1042	Asim Khán	Do.	Do.
1637	1047	Islam Khán Mashedi	Do.	Do.
1639	1049	Sultán Shajá	Do.	Do.
1660	1070	Mír Jámá	Aurangzeb	Charles II.
1664	1074	Shahistá Khán	Do.	Do.
1677	1087	Fidai Khán	Do.	Do.
1678	1088	Sultán Muhammad Asim	Do.	Do.
1680	1090	Shahistá Khán	Do.	Do.
1689	1099	Ibrahim Khán II.	Do.	William III.
1697	1108	Asim Ushán	Do.	Anne
1704	1116	Muráhid Kuli	Do.	George II.
1725	1139	Shujá Uddin Khán	Muhammad Sháh	Do.
1789	1151	Berjárás Khán	Do.	Do.
1740	1153	AM Vardi Khán	Do.	Do.
1756	1170	Shiráj Ud Daulá	Alamgir	Do.

The above chronology is taken from Stewart's *History of Bengal*.

## FIFTH PERIOD.

## Governors of Bengal and Governors-General of India under the East India Company, 1765-1854.

1765, Lord Clive; 1767, Harry Verelst; 1769, John Cartier; 1772, Warren Hastings; 1785, Sir John Macpherson; 1786, Marquis Cornwallis; 1798, Sir John Shore (Lord Teignmouth); 1798, Sir Alured Clarke (*pro tem.*); 1798, Marquis Wellesley; 1805, Marquis Cornwallis; 1806, Earl of Minto; 1813, Marquis of Hastings; 1823, John Adam (*pro tem.*); 1823, Earl Amherst; 1823, Lord William Cavendish Bentinck; 1835, Sir Charles Metcalfe; 1836, Earl Auckland; 1842, Earl of Ellenborough; 1844, Viscount Hardinge; 1848, Marquis of Dalhousie.

## SIXTH PERIOD.

## Bengal under Lieutenant-Governors, 1854-1874.

Sir Frederic Halliday; Sir John Peter Grant; Sir Cecil Beadon; Sir William Grey; Sir George Campbell; Sir Richard Temple.

*English connection with Bengal.*—The East India Company formed its earliest settlements in Bengal in the first half of the 17th century. These settlements were of a purely commercial character. In 1620 one of the Company's factors dates from Patná; in 1624-36 the Company established itself, by the favour of the emperor, on the ruins of the ancient Portuguese settlement of Pippli, in the north of Orissa; in 1640-42 the patriotism of an English surgeon, Mr Gabriel Boughton, obtained for us establishments at Balasor, also in Orissa, and at Húghl, some miles above Calcutta. The vexations and extortions to which the Company's early agents were subjected more than once almost induced them to abandon the trade, and in 1677-78 they threatened to withdraw from Bengal altogether. In 1686, the Bengal factors, driven to extremity by the oppression of the Mughul governors, threw down the gauntlet; and after various successes and hair-breadth escapes, purchased from the grandson of Aurangzeb in 1696, the villages which have since grown up into Calcutta, the metropolis of India. During the next fifty years the English had a long and hazardous struggle alike with the Mughul governors of the province and the Marhattá armies which invaded it. In 1756 this struggle culminated in the great outrage known as the Black Hole of Calcutta, followed by Clive's battle of Plassey and capture of Calcutta, which avenged it. That battle, and the subsequent years of confused fighting, established our military supremacy in Bengal, and procured the treaties of 1765, by which the provinces of Bengal, Behar, and Orissa passed

under our administration. To Warren Hastings (1772-85) belongs the glory of consolidating our power, and converting a military occupation into a stable civil government. To another member of the civil service, John Shore, afterwards Lord Teignmouth (1786-93), is due the formation of a regular system of Anglo-Indian legislation. Acting through Lord Cornwallis, then Governor-General, he ascertained and defined the rights of the landholders in the soil. These landholders under the native system had, for the most part, started as collectors of the revenues, and gradually acquired certain prescriptive rights as quasi-proprietors of the estates entrusted to them by the Government. In 1793 Lord Cornwallis declared their rights perpetual, and made over the land of Bengal to the previous quasi-proprietors or *samindars*, on condition of the payment of a fixed land tax. This great piece of legislation is known as the Permanent Settlement of the Land Revenue. But the Cornwallis code, while defining the rights of the proprietors, failed to give adequate recognition to the rights of the under-tenants and the cultivators. His Regulations formally reserved the latter class of rights, but did not legally define them, or enable the husbandmen to enforce them in the courts. After half a century of rural disquiet, the rights of the cultivators were at length carefully formulated by Act X. of 1859. This measure, now known as the land law of Bengal, effected for the rights of the under-holders and cultivators what the Cornwallis code in 1793 had effected for those of the superior landholders. The status of each class of person interested in the soil, from the Government as suzerain, through the *samindars* or superior landholders, the intermediate tenure-holders, and the under-tenants, down to the actual cultivator, is now clearly defined. The Act dates from the first year after the transfer of India from the Company to the Crown; for, meanwhile, the mutiny had burst out in 1857. The transactions of that revolt chiefly took place in Northern India, and will be found under the article on the North-Western Provinces; the uprising, although fierce and for a time perilous to our supremacy, was quickly put down. In Bengal it began at BARRACPOUR (*q.v.*), was communicated to Dacca in Eastern Bengal, and for a time raged in Behar, producing the memorable defence of the billiard-room at Arrah by a handful of civilians and Sikhs,—one of the most splendid pieces of gallantry in the history of the British arms. Since 1858, when the country passed to the Crown, the history of Bengal has been one of steady and peaceful progress. The two great lines of railway, the East India and the Eastern Bengal, have been completed; and a third, the Northern Bengal Railway, is now in progress. Trade has enormously expanded; new centres of commerce have sprung up in spots which not long ago were silent jungles; new staples of trade, such as tea and jute, have rapidly attained importance; and the coal-fields and iron ores are beginning to open up prospects of a new and splendid era in the internal development of the country.

The best account of Bengal as at present constituted is to be found in the administration reports of Sir George Campbell, K.C.S.I., when Lieutenant-governor of Bengal, in 1871-72 and 1872-73. These reports are of an official character, and embody the results of the census of 1872. Among non-official works Colonel Dalton's great volume on *The Ethnology of Bengal* holds a conspicuous place. This splendid quarto condenses the personal observations of a long career spent among the people. Stewart's *History of Bengal*, a work which was admirable when first published, is now fifty years out of date, and stands in much need of re-editing. The journals of the Asiatic societies in London, Paris, and especially Calcutta, are still the great storehouses for original research. The *Calcutta Review* contains many valuable articles, which the index to its first fifty volumes renders easily available. The present writer has endeavoured in his *Annals of Rural Bengal*; and in his two volumes on *Orissa*; or, *The Vicissitudes of an Indian Province under Native and British Rule*, to present to the general reader the result of his researches with regard to this part of India. (W. W. H.)

**BENGAZI**, a seaport town on the northern coast of Africa, and capital of the province of Barca, is situated on a narrow strip of land between the Gulf of Sidra and a salt lake, in 30° 7' N. lat. and 30° S' E. long. Though for the most part poorly built, it has one or two buildings of some pretension—an ancient castle, a mosque, a Franciscan monastery, Government buildings, and barracks. The wells in the town being brackish, drinking water has to be brought from the village of Sowani. The harbour is almost rendered useless by accumulations of sand, and ships have to discharge by means of lighters. Legitimate trade has recently been neglected by the inhabitants, who find it more profitable to furnish slaves to the Alexandrian market. The exports, which consist chiefly of sheep, wool, barley, wheat, butter, and salt, amounted in 1874 to £279,000, while the imports, of which the most important item is cloth goods, were valued at £162,600. Consuls are maintained at Bengazi by England and Italy, and France is represented by a vice-consul. The population, estimated in 1862 at 6000 or 7000, has since undergone various fluctuations, and suffered especially from an epidemic in 1872.

**BENGEL, JOHN ALBERT**, a celebrated Biblical scholar and critic, was born at Winnenden, in Württemberg, on the 24th June 1687. His father, who was one of the ministers of that town, having died when Bengel was only six years old, his education was taken in hand by a friend of his father named Spindler, who having afterwards become a master in the gymnasium at Stuttgart, carried the boy thither with him, and superintended his education until he entered the University of Tübingen in the year 1703. While at the university, the works to which, among others, he gave special attention as private studies were those of Aristotle and Spinoza, and so thoroughly did he make himself acquainted with the metaphysics of the latter, that he was selected by one of the professors to prepare materials for a treatise *De Spinozismo* which the professor afterwards published. He himself used to express his "great thankfulness for the benefit which he had derived from the study of metaphysics and mathematics, in respect of the clearness of thought which they imparted, which was of the utmost value to him in the analysis and exposition of the language of Scripture." After taking his degree, Bengel devoted himself to the study of theology, to which the grave and religious tone of his mind, deepened and strengthened by his early training and discipline, naturally inclined him. Like other young men of thoughtful character, before and since, he had to struggle with doubts and difficulties of a religious nature, and he alludes, with much feeling, to the "many arrows which pierced his poor heart, and made his youth hard to bear." It is interesting to know that at this early date his attention was directed to the various readings of the Greek New Testament, and that one cause of his mental perplexities was the difficulty of ascertaining the true reading among the great number of those which were presented to his notice. In 1707 Bengel entered the church, and was appointed to the parochial charge of Metzingen-unter-Urach. Here he remained only one year, and during that time devoted himself to the study of the writings of Spenser, Arndt, A. H. Franke, and Oehmnitz. The profound impression which the works of these men made upon his mind was never effaced, and may be traced in that vein of devotional, not to say pietistic, feeling which runs through all his religious compositions. In 1708 Bengel was recalled to Tübingen to undertake the office of *Repetent* or theological tutor. Here he remained until 1713, when he was appointed the head of a seminary recently established at Denkendorf and intended as a preparatory school of theology. Before entering on his duties there, he made a literary journey

through the greater part of Germany, to acquaint himself with the various systems of education which were in use, in order to qualify himself for the better discharge of his official duties. In prosecuting the journey he visited with laudable impartiality the seminaries of the Jesuits as well as those of the Lutheran and Reformed Churches. Among other places he visited Heidelberg and Halle, and had his attention directed at the former city to the canons of Scripture criticism published by Gerhard von Mästricht, and at the latter to Vitringa's *Anacrisis ad Apocalypsin*. The influence exerted by these upon his theological studies will be apparent when we come to notice his works upon the criticism and interpretation of Scripture. For twenty-eight years—from 1713-1741—he discharged his important duties as head of the school of Denkendorf with distinguished ability and success, devoting all his energies to the religious and intellectual improvement of his students. It is impossible to read the extracts from his diary and correspondence, which have been preserved, without being struck with the spirit of fervent piety, combined with sagacity and good sense, which characterized his management of the institution. These twenty-eight years were the period of Bengel's greatest intellectual activity, many of the works on which his reputation rests being included within them. In 1741 he was appointed prelate of the cloister of Herbrechtingen, an office which he held for eight years. In 1749 he was raised to the dignity of consistorial counsellor and prelate of Alpirsbach, with a residence in Stuttgart. Bengel henceforth devoted himself to the discharge of his duties as a member of the consistory. A question of considerable difficulty was at that time occupying the attention of the church courts, viz. the manner in which those who separated themselves from the church were to be dealt with, and the amount of toleration which should be accorded to meetings held in private houses for the purpose of religious edification. The civil power (the duke of Württemberg was a Roman Catholic) was disposed to have recourse to measures of repression, while the members of the consistory, recognising the good effects of such meetings, were inclined to concede a considerable degree of liberty. Bengel exerted himself on the side of the latter. The admirer of Spenser, the founder of the *collegia pietatis*, could not but show himself favourably disposed to meetings held for religious purposes, and while maintaining the rights and privileges of the church, he was an advocate for all reasonable freedom being accorded to those who felt themselves bound on grounds of conscience to withdraw from her communion. The good effects of this policy may be seen at this day in the attitude taken up by those who in Württemberg have separated from the church. Bengel's public position necessarily brought him into contact with many individuals of celebrity, by whom he was consulted on all important theological and ecclesiastical questions. In a single year he received no fewer than 1200 letters. In the year 1751 the University of Tübingen, his own *alma mater*, conferred upon him the degree of doctor of divinity. Bengel's life was now drawing to a close. He died, after a short illness, in 1753, aged sixty-five years and four months. He himself is reported to have said, "I shall be forgotten for a while, but I shall again come into remembrance;" and his favourite pupil Oettinger remarked of him, "His like is not left in Württemberg."

The works on which Bengel's reputation rests as a Biblical scholar and critic are, his edition of the Greek New Testament, and his *Gnomon* or *Theological Commentary* on the same.

(A.) His edition of the Greek Testament was published in 4to at Tübingen in 1754, and in 8vo at Stuttgart in the same year, but without the critical apparatus. So early as 1725 he had given an account in his *Protronus Novi Testamenti Græci vocis oculique adornandi* of the principles on which his intended edition was to be based. In preparation for his work Bengel was able to avail himself of the collations of upwards of twenty MSS., none of them, however,

of great importance, twelve of which had been collated by himself. In constituting the text, he imposed upon himself the singular restriction of not inserting any various reading which had not already been printed in some preceding edition of the Greek text. From this rule, however, he deviated in the case of the Apocalypse, where, owing to the corrupt state of the text, he felt himself at liberty to introduce some readings on manuscript authority. In the lower margin of the page he inserted a selection of various readings, the relative importance of which he denoted by the first five letters of the Greek alphabet in the following manner:— $\alpha$  was employed to denote the reading which in his judgment was the true one, although he did not venture to place it in the text;  $\beta$ , a reading better than that in the text;  $\gamma$ , one equal to the textual reading;  $\delta$  and  $\epsilon$ , readings inferior to those in the text. Stephens's division into verses was retained in the inner margin, but the text was divided into paragraphs. The text was followed by a critical apparatus, the first part of which consisted of an introduction to the criticism of the New Testament, in the thirty-fourth section of which he laid down and explained his celebrated canon, "*Proclivi Scripturæ præsertim ardua*" ("The more difficult reading to be preferred to that which is more easy"), the soundness of which, as a general principle, has been recognized by succeeding critics, although it was objected to by his great opponent Wetstein, who, nevertheless, found "himself ultimately obliged to lay down something nearly to the same effect" (Scrivener). The second part of the critical apparatus was devoted to a consideration of the various readings, and here Bengel adopted the plan of stating the evidence both *against* and *in favour* of a particular reading, thus placing before the reader the materials for forming a judgment. It is a proof of Bengel's great critical sagacity that he was the first definitely to propound the theory of families or recensions of MSS. His investigations had led him to see that a certain affinity or resemblance existed amongst many of the authorities for the Greek text—MSS., versions, and ecclesiastical writers; that if a peculiar reading, e.g., were found in one of these, it was generally found also in the other members of the same class; and this general relationship seemed to point ultimately to a common origin for all the authorities which presented such peculiarities. Although disposed at first to divide the various documents into three classes, he finally adopted a classification into two—the African, or older family of documents, and the Byzantine, or more recent class, to which he attached only a subordinate value. The theory was afterwards adopted by Semler and Griesbach, and worked up into an elaborate system by the latter critic. Bengel's labours on the text of the Greek Testament were received with great disfavour in many quarters. Like Walton and Mill before him, he had to encounter the opposition of ignorant and fanatical individuals who believed that the certainty of the Word of God was endangered by the importance attached to the various readings, as if the received text were possessed of infallible authority. One of his opponents, Provost Kohler, publicly challenged him to put the enemies of criticism to silence by admitting that even the various readings were given by inspiration, in order to meet the necessities of various classes of readers! Wetstein, on the other hand, accused him of excessive caution in not making freer use of his critical materials. In answer to these strictures, Bengel published a *Defence of the Greek Text of the New Testament*, which he prefixed to his *Harmony of the Four Gospels*, published in 1736, and which contained a sufficient answer to the misrepresentations, especially of Wetstein, which had been brought against him from so many different quarters. The text of Bengel long enjoyed a high reputation amongst scholars, and was frequently reprinted.

(B.) The other great work of Bengel, and that on which his reputation as an exegete is mainly based, is his *Gnomon, or Exegetical Annotations on the New Testament*, published in 1742. It was the fruit of twenty years' labour, and exhibits with a pregnant brevity of expression, which, it has been said, "condenses more matter into a line than can be extracted from pages of other writers," the results of his study of the sacred volume. He modestly entitled his work a *Gnomon* or index, his object being rather to guide the reader to ascertain the meaning for himself, than to save him from the trouble of personal investigation. The principles of interpretation on which he proceeded were, to import nothing into Scripture, but to draw out of it everything that it really contained, in conformity with grammatico-historical rules; not to be hampered by dogmatical considerations; and not to be influenced by the symbolical books. Bengel's hopes that the *Gnomon* would help to rekindle a fresh interest in the study of the New Testament was fully realized. It has passed through many editions (latest 1850), has been translated into German and into English, and is still one of the books most highly prized by the expositor of the New Testament. It is a striking testimony to its value that John Wesley largely availed himself of it in writing his *Expository Notes upon the New Testament*, 1755, saying that he "believed he would much better serve the interests of religion by translating from the *Gnomon* than by writing many volumes of his own notes." Later commentators have not failed to follow Wesley's example.

Besides the two works already described, Bengel was the editor or author of many others, classical, patristic, ecclesiastical, and expository, which our limits do not allow us to discuss. We can only name two, viz., *Ordo Temporum*, a treatise on the chronology of Scripture, in which he enters upon speculations regarding the end of the world, and an *Exposition of the Apocalypse*, which enjoyed for a time extraordinary popularity in Germany, and was translated into several foreign languages.

For full details regarding Bengel the reader is referred to the *Memoir of his Life and Writings*, by J. C. F. Burk, translated into English by Rev. E. F. Walker, London, 1837. (P. C.)

BENGUELA, a country on the western coast of Africa, situated to the south of Angola, between 10° and 17° S. lat., and extending from the River Coanza to the Cuanza, which is otherwise known as Nourse, Rio das Trombas, Rio dos Elephantes. The country rises from the coast inwards till it attains a decidedly mountainous character. There is great abundance both of vegetable and animal life; and the higher regions contain mines of copper, silver, iron, and salt. The inhabitants belong to the Congo race and speak the Bunda language. In 1617 the Portuguese under Manoel Cerveira Pereira founded the town of S. Felipe de Benguela near the mouth of the Cavaco, on the Bahia das Vacas (Santo Antonio, or Cone's Bay), in 12° 34' S. lat. and 13° 20' E. long. It was long the centre of an important trade, especially in slaves, but has now greatly declined. There is but little traffic, and no manufactures. Besides the churches of S. Felipe and S. Antonio, the hospital, and the fortress, there are only a few stone-built houses. The negro town of Catombela, about 8 miles distant, is in a more flourishing condition. A short way below Benguela is Bahia Tarta, where salt is manufactured and sulphur excavated. The town of Old Benguela is situated about 130 miles to the N.; and about 80 miles in that direction lies the Presidio of Novo Redondo, where fortifications were erected in 1769. Among the more important inland towns are Bibé, Bailundo, and Caconda, in the last of which the Portuguese have long had a fortress. The southern portion of Benguela forms the separate government of Mossamedes, of which the capital of the same name is situated on the Bay of Mossamedes at the mouth of the River Béro (Rio das Mortes). The bay was formerly called Angra do Negro, and received its present designation in honour of Baron Mossamedes about 1785. The town, which is known to the natives as Mossongo-Bittolo, was not founded till 1840. The population of the whole territory of Benguela is estimated at about 140,000.

BENICARLO, a city of Spain, in the province of Castellon, on the coast of the Mediterranean. It is surrounded by ancient walls, and has a ruined castle. The manufacture of brandy is carried on, and the town is celebrated for its red wine, which is annually exported to Bordeaux for mixing with clarets and other French wines. The value of wine exported in 1869 was £9500. Population, 7000.

BENIN, a country, city, and river of Western Africa, to the west of the main channel of the Niger. The name was formerly applied to the whole stretch of coast from the Volta, in 0° 40' E. long., to the Rio del Rey or Riumbi, in 8° 40' E. long., including what is now known as the Slave Coast, the whole delta of the Niger, and a small portion of the country to the eastward; and some trace of this earlier application remains in the name of *Bight of Benin*, still given to that part of the sea which washes the Slave Coast. The kingdom of Benin seems at one time to have been one of the most powerful of Western Africa, and was known to Europeans in the 17th century as the Great Benin. Budagy and Lagos, now British possessions, are both Beninese colonies. Benin has now been long in a state of decline, and the territory is broken up into independent states of no individual importance. Such coherence, indeed, as still exists is rather ethnographical

than territorial; but it may be regarded as bounded on the E. by the Niger, N. by the Yoruba country, and W. by Egba. The soil is highly fertile and produces palms, rice, beans, maize, kokos, plantains, cotton, sugar, and Guinea pepper, in great abundance. The papaw and African plum grow wild, and excellent tobacco can be raised. Many parts of the country are covered with almost impenetrable forests and swamps, but towards the north there is fine pasture land, in which the natives rear both cattle and horses of considerable value. Of trees the cotton wood, the tamarind, and the mangrove are the most frequent. The population is pretty dense, and it is said that in the most flourishing state of the kingdom the king could collect 100,000 men. His rule is absolute, and he is revered by his subjects as a species of divinity. It is a crime to believe that the king either eats or sleeps; and all offences against him are punished with the utmost severity. The religion and mythology agree with the great system of Yoruba and Oro; the chief god is worshipped with human sacrifices to an appalling extent. The people, at the same time, do not indulge in wanton cruelty; they usually stupefy the victims before putting them to death. The houses, at least of the better classes, are built on a plan similar to that of the Romans, with a regular *atrium* and *isaplerium*. The Beninese weave their cotton into a fine kind of muslin, which is worn in huge bulging petticoats by people of wealth, while the lower orders are content with a simple *Besubo* or kilt. The capital of the kingdom, or city of Benin, is situated about 73½ miles inland from the mouth of the Rio Formoso or Benin River, about 5° 35' E. long. and 6° 25' N. lat. It covers a large extent of ground, but is so broken up into separate portions by intervening spaces of jungle, that no proper estimate can be formed of its population. The Obwo, or King's quarter, alone is supposed to have upwards of 15,000 inhabitants; but at the time of Burton's visit in 1862 many of the houses were empty and falling to ruin. The next city in importance is Wari (Owari, Awerri, or Owheyra, called Jaku by the natives), which is situated about 130 miles S.S.E. of the capital, and some 7 or 10 miles from the sea, on an island surrounded by a branch of the Niger distinguished by the same name. It was formerly described as consisting of two parts about half a mile distant from each other, but now consists of one long and straggling line along the shore. The population previously stated at 5000 is reduced by Burton to 2000. The town, however, has its own king, who has long asserted his independence of the monarch of Benin. The houses are neatly built of clay, coloured with red ochre, and frequently ornamented with rudely carved pillars. The port of Gwato (or as it is variously called, Gato, Agatho, or Agatton) lies about 30 miles N.N.E. of the mouth of the Benin River, is a place of some importance for the palm-oil trade, and has a special interest as the place where Balzoni, the traveller, died and was buried. Numerous factories are scattered along the creeks of the delta for the purposes of trade, but all the larger European settlements have disappeared. Since the abolition of the slave trade the chief export of the country is palm-oil, in return for which salt, silk stuffs, guns and gunpowder, coral (which is the official decoration of the higher dignities), beads, iron, brass, and brandy are imported. The common internal currency is the cowrie-shell.

The River Benin, called by the natives Uwo Ko Jakri, or Outlet of Jakri, is about two miles broad at its mouth; but it is crossed by a very extensive bar of mud and sand, on which there is only 12 feet of water at spring tides. Ships of 60 tons can ascend as far as Gwato.

Benin was discovered by the Portuguese about the year 1485, and they carried on for some time a brisk trade in slaves, who were

carried to Elmina, and sold to the natives of the Gold Coast. John III. of Portugal, however, prohibited this traffic; and, as the situation was found very unhealthy, the settlement was ordered to be withdrawn. Many traces of the Portuguese occupation are still to be found, and one of the most striking proofs of their influence is the fact that a corrupt Lusitanian dialect is still spoken by the older natives. The Dutch afterwards established factories, and maintained them for a considerable time, chiefly with a view to the slave trade. In 1788 Captain Landolphe founded a factory called Barodo, near the native village of Obobi, for the French Compagnie d'Oywhéré; and it lasted till 1792, when it was destroyed by the English. See Bosman's *Description of the Coast of Guinea* in 1705 (in vol. xvi. of Pinkerton's *Voyages*); William Smith's *New Voyage to Guinea*, 1744; Adams's *Remarks on the West Coast of Africa*, 1823; Clapperton's *Second Expedition*, 1829; Lander's *Travels*, 1832; Burton's *My Wanderings in West Africa*, 1863.

**BENJAMIN** (בִּנְיָמִן, Sept. *Bennamé*), the youngest son of the patriarch Jacob, by Rachel. His mother, dying in childbed, gave him the name Benoni. "Son of my pain," which was changed by his father to Benjamin, meaning probably "Son of the right hand," that is, "Son of prosperity" (Gen. xxxv. 16-18). Of his personal history little is recorded. He was the favourite of his father and brothers, and seems to have been of an amiable though somewhat weak character. In this respect he strikingly contrasts with the tribe, whose history was foretold in the dying prophecy of Jacob, "Benjamin shall ravine as a wolf" (Gen. xlix. 27). The tribe of Benjamin, though the least numerous of Israel, became nevertheless a considerable race. In the desert it counted 35,400 warriors (Num. i. 37), and at the entrance of Israel into Canaan even as many as 45,600 (Num. xxvi. 41). The portion allotted to this tribe was encompassed by the districts of Ephraim, Dan, and Judah. In the time of the judges the tribe of Benjamin became involved in a civil war with the other eleven tribes, which terminated in its almost utter extinction, 600 men alone escaping (Judges xix., xx.). The tribe speedily revived, however; in the time of David it numbered 59,434 able warriors, and in that of Ase, 280,000. This tribe had the honour of giving the first king to the Jews, Saul being a Benjamite. After the death of Saul, the Benjamites declared themselves for his son Ishboaheth, until, after the assassination of that prince, David became king of all Israel. David having expelled the Jebusites from Zion, and made it his own residence, the close alliance that previously existed between the tribes of Benjamin and Judah was cemented by the circumstance that, while Jerusalem belonged to the district of Benjamin, that of Judah was immediately contiguous to it. At the division of the kingdom after the death of Solomon, Benjamin espoused the cause of Judah, and they formed a kingdom by themselves. Indeed, the two tribes stood always in such a close connection as often to be included under the single name Judah.

**BENJAMIN**, of Tudela, in Navarre, a celebrated Jewish rabbi of the 13th century, whose *Itinerary* is a literary curiosity. He visited Constantinople, Egypt, Assyria, and Persia, penetrating to the frontiers of China. He was credulous, but his work contains some curious notices of the countries he visited. It was translated from the Hebrew into Latin by Arias Montanus in 1576, and appeared in a French version by Barastier in 1734, and again in 1830. The latest English translation is that by Asher, 1840.

**BENNET**, HENRY, Earl of Arlington, a distinguished statesman in the reign of Charles II., was born of an ancient family in Middlesex, in the year 1618. In the beginning of the civil war he was appointed under-secretary to Lord Digby, secretary of state. He afterwards entered himself as a volunteer for the royal cause, and did the king good service, especially at Andover in Hampshire, where he was severely wounded. He was made secretary to the Duke of York, received the honour of knighthood from Charles II. at Bruges in 1658, and was sent as envoy

to the court of Spain. Upon the return of the king to England he was called home, made keeper of the privy purse, and principal secretary of state. In 1670 he was of the council distinguished by the title of the Cabal, and one of those who advised the shutting up of the exchequer. In 1672 he was made Earl of Arlington and Viscount Thetford, and soon after knight of the garter.

"Henry Bennet, Lord Arlington, then secretary of state, had, since he came to manhood, resided principally on the Continent, and had learned that cosmopolitan indifference to constitutions and religions which is often observable in persons whose life had been passed in vagrant diplomacy. If there was any form of government he liked, it was that of France. If there was any church for which he felt a preference, it was that of Rome. He had some talent for conversation, and some talent also for transacting the ordinary business of office. He had learned, during a life passed in travelling and negotiating, the art of accommodating his language and deportment to the society in which he found himself. His vivacity in the closet amused the king; his gravity in debates and conferences imposed on the public; and he had succeeded in attaching to himself, partly by services and partly by hopes, a considerable number of personal retainers."—(Macaulay's *Hist.*, vol. i. pp. 230-21.)

He died in 1685. His *Letters to Sir William Temple* were published after his death.

BENNETT, JAMES GORDON, American journalist, originator and editor of the *New York Herald*, was by birth a Scotchman. He was born at Newmills in Banffshire, about 1800. Destined for the priesthood in the Roman Catholic Church, he was educated in a seminary at Aberdeen. But it became evident that he was naturally unfit for the priestly calling; and his aversion ripened into a determination to escape from it. The reading of Franklin's *Autobiography* led him to resolve on emigration to America, and in the spring of 1819 he sailed for the New World. Landing at Halifax, he earned a poor living there for a short time by giving lessons in French, Spanish, and bookkeeping; he passed next to Boston, where starvation almost threatened him till he got employment in a printing-office; and in 1822 he went to New York. An engagement as translator of Spanish for a newspaper took him for a few months to Charleston, South Carolina. On his return to New York he projected a school, gave lectures on political economy, and did subordinate work for the journals. In 1825 he made his first attempt to establish a journal of his own; and the next ten years were occupied in a variety of similar attempts, which proved futile. During that period, however, he became Washington correspondent of the *Inquirer*; and his letters, written in imitation of the letters of Horace Walpole, attracted attention. Notwithstanding all his hard work and his resolutely abstemious life, he was still a poor man. It was not till 1835 that he struck the vein which was to reward and enrich him. On May 6 of that year appeared the first number of a small one-cent paper, bearing the title of *New York Herald*, and issuing from a cellar, in which the proprietor and editor played also the part of salesman. "He started with a disclaimer of all principle, as it is called, all party, all politics;" and to this he certainly adhered. By his immense industry and practical sagacity, his unscrupulousness, variety of news, sly correspondence, supply of personal gossip and scandal, the paper became a great commercial success. Bennett continued to edit the *Herald* till his death. The successful mission of Stanley to Central Africa in search of Dr Livingstone, of whom nothing had long been heard, was undertaken by his desire and at his expense; and he thus shined in the last year of his life the inextinguishable spirit of enterprise which had animated him throughout his whole career. He died at New York, June 2, 1872.

BENNETT, JOHN HUGHES, for twenty-six years professor of the institutes of medicine at Edinburgh University, was born in London on the 31st August 1812. He was edu-

ated at Exeter, and being destined for the medical profession was articled to a surgeon in Maidstone. In 1833 he began his studies at Edinburgh, and in 1837 graduated with the highest honours. During the next four years he studied in Paris and Germany, and on his return to Edinburgh in 1841 published a work on cod-liver oil, the recommendation of which as a remedy in all consumptive diseases made his name widely known. In 1848 he obtained the chair of institutes of medicine, having already gained high reputation as an extra-academical lecturer and teacher. In 1871 his health gave way; he retired to the south of France, and in 1874 resigned his professorship. In August 1875 he was able to be present at the meeting of the British Medical Association in Edinburgh, on which occasion he received the degree of LL.D. The fatigue he then underwent brought on a relapse, and he was compelled to have the operation of lithotomy performed. He sank rapidly and died on the 26th September. Professor Bennett was an able teacher, and his original investigations entitle him to a high place in the history of medicine. His publications are very numerous, including many articles in medical journals and several exhaustive treatises. Of these the best known are *Clinical Lectures*, 1858 (5th ed., 1868); *Treatise on Physiology*, 1858, contributed to the 8th edition of the *Encyclopædia Britannica*; *Text-book of Physiology*, 1870.

BENNETT, SIR WILLIAM STRENDAL, was considered, for more than the last 20 years of his life, the head of the musical profession in England by the unanimous verdict of both English and foreign musicians. At his death he received the highest honour England can confer upon her sons—a grave in Westminster Abbey. He was born in 1816 at Sheffield, where his father was organist. Having lost his father at an early age, he was brought up at Cambridge by his grandfather, from whom he received his first musical education. In 1826 he entered the Royal Academy of Music, and remained a pupil of that institution for the next ten years, studying pianoforte and composition under Cipriani Potter, Dr Crotch, W. H. Holmes, and C. Lucas. It was during this time that he wrote several of his most appreciated works, not uninfluenced it seems by the contemporary movement of musical art in Germany, which country he frequently visited during the years 1836-42. At one of the Rhenish musical festivals in Düsseldorf he made the personal acquaintance of Mendelssohn, and soon afterwards renewed it at Leipzig, where the talented young Englishman was welcomed by the leading musicians of the rising generation. He played at one of the celebrated Gewandhaus concerts his third pianoforte concerto, which was received by the public in a manner flattering both to the pianist and the composer. We still possess an enthusiastic account of the event from the pen of Robert Schumann, whose genial expansive nature was always open to new impressions. He never tired of Bennett's praise, whom he pronounced to be "the most musical of all Englishmen," and whom, in a private letter, he goes so far as to call "an angel of a musician." But even Schumann could not wholly conceal from himself the influence which Mendelssohn's compositions exercised on Bennett's mode of utterance, an influence which precluded the possibility of an original development to a degree almost unequalled in the history of music, excepting perhaps the case of the Danish composer Niels W. Gade, who like Bennett was attracted to Leipzig by the fame of Mendelssohn, and who like him offered his own artistic individuality at the shrine of the German composer's genius. According to a tradition, the late Professor Hauptmann, after listening to a composition by Gade, is said to have pronounced the sarcastic sentence, "This sounds so much like Mendelssohn, that one might

almost suppose it to be written by Sterndale Bennett.<sup>o</sup> It would lead us too far on the present occasion to point out how, by this subserviency of the leading English musician to a foreign composer, the national development of English art was impeded in a deplorable manner. His great success on the Continent established Bennett's position in England. He settled in London, devoting himself chiefly to practical teaching. For a short time he acted as conductor of the Philharmonic Society, in which capacity, however, he earned little success. He was made musical professor at Cambridge in 1856, and in 1868 principal of the Royal Academy of Music. In 1871 he received the honour of knighthood. He died in 1875. Owing most likely to his professional duties his latter years were not fertile, and what he then wrote was not superior, scarcely equal, to the productions of his youth. The principal charm of Bennett's compositions (not to mention his absolute mastery of the musical form) consists in the tenderness of their conception, rising occasionally to sweetest lyrical intensity, but also bordering now and then on that excessive sentimentalism from which his master Mendelssohn kept not always aloof. It must, however, be acknowledged that Bennett's was a thoroughly refined nature, incapable of grand dramatic pathos, but also free from all inartistic pandering to the taste of the vulgar. Barring the opera, Bennett tried his hand at almost all the different forms of vocal and instrumental writing. As his best works in various branches of art, we mention, for pianoforte solo, and with accompaniment of the orchestra, his three sketches, *The Lake, the Millstream, and the Fountain*, and his 3d pianoforte concerto; for the orchestra, his Symphony in G minor, and his overture *The Naiads*; and for voices, his cantata *The May Queen*, written for the Leeds festival in 1858. He also wrote a sacred cantata, *The Woman of Samaria*, first performed at the Birmingham Musical Festival in 1867. Shortly before his death he produced a sonata called the *Maid of Orleans*, an elaborate piece of programme-music, descriptive of the deeds and sufferings and the final triumph of the French heroine according to Schiller's tragedy.

**BENSERADE, ISAAC DE**, a French poet, was born in 1612 at Lions-la-Forêt in Normandy. He made himself known at court by his verses and his wit, and had the good fortune to please the cardinals Richelieu and Mazarin. He wrote—1. A Paraphrase upon Job; 2. Verses for Ballets or Interludes; 3. Rondeaux upon Ovid; 4. Several Tragedies. A sonnet of his, which he sent to a young lady with his paraphrase on Job, having been placed in competition with the *Uranis* of Voiture, a dispute on their relative merits long divided the whole court and the wits into two parties, who were respectively styled the *Jobelins* and the *Uranists*. Some years before his death in 1691 Benserade retired to Chantilly, and devoted himself to a translation of the Psalms, which he nearly completed.

**BENSON, GEORGE**, a learned dissenting minister, was born at Great Salkeld, in Cumberland, in 1699. His mental capacity was so precocious, that at 11 years of age he was able to read the Greek Testament. He afterwards studied at an academy at Whitehaven, whence he removed to the University of Glasgow. In 1721 he was chosen pastor of a congregation of dissenters at Abingdon, in Berkshire, where he continued till 1729, when he became the choice of a congregation in Southwark; and in 1740 he was appointed by the congregation of Crutched Friars colleague to the learned Dr Lardner. His *Defence of the Reasonableness of Prayer* appeared in 1731, and he afterwards published Paraphrases and Notes on the Epistles to the Thessalonians, Timothy, Titus, and Philemon, adding dissertations on several important subjects, particularly on inspiration. In 1735 he published his *History of the*

*First Planting of Christianity*, in 2 vols. 4to, a work of great learning and ability. He also wrote the *Reasonableness of the Christian Religion*, the *History of the Life of Jesus Christ*, a Paraphrase and Notes on the Seven Catholic Epistles, and several other works, which gained him great reputation as a scholar and theologian. He died in 1763.

**BENTHAM, JEREMY**, was born on the 15th February 1748, in Red Lion Street, Houndsditch, London, in which neighbourhood his grandfather and father successively carried on business as attorneys. His father, who was a wealthy man, and possessed at any rate a smattering of Greek, Latin, and French, was thought to have demeaned himself by marrying the daughter of an Andover tradesman, who afterwards retired to a country house near Reading, where young Jeremy spent many happy days. The boy's talents justified the ambitious hopes which his parents entertained of his future. When three years old he read eagerly such works as Rapin's *History*, and began the study of Latin. A year or two later he learnt the violin and French conversation. At Westminster school he obtained a reputation for Greek and Latin verse writing; and he was only thirteen when he was matriculated at Queen's College Oxford, where his most important acquisition seems to have been a thorough acquaintance with Sanderson's logic. He became a B.A. in 1763, and in the same year entered at Lincoln's Inn, and took his seat as a student in the Queen's Bench, where he listened with rapture to the judgments of Lord Mansfield. He managed also to hear Blackstone's lectures at Oxford, but says that he immediately detected the fallacies which underlay the rounded periods of the future judge.

Bentham's family connections would naturally have given him a fair start at the bar, but this was not the career for which he was preparing himself. He spent his time in making chemical experiments and in speculating upon legal abuses, rather than in reading Coke upon Littleton and the Reports. On being called to the bar he "found a cause or two at nurse for him, which he did his best to put to death," to the bitter disappointment of his father, who had confidently looked forward to seeing him upon the woolsack. The first fruits of Bentham's studies, the *Fragment on Government*, appeared in 1776. This masterly attack upon Blackstone's praises of the English constitution was variously attributed to Lord Mansfield, Lord Camden, and Lord Ashburton. One important result of its publication was that, in 1781, Lord Shelburne called upon its author in his chambers at Lincoln's Inn. Henceforth Bentham was a frequent guest at Bowood, where he saw the best society, and where he met Miss Caroline Fox, to whom he afterwards made a proposal of marriage. In 1785 Bentham started, by way of Italy and Constantinople, on a visit to his brother, Sir Samuel Bentham, who became a general in the Russian service; and it was in Russia that he wrote his *Defence of Usury*. Disappointed in the hope which he had entertained, through a misapprehension of something said by Lord Lansdowne, of taking a personal part in the legislation of his country, he settled down to the yet higher task of discovering and teaching the principles upon which all sound legislation must proceed. His fame spread widely and rapidly. He was made a French citizen in 1792; and his advice was respectfully received in most of the states of Europe and America, with many of the leading men of which he maintained an active correspondence. His ambition was to be allowed to prepare a code of law for his own or some foreign country. During nearly a quarter of a century he was engaged in negotiations with Government for the erection of a "Panopticon," which would render transportation unnecessary. The scheme was eventually abandoned, and Bentham received £28,000 by

way or compensation. In 1823 he established the *Westminster Review*. Some idea of the extent of Bentham's literary labours may be derived from the fact that his *Works*, as edited with biographical notices by Dr Bowring in 1843, fill eleven volumes octavo, of closely printed double columns. Bentham died on the 6th of June 1832, in his 85th year, at the house in Queen's Square Place, which he had occupied for fifty years. In accordance with his directions, his body, after being dissected in the presence of his friends, was embalmed, and is still preserved, seated in his wonted dress, in University College, London.

Bentham's life was a happy one of its kind. His constitution, weakly in childhood, strengthened with advancing years so as to allow him to get through an incredible amount of sedentary labour, while he retained to the last the fresh and cheerful temperament of a boy. An ample inherited fortune permitted him to pursue his studies undisturbed by the necessity for making a livelihood, and to maximize the results of his time and labour by the employment of amanuenses and secretaries. He was able to gather around him a group of congenial friends and pupils, such as the Mills, the Austins, and Bowring, with whom he could discuss the problems upon which he was engaged, and by whom several of his books were practically rewritten, from the mass of rough though orderly memoranda which the master had himself prepared. Thus, for instance, was the *Rationale of Judicial Evidence* written out by J. S. Mill, and the *Book of Fallacies* by Bingham. The services which Dumont rendered in recasting, as well as translating, the works of Bentham were still more important.

The popular notion that Bentham was a morose visionary is far removed from fact. It is true that he looked upon general society as a waste of time, and that he disliked poetry as "misrepresentation"; but he intensely enjoyed conversation, gave good dinners, and delighted in music, in country sights, and in making others happy. These features of Bentham's character are illustrated in the graphic account given by the American minister, Mr Rush, of an evening spent at his house in the summer of the year 1818. "If Mr Bentham's character is peculiar," he says, "so is his place of residence. It was a kind of blind-alley, the end of which widened into a small, neat courtyard. There by itself stands Mr Bentham's house. Shrubbery graced its area, and flowers its window-sills. It was like an oasis in the desert. Its name is the Hermitage. Mr Bentham received me with the simplicity of a philosopher. I should have taken him for 70 or upwards. Everything inside the house was orderly. The furniture seemed to have been unmoved since the days of his fathers, for I learned that it was a patrimony. A parlour, library, and dining-room made up the suite of apartments. In each was a piano, the eccentric master of the whole being fond of music as the recreation of his literary hours. It is a unique, romantic-like homestead. Walking with him into the garden, I found it dark with the shade of ancient trees. They formed a barrier against all intrusion. The company was small, but choice. Mr Brougham; Sir Samuel Romilly; Mr Mill, author of the well-known work on India; M. Dumont, the learned Genevan, once the associate of Mirabeau, were all who sat down to table. Mr Bentham did not talk much. He had a benevolence of manner suited to the philanthropy of his mind. He seemed to be thinking only of the convenience and pleasure of his guests, not as a rule of artificial breeding as of Chesterfield or Madame Genlis, but from innate feeling. Bold as are his opinions in his works, here he was wholly unobtrusive of theories that might not have commended the assent of all present. When he did converse it was in simple language, a contrast to his later writings, where an involved style and the

use of new or universal words are drawbacks upon the speculations of a genius original and profound, but with the faults of solitude. Yet some of his earlier productions are distinguished by classical terseness."—(*Residence at the Court of London*, p. 286.) Bentham's love of flowers and music, of green foliage and shaded walks, comes clearly out in this pleasant picture of his home life and social surroundings.

Whether or no he can be said to have founded a school, his doctrines have become so far part of the common thought of the time, that there is hardly an educated man who does not accept as too clear for argument truths which were invisible till Bentham pointed them out. His sensitively honourable nature, which in early life had caused him to shrink from asserting his belief in Thirty-nine articles of faith which he had not examined, was shocked by the enormous abuses which confronted him on commencing the study of the law. He rebelled at hearing the system under which they flourished described as the perfection of human reason. But he was no merely destructive critic. He was determined to find a solid foundation for both morality and law, and to raise upon it an edifice, no stone of which should be laid except in accordance with the deductions of the severest logic. This foundation is "the greatest happiness of the greatest number," a formula adopted from Beccaria. The pursuit of such happiness is taught by the "utilitarian" philosophy, a phrase used by Bentham himself in 1802, and therefore not invented by Mr J. S. Mill, as he supposed, in 1823. In order to ascertain what modes of action are most conducive to the end in view, and what motives are best fitted to produce them, Bentham was led to construct marvellously exhaustive, though somewhat mechanical, tables of 'motives. With all their elaboration, these tables are, however, defective, as they omit some of the highest and most influential springs of action. But most of Bentham's conclusions may be accepted without any formal profession of the utilitarian theory of morals. They are, indeed, merely the application of a rigorous common sense to the facts of society. That the proximate ends at which Bentham aimed are desirable hardly any one would deny, though the feasibility of the means by which he proposes to attain them may often be questioned; and much of the new nomenclature in which he thought fit to clothe his doctrines may be rejected as unnecessary. To be judged fairly, Bentham must be judged as a teacher of the principles of legislation. With the principles of private morals he really deals only so far as is necessary to enable the reader to appreciate the impulses which have to be controlled by law.

As a teacher of legislation he inquires of all institutions whether their utility justifies their existence. If not, he is prepared to suggest a new form of institution by which the needful service may be rendered. While thus engaged no topic is too large for his mental grasp, none too small for his notice; and, what is still rarer, every topic is seen in its due relation to the rest. English institutions had never before been thus comprehensively and dispassionately surveyed. Such improvements as had been necessitated were mere makeshifts, often made by stealth. The rude symmetry of the feudal system had been long ago destroyed by partial and unskilful adaptations to modern commercial life, effected at various dates and in accordance with various theories. The time had come for deliberate reconstruction, for inquiring whether the existence of many admitted evils was, as it was said to be, unavoidable; for proving that the needs of society may be classified and provided for by contrivances which shall not clash with one another because all shall be parts of a consistent whole. This task Bentham undertook, and he brought to it a mind absolutely free from professional or class feeling, or any other species of



prejudice. He mapped out the whole subject, dividing and subdividing it in accordance with the principle of "dichotomy." Having reached his ultimate subdivisions he subjects each to the most thorough and ingenious discussion. His earlier writings exhibit a lively and easy style, which gives place in his later treatises to sentences which are awkward from their effort after unattainable accuracy, and from the newly-invented technical nomenclature in which they are expressed. Many of Bentham's phrases, such as "international," "utilitarian," "codification," are valuable additions to our language; but the majority of them, especially those of Greek derivation, have taken no root in it. His neology is one among many instances of his contempt for the past and his wish to be clear of all association with it. His was, indeed, a typically logical, as opposed to an historical, mind. For the history of institutions, which in the hands of Sir Henry Maine is becoming a new and interesting branch of science, Bentham cared nothing. Had he possessed such a knowledge of Roman law as is now not uncommon in England, he must doubtless have taken a different view of many subjects. The logical and historical methods can, however, seldom be combined without confusion; and it is perhaps fortunate that Bentham devoted his long life to showing how much may be done by pursuing the former method exclusively. His writings have been and remain a storehouse of instruction for statesmen, an armoury for legal reformers. "Pillé par tout le monde," as Talleyrand said of him, "il est toujours riche." To trace the results of his teaching in England alone would be to write a history of the legislation of half a century. Upon the whole administrative machinery of government, upon criminal law, and upon procedure, both criminal and civil, his influence has been most salutary; and the great legal revolution which has just accomplished the fusion of law and equity is not obscurely traceable to the same source. Those of Bentham's suggestions which have hitherto been carried out have affected the matter, or contents, of the law. There seems at length some reason to hope that his suggestions for the improvement of its form and expression are about to receive the attention which they deserve. The services rendered by Bentham to the world would not, however, be exhausted even by the practical adoption of every one of his recommendations. There are no limits to the good results of his introduction of a true method of reasoning into the moral and political sciences.

The best edition of Bentham's works is that edited by Dr Bowring, in 11 vols. 8vo, the publication of which was completed in 1843. It contains a selection from his correspondence, and some biographical statements. (T. E. H.)

**BENTINCK, LORD WILLIAM GEORGE FREDERICK CAVENTISH**, better known as Lord George Bentinck, the second son of the fourth duke of Portland, by Henrietta, sister to the Viscountess Canning, was born February 27, 1802. He was educated at Eton, and at Christ Church, Oxford; after which he entered the army, and served for several years in the Guards. On retiring from the army, he acted for some time as private secretary to his uncle Mr Canning, then prime minister; in which capacity he gave proofs of high ability for the conduct of public business. In 1828 he succeeded his uncle Lord William Bentinck as member for Lynn-Regis, and continued to represent that constituency during the remaining twenty years of his life. Till within three years of his death Lord George Bentinck was little known out of the sporting world. His early attempts at public speaking afforded no indication of the abilities which the subsequent course of political events served to develop so conspicuously. His failures in the House of Commons seem to have discouraged him from the attempt to acquire reputation as a

politician. The natural energy of his character, however, found scope in another arena. As one of the leaders on "the turf," he was there distinguished by that integrity, judgment, and indomitable determination, which, when brought to bear upon matters of weightier importance, placed him, with a rapidity almost unexampled, in the foremost rank of British senators. On his first entrance into parliament he belonged to what may be called the moderate Whig party, and voted in favour of Catholic emancipation, as also for the Reform Bill, though he opposed some of its principal details. Soon after, however, he joined the ranks of the Opposition, with whom he sided up to the important era of 1846. When, in that year, Sir Robert Peel openly declared in favour of free trade, the advocates of the corn-laws, then without a leader, after several ineffectual attempts at organization, discovered that Lord George Bentinck was the only man around whom the several sections of the Opposition could be brought to rally. His sudden elevation to so prominent a position took the public mind by surprise; but he soon gave convincing evidence of powers so formidable, that the position of the Protectionist party at once assumed an imposing aspect. Towards Sir Robert Peel, in particular, his hostility was marked and uncompromising. Believing, as he himself expressed it, that that statesman and his political colleagues had "hounded to the death his illustrious relative" Mr Canning, he combined with his opposition as a political leader a degree of personal animosity that gave additional force to the poignancy of his invectives. On entering on his new position, he at once abandoned his favourite pursuits, disposed of his magnificent stud, forsook all connection with the turf, and devoted his whole time and energies to the laborious and trying duties of a parliamentary leader. Apart from the question of the corn-laws, his politics were strictly independent. In opposition to the rest of his party, he supported the bill for removing the Jewish disabilities, and was favourable to the scheme for the payment of the Roman Catholic clergy in Ireland by the landowners. As he had held no high office under Government, his qualifications as a statesman never found scope beyond the negative achievements of a leader of Opposition; but it may be safely affirmed that nothing but his untimely death could have debarred him from acquiring a distinguished position among the statesmen of Britain. This event, caused by the rupture of a vessel in the heart, took place suddenly on the 21st September 1848, while his lordship was proceeding on foot to visit a friend in the country.—(See *Lord George Bentinck; a Political Biography*, by B. Disraeli, 1851.)

**BENTIVOGLIO, GIOVANNI**, was born at Bologna about 1438, seven years before the murder of his father Annibale, then the chief magistrate of the republic. In 1462 Giovanni contrived to make himself master of the state, which he continued to rule with a stern sway for nearly half a century; but his encouragement of the fine arts, and his decoration of the city by sumptuous edifices, gilded his usurpation. He was finally expelled by Pope Julian II., in 1506, and died in the state of Milan at the age of seventy.

**BENTIVOGLIO, GUIDO**, Cardinal, an eminent statesman and historian, was born at Ferrara in 1579. After studying at Padua, he went to reside at Rome, and was received with great favour by Pope Clement VIII., who made him a prelate. He was sent as nuncio into Flanders, and afterwards to France; and when he returned to Rome he was intrusted by Louis XIII. with the management of the French affairs at that court. In 1621 he was made a cardinal, and in 1641 received the bishopric of Terracina. He was the intimate friend of Pope Urban VIII., and on the death of Urban public opinion marked out Bentivoglio

for his successor. He died suddenly, however, before the election took place. His principal works are, *Della Guerra di Fiandria, 1632-39*; *Relazioni di G. Bentivoglio in tempo delle sue Nuntature di Fiandria e di Francia, 1631*; *Memorie, 1648*; *Lettere, 1631*.

BENTLEY, RICHARD (born, 1662; died, 1743), was born at Oulton, a township in the parish of Rothwell, in the West Riding of Yorkshire. His grandfather had suffered in person and estate in the royal cause, and the family were in consequence in reduced circumstances. Bentley's mother, the daughter of a stonemason in Oulton, was a woman of excellent understanding and some education, as she was able to give her son his first lessons in Latin. From the grammar school of Wakefield Richard Bentley passed to St John's College, Cambridge, being admitted sizar in 1676. He afterwards obtained a scholarship, but never succeeded to a fellowship, being appointed by his college, before he was twenty-one, headmaster of Spalding grammar school. In this post he did not remain long, being selected by Dr Stillingfleet, Dean of St Paul's, to be domestic tutor to his son. This appointment introduced Bentley at once to the society of the most eminent men of the day, threw open to him the best private library in England, and brought him into familiar intercourse with Dean Stillingfleet, a man of sound understanding, who had not shrunk from exploring some of the more solid and abstruse parts of ancient learning. The example of such a patron seconding his natural inclinations drew Bentley into a course of thorough reading, which, however, took a philological rather than a philosophical direction. The six years which he passed in Stillingfleet's family were employed, with the restless energy characteristic of the man, in exhausting the remains of the Greek and Latin writers, and laying up those stores of knowledge upon which he afterwards drew for his various occasions.

In 1689 Stillingfleet became bishop of Worcester, and Bentley's pupil went to reside at Oxford in Wadham College, accompanied by his tutor. Bentley's introductions, and his own merits, placed him at once on a footing of intimacy with the most distinguished scholars in the university—Mill, Hody, Edward Bernard. Here he revelled in the MS. treasures of the Bodleian, Corpus, and other college libraries. He projected, and occupied himself with collections for, vast literary schemes. Among these are specially mentioned a *corpus* of the fragments of the Greek poets, and an edition of the Greek lexicographers. But his first publication was in connection with a writer of much inferior note. The Oxford press was about bringing out an edition (the *editio princeps*) of the *Chronicle of John Malalas*, from the unique MS. in the Bodleian; and the editor, Dr Mill, had requested Bentley to look through the sheets, and make any remarks on the text. This originated Bentley's *Epistola ad Millium*, which occupies less than one hundred pages at the end of the Oxford *Malalas* (*s. Theatro Sheldoniano, 1691, 8vo*). This short tractate at once placed Bentley at the head of all living English scholars. The ease with which, by a stroke of the pen, he restores passages which had been left in hopeless corruption by the editors of the *Chronicle*, the certainty of the emendation, and the command over the relevant material, are in a style totally different from the careful and laborious learning of Hody, Mill, or Chilmead. To the small circle of classical students it was at once apparent that there had arisen in England a critic, whose attainments were not to be measured by the ordinary academical standard, but whom these few pages had sufficed to place by the side of the great Grecians of a former age. Unfortunately this mastery over critical science was accompanied by a tone of self-assertion and presumptuous confidence, which not only checked admiration, but was

calculated to rouse enmity. Dr Monk, indeed, Bentley's biographer, has charged him with an indecorum of which he was not guilty. "In one place," writes Dr Monk, "he accosts Dr Mill as *τ'αυτοῦ*, an indecorum which neither the familiarity of friendship, nor the licence of a dead language, can justify towards the dignified head of a house." But the object of Bentley's apostrophe is not his correspondent Dr Mill, but his author John Malalas, whom in another place he playfully appeals to as "Syriac." From this publication, however, dates the origin of those mixed feelings of admiration and repugnance which Bentley through his whole career continued to excite among his contemporaries.

In 1690 Bentley had taken deacon's orders in the Established Church. In 1692 he was nominated first Boyle lecturer, a nomination which was repeated in 1694. He was offered the appointment a third time in 1695, but declined it, being by that time involved in too many other undertakings. In these first series of lectures he endeavours to present the Newtonian physics in a popular form, and to frame them into a proof of the existence of an intelligent Creator. The second series, preached in 1694, has not been published, and is believed to be lost. Scarcely was Bentley in priest's orders before he was preferred to a prebendal stall in Worcester cathedral. And, in 1693, the keepership of the royal library becoming vacant by the death of Henri de Justel, great efforts were made by his friends to obtain the place for Bentley. But, though there was a High Church candidate (Edmund Gibson) backed by the archbishops, the court interest prevailed, and the place was given to Mr Thynne. Mr Thynne, however, wanted only the salary and not the office, and was prevailed on to cede the place to Bentley for an annuity of £130 for life, the whole emoluments being but £200 and apartments in St James's Palace. To these preferments were added, in 1695, a royal chaplaincy, and the living of Hartlebury. He was also about the same time elected a fellow of the Royal Society. And the recognition of Continental scholars came in the shape of a dedication, by Grævius (John George), prefixed to a dissertation of Albert Rubens, *De vita T. Maltii*, published at Utrecht in 1694.

While these distinctions were being accumulated upon Bentley, his energy was making itself felt in many and various directions. His first care was the royal library, the queen's library, as it was commonly called. He made great efforts to retrieve this collection from the dilapidated condition into which it had been allowed to fall. He employed the mediation of the earl of Marlborough to beg the grant of some additional rooms in the palace for the books. The rooms were granted, but Marlborough characteristically kept them for himself. Bentley enforced the law against the publishers, and thus added to the library nearly 1000 volumes which had been neglected to be delivered. He was commissioned by the University of Cambridge to obtain Greek and Latin founts for their classical books, and he had accordingly cast, in Holland, those beautiful types which appear in the Cambridge books of that date. He assisted Evelyn in his *Nussumata*. All Bentley's literary appearances at this time were of this accidental character. We do not find him settling down to the steady execution of any of the great projects with which he had started. He designed, indeed, in 1694, an edition of Philostratus, but easily abandoned it to Olearius, "to the joy," says F. A. Wolf, "of Olearius and of no one else." He supplied Grævius with collations of Cicero, and Joshua Barnes with a warning as to the spuriousness of the *Epistles of Euripides*, which was thrown away upon that blunderer, who printed the epistles and declared that no one could doubt their genuineness but a man "perfectus

frontis aut judicii immaniti." Bentley supplied to Gravins's *Callimachus* a masterly collection of the fragments.

The *Dissertation on the Epistles of Phalaris*, the work on which Bentley's fame in great part rests, originated in the same casual way. Wotton being about to bring out a second edition of his book on *Ancient and Modern Learning*, claimed of Bentley the fulfilment of an old promise to write a paper exposing the spuriousness of the *Epistles of Phalaris*. This paper was resented as an insult by the Christchurch editor of *Phalaris*, Hon. Charles Boyle, afterwards earl of Orrery. Assisted by his college friends, Boyle wrote a reply, "a tissue," says Mr Dyce, "of superficial learning, ingenious sophistry, dexterous malice, and happy railery." The reply was hailed by the public as crushing, and went immediately into a second edition. It was incumbent on Bentley to rejoice. This he did, in what Porson styles "that immortal dissertation," to which no answer was, or could be, given.

In the year 1700, Bentley, then in his 38th year, received that main preferment which, says De Quincey, "was at once his reward and his scourge for the rest of his life." The six commissioners of ecclesiastical patronage unanimously recommended Bentley to the Crown for the headship of Trinity College.

Trinity College, the most splendid foundation in the University of Cambridge, and in the scientific and literary reputation of its fellows the most eminent society in either university, had, in 1700, greatly fallen from its high estate. It was not that it was more degraded than the other colleges, but its former lustre made the abuse of endowments in its case more conspicuous. The eclipses had taken place during the reaction which followed 1660, and was owing to causes which were not peculiar to Trinity, but which influenced the nation at large. The names of Pearson and Barrow, and, greater than either, that of Newton, adorn the college annals of this period. But these were quite exceptional men. They had not inspired the rank and file of fellows of Trinity with any of their own love for learning or science. Indolent and easy-going clerics, without duties, without a pursuit, or any consciousness of the obligation of endowments, they haunted the college for the pleasant life and the good things they found there, creating sinecure offices in each other's favour, jobbing the scholarships, and making the audits mutually pleasant. Any excuse served for a banquet at the cost of "the house," and the celibate imposed by the statutes was made as tolerable as the decorum of a respectable position permitted. To such a society Bentley came, obnoxious as a Johnian and an intruder, unwelcome as a man of learning, whose interests lay outside the walls of the college. Bentley replied to their concealed dislike with open contempt, and proceeded to ride roughshod over their little arrangements. He inaugurated many beneficial reforms in college usages and discipline, executed extensive improvements in the buildings, and generally used his eminent station for the promotion of the interests of learning, both in the college and in the university. But this noble energy was attended by a domineering temper, an overweening contempt for the feelings, and even for the rights, of others, and an unscrupulous use of means when a good end could be obtained. Bentley, at the summit of classical learning, disdained to associate with men whom he regarded as illiterate priests. He treated them with contumely, while he was diverting their income to public purposes. The continued drain upon their purses—on one occasion the whole dividend of the year was absorbed by the rebuilding of the chapel—was the grievance which at last roused the fellows to make a resolute stand. After ten years of stubborn, but ineffectual resistance within the college, they had recourse, in 1710, to the last remedy—an

appeal to the visitor. Their petition is an ill-drawn invective, full of general complaints, and not alleging any special delinquency. Bentley's reply (*The Present State of Trinity College, &c.*, 8vo, Lond. 1710) is in his most crushing style. The fellows amended their position, and put in a fresh charge, in which they articulated fifty-four separate breaches of the statutes as having been committed by the master. Bentley, called upon to answer, demurred to the bishop of Ely's jurisdiction, alleging that the Crown was visitor. He backed his application by a dedication of his *Horace* to the lord treasurer (Harley). The Crown lawyers decided the point against him; the case was heard, and a sentence of ejection from the mastership ordered to be drawn up, but before it was executed the bishop of Ely died, and the process lapsed.

This process, though it had lasted nearly five years, was only a prologue to the great feud, the whole duration of which was twenty-nine years. Space will not allow of its vicissitudes being here followed. It must suffice to say that Bentley was sentenced by the bishop of Ely (Greene) to be ejected from the mastership, and by Convocation to be stripped of his degrees, and that he foiled both the visitor and the university.

Bentley survived the extinction of this thirty years' war, two years. Surrounded by his grandchildren, he experienced the joint pressure of age and infirmity as lightly as is consistent with the lot of humanity. He continued to amuse himself with reading; and though nearly confined to his arm-chair, was able to enjoy the society of his friends, and several rising scholars, Maitland, John Taylor, his nephews Richard and Thomas Bentley, with whom he discussed classical subjects. He was accustomed to say that he should live to be 80, adding that a life of that duration was long enough to read everything worth reading. He fulfilled his own prediction, dying, of a pleurisy, 14th July 1742, when he was a few months over 80. Though accused by his enemies of being grasping, he left not more than £5000 behind him. A few Greek MSS., brought from Mount Athos, he left to the college library; his books and papers to his nephew, Richard Bentley. Richard, who was a fellow of Trinity, at his death in 1786, left the papers to the college library. The books were acquired by purchase, by the British Museum.

Of his personal habits some anecdotes are related by his grandson, Richard Cumberland, in vol. i. of his *Memoirs* (Lond. 1807). The hat of formidable dimensions, which he always wore during reading to shade his eyes, and his preference of port to claret, are traits embodied in Pope's caricature (*Dunciad*, b. 4), which bears in other respects little resemblance to the original. He did not take up the habit of smoking till he was 70. He held the archdeaconry of Ely with two livings, but never obtained higher preference in the church. He was offered the (then poor) bishopric of Bristol, but refused it, and being asked what preferment he would consider worth his acceptance, replied, "That which would leave him no reason to wish for a removal."

Dr Bentley married, in 1701, Joanna, daughter of Sir John Bernard of Brompton. Their union lasted forty years. Mrs Bentley died in 1740, leaving a son, Richard, and two daughters, one of whom married, in 1728, Mr Denison Cumberland, grandson of Richard Cumberland, bishop of Peterborough, and father of Richard Cumberland the dramatic author.

The *Life of Richard Bentley*, by Bishop Monk (4to, Lond. 1830; 2d ed., 2 vols. 8vo, 1833), gives in full detail an interesting account of the Trinity College feud, and the other incidents of his hero's life. But, though himself a Greek scholar of celebrity and an editor of Euripides, Dr Monk appears to have had but an imperfect compre-

hension of the consummate genius and vast acquirements of the subject of his biography. He regrets that Bentley wasted his time upon conjectural criticism, instead of applying himself to the deistical controversy. The *Remarks upon a late Discourse of Freethinking*, by Philoleutherus Lipsiensis, 8vo, 1713, to which Dr Monk alludes, is indeed a very characteristic piece of writing; but it gives no more idea of what Bentley was as a master of ancient learning than does his pamphlet, *The Present State of Trinity College*, quoted before. Indeed, of all Bentley's publications there is not one which can be taken as an adequate sample of the critic, as a work at once monumental and characteristic. Bentley is most imperfectly represented by any one of his books. They have all the same occasional stamp. This is the case not only with the most popular of these, the *Dissertation on Phalaris*. The *Horatius* of 1712 was brought out to propitiate public opinion at a critical period of the struggle with the fellows of Trinity; the proposals for a recension of the New Testament text, 1720, had a similar origin; the *Terentius* of 1725 was occasioned by his resentment of Hare's conduct. The *Milton* was undertaken at the request of Queen Caroline, but also at an anxious conjuncture of the great quarrel. Nearly all his lesser performances were called forth by friends invoking his aid for their own schemes. What he wrote, he wrote with rapidity, rather with precipitation. If we try to form our idea of the man, not from this or that extempore effusion, but from all that he did or was, we shall find that Bentley was the first, perhaps the only Englishman who can be ranked with the great heroes of classical learning. Before him we have only Selden to name, or, in a more restricted field, Gataker and Pearson. But Selden, with stupendous learning, wanted that which Bentley shared with Scaliger or Wolf, the freshness of original genius and confident mastery over the whole region of his knowledge. "Bentley is not," says Mähly, "one among the great classical scholars, but he inaugurates a new era of the art of criticism. He opened a new path. With him criticism attained its majority. When scholars had hitherto offered suggestions and conjectures, Bentley, with unlimited control over the whole material of learning, gave decisions." The modern German school of philology, usually so unjust to foreigners, yet does ungrudging homage to the genius of this one Englishman. Bentley, says Bunsen, "was the founder of historical philology." And Bernays says of his corrections of the *Tristia*, "corruptions which had hitherto defied every attempt even of the mightiest, were removed by a touch of the fingers of this British Samson." The English school of Hellenists, by which the 18th century was distinguished, and which contains the names of Dawes, Markland, Taylor, Toup, Tyrwhitt, Porson, Dobree, Kidd, and Monk, was the creation of Bentley. And even the Dutch school of the same period, though the outcome of a native tradition, was in no small degree stimulated and directed by Bentley's example. Ruhken has recorded the powerful effect produced upon the young Hemsterhuys by Bentley's letter to him on the occasion of his *Pollux*; at first humiliated to despair by the revelation to him of his own ignorance; then stimulated to higher effort by the consideration that commendation from such a man was not words of mere compliment.

Bentley was a source of inspiration to a following generation of scholars. Himself, he sprang from the earth without forerunners, without antecedents. Self-taught, he created his own science. It was his misfortune that there was no contemporary guild of learning in England by which his power could be measured, and his eccentricities checked. In the *Phalaris* controversy his academical adversaries had not sufficient knowledge to know how absolute their defeat was. Garth's couplet—

"So diamonds take a lustre from their fall,  
And to a Bentley 'tis we owe a Boyle"—

expressed the belief of the wits, or literary world, of the time. It was not only that he had to live with inferior, and to waste his energy in a struggle forced upon him by the necessities of his official position, but the wholesome stimulus of competition and the encouragement of a sympathetic circle were wanting. In a university where the instruction of youth, or the religious controversy of the day, were the only known occupations, Bentley was an isolated phenomenon, and we can hardly wonder that he should have flagged in his literary exertions after his appointment to the mastership of Trinity. All his vast acquisitions and all his original views seem to have been obtained before 1700. After this period he acquired little, and made only spasmodic efforts—the *Horace*, the *Terence*, and the *Milton*. The prolonged mental concentration, and mature meditation, of which alone a great work can be born, were wanting to him.

BIBLIOGRAPHY.—1. *Epistola ad Millium*, at end of *Mahle Chronicon*, Oxon. 1691; 2d ed., 1718. 2. *The Folly and Unreasonableness of Atheism*, 4to, Lond. 1693 (1st Boyle Lecture). 3. *Dissertation on Phalaris*, &c., at end of Wotton's *Reflections*, &c., 8vo, Lond. 1697; 2d ed., much enlarged, 1699; 3d ed., Lond. 1777; reprinted, 12mo, Berlin, 1875; Latin translation by Lemp, 4to, Groningen, 1777. 4. *Horatius*, 4to, Cantab. 1711. 5. *Remarks on a late Discourse of Freethinking*, by Philoleutherus Lipsiensis, 8vo, Lond. 1712; 8th ed., Camb. 1743; translated into French by Armand de la Chapelle, Amst. 1788. 6. *Emendationes in Memoriam Philomonis Belgicæ*, 8vo, Cantab. 1713. 7. *Proposals for a new edition of the Greek Testament*, 4to, Lond. 1721. 8. *Terentius*, 4to, Cantab. 1725. 9. *Milton's Paradise Lost*, 4to, Lond. 1732. 10. *Monitium Astronomicum*, 4to, Lond. 1738. 11. *Critica Sacra; Notes on the Greek and Latin Text of the New Testament*, ed. by A. A. Ellis, 8vo, Camb. 1862.

*The Works of Richard Bentley, D.D.*, collected and edited by the Rev. Alexander Dyce, 3 vols. 8vo, Lond. 1836. These volumes contain the *Dissertation on Phalaris*, in its enlarged and in its original form as it was appended to Wotton's *Reflections*, 1696; the *Boyle Lectures* of 1692; *Remarks upon a Discourse of Freethinking*, 1718; *Proposals for printing a new edition of the Greek Testament*, 1721; *Epistola ad Millium*, 1691; and some smaller pieces. *Bentley at Doctorum Virorum ad eum Epistolæ*, 4to, Lond. 1807; 2d ed., enlarged, 8vo, Lips. 1825. *Correspondence*, 3 vols. 8vo, Lond. 1842. *Monk's Life of Bentley*, 4to, Lond. 1850; 2d ed., 3 vols. 8vo., Lond. 1853. *Richard Bentley, Eine Biographie, von Jacob Mähly*, 8vo, Leipz. 1868. (M. P.)

**BENZOIC ACID**, an organic acid present in large quantity in gum benzoin, and found also in dragon's blood (the resin of *Calamus Draco*) and some allied substances. It is, besides, prepared by numerous reactions from organic substances, being now largely made from naphthalin, one of the products of the distillation of coal tar. Benzoic acid is extracted from gum benzoin by the process of sublimation. The resin, coarsely powdered, is submitted to a heat of 300° Fahr. in a close vessel, by which the acid is expelled and may be condensed in receivers. By the sublimation process the acid carries away with it a small portion of essential oil, which gives its peculiar sweet odour to sublimed benzoic acid. It may also be separated from gum benzoin by boiling the powdered gum in lime, filtering off the compound of resin and lime, and concentrating the remaining solution of benzoate of calcium, from which benzoic acid is precipitated by hydrochloric acid. The benzoic acid may then be purified by sublimation, but thus prepared it is destitute of odour. It crystallises into beautiful white silky flexible needles, and yields on heating an acrid, irritating vapour which excites coughing. It is distinguished from the closely allied substance, cinnamic acid, by withstanding the action of boiling dilute nitric acid, which changes the other into bitter almond oil, the hydride of benzoyl. Benzoic acid is rarely employed in medicine alone, but in composition as benzoate of ammonia it acts as a stimulant of mucous membranes, and is occasionally given in chronic bronchial affections. It is an

ingredient in some official tinctures, such as the compound tincture of camphor, and ammoniated tincture of opium.

**BENZOIN, GUM**, sometimes called **GUM BENJAMIN**, a fragrant gum-resin obtained from *Styrax Benzoin*, a tree of considerable size, a native of Sumatra and Java, and introduced into Siam, Borneo, &c. The gum-resin is obtained by making incisions in the bark of trees after they have attained six years of age, when the benzoin exudes, and after hardening in the air is carefully scraped off with a knife. A tree produces on an average about 3 lb annually for 10 or 12 years. The produce of the first three years is known as "head" benzoin, and is esteemed the finest and most valuable; that produced in later years goes by the name of "belly" benzoin; and after the trees are cut down a small quantity of a dark-coloured and very inferior quality is obtained, which is called "foot" benzoin. In commerce the gum-resin is distinguished as Siam or Sumatra benzoin, according to the localities from which it is derived. Siam benzoin is generally regarded as the best, and of it two varieties are distinguished. The finest quality is Siam benzoin "in tear," it being in small flattened drops, from the size of an almond kernel downwards. "Lump" Siam benzoin consists of agglutinated masses of such tears, or of tears imbedded in a darker coloured resinous matrix. Tear benzoin varies in colour from a pale yellow to a reddish-brown colour, and lump benzoin has a conglomerate-like structure from the dissemination of almond-shaped tears throughout the substance. Sumatra benzoin has neither so strong nor so agreeable an odour as that of Siam, but the finest qualities are not found in the English market, being bought up for use in the religious rites of the Greek Church in Russia. Sumatra benzoin occurs in larger rectangular masses of a greyish tint, with few large tears in it, but containing small white opaque pieces, with chips of wood and other impurities, in a translucent matrix. Benzoin is composed of a mixture of three resins, distinguished by their behaviour towards solvents, and of benzoic acid, with sometimes cinnamic acid in addition; in some specimens of Sumatra benzoin cinnamic acid has been found entirely replacing benzoic acid. Usually benzoin contains from 12 to 18 per cent. of benzoic acid, the opaque white portions containing less than the brown resinous substance. It also contains traces of a highly odorous essential oil, like styrol, the aromatic oil present in storax. The quantity of benzoin exported from Sumatra in 1871 was about 16,000 cwt., while Siam sent out only 405 cwt., but very great quantities are used as incense in the religious ceremonies of the East, which indeed is the principal object for which it is brought into the commerce of Western nations. In medicine benzoin is seldom administered except as an adjunct to pectoral medicines. A compound tincture of benzoin is applied to flabby ulcers, and to excised wounds after the edges have been brought together. In these connections benzoin has a popular reputation under the name of Friars' or Monks' Balsam, which is a compound tincture of benzoin, and it forms an ingredient in ointment or black sticking-plaster. Benzoin diminishes the tendency towards rancidity in fats, a circumstance turned to account in the *Adeps benzoatus* of pharmacy.

**BÉRANGER, PIERRE JEAN DE**, the national song-writer of France, was born at Paris on the 19th August 1780. The aristocratic particle before the name was a piece of groundless vanity on the part of his father, which the poet found useful as a distinction. He was descended, in truth, from a country innkeeper on the one side, and, on the other, from a tailor in the Rue Montorgueil. Of education, in the narrower sense, he had but little. From the roof of his first school he beheld the capture of the Bastille, and this stirring memory was all that he acquired.

Later on he passed some time in a school at Péronne, founded by one Bellenglise on the principles of Rousseau, where the boys were formed into clubs and regiments, and taught to play solemnly at politics and war. Béranger was president of the club, made speeches before such members of Convention as passed through Péronne, and drew up addresses to Tallien or Robespierre at Paris. In the meanwhile he learned neither Greek nor Latin—not even French, it would appear; for it was after he left school, from the printer Laisney, that he acquired the elements of grammar. His true education was of another sort. In his childhood, shy, sickly, and skilful with his hands, as he sat at home alone to carve cherry stones, he was already forming for himself those habits of retirement and patient elaboration which influenced the whole tenor of his life and the character of all that he wrote. At Péronne he learned of his good aunt to be a stout republican; and from the doorstep of her inn, on quiet evenings, he would listen to the thunder of the guns before Valenciennes, and fortify himself in his passionate love of France and distaste for all things foreign. Although he could never read Horace save in a translation, he had been educated on *Talesnagus*, Racine, and the dramas of Voltaire, and taught, from a child, in the tradition of all that is highest and most correct in French.

After serving his aunt for some time in the capacity of waiter, and passing some time also in the printing office of one Laisney, he was taken to Paris by his father. Here he saw much low speculation and many low royalist intrigues. In 1802, in consequence of a distressing quarrel, he left his father and began life for himself in the garret of his ever memorable song. For two years he did literary hackwork, when he could get it, and wrote pastorals, epics, and all manner of ambitious failures. At the end of that period (1804) he wrote to Lucien Bonaparte, enclosing some of these attempts. He was then in bad health, and in the last stage of misery. His watch was pledged. His wardrobe consisted of one pair of boots, one greatcoat, one pair of trousers with a hole in the knee, and "three bad shirts which a friendly hand wearied itself in endeavouring to mend." The friendly hand was that of Judith Frère, with whom he had been already more or less acquainted since 1796, and who continued to be his faithful companion until her death, three months before his own, in 1857. She must not be confounded with the *Lisette* of the songs; the pieces addressed to her (*La Bonne Vieille*, *Maudit Printemps*, &c.) are in a very different vein. Lucien Bonaparte interested himself in the young poet, transferred to him his own pension of 1000 francs from the Institute, and set him to work on a *Death of Nero*. Five years later, through the same patronage, although indirectly, Béranger became a clerk in the university at a salary of another thousand.

Meanwhile he had written many songs for convivial occasions, and "to console himself under all misfortunes;" some, according to M. Boiteau, had been already published by his father; but he set no great store on them himself; and it was only in 1812, while watching by the sick-bed of a friend, that it occurred to him to write down the best he could remember. Next year he was elected to the *Casseau Moderne*, and his reputation as a song-writer began to spread. Manuscript copies of *Les Gueux*, *La Sénatour*, above all of *Le Roi d'Yvetot*, a satire against Napoleon, whom he was to magnify so much in the sequel, passed from hand to hand with acclamation. It was thus that all his best works went abroad; one man sang them to another over all the land of France. He was the only poet of modern times who could altogether have dispensed with printing.

His first collection escaped censure, "We must pardon

many things to the author of the *Bot d'Yvetot*," said Louis XVIII. The second (1821) was more daring. The apathy of the Liberal camp, he says, had convinced him of the need for some bogle call of awakening. This publication lost him his situation in the university, and subjected him to a trial, a fine of 500 francs, and an imprisonment of three months. Imprisonment was a small affair for Béranger. At Sainte Pélagie he occupied a room (it had just been quitted by Paul Louis Courier), warm, well-furnished, and preferable in every way to his own poor lodging, where the water froze on winter nights. He adds, on the occasion of his second imprisonment, that he found a certain charm in this quiet, claustral existence, with its regular hours and long evenings alone over the fire. This second imprisonment of nine months, together with a fine and expenses amounting to 1100 francs, followed on the appearance of his fourth collection. The Government proposed through Lafitte that, if he would submit to judgment without appearing or making defences, he should only be condemned in the smallest penalty. But his public spirit made him refuse the proposal; and he would not even ask permission to pass his term of imprisonment in a *Maison de Santé*, although his health was more than usually feeble at the time. "When you have taken your stand in a contest with Government, it seems to me," he wrote, "ridiculous to complain of the blows it inflicts on you, and impolitic to furnish it with any occasion of generosity." His first thought in La Force was to alleviate the condition of the other prisoners.

In the revolution of July he took no inconsiderable part. Copies of his song, *Le Vieux Drapeau*, were served out to the insurgent crowd. He had been for long the intimate friend and adviser of the leading men; and during the decisive week his counsels went a good way towards shaping the ultimate result. "As for the republic, that dream of my whole life," he wrote in 1831, "I did not wish it should be given to as a second time unripe." Louis Philippe, hearing how much the songwriter had done towards his elevation, expressed a wish to see and speak with him; but Béranger refused to present himself at court, and used his favour only to ask a place for a friend, and a pension for Rouget de l'Isle, author of the famous *Marseillaise*, who was now old and poor, and whom he had been already succouring for five years.

In 1848, in spite of every possible expression of his reluctance, he was elected to the assembly, and that by so large a number of votes (4471) that he felt himself obliged to accept the office. Not long afterwards, and with great difficulty, he obtained leave to resign. This was the last public event of Béranger's life. He continued to polish his songs in retirement, visited by nearly all the famous men of France. He numbered among his friends Chateaubriand, Thiers, Laffitte, Michelet, Lamennais, Mignet. Nothing could exceed the amiability of his private character; so poor a man has rarely been so rich in good actions; he was always ready to receive help from his friends when he was in need, and always forward to help others. His correspondence is full of wisdom and kindness, with a smack of Montaigne, and now and then a vein of pleasantry that will remind the English reader of Charles Lamb. He occupied some of his leisure in preparing his own memoirs, and a certain treatise on *Social and Political Morality*, intended for the people, a work he had much at heart, but judged at last to be beyond his strength. He died on the 16th July 1857. It was feared that his funeral would be the signal for some political disturbance; but the Government took immediate measures, and all went quietly. The streets of Paris were lined with soldiers and full of townfolk, silent and uncovered. From time to time cries arose:—"Honneur, Honneur à Béranger!"

The songs of Béranger would scarcely be called songs in England. They are elaborate, written in a clear and sparkling style, full of wit and incision. It is not so much for any lyrical flow as for the happy turn of the phrase that they claim superiority. Whether the subject be gay or serious, light or passionate, the medium remains untroubled. The special merits of the songs are merits to be looked for rather in English prose than in English verse. He worked deliberately, never wrote more than fifteen songs a year and often less, and was so fastidious that he has not preserved a quarter of what he finished. "I am a good little bit of a poet," he says himself, "clever in the craft, and a conscientious worker, to whom old airs and a modest choice of subjects (*Le coin ou je me suis couché*), have brought some success." Nevertheless, he makes a figure of importance in literary history. When he first began to cultivate the *chanson*, this minor form lay under some contempt, and was restricted to slight subjects and a humorous guise of treatment. Gradually he filled these little chiseled toys of verbal perfection with ever more and more of sentiment. From a date comparatively early he had determined to sing for the people. It was for this reason that he fled, as far as possible, the houses of his industrial friends, and came back gladly to the garret and the street corner. Thus it was, also, that he came to acknowledge obligations to *ami Debraux*, who had often stood between him and the masses as interpreter, and given him the key-note of the popular humour. Now, he had observed in the songs of sailors, and all who labour, a prevailing tone of sadness; and so, as he grew more masterful in this sort of expression, he sought more and more after what is deep, serious, and constant in the thoughts of common men. The evolution was slow; and we can see in his own works examples of every stage, from that of witty indifference in fifty pieces of the first collection, to that of grave and even tragic feeling in *Les Souvenirs du Peuple* or *Le Vieux Fagotier*. And this innovation involved another, which was as a sort of prelude to the great romantic movement. For the *chanson*, as he says himself, opened up to him a path in which his genius could develop itself at ease; he escaped, by this literary postern, from strict academical requirements, and had at his disposal the whole dictionary, four-fifths of which, according to La Harpe, were forbidden to the use of more regular and pretentious poetry. If he still kept some of the old vocabulary, some of the old imagery, he was yet accustoming people to hear moving subjects treated in a manner more free and simple than hitherto; so that his was a sort of conservative reform, preceding the violent revolution of Victor Hugo and his army of uncompromising romantics. He seems himself to have had glimmerings of some such idea; but he withheld his full approval from the new movement on two grounds:—first, because the romantic school missed somewhat brutally the delicate organism of the French language; and second, as he wrote to Sainte-Beuve in 1832, because they adopted the motto of "Art for art," and set no object of public usefulness before them as they wrote. For himself (and this is the third point of importance) he had a strong sense of political responsibility. Public interest took a far higher place in his estimation than any private passion or favour. He had little tolerance for those erotic poets who sing their own loves and not the common sorrows of mankind, "who forget," to quote his own words, "forget beside their mistresses those who labour before the Lord." Hence it is that so many of his pieces are political, and so many, in the later times at least, inspired with a socialistic spirit of indignation and revolt. It is by this socialism that he becomes truly modern, and touches hands with Burns.

The following books may be consulted:—*Ma Biographie* (his own memoirs); *Vie de Béranger*, by Paul Boiteau, 1861; *Correspondances de Béranger*, edited by Paul Boiteau, 4 vols. 1860; *Béranger et Lamennais* (by Napoléon Peyrat), 1857; *Quarante-Cinq lettres de Béranger publiées par Madame Louise Collet* (almost worthless), 1857; *Béranger, ses amis, ses ennemis, et ses critiques*, by A. Arnould, 3 vols., 1864; J. Janin, *Béranger et son Temps*, 2 vols., 1866; also Sainte-Beuve's *Portraits Contemporains*, vol. 1. (R. L. S.)

BERAR, a province of British India, forming a Commissionership, is situated between 19° 30' and 21° 45' N. lat., and 76° and 79° 15' E. long. Area, about 17,500 square miles; population, 2½ millions. The province consists of the districts assigned to the British Government by his Highness the Nizam of Hyderabad, under the treaties of 1853 and 1861. These districts are Amrâotî, Elichpur, Wîn, Akolâ, Baldânâ, and Bâsim. Berar province is bounded on the N. and E. by the Central Provinces, on the S. by the Nizam's dominions, and on the W. by the Nizam's territory, the Bombay district of Khandesh, and by the Central Provinces. The Ajantâ range intersects the whole province from W. to E., and divides it into two distinct sections—the Payanghât or lowland country, bounded on the N. by

the Gáwilarh range of the Sápura hills, which form the northern boundary between Berar and the Central Provinces, and on the S. by the Ajantá range, and the Bálághát or upland country of the Ajantá hills, occupying the whole southern part of the province. The Payanghát is a wide valley running up eastward between the Ajantá range and the Gáwilarh hills, from 40 to 50 miles in breadth. This tract contains all the best land in Berar, it is full of deep, rich, black alluvial soil, called *regár*, of almost inexhaustible fertility, and it undulates just enough to maintain a natural system of drainage. Here and there are barren tracts where the hills jut out far into the plain, covered with stones and scrub jungle, or where a few isolated flat-topped hills occur. There is nothing picturesque about this broad strip of alluvial country, it is destitute of trees except near the villages close under the hills; and apart from the Púrná, which intersects it from east to west, it has hardly a perennial stream. In the early autumn it is one sheet of cultivation, but after the beginning of the hot season, when the crops have been gathered, its monotonous plain is relieved by neither verdure, shade, nor water. The aspect of the country above the passes which lead to the Bálághát is quite different. The trees are finer and the groves more frequent than in the valley below; water is more plentiful and nearer to the surface. The highlands fall southwards towards the Nizám's country by a gradual series of ridges or steppes. The principal rivers of the province are the Taptá, which forms a portion of its north-western boundary; the Púrná, which intersects the valley of the Payanghát; the Wardhá, forming the whole western boundary line; and the Páin-gangá, marking the southern boundary for nearly its whole distance. The only natural lake is the Salt Lake of Sunár. There are no large tanks or artificial reservoirs.

The total area of the province in 1869-70 was returned at between 17,000 and 18,000 square miles, of which about one-half is cultivated, one-fourth cultivable but not cultivated, and the remaining one-fourth uncultivable waste. The great crops are cotton of a superior quality, and *jodr* or millet. The acreage under the different crops in 1869-70 is thus returned—*Jodr*, 1,812,693 acres; cotton, 1,408,430; wheat, 478,488; pulses, 498,000; *bafrá*, 117,278; rice, 44,798; linseed, 61,894; hemp, 8978; *kará*, 57,192; tobacco, 32,384; castor oil, 2605; sugar cane, 7947; opium, 247; other crops, 829,992; total, 8,266,276 acres, or 8369 square miles. The uncultivated products consist of dyes, gums, fruits and roots of various trees and creepers, honey and beeswax, and jungle fibres. The land settlement of the province is now being made for a period of thirty years, based upon the Bombay system of survey and settlement according to fields. Manufactures are very few, and consist principally of cotton cloth, mostly of coarse quality, stout carpets, saddlery, and a little silk weaving. In 1869-70 the total value of the imports was returned at £7,350,085, and the exports at £5,755,390. For internal communication six first-class roads have been constructed out of the general revenues of the province:—(1). From Amrótí to Elíchpur, 31 miles; (2). from Badnerá to Mardá, 38; (3). from Karinjá to Murtisápur, 21; (4). from Badnerá to Amrótí, 6; (5). from Akolá to Bámín, 50; (6). from Akolá to Akot, 21 miles. The Nágpur branch of the Great Indian Peninsular Railway traverses the province from east to west for about 150 miles, with short off-shoots to the great cotton marts of Khamgion and Amrótí.

The census of 1867 returned the total population of Berar province at 2,231,566 souls, dwelling in 495,760 houses, comprising 5694 towns and villages; average density of population, 128 per square mile; average number of persons per house, 4.5; proportion of males in total population, 51.7 per cent. Classified according to religion, the Hindus number 1,912,661, or 85.7 per cent. of the total population; Mahometans, 154,951, or 6.94 per cent.; aborigines, 163,059, or 7.36 per cent.; Christians, 903; Parsís, 75; and Jews, 16. The Mahometan population of the province is descended from the men who originally accompanied from the north the Muzahmán invaders of the Deccan. Among the aboriginal tribes, the most numerous are the Gonds, Ands, Korkus, Kolis, and Káláns. The principal towns in the province are—(1.) Elíchpur, the capital of the old kingdom, and still the most populous town, although not a place of any commercial importance, population 27,783; (2.) Amrótí, the richest town in the province, and a rising and flourishing seat of commerce, pop. 23,416; (3.) Akolá,

pop. 12,286; (4.) Akot, a large cotton mart, pop. 14,906; (5.) Karinjá, pop. 11,750; (6.) Khamgion, a large and prosperous cotton mart, pop. 9482.

The total imperial revenue of Berar province in 1869-70 amounted to £764,109, of which the land revenue gave 4487,343; excise, £114,513; salt wells, 2650; miscellaneous, 239,413; stamps, £45,947; forests, £18,462; and customs (salt), £37,780. Local funds and cesses amounted to £122,229, or a total revenue from imperial and local sources for the province of £886,338. For the protection of person and property Berar province contains 67 police stations, with 61 outposts—total strength of regular police, 2613 of all ranks, exclusive of the village watch. The only troops located in the province are those of the Haidarábád contingent. At Elíchpur a regiment of infantry with a detachment of cavalry and a battery of artillery is stationed; infantry detachments are also stationed at Amrótí and Akolá. The provision for education consisted in March 1870 of 341 schools, attended by 14,898 pupils. Of these 2 are high schools, one at Akolá and one at Amrótí, with 217 pupils; 44 middle-class schools with 3747 pupils; 267 primary schools with 10,148 pupils; 27 female schools with 730 pupils; and 1 Normal school for the training of masters.

The climate of Berar differs very little from that of the Deccan generally, except that in the Payanghát valley the hot weather is exceptionally severe. Here the freshness of the cold season vanishes after the crops have been taken off the ground, but the heat does not very sensibly increase until the end of March. From May 1st, until about the middle of June when the rains set in, the sun is very powerful, but without the scorching winds of upper India. The nights are comparatively cool. During the rains the air is moist and cool. In the Bálághát country above the Ajantá hills the thermometer always stands much lower than in the valley. The average rainfall for the whole province is said to be about 27 inches in the valley, and above 80 inches in the Bálághát highlands. In 1869 the rainfall registered in each of the six districts averaged 33 inches for the whole province. The average mean temperature registered at Akolá in the same year was nearly 81° Fahr.

The early history of Berar belongs to that of the Deccan. The province suffered repeated invasions of Mahometans from the north, and on the collapse of the Báhmani dynasty in 1526, Berar formed one of the five kingdoms under independent Mahometan princes, into which the Deccan split up. In the beginning of the seventeenth century the province was invaded by Prince Murád Mirza, son of the Emperor Akbar, and annexed to the Dehli empire. It did not long enjoy the blessings of tranquillity, for on the rise of the Marhattá power about 1650, the province became a favourite field of plunder. In 1671 the Marhattá general, Pratáp Ráo, extended his ravages as far east as Karinjá, and exacted from the village officers a pledge to pay *chauth*. In 1704 things had reached their worst; the Marhattás swarmed through Berar "like ants or locusts," and laid bare whole districts. They were expelled in 1704 by Zulfikár Khan, one of Aurangzeb's best generals, but they returned incessantly, levying black-mail in the shape of *chauth* and *sardeshmukhí*, with the alternative of fire and sword. Upon the death of Aurangzeb the Marhattás consolidated their predominance in Berar, and in 1817 their demand for *chauth*, or a fourth, and *sardeshmukhí*, or a tenth of the revenue of the province, was conceded by the governor. But in 1720-24 the viceroy of the Deccan, under the title of Nizám-ul-mulk, gained his independence by a series of victories over the imperial generals, and from that time till its cession to England in 1853, Berar was always nominally subject to the Haidarábád dynasty. The Marhattá rulers posted their officers all over the province, they occupied it with their troops, they collected more than half the revenue, and they fought among themselves for possession of the right to collect; but, with the exception of a few *parganás* ceded to the Peshwá, the Nizám maintained his title as *de jure* sovereign of the country, and it was always admitted by the Marhattás. In the Marhattá war of 1803, the British under General Wellesley, afterwards the duke of Wellington, assisted by the Nizám, crushed the Marhattá power in this part of the country, by utterly defeating them at Argáon on the 28th November 1803, and a few days afterwards at Gáwilarh. On the 19th December

1803 the Marhattá chief signed a treaty, in which he resigned all claim to territory and revenue west of the Wardhá, but retained Narnálá and Gáwilgarh in his possession. By this treaty the whole of Berar was made over in perpetual sovereignty to the Nizám. From that time till 1848 the history of the province consists of a long list of internal dissensions and civil wars. These troubles reduced the state to the verge of bankruptcy. The pay of the Nizám's irregular force, maintained under the treaty of 1800, fell into arrears, and had to be advanced by the British Government. There were also other unsatisfied claims of the Government on the Nizám, and in 1853 his whole debt amounted to £450,000. Accordingly, in that year a new treaty was concluded with the Nizám, under which the existing Haidarábád contingent force is maintained by the British Government, in lieu of the troops which the Nizám had been previously bound to furnish on demand in time of war; while for the payment of this contingent and other claims on the Nizám, districts then yielding a gross revenue of £500,000 per annum, including the present province of Berar, were assigned to our Government. By this treaty his highness was released from the obligation of furnishing a large force in time of war; the contingent ceased to be a part of the Nizám's army, and became an auxiliary force kept up by the British Government for the Nizám's use. The treaty was revised in 1860, and as a reward for services rendered by the Nizám in 1857, two of the districts formerly assigned to us were restored to him, and the territory of the Rájá of Surápur, which had been confiscated in consequence of the rebellion of the chief, was added to the Nizám's dominions.

**BÉRARD**, FRÉDÉRIC, a French physician and writer on psychology, was born at Montpellier in 1789. He was educated at the famous medical school of that town, and afterwards proceeded to Paris, where he was for some time employed in connection with the *Dictionnaire des Sciences Médicales*. He returned to his native city in 1816, and published a work upon the principles of the school of Montpellier. In 1825 he was called to a chair of medicine at Paris, which he held for three years, being then nominated professor of hygiene at Montpellier. His health gave way under his labours, and he died, in 1828, at the early age of 39. A posthumous work, *Esprit des Doctrines Médicales de Montpellier*, was printed in 1830. Bérard's most important production is his treatise, *Des Rapports du Physique et du Moral*. According to him, consciousness or internal perception reveals to us the existence of an immaterial thinking, feeling, and willing subject, the self or soul. Alongside of this there is the vital force, the nutritive power, which uses the physical frame as its organ. The soul and the principle of life are in constant reciprocal action, and the first owes to the second, not the formation of its faculties, but the conditions under which they are evolved. (See Damiron, *Phil. en France au XIX<sup>th</sup> Siècle*.)

**BERBER**, or EL-MONCHERY, a town of considerable size on the east bank of the Nile, some distance below the confluence of the Atbara, in about 18° N. lat. and 34° E. long. It is of importance as one of the main stations on the direct route from Khartoum to Cairo, and as the starting place of caravans for Suakin, on the eastern coast.

**BERBERA**, one of the most important seaports on the coast of the Somali country, in East Africa, 160 miles E.S.E. of Zeyla, and nearly opposite Aden, in 10° 26' N. lat. and about 45° 4' E. long. It seems at one time to have been a town of some size, as there are still remains of an aqueduct extending inland for several miles; but its permanent inhabitants have for a long period been very

few. From November to April, however, it becomes the general resort of from ten to twenty thousand persons from all the neighbouring countries. The Habr-anel-Somali, in whose district the town is situated, come down to the place in the beginning of October, with poles and mats and skins, and of these slight materials erect huts and warehouses, which are rented from them by the merchants, who begin to arrive as soon as the south-west monsoon changes into the north-east wind. The chief disadvantage of the locality is that water has to be brought a distance of several miles from the wells of Baraka. (See *J. R. G. Soc.*, 1849, p. 54, *et seq.*; Petermann's *Mittheil.* 1860, p. 427, and 1873, p. 40; *Bollet. d. Soc. Geogr. Ital.*, 1873.)

**BERBICE**, the eastern division of British Guiana. See **GUIANA**.

**BERCHEM**, or BERGHEM, NICHOLAS, an eminent painter, born at Haarlem in 1624. He received instruction from his father, and from the painters Van Goyen, Wils, and Weenix. His pictures, of which he produced an immense number, were in great demand, as were also his etchings and drawings. His landscapes are highly esteemed; and many of them have been finely engraved by John Vischer, an eminent artist in his own line. The distinguishing characteristics of Berchem's works are—breadth and just distribution of lights, grandeur of the masses of shadow, truth and simplicity of the figures, just gradation of distances, brilliancy and transparency of colouring, correctness of design, and elegance of composition. He died in 1683.

**BERCHTESGADEN**, or BERCHTOLSGADEN, a small town, beautifully situated on the south-eastern confines of Bavaria, and long celebrated for its extensive mines of rock-salt, which were worked as early as 1174. Fresh water is brought into the mine, and, acting upon the salt rock, becomes brine. It is then run off in pipes to a reservoir in the vicinity; whence, by two hydraulic machines, it is raised 1500 feet, and conducted to Traunstein and Rosenheim, about forty miles farther inland. The town contains three old churches, and some good houses. Its inhabitants, amounting to 1760, are principally employed in the mines and in the manufacture of salt, while others are engaged in making those toys and other small articles of wood, horn, and ivory, for which the place has long been famous. The vicinity comprehends the most picturesque portion of Bavaria. The district of Berchtesgaden was formerly an independent spiritual principality, founded in 1109, and secularized in 1803. The abbey is now a royal castle, and in the neighbourhood a hunting-lodge was built by King Max II. in 1852.

**BERDIANSK**, a seaport town of Russia, in the government of Taurida, situated on the north-west shore of the Sea of Azoff, near the entrance of the River Berdianka into the Berdianak Gulf, in 46° 45' N. lat. and 36° 47' E. long. Berdianak was founded in 1827, at the suggestion of Vorontzoff, and by the following year was a regular settlement, which in 1835 was recognized as a town, and raised in 1842 to be capital of a circle. In 1833 its population was 3200, which had, in spite of the damage done to the town in 1855 by the English fleet, increased in 1860 to 9762. At that time it possessed two Greek churches and one Lutheran, and a Jewish and a Karaité synagogue. Its secular buildings comprised a custom-house, a hospital, a public library, and a theatre. The principal industries of the place are the making of bricks and tiles, the boiling of tallow, and the manufacture of macaroni. As a port it is of great importance. The roads are protected from every wind, except the south, which occasions a heavy surf; but this disadvantage has been lessened by the formation of a mole in 1863. Another inconvenience of the situation, however, is the rapid filling up of the port, which renders necessary



the removal of the wharves from time to time nearer to the sea. The chief articles of export are wheat, barley, linseed, rapeseed, rye, and oats; and the imports include hardware, fruits, oil, and petroleum, the last-named being used for the lighting of the town. Large deposits of coal exist in the basin of the Asoff, and Berdiansk would afford the greatest facilities for its exportation. In the immediate neighbourhood are valuable salt-lagoons. Population in 1867, 12,223.

**BERDICHEFF**, a town of Russian-Poland, in the government of Kiass, 24 miles from Jitomir, on the Gnulopyat, and not far from the borders of Volhynia, to which it historically belongs. It consists of about a dozen main streets and a large number of cross lanes, by far the largest proportion of the houses being built of wood or brick. Besides the cathedral of the Assumption, finished in 1832, there are three or four other Greek churches, several synagogues, and places of worship for Roman Catholics and others, besides a Carmelite convent. The market, the exchange, the theatre, the Jewish almshouse, and the Elizabeth hospital, are among the most important secular buildings. A large number of schools are maintained. An extensive trade is carried on, both with the surrounding country and with Germany, in peltry, silk goods, iron and wooden wares, salt-fish, grain, cattle, and horses. Five great markets are held yearly, the most important being on 12th June and 15th August. Among numerous minor industries may be mentioned the manufacture of tobacco, soap, candles, oil, bricks, and leather. The population amounted in 1867 to 52,563, the Jews forming about 50,000 of the whole number.

Berdichoff is a place of some antiquity. In the treaty of demarcation between the Lithuanians and the Poles in 1546, it is assigned to the former. In the 16th century the Kievan waiwoie, Yanut Teeshkevitch, built a castle in the village; and in 1627 he founded a monastery for Carmelite monks, to which he shortly afterwards presented the castle. The monks built themselves a crypt, and, as Berdichoff was subject to the incursions of Cossacks and Tatars, surrounded their monastery with rampart and ditch. In 1647, however, it was taken and plundered by Chmelnetski, and the monks who had escaped did not return till 1663, and only obtained possession of their former property in 1717. In 1765 Stanislas Augustus, at the request of Prince Radsevil, allowed the city to hold ten yearly markets, and from that date its commercial prosperity began. In 1768 Casimir Pulavski, leader of the confederacy of Barr, fled, after the capture of that city, to Berdichoff, and there, with 700 men, maintained himself during a siege of 25 days. During the Polish domination, Berdichoff was in the Viatkian waiwoieship; after its annexation to Russia it was assigned to Jitomir and Volhynia; and in 1845 it was raised to be capital of a circle. In the beginning of the 18th century it had passed from the Teeshkevitch to the Zevpah family, and from them was transferred by a marriage settlement to the Radsevil.

**BERENGARIUS**, a celebrated mediæval theologian, was born at Tours, 998 A.D. He was educated in the famous school of Fulbert of Chartres, and early acquired a great reputation for learning, ability, and piety. Appointed in 1031 superintendent of the cathedral school of his native city, he taught with such success as to attract pupils from all parts of France, and powerfully contributed to diffuse an interest in the study of logic and metaphysics, and to introduce that dialectic development of theology which is designated the scholastic. The earliest of his writings of which we have any record is an *Exhortatory Discourse* to the hermits of his district, written at their own request and for their spiritual edification. It shows a clear discernment of the dangers of the ascetic life, and a deep insight into the significance of the Augustinian doctrine of grace. About 1040 Berengar was made archdeacon of Angers. It was shortly after this that rumours began to spread of his holding heretical views regarding the sacrament of the supper. He had submitted the doctrine of transubstantiation (already generally received both

by priests and people, although it had been first unequivocally taught and reduced to a regular theory by Paschasius Radbert only in 831) to an independent examination, and had come to the conclusion that it was contrary to reason, unwarranted by Scripture, and inconsistent with the teaching of men like Ambrose, Jerome, and Augustine. He did not conceal this conviction from his scholars and friends, and through them the report spread widely that he denied the common doctrine respecting the Eucharist. His early friend and school companion, Adelman, archdeacon of Liège, wrote to him letters of exhortation on the subject of this report in 1046 and 1048; and a bishop, Hugo of Langres, wrote (about 1049) a refutation of the views which he had himself heard Berengar express in conversation. Berengar's belief was not shaken by his arguments and exhortations, and hearing that Lanfranc, the most celebrated theologian of that age, strongly approved the doctrine of Paschasius and condemned that of Ratramnus, he wrote to him a letter expressing his surprise, and urging him to reconsider the question. The letter arriving at Bec when Lanfranc was absent at Rome, was sent after him, but was opened before it reached him, and brought under the notice of Pope Leo IX. Because of it Berengar was condemned as a heretic, without being heard, by a synod at Rome and another at Verceil, both held in 1050. His enemies in France cast him into prison; but the bishop of Angers and other powerful friends, of whom he had a considerable number, had sufficient influence to procure his release. At the Council of Tours (1054) he found a protector in the Papal legate, the famous Hildebrand, who, satisfied himself with the fact that Berengar did not deny the real presence of Christ in the sacramental elements, succeeded in persuading the assembly to be content with a general confession from him that the bread and wine, after consecration, were the body and blood of the Lord, without requiring him to define how. Trusting in Hildebrand's support, and in the justice of his own cause, he presented himself at the Synod of Rome in 1059, but found himself surrounded by fierce and superstitious zealots, who forced him by the fear of death to signify his acceptance of the doctrine "that the bread and wine, after consecration, are not merely a sacrament, but the true body and the true blood of Christ, and that this body is touched and broken by the hands of the priests, and ground by the teeth of the faithful, not merely in a sacramental but in a real manner." He had no sooner done so than he bitterly repented his weakness; and acting, as he himself says, on the principle that "to take an oath which never ought to have been taken is to estrange one's self from God, but to retract what one has wrongfully sworn to, is to return back to God," when he got safe again into France he attacked the transubstantiation theory more vehemently than ever. He continued for about sixteen years to disseminate his views by writing and teaching, without being directly interfered with by either his civil or ecclesiastical superiors, greatly to the scandal of the multitude and of the zealots, in whose eyes Berengar was "ille apostolus Satane," and the academy of Tours the "Babylon nostri temporis." An attempt was made at the Council of Poitiers in 1075 to allay the agitation caused by the controversy, but it failed, and Berengar narrowly escaped death in a tumult raised by fanatics. Hildebrand, now Gregory VII., next summoned him to Rome, and, in a synod held there in 1078, tried once more to obtain a declaration of his orthodoxy by means of a confession of faith drawn up in general terms; but even this strong-minded and strong-willed Pontiff, although sincerely anxious to befriend the persecuted theologian, and fully alive to the monstrous character of the dogma of transubstantiation as propounded by Pope Nicholas II. and

Cardinal Humbert at the synod held in 1059, was at length forced to yield to the demands of the multitude and its leaders; and in another synod at Rome (1079), finding that he was only endangering his own position and reputation, he turned unexpectedly upon Berengar and commanded him to confess that he had erred in not teaching a change *as to substantial reality* of the sacramental bread and wine into the body and blood of Christ. "Then," says Berengar, "confounded by the sudden madness of the Pope, and because God in punishment for my sins did not give me a steadfast heart, I threw myself on the ground, and confessed with impious voice that I had erred, fearing the Pope would instantly pronounce against me the sentence of condemnation, and, as a necessary consequence, that the populace would hurry me to the worst of deaths." He was kindly dismissed by the Pope not long after, with a letter recommending him to the protection of the bishops of Tours and Angers, and another pronouncing anathema on all who should do him any injury or call him a heretic. He returned home overwhelmed with shame and bowed down with sorrow for having a second time been guilty of a great impiety. He immediately recalled his forced confession, and besought all Christian men "to pray for him, so that his tears might secure the pity of the Almighty." He now saw, however, that the spirit of the age was against him, and hopelessly given over to the belief of what he had combated as a delusion. He withdrew, therefore, into solitude, and passed the rest of his life in retirement and prayer on the island of St Côme near Tours. He died there in 1088. In Tours his memory was held in great respect, and a yearly festival at his tomb long commemorated his saintly virtues.

Berengar left behind him a considerable number of followers. All those who in the Middle Ages denied the substantial presence of the body and blood of Christ in the Eucharist were commonly designated Berengarians. These so-called Berengarians differed, of course, in many respects from one another, even in regard to the nature of the supper. Berengar's own views on the subject may be thus summed up:—1. That bread and wine should become flesh and blood and yet not lose the properties of bread and wine was, he held, contradictory to reason, and therefore irreconcilable with the truthfulness of God. A change which would leave behind the properties or predicates of bread and wine, yet take away their substances, the subjects of these predicates, seemed to him inherently incredible. In working out the proof of this position he showed very considerable dialectical skill. At the same time he employed so many arguments, based on what is called nominalism, that his theory of the Eucharist has been described by M. de Remusat as "nominalism limited to a single question." 2. He admitted a change (*conversio*) of the bread and wine into the body of Christ, in the sense that to those who receive them they are transformed by grace into higher powers and influences—into the true, the intellectual, or spiritual body of Christ—so as to sustain and impart the life eternal. Christ does not descend from heaven to be portioned out by the hands of priests and received into the mouths of communicants, but the hearts of true believers ascend to Christ in heaven, receive into themselves his true and imperishable body, and partake thereof in a spiritual manner. The unbelieving receive the external sign or *sacramentum*; but the believing receive in addition, truly although invisibly, the reality represented by the sign, the *res sacramenti*. Berengar draws his reasons for this view from Scripture. In confirmation of its correctness he adduces the testimonies of the earlier church teachers. 3. He rejected the notion that the sacrament of the altar was a constantly renewed sacrifice, and held it to be merely a commemoration of the one sacrifice

of Christ. 4. He dwelt strongly on the importance of men looking away from the externals of the sacrament to the spirit of love and piety which they presuppose, and the divine power and grace, through the operation of which alone they can become channels of religious life. The transubstantiation doctrine seemed to him full of evil, from its tendency to lead men to overvalue what was sensuous and transitory in the sacrament, and to neglect what was spiritual and eternal. 5. He rejected with indignation the miraculous stories told to confirm the doctrine of transubstantiation. He saw in these legends unworthy inventions originated to awe and influence ignorant and superstitious minds. On this account he was falsely accused of denying miracles altogether. 6. Reason and Scripture seemed to him the only grounds on which a true doctrine of the Lord's supper could be rested. He had a confidence in reason very rare in the 11th century, but was no rationalist. He attached little importance to mere ecclesiastical tradition or authority, and none to the voice of majorities, even when sanctioned by the decree of a Pope. In this, as in other respects, he was a precursor of Protestantism.

The opinions of Berengar are to be ascertained from the works written in refutation of them by Adelmann, Lanfranc, Guithund, &c.; from the fragments of the *De sac. coma adn. Lanfr. lib.*, edited by Stäudlin (1820-29); and from the *Liber posterior*, edited by A. F. and F. T. Vischer (1834). See also the *Berengarius Parmensis* of Lessing (1770), and especially of Eudendorf (1856); the *Cherub's Histories of Gieseler*, ii. 398-411 (Eng. transl.), and Neander, vi. 221-230 (Eng. transl.); Prantl's *Geschichte der Logik*, ii. 70-75, and Hauréan's *Histoire de la Philosophie Scolastique*, i. 225-228. (R. F.)

BERENICE, an ancient city on the western shore of the Red Sea, in 23° 56' N. lat. and 35° 34' E. long., near the head of the *Sinus Immanus* or Foul Bay. It was founded or enlarged by Ptolemy II., and grew into great importance as an entrepôt for the trade between Asia and Africa. Its harbour was sheltered on the north-east by an island that had topaz deposits, and in the neighbourhood were emerald mines. The ruins of a temple in the Egyptian style, but with Greek ornaments, are among the most important discovered on the site.

BERENICE, the name of several Egyptian and Jewish princesses. The two most generally known are—

1. BERENICE, the daughter of Magus, king of Cyrene, and the wife of Ptolemy Euergetes, of Egypt. During her husband's absence on an expedition to Syria, she dedicated her hair to Venus for his safe return, and placed it in the temple of the goddess at Zephyrium. The hair having by some unknown means disappeared, Conon, the mathematician, explained the phenomenon in courtly phrase, saying that it had been carried to the heavens and placed among the stars. The name *Coma Berenices*, applied to a constellation, commemorates this incident. Only a few lines remain of the poem in which Callimachus celebrated the transformation, but there is a fine translation of it by Catullus.

2. BERENICE, daughter of Agrippa I., king of Judæa, and born probably about 28 A.D. She was first married to her uncle, Herod, after whose death she lived for some years with her brother Agrippa, not without scandal. Her second husband was Polemo, king of Cilicia, but she soon deserted him, and returned again to Agrippa, with whom she was living when Paul appeared before him at Cæsarea. During the devastation of Judæa by the Romans, she fascinated Titus, whom she accompanied to Rome, and who would willingly have married her had it not been for the hatred cherished by the people against the Jewish race.

BEREZINA, a river of Russia, in the government of Minsk, forming a tributary of the Dnieper. It rises in the marshes of Boresoff, and has a course of more than 330 miles, for the most part through low-lying but well-

wooded country. Its width increases from 40 or 60 feet near Bobruisk to 100 feet at the mouth of the Svesloch, one of its western tributaries. As a navigable river, and forming a portion of the great canal system which unites the Black Sea with the Baltic, it is of great importance for the commerce of the country, but unfortunately it is subject to severe floods. The principal ports along its course are Boresoff, Berezhino, Yakahetsee, Bobruisk, and Parichi. In history the river has been rendered famous by the crossing of the army of Napoleon in 1812. See Stuckenberg's *Hydrographie*, iii., and *Canäle*; Güldenstadt's *Reise*.

**BEREZOFF**, a town of Asiatic Russia, capital of a circle in Tobolsk, 700 miles N. of that city, situated on three hills on the left bank of the Sosna, 13 miles above its mouth, and on the Bogul, a tributary of the Sosna, in 63° 55' N. lat. and 64° 7' E. long., at a height of 297 feet above the sea-level. Berezoff was founded in 1593 for the collection of taxes near the Ostyak settlement of Stängüt-Bozh, which means in Russian *Beresovi-Gorod*, or Birch-town. Berezoff was more than once exposed to destructive conflagrations, as, for example, in 1719. In the second quarter of the 18th century Berezoff was appointed a place of banishment for certain important royal families. In 1727 Prince Menschikoff was sent thither with his sons and two daughters, of whom the eldest, Mary, was the first bride of Peter II.; and in 1730 he was followed by Prince Ivan Dolgoruki, with his wife, father, mother, three brothers and three sisters, of whom Catherine was the second bride of Peter II. In 1742 General Osterman was sent to Berezoff with his wife, and died there in 1747. In 1783 the town was raised to the rank of chief town of a district of the Tobolsk government. In 1808 it was again burned down. In 1860 it had two stone churches, a cathedral called the Resurrection of the Lord, near which lie buried Mary Menschikoff and some of the Dolgorukis, and the church of Our Lady's Conception, built on the site of the Menschikoff building. There are in the town a departmental school, a lazaretto, and a stranger's hospital. The trade, which is of considerable importance, consists of furs, mammoth bones, dried and salted fish, &c. There is a yearly market, in which the transactions amount to £9000. Population in 1860, 1462.

**BERG** (*Ducatus Montensis*), a former duchy of Germany, on the right bank of the Rhine, bounded on the N. by the duchy of Cleves, E. by the countship of Mark and duchy of Westphalia, and on the S. and W. by the bishopric of Cologne. Its area was about 1188 square miles. The district was raised in 1108 to the rank of a countship, but did not become a duchy till the 14th century, after it had passed into the possession of the Jülich family. On the extinction of this house in 1609, Austria laid claim to the duchy as an imperial fief; but, in keeping with the wishes of the inhabitants, it was administered conjointly by the electors of Saxony and Brandenburg and the Elector Palatine till 1624, when by the Düsseldorf treaty the last of the three obtained the sole authority. In 1806 it was bestowed by Napoleon, along with the duchy of Cleves and other possessions, on Murat, who bore the title of grand duke of Berg; and after Murat's elevation to the throne of Naples, it was transferred to Louis, the son of the king of Holland. By the Congress of Vienna in 1815 it was made over to Prussia, and now forms a flourishing part of her territory.

**BERGAMA**, a town of Asia Minor, with 2500 inhabitants. See **PRYGAMUS**.

**BERGAMO**, a northern province of Italy, bounded on the N. by Sondrio, E. by Tyrol and Brescia, S. by Cremona, and W. by Milan and Como. The northern portion is mountainous and well wooded, while the southern belongs to the alluvial plain of Lombardy. To the N. and

W. of Lake Iseo there are numerous mineral wells, the most important of which are those of Trescore. Marble is abundant in the mountains, and there are valuable iron mines. At an early period the wealth of the capital appears to have been increased by the working of copper mines in the district. (See Finazzi, *Sulle antiche miniere di Bergamo*, Milan, 1860.) The vine and flax are largely grown, and the culture of the silk-worm is extensively carried on. The people speak a rough dialect, and are liable to be laughed at by the other Italians. The two stock characters of popular Italian comedy, Harlequin or Truffaldino and the sly Brighella, were both at one time represented as natives of the Bergamo district.

**BERGAMO**, the capital of the above province, is situated between the Brembo and Serio, two tributaries of the Adda, 39 miles N.E. of Milan, on the railway that runs from Venice to the Lake of Como. It consists of a new and an old town, the latter known as the *Città*, or city, being built on a hill, while the former, or *Borgo S. Leonardo*, occupies the level ground below. On the eastern side there are also two important suburbs, *S. Caterina* and *Palazzo*. Bergamo is the seat of a bishop and a prefect, and possesses a school of art known as the Accademia Carrara, a museum, a lyceum, a library contained in the Palazzo Vecchio or Broletto, a musical institute, two theatres, and various scientific societies. There are also a lunatic asylum, a hospital, and other charitable institutions. Among its numerous churches may be mentioned S. Maria Maggiore, which dates from 1173, and the neighbouring Colleoni chapel, the old Arian church of San Alessandro della Croce, S. Bartolommeo, and S. Grata. The principal objects of industry in the city are silk, cotton, and woollen goods, iron-ware, waxcloth and wax candles, and playing cards. A large fair, called the Fiera di S. Alessandro, is annually held in the new town. It dates from the 10th century, and is of great importance, especially for the silk trade. Bergamo, or *Bergomum*, was a municipal town during the Roman empire, and, after being destroyed by Attila, became one of the most flourishing cities of the Lombard kings, who made it the capital of a duchy. In the 15th century it was appropriated and fortified by the Venetians. In 1509 it was occupied by Louis XII. of France, who retained it for seven years, and then restored it to Venice. In 1796 the French again made themselves masters of the city, and constituted it the capital of their department of Serio. Bergamo was the birthplace of Tiraboschi, Rubini, and Donizetti. Population, 37,363.

**BERGAMOT**, OIL or, an essential oil obtained from the rind of the fruit of a species of *Citrus*, regarded by Risso as *C. bergamia*, but not generally believed to constitute a distinct species. The bergamot is a small tree with leaves and flowers like the bitter orange, and a round fruit nearly 3 inches in diameter, with a thin lemon-yellow smooth rind. The tree is cultivated in the neighbourhood of Reggio, in Calabria, whence the entire supply of bergamot oil is drawn. The oil is contained in small vesicles in the rind, from which it can be expressed by simple pressure in the hand. An old method of obtaining the oil, now almost superseded, is by skinning the fruit, and pressing the outside of the rind against a sponge. The rind being turned over so that the outside becomes concave, the vesicles are easily ruptured by hand pressure against the sponge, which absorbs the oil as it escapes. The oil is now obtained by placing several fruits in a saucer-shaped apparatus, the surface of which is cut into radiating sharp-edged grooves. Against the sharp edges of this dish the fruits are rapidly revolved by means of a heavy cover placed above it, which is moved by a cog wheel. The oil vessels are ruptured by pressure against the knife edges, and the oil which exudes falls through small perforations in the bottom into a vessel

placed underneath. It is allowed to rest till a greasy substance—bergamot camphor—deposits, after which it is bottled for use. Bergamot oil is a limpid greenish-yellow fluid of a specific gravity of 0.869, of a powerful but pleasant citrine odour and an aromatic bitterish taste. It consists of a mixture of two essential oils, the most volatile of which is a pure hydrocarbon isomeric with oil of turpentine; the other, containing oxygen, being regarded as a hydrate of lemon oil. The chief use of bergamot oil is in perfumery and as a flavouring material in cookery.

**BERGEN**, a city and seaport on the west coast of Norway, capital of the province of South Bergen, in 5° 29' E. long. and 60° 23' N. lat. It is situated on a rocky promontory at the head of a deep bay called the Vaag, has a fine harbour with two good entrances, and is surrounded by hills, some of which attain the height of 2000 feet. Towards the sea it is defended by the ancient fortress of Bergenhus, the citadels of Frederiksberg and Sverresberg, and some lesser works. The appearance of the town, which rises in the form of an amphitheatre and is generally well built, is decidedly picturesque, with its wooden houses painted of various colours. It contains a cathedral, several churches, of which the oldest, St Mary's, dates from the 12th century, hospitals, a lazaretto, a national museum, a diocesan college, a naval academy, a school of design, public libraries, various charitable institutions, and a theatre. It is the seat of a bishopric, and possesses a tribunal of secondary jurisdiction and one of the three public treasuries of Norway. Bergen has a considerable export trade, which consists of stockfish, lobsters, fish-roses, herrings, whale oil, horns, skins, rock moss, and timber, and is chiefly carried on with the northern countries of Europe. In 1867 the number of steamships that entered the port was 164, with a tonnage of 28,454. The imports of that year amounted to £92,600, and the exports to £344,000. Bergen was founded in the 11th century by Olaf the Peaceful, king of Norway. In 1445 the Hanseatic League established a factory in the city, and continued to have almost the sole control of the trade till 1568, when it was expelled by the Norwegians, who found its presence oppressive. There is still a kind of German colony in the place, which keeps up the Hanseatic tradition, and the old German church, hospital, and "factory" or *contor* are still extant, the latter furnishing excellent warehouse accommodation. A large part of the town was burnt down in 1858, and has since been rebuilt in a more regular and open manner. It is the second largest town in Norway. Population (1870), 30,252.

**BERGEN-OP-ZOOM**, a town of Holland, in the province of North Brabant, situated on both sides of the River Zoom, near its confluence with the East Scheldt, in 51° 29' N. lat. and 4° 17' E. long. It is about 15 miles N. of Antwerp, and 22 W.S.W. of Breda. The houses are well built, the market-places and squares handsome and spacious. It possesses a port and an arsenal, and contains a town-house, a Latin school, and an academy of design and architecture. The tower of the old castle is remarkable for an increase of its breadth from the bottom upwards, and for its liability to be rocked when struck by a strong wind. There are numerous tile-works and potteries of fine ware; and a considerable trade is carried on in anchovies caught in the Scheldt.

In the 18th century Bergen-op-Zoom became the seat of Count Gerhard of Weesmaal, who surrounded it with walls. In 1688 it was erected by Charles V. of Germany into a marquisate, which was successively held by the families of Berghes, Merode, Witthem, s'Heerenbergh, Hohenollern, Tour d'Avengne, and Salsbach, and thus passed to the house of Bavaria, which, however, in 1801 abdicated its rights in favour of the Dutch republic. In 1676 the town joined the United Netherlands, and was shortly afterwards fortified. In 1686 it was unsuccessfully besieged by the duke of Parma (see

Motley's *United Netherlands*, chap. xx.), and in 1696 it was suddenly attacked by Du Terrail (*Ibid.* chap. xlii.). In 1692 it defied the utmost attempts of Spinola, who was forced to abandon the enterprise after a siege of ten weeks and the loss of 1500 men. Its fortifications were greatly strengthened in 1688 by Coehoorn, who, it was believed, had almost rendered it impregnable; and in 1726 they were further extended. In 1747, however, the town was taken by the French general Lowendal. Restored at the end of the war, it was again in 1795 taken by Pichegru. The English, under Sir Thomas Graham, afterwards Lord Lynedoch, in March 1814 made an attempt to take it by a *coup de main*, but were driven back with great loss by the French, who, however, surrendered the place by the treaty of peace in the following May.

**BERGERAC**, the chief town of an arrondissement in the department of Dordogne, in France, situated in a fertile plain, 30 miles S.S.W. of Périgueux, on both banks of the Dordogne, which is here crossed by a fine bridge of five arches and rendered navigable by a large dam. The town is rather poorly built, and, in spite of its age, contains no monuments of antiquarian interest. It is, however, a place of great industrial activity, has a communal college, tribunals of primary jurisdiction and commerce, and a public library; and manufactures paper, iron and copper wares, hats, hosiery, and leather. The wines of the neighbourhood are in good repute, and form an important article in the trade of the town, which is principally carried on with Bordeaux and Libourne. Bergerac owes its origin to the abbey of St Martin, which was founded in 1080, and during the English invasions it played an important part as a fortress. In the 16th century it was a very flourishing and populous place, but most of its inhabitants having embraced Calvinism it suffered greatly during the religious wars. Its fortifications and citadel were demolished by Louis XIII. in 1621, and it was injuriously affected by the revocation of the Edict of Nantes. Population in 1872, 8679.

**BERGMANN**, TORBERN OLOF, Swedish chemist and naturalist, was born at Catherinberg, West Gothland, in 1735. At the age of seventeen he entered the University of Upsala, and distinguished himself by extraordinary assiduity in study, directing his attention more particularly to the natural sciences. During a residence at home rendered necessary by his weak health, he employed himself in collecting specimens of insects and plants, which he forwarded to Linnæus, who was much pleased with them. In 1756 he gained great reputation by his memoir on the *Coccus aquaticus*, which, contrary to the opinion of Linnæus, he proved to be nothing but the ovum of a certain species of leech. Some years later he was made professor of physics at Upsala, and published numerous scientific memoirs. In 1767 the chair of chemistry and mineralogy having become vacant through the resignation of Wallerius, Bergmann resolved to become a candidate. He had not hitherto devoted special attention to chemistry, but in a very short period by incredible application he produced as evidence of his fitness for the post a paper on the composition of alum, which is still regarded as a masterpiece. He was appointed to the chair, which he held till his death in 1784. In 1776 he had declined an offer from the king of Prussia inviting him to settle in Berlin. Bergmann was an unusually acute and sagacious analytical chemist, and made extensive and constant use of the laboratory. He described very carefully the properties of carbonic acid gas, and gave a valuable analysis of mineral waters. His researches in mineralogy, to which he applied his geometrical knowledge, were even more important, and led the way to Hany's discovery and classification. The theory of elective or chemical affinities, which he worked out very fully, has had great influence in the history of chemistry. A collection of Bergmann's papers was published from 1779 to 1783, *Opuscula Physica et Chémica*, 6 vols. They have been translated into French, German, and English.

BERKELEY, a market-town in the county of Gloucester, near the River Severn, on the Midland Railway. It is pleasantly situated on a gentle eminence, in a rich pastoral vale to which it gives name, and which is celebrated for its dairies, producing the famous cheese known as "double Gloucester." The town has a handsome church, a grammar school, a town-hall, a market-house, and some trade in coal, timber, malt, and cheese. Berkeley was the birthplace of the celebrated Dr Jenner, whose remains are interred in the church. Berkeley castle, on an eminence S.E. of the town, was built in the reign of Henry I. out of the ruins of a nunnery which had been in existence some time before the Conquest. It suffered considerably during the civil wars of the 17th century, but is still one of the noblest baronial castles existing in England. It is noted as the scene of the barbarous murder of Edward II. Since the time of Henry II. it has been in the hands of the Berkeley family. Population of the parish in 1871, 4607,—about a fourth of the number being in the town.

BERKELEY, GEORGE, bishop of Cloyne, one of the most subtle and original English metaphysicians, was born on the 12th March 1685, at Dysert castle, on the banks of the Nora, about two miles below Thomastown, Ireland. Not much is known of his family, who seem to have been connected with the noble English house of the same name. His father, William Berkeley, was an officer of customs, and appears to have had at one time the rank of captain in the army. We know next to nothing of the mental character of either him or his wife. George, their eldest son, was entered in 1696 at the famous Kilkenny school, of which he was not the only pupil afterwards distinguished. He was remarkably well advanced in studies for his years, and in 1700 was qualified to matriculate at Trinity College, Dublin. There, for the first time, we begin to have a fair knowledge of the circumstances in which he was placed, and of the peculiar mental qualities with which he was endowed. From his own account, and from the few notices of contemporaries, we can gather that his was a mind of peculiar subtlety, keen to probe to the very foundation any fact presented to it, and resolutely determined to rest satisfied with no doctrine which had only the evidence of authority or custom, and was not capable of being realized in consciousness. This turn of mind naturally led him somewhat off the beaten track of university studies; he was not understood by his college companions, and began to be looked upon as either the greatest dunce or the greatest genius in the university. To such a reputation his eccentricity of manner, which seems to have resulted from his occasional absorption or passionate enthusiasm, largely contributed. Of the greatest importance for the development of his rare powers in a definite direction was the general condition of thought at the time of his residence at Dublin. The older text-books of physics and philosophy were no doubt in use (Dublin in this respect has always been conservative), but alongside of them the influences of the new modes of thinking were streaming in. The opposed physical systems of Descartes and Newton had begun to be known; the new and powerful calculus was being handled; the revolution in metaphysical speculation inaugurated by Descartes had reached Dublin; and, above all, the first great English work on pure philosophy, the *Essay* of Locke, had been translated into Latin, and its doctrines were being eagerly and minutely discussed by the young Trinity College students. Add to this the undoubted influence exercised by the presence in Dublin of such men as the university provost, Peter Browne, afterwards bishop of Cork, and King, archbishop of Dublin from 1703, and it will readily be seen that Berkeley, to use Professor Fraser's words, "entered an atmosphere which was beginning to be charged with the elements of reaction

against traditional scholasticism in physics and in metaphysics."

Although more competent than any man of his time to appreciate these new movements of thought, Berkeley did not neglect the routine work of the university. He had a distinguished career, was made scholar in 1702, took his B.A. degree in 1704, and obtained a fellowship in 1707. That his interest, however, was mainly directed towards subjects purely philosophical, is evidenced partly by the share he took in setting afloat a speculative society in which the problems suggested by Descartes and Locke seem to have been discussed with infinite vigour, but, above all, by his *Common Place Book*, containing his thoughts on physics and philosophy from about the year 1703. This curious document, one of the most valuable autobiographical records in existence, throws a flood of light on the growth of Berkeley's own conceptions, and enables us to understand, far more clearly than we otherwise could, the significance of his first published works. In the *Common Place Book*, if in any writing, is to be found the keen consciousness of possessing a fresh, creative thought, the application of which will change the whole aspect of speculative science. The very first sentences refer to some new principle, and the whole book thereafter is occupied turning over and over again the new conception, showing the different aspects it assumes, and the various applications it has, bringing it face to face with possible objections, and critically considering the relation in which it stands to the fundamental thoughts of his great predecessors, Descartes, Malebranche, and Locke. So far as reading goes, the *Common Place Book* shows but a slight acquaintance with ancient or scholastic philosophies; it is evident that the author does not appreciate Spinoza; he does not refer to Leibnitz; Malebranche is frequently mentioned, but hardly in such a way as to manifest sympathetic understanding of him; Norris, the English follower of Malebranche, seems to be unnoticed; More and the Mystics, when referred to, are quoted on isolated points, and to their system the young philosopher evidently felt no attraction. Descartes and Locke, above all the latter, are his real masters in speculation, and it is from the careful consideration of their systems that the new principle has sprung to light. And what is this principle? As Professor Fraser has said, there are many ways of expressing it, and Berkeley himself has never given any very definite enunciation. To put it in a form as nearly as possible resembling the statements in the *Common Place Book*, it may be expressed in the proposition that no existence is conceivable and therefore possible which is not either conscious spirit or the ideas (i.e., objects) of which such spirit is conscious. Existing things consist of ideas or objects perceived or willed, while perception and volition are inconceivable and impossible save as the operations of mind or spirit. In the language of a later philosophy, the principle is that of the absolute synthesis of subject and object; no object exists apart from mind. Mind is therefore the deepest reality; it is the *primum* both in thought and in existence, if for the moment we assume the popular distinction between these two. From this primitive truth, which, it seems to Berkeley, merely requires careful consideration in order to be at once accepted, he never wavers. Let attention be but confined to the only possible meaning which existence can have, and, Berkeley thinks, the principle must appear self-evident. Thus he puts in a new light the perennial problems of philosophy, and instead of discussing the nature and relations of assumed entities, such as matter, substance, or cause, would ask us to consider whether or not these have any significance apart from the perceptions or volitions of conscious spirit, what in that case they do mean, and whether the supposed difficulties connected with them do

not vanish when their true interpretation is thoroughly grasped. Of all these difficulties that concerned with the nature of matter is of greatest importance to Berkeley. From misconceptions of the true nature of material substance have flowed, according to him, the materialism, scepticism, and infidelity which disfigured the age; and all these are completely banished by the new principle. The applications of his principle and his own inclinations led Berkeley into other departments of science which he was not so well qualified to handle. The first result of the principle, as he conceived it, is undoubtedly empiricism in the theory of cognition. The ultimate elements of knowledge are the minima of consciousness, presentative or representative; pure thought and abstract ideas are not capable of being realized by the mind, and are therefore impossible. The only mathematical processes to which these minima can be subjected are addition and subtraction; and consequently great part of the *Common Place Book* is occupied with a vigorous and in many points exceedingly ignorant polemic against the fundamental conceptions of the fluxional and infinitesimal calculus, a polemic which Berkeley carried on to the end of his days.

He soon began to appear as an author. In 1707 he published two short tracts on mathematics, and in 1709 the *New Theory of Vision*, in which he applied his new principle, though without stating it explicitly. The new theory is a critical examination of the true meaning of the externality which is apparently given in visual consciousness, and which, to the unphilosophical mind, is the strongest evidence of the independent existence of outer objects. Such visual consciousness is shown to be ultimately a system of arbitrary signs, symbolizing for us certain actual or possible tactual experience—in fact, a language which we learn through custom. The difference between the contents of the visual and the tactual consciousness is absolute; they have no element in common. The visible and visual signs are definitely connected with tactual experiences, and the association between them, which has grown up in our minds through custom or habit, rests upon, or is guaranteed by, the constant conjunction of the two by the will of the Universal Mind. But this synthesis, whether on the objective side as the universal thought or course of nature, or on the subjective side as mental association, is not brought forward prominently by Berkeley. It was at the same time perfectly evident that a quite similar analysis might have been applied to tactual consciousness, which does not give externality in its deepest significance any more than visual; but it was with deliberate purpose that Berkeley at first drew out only one side of his argument. In 1710 the new doctrine received its full statement in the *Principles of Human Knowledge*, where externality in its ultimate sense as independence of all mind is considered; where matter, as an abstract, unperceived substance or cause, is shown to be an impossible and unreal conception; where true substance is affirmed to be conscious spirit, true causality the free activity of such a spirit, while physical substantiality and causality in their new meaning are held to be merely arbitrary but constant relations among phenomena connected subjectively by suggestion or association, conjoined objectively in the Universal Mind. In ultimate analysis, then, nature is conscious experience, and forms the sign or symbol of a divine, universal intelligence and will.

In the preceding year Berkeley had been ordained as deacon, and in 1711 he delivered his *Discourse on Passive Obedience*, in which he deduces moral rules from the intention of God to promote the general happiness, thus working out a theological utilitarianism, which may with advantage be compared with the later expositions of Austin and Mill. From the year 1707 he had been engaged as

college tutor; in 1712 he paid a short visit to England, and in April of the following year he was presented by Swift at court. His splendid abilities and fine courteous manners, combined with the purity and uprightness of his character, made him a universal favourite. While in London he published his *Dialogues* (1713), a more popular exposition of his new theory; for exquisite facility of style these are perhaps the finest philosophical writings in the English language. In November of the same year he became chaplain to Lord Peterborough, whom he accompanied on the Continent, returning in August 1714. He travelled again in 1715 as tutor to the son of Dr Ash, and was absent from England for five years. On his way home he wrote and sent to the French Academy the essay *De Motu*, in which is given a full account of his new conception of causality, the fundamental and all-comprehensive thought in his philosophy. In 1721, during the disturbed state of social relations consequent on the bursting of the the great South Sea bubble, he published an *Essay towards preventing the Ruin of Great Britain*, which shows the intense interest he took in all practical affairs. In the same year he returned to Ireland as chaplain to the duke of Grafton, and was made divinity lecturer and university preacher. In 1722 he was appointed to the deanery of Dromore, a post which seems to have entailed no duties, as we find him holding the offices of Hebrew lecturer and senior proctor at the university. The following year brought him an unexpected addition of fortune, Miss Vanhomrigh, Swift's Vanessa, having left him half her property. It would appear that he had only met her once at dinner. In 1721 he was nominated to the rich deanery of Derry, but he hardly been appointed before he was using every effort to resign it in order to devote himself to his enthusiastically conceived scheme of founding a college in the Bermuda, and extending its benefits to the Americans. With infinite exertion he succeeded in obtaining from Government a promise of £20,000, and, after four years spent in preparation, sailed in September 1728, accompanied by some friends and by his wife, daughter of Judge Forster, whom he had married in the preceding month. Their destination was Rhode Island, where they resolved to wait for the promised grant from Government. Three years of quiet retirement and study were spent in the island. Berkeley bought a farm, made many friends, and endeared himself to the inhabitants. But it gradually became apparent that Government would never hand over the promised grant, if indeed they had ever seriously contemplated doing so. Berkeley was therefore compelled reluctantly to give up his cherished plan. Soon after his return he published the fruits of his quiet studies in *Alciphron, or the Minute Philosopher* (1733), a finely written work in the form of dialogue, critically examining the various forms of free-thinking in the age, and bringing forward in antithesis to them his own theory, which shows all nature to be the language of God. The work was extremely popular. In 1734 he was raised to the bishopric of Cloyne, and at once went into residence. The same year, in his *Analyst*, he attacked the higher mathematics as leading to free-thinking; this involved him in a hot controversy. The *Querist*, a practical work in the form of questions on what would now be called social or economical philosophy, appeared in three parts, 1735, 1736, 1737. In 1744 was published the *Siris*, partly occasioned by the controversy with regard to tar-water, but rising far above the petty circumstance from which it took its rise, and in its chain of reflections revealing the matured thoughts and wide reading of its author, while opening up hidden depths in the Berkeleyian metaphysics. In 1751 his eldest son died, and in 1752 he removed with his family to Oxford for the sake of his son George who was studying there. On the even-

ing of the 14th January 1753, he expired suddenly and painlessly in the midst of his family. And thus quietly closed one of the purest and most beautiful lives on record. His remains were deposited in Christ Church, Oxford.

Although Berkeley's new principle is susceptible of brief statement, it is by no means equally possible to give in short compass an adequate account of its systematic application to the several problems of philosophy. It may be sufficient here to indicate generally the relation of the new conception to preceding systems, and to inquire how far the principle is metaphysically justifiable. In the philosophies of Descartes and Locke a large share of attention had been directed to the idea of matter, which was held to be the abstract, unperceived background of real experience, and was supposed to give rise to our ideas of external things through its action on the sentient mind. Knowledge being limited to the ideas produced could never extend to the unperceived matter, or substance, or cause which produced them, and it became a problem for speculative science to determine the grounds for the very belief in its existence. Philosophy seemed about to end in scepticism or in materialism. Now Berkeley put this whole problem in a new light by pointing out that a preliminary question must be raised and answered. Before we deduce results from such abstract ideas as cause, substance, matter, we must ask what in reality do these mean,—what is the actual content of consciousness which corresponds to these words? Do not all these ideas, when held to represent something which exists absolutely apart from all knowledge of it, involve a contradiction? Are they not truly, when so regarded, inconceivable, and mere arbitrary fictions which cannot possibly be realized in consciousness? In putting this question, not less than in answering it, consists Berkeley's distinct originality as a philosopher. The essence of the answer, as has been already seen, is that the universe is inconceivable apart from mind,—that existence, as such, denotes conscious spirits and the objects of consciousness. Matter and external things, in so far as they are thought to have an existence beyond the circle of consciousness, are impossible, inconceivable, absurd. External things are things known to us in immediate perception. To this conclusion Berkeley seems, in the first place, to have been led by the train of reflection that naturally conduces to subjective or egoistic idealism. It is impossible to overstep the limits of self-consciousness; whatever words I use, whatever notions I have, must refer to and find their meaning in facts of consciousness. And there can be no doubt that in certain earlier aspects of his theory, where, for example, it appears as a mere analysis of what is meant by reality, it does not rise above this subjective stand-point. But this is by no means the whole or even the principal part of Berkeley's philosophy; it is essentially a theory of causality, and this is brought out gradually under the pressure of difficulties in the first solution of the early problem. To merely subjective idealism, sense percepts differ from ideas of imagination in degree, not in kind; both belong to the individual mind. To Berkeley, however, the difference is fundamental; sense ideas are not due to our own activity, they do not result from our will; they must therefore be produced by some other will,—by the divine intelligence. Sense experience is thus the constant action upon our minds of supreme active intellect, and is not the consequence of dead inert matter. It might appear, therefore, that sensible things had an objective existence in the mind of God; that an idea so soon as it passes out of our consciousness passes into that of God. This is an interpretation, frequently and not without some justice, put upon Berkeley's own expression. But it is not a satisfactory account of his theory. Berkeley is compelled to see that an immediate perception is not a thing, and that what we consider permanent or substantial is not a sensation but a group of qualities, which in ultimate analysis means sensations either immediately felt or such as our experience has taught us would be felt in conjunction with these. Our belief in the reality of a thing may therefore be said to mean assurance that this association in our minds between actual and possible sensations is somehow guaranteed. Further, Berkeley's own theory would never permit him to speak of possible sensations, reasoning by that the ideas of sensations called up to our minds by present experience. He could never have held that these afforded any explanation of the permanent existence of real objects. His theory is quite distinct from this, which really amounts to nothing more than subjective idealism. External things are produced by the will of the divine intelligence; they are caused, and caused in a regular order; there exist in the divine mind archetypes, of which sense experience may be said to be the realization in our finite minds. Our belief in the permanence of something which corresponds to the association in our minds of actual and possible sensations means belief in the orderliness of nature; and that is merely assurance that the universe is pervaded and regulated by mind. Human science is occupied in endeavouring to decipher the divine ideas which find realization in our limited experience, in trying to interpret the divine language of which natural things are the words and letters, and in striving to bring human conceptions into harmony with the divine thoughts.

Instead, therefore, of fate or necessity, or matter, or the unknown, a living, active mind is looked upon as the centre and spring of the universe, and this is the essence of the Berkeleyan metaphysics.

It may be safely said that the deeper aspects of Berkeley's new thought have been almost universally neglected or misunderstood. Of his spiritual empiricism only one side has been accepted by later thinkers, and has been looked upon as the whole. The subjective mechanism of association which with Berkeley is but part of the true explanation, and is dependent on the objective realization, in the divine mind, has been received as in itself a satisfactory theory. *Sunt Cogitationes* has been regarded by thinkers who profess themselves Berkeleyans as the one proposition warranted by consciousness; the empiricism of his philosophy has been eagerly welcomed, while the spiritual intuition, without which the whole is to Berkeley meaningless, has been cast aside. For this he is himself in no small measure to blame. The deeper spiritual intuition, present from the first, was only brought into clear relief in order to meet difficulties in the earlier statements; and the extension of the intuition itself beyond the limits of our own consciousness, which completely removes his position from mere subjectivism, rests on foundations uncritically assumed, and at first sight irreconcilable with certain positions of his system. The necessity and universality of the judgments of causality and substantiality are taken for granted; and there is no investigation of the place held by these notions in the mental constitution. The relation between the divine mind and finite intelligence, at first thought as that of agent and recipient, is complicated and obscure when the necessity for explaining the permanence of real things comes forward. The divine archetypes, according to which sensible experience is regulated and in which it finds its real objectivity, are different in kind from mere sense ideas, and the question then arises whether in these we have not again the "things as they are," which Berkeley at first so contemptuously dismissed. He leaves it undetermined whether or not our knowledge of sense things, which is never entirely presentative, involves some reference to this objective course of nature or thought of the divine mind. And if so, what is the nature of the notions necessarily implied in the simplest knowledge of a thing, as distinct from mere sense feeling? That in knowing objects certain thoughts are implied which are not presentations or their copies, is at times dimly seen by Berkeley himself; but he was content to propound a question with regard to those notions, and to look upon them as merely Locke's ideas of relation. Such ideas of relation are in truth the stumbling-block in Locke's philosophy, and Berkeley's empiricism is equally far from accounting for them.

With all these defects, however, Berkeley's new conception marks a distinct stage of progress in human thought. His true place in the history of speculation may be seen from the simple observation that the difficulties or obscurities in his scheme are really the points on which later philosophy has turned. He once for all lifted the problem of metaphysics to a higher level, and, in conjunction with his great successor, Hume, determined the form into which later metaphysical questions have been thrown.

The classical edition of Berkeley's works is that by Professor Fraser (4 vols.—vols. i.—iii., *Works*; vol. iv., *Life, Letters, and Dissertation on his Philosophy*, Clarendon Press, 1871), who has been the first, there and in various essays, to exhibit the true form of Berkeley's philosophy. See also Ueberweg's notes to his translation of the *Principles* (1869); Krauth's American edition of the *Principles*, with Prof. Fraser's introduction and notes, and a translation of those of Ueberweg; Collins's *Universal Immaterialism* (1847); *Nature and Elements of the External World* (1862); Friedrich, *Ueber Berkeley's Idealismus* (1870). Discussions on various points of Berkeley's doctrine will be found in Fichte's *Zeitschrift*, vol. lvi. 299; Mill's *Dissertations*, vols. ii. and iv.; Huxley, *Critiques and Addresses*, p. 320, 299; Ferrier, *Remains*, vol. ii. Two adverse reviews of the *Theory of Vision* may also be noted—Bailey, *Review of Berkeley's Theory of Vision* (1842); and Abbott, *Sight and Touch* (1864); with the last may be compared Monck, *Space and Vision*. (R. AD.)

BERKHAMPSTEAD, GREAT, a market-town of England, in the county of Herts, 26 miles N.W. of London, on the Junction Canal and the North-Western Railway. It has a spacious cruciform church, with a tower of the 16th century, a market-house, erected in 1860, which includes a corn exchange and a library, a grammar school, a free school, several almshouses, a jail, &c. Straw-plaiting and the manufacture of small wooden wares are the principal industries. The town is of considerable antiquity, and was one of the royal residences under the Mercian kings, a distinction which it again enjoyed under Henry II. The castle, at that time a fortress of some importance, was bestowed on the Black Prince, and since then the manor has remained an appanage of the successive princes of

Wales. The poet Cowper was born in the rectory in 1731. Population in 1872, 4083.

BERKSHIRE, one of the south-eastern counties of England, bounded on the N.E. by Buckinghamshire, from which it is separated by the Thames; N. by Oxfordshire and a small portion of Gloucester; W. by Wilts; S. by Hants; and S.E. by Surrey. It is of a very irregular figure, extending from east to west fully 60 miles; while from north to south, in its widest part, it is about 35 miles, and in its narrowest part, at Reading, not more than 7. Area, 450,132 acres.

In respect to the character of its surface and soil, the county may be conveniently regarded as consisting of two divisions—the eastern, containing the six districts east and inclusive of Bradfield, and the western, embracing the remaining six districts. The surface of the eastern division is partly level and partly undulating, and in many places, as at Windsor, it is beautifully wooded. The highest ground is at Bagshot Heath, a sandy plateau 460 feet high, at the south-east corner of the county. The character of the soil in the eastern division is considered poorer than in the west, and consists mostly of blue clay and gravel, resting on a chalk formation. In this division, tillage, dairy farming, and manufacturing are more extensively pursued than in the other, and it is consequently more thickly populated. The western or upland division contains a large proportion of elevated ground, and its soil is a reddish gravelly loam. Here a line of chalk hills, reaching from Aldworth to Ashbury (which includes the Iley Downs), runs east and west, separating the two fertile valleys of the Kennet and the Thames. Another range of chalk downs, known as the Cuckamaley Hills, extends from the neighbourhood of Wantage to the border of Wiltshire, the highest point being White-Horse Hill, 893 feet high. In this part of the county the rearing of sheep is largely carried on, while in the district of Hungerford, which is situated in the basin of the Kennet, the soil allows a large breadth of tillage, and a greater number of persons are engaged in agricultural pursuits there than any other district in the county.

Wheat and beans are extensively cultivated; and a species of peat found on the banks of the Kennet yields ashes that are of great value to the soils near that river. In the vales of Kennet and White-Horse dairy farming predominates. Near Faringdon pigs are extensively reared, and the breed is celebrated. The estate of Pusey, in the district of Faringdon, presents one of the best examples of high class farming, while in the eastern division the model farms in the district of Wokingham, the property of John Walter, Esq., M.P. for the county, may be referred to as the best specimens of the recent improvements in agriculture. Mr Walter's mansion at Bearwood, too, is an instance of a baronial residence seldom equalled in extent and admirable disposition.

Few parts of England are better supplied with the facilities of water communication than the county of Berks. It is connected by means of the Thames with London on the one hand, and on the other with the Severn at two separate points on that river;—one through the Thames and Severn canal, some miles below Gloucester, the other through the River Kennet and the Kennet and Avon canal by Bath and Bristol. Besides the navigable rivers, it enjoys the benefit of the Wilts and Berks canal, which connects the Thames at Abingdon with the Avon at Trowbridge in Wiltshire, and communicates with the Kennet and Avon canal. The other rivers, which all finally fall into the Thames, are the Ock, the Loddon, the Enborne, and the Lambourn.

The turnpike roads are generally good. The principal of these are the roads from London to Bath and Oxford,

both of which enter the county at Maidenhead, and soon afterwards separate, the former running S.W. to Reading, the latter nearly N.W. to Henley. Eight branches of railway intersect the county, viz., the Great Western, from Maidenhead to Reading, and from Reading to Shrivenham; the branch from Didcot to Hincley and Oxford; the Berks and Hants railway branches from Reading to Mortimer and Basingstoke, and from Reading to Newbury and Hungerford; the Reading, Guildford, and Reigate line; and the Reading, Wokingham, and Staines branch of the South-Western Railway.

Berkshire is not a manufacturing county, although the woollen manufacture was introduced here as long ago as the time of the Tudors. There are some paper-mills, particularly in the neighbourhood of Newbury, and an extensive biscuit manufactory at Reading. The chief trade consists in agricultural produce.

From its vicinity to the metropolis, the salubrity of the climate, and the general beauty of the country, few counties have more numerous seats of the nobility and gentry than are to be found in Berkshire. Among these stands prominent the royal castle of Windsor, the favourite residence of our monarchs during many centuries. There may also be mentioned Wytham Abbey (earl of Abingdon); Ashdown Park and Hamstead Marshall (earl of Craven); Colehill (earl of Radnor); Shrivenham House (Viscount Barrington); Easthamstead Park (marquis of Downshire); Englefield House (R. Benyon, Esq., M.P.); Aldermaston House (Higford Burr, Esq.); South Hill Park (Rt. Hon. Sir W. G. Hayter, Bart.); Pusey House (Sydney Bouverie Pusey, Esq.); Bearwood (John Walter, Esq., M.P.); and Lockings House (Col. Loyd Lindsay, V.C., M.P.)

The county comprises 20 hundreds, 6 municipal boroughs, and 142 parishes, besides 14 others chiefly or partially included in Berks. The county is in the diocese of Oxford and the ecclesiastical province of Canterbury. It forms an archdeaconry by itself, and is divided into the four rural deaneries of Abingdon, Newbury, Reading, and Wallingford. It is in the Oxford circuit, and the assizes are held at Reading. County courts are held at Abingdon, Faringdon, Hungerford, Maidenhead, Newbury, Reading, Wallingford, Wantage, Windsor, and Wokingham.

Berkshire returns 3 members to parliament for the county, 2 for the borough of Reading, and 1 for each of the boroughs of Abingdon, Wallingford, and Windsor.

At the three decennial enumerations the population of the county was as follows:—

Years.	Population.	Increase per cent.
1851.....	25,075	5
1861.....	37,324	4
1871.....	41,321	10

The chief increase has taken place in the eastern division of the county, where the density of the population amounted in 1871 to about 1 person to 1.5 acre; while in the western it was 1 person to 3.5 acres. The principal towns in the county are Reading (pop. 32,324), Windsor (11,769), Newbury (6602), Maidenhead (6173), Abingdon (5799), Wantage (3296), and Wallingford (2972). The population of the parliamentary districts differs from the above, as these districts include persons located beyond the boundaries of the boroughs.

Antiquities, both Roman and Saxon, are numerous in various parts of this county. Watling Street enters Berkshire from Bedfordshire at the village of Stratley, and leaves it at Newbury. Another Roman road passes from Reading to Newbury, where it divides into two branches, one passing to Marlborough in Wiltshire, and the other to Cirencester in Gloucestershire. A branch of Icknield Street passes from Wallingford to Wantage. Near Wan-



tage is a Roman camp, of a quadrangular form; and there are other remains of encampments at East Hampstead near Wokingham, at Pusey, on White-Horse Hill, and at Sindon Hill, near Wallingford. At Lawrence Waltham there is a Roman fort, and near Denchworth a fortress said to have been built by Canute the Dane, called Cherbury Castle. Barrows are very numerous in the downs in the N.W. of the county, particularly between Lambourn and Wantage. Dragon Hill is supposed to have been the burying-place of a British prince called Uther Pendragon, and near to it is Uffington Castle, supposed to be of Danish construction. On White-Horse Hill, in the same vicinity, is the rude figure of what is called a horse, although it bears a greater resemblance to a greyhound. It has been formed by cutting away the turf and leaving the chalk bare. It occupies nearly an acre of land, and is said to have been executed by Alfred to celebrate a victory over the Danes in the reign of his brother Ethelred, in the year 872. This memorial, not having been "scoured" for many years, is nearly obliterated by the growth of the turf over the chalk. It is part of the property of the earl of Craven.

Berkshire comprehended the principality inhabited by the *Atrabates*, a tribe of people who originally migrated from Gaul. Under the Romans it formed part of *Britannia Prima*, and during the Saxon heptarchy was included in the kingdom of the West Saxons. When Alfred divided the country into shires, hundreds, and parishes, it obtained the name of *Berocescire*, which was subsequently changed to that which it now bears. It was frequently the scene of military operations from the time of Offa down to the troubles in the reign of Charles I. During the civil war two battles were fought at Newbury. In 1643, after a siege, Reading was taken by the Parliamentary forces, and the Royalist party were expelled from the whole of the county except Wallingford.

BERLIN is the chief city of the province of Brandenburg, the capital of the kingdom of Prussia, and since 1871 the metropolis of the German empire. It is situated in 52° 30' 16" N. lat. and 13° 23' 16" E. long., and lies about 120 feet above the level of the Baltic. Its longest day is 16 hours 47 minutes; its shortest day is 7 hours 36 minutes. Its average annual temperature is 48·2° Fahr., the maximum recorded heat being 99·6° in 1819, and the maximum cold -16·1° Fahr. in 1823. The average rainfall is 21·74 Prussian inches, and Berlin has on the average 120 rainy, 29 snowy, and 17 foggy days in a year.

The city is built on what was originally in part a sandy and in part a marshy district on both sides of the River Spree, not far from its junction with the Havel, one of the principal tributaries of the Elbe. By its canals it has also direct water communication with the Oder. The Spree rises in the mountain region of Upper Lusatia, is navigable for the last 97 English miles of its course, enters Berlin on the S.E. as a broad sluggish stream, retaining an average width of 420 feet, and a depth of 6 or 7 feet, until it approaches the centre of the city, where it has a sudden fall of 4 feet, and leaves the city on the N.W., after receiving the waters of the Panke, again as a dull and sluggish stream, with an average width of only 160 feet, but with its depth increased to from 12 to 14 feet. Within the boundaries of the city it feeds canals, and divides into branches, which, however, reunite. The river, with its canals and branches, is crossed by about 50 bridges, of which very few have any claim to architectural beauty. Among these latter may be mentioned the Schlossbrücke, built after designs by Schinkel in the years 1822-24, with its eight colossal figures of white marble, representing the ideal stages of a warrior's career. The statues are for the most part of high artistic merit. They stand on granite pedestals, and are the work of Drake, Wolf, and other

eminent sculptors. The *Kurfürstenbrücke* is another bridge which merits notice, on account of the equestrian bronze statue of the Great Elector by which it is adorned.

The etymology of the word "Berlin" is doubtful. Some derive it from Celtic roots—*ber*, small, short, and *lyn*, a lake. Others regard it as a Wend word, meaning a free, open place. Others, again, regard it as coming from the word *wert*, a river island. Professor Paul Casel, in a recently published dissertation, derives it from the German word "Brühl," a marshy district, and the Slavonic termination "in;" thus Brühl, by the regular transmutation Bährh (compare Germ. *brunnen* and Eng. *burn*), Bährhlin. The question is likely to remain in the stage of more or less probable conjecture.

Similar obscurity rests on the origin of the city. The hypotheses which carried it back to the early years of the Christian era have been wholly abandoned. Even the Margrave Albert the Bear (d. 1170) is no longer unquestionably regarded as its founder, and the tendency of opinion now is to date its origin from the time of his great-grandsons, Otho and John. When first alluded to, what is now Berlin was spoken of as two towns, Cöln and Berlin. The first authentic document concerning the former is from the year 1237, concerning the latter from the year 1244, and it is with these dates that the trustworthy history of the city begins. Fidein, in his *Diplomatische Beiträge zur Geschichte der Stadt Berlin*, vol. iii., divides the history of the town, from its origin to the times of the Reformation, into three periods. The first of these, down to the year 1307, is the period during which the two towns had a separate administration; the second, from 1307 to 1442, dates from the initiation of the joint administration of the two towns to its consummation. The third period extends from 1442 to 1539, when the two towns embraced the reformed faith.

In the year 1565 the town had already a population of 12,000. About ninety years later, after the close of the Thirty Years' War, it had sunk to 6000. At the death of the Great Elector in 1688, it had risen to 20,000. The Elector Frederick III., afterwards King Frederick I., sought to make it worthy of a royal "residence," to which rank it had been raised in 1701. From that time onwards Berlin grew steadily in extent, splendour, and population. Frederick the Great found it, at his accession in 1740, with 90,000 inhabitants. At the accession of Frederick William IV. in 1840 it had 331,894, and in the month of July 1874, thirty-four years later, the population had nearly trebled, the exact numbers in that year being 949,144. The two original townships of Cöln and Berlin have grown into the sixteen townships into which the city is now divided, covering about 25 English square miles of land, and Berlin now takes its place as the fourth, perhaps the third, greatest city in Europe, surpassed only by London, Paris, and possibly Vienna. Its importance is now such that a bill, at present submitted by the Government to the consideration of the Legislature, proposes to raise it to the rank of a province of the kingdom.

Progress and prosperity have, however, been cleaguered by reverses and humiliations. The 17th century saw the Imperialists and Swedes, under Wallenstein and under Gustavus Adolphus, as enemies, within its walls; the 18th century, the Austrians and Russians, during the Seven Years' War; the 19th century, Napoleon I. and the French; and the year 1848 witnessed the bloody scenes of the March Revolution. But the development of constitutional government, and the triumphs of 1866 and 1870, have wiped out the memory of these dark spots in the history of the Prussian capital.

The town has grown in splendour as it has increased in numbers. Daniel, in the fourth volume of his *Handbook*

of Geography, gives the number of its public buildings as 700. Of these, its churches are the structures which lay claim to the highest antiquity, four of them dating from the 13th and 14th centuries. But in respect of its churches, both in their number and their beauty, Berlin is, relatively speaking, probably the poorest of the capitals of Christendom. It has only 48 churches and chapels belonging to the State Church, 5 Roman Catholic churches and chapels, 8 foreign and free chapels, and 3 synagogues, to satisfy the religious wants of a million of people. Nor are these over-filled. Dr Schwabe, the statistician, fixes the number of actual worshippers in all the churches on an average Sunday at less than 2 per cent. of the entire population. On the 1st of December 1871 the different creeds were

found to be represented in the following proportions:—732,351 were Protestants of the State Church, 2570 Dissenters, 51,517 Roman Catholics, 36,015 Jews, 34 of non-Christian creeds, 3854 persons whose creed was uncertain.

In secular public buildings Berlin is very rich. Entering the city at the Potsdam Gate, traversing a few hundred yards of the Leipzigerstrasse, turning into the Wilhelmstrasse, and following its course until it reaches the street, Unter den Linden, then beginning at the Brandenburg Gate and going along the Unter den Linden until its termination, there will be seen within the limits of half an hour's walk the following among other buildings, many of them of great architectural merit:—The Admiralty, the Upper House of the Prussian Legislature, the Imperial Palace,

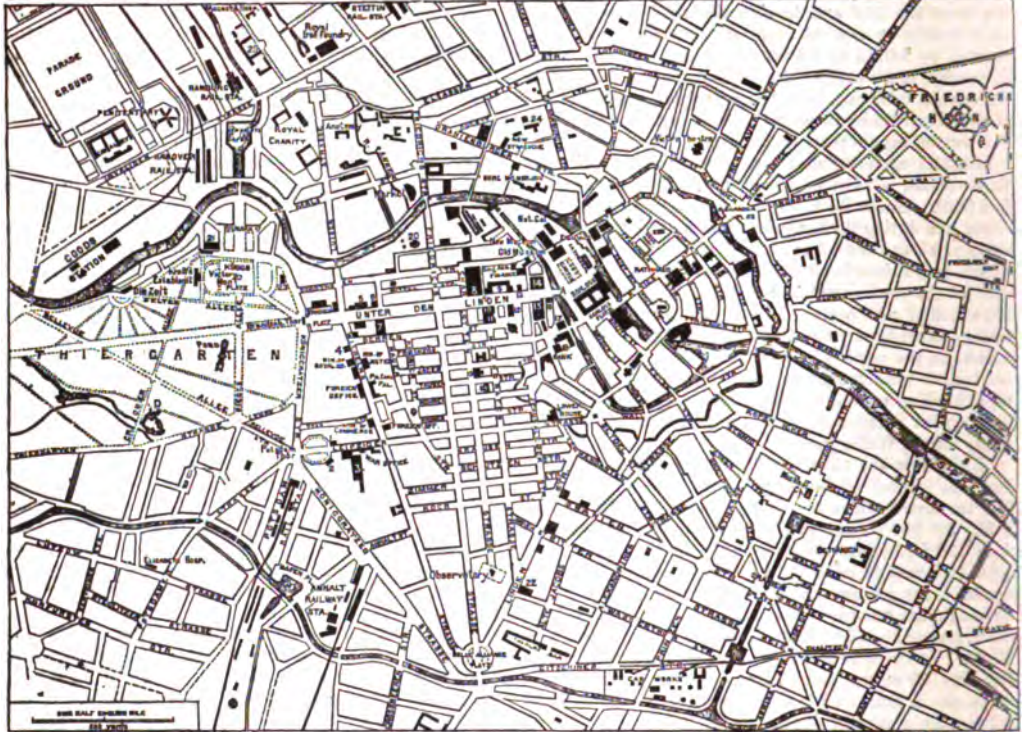

Plan of Berlin.

- A. Schloss Brücke (Castle Bridge)
- B. Lange or Kurfürsten Brücke.
- C. Monument to Frederick the Great.
- D. Monument to Frederick William III.
1. Russian Embassy.
2. Admiralty.
3. Industrial (Gewerbe) Museum.

4. Palace of Princes Alexander and George.
5. Ministry of the Interior.
6. Aquarium.
7. Russian Embassy.
8. Royal Academy.
9. University.
10. Palace of the Emperor.

11. Royal Library.
12. Opera.
13. Kdunigsvaache.
14. Zeughaus (Arsenal)
15. Palace of the Crown Prince.
16. Palace of the Commandant of Berlin.
17. Bauakademie (Architecture).

18. Mint.
19. Royal Theatre.
20. Circus (Zoo).
21. Palace of the General Staff.
22. Kammergericht (Chamber).
23. Count Rastumski's Picture Gallery.
24. Catholic Hospital.
25. Infirmary.

ment, the War Office, the residence of the Minister of Commerce, the palaces of Prince Carl and the Princes Pless and Radziwill, the Foreign Office, the Imperial Chancery, the palaces of the Ministers of the Royal House and of Justice, the palaces of the Princes Alexander and George, the Brandenburg Gate, the Royal School of Artillery and Engineering, the residences and offices of the Ministers of the Interior and of Worship, the Russian Embassy, the Great Parade, the Netherlands Palace and the palace of the Emperor, the Royal Academy, the University, the Royal Library, the Opera, the Arsenal, the palace of the Crown Prince, the palace of the Commandant of Berlin, the Castle Bridge, the Academy of Architecture, the Castle, the Cathedral, the Old and New Museums, and the National

Gallery. At a short distance from this line are the Exchange, the Rathhaus, the Mint, the Bank, and the Royal Theatre. Further away are the various barracks, the palace of the general staff, and the tight railway termini. Berlin differs from other great capitals in this respect, that with the exception of the castle,—a large building enclosing two courts, and containing more than 600 rooms, and which dates back in its origin to the 16th century,—all its public buildings are comparatively modern, dating in their present form from the 18th and 19th centuries. The public buildings and monuments which render it famous, such as the palaces, museums, theatre, exchange, bank, rathhaus, the Jewish synagogue, the monuments and columns of victory, date almost without exception from later

than 1814, the close of the great conflict with Napoleon I. The Exchange, finished in 1863, at a cost of £180,000 sterling; the Synagogue, a proud building in Oriental style, finished in 1866, at a cost of £107,000; and the Rathaus, finished in 1869, at a cost of £500,000 sterling, including the land on which it stands, are the most recent of its great buildings. The New National Gallery is nearly completed, and the Imperial Bank is being rebuilt. It is probable that no city in the world can show so large a number of fine structures so closely clustered together.

Up to a very recent date Berlin was a walled city. Those of its nineteen gates which still remain have only an historical or architectural interest. The principal of these is the Brandenburg Gate, an imitation of the Propylæa at Athens. It is 201 feet broad and nearly 65 feet high. It is supported by twelve Doric columns, each 44 feet in height, and surmounted by a car of victory, which, taken by Napoleon to Paris in 1807, was brought back by the Prussians in 1814. It has recently been enlarged by two lateral colonnades, each supported by 16 columns.

The streets, about 520 in number, are, with the exception of the districts in the most ancient part of the city, long, straight, and wide, lined with high houses, for the old typical Berlin house, with its ground floor and first floor, is rapidly disappearing. The Unter den Linden is 3287 feet long by 160 broad. The new boulevard, the Königsgrünerstrasse, is longer still, though not so wide. The Friedrichstrasse and the Oranienstrasse exceed 2 English miles in length. The city has about 60 squares. It has 25 theatres and 14 large halls for regular entertainments. It has an aquarium, zoological garden, and a floral institution, with park, flower, and palm houses. It has several hospitals, of which the largest is the Charité, with accommodation for 1500 patients. The Bethany, Elizabeth, and Lazarus hospitals are attached to establishments of Protestant deaconesses. The St Hedwig's hospital is under the care of Roman Catholic sisters. The Augusta hospital, under the immediate patronage and control of the empress, is in the hands of lady nurses, who nurse the sick without assuming the garb and character of a religious sisterhood. The people's parks are the Humboldt's Hain, the Friedrich's Hain, the Hasenheide, and, above all, the Thiergarten, a wood covering 820 Prussian acres of ground, and reaching up to the Brandenburg Gate.

As has been seen, the population has trebled itself within the last 34 years, naturally not so much by the excess of births over deaths, as by an unbroken current of immigration. In 1873 the births were 35,954, the deaths 26,427, leaving an excess of 8527 births. But the increase in the population of the city in the same year was 50,184, leaving 41,657 as the increase through the influx from without. It will thus be seen at a glance that only a minority of the population are native Berliners. In the census of 1867 it was found that, taking the population above 20 years of age, only one-third were natives of the city. The immigration is almost exclusively from the Prussian provinces, and among these principally from Brandenburg and from the eastern and north-eastern provinces. In 1871 it was found that out of every 10,000 inhabitants, 9725 were Prussian subjects, 165 were from other German states, 55 from foreign lands, and 47 were of a nationality not ascertained. The foreign element almost vanishes, and the German element is represented principally by the north, so that in blood and manners Berlin remains essentially a north-eastern German city, i.e., a city in which German, Wend, and Polish blood flows commingled in the veins of the citizens. In past times Berlin received a strong infusion of foreign blood, the influence of which is perceptible to the present day in its intellectual and social life. Such names as Savigny, Lancelotti, De la Croix, De la Cœg, Du

Bois-Reymond, tall of the French refugees who found a home here in the cold north when expelled from their own land. Daniel, in his *Geography*, vol. iv. p. 155, says that there was a time when every tenth man in the city was a Frenchman. Flemish and Bohemian elements, to say nothing of the banished Salsburgers, were introduced in a similar manner. Add to these the 86,013 Jews now resident in the city, and the picture of the commingled races which make up its population is pretty complete.

The 826,841 inhabitants of the city were found at the census of 1871 to be living in 14,478 dwelling-houses, and to consist of 178,159 households. These numbers show that the luxury of a single house for a single family is rare, and this holds good also of the wealthier classes of the people. These numbers fall far short of the present (1875) number of houses and of households, as will be seen from the fact that the value of the household property of the city in 1874 exceeded that of 1871 by £18,000,000 sterling, of which the greatest part falls to newly-built houses or houses enlarged. In 1871 the average number of persons comprised in a household was found to be 4.6, the number of households dwelling in a house 12.3, and the number of persons dwelling in a house 57.1. These numbers throw light on the moral and social life of the city, and compared with the past, show the change in the domestic habits of the people. In 1540 the average number of inmates in a house was 6, in 1740 it was 17, in 1867 it had risen to 32, and in 1871 to 57. Between the years 1864 and 1871 the one-storied houses of the city decreased 8 per cent.; the two and three-storied houses 4 per cent., while the number of four-storied houses increased 11 per cent., and the five-storied and higher houses 50 per cent. With the increase of high houses, the underground cellar dwellings, which form so striking a feature in the house architecture of the city, increase in a like proportion, and these and the attics are the dwellings of the poor. In 1867 there were 14,292 such cellar dwellings, in 1871 they had increased to 19,208. Taking the average of 1867—4 inmates to a cellar dwelling—we get 76,832 persons living under ground. In 1871 there were 4565 dwellings which contained no room which could be heated. This class of dwelling had doubled between the two census years of 1867 and 1871. Taking 3 inmates (the ascertained average of 1867) to such a dwelling, we have 13,695 persons who pass the winter in unheated dwellings, in a climate where the cold not unfrequently sinks below the zero of Fahrenheit. Of the remaining dwellings of the city, 95,423 had only one room which could be heated. This number, at 4 persons to a dwelling, give us an insight into the domestic life of 381,692 of the inhabitants of the city; that is, with the 13,695 persons mentioned above, of nearly half the population. Such dwellings engender no feeling of home, and the habits of the people are in a certain sense nomadic. In 1872, 74,568 changes of dwelling took place, involving an expense at a very moderate calculation of £158,900. In the poorer townships there were 70 removals to every 100 dwellings!

The rate of mortality is high. In 1873, a favourable year, it was 28 to every 1000 of the population. Taking the deaths as a whole, 58 per cent. were of children under 10 years of age. The rate of mortality is on the increase. Professor Virchow, in a report to the municipal authorities, stated that, dividing the last 15 years into periods of 5 years each, the general mortality in each of the three periods was as 5, 7, 9. The mortality of children under 1 year in the same three periods was as 5, 7, 11; that is, it had more than doubled. In the year 1872, out of 27,800 deaths, 11,136 were of children under 1 year.

The city is well supplied with water by works constructed by an English company, which have now become

the property of the city. English and German companies supply the city with gas. A system of underground drainage is at present in process of construction. Internal communication is kept up by means of tramways, omnibuses, and cabs. In 1873 there were 54 tram-carriages, 185 omnibuses, and 4424 cabs licensed, served by 10,060 horses.

Berlin is governed by the president of police, by the municipal authorities, and in military matters by the governor and commandant of the city. The police president stands under the minister of the interior, and has the control of all that stands related to the maintenance of public order. The municipal body consists of a burgomaster-in-chief, a burgomaster, a body of town councillors (*Stadträthe*), and a body of town deputies (*Stadtverordneten*). For municipal purposes the city is divided into 16 townships and 210 districts. For police purposes the work is divided into six departments, and an extra department for the fire brigade and street cleaning, and the *towns* into six larger and fifty smaller districts: At the head of each larger district is a police captain, at the head of each smaller district a police lieutenant.

With the exception of a few of the higher schools, which are under the direct supervision of the provincial authorities, the Berlin schools are either under the direct supervision of the municipal body or of its committee for school purposes. The schools, public and private, are divided into higher, middle, and elementary. In 1872 there were 24 higher public schools. Of these, 10 were gymnasia or schools for the highest branches of a learned education. In these schools there were 138 classes and 5073 pupils, of whom 2142 were over, and 2931 under, 14 years of age. The second class of high schools, the so-called *Realschulen*, give instruction in Latin, but otherwise devote almost exclusive attention to the departments of mathematics, science, history, modern languages, and the requirements of the higher stages of general or commercial life. Of this class of school there were also 10, with 143 classes, 5770 pupils, of whom 1931 were over, and 3839 under, 14 years of age. The remaining 4 high schools were for girls, with 54 classes, 2522 pupils, of whom 529 were over, and 1993 under, 14 years of age. In addition to these public schools there were 7 higher schools for boys, with 55 classes and 2098 pupils, and 36 higher schools for girls, with 243 classes and 6629 pupils.

Within the last five years (1875) no new school of this class has been established, but several are in process of erection. Between 1869 and 1873 the city voted about £328,747 sterling for the purchase of sites, and for enlarging and rebuilding schools of this class; and the sum still required for schools of this class, up to 1877, is £352,500 sterling.

The total number of schools of all sorts, higher, middle, and elementary, public and private, in 1872, was 232, with 1072 boys' classes, 1009 girls' classes, and 4 mixed classes—altogether, 2085; attended by 50,316 boys, 44,959 girls—altogether, 95,275 children, of whom 7309, or 7.35 per cent., were over 14 years of age. The extent to which the schools are used under the law of compulsory education is very difficult to determine. In 1867 there were 103,383 children of the school age, but only 71,814, or 69.5 per cent., were in the schools. Dr Schwabe, by a criticism of these numbers, reduces the percentage of non-attendance to 13 per cent., and maintains that even these are not all to be regarded as absolutely without instruction. In 1871 it was found that out of every 10,000 persons of 70 years of age and upwards, there were 1529 who could neither read nor write; and that out of a like number from 60 to 70, there were 860; 50 to 60, 446; 40 to 50, 234; 30 to 40, 158; 25 to 30, 155; 20 to 25, 71; 15 to 20, 53; and from 10 to 15, 48.

The scholastic life of Berlin culminates in its university,

which is, of course, not a municipal, but a national institution. It is, with the exception of Bonn, the youngest of the Prussian universities, but the first of them all in influence and reputation. It was founded in 1810. Prussia had lost her celebrated university of Halle, when that city was included by Napoleon in his newly created "kingdom of Westphalia." It was as a weapon of war, as well as a nursery of learning, that Frederick William III., and the great men whose names are identified with its origin, called it into existence, for it was felt that knowledge and religion are the true strength and defence of nations. William v. Humboldt was at that time at the head of the educational department of the kingdom, and men like Fichte and Schleiermacher worked the popular mind. It was opened on the 15th of October 1810. Its first rector was Schmalz; its first deans of faculty, Schleiermacher, Biener, Hufeland, and Fichte. Within the first ten years of its existence it counted among its professors such names as De Wette, Neander, Marheineke; Savigny, Eichhorn; Böckh, Bekker, Hegel, Raumer, Wolf, Niebuhr, and Buttman. Later followed such names as Hengstenberg and Nitsch; Homeyer, Bethman-Hollweg, Fuchs, Stahl, and Heffter; Schelling, Trendelenburg, Bopp, the brothers Grimm, Zumpt, Carl Ritter; and at the present time it can boast of such names as Twisten and Dörner; Gneist and Hinschius; Langenbeck, Bardeleben, Virchow, and Du Bois-Reymond; von Ranke, Mommsen, Curtius, Lepsius, Hoffman the chemist, and Kiepert the geographer. Taking ordinary, honorary, and extraordinary professors, licensed lecturers (*privatdozenten*), and readers together, its present professional strength consists of 15 teachers in the faculty of theology, 14 in the faculty of law, 63 in the faculty of medicine, and 96 in the faculty of philosophy—altogether, 188. The number of matriculated and unmatriculated attendants on the various lectures averages 3000 in the summer term, and 3500 in the winter. During the last two or three years, however, the number has been steadily decreasing. Berlin, in point of numbers, still stands at the head of the Prussian universities, but no longer of the German universities, being now outstripped by Leipzig.

In addition to its schools and its university, Berlin is rich in institutions for the promotion of learning, science, and the arts. It has a Royal Academy of Sciences, with 46 members, 23 in the class of physics and mathematics, and 23 in the class of philosophy and history. It was founded on the 11th of June 1700, and the name of Leibnitz is associated with its foundation. It was raised to the rank of a Royal Academy by Frederick the Great in 1743. Berlin has also a Royal Academy of Arts, consisting of 39 ordinary members (1875), under the immediate protection of the king, and governed by a director and a senate, composed of 15 members in the departments of painting, sculpture, architecture, and engraving, and 4 members in the section for music. Berlin has also its academy for vocal music, and its royal high school for music in all branches, theoretical and applied, and learned bodies and associations of the most various kinds. It has 9 public libraries, at the head of which stands the royal library, with 710,000 volumes and 15,000 manuscripts. In addition to these, there are 15 people's libraries established in various parts of the city.

Berlin possesses eight public museums, in addition to the Royal Museums and the National Gallery. The Royal Museums are the Old and the New Museums. The former, which stands on the north-east side of the Lustgarten, facing the castle, is the most imposing building in Berlin. It was built in the reign of Frederick William III., from designs by Schinkel. Its portico, supported by 18 colossal Ionic columns, is reached by a wide flight of steps. The museum covers 47,000 square feet of ground, and is 276

feet long, by 170 feet wide and 61 feet high. The back and side walls of the portico are covered with frescoes, from designs by Schinkel, executed under the direction of Cornelius, and representing, in mythical and symbolical figures, the world's progress from shapeless and chaotic to organic and developed life. The sides of the flight of steps support the well-known equestrian bronze groups of the Amazon by Kiss, and the Lion-slayer by Albert Wolff. Under the portico are monuments of the sculptors Rauch and Schadow, the architect Schinkel, and the art critic Winckelmann. The interior consists of a souterrain, containing the collection of antiquities, and of a first floor, entered from the portico through bronze doors of artistic merit, made after designs by Stüler, weighing  $7\frac{1}{2}$  tons, and executed at a cost of £3600. This floor consists of a rotunda, and of halls and cabinets of sculpture. The second floor, in a series of cabinets running round the entire building, contains the national collection of paintings. These are divided into three classes,—the Italian, French, and Spanish; the Dutch, Flemish, and German; and the Byzantine, Italian, Dutch, and German pictures down to the end of the 15th century—each of the classes being chronologically arranged. The gallery, then containing 1500 paintings, was enriched in 1874 by the valuable pictures of the Suermondt gallery, purchased by the nation at a cost of £51,000. The Suermondt gallery was rich in pictures of the old Netherland and German schools, and of the Dutch and Flemish schools. It also contained a few Spanish, Italian, and French pictures.

The New Museum is connected with the Old Museum by a covered corridor. In its interior arrangements and decoration it is undoubtedly the most splendid structure in the city. Like the Old Museum, it has three floors. The lowest of these contains the Ethnographical and Egyptian Museums and the Museum of Northern Antiquities. In the first floor, plaster casts of ancient, mediæval, and modern sculpture are found in thirteen halls in three departments. On the walls of the grand marble staircase, which rises to the full height of the building, Kaulbach's renowned cycnus of stereochromic pictures is painted, representing the six great epochs of human progress, from the confusion of tongues at the Tower of Babel and the dispersion of the nations to the Reformation of the 16th century. The uppermost story contains the collection of engravings and the gallery of curiosities.

The National Gallery is an elegant building, after designs by Stüler, situated between the New Museum and the Spree, and is intended to receive the collection of modern paintings now exhibited provisionally in the apartments of the Academy.

The public monuments are the equestrian statues of the Great Elector on the Lange Brücke, erected in 1703; Rauch's celebrated statue of Frederick the Great, "probably the grandest monument in Europe," opposite the emperor's palace, Unter den Linden; and the statue of Frederick William III. in the Lustgarten. In the Thiergarten is Drake's marble monument of Frederick William III.; and in the neighbouring Charlottenburg, Rauch's figures of the same king and the Queen Louise in the mausoleum in the Park. A second group of monuments on the Wilhelm's Platz commemorates the generals of the Seven Years' War; and a third, in the neighbourhood of the Opera, the generals who fought against Napoleon I. On the Kreuzberg, the highest spot in the neighbourhood of Berlin, a Gothic monument in bronze was erected by Frederick William III. to commemorate the victories of 1813-15; and in the Königsplatz the present emperor has erected a column of victory in honour of the triumphs of 1864, 1866, and 1870. This monument rises to the height of 197 feet, the gilded figure of Victory on the top being 40 feet high.

Literature, science, and art are represented in different parts of the city by statues and busts of Rauch, Schinkel, Thaar, Benth, Schadow, Winckelmann, Schiller, Hegel, Jahn; while the monuments in the cemeteries and churches bear the names of distinguished men in all departments of political, military, and scientific life.

Next to Leipsic, Berlin is the largest publishing centre in Germany. In the year 1872 there were 1640 works published in Berlin, of which 20 per cent. had to do with literature, 15 per cent. with philology and pedagogy, 14 per cent. with law and politics, 7 per cent. with history, 6 per cent. were military works, 5 per cent. theological, 5 per cent. had to do with agriculture, and 4 per cent. with medicine. Turning to journals and periodical literature, 265 newspapers and magazines, daily, weekly, or monthly, appeared in the same year. The political journals in Berlin do not, however, sustain the same relation to the political life of Germany as do the political journals of London and Paris to that of England and France.

Berlin is not only a centre of intelligence, but is also an important centre of manufacture and trade. Its trade and manufactures appear to be at present in a transition state—old branches are dying out, and new branches are springing into existence. Direct railway communication between the corn lands of north-eastern Germany, Poland, and Russia on the one hand, and the states of Central and Western Germany on the other, have deprived Berlin of much of its importance as a centre of trade in corn and flour. In like manner the spirit trade and manufacture have suffered. The 20,892,493 litres exported in 1870 had sunk to 9,737,597 litres in 1872. On the other hand, for petroleum, Berlin has become an emporium for the supply of the Mark of Brandenburg, part of Posen, Silesia, Saxony, and Bohemia. Silk and cotton manufacture, which in former times constituted a principal branch of Berlin manufacture, has died out. As late as 1849 Berlin had 2147 silk looms; now it has few or none. Woollen manufacture maintained its ground for a time, occupying about 8000 looms and 11,404 workmen as late as 1861. In 1874 the number of hands employed in spinning and weaving in all branches had sunk to 2918. The chief articles of manufacture and commerce are locomotives and machinery; carriages; copper, brass, and bronze wares; porcelain; and the requisites for building of every description. The manufacture of sewing-machines has assumed large proportions, from 70,000 to 75,000 being manufactured annually. According to the report of the Government inspector of factories for the city of Berlin, presented to the minister of trade and commerce, the number of persons employed in all the Berlin factories in the year 1874 was 64,466. By a "factory" was understood any wholesale manufacturing establishment employing more than 10 persons. In 1874 there were 1906 such factories at work, employing 51,464 males and 11,004 females above 16 years of age; 1137 males and 760 females under 16 and above 14 years of age; and 66 male and 14 female children under 14 years of age. The manufacture of steam-engines and machinery occupied 14,737 persons; brass-founding, metallic belt and lamp manufacture, 9074; carpentry, joinery, and wood-carving, 4548; printing, 3620; spinning and weaving, 2918; sewing-machines and telegraphic apparatus, 2788; the finer qualities of paper, 2585; porcelain and ware, 1741; dyeing, 1712; gas-works, 1518; tobacco and cigars, 1477; manufacture of linen garments, 1355; pianos and harmoniums, 1198; dressmaking and artificial flowers, 1127; brewing, 1061. None of the other branches found occupation for 1000 persons. The value of the annual exports to the United States of articles of Berlin manufacture has risen to about £1,000,000 sterling. The exports to the Brazil, the Argentine Republic, and

Japan are also increasing. Berlin is growing in importance as a money market and centre of industrial undertakings. The Berlin Cassenverein, through which the banking houses transact their business, passed £1,351,988,967 sterling through its books in 1872, as compared with £644,431,255 sterling in 1871. In 1872, 23 new banking establishments were enrolled in the trade register, with a capital of £7,565,000 sterling; and in the same year 144 new joint-stock companies were enrolled, representing a capital of £18,000,000 sterling. Since that time the tide of enterprise has ebbed, but the majority of these undertakings continue to exist.

In the progress of its growth Berlin has lost much of its original character. The numerical relations of class to class have been greatly modified. New political institutions have sprung into existence, of which the Berlin of the early years of Frederick William IV. had not a trace. It has become the seat of a parliament of the realm, and of a parliament of the empire. Manufacture and trade have come to absorb 70 per cent. of the entire population. But these have also changed their character; old branches which constituted a marked feature of its commercial and manufacturing activity have almost suddenly died out, while new branches have with equal rapidity more than supplied their place. While the commercial and manufacturing element has thus increased, other elements have undergone a relative decline. The learned professions and the civil service numbered in 1867 7.9 per cent. of the population. In 1871 the proportion had sunk to 6.11, and since then the percentage has gone on decreasing. In this altered state of affairs Berlin will have to cherish and nurture the scientific, educational, ethical, and religious elements in her life with double care, not only to keep up her old reputation abroad, but also for the purpose of preventing the degeneration of her people at home.

Sources of information:—Von Klöden, *Handbuch der Länder- und Staatenkunde von Europa*; Daniel, *Handbuch der Geographie*, vol. iv.; Fidiuin, *Historisch-Diplomatische Beiträge zur Geschichte der Stadt Berlin*, 5 vols.; Köpke, *Die Gründung der Fred. Wilhelm Universität zu Berlin*; Wiese, *Das Höhere Schulwesen in Preussen*, 3 vols. *Das Statistische Jahrbuch von Berlin*, 1867 to 1874. Dr H. Schwabe, *Resultate der Volkszählung und Volksbeschreibung vom 1<sup>ten</sup> December 1871*, Berlin, Simion. (a. p. d.)

BERLIOZ, HECTOR, by far the most original composer of modern France, was born in 1803 at Côte-Saint-André, a small town near Grenoble, in the department of Isère. His father was a physician of repute, and by his desire our composer for some time devoted himself to the study of the same profession. At the same time he had music lessons, and, in secret, perused numerous theoretical works on counterpoint and harmony, with little profit it seems, till the hearing and subsequent careful analysis of one of Haydn's quartets opened a new vista to his unguided aspirations. A similar work written by Berlioz in imitation of Haydn's masterpiece was favourably received by his friends. From Paris, where he had been sent to complete his medical studies, he at last made known to his father the unalterable decision of devoting himself entirely to art, the answer to which confession was the withdrawal of all further pecuniary assistance. In order to support life Berlioz had to accept the humble engagement of a singer in the chorus of the Gymnase theatre. Soon, however, he became reconciled to his father and entered the Conservatoire, where he studied composition under Reicha and Lesueur. His first important composition was an opera called *Les Francs-Juges*, of which, however, only the overture remains extant. In 1825 he left the Conservatoire, disgusted, it is said, at the dry pedantry of the professors, and began a course of autodidactic education, founded chiefly on the

works of Beethoven, Gluck, Weber, and other German masters. About this period Berlioz saw for the first time on the stage the talented Irish actress Miss Smithson, who was then charming Paris by her impersonations of Ophelia, Juliet, and other Shakespearian characters. The young enthusiastic composer became deeply enamoured of her at first sight, and tried, for a long time in vain, to gain the responsive love or even the attention of his idol. To an incident of this wild and persevering courtship Berlioz's first symphonic work, *Episode de la Vie d'un Artiste*, owes its origin. It describes the dreams of an artist who, under the influence of opium, imagines that he has killed his mistress, and in his vision witnesses his own execution. It is replete with the spirit of contemporary French romanticism and of self-destructive Byronic despair. A written programme is added to each of the five movements to expound the imaginative material on which the music is founded. By the advice of his friends Berlioz once more entered the Conservatoire, where, after several unsuccessful attempts, his cantata *Sardanapalus* (1830) gained him the first prize for foreign travel, in spite of the strong personal antagonism of one of the umpires. During a stay in Italy Berlioz composed an overture to *King Lear*, and *Le Retour à la Vie*,—a sort of symphony, with intervening poetical declamation between the single movements, called by the composer a melologue, and written in continuation of the *Episode de la Vie d'un Artiste*, along with which work it was performed at the Paris Conservatoire in 1832. Paganini on that occasion spoke to Berlioz the memorable words: "Vous commencez par où les autres ont fini." Miss Smithson, who also was present on the occasion, soon afterwards consented to become the wife of her ardent lover. The artistic success achieved on that occasion did not prove to be of a lasting kind. Berlioz's music was too far remote from the current of popular taste to be much admired beyond a small circle of esoteric worshippers. It is true that his name became known as that of a gifted though eccentric composer; he also received in the course of time his due share of the distinctions generally awarded to artistic merit, such as the ribbon of the Legion of Honour and the membership of the Institute. But these distinctions he owed, perhaps, less to a genuine admiration of his compositions than to his influential position as the musical critic of the *Journal des Débats* (a position which he never used or abused to push his own works), and to his successes abroad. In 1842 Berlioz went for the first time to Germany, where he was hailed with welcome by the leading musicians of the younger generation, Robert Schumann foremost amongst them. The latter paved the way for the French composer's success, by a comprehensive analysis of the *Episode* in his musical journal, the *Neue Zeitschrift für Musik*. Berlioz gave successful concerts at Leipzig and other German cities, and repeated his visit on various later occasions—in 1852, by invitation of Liszt, to conduct his opera, *Benvenuto Cellini* (hissed off the stage in Paris), at Weimar; and in 1855 to produce his oratorio-trilogy, *L'Enfance de Christ*, in the same city. This latter work had been previously performed at Paris, where Berlioz mystified the critics by pretending to have found one part of it, the "Flight into Egypt," amongst the manuscript scores of a composer of the 17th century, Pierre Ducreé by name. Berlioz also made journeys to Vienna (1866) and St. Petersburg (1867), where his works were received with great enthusiasm. He died in Paris, March 9, 1869.

Berlioz has justly been described as the French representative of musical Romanticism, and his works are in this respect closely connected with the contemporary movement in literature known by that name. The affinity between him and Victor Hugo, for instance, is undeniable, and must be looked for deeper than in the fantastic eccentricities and breaches of the established form common

to both. His ready acknowledgment of congenial aspirations in foreign countries, so adverse to French national prejudices, may be cited as another essentially "romantic" feature in Berlioz's character. In his case, however, the predilection for English literature, as shown in the choice of several of his most important subjects from Shakespeare, Byron, and Walter Scott, may be to some extent explained from his connection with Miss Smithson, a striking instance of the relation between life and art in a man of high creative faculty.

The second powerful element in Berlioz's compositions is the influence of Beethoven's gigantic works. The grand forms of the German master's symphonies impressed him with competitive zeal, and what has been described as the "poetical idea" in Beethoven's creations soon began to run riot in the enthusiastic mind of the young medical student. But, in accordance with the aversion of his national character to indistinct ideal notions, he tried to condense the poetical essence of his inspiration in the tangible shape of a story, and in this manner became the father of what is generally called "programme-music." Whether the author of such works as *Herold en Italie*, or the *Épisode de la Vie d'un Artiste*, may lay claim to the prophet's cloak is difficult to decide; he must at any rate be accepted as a man strong in his own convictions, "a swallower of formulas," and faithful ally in the great cause of nature versus traditional artificiality, of Shakespeare against pseudo-classicism. Under such circumstances we can hardly be surprised at seeing Berlioz appreciated sooner and more lastingly in Germany than in his own country. Schumann and Liszt were, as we have mentioned, at various periods amongst the foremost promoters of his music. We subjoin a list of the more important works by Berlioz not mentioned above, viz., the symphonies *Bombé et Folia* (1834), and *Damnation de Faust* (1846); the operas *Blanc et Béatrice* (1835), and *Les Troyens* (1866); a Requiem, and *Tristia*, a work for chorus and orchestra, written on the death of his wife. Of his spirited literary productions we mention his *Voyage musical en Allemagne et en Italie* (1845), *Les Soirées d'Orchestre* (1853), *A travers Chant* (1852), and his incomparable *Traité d'Instrumentation* (1844). The characteristics of Berlioz's literary style are French *verve* and *esprit*, occasionally combined with English humour and German depth of idea. The time has hardly yet arrived for judging finally of Berlioz's position in the history of his art. His original ideas, his poetical intentions, nobody can deny; the question is whether he possesses genuine creative power to carry out these intentions, and, first of all, that broad touch of nature which leads from subjective feeling to objective rendering, and which alone can establish a lasting rapport between a great artist and posterity. To decide this question the performance of his works have as yet, unfortunately, been too few and far between. In England, particularly, only a very small fraction of his compositions has been heard. (F. H.)

**BERMUDAS, SOMERS'S ISLANDS, OR SUMMER ISLANDS**, a group in the Atlantic Ocean, the seat of a British colony, in lat. 32° 20' N. and long. 64° 50' W., about 600 miles E. by S. from Cape Hatteras on the American coast. They lie to the south of a coral reef or atoll, which extends about 24 miles in length from N.E. to S.W., by 12 in breadth. The largest of the series is Great Bermuda, or Long Island, enclosing on the east Harrington or Little Sound, and on the west the Great Sound, which is thickly studded with islets, and protected on the north by the islands of Somerset, Boaz, and Inland. The remaining members of the group, St George's, Paget's, Smith's, St David's, Cooper's, Nonsuch, &c., lie to the east, and form a semicircle round Castle Harbour. The islands are wholly composed of a white granular limestone of various degrees of hardness, from the crystalline "base rock," as it is called, to friable grit. It seems that they are in a state of subsidence and not of elevation. The caves which usually appear in limestone formations are well represented, many of them running far into the land and displaying a rich variety of stalagmites and stalactites. Among the less ordinary geological phenomena may be mentioned the "sand glacier" at Elbow Bay. The surface soil is a curious kind of red earth, which is also found in ochre-like strata throughout the limestone. It is generally mixed with vegetable matter and coral sand. There is a total want of streams and wells of fresh water, and the inhabitants are dependent on the rain, which they collect and preserve in tanks. The climate of the Bermudas has a reputation for unhealthiness which is hardly borne out, for the ordinary death-rate is only

22 per 1000. Yellow fever and typhus, however, have on some occasions raged with extreme violence, and the former has appeared four times within the space of thirty years. The maximum reading of the thermometer is about 85° 8, and its minimum 49,—the mean annual temperature being 70° Fahr., and that of March 65°. Vegetation is very rapid, and the soil is clad in a mantle of almost perpetual green. The principal kind of tree is the so-called "Bermudas cedar," really a species of juniper, which furnishes timber for small vessels. The shores are fringed with the mangrove; the prickly pear grows luxuriantly in the most barren districts; and wherever the ground is left to itself the sage-bush springs up profusely. The citron, sour orange, lemon, and lime grow wild; but the apple and peach do not come to perfection. The loquat, an introduction from China, thrives admirably. The gooseberry, currant, and raspberry, all run to wood. The oleander bush, with all its beauty, is almost a nuisance. The soil is very fertile in the growth of esculent plants and roots; and a considerable trade has grown up within recent years between Bermudas and New York, principally in arrowroot, of excellent quality, onions, Irish potatoes, and tomatoes. Regular steam communication between the island and that city is maintained, the Government subsidizing the vessels. The total value of the export of these articles in 1872 was £64,030. Medicinal plants, as the castor-oil plant, aloe, and jalap, come to great perfection without culture; and coffee, indigo, cotton, and tobacco are also of spontaneous growth. Tobacco curing ceased about 1707. Few oxen or sheep are reared in the colony, a supply being obtained from North America; but goats are kept by a large number of the inhabitants. The ass is the usual beast of burden. The indigenous Mammalia are very few, and the only Reptalia are a small lizard and the green turtle. Birds, however, especially aquatic species, are very numerous,—one of the commonest being the cardinal-grosbeak. The list includes the cat-bird, blue-bird, kingfisher, ground-dove, blue heron, sandpiper, moorhen, tropic bird, and Carolina crake. Insects are comparatively few; but ants swarm destructively in the heat of the year, and a species of antlion, a cicada (scissor-grinder), and the chigre or jigger, are common. Fish are plentiful round the coasts, and the whale-fishery was once an important industry. Gold-fish, introduced from Demerara, swarm in the ditches.

There are two towns in the Bermudas, St George's, founded in 1794, and Hamilton, founded in 1790, and incorporated in 1793. The former was the capital till the senate and courts of justice were removed by Sir James Cockburn to Hamilton, which being centrally situated, is much more convenient. The streets of St George's are close and narrow, and the drainage bad. It is a military station, the barracks lying to the east of the town. The population is about 2000. Hamilton, in the Great Bermuda, at the bottom of S bay which is entered by Trenblin's Narrows, consists of an irregular half-street fronting a line of wharves. Its principal buildings include a court-house, a legislative assembly house, a council room, a library (1839), a jail, and a large church. About a mile from the town is Langton, the governor's residence. In Inland Island is situated the royal dockyard and naval establishment. A hospital stands on the highest point, and a lunatic asylum has also been built. The bay is defended by a breakwater. On Boaz Island there is a convict station. A causeway, opened in 1871, runs from St George's through Longbird Island westward, across Castle Harbour. The harbour of St George's has space enough to accommodate the whole British navy; yet, till deepened by blasting the entrance was so narrow as to render it almost useless. A marine alip was constructed in 1865, with a capacity of 1200 tons. The chief military establishment is at Prospect

Hill. The Government consists of a governor appointed by the Crown, and a privy council of nine members appointed by the governor. The House of Assembly consists of thirty-six members, who receive salaries. The Acts are usually passed for a definite period, and require to be renewed from time to time. Much of the judicial administration is left to unpaid magistrates. The currency of the colony, which had formerly twelve shillings to the pound sterling, was assimilated to that of England in 1842. The colony is ecclesiastically attached to the bishopric of Barbados. Both Presbyterians and Wesleyans are endowed. There are numerous schools, and in 1847 an educational board was established; but the general educational condition is unsatisfactory. Of 2600 children between the ages of five and six, only about 1500 attend school. Sunday schools are of much greater importance than in England, and most of them have libraries. The revenue of the islands in 1872 was £33,256, inclusive of £1500 raised by loan; the gross expenditure was £32,236; and the public debt amounted to £17,330. The population in 1850 was 11,092, of whom 4669 were whites; by the census of 1871 it had increased to 12,121.

The discovery of the Bermudas resulted from the shipwreck of Juan Bermudez, a Spaniard (whose name they now bear), when on a voyage from Spain to Cuba with a cargo of hogs, about the year 1522. Henry May, an Englishman, suffered the same fate in 1598; and lastly, Sir George Somers shared the destiny of the two preceding navigators in 1609. Sir George was the first who established a settlement upon them, but he died before he had fully accomplished his design. In 1612 the Bermudas were granted to an offshoot of the Virginia Company, which consisted of 120 persons, 60 of whom, under the command of Mr Henry More, proceeded to the islands; and an accession of inhabitants was gained during the civil wars, many having sought a refuge from the tyranny of the ruling party in this distant sanctuary. Into the details of the history we cannot enter, but the following items are important. The first source of colonial wealth was the growing of tobacco; and at a later period the produce of the salt-lagoons at Turk's Island became a main article of trade. In 1726 Berkeley chose the Summer Islands as the seat of his projected missionary establishment. The first newspaper, the *Bermuda Gazette*, was published in 1784. See W. F. Williams, *Hist. and Stat. Account of the Bermudas*, 1848; Godet, *Bermuda, its History, &c.*, 1860.

**BERN**, or **BERNE**, a canton of Switzerland, situated between 46° 19' and 47° 30' N. lat., and between 6° 50' and 8° 28' E. long. It extends from the French and Alsace frontier south-east through the heart of the Confederacy to Valais, by which it is bounded on the S., while it has the cantons of Basel, Soleris, Aargau, Lucerne, Unterwalden, and Uri on the E., and Vaud, Freiburg, Neuchâtel on the W. Bern is the second largest canton of Switzerland, its surface being estimated at 2562 square miles. The population in 1870 amounted to 506,465, of whom 436,304 were Protestants, and 66,015 Catholics, while 1401 were Jews. German was spoken in 83,693 families, and French in 16,646, the latter language prevailing in the N.W. The canton is naturally divided into three regions, in which the climate varies with the elevation. The southern part, called the Oberland, is for its scenery the most attractive part of all Switzerland. Many of the grandest mountains of the Alpine system—such as the Grimsel, the Finsteraarhorn, the Schreckhorn, the Wetterhorn, the Eiger, and the Jungfrau—lie along the frontier chain, and numerous offshoots and valleys of great beauty stretch northward towards the central part of the canton. This latter district consists for the most part of an undulating plain, interspersed with lesser chains and hills,—the soil being fertile and well cultivated. The north is occupied with the ranges of the Jura system. The principal river in the canton is the Aar, which drains by far the larger proportion of its surface, either directly or by means of its numerous tributaries. Of these, the most important are the Saane, from the S.; the Thiele, which forms the outlet of the

lakes of Biemme and Neuchâtel; and the Emme, which gives its name to the beautiful Emmenthal. The northern corner of the canton is divided between the basins of the Rhone and the Rhine. On the upper course of the Aar are the two lakes of Brienz and Thun. The mineral wealth of the country is neither extensive nor varied; but iron-mines are worked, and gold is found in the River Emma. Quarries of sandstone, marble, and granite are abundant. The pastures in the Oberland and the Emmenthal are excellent, and cattle and horses of the best description are largely reared. The latter district also produces cheese of excellent quality, which is exported to Germany and Italy. Fruit is extensively cultivated in the central region and in the neighbourhood of the lakes of Brienz and Thun; the vine is principally grown to the north of Lake Bienna. In the forests, which are of considerable importance, the prevailing trees are the fir, the pine, and the beech. The industrial productions of the canton are cotton, woollen and flaxen stuffs, leather, watches, and wooden wares of all kinds. Bern is divided into thirty bailiwicks or prefectures, each with a local administrator. The capital is Bern, and the other chief towns are Biemme or Biel, Thun, Burgdorf or Berthoud, Porrentruy or Pruntrut, and Delémont or Delsberg. The highest legislative authority is the Great Council, the members of which are chosen in proportion to the number of the people; and the executive power is in the hands of a lesser council of nine members, chosen by the Great Council for a space of four years. The educational institutions in the canton comprise a university and two gymnasiums in the capital, and progymnasiums and colleges at Biel, Thun, Burgdorf, Neuenstadt, Porrentruy, and Delémont. There is a deaf and dumb institution at Frienisberg, and a cantonal lunatic asylum at Waldau, about a mile from Bern.

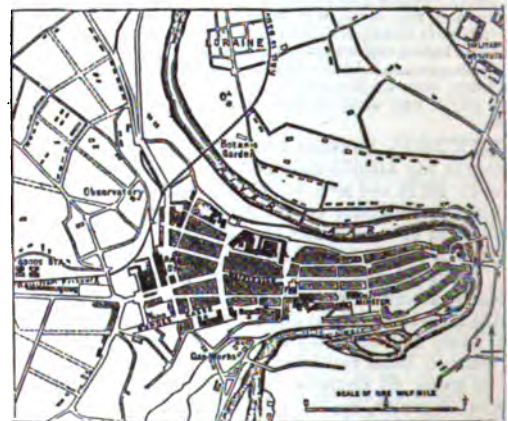

Plan of Bern.

**BERN**, the capital of the above canton, and, since 1848, the permanent seat of the Government and Diet of the Swiss Confederation. It is situated in 46° 47' N. lat. and 7° 25' E. long., at an elevation of 1710 feet above the sea, on a sandstone peninsula, formed by the windings of the Aar, which is crossed on the south side of the city by an extensive weir, and further down passes under four bridges connecting the peninsula with the right bank. It is one of the most characteristically Swiss towns; some of the streets are broad and regular, the houses being well built with hewn stone; in others a peculiar effect is produced by the presence of lines of arcades down the sides. Prominent among the public buildings is the Federal Council Hall, or *Bundes-Rathhaus*, a fine structure in the



Florentine style, which was completed in 1857. The upper story is occupied by a picture gallery of some value. The town-hall dates from 1406, and was restored in 1861. Among the ecclesiastical buildings the first place is held by the cathedral, a richly-decorated Gothic edifice, begun in 1421 and completed in 1573, from the neighbourhood of which a splendid view of the Alps is obtained. Educational institutions are very numerous, comprising a university, founded in 1834, which is attended by 250 students, a gymnasium, and a veterinary school. Attached to the university are a botanical garden and an observatory; and there are, besides, a valuable museum, a public library of 45,000 volumes, especially rich in works relating to Swiss history, and several literary and scientific societies. Among the charitable establishments are two large hospitals (the *Inselspital* and the *Bürgerspital*), a founding hospital, two orphan asylums, and a lunatic asylum. Another asylum was erected in 1854, about 2½ miles from the city. The penitentiary is capable of containing 400 prisoners. Among other buildings of interest are the granary, which, till 1830, used to be stored with corn in case of famine; the clock tower, with its automatic pantomime; the arsenal, with its mediæval treasures; the mint; and the Murtner Gate. The most frequent ornament throughout the city is the figure of the bear, in allusion to the mythical origin of the name of Bern; and the authorities still maintain a bear's den at municipal expense. Although, properly speaking, not a commercial city, Bern carries on some trade in woollen cloth, printed calico, muslin, silk stuffs, straw hats, stockings, and other articles of home manufacture. The climate is severely cold in winter, owing to the elevation of the situation. The population, which is mainly Protestant, was 36,000 in 1870.

Bern was founded, or at least fortified, by Berthold V. of Zähringen, about the end of the 12th or beginning of the 13th century, and gradually became a refuge for those who were oppressed by feudal exactions in the neighbouring countries. In 1318 it was declared a free imperial city by the Emperor Frederick II. At first its constitution was purely democratic; but in 1293 a legislative body of 200 citizens was appointed, which formed the germ of one of the most remarkable oligarchies in modern European history. The extension of territory, gradually effected by the valour of the Bernese, rendered necessary a more elaborate and rigid organization than that which had sufficed while the limits of the city were almost the limits of the state; and the power of the nobility at home was strengthened by every new success against the enemies of the city. The blow that decided the fate of Bern was struck at Laupen on June 21, 1339, when Rudolph von Erlach beat the allied army of the neighbouring states. It continued to flourish, and in 1852 joined the Swiss Confederation. A fire destroyed the city in 1406, but it was rebuilt on the same plan. In the 17th century the gradually increasing aristocratic tendency reached its climax. The adoption of new burghers was forbidden, and the burghers proper were carefully distinguished from those who were merely permanent inhabitants of the city; the burghers were divided into those capable of holding office in the state and those destitute of that privilege; and the privileged class itself, which, by 1785, numbered only 69 families, was subdivided into a higher and a lower grade. This elite grew more and more exclusive and domineering, and at last became unendurable to their humbler fellow-citizens. In 1748 the discontent made itself evident in a formidable conspiracy, of which the unfortunate Henzi was one of the leaders. The conspiracy was crushed, but the opposition broke out through other channels. At last the French Revolution came to submerge the aristocracy in a general Helvetic republic; and when the flood had passed the ancient landmarks could not be replaced, though a restoration was attempted with at first an appearance of success. The Liberal party has long been the strongest in the canton, which has at last returned almost to democracy; for, in 1870, the *referendum* was introduced, by which it is agreed that all laws, after being discussed by the Great Council, shall first receive the sanction of the people before they come into force.

**BERNADOTTE, JEAN-BAPTISTE-JULES**, afterwards KING CHARLES XIV. of Sweden and Norway, was the son of a lawyer at Pau in Béarn, and was born January 26, 1764. He was destined by his parents for the law, but chose the profession of arms, and enlisted in 1780 as a private in

the royal marine. When the Revolution swept away the arbitrary distinction of classes, and opened up to all alike the path of preferment, the abilities of Bernadotte were speedily acknowledged. In 1792 he was made a colonel, in the following year a general of brigade, and soon after a general of division. In the campaigns of the Rhine and of Italy his military talents found ample scope for display; and his diplomatic abilities had also been tested as ambassador at the court of Vienna. During Bonaparte's absence in Egypt Bernadotte was appointed minister of war. He reorganized the whole army, and prepared the way for the conquest of Holland. Notwithstanding the rivalry that all along existed between him and Napoleon, Bernadotte was made a marshal on the establishment of the empire. He was also nominated to the government of Hanover, and took part in the campaign of 1805 at the head of a force of 20,000 men. He distinguished himself at the battle of Ansterlitz, and in 1806 he was created prince of Ponte-Corvo. In 1810 the death of Prince Augustenburg of Sweden having left the throne of that kingdom without an heir, the Swedish States in Council nominated Bernadotte as successor to Charles XIII. of Sweden, a distinction for which he was scarcely less indebted to his nobility of character than to his military talents. During the great campaigns of 1813 and 1814 Bernadotte joined the coalition against Napoleon, and it was his Swedish contingent that mainly decided the battle of Leipsic. It is stated, on good authority, that he had formed the ambitious design of succeeding the emperor on the French throne. As crown prince of Sweden he devoted his whole energies to the welfare of his adopted country. Owing to the infirmities of the king he was intrusted with the entire conduct of the government. On the death of Charles XIII., in February 1818, Bernadotte ascended the throne. For the events of his administration, so conducive to the prosperity of that country, the reader is referred to the article SWEDEN. He died at Stockholm, March 8, 1844, leaving an only son, Oscar, who succeeded him.

**BERNARD, St.**, one of the most illustrious Christian teachers and representatives of monasticism in the Middle Ages, was born at Fontaines, near Dijon, in Burgundy, in 1091. The son of a knight and vassal of the duke of Burgundy who perished in the first crusade, Bernard may have felt for a time the temptations of a military career, but the influence of a pious mother and his own inclinations towards a life of meditation and study led him to the cloister. While still a youth he is said to have been "marvellously cogitative" ("*miris cogitativus*," St. Bern. *Op.*, vol. ii. col. 1063), and the ascendancy of his mind and character were soon shown. He joined the small monastery of Cîteaux in 1113 when twenty-two years of age, and such were the effects of his own devotion and eloquent enthusiasm in commending a religious life, that he drew after him not only his two younger brothers, but also his two elder ones, Guido and Gerard, both of whom had naturally taken to soldiering, and the elder of whom was married and had children. The effect of his preaching is said to have been that "mothers hid their sons, wives their husbands, companions their friends," lest they should be drawn away by his persuasive earnestness.

The monastery of Cîteaux had attracted St. Bernard not only on account of its neighbourhood (it was only a few miles distant from Dijon), but by its reputation for austerity. The monks were few and very poor. They were under an Englishman of the name of Stephen Harding, originally from Dorsetshire, whose aim was to restore the Benedictine rule to its original simplicity and give a new impulse to the monastic movement. In Bernard, Harding found a congenial spirit. No amount of self-mortification could exceed his ambition. He strove to overcome his

bodily senses altogether and to live entirely absorbed in religious meditation. Sleep he counted a loss, and compared it to death. Food was only taken to keep him from fainting. The most menial offices were his delight, and even then his humility looked around for some lowlier employment. Fortunately he loved nature, and found a constant solace in her rocks and woods. "Trust one who has tried it," he writes in one of his epistles, "you will find more in woods than in books; trees and stones will teach you what you can never learn from masters." ("Experto crede: aliquid amplius invenies in silvis quam in libris; ligna et lapides docebunt te quod a magistris audire non possis," *Epist.* 106.)

So ardent a nature soon found a sphere of ambition for itself. The monks of Cîteaux, from being a poor and unknown company, began to attract attention after the accession of St Bernard and his friends. The fame of their self-denial was noised abroad, and out of their lowliness and abnegation came as usual distinction and success. The small monastery was unable to contain the inmates that gathered within it, and it began to send forth colonies in various directions. St Bernard had been two years an inmate, and the penetrating eye of the abbot had discovered beneath all his spiritual devotion a genius of rare power, and especially fitted to aid his measures of monastic reform. He was chosen accordingly to head a band of devotees who issued from Cîteaux in 1115 in search of a new home. This band, with Bernard at their head, journeyed northwards till they reached a spot in the diocese of Langres—a thick-wooded valley, wild and gloomy, but with a clear stream running through it. Here they settled and laid the foundations of the famous abbey of Clairvaux, with which St Bernard's name remains associated in history. The hardships which the monks endured for a time in their new abode were such as to drive them almost to despair, and their leader fell seriously ill, and was only rescued from what seemed impending death by the kind compulsion of his friend William of Champeaux, the great doctor of the age, who besought and received the direction of Bernard for a year from his superior at Cîteaux. Thanks to his considerate friend the abbot of Clairvaux was forced to abandon the cares of his new establishment, and in retirement and a healthful regimen to seek renewed health. The effect was all that could be desired, and in a few years Bernard had not only recovered his strength, but had begun that marvellous career of literary and ecclesiastical activity, of incessant correspondence and preaching, which was to make him in some respects the most influential man of his age.

Gradually the influence of Bernard's character began to extend beyond his monastery. His friendship with William of Champeaux and others gave currency to his opinions, and from his simple retreat came by voice or pen an authority before which many bowed, not only within his own order but within the church at large. This influence was notably shown after the death of Pope Honorius II. in 1130. Two rival popes assumed the purple, each being able to appeal to his election by a section of the cardinals. Christendom was divided betwixt the claims of Anacletus II. and Innocent II. The former was backed by a strong Italian party, and drove his adversary from Rome and even from Italy. Innocent took refuge in France. The king, Louis the Fat, espoused his cause, and having summoned a council of archbishops and bishops, he laid his commands on the holy abbot of Clairvaux to be present also and give the benefit of his advice. With reluctance Bernard obeyed the call, and from the depths of seclusion was at once plunged into the heart of the great contest which was afflicting the Christian world. The king and prelates put the question before him in such a way as to invite his decision

and make him arbiter. After careful deliberation he gave his judgment in favour of Innocent, and not only so, but from that time forward threw himself with characteristic fervour and force into the cause for which he had declared. Not only France, but England, Spain, and Germany were won to the side of Innocent, who, banished from Rome, in the words of St Bernard, was "accepted by the world." He travelled from place to place with the powerful abbot by his side, who also received him in his humble cell at Clairvaux. Apparently, however, the meanness of the accommodation and the scantiness of the fare (one small fowl was all that could be got for the Pope's repast), left no wish on the part of Innocent or his retinue to continue their stay at Clairvaux. He found a more dainty reception elsewhere, but nowhere so powerful a friend. Through the persuasions of Bernard the emperor took up arms for Innocent; and Anacletus was driven to shut himself up in the impregnable castle of St Angelo, where his death opened the prospect of a united Christendom. A second anti-pope was elected, but after a few months retired from the field, owing also, it is said, to St Bernard's influence. A great triumph was gained not without a struggle, and the abbot of Clairvaux remained master of the ecclesiastical situation. No name stood higher in the Christian world.

The chief events which fill up his subsequent life attest the greatness of his influence. These were his contest with the famous Abelard, and his preaching of the second crusade.

Peter Abelard was twelve years older than Bernard, and had risen to eminence before Bernard had entered the gates of Cîteaux. His first intellectual encounter had been with Bernard's aged friend William of Champeaux, whom he had driven from his scholastic throne at Paris by the superiority of his dialectics. His subsequent career, his ill-fated passion for Heloise, his misfortunes, his intellectual restlessness and audacity, his supposed heresies, had all shed additional renown on his name; and when a council was summoned at Sens in 1140, at which the French king and his nobles and all the prelates of the realm were to be present, Abelard dared his enemies to impugn his opinions. St Bernard had been amongst those most alarmed by Abelard's teaching, and had sought to stir up alike Pope, princes, and bishops to take measures against him. He did not readily, however, take up the gauntlet thrown down by the great hero of the schools. He professed himself a "stripling too unversed in logic to meet the giant practised in every kind of debate." But "all were come prepared for a spectacle," and he was forced into the field. To the amazement of all, when the combatants met and all seemed ready for the intellectual fray, Abelard refused to proceed with his defence. After several passages considered to be heretical had been read from his books he made no reply, but at once appealed to Rome and left the assembly. Probably he saw enough in the character of the meeting to assure him that it formed a very different audience from those which he had been accustomed to sway by his subtlety and eloquence, and had recourse to this expedient to gain time and foil his adversaries. Bernard followed up his assault by a letter of indictment to the Pope against the heretic. The Pope responded by a sentence of condemnation, and Abelard was silenced. Soon after he found refuge at Cluny with the kindly abbot, Peter the Venerable, who brought about something of a reconciliation betwixt him and Bernard. The latter, however, never heartily forgave the heretic. He was too zealous a churchman not to see the danger there is in such a spirit as Abelard's, and the serious consequences to which it might lead.

In all things Bernard was enthusiastically devoted to the church, and it was this enthusiasm which led him at last into the chief error of his career. Bad news reached

France of the progress of the Turkish arms in the East. The capture of Edessa in 1144 sent a thrill of alarm and indignation throughout Christian Europe, and the French king was urged to send forth a new army to reclaim the Holy Land from the triumphant infidels. The Pope was consulted, and encouraged the good work, delegating to St Bernard the office of preaching the new crusade. Wary with growing years and cares the abbot of Clairvaux seemed at first reluctant, but afterwards threw himself with all his accustomed power into the new movement, and by his marvellous eloquence kindled the crusading madness once more throughout France and Germany. Not only the French king, Louis VII., but the German emperor, Conrad III., placed himself at the head of a vast army and set out for the East by way of Constantinople. Detained there too long by the duplicity of the Greeks, and divided in counsel, the Christian armies encountered frightful hardships, and were at length either dispersed or destroyed. Utter ruin and misery followed in the wake of the wildest enthusiasm. Bernard became an object of abuse as the great preacher of a movement which had terminated so disastrously, and wrote in humility an apologetic letter to the Pope, in which the divine judgments are made as usual accountable for human folly. This and other anxieties bore heavily upon even so sanguine a spirit. Disaster abroad and heresy at home left him no peace, while his body was worn to a shadow by his fasting and labours. It was, as he said, "the season of calamities." Still to the last, with failing strength, sleepless, unable to take solid food, with limbs swollen and feeble, his spirit was unconquerable. "Whenever a great necessity called him forth," as his friend and biographer Godfrey says, "his mind conquered all his bodily infirmities, he was endowed with strength, and to the astonishment of all who saw him, he could surpass even robust men in his endurance of fatigue." He continued absorbed in public affairs, and dispensed his care and advice in all directions often about the most trivial as well as the most important affairs. Finally the death of his associates and friends left him without any desire to live. He longed rather "to depart and be with Christ." To his sorrowing monks, whose earnest prayers were supposed to have assisted his partial recovery when near his end, he said, "Why do you thus detain a miserable man? Spare me. Spare me, and let me depart." He expired August 20, 1153, shortly after his disciple Pope Eugenius III.

His character appears in our brief sketch as that of a noble enthusiast, selfish in nothing save in so far as the church had become a part of himself, ardent in his sympathies and friendships, tenacious of purpose, terrible in indignation. He spared no abuse, and denounced what he deemed corruption to the Pope as frankly as to one of his own monks. He is not a thinker nor a man in advance of his age, but much of the best thought and piety of his time are sublimed in him to a sweet mystery and rapture of sentiment which has still power to touch amidst all its rhetorical exaggerations.

His writings are very numerous, consisting of epistles, sermons, and theological treatises. The best edition of his works is that of Father Mabillon, printed at Paris in 1690 in 2 vols. folio, and reprinted more than once—finally in 1854 in 4 vols. 8vo. His life, written by his friend and disciple Godfrey, is also contained in this edition of his works. (J. T.)

**BERNARD, JAMES**, professor of philosophy and mathematics, and minister of the Walloon church at Leyden, was born at Nions, in Dauphiné, September 1, 1658. Having studied at Geneva, he returned to France in 1679, and was chosen minister of Venterol, in Dauphiné, whence he afterwards removed to the church of Vinsobres. As he

continued to preach the Reformed doctrines in opposition to the royal ordinance, he was obliged to leave the country and retired to Holland, where he was well received, and appointed one of the pensionary ministers of Gouda. In July 1686 he commenced his *Histoire Abrégée de l'Europe*, which he continued monthly till December 1688. In 1692 he began his *Lettres Historiques*, containing an account of the most important transactions in Europe; he carried on this work till the end of 1698, after which it was continued by others. When Leclerc discontinued his *Bibliothèque Universelle* in 1691, Bernard wrote the greater part of the twentieth volume and the five following volumes. In 1698 he collected and published *Actes et Négociations de la Pais de Ryswic*, in four volumes 12mo. In 1699 he began a continuation of Bayle's *Nouvelles de la République des Lettrés*, which continued till December 1710. In 1705 he was unanimously elected one of the ministers of the Walloon church at Leyden; and about the same time he succeeded M. de Valder in the chair of philosophy and mathematics at Leyden. In 1716 he published a supplement to Moreeri's Dictionary, in two volumes folio. The same year he resumed his *Nouvelles de la République des Lettrés*, and continued it till his death, on the 27th of April 1718. Besides the works above mentioned, he was the author of two practical treatises, one on late repentance, the other on the excellence of religion.

**BERNARD, SIMON**, French general of engineers, and aide-de-camp to Napoleon, was born at Dôle in 1779. He was educated at the École Polytechnique, and entered the army in the corps of engineers. He rose rapidly, and served for some time as aide-de-camp to Napoleon. Subsequently to the emperor's fall he emigrated to the United States, where he executed a number of extensive military works, consisting of vast canals, numerous forts, and 1400 leagues of frontier fortifications. He returned to France after the Revolution of 1830, and in 1836 was secretary at war to Louis Philippe. He died in 1839.

**BERNARDIN, St.**, of Siena, a celebrated preacher, was born at Massa Carrara in 1380. His family, the Albizeschi, was noble, and his father was chief magistrate of Massa. He lost both parents before his eighth year, and was educated by his aunt, a pious woman. After completing his course of study he passed some years as a voluntary assistant in the hospital of Scala, and in 1404 entered the order of St Francis. His eloquence as a preacher made him celebrated throughout Italy, nor was his fame diminished by his visit to the Holy Land, from which he returned with fresh zeal. Three cities, Siena, Ferrara, and Urbino, successively sought the honour of having him as their bishop, but without avail. In 1438 he was made vicar-general of his order in Italy. He died on the 20th May 1444, at Aquila in Abruzzo. His canonization took place in 1450 by the order of Nicholas V. A collection of his works was published in 1571 by Rudolf, bishop of Sinigaglia.

**BERNAY**, the chief town of an arrondissement in the department of Eure, in France, on the left bank of the Charentonne, 26 miles W.N.W. of Evreux. It is beautifully situated in the midst of green wooded hills, and still justifies Madame de Staël's description—"Bernay is a basket of flowers." Of great antiquity, it still possesses numerous quaint wooden houses and several ancient ecclesiastical buildings of considerable interest. The abbey church is now used as a market, and the abbey, which was originally founded by Judith of Brittany about 1017, and underwent a restoration in the 17th century, serves for municipal and legal purposes. The glass-work in the church of Notre Dame de la Couture is of great antiquarian interest. Among the industrial establishments of the place are cotton, woollen, and ribband factories:

and the trade is chiefly in horses, grain, and flax. The town, which was formerly fortified, was besieged by Duguesclin in 1378; it was taken by the English in 1418 and again in 1421, and by Admiral de Coligny in 1563. The fortress was razed in 1589. Population in 1872, 5806.

**BERNBURG**, a city of Anhalt in Germany, and formerly the capital of the now incorporated duchy of Anhalt-Bernburg. It consists of three parts, the *Altstadt* or old town, the *Bergstadt* or hill-town, and the *Neustadt* or new town,—the Bergstadt on the right and the other two on the left of the River Saale, which is crossed by a rather massive stone bridge. It is a well-built city, the principal public buildings being the Government house, the church of St Mary, the Gymnasium, and the house of correction. The castle, formerly the ducal residence, is in the Bergstadt, defended by moats, and surrounded by beautiful gardens. The industries of the town include the manufacture of snuff, paper, starch, and pottery; and a considerable traffic is carried on, especially in grain, both by river and by railway. Bernburg is of great antiquity. The Bergstadt was fortified by Otto III. in the 10th century, and the new town was founded in the 13th. For a long period the different parts were under separate magistracies, the new town uniting with the old in 1560, and the Bergstadt with both in 1824. Prince Frederick Albert removed the ducal residence to Ballenstedt in 1765. Population in 1872, inclusive of the domain and the suburb of Waldau, 15,709.

**BERNE.** See **BERN.**

**BERNERS, JULIANA**, prioress of Sopewell nunnery, near St Albans, was the daughter of Sir James Berners, who was beheaded in the reign of Richard II. She was celebrated for her beauty, her spirit, and her passion for field sports. To her is attributed the *Treatyse perteynyng to Hawkyng, Huntynge, and Fysshynge with an Angle*; also a right noble *Treatyse on the Lygnage of Cot Armour, endynge with a Treatyse which speccyfeth of Blasyngs of Armys*, printed in folio by Wynkyn de Worde in 1496. The first and rarest edition, printed at St Albans in 1486, does not contain the treatise on fishing. Haalewood, who published an edition of the work (in fac-simile of that of Wynkyn de Worde) in 1811, folio, London, has examined with the greatest care the author's claims to figure as the earliest female writer in the English language. His preliminary dissertations contain all the scanty information that is to be had concerning her.

**BERNI, FRANCESCO**, Italian poet, was born about 1490 at Lamporecchio, in Bibbiena, a district lying along the Upper Arno. His family was of good descent, but excessively poor. At an early age he was sent to Florence, where he remained till his 19th year. He then set out for Rome, trusting to obtain some assistance from his uncle, the Cardinal Bibbiena. The cardinal, however, did nothing for him, and he was obliged to accept a situation as clerk or secretary to Ghiberti, datary to Clement VII. The duties of his office, for which Berni was in every way unfit, were exceedingly irksome to the poet, who, however, made himself celebrated at Rome as the most witty and inventive of a certain club of literary men, who devoted themselves to light and sparkling effusions. So strong was the admiration for Berni's verses, that mocking or burlesque poems have since been called *poesie bernesca*. About the year 1530 he was relieved from his servitude by obtaining a canonry in the cathedral of Florence. In that city he died in 1536, according to tradition poisoned by Duke Alessandro de' Medici, for having refused to poison the duke's cousin, Ippolito de' Medici; but considerable obscurity rests over this story. Berni stands at the head of Italian comic or burlesque poets. For lightness, sparkling wit,

variety of form, and fluent diction, his verses are unsurpassed. Perhaps, however, he owes his greatest fame to the recasting (*Rifacimento*) of Boiardo's *Orlando Innamorato*. The enormous success of Ariosto's *Orlando Furioso* had directed fresh attention to the older poem, from which it took its characters, and of which it is the continuation. But Boiardo's work, though good in plan, could never have achieved wide popularity on account of the extreme ruggedness of its style. Berni undertook the revision of the whole poem, avowedly altering no sentiment, removing or adding no incident, but simply giving to each line and stanza due gracefulness and polish. His task he completed with marvellous success; scarcely a line remains as it was, and the general opinion has pronounced decisively in favour of the revision over the original. To each canto he prefixed a few stanzas of reflective verse in the manner of Ariosto, and in one of these introductions he gives us the only certain information we have concerning his own life. It should be noticed that Berni appears to have been favourably disposed towards the Reformation principles at that time introduced into Italy, and this may explain the bitterness of some remarks of his upon the church. The first edition of the *Rifacimento* was printed posthumously in 1541, and it has been supposed that a few passages either did not receive the author's final revision, or have been retouched by another hand. The *Opere Burlesche* have been published separately. A partial translation of Berni's *Orlando* was published by W. S. Rose, 1823. (See for full information Panizzi's Boiardo, 1830-31.)

**BERNINI, GIOVANNI LORENZO**, an Italian artist, born at Naples in 1598, was more celebrated as an architect and a sculptor than as a painter. At a very early age his great skill in modelling introduced him to court favour at Rome, and he was specially patronized by Maffeo Barberini, afterwards Pope Urban VIII., whose palace he designed. None of his sculptured groups at all come up to the promised excellence of his first effort, the Apollo and Daphne, nor are any of his paintings of particular merit. His busts were in so much request that Charles I. of England, being unable to have a personal interview with Bernini, sent him three portraits by Vandeyck, from which the artist was enabled to complete his model. His architectural designs, including the great colonnade of St Peter's, brought him perhaps his greatest celebrity. Louis XIV., when he contemplated the restoration of the Louvre, sent for Bernini, but did not adopt his designs. The artist's progress through France was a triumphal procession, and he was most liberally rewarded by the great monarch. He died at Rome in 1680, leaving a fortune of over £100,000. Few artists have had so wide renown in their own day; time has enabled us to judge more accurately of his merits.

**BERNOULLI, or BERNOULLI**, a name illustrious in the annals of science, belonging to a family of respectability, originally of Antwerp. Driven from their country during the oppressive government of Spain for their attachment to the Reformed religion, the family sought first an asylum at Frankfort (1583), and afterwards at Basel, where they ultimately obtained the highest distinctions. In the course of a century eight of its members successfully cultivated various branches of mathematics, and contributed powerfully to the advance of science. The most celebrated of the family were James, John, and Daniel; but, for the sake of perspicuity they may be considered as nearly as possible in the order of family succession.

**I. JAMES BERNOULLI** was born at Basel on the 27th December 1654. He was educated at the public school of Basel, and also received private instruction from the learned Hoffmann, then professor of Greek. At the conclusion of his philosophical studies at the university, some

geometrical figures, which fall in his way, excited in him a passion for mathematical pursuits, and in spite of the opposition of his father, who wished him to be a clergyman, he applied himself in secret to his favourite science. In 1676 he visited Geneva on his way to France, and subsequently travelled to England and Holland. While at Geneva he taught a blind girl several branches of science, and also how to write; and this led him to publish *A Method of Teaching Mathematics to the Blind*. At Bordeaux his *Universal Tables on Dialling* were constructed; and in London he was admitted to the meetings of Boyle, Hooke, Stillingfleet, and other learned and scientific men.

On his final return to Basel in 1682, he devoted himself to physical and mathematical investigations, and opened a public seminary for experimental physics. In the same year he published his essay on comets, *Conamen Novi Systematis Cometarum*, which was occasioned by the appearance of the comet of 1680. This essay, and his next publication, entitled *De Gravitate Aëtheris*, were deeply tinged with the philosophy of Descartes, but they contain truths not unworthy of the philosophy of the *Principia*.

James Bernoulli cannot be strictly called an independent discoverer; but, from his extensive and successful application of the calculus, he is well deserving of a place by the side of Newton and Leibnitz. As an additional claim to remembrance, he was the first to solve Leibnitz's problem of the isochronous curve, and to determine the catenary, or curve formed by a chain suspended by its two extremities, which he also showed to be the same as the curvature of a sail filled with wind. This led him on to another curve, which, being formed by an elastic plate or rod fixed at one end and bent by a weight applied to the other, he called the elastic curve, and which he showed to be the same as the curvature of an impervious sail filled with a liquid. In his investigations respecting cycloidal lines and various spiral curves, his attention was directed to the loxodromic and logarithmic spirals, in the last of which he took particular interest from its remarkable property of reproducing itself under a great variety of conditions.

In 1696 he proposed the famous problem of isoperimetric figures, and offered a reward for its solution. This problem engaged the attention of British as well as Continental mathematicians; and its proposal gave rise to a painful quarrel between the brothers. John offered a solution of the problem; his brother pronounced it to be wrong. John then amended his solution, and again offered it, and claimed the reward. James still declared it to be no solution, and soon after published his own. In 1701 he published also the demonstration of his solution, which was accepted by De l'Hôpital and Leibnitz. John, however, held his peace for several years, and then dishonestly published, after the death of James, another incorrect solution; and not until 1718 did he admit that he had been in error. Even then he set forth as his own his brother's solution purposely disguised.

In 1687 the mathematical chair of the University of Basel was conferred upon James; and in the discharge of its duties he was so successful as to attract students from other countries. Some of his pupils became afterwards professors in the universities of Germany. He was once made rector of his university, and had other distinctions bestowed on him. He and his brother John were the first two foreign associates of the Academy of Sciences at Paris; and, at the request of Leibnitz, they were both received as members of the Academy of Berlin. In 1684 he had been offered a professorship at Heidelberg; but his marriage with a lady of his native city led him to decline the invitation. Intense application brought on infirmities and a slow fever, of which he died on the 16th of August 1705, with the resignation of a Christian and the firmness

of a philosopher. Like another Archimedes, he requested that, as a monument of his labours and an emblem of his hope of a resurrection, the logarithmic spiral should be engraven on his tombstone, with these words, *Eadem mutata resurgo*.

James Bernoulli wrote elegant verses in Latin, German, and French; but although these were held in high estimation in his own time, it is on his mathematical works that his fame now rests. These are—(1.) *Jacobi Bernoulli Basiliensis Opera*, Geneva, 1744, 2 tom. 4to; (2.) *Aræ Conjectandi, opus posthumum: accedunt tractatus de Seribus Infinitis, et epistola (Gallicè scripta) de Ludo Pileæ Reticularis*, Basiliæ, 1713, 1 tom. 4to.

II. JOHN BERNOULLI, brother of the preceding, was born at Basel on the 7th August 1667. His education was begun at six years of age; and after finishing his literary studies he was sent to Neufchâtel to learn commerce and acquire the French language. But at the end of a year he renounced the pursuits of commerce, returned to the University of Basel, and was admitted to the degree of bachelor in philosophy, and a year later, at the age of 18, to that of master of arts. In his studies he was aided by his elder brother James. Chemistry, as well as mathematics, seems to have been the object of his early attention; and in the year 1690 he published a dissertation on effervescence and fermentation. The same year he went to Geneva, where he gave instruction in the differential calculus to Fatio de Duiller, and afterwards proceeded to Paris, where he enjoyed the society of Malebranche, Cassini, De Lahire, and Varignon. With the Marquis de l'Hôpital he spent four months at his country house in the study of the higher geometry and the resources of the new calculus. His independent discoveries in mathematics are numerous and important. Among these were the exponential calculus, and the curve called by him the *linea brachistochrona*, or line of swiftest descent, which he was the first to determine, pointing out at the same time the beautiful relation which this curve bears to the path described by a ray or particle of light passing through strata of variable density, such as our atmosphere. On his return to his native city he studied medicine, and in 1694 took the degree of M.D. At this period he married into one of the oldest families in Basel; and although he had declined a professorship in Germany, he now accepted an invitation to the chair of mathematics at Groningen (*Commercium Philosophicum*, epist. xi. and xii.) There, in addition to the learned lectures by which he endeavoured to revive mathematical science in the university, he gave a public course of experimental physics. During a residence of ten years in Groningen, his controversies were almost as numerous as his discoveries. His dissertation on an electrical appearance of the barometer first observed by Picard, and discussed by John Bernoulli under the name of mercurial phosphorus, or mercury shining in vacuo (*Diss. Physica de Mercurio lucente in vacuo*), procured him the notice of royalty, and engaged him in controversy. Through Leibnitz he received from the king of Prussia a gold medal for his supposed discoveries; but Hartsoecker and some of the French academicians disputed the fact. The family quarrel about the problem of isoperimetric figures above mentioned began about this time. In his dispute with his brother, in his controversies with the English and Scotch mathematicians, and in his harsh and jealous bearing to his son Daniel, he showed a temper mean, unfair, and violent. He had declined, during his residence at Groningen, an invitation to Utrecht, but accepted in 1705 the mathematical chair in the university of his native city, vacant by the death of his brother James; and here he remained till his death. His inaugural discourse was on the "new analysis," which he so successfully applied in investigating

various problems both in pure and mixed mathematics. At the request of the magistracy of Basel he applied himself to correct the relaxed discipline of the university.

He was several times a successful competitor for the prizes given by the Academy of Sciences of Paris; and the subjects of his essays were, the laws of motion (*Discours sur les Loix de la Communication du Mouvement*, 1727), the elliptical orbits of the planets, and the inclinations of the planetary orbits (*Essai d'une Nouvelle Physique Céleste*, 1735). In the last case his son Daniel divided the prize with him. Some years after his return to Basel he published an essay, entitled *Nouvelle Théorie de la Manœuvre des Vaisseaux*. It is, however, his works in pure mathematics that are the permanent monuments of his fame. D'Alembert acknowledges with gratitude, that "whatever he knew of mathematics he owed to the works of John Bernoulli." He was a member of almost every learned society in Europe, and one of the first mathematicians of a mathematical age. He was as keen in his resentments as he was ardent in his friendships; fondly attached to his family, he yet disliked a deserving son; he gave full praise to Leibnitz and Euler, yet was blind to the excellence of Newton. Such was the vigour of his constitution that he continued to pursue his usual mathematical studies till the age of eighty. He was then attacked by a complaint at first apparently trifling; but his strength daily and rapidly declined till the last of January 1748, when he died peacefully in his sleep.

His writings were collected under his own eye by Cramer, professor of mathematics at Geneva, and published under the title of *Johannis Bernoulli Operi Omnia*, Lausan. et Genév. 4 tom. 4to. His interesting correspondence with Leibnitz appeared under the title of *Gul. Leibnitii et Johannis Bernoulli commercium Philosophicum et Mathematicum*, Lausan. et Genév. 1745, 2 tom. 4to.

III. NICHOLAS BERNOULLI, the eldest of the three sons of John Bernoulli, was born in 1695. His early indications of genius were carefully cherished. At the age of eight he could speak German, Dutch, French, and Latin. When his father returned to Basel he went to the university of that city, where, at the age of sixteen, he took the degree of doctor in philosophy, and four years later the highest degree in law. Meanwhile the study of mathematics was not neglected, as appears not only from his giving instructions in geometry to his younger brother Daniel, but from his writings on the differential, integral, and exponential calculus, and from his father considering him, at the age of twenty-one, worthy of receiving the torch of science from his own hands. ("Lampada nunc tradam filio meo natu maximo, juveni xxi. annorum, ingenio mathematico alisque dotibus satis instructo," *Com. Phil.* ep. 223). With his father's permission he visited Italy and France, and during his travels formed friendship with Varignon and with Riccati, one of the first mathematicians of Italy. The invitation of a Venetian nobleman induced him again to visit Italy, where he resided two years, till his return to be a candidate for the chair of jurisprudence at Basel. He was unsuccessful, but was soon afterwards appointed to a similar office in the University of Bern. Here he resided three years, his happiness only marred by regret on account of his separation from his brother Daniel, with whom he was united in sentiment and pursuits. Both were appointed at the same time professors of mathematics in the Academy of St Petersburg; but this office Nicholas enjoyed for little more than eight months. At the end of July 1726 he was cut off in the prime of life by a lingering fever. Sensible of the loss which the nation had sustained by his death, the Empress Catherine ordered him a funeral at the public expense. Some of his papers are published in his father's works, and others in the *Acta Eruditorum* and the *Comment. Acad. Petropol.*

IV. DANIEL BERNOULLI, the second son of John Bernoulli, was born 9th February 1700, at Groningen. He studied medicine and became a physician, but his attention was early directed also to geometrical studies. The severity of his father's manner was ill calculated to encourage the first efforts of one so sensitive; but fortunately, at the age of eleven, he became the pupil of his brother Nicholas. He afterwards studied in Italy under Michelotti and Morgagni. After his return, though only twenty-four years of age, he was invited to become president of an academy then projected at Genoa; but, declining this honour, he was, in the following year, appointed professor of mathematics at St Petersburg. In consequence of the state of his health, however, he returned to Basel in 1733; where he was appointed professor of anatomy and botany, and afterwards of experimental and speculative philosophy. In the labours of this office he spent the remaining years of his life. He had previously published some medical and botanical dissertations, besides his *Exercitationes quaedam Mathematicæ*, containing a solution of the differential equation proposed by Riccati and now known by his name. In 1738 appeared his *Hydrodynamica*, in which the equilibrium, the pressure, the reaction, and varied velocities of fluids are considered both theoretically and practically. One of these problems, illustrated by experiment, deals with an ingenious mode of propelling vessels by the reaction of water ejected from the stern. Some of his experiments on this subject were performed before Maupertuis and Clairaut, whom the fame of the Bernoullis had attracted to Basel. With a success equalled only by Euler, Daniel Bernoulli gained or shared no less than ten prizes of the Academy of Sciences of Paris. The first, for a memoir on the construction of a clepsydra for measuring time exactly at sea, he gained at the age of twenty-four; the second, for one on the physical cause of the inclination of the planetary orbits, he divided with his father; and the third, for a communication on the tides, he shared with Euler, MacLaurin, and another competitor. The problem of vibrating cords, which had been some time before resolved by Taylor and D'Alembert, became the subject of a long discussion conducted in a generous spirit between Bernoulli and his friend Euler. In one of his early investigations he gave an ingenious though indirect demonstration of the problem of the parallelogram of forces. His labours in the decline of life were chiefly directed to the doctrine of probabilities in reference to practical purposes, and in particular to economical subjects, as, for example, to inoculation, and to the duration of married life in the two sexes, as well as to the relative proportion of male and female births. He retained his usual vigour of understanding till near the age of eighty, when his nephew James relieved him of his public duties. He was afflicted with asthma, and his retirement was relieved only by the society of a few chosen friends. In the spring of 1782, after some days' illness, he died, like his father, in the repose of sleep. Excluded by his professional character from the councils of the republic, he nevertheless received all the deference and honour due to a first magistrate. He was wont to mention the following as the two incidents in his life which had afforded him the greatest pleasure,—that a stranger, whom he had met as a travelling companion in his youth, made to his declaration "I am Daniel Bernoulli" the incredulous and mocking reply, "And I am Isaac Newton;" and that, while entertaining König and other guests, he solved without rising from table a problem which that mathematician had submitted as difficult and lengthy.

Like his father, he was a member of almost every learned society of Europe, and he succeeded him as foreign associate of the Academy of Paris. Several of his investigations are contained in the earlier volumes of the *St*

Petersburg Memoirs; and his separately published works are—(1.) *Dissertatio Inaugur. Phys. Med. de Respiratione*, Basl., 1721, 4to; (2.) *Positiones Anatomico-Botanicæ*, Basl., 1721, 4to; (3.) *Exercitationes quædam Mathematicæ*, Venetiis, 1724, 4to; (4.) *Hydrodynamica*, Argentorati, 1738, 4to.

V. JOHN BERNOULLI, the youngest of the three sons of John Bernoulli, was born at Basl on the 18th May 1710. He studied law and mathematics, and, after travelling in France, was for five years professor of eloquence in the university of his native city. On the death of his father he succeeded him as professor of mathematics. He was thrice a successful competitor for the prizes of the Academy of Sciences of Paris. His prize subjects were, the capstan, the propagation of light, and the magnet. He enjoyed the friendship of Maupertuis, who died under his roof while on his way to Berlin. He himself died in 1790. His two sons, John and James, are the last noted mathematicians of the family.

VI. NICHOLAS BERNOULLI, cousin of the three preceding, and son of Nicholas Bernoulli, one of the senators of Basl, was born in that city on the 10th October 1687. He visited England, where he was kindly received by Newton and Halley (*Com. Phil.* ep. 199), held for a time the mathematical chair at Padua, which Galileo had once filled, and was successively professor of logic and of law at Basl, where he died on the 29th of November 1759. He was editor of the *Aræ Conjectandi* of his uncle James. His own works are contained in the *Acta Eruditorum*, the *Giornale de' Letterati d'Italia*, and the *Commercium Philoſophicum*.

VII. JOHN BERNOULLI, grandson of the first John Bernoulli, and son of the second of that name, was born at Basl on the 4th December 1744. He studied at Basl and at Neuchâtel, and when thirteen years of age took the degree of doctor in philosophy. At nineteen he was appointed astronomer royal of Berlin. Some years after, he visited Germany, France, and England, and subsequently Italy, Russia, and Poland. On his return to Berlin he was appointed director of the mathematical department of the academy. Here he died on the 10th July 1807. His writings consist of travels and astronomical, geographical, and mathematical works. In 1774 he published a French translation of Euler's *Elements of Algebra*. He contributed several papers to the Academy of Berlin.

VIII. JAMES BERNOULLI, younger brother of the preceding, and the second of this name, was born at Basl on the 17th October 1759. Having finished his literary studies, he was, according to custom, sent to Neuchâtel to learn French. On his return he studied law and took a degree. This study, however, did not check his hereditary taste for geometry. The early lessons which he had received from his father were continued by his uncle Daniel, and such was his progress in the exact sciences that at the age of twenty-one he was called to undertake the duties of the chair of experimental physics, which his uncle's advanced years rendered him unable to discharge. He afterwards accepted the situation of secretary to Count de Brenner, which afforded him an opportunity of seeing Germany and Italy. In Italy he formed a friendship with Lorgna, professor of mathematics at Verona, and one of the founders of the Italian society for the encouragement of the sciences. He was also made corresponding member of the Royal Society of Turin; and, while residing at Venice, he was, through the friendly representation of Füss, admitted into the Academy of St Petersburg. In 1788 he was named one of its mathematical professors. In the following year he married a daughter of Albert Euler, son of the illustrious Euler.

This marriage was soon tragically dissolved by the death of the husband, who was drowned while bathing in the Neva in July 1789. Several of his papers are contained in the first six volumes of *Nova Acta Acad. Scien. Imper. Petropol.*, in the *Acta Helvetica*, in the *Memoirs of the Academies of Berlin and Turin*, and in his brother John's publications. He also published separately some juridical and physical theses, and a German translation of *Mémoires de Philosophes de Merian*.

BEROSUS was a Chaldean priest who lived in the time of Alexander the Great and his immediate successors. He translated the history of his native country, Babylonia, into the Greek language, and dedicated the work to one of the Greek kings of Syria named Antiochus. His work is principally known through the fragments of Polyhistor and Apollodorus, two writers in the 1st century before the Christian era, who are quoted by Eusebius and Lyncellus.

The work of Berosus professed to commence with the creation of the universe, and the history was carried down to his own time. A few quotations at second or third hand, and the bare outlines of his system of chronology, are all that has been transmitted to us through the copyists of Berosus; but the close connection throughout between his story and the Bible, and the knowledge that he drew his information from the records of Babylonia, have always invested these fragments with great importance,—an importance which has been increased of late, since the discovery of several cuneiform inscriptions confirming different parts of his history.

The history of Berosus first described the chaos before the creation, presided over by the female Thalath or Omoroca (the chaotic sea), called Tiamat and Tisallat in the inscriptions; she was destroyed by Belus, and then the gods created the heavens and the earth. After this he gave the chronology of the Babylonian kingdom as follows:—

	Years.
10 kings before the flood.....	432,000.
86 kings after the flood.....	34,080 or 33,091.
8 Median kings.....	324, or 284, or 190.
11 other monarchs.....	.....(number lost, in margin 42.)
49 Chaldean kings.....	463.
9 Arabian kings.....	245.
45 other kings.....	628.
After these reigned in Chaldea, Pal.	

The later part of the scheme of Berosus is lost, but detached extracts are quoted by some ancient historians.

In comparing the notices of Berosus with the Babylonian and Assyrian inscriptions, considerable difficulty is met with on account of the deficient information on both sides. The absence of chronological landmarks in the inscriptions, and the doubts as to the length of the third and fourth periods of Berosus, are serious difficulties in the way of the chronology, but in the absence of more satisfactory information the list of Berosus must be taken as the framework of Babylonian chronology.

The first period of Berosus, reaching from the creation to the flood, is said to have included 10 reigns and 432,000 years. The last two of these names are the only ones found with any certainty in the cuneiform inscriptions,—these are Ubara-tutu and Adra-hasis, the Otiartes and Xisuthrus of Berosus. The deluge, which closed this period, is described in Berosus, and in the cuneiform inscriptions of the Izdubar legends.

The next period given by Berosus includes 86 kings, and a period of 34,080 or 33,091 years,—the number is uncertain, and certainly unhistorical. It is probable that the later sovereigns of this period were historical, and some of the names which are preserved are ordinary Babylonian compounds. Three names in a fragment of Baby-

lonian chronology appear to belong to this period,—these are Ilu-kassat, Mulagununna, Abilkisu, who are given as successive sovereigns; and there is another probable king of the period, Izdubar, who most likely represents the Biblical Nimrod. During this period the language and people of Babylonia are supposed to have been Turanian, and in round numbers it may be said to end about 2400 B.C.

About 2400 B.C., according to Berosus, Babylonia was overruled by a conquering tribe called by him "Medes." He has preserved in connection with this event the name of Zoroaster, and has given the dynasty 8 kings, the length of the period being placed variously at 234, 234, and 190 years. Where our authorities differ so much, we can only make shift with a round number, and say the period was probably about 200 years, from 2400 to 2200 B.C. There is one name in the inscriptions supposed to belong to this period,—that of Kudur-nanhundi, king of Elam, who conquered Babylonia about 2280 B.C. Nothing is known as to the race here called Medes by Berosus, but it is conjectured that they were Elamites.

The next period of Berosus included 11 kings, the duration of the dynasty not being preserved. In the margin we have the number 48 years, but nothing is known of the origin of this number, and it appears too small for 11 kings. Perhaps we may provisionally allow about 200 years for this dynasty, 2200 to 2000 B.C. Nothing is known of the race or names of the monarchs.

About 2000 B.C. commenced a period including, according to Berosus, 49 kings and 458 years. The kings are called Chaldean, and appear to correspond with a famous line of sovereigns reigning at the cities of Ur, Karrak, and Larsa, commencing with the reign of Uruk, king of Ur. The centre of Babylonian power in their time lay in the south of the country, and many of the well-known temples and other buildings in this region were raised during their dominion. One of the monarchs in this period bore the name of Sargon; he was very celebrated, and of him a story is related similar to that of the infancy of Moses. He is said to have been concealed by his mother in an ark and floated on the River Euphrates. This great period ended with the defeat of Rim-agu, king of Larsa, by Hammurabi, who established a new dynasty, and made Babylon the capital about 1550 B.C.

The dynasty founded by Hammurabi appears to be the Arabian line of Berosus, which lasted under 9 kings for 215 years. Many of the kings of this period are known from the inscriptions. They first had extensive relations with the Assyrians, and about 1300 B.C. Tugulti-ninip, king of Assyria, conquered Babylon, and expelled the last Arab monarch. From this time commenced the direct influence of Assyria in Babylonia, and the period of this dynasty is counted by Berosus as 526 years. It probably ended with the time of Pul, a great king and conqueror, about whose personality and date there is much difference of opinion.

The next epoch in Babylonian history is that of Nabonassar, whose era commenced 747 B.C. From his time the history of Babylonia presents a constant series of conquests by the Assyrians, and revolts against them by the Babylonians, down to the time of Nabopolassar, who, after quelling a revolt in Babylonia, was made ruler of the country by the king of Assyria, and afterwards revolting against his master took Nineveh in concert with the Medes.

Nebuchadnezzar, son of Nabopolassar, who ascended the throne of Babylon 605 B.C., was one of the most celebrated kings in history, and is mentioned at length by Berosus, who then notices the revolutions at Babylon until the taking of the city by Cyrus 539 B.C.

The history of Berosus continued down to the conquest of Alexander the Great, and the reign of his patron Antiochus.

The writings and notices of Berosus were collected and published in Germany by Richter in 1825, and in England by Cory, in his *Ancient Fragments*. Later and excellent extracts and notices have been given by Canon Rawlinson and M. Lenormant, while the chronology of Berosus has exercised the ingenuity of Brandis, Oppert, Lenormant, Rawlinson, Hincks, and many other scholars. There is, however, no probability that any published system has correctly restored the dates of Berosus; the materials are at present insufficient for such a work. (G. A.)

BERRI, CHARLES FERDINAND, DUC DE, younger son of Charles X. of France, was born at Versailles on the 24th Jan. 1778. With his father, then Comte d'Artois, he had to leave France, and for several years served in the army of Condé. He afterwards joined the Russian army, and in 1801 took up his residence in England, where he remained for thirteen years. During that time he married an English lady, by whom he had two children. The marriage was cancelled for political reasons in 1814, when the duke set out for France. His frank, open manners gained him some favour with his sickle countrymen, which was increased by his marriage in 1816 with the Princess Caroline Ferdinande Louise of Naples. On the 13th of February 1820 he was mortally wounded, when leaving the opera-house with his wife, by a man named Louvel. Seven months after his death the duchess gave birth to a son, who received the title of duke of Bordeaux. She was compelled to follow Charles X. in his retirement from France after July 1830, but it was with the resolution of returning speedily and making an attempt to secure the throne for her son. In April 1832 she landed near Marseilles, but receiving no support, was compelled to make her way towards the ever-loyal districts of La Vendée and Bretagne. Her followers, however, were defeated, and after much suffering, she was betrayed to the Government and imprisoned in the castle of Blaye. Here she gave birth to a son, the fruit of a secret marriage contracted with an Italian nobleman, son of the Marchese Lucchesi Palli. The announcement of this marriage at once deprived the duchess of the sympathies of her supporters. She was no longer an object of fear to the French Government, who released her in June 1833. She set sail for Sicily, and from that time till her death in April 1870 lived a retired life with her husband and his relatives.

BERRYER, PIERRE ANTOINE, a French advocate and parliamentary orator, was born at Paris, January 4, 1790, in the midst of the agitating events of the first year of the great Revolution. Berryer's father was an eminent advocate and parliamentary counsellor. The son was educated at the Collège de Juilly, on leaving which he adopted, in deference to his father's wishes, the profession of the law; but his own leaning at that time was to the church. After completing the usual course of professional studies, he was admitted advocate in 1811, and in the same year he married. In the great conflict of the period between Napoleon I. and the Bourbons, Berryer, like his father, was an ardent Legitimist; and in the spring of 1815, at the opening of the campaign of the Hundred Days, he followed Louis XVIII. to Ghent as a volunteer. After the second Restoration he distinguished himself as a courageous advocate of moderation in the treatment of the military adherents of the emperor. He was engaged, in conjunction with his father and Dupin, in the unsuccessful defence of Marshal Ney before the Chamber of Peers; and he undertook alone the defence of General Cambronne and General Debelle, procuring the acquittal of the former and the pardon of the latter. Proceedings were soon after com-



menced against him for some assertions in one of his speeches, but he escaped with nothing more severe than a censure by the Council of Advocates. By this time he had a very large business as advocate, and was engaged on behalf of journalists in many press prosecutions. He stood forward with a noble resolution to maintain the freedom of the press, and severely censured the rigorous measures of the police department. In 1830, not long before the fall of Charles X., Berryer was elected a member of the Chamber of Deputies. He appeared there as the champion of the king, and encouraged him in his tyrannical course. After the Revolution of July, when the Legitimists withdrew in a body, Berryer alone retained his seat as deputy; and though avowedly the friend of the deposed king, he took an independent course, not making himself an unscrupulous partizan, but guided in his advocacy or his opposition by reason and prudence. He was one of the influential men who resisted, but unsuccessfully, the abolition of the hereditary peerage. He advocated trial by jury in press prosecutions, the extension of municipal franchises, and other liberal measures. In May 1832 he hastened from Paris to see the duchess of Berri on her landing in the south of France for the purpose of organizing an insurrection in favour of her son, the duke of Bordeaux, since known as the count of Chambord. Berryer attempted to turn her from her purpose; and failing in this he set out for Switzerland. He was, however, arrested, imprisoned, and brought to trial as one of the insurgents. He was immediately acquitted. In the following year he pleaded for the liberation of the countess; made a memorable speech in defence of Chateaubriand, who was prosecuted for his violent attacks on the Government of Louis Philippe; and undertook the defence of several Legitimist journalists. In 1834 he defended two deputies in a Government prosecution for libel, and the same year opposed the passing of a new rigorous law against political and other associations. Among the more noteworthy events of his subsequent career were his defence of Louis Napoleon after the ridiculous affair of Boulogne, in 1840, and a visit to England in December 1843, for the purpose of formally acknowledging the pretender, the duke of Bordeaux, then living in London, as Henry V., and lawful king of France. This proceeding brought on him the censure of M. Guizot, then first minister of Louis Philippe. Berryer was an active member of the National Assembly convoked after the Revolution of February 1848, again visited the pretender, then at Wiesbaden, and still fought in the old cause. This long parliamentary career was closed by a courageous protest against the *coup d'état* of December 2, 1851. After a lapse of twelve years, however, he appeared once more in his forsaken field as a deputy to the Corps Législatif. Meanwhile he had been a diligent promoter of the much talked of fusion of the two branches of the Bourbon family, and had distinguished himself at the bar by great speeches on the trial of Montalembert in 1858, and in the civil proceedings set on foot by M. Patterson against Jerome Bonaparte in 1860. Berryer was elected member of the French Academy in 1854. A visit paid by this famous orator to Lord Brougham in 1865 was made the occasion of a banquet given in his honour by the benchers of the Temple and of Lincoln's Inn. In November 1868 he was removed by his own desire from Paris to his country seat at Angerville, and there he died on the 29th of the same month.

BERTHOLLET, CLAUDE LOUIS, one of the most distinguished chemists of the French school, was born at Talloire, near Annecy, in Savoy, in 1748. He studied first at Chambéry, and subsequently at Turin, where he took his degree as a physician. In 1772 he settled at Paris, and soon became the medical attendant of Philip,

duke of Orleans. By the publication of a volume of chemical essays, he gained such reputation that he was admitted in 1781 into the Académie des Sciences. He was appointed Government superintendent of the establishment for the improvement of dyeing; and in 1791 he published his essay *Sur la Teinture*, a work that first systematized and chemically explained the principles of the art. It was translated into English by Dr William Hamilton, 1794. Berthollet early adopted the chemical views of Lavoisier, and took part with him in the formation of a new system of chemical nomenclature. He confirmed and extended the discoveries of Priestley on ammonia, discovered fulminating silver, and greatly extended our knowledge of the dephlogisticated marine acid of Scheele, for which the name of oxymuriatic acid was then proposed, and which is now termed chlorine. It was he who in 1786 first proposed to apply it to bleaching. He discovered the remarkable salt now called chlorate of potash; and we owe to him also an excellent essay on the chemical constitution of soaps. Berthollet's contributions to chemistry are scattered through the pages of the *Journal de Physique*, *Annales de Chimie*, *Mémoires de l'Institut*, and *Mémoires d'Arcueil*. At the commencement of the French Revolution the scarcity of saltpetre for the manufacture of gunpowder was much felt; and Berthollet was placed at the head of a commission for improving the processes for obtaining and purifying this important product within the territory of France. Soon afterwards we find him one of a commission for improving the processes in the smelting of iron, and converting it into steel. In 1792 he was appointed a director of the mint, and in 1794 he became a member of the committee on agriculture and the arts; while he filled the office of teacher of chemistry in the Polytechnic and Normal Schools of Paris, and took an active part in the remodeling of the National Institute in 1795. In the following year Berthollet and Monge were appointed heads of a commission to select in Italy the choicest specimens of ancient and modern art, for the national galleries of Paris. In 1798 Berthollet accompanied General Bonaparte to Egypt. On the overthrow of the Directory he was made a senator and a grand officer of the Legion of Honour. Under the empire he was created a count, and he sat as a peer on the restoration of the Bourbons. His last work was his curious essay on *Chemical Statics* (1803), in which he controverted the views of Bergman. Berthollet was a man of great modesty and unostentatious manners. For some years he lived retired at Arcueil, especially after the misconduct and suicide of his only son. He died at Paris of a painful malady bravely borne, November 6, 1822.

BERTHOUD, FERDINAND, a celebrated Swiss chronometer-maker, was born in Neufchâtel. The date of his birth is variously given as 1725, 1727, and 1729. His father was an architect, and the son was intended for the church; but, showing a taste for mechanics, he was placed under an experienced workman to be instructed in clock and watch making, and was afterwards sent to Paris to improve himself in the knowledge and practice of the art. He settled in Paris in 1745, and applied himself to the making of chronometers, an art which was then in its infancy. He soon attained distinction for the excellence of his workmanship and the accuracy of his chronometers. Fleurieu and Borda, by order of the French Government, made a voyage from La Rochelle to the West Indies and Newfoundland for the purpose of testing them, and they found that they gave the longitude with an error of only a quarter of a degree, after a cruise of six weeks. Satisfactory results were also obtained in the expedition of Verdun, Borda, and Pingré, which was appointed to try these chronometers and those of his only rival, Le Roy. Sully,

an English watchmaker established in Paris, was the first who in that city attempted the construction of chronometers for finding the longitude; and this he did in 1724. In 1736 the chronometers of the English artist Harrison were tried at sea. In France, however, there were no chronometer-makers of note after Sully, till Pierre le Roy and Ferdinand Berthoud, between whom there was some discussion about the priority of their discoveries and improvements. Ferdinand Berthoud's chronometers were long the most esteemed of any in France. Louis Berthoud, his nephew and successor, introduced some improvements, and made chronometers of a smaller size and therefore more portable. Berthoud was a member of the French Institute, a fellow of the Royal Society of London, and a member of the Legion of Honour. He was regular in his habits, and retained the use of his faculties to the last. He died of hydrothorax, at his country house, in the valley of Montmorency, in 1807, aged about eighty. The principal of his published works are *Essais sur l'Horlogerie*, 2d edit., 1786, 2 vols. 4to; two Tracts on Chronometers, 1773; *De la Méasure du Temps*, 1787, 4to; *Les Longitudes par la Méasure du Temps*, 1776, 4to; a Tract on Chronometers, 1782, 4to; *Histoire de la Méasure du Temps par les Horloges*, 1803, 2 vols. 4to; *L'Art de conduire et de régler les Pendules et les Montres*, 1760, 12mo. The tract last named, containing directions suited to general readers for regulating clocks and watches, passed through several editions.

**BERTINORO** (identified, on conjecture, with the ancient *Forum Druentinarum*), a city of Italy, in the province of Emilia and district of Forlì, the seat of the bishop of the united dioceses of Forlimpopoli and Bertinoro. It stands on a hill, below which the River Ronco flows, and is celebrated for the excellence of its wine. Population, 6540. Long. 12° 2' 30" E, lat. 44° 8' 34" N.

**BERWICK, JAMES FITZJAMES, DUKE OF**, marshal and peer of France, was a natural son of James, duke of York, afterwards James II. of England, by Arabella Churchill, sister of the great duke of Marlborough. He was born at Moulins, August 21, 1670. He received his education in France, studying successively at Juilly, at the College of Plessis, and at the College of Flèche. At the age of fifteen, his father having succeeded to the throne, he was sent to learn the business of a soldier under the famous general of the empire, Charles of Lorraine. He served his first campaigns in Hungary, and was present at the siege of Buda and the battle of Mohacz. In 1687 he returned to England, was made a Knight of the Garter, and created duke of Berwick. After the Revolution he served under James II. in the campaign in Ireland, was in one engagement severely wounded, and was present at the battle of the Boyne. For a short time he was left in Ireland as commander-in-chief, but his youth and inexperience unfitted him for the post, and he was a mere puppet in stronger hands. In 1692 he was recalled to France, and took service in the French army. He fought under Marshal Luxembourg in Flanders, took part in the battles of Steinker and Landen (Neerwinden), and was taken prisoner at the latter. He was, however, immediately exchanged for the duke of Ormond, and afterwards he served under Villeroi. In 1696 the duke of Berwick took a prominent part in a plot for a Jacobite insurrection, but the scheme came to nothing. In 1702 he served under the duke of Burgundy, and in the following year became naturalized as a Frenchman. In 1704 he first took command of the French army in Spain. So highly was he now esteemed for his courage, abilities, and integrity, that all parties were anxious to have him on their side (*Éloge*, by Montesquieu). From Spain he was recalled to take the command against the Camisards in Languedoc, and when on this expedition he is said to have carried out

with remorseless rigour the orders which he received from Versailles. About this time he was created marshal of France. He was then sent again to Spain to retrieve the affairs of that kingdom, and to prop up the tottering throne. In April 1707 he won the great victory of Almaná, an Englishman at the head of a French army, over the earl of Galway (comte de Buigny), a Frenchman at the head of an English army. The victory established Philip V. on the throne of Spain, although neither he nor his rival, the archduke, was present at the battle. Berwick was made a peer of France and grandee of Spain. In 1708 he became commander-in-chief of the armies of France in Spain, in Flanders, on the Rhine, and on the Moselle. Through the four following years he gained fresh laurels by his masterly defence of Dauphiné, and in 1713 he returned to Spain and took Barcelona. Three years later he was appointed military governor of the province of Guienne. In 1718 he found himself under the necessity of once more entering Spain with an army; and this time he had to fight against Philip V., the king who owed chiefly to his courage and skill the safety of his throne. One of the marshal's sons, known as duke of Liria, was settled in Spain, and was counselled by his father not to shrink from doing his duty and fighting for his sovereign. Many years of peace followed this campaign, and Marshal Berwick was not again called to serve in the field till 1733. He advised and conducted in 1734 the siege of Philipsburg on the Rhine, and while the siege was going on was killed by a cannon-shot, June 12 of that year. Cool, self-possessed, and cautious as a general, Marshal Berwick was at the same time not wanting in audacity and swiftness of action in a real crisis. He was careful of the lives of his men, and was also a rigid disciplinarian. Lord Bolingbroke pronounced him the best great man that ever existed. Montesquieu said, "In the works of Plutarch I have seen at a distance what great men were; in Marshal Berwick I have seen what they are." He married in 1695 a daughter of the earl of Clanricarde, by whom he had the son already mentioned. He married a second wife in 1699, by whom he had another son, known as Marshal Fitz-James. The *Mémoires* of Marshal Berwick, revised, annotated, and continued by the Abbé Hoak, were published by the marshal's grandson in 1778. An untrustworthy compilation bearing the same title had been published about forty years earlier.

**BERWICK-UPON-TWEED**, a seaport town and municipal and parliamentary borough, at the mouth of the Tweed, in 55° 46' N. lat. and 1° 59' W. long., 300 miles N. by W. from London, and 47 E.S.E. from Edinburgh. Berwick proper is built chiefly on the declivity and flat summit of an elevation rising abruptly from the north side of the river. The liberties of the borough, commonly called "Berwick Bounds," containing an area of nearly eight square miles, extend to the N. and W., and form the N.E. extremity of England. The borough also includes (since 1835) the townships of Tweedmouth and Spittal on the south side of the river,—the latter a fishing and watering place on the coast, the former a manufacturing village connected with Berwick by a bridge. The town has a pleasing appearance from the neighbouring heights, especially at full tide,—sea and river, ramparts, bridges and pier, buildings ancient and modern, and the red-tiled roofs of the houses contributing to the view. The principal streets are wide, well built, and well paved, there being a remarkable absence, in so ancient a town, of narrow streets and old houses.

Berwick is one of the few remaining walled towns in the United Kingdom. The present ramparts were built in the reign of Elizabeth. To the north and east they are formed of earth faced with stone; bastions with cavaliers as

placed at intervals, and a ditch, now dry, extends to the river. Fronting the river are four-gun and six-gun batteries defending the entrance to the harbour, and a twenty-two-gun battery commanding the south side. These ramparts which are perforated by five gateways, are

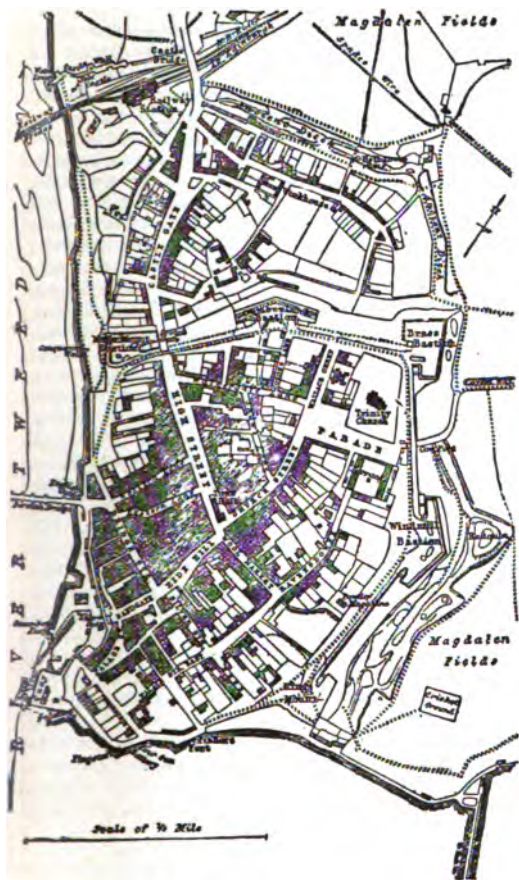

Plan of Berwick-upon-Tweed.

generally in good repair, but since 1822 have been destitute of guns save for volunteer practice. The circuit is about 1 mile 3 furlongs; that of the older walls was more than 2 miles. The ruins of the latter, built by Edward I., and also surrounded by a ditch, enclose the suburbs of Castlegate, and the Greens,—the fishermen's quarter. The Bell Tower, from which alarms were given, and which is least dilapidated, has been recently secured from further decay. Between the extremity of these old walls and the Tweed are the remains of the old castle, which was allowed to become a ruin after the union of the crowns. There are no traces of the churches, monasteries, or other ancient buildings of the town. The barracks, built in 1719, accommodate nearly 600 men; but they are now occupied only by militia, and the governor's house has become a private dwelling.

The chief public buildings are the town-hall, finished in



Arms of Berwick.

1760, a stately building, surmounted by a spire 150 feet high, which contains a peal of eight bells; the new jail, erected in 1849; the corn exchange, which is the principal public hall, opened in 1858; a new infirmary; two assembly rooms; Masonic and Good Templar halls. The parish church is a plain Gothic building, without steeple, of the time of Cromwell. It was thoroughly and tastefully renovated in 1855. The patronage belongs to the dean and chapter of Durham. A week-day lectureship is in the patronage of the Mercers' Company, London. There are also in the borough, including Tweedmouth and Spittal, three other churches connected with the Church of England, three with the Church of Scotland, four United Presbyterian, two English Presbyterian, two Methodist, one Baptist, and one Roman Catholic. The only church building worthy of notice is Wallace Green United Presbyterian Church, opened in 1859. New cemeteries were opened at Berwick in 1855, and at Tweedmouth in 1858. The town is well supplied with educational institutions; and a local museum was established in 1867, where lectures are delivered during the winter. The town and suburbs have four public reading-rooms, and three newspapers are published. Two bridges connect the town with the south side of the Tweed. The older, which is very substantial, was finished in 1634, having taken twenty-four years in building. It has fifteen arches, and is 924 feet long, but only 17 feet wide. The other, situated a quarter of a mile up the river, is a magnificent railway viaduct, 126 feet high, with twenty-eight arches, which extends from the railway station—a castellated building on part of the site of the old castle—to a considerable distance beyond the river. This bridge was opened by Queen Victoria in 1850.

The Tweed is navigable as far as the old bridge, and the tide flows seven miles further. The entrance to the harbour has been improved and protected by a stone pier, built about sixty years ago, which stretches half a mile S.E. from the north bank of the river's mouth, and has at the extremity a lighthouse with two fixed lights. The depth of water at the bar is 17 feet at ordinary tides, 22 feet at spring tides, but the channel is narrow, a large rocky portion of the harbour on the north side being dry at low water. A long-felt want is now being supplied by the construction of a dock, which was begun at Tweedmouth, September 1873. The number of vessels belonging to the port (1875) is 25 (tonnage, 1459). There entered in 1873, 422 (tonnage, 35,049), and there cleared 424 (tonnage, 35,252). The principal exports are grain, meal, herrings, burnt ore, metal castings, manures; the imports are bones and bone-ash, manure stuffs, linseed, salt, timber, pig-iron. The sea-fisheries employ 230 boats in white fishing, 294 in herring fishing, and 52 in both. Berwick, which has long been famous for its salmon fisheries, is the headquarters of the Fishing Company, which occupies most of the stations on the neighbouring coast and for some miles up the river. The fish are mostly sent to the London market. There is an annual fair held here in the end of May, and the weekly market on Saturday. There are four banking establishments; and, on the whole, the trade of the town is increasing.

The ancient charter of the borough of Berwick was confirmed by various sovereigns from Edward I. to James I., who added new officers and privileges, but especially gifted to the burgesses all the lands within the liberties which were not private property. These lands, amounting to 3077 acres, or two-thirds of the whole, are partly divided into farms, partly into meadows occupied or let by the resident freemen and freemen's widows. The annual value of a meadow, seniority determining the allocation, ranges at present from £11, 5s. to £2, 9s. 3d. The roll of freemen contains about 1000, of whom 368 are

resident. The total rental of the corporation's property is now about £10,800. Since the Municipal Reform Act, 1835, the borough has been governed by six aldermen and eighteen councillors; and in 1842 "the power of life and death" was removed from the Quarter Sessions to the Newcastle Assizes. The custom of specially mentioning Berwick-on-Tweed after Wales, though abandoned in Acts of Parliament, is still retained in certain proclamations. The title of "county in itself" also helps to recall its ancient history. It is the seat of a Poor Law Union, and the rateable value of the borough (1875) is £53,195. Berwick has sent two members to the English parliament since the reign of Mary. The registered electors number 1285, of whom 368 may vote as freemen, about 200 being doubly qualified. Population in 1871, 8731, or, including the conjoined townships (Tweedmouth, 2809, and Spittal, 1742), 13,282.

Of the origin or early history of Berwick nothing is known. It probably sprang into importance during the long struggle between the Scots and Saxons for the possession of Lothian and the Merse. Egfrid, king of Northumbria, seeking to extend his boundary beyond the Forth, was routed at Dunnichen, 685, and driven back to the Tweed. But it was not until the battle of Carham, 1018, that the latter river was finally secured as the boundary, and Berwick obtained the frontier position to which it owes its fame. It seems rapidly to have grown in size, wealth, and influence. Its name occurs as a royal burgh in the reign of Alexander I., along with Edinburgh, Roxburgh, and Stirling, and with them, from David I., it elected the tribunal which from their number was called the "Court of the Four Burghs." The castle of Berwick was one of the strongholds given up to Henry II. of England to be security for the homage due by William the Lion as the price of his liberty, but it was restored with the others by Richard Cœur-de-Lion in 1189. At Berwick took place several of the conferences held between Edward I. and the competitors for the Scottish crown, and his decision in favour of Balliol was given in the castle, Nov. 1292. Four years later Edward marched north to punish his rebellious vassal, and began his invasion by an attack upon the town which was at once the key of the kingdom and its commercial capital. The English king, familiar with the place, and infuriated by the repulse of his fleet in the river, led the land attack in person. Being very slightly fortified the town was speedily stormed, and no mercy was shown to the inhabitants. One memorable incident is recounted. A company of trading Flemings held out against the besiegers in their fortified building, the Red Hall, until it was set on fire. They were bound by their charter to defend it to the last extremity against the English, and they perished in the flames. Berwick never recovered commercially from the massacre and pillage of this terrible Good Friday. Its efforts again to rise were hindered by the ever-renewed Border warfare, and it gradually sunk to the rank of an ordinary market-town.

On Edward's return from his victorious march through Scotland, he determined to make the town impregnable with stone walls, but before his commands could be accomplished it was recaptured by the Scots as a consequence of the English defeat at Stirling Bridge. On Edward's approach the following year, however, the Scots retired, and during the remainder of his reign it continued in the hands of the English. Here, in 1805, one quarter of Wallace's body was exposed, and shortly afterwards the countess of Buchan was suspended in a cage from one of the castle towers, as a punishment for courageously performing the privilege of her family by placing the crown on King Robert Bruce at Bona. Edward II. spent the winter of 1810 at Berwick after an ineffectual invasion of Scotland. Here, too, on June 11, 1814, the great English army assembled which was defeated a fortnight later at Bannockburn. In 1818 the town, now well fortified, was captured by Bruce, through the help of one of the garrison; a siege by Edward, which followed, rendered famous by the engines employed both in the river and land attacks, was not successful. It remained in the hands of the Scots till 1833, when it was besieged by Edward III., and the hope of relief by the Scottish army being disappointed by their defeat at Halidon Hill, about 2 miles from Berwick, the town and castle were immediately, according to agreement, delivered up to the English king. The next 180 years saw Berwick occasionally attacked by the Scots, and sometimes with success, but they held it only for short periods until 1461, when Henry VI., in gratitude for refuge after the battle of Towton, made it over to them. In 1482, during the disputes between James III. and his nobles, it surrendered to the English army, and was never retaken by the Scots. Henceforward it occupied in Scotland, in relation to England, the position for long of Calais in France—an important stronghold, the sole remnant of wide-spread conquest. This position

explains the possession by Berwick, until the union of the crowns, of a civil and military establishment (with lord-chancellor, lord-chamberlain, Domesday Book, governors of town and castle, &c.) resembling that of a small kingdom. It was that appointed by Edward I. for all Scotland, and was ready to expand, as it had been compelled to contract its sphere, should more territory be again acquired north of the Tweed.

BERWICKSHIRE, a maritime county of Scotland, forming its S.E. extremity, bounded N.E. by the German Ocean, N. by Haddington, W. by Midlothian, S.W. by Roxburgh, S. by the Tweed, which separates it from Northumberland, and S.E. by the liberties of the town of Berwick. Its greatest length from E. to W. is 31½ miles; its greatest breadth 19½; area about 464 square miles, or 297,161 acres. It is naturally divided into three districts, *Lauderdale*, or the valley of the Leader, in the W.; *Lammermuir*, the upland district occupied by the hills of that name, in the N.; and the *Merse* (probably a corruption of "March" or borderland), the largest district, occupying the S.E. of the county. The Lammermuirs are a range of round-backed hills, whose average height is about 1000 feet, while the highest summit, Says Law, reaches 1753 feet. From these hills the Merse stretches to the S. and E., and is a comparatively level tract of country, traversed, however, from N.W. to S.E. by distinct parallel ridges. The course is lofty, rocky, and precipitous, broken by ravines, and not accessible, except at Eyemouth harbour, for small vessels, and at one or two other places for fishing-boats. St Abb's Head, a peninsular promontory with a lighthouse upon it, rises to nearly 300 feet. The Eye is the only river of the county which falls into the sea. The others—the Leader, the Eden, the Leet, and the Whiteadder with its tributaries, the Blackadder and the Dye—all flow into the Tweed. Of these the largest and most important is the Whiteadder, which has its source on the East-Lothian side of the Lammermuirs, and, following a sinuous course of 35 miles, falls into the Tweed within the "Bounds" of Berwick. The climate of Berwickshire is chiefly influenced by its maritime position. The winter is seldom severe in the lowland districts; but spring is generally a trying season on account of the east winds, which often continue into summer. Drainage has remedied the former excessive humidity, and the climate is now excellent, in relation both to the health of the inhabitants and to the growth of vegetation.

Berwickshire, geologically, consists of Silurian rocks in the hilly region, Devonian or Old Red Sandstone in the south-west, and carboniferous limestone in the Merse. Large masses of porphyritic and trap rock occasionally occur, of which St Abb's Head is an example. The sea-cliff to the north-west of the mouth of the Eye is formed of conglomerate or pudding-stone. There is an interesting and somewhat famous geological appearance at a point called Siocar, near Cockburnspath, where the sea has laid open very plainly the junction of the primary and secondary strata.

The soils of Berwickshire are extremely various. On the same farm a great diversity may be found. Along the rivers is a deep rich loam, resting on gravel or clay, chiefly the former. The less valuable clay soil of the Merse has been much improved by the effective system of drainage which is everywhere carried out. The more sandy and gravelly soils are suitable for the turnip crops, which are a marked agricultural feature of the county. To these soils the landlords and tenants of Berwickshire have applied themselves with such intelligence, mutual good-will, liberality, and spirit, that the county now stands in the first rank in regard to agriculture. The farms are large, and are commonly held by a nineteen years' lease. Nowhere is farming conducted more scientifically or with better success. According to the agricultural returns for 1874, the total acreage under all kinds of crops, bare fallow, and grass,

was 192,138, or more than three-fifths of the entire area. Of this, 63,526 acres were under corn crops, 34,155 under green crops, 56,940 under clover and grasses, and 36,858 permanent pasture, meadow, or grass not broken up in rotation (exclusive of heath or mountain land). The average extent of land occupied by each occupant was 194 acres. Wheat was grown on 6373 acres; barley or bere, on 21,469; oats, on 33,130; potatoes, on 2593; turnips and swedes, on 30,345. Of live stock there were 5356 horses, 16,979 cattle, 286,578 sheep, 4527 pigs. Though about the twentieth in size of the Scottish counties, Berwickshire stands fifth in the number of acres under corn crops, fifth also in green crops, and ninth in the number of sheep. The farm-buildings are convenient and well built. These include cottages for the farm-labourers, or *kinds*, and their families,—the ordinary staff consisting of a steward, a shepherd, and a number of ploughmen proportionate to the size of the farm. The farm-labourers, who are physically well developed, are as a whole a frugal, industrious, intelligent race. They are somewhat migratory in their habits, being too ready to move from place to place year after year. This feature in their character, which they may have by inheritance as *Borderers*, has admirably fitted them for colonial life, to which the lack of employment in mining or manufactures in the county has largely drawn the surplus population.

The minerals of Berwickshire are insignificant. Coal, copper ore, and ironstone exist in such small quantities that attempts to work them have been abandoned; and the limestone is at too great a distance from a coal district to warrant competition with the adjoining counties. The Tweed salmon fisheries are productive of an important trade, and are so subject to vicissitudes that much attention has been paid to them by means of legislative enactments. The lesser rivers of the Merse are held in high esteem by anglers. Besides Eyemouth there are three villages—Burnmouth, Coldingham Shore, and Cove—engaged in the sea-fisheries, which are of considerable and increasing value. Cod, haddock, herring, ling, lobsters, and crabs are the principal produce. Berwickshire cannot boast of many manufactures. Earlstoun sends out gingham and woollen cloths. At Cumledge, also, on the Whiteadder, there is a factory for heavy woollen cloths; and four miles further down the river, at Chirside Bridge, is one of the largest paper mills in Scotland. The other manufactures are all connected with agriculture, such as distilleries, breweries, tanneries, &c. The trade is also mainly agricultural. Fairs are held at Dunse, Lauder, Coldstream, Greenlaw, and Oldhamstocks; but the sales of cattle and sheep are now mostly accomplished at the weekly or fortnightly auction marts at Repton, Dunse, and Earlstoun. The grain markets are held at Dunse and Earlstoun. Berwick, from which the county derives its name, is still its chief market-town. There is, however, no legal or fiscal connection between the county and the borough.

The early history of Berwickshire is to a great extent bound up with that of the ancient frontier town; from its position it also suffered much during the Border wars. The most noteworthy antiquities are Coldingham Priory in the E. and Dryburgh Abbey in the S.W. They were burnt in the same year, 1545, during the barbarous inroad of the English army under the earl of Hereford. About four miles N. from Coldingham are the ruins of Fast Castle ("The Wolf's Crag" of the *Bride of Lammermoor*), situated on a peninsular cliff, 120 feet by 60, and 70 feet above the sea. A little further north is the Pease or Peaths Bridge, built by Telford, in 1786, over the deep glen which forms the celebrated pass—of old one of the strongest natural defences of Scotland. Near it is Cockburnspath Tower, once a strong fortress, now in ruins. In the west of Berwickshire, besides Dryburgh, there are, at Earlstoun, the remains of the ancient

tower "The Rhymer's Castle," the traditional residence of Thomas Learmont, commonly called Thomas of Erildoun or Thomas the Rhymer. About a mile from Earlstoun is Cowdenknowes, on a hill above which grew the "bonnie broom" of the old song. None of it now remains, it having been gradually encroached upon by the plough, and the last of it killed by the severe frost of 1861-62. Hume Castle, the ancient seat of the Home family, also towards the west, has a most commanding view, and is itself visible from nearly every part of the county. Traces of Roman occupation and of ancient British settlements exist in various parts of the Merse. Edin's or Etin's Hall, on Cockburn Law, about four miles north of Dunse, still goes under the name of the Pech's or Pict's House. There are many large mansions throughout the county, the principal being Thirlestane Castle (earl of Lauderdale), Mertoun House (Lord Polwarth), Mellerstain and Lennel House (earl of Haddington), Nesbit (Lord Sinclair), Dunse Castle (Hay), Wedderburn and Paxton (Milne Home), Leea (Sir John Marjoribanks), Ladykirk (Baroness Marjoribanks), Ayton Castle (Mitchell Innes), Hirsal (earl of Home). The chief towns are Greenlaw, the county town, with a population of 823; Dunse, 2618; Lauder, 1046, a royal burgh, which unites with the Haddington group of burghs in returning a member to parliament; Coldstream, 1724; and Eyemouth, 2324, the only seaport of the county. There is one sheriff for the three border counties of Berwick, Roxburgh, and Selkirk, and a sheriff-substitute holds his court in Dunse. Justice of the Peace courts are held at Coldstream and at Ayton, and a burgh court at Lauder. The county is divided into thirty-one parishes, and it returns one member to parliament. Population of Berwickshire, 36,486—males, 17,414; females, 19,072.

The fauna and flora of Berwickshire have been carefully described by the late Dr George Johnston, and further information may be obtained regarding these from the *Transactions of the Berwickshire Naturalist's Club*.

BERYL, a mineral species which includes, in addition to what are ordinarily known as beryls, the aquamarine or precious beryl and the emerald. The similarity between the beryl and the emerald was pointed out by Pliny, and the only points of distinction are the green colour of the emerald and the somewhat superior hardness of the beryl. The colour of the emerald is generally believed to be due to the presence of a minute portion of oxide of chromium, although M. Lewy asserts, from analysis of Muso emeralds, that it is really owing to the presence of organic matter. Their composition is—

	Beryl.	Emerald.
Silica.....	87.00	68.50
Alumina.....	16.50	15.75
Glucina.....	14.50	12.50
Chromium oxide.....	0.00	0.30
Iron oxide.....	1.00	1.00
Lime.....	0.50	0.25

The metal glucinum, from its presence in the beryl, is sometimes termed beryllium. The beryl crystallizes in six-sided prisms with the crystals often deeply striated in a longitudinal direction; its hardness in the mineralogical scale is from 7.5 to 8, and its specific gravity from 2.67 to 2.732. Leaving out of account the emerald, the colours of the beryl range from blue through soft sea green to a pale honey yellow, and in some cases the stones are entirely colourless. The aquamarine is so named on account of its bluish green colour, "*qui viriditatem puri maris imitantur*" (Pliny, *N. H.*, xxxvii. 20). The chrysoberylus, chrysoprasus, and chrysolithus of ancient jewellery appear to some extent at least to have been names applied to different shades of beryl. The beryl was highly prized for use in jewellery by the Romans, by whom it was cut into six-sided prisms (*cylindri*) and mounted as ear-drops. Some of the

finest examples of ancient Greek and Roman gem engraving are found executed in beryl. "The grandest intaglio extant of the Roman period is upon an aquamarine of the extraordinary magnitude of  $2\frac{1}{2}$  by  $2\frac{1}{2}$  inches: the bust of Julia Titi signed by the artist ΕΥΘΑΟΟ ΕΠΟΙΕΙ. For nearly a thousand years it formed the knoop of a golden reliquary presented by Charlemagne to the abbey of St Denys, in which it was set with the convex back uppermost, being regarded as an invaluable emerald" (King's *Precious Stones, Gems, and Precious Metals*). The great abundance of aquamarine and other forms of beryl in modern times has very much depreciated its value for use in jewellery, but it is still set in bracelets, necklaces, &c., and used for seals. The finest aquamarine known is a large stone, in size and shape somewhat like a small calf's head, weighing 18 lb, the property of the emperor of Brazil. A beryl weighing 2900 lb and another of 1076 lb weight have been found at Gratton, New Hampshire, in the United States; but these gigantic stones are opaque, and of no value for jewellery. Beryl is found widely, disseminated, occurring, among other localities, in Siberia, Canjargam in Hindustan, Rio San Matteo in Brazil, Ehrenfriedersdorf in Saxony, and Schlackenwald in Bohemia. In the United Kingdom it occurs in the Mourne Mountains, county Down; in the neighbourhood of Killiney, county Dublin; in county Wicklow; in several places in Cornwall; and in Aberdeenshire in the granite of Babelaw (Davidsonite); besides occurring in the alluvium of the upper reaches of the Dee and Don. In the United States it is found in the states of New Hampshire, Maine, Massachusetts, Connecticut, and Pennsylvania.

BERZELIUS, JÖNS JAKOB, one of the most illustrious of modern chemists, was born on the 20th of August 1779, at a farm near Wåfversunda, in Östergötland, Sweden. At the age of nine he was left an orphan in the charge of his stepfather, A. Elmark of Ekoby, a learned and amiable man, gifted, too, it would seem, with some prophetic insight, for one day he said to the child, "Jakob, I think you will tread in the footsteps of Linnæus, or be another Cartouche!" From that day a desire for distinction as a man of science awoke in the child's breast. In 1793 Berzelius entered the gymnasium school at Linköping, where he made rapid progress. During his holidays, spent in the country, he met a man who instructed him in the elements of entomology, and thus gave a fresh impetus to his scientific proclivities. The latter soon developed into a passion, and under Hornstedt at Linköping progressed rapidly till he left the college in 1796, and proceeded to the University of Upsala. In 1798 he began to study chemistry under Professor Afselius; and although in those days the lectures were without practical experiments and extremely uninteresting, he became more and more absorbed in the study. In 1800 he was called to Stockholm as assistant to the royal physician, Dr Hedin, and his success as a practical chemist began. The Italian, Volta, had in 1800 invented the galvanic battery which bears his name; and Berzelius was one of the first persons in Europe to observe the greatness of this discovery. In 1802 he published a treatise on the subject. In 1803 he became professor of physics, and by his lectures rapidly founded a new, a rational school of physiology, and threw new light on many difficult points connected with the chemical and physical characteristics of animal life. In the same year he published his *Essay on the Division of Salts through Galvanism*, in which he propounds the electro-chemical theory, the honour of first laying down which is divided between Berzelius and Davy. In conjunction with Hisinger, Berzelius then published in numbers *Treatises on Physics, Chemistry, and Mineralogy*, a work of the greatest value for science. Honour after

honour was heaped upon him; in 1810 he was called to be a member of the Medical College of Sweden; in 1808 he was elected president of the Academy of Sciences. Two years later he brought out his famous treatise *On the Fixed Proportions and Weights of Atoms*. He then took up mineralogy with special ardour, and published his *Treatise on the Blowpipe*; he set up for himself a regularly graduated chemical system of minerals, and the value of this was felt to be so great that the Royal Society of London voted him its gold medal for it. After incessant labour he retired, in 1832, from his professorship at Stockholm, having never been connected as teacher with any of the universities. In 1842, while he was engaged in a chemical experiment, an explosion took place and he was much injured, but recovered and continued to work on till the close of his days. He died August 7, 1848. After Linnæus, his is considered to be the greatest name in science of which Sweden can boast.

BES, the name of an Egyptian god, apparently the same as that of the city Bessa. He is stated to have been worshipped and to have had an oracle at Abydos according to Ammianus Marcellinus,<sup>1</sup> and according to others at Antinoe or Antinopolis. The name *Bes* is found in Egyptian monuments attached to a god clad in a lion's skin, the head and skull of the animal covering his head and concealing his features; his legs are bowed like Ptah, and his whole appearance is grotesque, resembling in other respects the Greek Hercules. This god is represented at a later period in various attitudes and actions, in adoration to Harpocrates, styled his lord or master, playing on the tambourine, the triangular harp, and other musical instruments, brandishing swords, and at the Roman period armed in the paludamentum and holding a sword and buckler. Although supposed to be a form of Typhon he is quite distinct from Set, the ass or gryphon-headed god. For head attire Bes often wears a kind of cornuc surmounted by four or five feathers of the hawk. He does not appear among the deities of Egypt till about the 19th or 20th dynasty, and is apparently of foreign origin, being found on the coins of Gaulos, with Phœnician legends, as if belonging to that people and a form of Baal. He appears in the *Ritual* as the guardian of the 20th Pylon or doorway of the Aahlu or Elysian fields, with his mystical names. His head generally surmounts the little cippi of Harpocrates, and some texts ally him with the god Amen. A temple in Nubia, built by Tirhakah about 690 a.c., has its column in shape of this god. His figures and busts are common in Egyptian art of a later age, and individuals were called after him both in earlier and later times.<sup>2</sup>

BESANÇON, a city of France, capital of the department of Doubs, 45 miles E. of Dijon, on the River Doubs, which flows round it on three sides. It is well protected by strong fortifications and a citadel on an almost impregnable rock, 410 feet above the river. The town is in general well built, and has three main streets running from N. to S. The principal buildings are the Gothic cathedral of St Jean, a court-house, a town-hall, the Granville palace, the royal college, an arsenal, a large hospital, barracks, a theatre, a library of 300,000 volumes, a museum and picture gallery, and several handsome fountains. Among the numerous Roman remains are a triumphal arch erected in honour of Crispus Caesar, son of Constantine, a theatre, and an amphitheatre. Besançon is the see of an archbishop, has tribunals of primary jurisdiction and commerce, and is the head court for the departments of Doubs, Jura, and Haute Saône. It possesses also a university-academy, a diocesan seminary, a royal academy of science and

<sup>1</sup> *Ammian. Marcell.*, xix. 164; Jablonaki, *Panthe.*, v. c. 7; Wilkenson, *Manners and Customs*, vol. iv. p. 441.

<sup>2</sup> *Birch. Gallery of Antiquities*, p. 47.

belles-lettres, a lyceum, an antiquarian museum, a society of agriculture, and schools of medicine, artillery, and design, besides two deaf and dumb institutions. The chief branch of industry is the manufacture of watches and jewellery. There are also some considerable breweries and manufactories of carpets, porcelain, hardware, Seltzer-water, artificial flowers, &c. Besançon enjoys a good position for the commerce between France and Switzerland. Population in 1872, 39,868. Long. 5° 56' 26" E., lat. 47° 14' 12" N.

Besançon is a place of great antiquity. Under the name of *Vesontia*, it was, in the time of Cæsar, the chief town of the Sequani. Under the Roman emperors it was rich and prosperous, and Aurelian especially had a great liking for the place. Many of the streets still bear the old Roman names. It was frequently destroyed and rebuilt during the Middle Ages, and the present city stands twenty feet above the original level. In the 12th century it passed with the rest of Franche-Comté to the German empire, and was made a free city by Frederick I. In 1584, Granville, the minister of Charles V. became archbishop of the see, and afterwards founded a university in the town, which existed till the Revolution. By the treaty of Westphalia, Besançon was made over to Spain, and many traces of Spanish occupation still remain. In 1660 Louis XIV. besieged it in person, and it was assigned to France by the peace of Nimègue. In 1814 and 1815 it was invested and bombarded by the allies; and in the war of 1870-71 it formed an important position in the movements of the French army.

BEJKOW, BREYHARD VON, Baron, the Swedish dramatist, was born at Stockholm, April 19, 1796. Beskow's first book, *Poetical Efforts*, published in 1818, made a favourable impression with the public, and he wrote the prize poem for the Swedish Academy some years later. His dramas, however, are his chief claim to remembrance; the best are *Torkel Knutsson*, *Erik XIV.*, *Birger and his Race*, and *Gustavus Adolphus in Germany*. *Torkel Knutsson* is considered the finest drama that Swedish literature possesses. In the highest sense of the word, these are not, however, dramas at all, since they lack unity and fail in the development of character, but they are grandiose historical studies in a dramatic form. Beskow's poetry is over-decorated with phrases, and becomes the prey of sonorous antithesis. Besides lyrical and dramatic poetry, Baron von Beskow distinguished himself in history, philosophy, politics, and travels. In 1828 he was elected president of the Swedish Academy, and became an enthusiastic and liberal patron of national poetry and art. *Öfvenschläger* translated his dramas into Danish, and various persons rendered them into German. He died on the 17th of October 1868.

BESSARABIA, a government in the S.W. of European Russia, on the borders of Austria and the Danubian principalities, with an area, since the cessions of the Paris peace in 1856, of 14,577 English square miles. Till the last Eastern war Bessarabia occupied the whole space between the Dniester and the Pruth from the Austrian frontier to the Black Sea. The northern portion of Bessarabia is mountainous, the southern flat and low,—the limit between the two being marked by the so-called upper Trajan wall, an artificial elevation executed, according to some, in the end of the 2d century A.D., under Trajan, but, according to others, in the 3d century, under Probus. This wall extends from the confluence of the Botna with the Dniester to the Pruth. In northern or mountainous Bessarabia two systems of elevations may be distinguished. The first is an immediate offshoot of the Carpathians, and occupies the whole of Khoteen, or the north-western district of the government. It rises about 450 feet above the valley of the Dniester, and consists of strata of Palæozoic formation, sandstones, schists, and limestones. The second system is especially extended in the very middle of Bessarabia, and may be called the Yassa-Orgievian range. It consists of limestone of secondary formation, and its highest point is Mouat Megura, about 20 miles S. of Bialita, between Bakhmet and Poltava. The low portion of Bessarabia stretches south from the Trajan wall, with a length of 133

miles and a breadth of 33, and is well known as the Budjak steppe. The surface is perfectly level; and the soil, except in the region along the shore, consists of a thick bed of loam. The province is washed on its eastern parts by the Black Sea only for the distance of 20 miles to the south of the estuary of the Dniester. Its only seaport is that of Akerman, situated on the estuary of the Dniester. This river divides Bessarabia from Kherson and Podolia for a distance of almost 600 miles. The shores of the Dniester are in general high and steep, and numerous bars obstruct its channel, particularly at Yampol and Bakat. On the Bessarabian bank are situated the towns Khoteen, Cosoka, and Bender; and thirteen natural harbours for ships are counted along this side of the river. Among the principal tributaries are the Reuth, the Ikal, the Buik, and Botna. Another important stream is the Pruth, of which the left shore skirts the province for a distance of more than 140 miles. The navigation on the Pruth is not important; its course is impeded by bars and falls. The only important lakes in the government lie along the coast of the Black Sea in the Akerman district. Marshes extend along the Reuth and its tributaries, and there are also some along the Botna; they offer no great obstacles, however, to free communication. Bessarabia up to 1856 possessed great quantities of sedimental salt; but after the cessions of the Black Sea coast and the salt lakes, the quantity obtained, which formerly exceeded 60,000 tons, almost came to nothing. The climate of Bessarabia is temperate. The medium annual temperature of Keesheneff, 230 feet above the sea-level, is 50° Fahr.; the temperature of the warmest month, about 73°; of the coldest, about 20°. In the valley of the Dniester the climate is in general much healthier than in that of the Pruth; the climate of the north-west is much colder, and spring commences there ten days later.

In all the upper part there are forests, consisting principally of beech, oak, and larch, besides small quantities of birch. The chief forest region lies along the heights of the Orgieff and Yassa districts about the Megura Mountains, and extends thence east to the Dniester and south-west to Keesheneff. The Khoteen hills are almost all covered with timber. The three northern districts, Khoteen, Bialita, and Soroka, are especially suited for agriculture, and may be regarded as the granary of Bessarabia. The two intermediate districts of Orgieff and Keesheneff, though possessing a sufficiently fertile soil, are pre-eminently woodland; while the two southern, Bender and Akerman, although also fertile, have a steppe-like character, and are better adapted to the rearing of cattle.

Bessarabia, in keeping with its position near the Danube, played an important historic part in ancient times, especially in the beginning of our era, when it served as a key to the eastern approaches of the Byzantine empire. And thus, from immemorial times, nations were ceaselessly alternating with nations within its borders. The original inhabitants were the Cymri, succeeded by the Scythians. Herodotus, who had been in the Greek colonies of the Black Sea, relates that near the mouth of the Dniester (Tyrras) there lived the Tyrritians, possessing on the estuary of that river the town of Tyrras (*Oxia* or, according to Pliny, *Ophitus*). In the 2d century after Christ Bessarabia was occupied by the Geti and offshoots from the Bastroci, and in 106 A.D., the Geti were conquered by Trajan. After this subjugation of the land by the Romans, the present Bessarabia went along with Walachia, Moldavia, and Transylvania, to compose Dacia. In the 3d century appeared the Goths, recently converted to Christianity. In the 5th century Bessarabia was overrun by the Huns; after the Huns, in the end of the 5th century, arrived the Avars and the Bulgarians; and last of all came the Slavonians (Lutichi and Tervanti), who built themselves the town of Bialgorod. In the 7th century appeared the race of the Besi from whom the country acquired its present name. In the 9th century arrived the Ugrians; in the 10th the Pechenegs; in the 11th the Kumans, the Uzes, and the Polovtians; and in the 13th the Mongolians, under the leadership of Batia. In this last century, also, the Genoese founded their colonies on the shores of the Dniester. In 1367 Bessarabia formed a part of Moldavia. In 1503 the south-

ern portion of the country, or Budjak, fell under the power of the Turks; and in 1560 there settled in that district 80,000 Nogaitzians, who had devastated northern Bessarabia, then inhabited by Roumanians. These Nogaitzians acquired the name of the Bialgorod horda. Russian armies occupied Bessarabia during all the Turkish wars in the 18th century, and again in 1806-12, when it was united to Russia by the Bukharest treaty. By the Paris convention of 1856, Russia ceded the districts of Ismael and the greater part of the Cagul to Turkey, and these now form a part of Roumania. At present the government is divided into seven districts, those of Keesheneff, Akerman, Bender, Orgieff, Soroka, Khotseu, and Yassa. Bender and Akerman are subdivided into five cantons, each of the others into four. In 1860 the population numbered 968,481, and had a very varied ethnographical character. The principal portion consisted of Moldavians, descendants of the ancient Dacians. The Russmaysk or Galicians and Rayani (that is, those who have inhabited the rayas provinces of the Turkish empire), amounted to 130,000, mostly found in the districts of Khotseu, Soroka, Yassa, and Orgieff. Malo-Russians (or Little Russians) began to settle in the country in the 17th century, and now number 70,000. The Bulgarians began their immigration from the Turkish provinces in 1806-12, afterwards in 1830-34, and finally after 1856; they number 60,000. These colonies are administratively divided into three circles:—the Upper Budjak, consisting of 19, the Lower Budjak of 19, and the Isnael of 5. The Germans began to settle in Bessarabia in 1814. Their colonies, to the number of 25, are situated in the Akerman district, along the River Cogalnika. The Jews, who number 70,000, live partly in the cities Keesheneff, Khotseu, &c., but are also settled in 16 agricultural colonies. The Gypsies, or Zigan, amount to 10,000. They live a wandering life; but in the Akerman district two villages, Pharaonofu and Kasera, are permanently inhabited by them. A considerable number of Armenians and Greeks have also settled in the country during the present century.

**BESSARION, JOHANNES**, titular patriarch of Constantinople, and one of the illustrious Greek scholars who contributed to the great revival of letters in the 15th century, was born at Trebizond in 1389, or, according to others, in 1395. In 1423 he entered the order of St Basil, and studied under the celebrated Platonic scholar, George Gemistus Pletho. In 1437 he was made archbishop of Nicæa by John Palæologus, whom he accompanied to Italy in order to bring about a union between the Greek and Latin Churches. At the councils held in Ferrara and Florence Bessarion supported the Roman Church, and gained the favour of Pope Eugenius, who invested him with the rank of cardinal. From that time he resided permanently in Italy, doing much, by his patronage of learned men, by his collection of books and manuscripts, and by his own writings, to spread abroad the new learning. He held in succession the archbishopric of Siponto and the bishoprics of Sabina and Tusculum. In 1463 he received the title of patriarch of Constantinople; and it was only on account of his Greek birth that he was not elevated to the Papal chair. For five years he was legate at Bologna, and he was engaged on embassies to many foreign princes, among others to Louis XI. of France in 1471. Vexation at an insult offered him by Louis is said to have hastened his death, which took place, on the 19th November 1472, at Ravenna. Bessarion was one of the most learned scholars of his time. Besides his translations of Aristotle's *Metaphysics* and of Xenophon's *Memorabilia*, his most important work is a treatise directed against George of Trebizond, a violent Aristotelian, and entitled *In Calumniatorem Platonis*. Bessarion, though a Platonist, is not so thoroughgoing in his admiration as Pletho, and rather strives after a reconciliation of the two philosophies. His work, by opening up the relations of Platonism to the main questions of religion, contributed greatly to the extension of speculative thought in the department of theology.

**BESSÈGES**, a town of France, in the department of Gard, 20 miles north of Alais by railway, of importance for its coal and iron mines and blast-furnaces. Population in 1872, 8036.

**BESSEL, FRIEDRICH WILHELM**, a distinguished Prussian astronomer, was born at Minden on the 22d July

1784. At an early age he was placed in the counting-house of a merchant at Bremen. His strong desire to obtain a situation as supercargo on a foreign voyage led him to the study first of navigation and then of mathematics. He devoted himself with the utmost ardour to mathematical and astronomical calculations, and in 1804 undertook the reduction of the observations made on the comet of 1807. His results were communicated to Olbers, who warmly praised the young astronomer, and in 1806 recommended him for the post of assistant to Schröter in the observatory at Lilienthal. In 1810, after his reputation had been much extended by various memoirs, treating particularly of cometary orbits, he was appointed director of the new observatory then being founded by the king of Prussia at Königsberg. He was at the same time made professor of astronomy and mathematics in the university of that town. Bessel, from his keen practical intelligence, thorough acquaintance with all instrumental appliances, and complete mastery of the methods of calculation, was admirably fitted for the post of observer. The establishment at Königsberg was one of the best of its kind, and its observations, published continuously from 1813, are of great value. In 1818 Bessel completed a task on which he had been engaged for several years—the reduction of Bradley's priceless but neglected Greenwich observations. The results were published in the volume entitled *Fundamenta Astronomiæ*, the importance of which for astronomical science cannot be overrated. By its publication the author at once took his place among the first astronomers of Europe; he was received with honour by the various foreign scientific societies, and was made a privy councillor by the king of Prussia. Of his later labours in practical astronomy perhaps the most important is his determination of the parallax of the star 61 Cygni, accomplished by methods of extreme ingenuity and delicacy. The *Tabula Regionum Montana*, 1830, and *Astronomische Untersuchungen*, 2 vols., 1841-42, are continuations of the *Fundamenta*. His memoirs, contained in the *Astronomische Nachrichten*, are exceedingly numerous. A volume of *Popular Lectures* was published by Schumacher after the death of the author in 1846.

**BETEL NUT.** The name betel is applied to two different plants, which in the East are very closely associated in the purposes to which they are applied. The betel nut is the fruit of the Areca or betel palm, *Areca Catechu*, and the betel leaf is the produce of the betel vine or pan, *Chavica Betel*, a plant allied to that which yields black pepper. The areca palm is a graceful tree, which appears to be indigenous over a wide area in the East, including Southern India, Ceylon, Siam, the Malay Archipelago, and the Philippine Islands, in the whole of which it is extensively cultivated. The fruit of the palm is about the size of a small hen's egg, and within its fibrous rind is the seed or so-called nut, the albumen of which is very hard and has a prettily mottled grey and brown appearance. The chief purpose for which betel nuts are cultivated and collected is for use as a masticatory,—their use in this form being so wide-spread among Oriental nations that it is estimated that one-tenth of the whole human family indulge in betel chewing. For this use the fruits are annually gathered between the months of August and November, before they are quite ripe, and deprived of their husks. They are prepared by boiling in water, cutting up into slices, and drying in the sun, by which treatment the slices assume a dark brown or black colour. When chewed a small piece is wrapped up in a leaf of the betel vine or pan, with a pellet of shell lime or chunan; and in some cases a little cardamom, turmeric, or other aromatic is added. The mastication causes a copious flow of saliva of a brick-red colour, and gives the mouth, lips, and gums of the chewer a repulsive appearance. The habit blackens the teeth, but it is asserted by those addicted to



It that it strengthens the gums, sweetens the breath, and stimulates the digestive organs. Among the Orientals betel is offered on ceremonial visits in the same manner as wine is produced on similar occasions by Europeans. Betel nuts are further used as a source of catechu, which is procured by boiling the nuts in water. The water of the first boiling becomes red and thick, and when this is inspissated after the removal of the nuts it forms a catechu of high astringency and dark colour called in Bombay "Kossa." The nuts are again boiled, and the inspissated juice of the second decoction yields a weaker catechu of a brown or reddish colour. Betel nuts are used to some extent in the United Kingdom as the source of a charcoal tooth-powder, which, however, has no special virtue, and they are also employed by turners for ornamental purposes, and for coat buttons on account of the beauty of their structure. Recently they have come into repute as a vermifuge, and have been admitted into the *Supplement to the British Pharmacopœia* (1874) as a cure for tape-worm. The quantity of betel nuts consumed in the East is enormous. Ceylon alone exports about 70,000 cwt. annually; Travancore has upwards of a million of trees, the average produce of each being 300 nuts annually, or about 6000 tons in all; Sumatra is little less productive, and the small island of Penang, named from the Malayan name for the tree, is estimated to contain half a million trees. The nuts of other species of *Areca* are used by the poorer classes in the East as substitutes for the genuine betel nut.

**BETHANY** (i.e., probably, the "House of Dates"), a village, now called *El' Azariyeh*, or *Lazarieh*, nearly two miles E.S.E. from Jerusalem, on the eastern slope of the Mount of Olives, at a height of 2208 feet above the sea. The whole importance of the place is derived from its connection with New Testament history, it being never mentioned in the Old Testament or Apocrypha. It was the residence of Lazarus and his sisters, a favourite retreat of the Saviour, and the scene not only of his greatest miracle but also of his ascension. From the 4th century down to the time of the Mahometan invasion several ecclesiastical buildings were erected on the spot, but of these no distinct traces remain. *Lazarieh* is a poor village of about twenty families, with few marks of antiquity; and there is no reason to believe that the houses of Mary and Martha and of Simon the Leper, or the sepulchre of Lazarus, still shown by the monks, have any claims to the names they bear.

**BETHEL** (i.e., in Hebrew, the "House of God"), originally called *Luz*, an ancient city of Palestine, on the borders of the tribe of Benjamin, eleven English miles north of Jerusalem. Of the origin of its new name two accounts are given in Genesis, both of them, however, connecting it with the history of Jacob. After the conquest of Canaan by the Israelites Bethel became a resting-place of the ark, and at a later date it was chosen as a royal residence and a seat of idolatrous worship by several of the renegade kings. It seems to have continued to flourish down into the Christian era, some remains still existing of its ecclesiastical buildings. Its ruins, which now bear the name of *Beitin*, occupy about three or four acres.

**BETHESDA** was a pool or public bath in Jerusalem, where miraculous cures were believed to be performed; now usually identified with the *Birket Israel*, near St Stephen's Gate. See **JERUSALEM**.

**BETHLEHEM** (i.e., in Hebrew, the "House of Bread"), a small town in Palestine, situated on a limestone ridge, about six miles from Jerusalem, on the main road to Hebron. It was a place of great antiquity; and, under the name of *Ephrata* is mentioned in the history of Jacob. From the book of Ruth, which contains the romantic story of some of its inhabitants, it would appear to have had special con-

nection with the land of Moab. At a later date it became famous as the birthplace of David, but does not seem to have received any special favours at his hand. It was fortified by *Behoboam*; and the neighbouring inn of *Chimham* seems to have become a regular rendezvous for travellers proceeding to Egypt. Almost complete obscurity, however, was gathering round it when it became one of the world's most memorable spots—the birthplace of the Saviour. Desecrated during the reign of *Hadrian* by a grove of *Adonia*, the traditional scene of the nativity (a grotto on the eastern part of the ridge) was enclosed by the *Empress Helena* with a noble basilica, which still stands, surrounded by the three convents successively erected here by the Greek, Latin, and Armenian Churches. In the neighbourhood is still shown the traditional grotto where *Jerome* spent a portion of his life busy with his Latin translation of the Scriptures. Captured by the Crusaders in the 11th century, *Bethlehem* was made an episcopal see; but the bishopric soon sank into a titular dignity. The present village is well built and clean, and the inhabitants, who number about 3000, profess Christianity. The carving of crucifixes and other sacred mementoes gives employment to a number of persons.

**BETHUNE**, the chief town of an *arrondissement* in the French department of *Pas de Calais*, situated on a rock above the *River Brette*, 16 miles N.N.W. of *Arras*. It is strongly fortified, and its defences are partly the work of *Vauban*. It has a tribunal of primary jurisdiction, a communal college, a Gothic church, two hospitals, and manufactures of linen, cloth, and bear. The trade, chiefly in grain, cheese, linen, and oil, is facilitated by the canal, which unites the *Lawe* with the *Lys*. The town, which dates from the 11th century, was taken by the allied forces in 1710, and restored to France by the treaty of *Utrecht*. Population in 1872, 4594.

**BETLIS**, **BITLIS**, or **BEDLIS**, a town of Turkish Armenia, in the *Sandjak of Mûsh*, situated near the south-west corner of *Lake Van*, in a highly cultivated valley, which is watered by the *Bitlis-chai*, a sub-tributary of the *Tigris*. Partly owing to the irregularity of the ground, the houses are scattered without much attention to order, and most of them are surrounded with gardens or orchards. The castle of the *Bey*, a straggling structure, is situated on the lava rock that bounds the valley; while in the centre of the town, on an eminence so steep that it is only accessible by a road winding round it, stand the ruins of an ancient fortress of great strength. *Bitlis* is a great seat of the dancing *dervishes*, who have twelve convents in the place. The Armenians, who form about a fourth of the population, have four churches and as many monasteries, and the Mahometans possess numerous mosques and medresses. A considerable trade is carried on, as well as the manufacture of gold and silver wares, the weaving of cotton-cloth and carpets, and the preparation of tobacco. According to an Armenian tradition *Bitlis* was founded by *Alexander the Great*. In 1514 it became a Turkish possession, and it has for about three centuries been held as a fief by a Kurdish family. The population is variously estimated at from 10,000 to 12,000.

**BETTERTON, THOMAS**, the best English actor of his time, was the son of *Mr Betterton*, under-cook to *King Charles I.*, and was born at Westminster in 1635. He was apprenticed to *Mr Rhodes*, a bookseller near *Charing Cross*. *Rhodes*, who had been wardrobe-keeper to the theatre in *Blackfriars*, obtained in 1659 a licence to set up a company of players at the *Cockpit* in *Drury Lane*; and there *Betterton* made his first appearance on the stage. On the opening of the new theatre in *Lincoln's-Inn-Fields* in 1662, *Sir William Davenant*, the patentee, engaged *Betterton* and all *Rhodes's* company to play in his *Sicge of*

*Rhodes.* Betterton became a great favourite with the king, and was sent to Paris to examine the French stage, with a view to the introduction of improvements. According to Cibber it was after his return that shifting scenes were first used in the English theatre instead of tapestry. In 1670 Betterton married Mrs Sanderson, a good actress of the same company; and the marriage was a very happy one. In 1693, when he had just lost the little money he had laid by, he was enabled by the aid of his friends to erect a new playhouse in the Tennis Court in Lincoln's-Inn-Fields. It was opened in 1695 with Congreve's *Love for Love*. But in a few years the profits greatly fell off; and Betterton, infirm through age, and labouring under violent attacks of the gout, determined to quit the stage. On his retirement the public gave him a benefit-night, when, though upwards of seventy, he played the part of Valentine in the comedy of *Love for Love*: the profits are said to have amounted to upwards of £500. His performance of Hamlet after this time is particularly mentioned in the *Tattler*. In the spring of 1710 he made his last appearance on the stage in his celebrated part of Melantius in *The Maid's Tragedy*. A rash attempt to reduce the swelling of his limbs by external applications threw the gout into his head, and he died on the 28th of April. His body was interred with much ceremony in the cloisters of Westminster. Betterton was author of several dramatic works which were popular in their day. An estimate of his character and abilities is given in the *Apology for my Own Life*, &c., of his friend and rival Colley Cibber.

**BETTINELLI, SAVERIO**, Italian Jesuit and littérateur, was born at Mantua on the 18th of July 1718. After studying under the Jesuits in his native city and at Bologna, he entered the society in 1736. He taught the belles-lettres, from 1739 to 1744, at Brescia, where the Cardinal Quirini, Count Massucelli, Count Duranti, and other scholars, formed an illustrious academy. He next went to Bologna to pursue the study of divinity, and there he enjoyed the society of many learned and literary men. At the age of thirty he went to Venice, where he became professor of rhetoric, and was on friendly terms with the most illustrious persons of that city and state. The superintendence of the college of nobles at Parma was entrusted to him in 1751; and he had principal charge of the studies of poetry and history, and the entertainments of the theatre. He remained there eight years, visiting, at intervals, other cities of Italy, either on the affairs of his order, for pleasure, or for health. In 1755 he traversed part of Germany, proceeded as far as Strasburg and Nancy, and returned by way of Germany into Italy, taking with him two young sons or nephews of the prince of Hohenlohe, who had requested him to take charge of their education. He made, the year following, another journey into France, along with the eldest of his pupils; and during this excursion he wrote his famous *Lettere dieci di Virgilio agli Arcadi*, which were published at Venice with his *sciolti* verses, and those of Frugoni and Algarotti. The opinions maintained in these letters against the two great Italian poets and particularly against Dante, created him many enemies, and embroiled him with Algarotti. In 1758 he went into Lorraine, to the court of King Stanislaus, who sent him on a matter of business to visit Voltaire. Voltaire presented him with a copy of his works, with a flattering inscription in allusion to Bettinelli's *Letters of Virgil*. From Geneva he returned to Parma, where he arrived in 1759. He afterwards lived for some years at Verona and Modena, and he had just been appointed professor of rhetoric there, when, in 1773, the order of Jesuits was abolished in Italy. Bettinelli then returned into his own country, and resumed his literary labours with new ardour. The siege of Mantua by the French compelled him to leave the city, and he

retired to Verona, where he formed an intimate friendship with the Chevalier Hippolito Pindemonti. In 1797 he returned to Mantua. Though nearly eighty years old he resumed his labours and his customary manner of life. He undertook in 1799 a complete edition of his works, which was published at Venice in 24 vols. 12mo. Arrived at the age of ninety years, he still retained his gaiety and vivacity of mind, and died on the 13th September 1808. The works of Bettinelli are now of little value. The only one still deserving remembrance, perhaps, is the *Risorgimento negli studi, nelle Arti e nel Costumi dopo il Mille*, a sketch of the progress of literature, science, the fine arts, industry, &c., in Italy.

**BETTING** may be defined as the staking or pledging between two parties of some object of material value on the issue or contingent issue of some event or contest. The pursuit (it can hardly be termed a pastime, science, or art) of betting has been in vogue from the earliest days of civilisation, commencing in the East with royal and noble gamblers, and gradually extending itself westwards and throughout all classes. In all countries where the English tongue is spoken betting is now largely indulged in; and in the United Kingdom it has spread to such an extent amongst all grades of society during the last twenty years that the interference of the Legislature has been found necessary. The evils it has been productive of are too well known to call for comment here, and the principles require to be treated solely from mathematical and legislative points of view.

The first principle of all betting is that "you cannot win where you cannot lose." Accordingly no bets are "play or pay" except those on certain events enumerated below, or unless such a stipulation is laid down at the time the bet is made. Betting may be divided into "bookmaking" and "backing." The former consists in laying the odds, and, theoretically speaking, secures a small though certain profit, were all debts paid and the number of starters for the event large. During the first half of the 19th century bookmaking was a far more lucrative business than now, because betting was confined to the wealthier classes and bad debts were fewer. Also, betting commenced many months before a great race, and so the bookmaker had more opportunities of laying against all the entries, whereas most betting on play or pay events is now done just before the start. Taking the St Leger (always a play or pay event) of 1875, the following table represents a £100 book opened a week before the race, according to the Continental betting quotations, September 7, 1875. Those marked † did not eventually start.

6 to 1	against Gilbert	.....	£100	to	£16 18 4
7 " 1	"	St Cyr	.....	"	to 14 5 8
7 " 1	"	Earl of Dartrey	...	"	to 14 5 8
10 " 1	"	Dreadnought	.....	"	to 10 0 0
10 " 1	"	Balfie	.....	"	to 10 0 0
12 " 1	"	†Bay of Naples	.....	"	to 8 6 8
16 " 1	"	Babages II.	.....	"	to 6 5 0
16 " 1	"	Seymour	.....	"	to 6 5 0
20 " 1	"	New Holland	.....	"	to 5 0 0
25 " 1	"	Brechloader	.....	"	to 4 0 0
25 " 1	"	Perkin Warbeck	..	"	to 4 0 0
25 " 1	"	Craigmillar	.....	"	Winner.
25 " 1	"	†Claremont	.....	"	to 4 0 0
25 " 1	"	†Repentance Colt	...	"	to 3 0 7
25 " 1	"	†Salvator	.....	"	to 3 0 7
40 " 1	"	Saint Leger	.....	"	to 2 10 0
40 " 1	"	†Temple Bar	.....	"	to 2 10 0
50 " 1	"	†Telescope	.....	"	to 2 0 0
50 " 1	"	†Garterly Bell	.....	"	to 2 0 0
50 " 1	"	†Sister to Musket	..	"	to 2 0 0

£120 2 6

In this instance twenty horses are quoted in the betting. Assuming that the bookmaker finds a customer to back each of them, and that he encounters no bad debts, he receives £120, 2s. 6d., and has to pay £100 to the person with whom he laid £100 on St

against Craigmillar, the winner. This leaves a gain of £20, 2s. 6d. or 20½ per cent., but even then travelling and other expenses have not been taken into consideration, and the fewer losses that are backed the less accordingly will be the bookmaker's profit. In fact, the non-backing of any one horse in this instance materially reduces the profit. The race in question was particularly favourable for bookmakers, both because so many horses were scratched (representing a gain of £26, 17s. 10d.), and because at the date supposed the winner was at such long odds. At the actual start the odds against the beaten horses were 9 to 2, and 6, 7, 9, 10, 12, 20, 25, 50, and 66 to 1 respectively, and against the winner 20 to 3. This will be found to leave the bookmaker, had he commenced his book the day of the race, a profit of £1, 12s. 6d. only, and had the first favourite won there would have been a loss of £5, 11s. 11d. There were 178 entries for this St Leger, and if the book had been opened many months before the race, and the bookmaker had been able to obtain customers, the favourites would have been backed at longer odds, bringing less profit from this source, but then more eventual non-starters are backed, which is certain profit. The chief principles of bookmaking are the same, whether the number of starters for an event be unlimited, or two only, though, in the latter case, there is no certain profit, as there are not sufficient starters to enable the bookmaker to save his stake. His only chance then is that he has been circumspect enough to have laid his odds on the winner.

"Backing" is a very plain matter, but in the long-run invariably a losing method of betting. It simply consists in taking the odds laid by a bookmaker against one or more starters for any event. If it be a play or pay event, and the possible starter be scratched, the backer loses his money at once. Although a backer may become possessed of such special information as may enable him to win large sums occasionally, his losses will in the long-run exceed them. In fact, the bookmaker virtually keeps a bank against him.

"Hedging" consists in laying off at shorter odds part of the sums various starters may have been backed for. Thus, a backer has taken £50 to £1 about A, B, and C respectively for a play or pay event some time before the date fixed for the contest. A turns out a non-starter, so there is a certain loss of £1. At starting the odds have come down to say 2 to 1 against B, and 3 to 1 against C. So the backer lays £50 to £25 against B, and £50 to £16, 13s. 4d. against C. If neither wins he receives £41, 13s. 4d., out of which he has to pay £3 to the bookmaker, leaving a profit of £38, 13s. 4d. Should B win he receives £50 from the bookmaker, and £16, 13s. 4d. on account of C's defeat, out of which he has to pay £2 to the bookmaker on account of A and C, and the £50 he has laid against B, so the profit left is £14, 13s. 4d. Should C win, the hedger receives £50 from the bookmaker, and £25 on account of B's defeat, out of which he has still to pay the bookmaker £2 on account of A and B, and the £50 he has laid against C, so the profit left is £23.

The only events that are now play or pay are the Derby, Oaks, St Leger, Two Thousand Guineas, One Thousand Guineas, Cesarewitch, and Cambridgeshire Stakes, the Ascot, Goodwood, and Doncaster Cups, and all handicaps above £300 value, with two forfeits, the minor whereof is not less than £5. In all other betting the backer is entitled to a start for his money, unless the contrary is stipulated at the time the bet is made.

In the United Kingdom betting has been the source of considerable legislation during the past thirty years. Curiously enough, by the 9th of Queen Anne, if any one gained over £10 by betting, the loser was entitled to pursue for repayment of the stake if he had paid it, and if he did not do so within three months any one might sue for treble the amount with costs. After it had become a dead letter some informers raked up this Act in 1844, and the result was the insertion of a clause in the Gaming Act, 8 and 9 Vict. c. 109, annulling the old statute. During the next seven years betting on horse races increased to an enormous extent. "List shops," where the proprietors

kept a bank against all comers, and backers could stake their money in advance on a horse, sprung up in the metropolis and large towns, leading to many acts of flagrant dishonesty. Sir Alexander Cockburn, then attorney-general, accordingly introduced the Betting Houses Act, 16 and 17 Vict. c. 119, whereby all houses or places kept for such purposes were brought under the above-mentioned Gaming Act, and might be proceeded against as a common nuisance and contrary to law,—heavy penalties being incurred by the owners, occupiers, or advertizers of such houses or places. Betting on race-courses, or at Tattersall's and similar private clubs, where money is not received in advance, was not meant to be interfered with. For some time this legislation had the desired effect till attempts were made to evade it by receiving money through the post. These were successful till the summer of 1869, when the Government suddenly bestirred itself, and several prosecutions took place. As the Act, however, did not extend to Scotland, the betting-house keepers removed there or went abroad, and their advertisements at such addresses were still legal. This led to 37 Vict. c. 14, extending 16 and 17 Vict. c. 119 to Scotland, and making all advertisements of betting-houses, whether in or out of the United Kingdom, illegal. It came into force on 31st July 1874, and almost exterminated the receiving of money in advance, especially as it is now enforced very strictly.

In 1866 a system of betting, termed *Paris mutuels*, was started in France. It consisted of agencies where any one may back a probable starter for any sum or sums he pleases. The whole of the money thus staked on all starters is added together, a commission deducted by the agent for his trouble, and the balance divided in "equal shares," or *Paris mutuels*, amongst those who have backed the victor. In this instance the agent's gain is, of course, certain. It has been found, however, that unlicensed opportunities of staking money in advance have produced the same evils in France as in England. During the past three years the French Government have taken the matter up strongly, and betting-houses and agencies are now as effectually doomed on the French as on the English side of the Channel.

In the United States betting is also illegal. Under the Gambling Act, whenever any money has been staked for a bet, either side can sue the stakeholder and recover his portion of the money, either before or after the bet has been decided. Owing, however, to the strong public sentiment which naturally condemns such a course, proceedings against stakeholders are excessively rare. Any voter betting on the result of an election forfeits his franchise, yet the heaviest betting in the States is on elections, and the betters go unchallenged to the poll. (H. F. W.)

BETUL, a hilly district of British India, in the Central Provinces, comprising the westernmost section of the great Sâtpurâ plateau, situated between 21° 20' and 22° 35' N. lat., and 77° 20' and 78° 35' E. long. It is bounded on the N. by the Hoahangâbâd district and the Makrâi territory, on the E. by the district of Chhindwârâ, on the S. by the commissionership of West Berârâ, and on the W. by the district of Hoahangâbâd. The area is about 4118 square miles; the population, as ascertained by the census of 1866, 258,335. In 1872 the population had increased to 284,055, of whom 163,788 were Hindus, 4555 Mahometans, 937 Buddhists and Jains, 19 Christians, and 109,756 aborigines; population, 69 per square mile. The mean elevation of the district above the sea is about 2000 feet. The country is essentially a highland tract, divided naturally into three distinct portions, differing in their superficial aspects, the character of their soil, and their geological formation. The northern part of the district forms an irregular plain of the sandstone formation. It is a well-wooded tract, in many places stretching out in charming glades like an English

park, but it has a very sparse population and little cultivated land. In the extreme north a line of hill rises abruptly out of the great plain of the Narbadá valley. The central tract alone possesses a rich soil, well watered by the Machná and Sámpana rivers, almost entirely cultivated and studded with villages. To the south lies a rolling plateau of basaltic formation (with the sacred town of Multái, and the springs of the River Tapti at its highest point), extending over the whole of the southern face of the district, and finally merging into the wild and broken line of the Gháts, which lead down to the plains. This tract consists of a succession of stony ridges of trap rock, enclosing valleys or basins of fertile soil, to which cultivation is for the most part confined, except where the shallow soil on the tops of the hills has been turned to account.

The principal rivers of the district are the Tapti, Wardhá, Bel Machná, Sámpaná, Morar, and Tawá. The Tapti rises a few miles from Multái, traverses the southern part of the district, and then plunges into the gorge of the Sátpurá hills, formed on the one side by the Chikaladá hills of Berar, and on the other side by the wild Káibhát hills of Hoahangábad. The Wardhá can hardly be called a river of the district, as it merely takes its rise in the Sátpurá hills on the south-eastern boundary. The River Bel also rises in the high plateau of Betul, and forms one of the chief affluents of the Kanbán. The Machná and Sámpana rise upon the hills that shut in the rich basin of the district. They unite their waters at the town of Betúl, force their way through the Sátpurá range, and join the Tawá near Sháhpur. The Morar rises in the Sátpurá hills within the district, and enters Hoahangábad near the town of Seoni. The Tawá rises in Ohhindwár, and flowing for a short distance through the north-east corner of this district, eventually joins the Narbadá above Hoahangábad. These are the rivers of importance; but throughout the district, and more especially amid the trap formation, there are a number of smaller streams useful for irrigation. The principal agricultural products of the district are wheat and pulses, more than three-fourths of the open lands being devoted to these crops. The other products are cotton, rice, millet, rye, sugar-cane, and opium. The area under sugar-cane cultivation is estimated at 2400 acres, the juice extracted from it being exported in its raw state. The principal agricultural tribe is the Kumbá, many of whom are modern immigrants from Northern India. The aboriginal Gonds are found in all the wild jungle villages, where they follow the nomadic system of cultivation known as the *dahya*. Extensive forests occupy some 700 square miles of the district area, and yield teak and other good timber. Coal occurs in many parts of the district, but is not worked, as except at one place not a single seam has been found exceeding 3 feet in thickness, and it is doubtful if a seam of that thickness can be profitably mined in India. District revenues in 1868-69—land revenue, £19,150; excise, £7219; assessed taxes, £1186; forests, £1218; stamps, £2743; total, £31,475. Strength of regular constabulary and town police, 333 men; cost, £3857 per annum.

Little is known of the early history of the district except that it must have been the centre of the first of the four ancient Gond kingdoms of Kherlá, Deogarh, Mandla, and Chánda. According to Fariáhtá, these kingdoms engrossed in 1398 all the hills of Gondwáná and adjacent countries, and were of great wealth and power. About the year 1418 Sultán Husain Sháh of Málwa invaded Kherlá, and reduced it to a dependency. Nine years later the Rájá rebelled, but although with the help of the Báhmíni kings of the Deccan he managed for a time to assert his independence, he was finally subdued and deprived of his territories. In 1467 Kherlá was seized by the Báhmíni king, but was afterwards restored to Málwa. A century later the kingdom of Málwa became incorporated into the dominions of the emperor of Delhi. In 1703 a Musáلمان convert of the Gond tribe held the country, and in 1743 Raghuji Bhonáá, the Marhattá ruler of Berar, annexed it to his dominions. The Marhattás in the year 1818 ceded this district to the East India Company as payment for a contingent, and by the treaty of 1836 it was formally incorporated with the British possessions. Detachments of British troops were stationed at Multái, Betul, and Sháhpur to cut off the retreat of Apá Sáhíb, the Marhattá general, and a military force was quartered at Betul until June 1862.

The ruined city of Kherlá formed the seat of government under the Gonds and preceding rulers, and hence the district was, until the time of its annexation to the British dominions, known as the "Kherlá Sarkár." The town of Multái contains an artificial tank, from the centre of which the Tapti is said to take its rise; hence the reputed sanctity of the spot, and the accumulation of temples in its honour.

The climate of Betul is fairly salubrious. Its height above the plains and the neighbourhood of extensive forests moderate the heat, and render the temperature pleasant throughout the greater part of the year. During the cold season the thermometer at night falls below the freezing point; little or no hot wind is felt before the end of April, and even then it ceases after sunset. The nights in the hot season are comparatively cool and pleasant. During the monsoon the climate is very damp, and at times even cold and raw, thick clouds and mist enveloping the sky for many days together. The average annual rainfall is 40 inches. In the denser jungles malaria prevails for months after the cessation of the rains, but the Gonds do not appear to suffer much from its effects. Travellers and strangers who venture into these jungles run the risk of fever of a severe type at almost all seasons of the year.

BETWÁ, a river of India, which rises in the native state of Bhopál in Málwa, and after a course of 360 miles for the most part in a north-easterly direction, falls into the Jamná at Hamirpur in 26° 57' N. lat. and 80° 17' E. long.

BEUDANT, FRANÇOIS SULPICE, a French mineralogist and geologist, was born at Paris in 1787, and died in 1862. He was educated at the Polytechnic and Normal schools, and in 1811 was appointed professor of mathematics at the Lycée of Avignon. Thence he was called, in 1813, to the Lycée of Marseilles to fill the post of professor of physics. In the following year the royal mineralogical cabinet was committed to his charge to be conveyed into England, and from that time his attention seems to have been directed principally towards geology and cognate sciences. In the year 1818 he undertook, at the expense of Government, a geological journey through Hungary, and the results of his researches, *Voyage Minéralogique et Géologique en Hongrie*, 3 vols. 4to, with atlas, published in 1822, established for him a European reputation. He was about the same time appointed to the professorship of mineralogy in the Paris Faculty of Sciences. His treatises on physics (*Traité de Physique*, 6th ed., 1838) and on mineralogy and geology (*Cours Élémentaire de Minéralogie et Géologie*, 1841) were very popular. Beudant also, when holding the post of inspector of the university, published a valuable French grammar.

BEULÉ, CHARLES ERNEST, a French archaeologist and man of letters, was born at Saumur 29th June 1826, and died 4th April 1874. He was educated at the École Normale, and in 1852 was sent to Athens as one of the professors in the École Française established there. At first distinguished as a man of fashion, he afterwards devoted himself with intense vigour to archaeological researches. He had the good fortune to discover the propylæe of the Acropolis, and his work, *L'Acropole d'Athènes* (2 vols. 1854), was published by order of the minister of public instruction. Promotion and distinctions followed rapidly upon his first successes. He was made doctor of letters, chevalier of the Legion of Honour, professor of archaeology at the Bibliothèque Impériale, member of the Academy of Inscriptions, and perpetual secretary of the Academy of Fine Arts. Like too many French men of letters, he joined eagerly in political affairs, with which the last few years of his life were entirely occupied. The most important of his writings are *Études sur le Péloponnèse*, 1855; *Les Monnaies d'Athènes*, 1858; *Histoire de la Sculpture avant Phidias*, 1864; *Histoire de l'Art Grec*, 1870.

**BEUTHEN**, the chief town of a circle in the government of Oppeln in Prussian Silesia, on the railway between Oppeln and Cracow, about 50 miles from the former. It is the centre of the mining district of Upper Silesia, and its population, which numbered 15,711 in 1871, is mainly engaged in mining operations. Cloth and linen weaving, however, is also carried on. Beuthen is an old town, and was formerly the capital of the lordship of Beuthen, which belonged to the counts of Donnersmark. It is frequently called Ober Beuthen to distinguish it from the following.

**BEUTHEN**, or **NIEDER BEUTHEM**, a town in the government of Liegnitz, in Silesia, on the Oder, and the capital of the mediæval principality of Carolath-Beuthen. The chief industries of the place are straw-plaiting, boat-building, and the manufacture of pottery; and a considerable traffic is carried on by means of the river. Population in 1871, 3826

**BEVERLEY**, a market and borough town in the East Riding of Yorkshire, about a mile from the River Hull, with which it communicates by means of a canal called the Beverley Beck. It consists principally of one long wide street, upwards of a mile in length, and terminated by an ancient gateway. The magnificent collegiate church of St John is in size and splendour superior to many cathedrals. Having been erected at different times it exhibits various styles of Gothic architecture. The west front is said by Rickman to be the finest of its kind in England. It is 334 feet in length from east to west; the breadth of the nave and side aisles is 64 feet; the transept is 167 feet long; and the two towers at the west end are 200 feet in height. One of its most remarkable monuments is the Percy shrine. St Mary's church is also an exceedingly handsome and spacious Gothic building. The market-place, which comprises an area of nearly 4 acres, is ornamented with an octangular market-cross. The grammar school is of great antiquity, and has two fellowships, six scholarships, and three exhibitions at St John's College, Cambridge. There are several national and two infant schools, a blue-coat school, a mechanics' institute, a news-room, several banks, a theatre, a jail, and a cattle-market. There is a large trade in grain, timber, and coal. The tanning of leather is the principal industry; but there are also several important manufactories of agricultural implements and of artificial manures, as well as whiting-factories, corn and linseed mills, and breweries and malt-kilns. It formerly returned two members to parliament, but was disfranchised in 1870. Population of municipal borough in 1871, 10,218.

**BEVERLEY**, a seaport of Massachusetts in the United States, situated on a branch of Ann Harbour, and connected with Salem by a bridge built in 1785. It is 16 miles N.E. of Boston, on the Eastern Railway, and is connected with Gloucester by a branch line. The principal industry is the manufacture of shoes; and a considerable number of people are employed in the coasting trade and fisheries. Population in 1870, 6507.

**BEVERLEY**, **JOHN** or, a celebrated prelate, who flourished during the 7th and 8th centuries, was born at Harpham in Northumbria. He received his education at Canterbury, and after his return to the north was the instructor of the Venerable Bede. In 685 he was made bishop of Hagolstad or Hexham, and two years later was promoted to the archbishopric of York. He resigned his see in 717, and retired to a college which he had founded some years before at Beverley, where he died in 721. He was celebrated for his scholarship as well as for his virtues. The following works are ascribed to him:—*Pro Luca Exponendo* (an exposition of Luke); *Homilia in Evangelia*; *Epistola ad Heribaldum, Audenam, et Bertinum*; *Epistola ad Holdam abbatissam*.

**BEWDLEY**, a market and borough town in the parish of Ribblesford, in the county of Worcester, 129 miles from London, on the Severn Valley Railway. It is well built, and stands on an eminence near the River Severn, over which there is an elegant bridge, erected in 1797. It has a town-hall, a free grammar school, and several charities; and manufactures combs, brass and iron wares, leather, and malt. It returns one member to parliament. Population of parliamentary borough in 1871, 7614.

Bewdley, or, as it was formerly called, *Beaulieu*, was a place of some importance in the 13th century, and had the right of sanctuary for those who shed blood. Henry VII. built a palace in the town for his son Arthur, who was married there by proxy to Catherine of Aragon; but no remains of the building, which was greatly injured during the wars of the 17th century, can now be traced. The town, which was incorporated by Edward IV., formerly belonged to the Marches of Wales, but was assigned to Worcestershire by Henry VIII.

**BEWICK**, **THOMAS**, who may be considered as the reviver of wood-engraving in England, was born at Cherryburn, near Newcastle-on-Tyne, in August 1753. His father rented a small colliery at Mickleybank, and sent his son to school at Mickley. He proved a poor scholar, but showed, at a very early age, a remarkable talent for drawing. He had no tuition in the art, and no models save natural objects. At the age of fourteen he was apprenticed to Mr Beilby, an engraver in Newcastle. In his office Bewick engraved on wood for Dr Hutton a series of diagrams illustrating a treatise on mensuration. He seems thereafter to have devoted himself entirely to engraving on wood, and in 1775 he received a premium from the Society for the Encouragement of Arts and Manufactures for a woodcut of the "Huntaman and the Old Hound." In 1784 appeared his *Select Fables*, the engravings in which, though far surpassed by his later productions, were incomparably superior to anything that had yet been done in that line. The *Quadrupeds* appeared in 1790, and his great achievement, that with which his name is inseparably associated, the *British Birds*, was published from 1797–1804. Bewick, from his intimate knowledge of the habits of animals acquired during his constant excursions into the country, was thoroughly qualified to do justice to his great task. Of his other productions the engravings for Goldsmith's *Traveller* and *Deserted Village*, for Parnall's *Hermite*, for Somerville's *Chase*, and for the collection of *Fables of Esop and others*, may be specially mentioned. Bewick was for many years in partnership with his former master, and in later life had numerous pupils, several of whom gained distinction as engravers. He died on the 8th November 1823. His autobiography (*Memoirs of Thomas Bewick, by Himself*, 8vo, London) appeared in 1862.

**BEYLE**, **MARIE-HENRI**, better known as De Stendhal, the most celebrated of his many *noms de plume*, was born at Grenoble on the 23d January 1783. His father was an *avocat* at the parliament of Grenoble, and his family, though not noble, was of good descent. His early education was conducted mainly by priests, who seem to have misunderstood his very peculiar character, and for whom he ever afterwards entertained a profound aversion and contempt. At the age of twelve he was sent to the *École Centrale*, newly established at Grenoble, and continued in attendance for four years, during which time he distinguished himself in all his studies. In 1799 he was preparing to become a candidate for the *École Polytechnique* when his plans were disturbed by an offer from M. Daru, a distant relative, of some appointment connected with the ministry for war. In the following year he accompanied M. Daru to Milan, on the chance of some suitable post offering itself. He was present at the battle of Marengo; and carried away, apparently, by the military enthusiasm consequent on

Napoleon's brilliant victories, he suddenly enlisted as quartermaster in a dragoon regiment. In a month's time he was made sub-lieutenant, and for about a year and a half acted as aide-de-camp to General Michaud. But the routine of garrison life, to which he was soon afterwards condemned, made him heartily tired of a military career. On the conclusion of the peace of Amiens (1802) he threw up his commission, and went to reside with his family at Grenoble. From them he obtained means to take up his abode in Paris, where for some time he continued to devote himself to study and literary work. In 1805 he suddenly accepted a situation as clerk in a mercantile house at Marseilles, and remained there nearly a year,—in fact, till the actress, for whose sake he had taken this curious step, married a wealthy Russian. In the following year he again accompanied M. Daru into Germany, and was appointed to superintend the possessions of the emperor in Brunswick. Whatever German he learnt there was afterwards completely forgotten. In his official capacity as connected with the commissariat he took part in the ill-fated Russian campaign of 1812, and remained loyal to the fallen emperor. He declined to lay himself out for employment under the new régime, and retired to Milan, where he resided till 1821. His early works, chiefly on painting and music, date from this period of his life. The *Lettres écrites de Vienne sur Haydn, sur une Visite de Mozart, &c.*, which appeared in 1814 under the pseudonym of Alexandre César Bombet, were mainly plagiarized from Carpani. With some slight alterations the work was reproduced in 1817 as *Vies de Haydn, Mozart, et Metastase*. In the same year he published, under various assumed names, *Histoire de la Peinture en Italie*, which contains some good but unsystematic criticism, and *Rome, Naples, et Florence en 1817*. In 1821 he was compelled to return to France, an unfounded suspicion that he was a French spy having somehow arisen at Milan. During the following nine years he resided at Paris, and gradually began to acquire his high reputation as an accomplished litterateur and man of the world. He was an admirable talker and full of anecdote, which in his opinion ought to form the staple of conversation. His fine analytic powers were displayed to full advantage in the curious work, *De l'Amour*, which he published in 1822, but the book did not find an appreciative audience. The *Vie de Rossini*, which followed, was more successful; and the pamphlet *Racine et Shakespeare* did good service for the cause of Romanticism in its struggle with the rigid classical canons of older French literature. In 1829 appeared his *Promenades dans Rome*, full of information, criticism, and original observation, but somewhat chaotic in form. He was appointed consul at Trieste in 1830, and three years later he quitted that place with the greatest joy for a similar post at Civita Vecchia. There he remained till 1841, with frequent absences, one extending from 1836 to 1839, during which he paid a short visit to London. In 1841 his health gave way, and he returned to Paris, where he died on the 22d March 1842.

Beyle, during his lifetime, was known to but a very small circle of readers; within the last twenty years, however, his popularity has greatly increased, and his many fine powers have received due recognition. It is not probable that he will ever have a very extended influence; his writings are "caviare to the general," and can only be appreciated by those qualified to take pleasure in the cynical reflections of mere egotism. For Beyle's philosophical creed, so far as he can be said to have had one, was materialism, and his ideal of humanity aesthetically refined selfishness. His strength lay in keen criticism and in acute psychological analysis, qualities which gave value to his writings on art, but debarred him from success in the department of fiction. His principal novels, *Le Rouge et le Noir*, and *Le Châtroué de Perou*, fell comparatively dead, though the latter was received with extravagant eulogy by Balzac, and has recently become more popular. His genius was too analytic to be suited for romance-writings; the novels want consistency of plot and motive power in the characters. *Le Châtroué*, however, the

best of them, gives an admirable picture of the involved intrigues of a small Italian court, a subject with which Beyle was specially qualified to deal. The peculiar value of all his writings consists in the amount of thinking which they excite, though it must be confessed that the subjects are frequently unworthy of the attention devoted to them. The fullest account of Beyle is that by A. A. Faton, *Henry Beyle, a Critical and Biographical Study*, 1874. See also Colomb's prefaces to *Le Châtroué* and the *Romans et Nouvelles*, Mérimée's preface to the *Correspondance Inédite*, and Sainte-Beuve's articles in the *Causeries du Lundi*.

BEYROUT, BEIROUT, or BAIRUT, the most important seaport town of Syria, on the coast of the Mediterranean, in the pashalic of Acre, 57 miles W.N.W. of Damascus. It is situated on rising ground on the northern side of the promontory of the Jebel-er-Roshah, which forms the spacious bay of St George's, a short distance to the west of the mouth of a stream to which it gives its name—Nahr-Beirut, the ancient Magora. The surrounding hills consist of reddish sand, interspersed with rocks, and covered with a light soil. The roadstead to the N.E. of the town is sheltered from the S.W. wind, but is exposed to the W. and the N.W. The ancient harbour is now choked up, and all that remains of the artificial erections is a pier or causeway at the N.W. extremity of the town, at which boats can discharge. It is supported on arches of unequal size, and is partly constructed of ancient marble columns, many of which still stand along its front, and are used for mooring the lesser vessels. In 1874 the authorities determined to construct a small harbour, and £10,000 was allotted for the purpose. The city proper is an irregular square, open towards the sea, and surrounded on the land sides by a substantial tower-flanked wall, built by Djezzar Pasha. At the N.W. corner are two castellated buildings, built on the rocks. The streets are wider than is usual in Syrian towns, and are paved with large stones; the houses are for the most part lofty and spacious. Formerly, there were deep channels of water flowing down the middle of the streets, but these have been removed. The suburbs of the city, which extend around it with a radius of a mile and a half, are beautifully situated, interspersed with gardens, and planted with fruit trees. During the hot season the wealthy inhabitants remove inland to the villages of Beit-Miry, Brumanah, or Shomlin, on the lower slopes of the Leb'anon. Besides the mosques, bazars, and other native buildings with which it is provided, the city of Beyrout possesses numerous European edifices and institutions. There are six Roman Catholic convents or monasteries, with churches and schools attached, and the sisters of charity maintain an orphanage and hospital. The Prussians support a well-organized school, under the management of a Protestant sisterhood, and the American missionaries have, among other establishments, a hospital and medical school. A girl's school was begun in 1860 by Mrs Thompson, and a ragged school in 1863. A native Christian community has been for some time in existence; and in 1847 a native society of arts and sciences was established. Formerly regarded as the port of Damascus, Beyrout has now become by far the more important of the two cities. It is the seat of various consular establishments, and possesses a quarantine, a custom-house, and post-offices. It exports silk, wool, bitumen, rags, sponges, and skins, and imports European goods for a large part of Syria. In 1871 the value of the exports, which were destined chiefly for France and England, was £530,000; while that of the imports, which were mainly from England and Germany, amounted to £1,240,000. The coasting trade, carried on by small native craft, consists principally of timber, firewood, charcoal, and straw. A lighthouse, 98 feet high, was erected in 1864 on the neighbouring cape of Ras Beyrout. A carriage road was constructed by a French company about 1863, connecting Beyrout with Damascus. An English company con-

pleted in 1874 an extensive system of water-works, by which a large supply is brought from the Nahr-el-Kelb (the Dog River or Lycus), a distance of 9 miles; the aqueduct is taken at one place through a tunnel 1040 yards long, and the water is brought to two reservoirs at the entrance of the town, each of a capacity of 110,000 cubic feet; public fountains, barracks, and mosques are supplied free of charge. The population is of a various character, comprising Druses, Maronites, Greeks, Turks, Arabs, and other races or nationalities. It was greatly increased about 1860 by an immigration of Christian natives who had fled from persecution in Mount Lebanon, Hasbeya, and Damascus. Estimated at only 15,000 in 1838, the number of inhabitants had risen in 1871 to 70,000.

Beirut is a place of great antiquity, and may perhaps be identified with the Berothah of the Phœnicians. For a time at least it was under the supremacy of Sidon. Destroyed by Trypho, the Syrian usurper, about 140 a.c., it was restored by the elder Agrippa about 41 A.D., raised to the rank of a Roman colony, and adorned with an amphitheatre and various splendid buildings. In the 3d century it became the seat of a school of jurisprudence, which long maintained its reputation, and was attended by several eminent men. During the reign of Justinian, in fact, Beirut was the only place in the empire, except Rome and Constantinople, where law was permitted to be taught, and of the three the Syrian school, under the management of Theophilus and Dorotheus, appears to have stood highest in general estimation. But the injury inflicted on the city by an earthquake in 551 led to the removal of the school to Sidon, and not long after the building in which it had been held was totally consumed by fire. In the time of the Crusades Beirut again rose into importance, and was captured by Baldwin I. in 1111, after a two months' siege. Early in the 17th century it became a chief seat of the Druses, who retained their possession till 1768, when it was betrayed into the hands of the Turks. In 1779 it was bombarded and plundered by a Russian fleet, and in 1840 it was nearly destroyed by the attack of the English under Admiral Stopford.

BEZA, THEODORE, or more correctly DE BÈZE, was born at Veselai in Burgundy on the 24th July 1519. His family was of good descent, and his parents were noted for their piety and generosity. While an infant he was adopted by his uncle, Nicholas de Beza, a counsellor of the parliament of Paris, who took his nephew to live with him, and superintended his education with the greatest care. At the age of ten he was put under the tuition of Melchior Wolmar, a German, who resided at Orleans. Beza studied under him for seven years at Orleans and at Bourges, and from him received the impulse which guided his after life. Wolmar, who was an excellent scholar, belonged to the Reformed Church, and his pupil not only learned from him the principles of the Reformed faith, but acquired the habit of diligent and critical study of Scripture. After the return of Wolmar to Germany in 1535, Beza with great reluctance departed for Orleans in order to begin the study of law. His tasks lay altogether in the direction of classics and poetry, and to this period of his life must be referred the composition of many of the licentious poems, the publication of which cost him so much regret, and has brought upon him such calumny. After four years he obtained the degree of licentiate in law, and leaving Orleans, took up his abode in Paris. He was young, ardent, and poetical, of high rank, surrounded with friends, and amply supplied with funds,—for, though he was not in orders, he enjoyed the proceeds of two benefices. It was small wonder that under these circumstances he should have yielded to the temptations of Paris, and have eagerly seized the pleasures that presented themselves. But the extent of his dissipation has been enormously exaggerated; more particularly has his connection with the woman whom he afterwards married been the occasion of calumny and misrepresentation. A severe illness at last recalled to his mind the teachings of his old master Wolmar, and brought clearly before him the contrast his conduct presented to them. Immediately on his recovery, in October 1548, he

retired to Geneva, publicly fulfilled his promise to marry the woman with whom he had formerly lived, and joined the Reformed Church. In the following year he was made professor of Greek at the academy of Lausanne, where he remained for ten years, communicating frequently with Calvin at Geneva. During this time he completed Clement Marot's French translation of the Psalms, and began the extended labours on the New Testament, which resulted in his famous translation and commentary. His veneration for Calvin, already great, was strengthened by closer intercourse; he vigorously defended the execution of Servetus; and in 1558 he gladly removed to Geneva. He was appointed professor of Greek in the academy, and assisted Calvin in his theological lectures. Soon by his vigorous teaching, his numerous writings, and his success in foreign embassies, he came to be looked upon as the most prominent man in the church of Geneva next to Calvin; and after the death of the latter in 1564, he was nominated his successor as teacher of theology, and generally recognized as the leader of the Calvinist party. His enormous activity enabled him not only to manage the internal affairs of the church, and to carry on the important negotiations with France and other powers, but also to compose several theological works of considerable value. Old age did not rob him of his energy; for in 1597 he was able to give a satirical refutation of the story spread about by the Roman Catholics that he had apostatized on his death-bed. He resigned all his official functions in 1600, and died on the 13th October 1605, at the advanced age of 86.

Beza's works were very numerous, and some of them, such as *Histoire ecclésiastique des églises réformées des royaumes de France, Confession, Traductions Théologiques*, are still of value. His reputation, however, rested, and still perhaps rests, on his editions and translations of the New Testament, which did much for the cause of the Reformation. See Schlosser, *Leben des Theodor Beza*, etc., 1809; Baum, *Theodor Beza*, 2 vols., 1842-51 (incomplete). A biography of him was written by one of his favourite pupils, Antoine La Faye.

BÉZIERS, a city of France, in the department of Hérault, the capital of an arrondissement of the same name. It is beautifully situated on a hill, on the left bank of the River Orbe, where it is joined by the Languedoc canal, 38 miles S.W. of Montpellier. It is surrounded by old walls flanked with towers, round which is a promenade planted with trees, and has a fine old Gothic cathedral, Saint Nazaire, dating from the 12th, 13th, and 14th centuries, several churches, an old episcopal palace, now used for the Government offices, a communal college, an agricultural society, a theatre, and a public library. It manufactures silk stockings, starch, gloves, brandy, confectionery, paper, leather, and glass, and has a considerable trade. Béziers is of great antiquity, and has the remains of an amphitheatre, a causeway across the marsh of Cap-estang, and other Roman works. The Romans established a colony there, and it was the headquarters of the seventh legion, under the title of *Beterra Septimanorum*. The present name occurs in the form *Besara* as early as Festus Avianus (5th or 6th century). The town was completely destroyed in 1209 by the forces of Simon de Montfort in the crusade against the Albigenses, on which occasion 60,000 persons were massacred. The walls of the town were rebuilt in 1289; but it again suffered severely in the civil and religious wars of the 16th century, and all its fortifications were destroyed in 1632. Population in 1873, 30,067.

BÉZIQUE, a game at cards (probably from Sp. *besico*, little kiss, in allusion to the meeting of the queen and knave, an important feature in the game). There is a group of card games which possess many features in common. The oldest of these is *mariage*, then follow *brusquembille*, *l'homme de brois*, *briscaux* or *brisque*, and *sing-cent*,

Bésique (also called *beré* and *besigue*) appears to have been founded on these; it is, in fact, *brigue* played with a double pack, and with certain modifications rendered necessary by the introduction of additional cards.

In playing bésique, two packs of cards from which the twos, threes, fours, fives, and sixes have been rejected, are shuffled together and used as one. The packs should have backs similarly coloured or ornamented.

The players cut for deal, and the highest bésique card deals. The cards rank as follows:—Ace, ten, king, queen, knave, nine, eight, seven.

The non-dealer cuts the pack to the dealer, who reunites the separated packets, and deals three cards to his adversary, three to himself, then two to each, and again three to each. The top card of those remaining (called the *stock*) is turned up for trumps. The stock is placed face downwards between the players, and slightly spread. The players then take up the cards dealt to them, and the non-dealer plays any card out of his hand, and the dealer plays a card to it from his hand, the two cards thus played constituting a *trick*. There is no restriction as to the card to be played; the second player need not follow suit, nor win the trick. If he wins the trick by playing a higher card of the suit led, or a trump, the lead falls to him. In case of ties the leader wins. Whoever wins the trick leads to the next; but before playing again each player takes a card from the stock, and adds it to his hand, the winner of the trick taking the top card of those face downwards; and his adversary the next card. This alternate playing and drawing a card each continues until the stock (including the trump card or card exchanged for it, which is taken up last) is exhausted. The tricks remain face upwards on the table, but must not be searched during the play of the hand.

The objects of the play are—1. To promote in the hand various combinations of cards, which when *declared* entitle the holder to certain scores; 2. To win aces and tens; 3. To win the so-called *last trick*.

A declaration can only be made by the winner of a trick immediately after he has won it, and before he draws from the stock. It is effected by placing the declared cards (one of which at least must not have been declared before) face upwards on the table. Declared cards are left face up on the table; but they still form part of the hand, and can be led or played just as though they had not been declared. A player is not bound to declare, although he may win a trick and hold scoring cards. A card led or played cannot be *declared*. More than one declaration may be made to one trick, provided no card of one combination forms part of another that is declared with it. Thus four knaves and a marriage (see table of scores) may be declared at the same time; but a player cannot declare king and queen of spades and knave of diamonds together to score marriage and bésique with those three cards. He must first declare one combination, say bésique; and when he wins another trick he can score marriage by declaring the king. A declaration cannot be made of cards that have already all been declared. Thus, if four knaves (one being a bésique knave) and four queens (one being a bésique queen) have been declared, the knave and queen already declared cannot be declared again as bésique. To score all the combinations with these cards, after the knaves are declared and another trick won, bésique must next be made, after which, on winning another trick, the three queens can be added, and four queens scored. Again, if a sequence in trumps is declared, marriage of the king and queen on the table cannot afterwards take place. To score both, the marriage should be declared first, and after winning another trick the remaining sequence cards should be added. Lastly, a card once declared can only be used again in declaring in combinations of a different class. For example: the bésique queen can be declared in bésique, marriage, and four queens; but having once been declared in single bésique, she cannot form part of another single bésique; having been married once, she cannot be married again; and having taken part in one set of four queens, she cannot take part in another.

The seven of trumps may be either declared or exchanged for the turn-up after winning a trick, and before drawing. When exchanged, the turn-up is taken into the player's hand, and the seven put in its place. The second seven is, of course, declared, as it would be absurd to exchange one seven for another. A seven when declared is not left on the table, but is simply shown.

*Table of Bésique Scores.*

<i>Seven of trumps</i> , <sup>1</sup> turned up, dealer marks .....	10
<i>Seven of trumps</i> , declared or exchanged, player marks ..	10
<i>Marriage</i> (king and queen of any suit) declared .....	20
<i>Royal marriage</i> (king and queen of trumps) declared .....	40

<sup>1</sup> Some players do not turn up a card for trumps, but make the trump suit depend on the first marriage declared. The turning up rule is the best.

<i>Bésique</i> <sup>2</sup> (queen of spades and knave of diamonds) declared .....	40
<i>Double bésique</i> <sup>3</sup> (all the four bésique cards) declared .....	500
<i>Four aces</i> (any four, whether duplicates or not), declared ..	100
<i>Four kings</i> (any four) declared .....	80
<i>Four queens</i> (any four) declared .....	80
<i>Four knaves</i> (any four) declared .....	40
<i>Sequence</i> (ace, ten, king, queen, knave of trumps) declared ..	250
<i>Aces and tens</i> , <sup>4</sup> in tricks, the winner for each one marks ..	10
<i>Last trick</i> , <sup>5</sup> the winner marks .....	10

The winner of the last trick can declare anything in his hand (subject to the limitations with regard to declaring already explained). After this all declarations cease. The winner of the last trick takes the last card of the stock, and the loser the turn up card (or seven exchanged for it). All cards on the table, that have been declared and not played, are taken up by their owners. The last eight tricks are then played, but the rules of play alter. The winner of the last trick leads. The second player must follow suit if able, and must win the trick if able, and if not able to follow suit, he must win the trick if he can by trumping. The winner of the trick leads to the next. The tricks are only valuable for the aces and tens they may contain. If a player revokes in the last eight tricks, or does not win the card led, if able, the last eight tricks belong to his adversary.

When a deal is over, the non-dealer in the previous hand deals, and so on alternately until the game is won by one of the players reaching 1000. All the scores are reckoned by tens, but there is no reason why they should not be reckoned by units, the game in that case being 100 up. The score may be kept by means of a bésique board and pegs, or by a numbered dial and card, or by counters.

**PENALTIES.**—If the dealer gives too few cards the number must be completed from the stock, or the non-dealer, not having looked at his cards, may have a fresh deal.

If the dealer gives his adversary too many cards the player who has too many must not draw until his number is reduced to seven.

If the dealer gives himself too many cards the non-dealer may draw the surplus cards and add them to the stock, unless the dealer has looked at his hand, when he is liable to the penalty for playing with nine cards (*9/17s*).

A card exposed in dealing gives the adversary the option of a fresh deal.

If a player draws out of his turn, and the adversary discovers the error before he draws, he may add 20 to his score, or deduct 20 from his adversary's.

If the winner of a trick when drawing lifts two cards, the adversary may have them exposed, and take his choice. If the loser of a trick lifts two cards, the adversary may look at the one improperly lifted, and at the next draw that card, and the next are turned face up, and the player not in fault has his choice of them.

If a player plays with seven cards his adversary may add 20 to his own score, or deduct 20 from the offender's. The player with a card short must take two cards at his next draw.

If at any time during the play of the hand one player is found to hold nine cards, the other having but eight, the adversary of the player with nine cards may add 200 to his own score, or deduct 200 from the offender's. The player with nine cards must play to the next trick without drawing.

There is no penalty at two handed bésique for exposing a card from the hand, or for leading out of turn. At three or four handed bésique, a card exposed or led out of turn must remain on the table, and nothing can be subsequently declared in combination with it.

<sup>2</sup> When clubs or hearts are trumps, the bésique cards are queen of spades and knave of diamonds. When spades or diamonds are trumps, the bésique cards are queen of clubs and knave of hearts. Some players object to this alteration, but it is a great improvement to the game.

<sup>3</sup> If single bésique is declared first, and then the two other bésique cards added, 500 is scored in addition to the 40 already scored; but if all four are declared together only 500 can be scored, and not 540.

<sup>4</sup> The winner of a trick containing two aces or two tens, or one of each, of course marks 20. The best plan is to score aces and tens immediately they are won; but some players only score them at the end of the hand. When this mode is adopted, the winner of a trick containing an ace or ten takes the tricks on the table and turns them face downwards in front of himself, and after the hand is over looks through his packet to ascertain the number of aces and tens it contains. When scoring in this way it occasionally happens that both players can score out, in which case precedence is given to the winner of the so-called last trick.

<sup>5</sup> The so-called last trick is the last before the stock is exhausted. When two cards of the stock, viz., the trump and another card, remain on the table, the player winning the trick is said to win the last trick, notwithstanding that there are still eight tricks to be played.



When a card is led out of turn, if all the other players play to it, the error cannot be rectified.

**THREE AND FOUR HANDED BÉSIQUE.**—When three play, three packs are used together. All play against each other. The dealer deals to his left; the player first dealt to has the first lead. The rotation of dealing goes to the left. A second double bésique, counting 500, may be declared to a bésique on the table, which has already been used for double bésique. Triple bésique scores 1500. All the cards of the triple bésique must be on the table at the same time and unplayed to a trick. All may be declared together, or a double bésique may be added to a single one, or a third bésique may be added to a double bésique already declared. The game is 2000 up. In playing the last eight tricks, the third hand, if not able to follow suit, nor to win the trick by trumping, may throw away any card he pleases.

When four play, four packs are shuffled together and used as one. The players may score independently, or they may play as partners. A second double bésique or triple bésique may be scored as before; to form them the bésiques may be declared from the hand of either partner. A player may declare when he or his partner takes a trick. In playing the last eight tricks, the winner of the last trick and the adversary to his left play their cards against each other, and then the other two similarly play theirs.

**HINTS TO PLAYERS.**—The following hints, which merely touch on the elements of the play, may assist the beginner:—

The lead is, as a rule, disadvantageous. Therefore do not win the trick unless—(1) you wish to declare; or (2) you wish to make an ace or ten of the suit led; or (3) an ace of a ten is led which you desire to win.

Sevens, eights, and nines in plain suits are valueless. In trumps they should be kept to obtain the lead with. It is very important to keep one small trump in hand if possible. Knives also are of but little value (except bésique and trump knives), and may be thrown away freely.

It is of more importance to win aces and tens or to make tricks with them than at first sight appears. Experienced players prefer a number of small scores to sacrificing them for the chance of a large one. Therefore it is not considered good play as a rule to go for four aces unless you have three, and are in no difficulty as to your play. Rather make tricks with the aces, and especially capture tens with them. Whenever you are second player, and can win a trick with a ten, take it, except in trumps, of which the ten is kept for sequence.

When in difficulties, lead an ace or a ten in preference to a king or queen. As a rule, if you try for aces, you have to sacrifice some other score, and are pretty sure to lose some of the aces after declaring them.

If driven to lead an ace or a ten, and your opponent does not win it, lead another.

Endeavour to recollect in what suits the aces and tens have been played, so that, when leading, you may choose suits of which the most aces and tens are out. Similarly, if your adversary declares aces, avoid leading the suits of the declared aces; and, in discarding, retain those cards which are least likely to be taken by aces and tens.

Having a choice between playing a possible scoring card, or a small trump, or a card that you have declared, generally play the last so as to conceal your hand.

Do not part with a sequence card early in the hand, even if you have a duplicate, as playing it shows that you are likely to hold the duplicate, and you thus free your opponent's game, as he will immediately use his trump sequence cards to win all the aces and tens you lead.

Also, do not part with bésique cards until near the end of the hand, even after declaring bésique, because by so doing you give up all chances of double bésique. If you draw or hold a third bésique card, sacrifice everything, even sequence cards, for the chance of a double bésique.

Avoid declaring combinations which show your adversary that he cannot make sequence or double bésique. By keeping him in the dark you hamper his game, and are very likely to cause him to refrain from trumping your aces or tens. For example, if early in the hand you hold two trump queens and two bésique queens, you should postpone declaring them as long as possible, or even sacrifice the score altogether.

You may often judge during the play of the hand what combinations your adversary is going for. Thus, if he discards kings he is probably strong in queens, and *vice versa*. If in doubt as to whether you should keep kings or queens, you of course choose the combination he is not trying for. With attention and experience it is surprising how much may be inferred as to your adversary's game, and how greatly your own line of play may be thus directed.

It is as a rule right to win the last trick, in order to prevent the adversary from declaring, for which purpose lead the ace of trumps. When within a few tricks of the end of the hand, you may often prevent your opponent from scoring sequence by leading out your high trumps.

In playing the last eight tricks your object is simply to make as many aces and tens as you can, and to win those of your adversary.

**POLISH BÉSIQUE** (also called *Open Bésique* and *Fidd'sicks*) differs from ordinary bésique in the following particulars:—

Whenever a scoring card is played, the winner of the trick places it face upwards in front of him (the same with both cards if two scoring cards are played to a trick), forming rows of aces, kings, queens, knaves, and trump tens (called *open cards*). Cards of the same denomination are placed overlapping one another lengthwise from the player towards his adversary to economise space. When a scoring card is placed among the open cards, all the sevens, eights, nines, and plain suit tens in the tricks are turned down. Open cards cannot be played a second time, and can only be used in declaring. Whether so used or not they remain face upwards on the table until the end of the hand, including the last eight tricks. A player can declare after winning a trick and before drawing again, when the trick won contains a card or cards, which added to his open cards complete any combination that scores. Every declaration must include a card played to the trick last won. Aces and tens must be scored as soon as won, and not at the end of the hand. The seven of trumps can be exchanged by the winner of the trick containing it; and if the turn-up card is one that can be used in declaring, it becomes an open card when exchanged. The seven of trumps when not exchanged is scored for by the player winning the trick containing it.

*Compound declarations* are allowed, *i.e.*, cards added to the open cards can at once be used, without waiting to win another trick, in as many combinations of different classes as they will form with the winner's open cards. For example: A has three open kings, and he wins a trick containing a king. Before drawing again he places the fourth king with the other three, and scores 80 for kings. This is a simple declaration. But suppose the card led was the queen of trumps, and A wins it with the king, and he has the following open cards—three kings, three queens, and ace, ten, knave of trumps. He at once declares royal marriage (40); four kings (80); four queens (80); and sequence (260); and scores in all, 480. Again: ace of spades is turned up, and ace of hearts is led. The second player has two open aces, and wins the ace of hearts with the seven of trumps and exchanges. He scores for the exchange, 10; for the ace of hearts, 10; for the ace of spades, 10; and adds the aces to his open cards, and scores 100 for aces; in all, 130. If a declaration or part of a compound declaration is omitted, and the winner of the trick draws again, he cannot amend his score.

The ordinary rule holds that a second declaration cannot be made of a card already declared in the same class. Thus: a queen once married cannot be married again; a fifth king added to four already declared does not entitle to another score for kings.

The fundamental point to be borne in mind is, that no declaration can be effected by means of cards held in the hand. Thus: A having three open queens and a queen in hand cannot add it to his open cards. He must win another trick containing a queen, when he can declare queens.

Declarations continue during the play of the last eight tricks just the same as during the play of the other cards.

The game is 2000 up. After each deal it is advisable to shuffle thoroughly; otherwise a number of small cards will run together in the stock, and impair the interest of the game. It is also advisable to adopt the change in the bésique cards recommended for ordinary bésique, otherwise the scores of one hand may run very high, and of the other very low, which spoils the game. The lead is even more disadvantageous than at ordinary bésique. It is important not to lead cards that can be won by bésique cards. It is often advisable to win with a high card though able to win with a low one; thus having king, nine of a suit of which the eight is led, if you win the trick, you should take it with the king. It is not of so much consequence to win aces and tens (especially the latter) as at ordinary bésique. It is a difficult point in the game to decide whether to win tricks with sequence cards, on the chance of eventually scoring sequence, or to reserve trumps for the last eight tricks. As a rule, if the hand is well advanced, and you are badly off in trumps, win tricks with sequence cards, and especially if you have duplicate sequence cards make them both. If badly off in trumps towards the end of a hand, and your adversary may win double bésique, keep in hand an ace or ten of the bésique suits, as when it comes to the last eight tricks (in which suit must be followed), you may prevent the score of double bésique.

**GRAND BÉSIQUE** (also called *Chinese Bésique*) is played like ordinary bésique, except as follows:—

Four packs are shuffled together and used as one, and nine cards are dealt to each player, by three at a time to each. When a combination is declared, and one of the cards composing it is played away, another declaration can be completed (after winning a trick) with the same cards. Thus: A declares four aces, and uses one to win a trick, or throws one away. A has a fifth ace in hand and wins a

trick, he can add it to the three remaining declared aces, and score four aces again, and so on. Marriages can be declared over and over again; thus king, queen of hearts are declared, and the player draws another king of hearts. He plays, the declared king and wins the trick, he can then marry the queen again. Some players object to this, calling it bigamy; but if only permitted after the declared king is played, it is not bigamy, but the marriage of a widow. Bézique follows the same rule: if, say, the knave is played away, another knave makes another bézique; and so on with double and triple bézique, if the former declared cards which remain unplayed can be matched from cards in hand to make the requisite combinations. Sequence can be declared over and over again, and compound declarations made among the declared cards are now generally allowed. The sevens of trumps do not count, nor does the last trick, or at all events these only count by agreement. The game is 3000 up. The great points to aim at are to declare four aces or sequence, which can then be declared over and over again, if fresh aces or sequence cards are taken into hand (the duplicate sequence cards being first played away). With fair chance of sequence everything else, even aces or chance of double bézique, should be sacrificed. (H. J.)

**BHÁGALPUR**, a division or commissionership of British India, under the Lieutenant-Governor of Bengal, comprising the districts of Bhágálpur, Monghir, Santál Parganá, and Purniah, lies between 23° and 27° N. lat., and 85° and 89° E. long. It is bounded on the N. by the independent state of Nepal and the British district of Darjiling; on the E. by the districts of Jalpaiguri, Dinájpur, Málidah, Murshidábád, and Birbhám; on the S. by the districts of Birbhám, Mánbhám, and Hazárbágh; and on the W. by the districts of Gayá, Patná, and Tírhut. According to the census report of 1872, Bhágálpur division contained an area of 18,685 square miles, with a total population of 6,613,358 (i.e., 354 to the square mile), inhabiting 19,247 villages and 1,801,497 houses. Of this population, 4,925,714, or 74·5 per cent., are Hindus; 1,121,630, or 17·0 per cent., Mahometans; 2469 Christians; 53 Buddhists; 563,492, or 8·5 per cent., of unspecified religion, chiefly consisting of aboriginal tribes.

**BHÁGALPUR**, a district of British India in the division of the same name, under the Lieutenant-Governor of Bengal, situated between 26° 35' 30" and 24° 32' 39" N. lat., and 87° 33' 51" and 86° 21' 32" E. long. It is bounded on the N. by the independent state of Nepal, on the E. by the districts of Purniah and the Santál Parganá, on the S. by the Santál Parganá and Hazárbágh, and on the W. by the districts of Monghir and Tírhut. Bhágálpur is a long and narrow district, divided into two unequal parts by the River Ganges. In the southern portion of the district the scenery in parts of the hill-ranges and the highlands which connect them is very beautiful. The hills are of the primary formation, with fine masses of contorted gneiss. The ground is broken up into picturesque gorges and deep ravines, and the whole is covered with fine forest trees and a rich undergrowth. Within this portion also lie the lowlands of Bhágálpur, fertile, well planted, well watered, and highly cultivated. The country north of the Ganges is level, but beautifully diversified with trees and verdure. Three fine rivers flow through the district—the Ganges, Kusá, and Ghagrí. The Ganges runs a course of 60 miles through Bhágálpur, is navigable all the year round, and has an average width of three miles. The Kusá rises in the Himalayas and falls into the Ganges near Colgong (Kahlgón), within Bhágálpur. It is a fine stream, navigable up to the foot of the hills, and receives the Ghagrí eight miles above its debouchure.

The census of 1872 disclosed a population of 1,826,290 souls, inhabiting 2739 towns or villages; and 329,372 houses, giving an average of 422 per square mile, 667 per village, and 5·6 per house. Of the total population, 1,689,949, or 89·8 per cent., are Hindus; 169,436, or 9·3 per cent., Mahometans; 532 Christians; 19 Buddhists; 16,364, or 0·9 per cent., of unspecified religions, chiefly of aboriginal tribes, consisting of hillmen, Náts, Santáls, &c. In the early days of British administration these hill-people gave much trouble. They were the original inhabitants of the country whom the Aryan

conquerors had driven back into the barren hills and unhealthy forests. This they avenged from generation to generation by plundering and ravaging the plains. The efforts to subdue or restrain these marauders proved fruitless, till Augustus Cleveland, the collector of Bhágálpur in the latter half of last century, won them by mild measures, and successfully made over the protection of the district to the very hill people who a few years before had been its scourge. Rice, wheat, barley, oats, Indian corn, various kinds of millet, pulses, oil-seeds, tobacco, cotton, indigo, opium, flax and hemp, and sugar-cane, are the principal agricultural products of Bhágálpur district. The jungles afford good pasturage in the hot weather, and abound in lac, silk cocoons, catechu, resin, and the *malud* fruit, which is both used as fruit and for the manufacture of spirits. Iron, gold, coal, and building stone are found, but no iron or coal is at present smelted or worked. Gold is washed from the river sand in small particles. Silk cloth, called *tasar*, and pots similar to Chinese ware, are the principal manufactures of Bhágálpur. Principal seats of trade—Bhágálpur, Ghoghá, Colgong (Kahlgón), Pírpáint, and Sultárganj on the East Indian Railway; Umárpur, Purná, Chándpúr, Belhar, Jaipur, Katará, Babápur, Panjwárá, and Chandan, in the south of the district; and Bihpur, Krishnaganj, Muraliganj, and Prátárganj north of the Ganges. Besides nine principal roads with a total length of 363 miles, which form the means of external and internal communication, 62 miles of the East Indian Railway connect Bhágálpur with Calcutta and Upper India. For administrative purposes Bhágálpur district is divided into four magisterial subdivisions, viz., the headquarters subdivision, and those of Bání, Madhupur, and Supal; and for police purposes into twelve *thánás*. A regular police, 600 strong, was maintained in 1872 at a total cost of £9569, or an average of one man to every 7·06 square miles, and 2979 of the population. Besides the regular police there were, in 1872, 3666 village watchmen, supported at an estimated cost of £5700, paid by the landholders and villagers, exclusive of the service lands which they enjoy rent free. The total net revenue of the district, in 1870-71, amounted to £189,545, of which £72,161, or 37·71 per cent., was derived from the land; expenditure, £22,570. For the education of the people there were, in 1872, 14 Government and aided schools, attended by 876 pupils, and maintained at a total cost of £2313, of which Government contributed £929. The unaided schools numbered 314, attended by 3593 pupils. The climate of Bhágálpur partakes of the character both of the deltaic districts of Bengal and of the districts of Behar, between which it is situated. The hot season sets in about the end of March, continues till the beginning of June, the temperature at this time rising as high as 110° Fahr. The rains usually begin at the end of June and last till the middle of September; average annual rainfall, 55 inches. The cold season commences at the beginning of November and lasts till March. During December and January the temperature falls as low as 41° Fahr. The average annual temperature is 76°. Bhágálpur formed a part of the ancient Sanskrit kingdom of Anga. In later times it was included in the powerful Hindu kingdom of Magadha or Behar, and in the 7th century A.D. it was an independent state, with the city of Champá for its capital. It afterwards formed a part of the Mahometan kingdom of Gaur, and was subsequently subjected by Akbar, who declared it to be a part of the Delhi empire. Bhágálpur passed to the East India Company by the grant of the Emperor Sháh Alam in 1765. (W. W. E.)

**BHÁGALPUR**, the principal town of the district and division of the same name, situated on the right bank of the Ganges, here seven miles wide, in 25° 11' N. lat. and 87° E. long. The town is two miles in length and a mile in width, but lies in a low, open valley, and consists of scattered market-places meanly built. Its most interesting objects are two ancient round towers, each about 70 feet high. Adjacent to the town are the two Cleveland monuments, one erected by Government, and the other by the Hindus, to the memory of the civilian, who, at the end of last century, "by conciliation, confidence, and benevolence, attempted and accomplished the entire subjection of the lawless and savage inhabitants of the Junglery of Rájmahal." Bhágálpur is the headquarters of the commissioner of the division and of the judge and collector of the district; it is also a station of the East Indian Railway. Its Government school was attended by 361 pupils in 1872. In the same year the town contained a population of 69,678 souls, of whom 50,673, or 72 per cent., are Hindus; 18,455, or 26 per cent., Mahometans; 19 were Buddhists, 342 Christians, and 189 unclassified. Municipal income, in 1872, £2951, 6s.; expenditure, £3470, 14s.; incidence of municipal taxation, 10½d. per head of the town population.

**BHAMO**, or **BANMO** (in Chinese, **THINGGAI**), a city of Upper Burmah, situated in 24° 16' N. lat. and 95° 54' 47" E. long., on the left bank of the Irawady, a short distance below its confluence with the Tapeng, and about 300 miles up the river from Mandalay the capital. It was formerly a very flourishing city, and the chief town of a Shan principality; and though greatly decayed, it is still the seat of a Burmese governor and the centre of a considerable trade. At the time of Dr John Anderson's visit in the year 1868 (*Expedition to Western Yunnan*, 1871), it consisted of about 500 houses of sun-burnt brick, and had an estimated population of 2500, partly Shans and partly Chinese. The latter possess a temple and theatre, and there were remains of ancient pagodas and other buildings. In the neighbourhood are ruins of two cities, called Tsam-penago, both of considerable extent. Special attention has been directed to Bhamo as an important position for the development of commerce between British India and Western Yunnan, no fewer than four practicable routes leading eastward from the city to Momein.

**BHANDÁRÁ**, a district of British India, under the jurisdiction of the Chief Commissioner of the Central Provinces, situated between 20° and 22° N. lat., and 79° and 81° E. long. It is bounded on the N. by the districts of Seoni and Balághát, on the E. by the district of Raipur, on the S. by the district of Chándá, and on the W. by the district of Nágpur. To the north, north-east, and east, a natural boundary line is marked out by lofty hills, inhabited by Gonds and other aboriginal tribes, while the west and north-west are comparatively open. Small branches of the Sâtpurá range make their way into the interior of the district. The Ambagarh, or Sendurjharí hills, which skirt the south of the Chandpur parganá, have an average height of between 300 and 400 feet above the level of the plain. The other elevated tracts are the Baláhi hills, the Kanherí hills, and the Navegón hills. The Waingangá is the principal river in the district, and the only stream that does not dry up in the hot weather,—its affluents within the district being the Bâwantharí, Bághnadí, Kanbán, and Chulban. There are 3648 small lakes and tanks in Bhandará district, whence it is called the "lake region of Nágpur;" they afford ample means of irrigation. More than one-third of the district lies under jungle, which yields gum, medicinal fruits and nuts, edible fruits, lac, honey, and the blossoms of the *mabusú* tree (*Bassia latifolia*), which are eaten by the poorer classes, and used for the manufacture of a kind of spirit. Tigers, panthers, deer, wild hogs, and other wild animals abound in the forests, and during the rainy season many deaths occur from snake-bites.

Bhandará district contains an assessed area of 8148.61 square miles, or 2,018,114 acres, of which 819,922 acres were under cultivation in 1869; 30,846 acres, grazing lands; 550,922 acres, cultivable but not under cultivation; and 618,425 acres uncultivable waste. The census of 1872 gave the total area of the district at 3922 square miles, and returned the population at 864,819 (144 to the square mile), residing in 106,121 houses and 1589 villages. Of the total population, 472,151, or 88.90 per cent., were Hindus; 10,696, or 1.39 per cent., Mahometans; 520 Buddhists or Jains; 61 Christians; and 81,379, or 14.41 per cent., were aboriginal tribes of unspecified religion. The Hindu population is chiefly divided into the following castes:—Bráhmans, "Pardás," or foreigners (generally Rájpúts), Pôwáras, Lodhás, Kunbás, Korás, Kalás, Telás, Dhímáras, Koshás, Goárás, and Dháras. The inhabitants are rude and unpolished in their manners, and slothful in their habits. The agricultural products of the district consist of rice, wheat, grain, pulses, peas, sugar-cane, oil-seeds, and cotton; the following being an estimate of the acreage under different crops:—rice, 543,019 acres; wheat, 86,064; other food grains, 147,983; oil-seeds, 27,068; sugar-cane, 12,561; fibres, 197; tobacco, 558; and vegetables, 2128 acres—total, 819,477 acres, or 1280.43 square miles. Iron is the chief mineral product. Gold is also found in the bed of the Son Nadi, but does not repay the trouble of searching for it. Laticite, shale, and sandstone occur all over the district—the largest quarries being near Bhandará town, at Korambí, and in the Baláhi hills. Native cloth, brass wares, pot-stone wares, cart-

wheels, straw and reed baskets, and a small quantity of silk, form the only manufactures of the district. Cotton, salt, wheat, rice, oil-seeds, hardware, English piece goods, tobacco, silk, dyes, and cattle, are its chief articles of import; and country cloth, tobacco, and hardware its exports. The Great Eastern Road is the only well-raised, bridged, and metalled road in the district; but there are also five or six second-class roads, unmetalled and unbridged, but levelled, and sloped at the crossings of water-courses. The revenue demand for 1868-69 amounted to £40,396, 8s. from land, £5692, 2s. from excise, £3774, 18s. from stamps, £2553, 10s. from forests, £5051, 10s. from assessed taxes—total, £57,268, 8s. The regular police force of 443 men was maintained in 1868 at a cost of £5584, 10s., exclusive of the village watch. In 1868 the district contained 38 Government and 78 private schools, affording instruction to 7109 boys and 215 girls. Four towns have upwards of 5000 inhabitants: (1.) Bhandará—population, 11,433; municipal income, £486; expenditure, £646, 6s.; rate of taxation, 10½d. per head; (2.) Tumsal—population, 7867; municipal income, £1305; expenditure, £554, 10s.; rate of taxation, 3s. 6½d. per head; (3.) Mohárí—population, 6183; municipal revenue, £198; expenditure, £344, 2s.; rate of taxation, 7½d. per head; (4.) Páuní—population, 8976; municipal revenue, £174, 10s.; expenditure, £383, 18s.; rate of taxation, 4½d. per head. Bhandará district contains 25 semi-independent chiefships, having an area of 1599 square miles, and a population of 166,005 souls in 1866. These little states are exempted from the revenue system, and only pay a light tribute. Their territory, however, is included within the returns of area and population above given. The climate of Bhandará is unhealthy,—the prevailing diseases being fever, small-pox, and cholera. Nothing is known of the early history of the district. Tradition says that at a remote period a tribe of men, called the Gauh or Gaulars, overran and conquered it. At the end of the 17th century it belonged to the Gond Rájá of Deogarh. In 1788 it was conquered by the Marhattás, who governed it till the year 1854, when it lapsed to the British Government, the Rájá of Nágpur having died without an heir.

**BHANDÁRÁ**, the principal town and headquarters of the district of the same name, is situated on the Waingangá, about 38 miles east of Nágpur. The town is kept neat and clean, is well drained, and is considered healthy. In 1872 it contained a total population of 11,433 souls, of whom 9657 were Hindus, 1450 Mahometans, 58 Buddhists and Jains, 54 Christians, and 214 of unspecified religion. For income, &c., see above. The town enjoys a considerable trade in cotton cloth and the local hardware.

**BHANG**, an East Indian name for the hemp plant, *Cannabis sativa*, but applied specially to the leaves dried and prepared for use as a narcotic drug. The hemp plant, as cultivated in the Bengal Presidency and the North-West Provinces, yields a peculiar resinous exudation, which is altogether wanting in the hemp grown on account of its fibre in European countries. For this resinous exudation, in which its virtues as a drug reside, hemp is cultivated in Kashmir, Bokháras, Yarkand, and Central Asia generally, besides North India, and in certain parts of East Africa, where, according to Captain Burton, it is grown "before every cottage door." In India the products of the plant for use as a narcotic and intoxicant are recognized under the three names and forms of Bhang, Gunja or Ganja, and Churrus or Charas. Bhang consists of the larger leaves and capsules of the plant on which an efflorescence of resinous matter has occurred. The leaves are in broken and partly agglutinated pieces, having a dark-green colour and a heavy but not unpleasant smell. Bhang is used in India for smoking, with or without tobacco; it is prepared in the form of a cake or manjan, and it is made into an intoxicating beverage by infusing in cold water and straining. Gunja is the flowering or fruit-bearing tops of the female plants. It is gathered in stalks of several inches in length, the tops of which form a matted mass, from the agglutination of flowers, seeds, and leaflets by the abundant resinous exudation which coats them. Churrus is the resinous substance separated from the plant. According to Dr O'Shaughnessy it is obtained by men dressed in leathern aprons brushing forcibly through the growing stalks, and the resin which thereby adheres to the leather is scraped off with knives. It is stated that in Nepal the

leather covering is dispensed with, and the resin gathered on the naked bodies of coolies, who brush through the standing stalks. Dr Royle says, "the glandular secretion is collected from the plants on the hills by the natives pressing the upper part of the young plants between the palms of their hands, and scraping off the secretion which adheres." The preparation known as hashish among the Arabs is similar to the gunje of India, and is used in the same manner. The use of preparations of hemp among the Mussulman and Hindu population of India is very general; and the habit also obtains among the population of Central Asia, the Arabs, and Egyptians, extending even to the negroes of the valley of the Zambesi and the Hottentots of South Africa. The habit appears to date from very remote times, for Herodotus says of the Scythians, that they creep inside huts and throw hemp seeds on hot stones. The seeds "soon send forth a virulent intoxicating smoke, which fills the close tent, and the people inside, being overpowered with the intoxicating effects, howl with excitement and delight." The observations of Dr O'Shaughnessy on the effects of the drug on the native population of India led him to conclude that it alleviates pain, and causes a remarkable increase of appetite, unequivocal aphrodisia, and great mental cheerfulness. Its violent effects are delirium of a peculiar kind, and the production of a cataleptic condition. Sir Robert Christian says, that "for energy, certainty, and convenience, Indian hemp is the next anodyne, hypnotic, and antispasmodic to opium and its derivatives, and often equal to it." Preparations are used in British pharmacy in the form of tincture and extract prepared from gunje, and it is understood to form an ingredient in the patent medicine chlorodyne.

**BHARAICH**, a district of British India, under the jurisdiction of the Chief Commissioner of Oudh, situated between 28° 23' and 27° 4' N. lat., and 82° 11' and 81° 9' E. long. It is bounded on the N. by the independent state of Nepal, on the E. and S.E. by the district of Gondá, on the S.W. by the district of Bára Báñki, and on the W. by the districts of Sitápur and Kherá. Bharáich district consists of three tracts:—(1), in the centre, an elevated triangular plateau, projecting from the base of the Himaláyas for about 50 miles in a south-easterly direction—average breadth 13 miles, area 670 square miles; (2), the great plain of the Ghagrá, on the west, about 40 feet below the level of the plateau; and (3), on the east, another lesser area of depression. The *Tardá*, or the forest and marshy tracts along the southern slopes of the Himaláyas, gradually merge within the district into drier land, the beds of the streams become deeper and more marked, the marshes disappear, and the country assumes the ordinary appearance of the plain of the Ganges. The Ghagrá skirts the district for 114 miles; and the Raptá, with its branch the Bhaklá, drains the high grounds.

District area, 2398 square miles, since the redistribution of territory in 1869; prior to this its area was 2682 square miles. In 1872 the district contained a total population of 774,640 souls, residing in 121,903 houses and 1966 villages; of which 674,313 were Hindus, 98,124 Mahometans, and 40 Christians, and the rest of unclassified religions. Of the Hindu population the Brahmins number 71,215; Kshatriyas, 20,514; Ahirs, 91,479; Chámáras, 56,329; Kurmá, 79,723. Principal crops and estimated acreage:—rice, 167,000 acres; Indian corn, 76,000; wheat, 78,000; barley, 84,000; and rape-seed, 26,000 acres. Besides these, other kinds of oil-seeds, pulses, sugar, cotton, opium, indigo, fibres, tobacco, and vegetables are also cultivated. Total assessed area of the district, 1,348,104 acres; of which 836,441 are under cultivation, 511,663 cultivable grazing land, and 187,347 uncultivable waste. Land tax, £114,507; rate per cultivated acre, 2s. 6d. Of the population 495,761 are agriculturists, and 278,889 non-agriculturists. There are no manufactures of any note in the district, but each large village has its little colony of weavers, and stockings are made in Bharáich and Nánpará. Revenue in 1871, £180,000; of which £116,000, or 65 per cent., was derived from the land. District civil expenditure, £10,147. The last land revenue settlement was completed in 1871,

and expires at different periods between 1897 and 1901. The regular police number, besides the village watch, 465 men, maintained at a cost of £5850. Education is backward. The central school at Bharáich has 105 pupils; and 8 Anglo-vernacular, with 41 vernacular village schools throughout the district, have 1649 pupils. Principal towns:—(1.) Bharáich, built on the extreme edge of the plateau described above, where it sinks sharply down upon the plains of Oudh; height above sea-level, 480 feet; population, 18,889; municipal income in 1871, £2177, 14s.; rate of taxation, 2s. 3½d. per head; (2.) Nánpará, population, 6858; municipal income in 1871, £337, 8s.; rate of taxation, 11½d. per head; (3.) Jaina, population, 4510.

**BHARTPUR**, or **BHURTPORE**, a native state of Rájputáná in Upper India, under the political superintendence of the British Government, lying between 26° 48' and 27° 50' N. lat., and 76° 54' and 77° 49' E. long. It is bounded on the N. by the British district of Gurgón, on the N.E. by Mathurá, on the E. by Agra, on the S. and S.W. by the Rájput states of Karauli and Jaipur, and on the W. by the state of Alwar. Length from north to south, about 77 miles; greatest breadth, 50 miles; area, 1974 square miles. The country is generally level, about 700 feet above the sea. Small detached hills, rising to 200 feet in height, occur, especially in the northern part. These hills contain good building stone for ornamental architecture, and in some of them iron ore is abundant. The *Bangangá* is the only river which flows through the state. It takes its rise at Manoharpur in the territory of Jaipur, and flowing eastward passes through the heart of the Bhartpur state, and joins the *Jamná* below Agra.

In 1871-72 the population of Bhartpur amounted to 743,710 souls, consisting chiefly of Játs professing Hinduism, to which tribe the Rájá or chief of the state belongs. The Játs are one of the ancient Indo-Germanic races of India; by religion, Mussulmans in the west of Hindústan, Hindus in the east, and Sikhs in the Panjáb. The Játs make excellent cultivators, hardworking, thrifty, and energetic in the arts of peace as in those of war. Principal crops:—wheat, Indian corn, cotton, pulses, and sugar. The want of water is much felt; but the soil, though in many places sandy, is rendered highly productive by well-irrigation. The saline tracts yield salt of an inferior quality. Chief routes:—Mathurá to Mhas (Mhow) via Bhartpur town; Mathurá to Nadríbid, through Bhartpur town; Mathurá to Alwar, through Dig town; Agra to Ferozpur, through the towns of Bhartpur, Dig, and Kumbher; Agra to Ajmir, by *Wáser*. Principal towns:—Bhartour, Dig, *Wáser*, Kumbher, and Bhaná.

Bhartpur rose into importance under Súraj Mall, who bore a conspicuous part in the destruction of the Delhi empire. Having built the forts of Dig and Kumbher in 1730, he received in 1756 the title of Rájá, and subsequently joined the great Marhattá army with 30,000 troops. But the misconduct of the Marhattá leader induced him to abandon the confederacy, just in time to escape the murderous defeat at Páñiput. Súraj Mall raised the Ját power to its highest point; and Colonel Dow, in 1770, estimated the Rájá's revenue (perhaps extravagantly) at £2,000,000, and his military force at 60,000 or 70,000 men. In 1803 the East India Company concluded a treaty, offensive and defensive, with Bhartpur. In 1804, however, the Rájá assisted the Marhattás against the British. The English under Lord Lake captured the fort of Dig and besieged Bhartpur, but was compelled to raise the siege after four attempts at storming. A treaty, concluded on 17th April 1805, guaranteed the Rájá's territory; but he became bound to pay £200,000 as indemnity to the East India Company. A dispute as to the right of the succession again led to a war in 1825, and Lord Combermere captured Bhartpur with a besieging force of 30,000 men, after a desperate resistance, on the 18th January 1826. The fortifications were dismantled, the hostile chief being deported to Benares, and an infant son of the former Rájá installed under a treaty favourable to the Company. In 1853 the Bhartpur ruler died, leaving a minor heir. The state came under British management, and the administration has been improved, the revenue increased,

a system of irrigation developed, new tanks and wells constructed, and an excellent system of roads and public buildings organized. In 1871-72 the revenue of the Bhatpur state amounted to £261,957. For educational purposes one college and 147 schools, with 3908 students, are maintained at an annual expenditure of £1831. The military force of the state consists of 1500 cavalry, 1500 infantry, and 200 artillery. The police force numbers 2200 men. Owing to the hot winds blowing from Rāj putānā, the climate of Bhatpur is extremely sultry till the setting in of the periodical rains. Bhatpur city, the capital, lies in 27° 12' N. lat. and 85° 49' E. long.

**BHATGĀON**, a town of Northern India, in the Nepāl valley, situated in 27° 37' N. lat. and 85° 22' E. long. It is a celebrated place of Hindu superstition, the favourite residence of the Brāhmins of Nepāl, and contains more families of that order than either Kātmāndu or Patu. It contains 12,000 houses, and its palace and buildings generally are of a more striking appearance than in other Nepālese towns. The town is said to possess many Sanskrit libraries.

**BHATNIĀR**, or **BEATHIS**, a people of the northern part of Hindustān, inhabiting the tract of country now included within the British district of Hissar, formerly called Bhatniān, the eastern frontier of which is situated 125 miles north-west of Dehli. The Bhattis present many peculiarities in manners and customs, distinguishing them from the other people of Hindustān. They consist of two distinct races—the one being composed of Mahometans of Rājput descent, who constitute the influential class, and who report among themselves that their ancestors emigrated some centuries ago from the district of Jasalmīr, and after various vicissitudes settled in the Bhatniār country; the other comprising the common people, known as Jāts, who have adopted the religion of their superiors, and are consequently treated with great moderation. Most of these people are descended from dwellers on the western bank of the Satlej, who were invited by a Rājā of the Bhattis to cross the river and settle in his country. Though tillers of the soil, the Bhattis are more generally characterized as shepherds; and though they are mostly restricted to the territory whence their name is derived, various tribes of them are to be found in the Panjāb, and they are also scattered over the high grounds to the east of the Indus.

Notwithstanding they are Mahometans, their customs are in some respects at variance with those observed by the majority of the followers of the prophet, particularly in the females appearing, without reserve, unveiled in public, and in their associating openly with the men. The wives of the Rājput chiefs form an exception.

The territory above described, anterior to British sway, was under the dominion of a prince or Rājā, whose authority was acknowledged by inferior chiefs. This potentate could bring 20,000 or 30,000 men into the field, but they were quite undisciplined, and despised the necessary principle of subordination. His revenue arose chiefly from the plunder his troops secured; for their wars were directed more to predatory purposes than to open contest, and the Rājā, instead of repressing the ravages of this immense banditti, willingly participated in the spoils.

While under the influence of native rule the Bhattis appear to have formed a collection of hordes of freebooters. They have been described as of a cruel, savage, and ferocious disposition, entertaining an abhorrence of the usages of civilized life—thieves from their earliest infancy, and during their predatory incursions into the neighbouring districts, not scrupling, though unresisted, to add murder to robbery.

Many of the Bhattis appear to be constantly changing their residence from place to place as subsistence fails.

Their exports are horses, camels, bullocks, Buffalo, and ghi; occasionally they sell some surplus grain above what is necessary for their own consumption, but their traffic is very inconsiderable. A large portion of the country is unproductive, but along the banks of the River Ghāgar, from Bhatniār to the town of Sīrā, and also in the vicinity of the Naiwāl (Nālā, or watercourse), the soil is uncommonly rich, and well adapted for cultivation. The inundations of these rivers fertilize their banks, and the subsidence of the waters leaves a broad margin prepared for plentiful crops of wheat, rice, and barley, which amply reward the labours of the husbandman.

The former capital of the Bhattis was Bhatniār, which lies in a situation almost inaccessible to an enemy, for no water is to be procured within 12 miles but what supplies the inhabitants. It was taken, however, in 1398 by Timur, more recently by the military adventurer George Thomas, and finally in 1805 by the Rājā of Bikānir, who still retains authority over it. The principal town is Sīrā, between which and Bhāwalpur a route for commercial purposes has been opened. Numbers of the Bhattis have emigrated from their native country to establish themselves in the western parts of the dominions of Oudh; and several families of them are to be met with in Rohilkhand. They are practised travellers, and well trained to emigration by the laborious journeys undertaken in crossing the great desert to the west of their territories. During the independence of their native rulers, expeditions were frequently made in large parties for the purpose of predatory incursions on peaceable countries more remote; and these banditti displayed both skill and determination in attaining their object. Camels previously laden with provisions were despatched to different stations in the desert, which is about 130 miles in breadth, and their loads deposited there. The most intelligent of the party about to follow were then selected as guides, and enforced the most implicit obedience on their companions during the journey, which closed at the frontier of the hostile country, or rather that against which their hostility was directed. The guides by long experience became expert without compass or landmark, and seldom failed to conduct the party to the appointed station where the provisions were deposited, and thence across the remainder of the desert in safety. If accidentally they missed the points of rendezvous, or those where alone their necessities could be relieved, they were exposed to inevitable destruction. The adventurers steered their course by the sun in the day-time, and by the polar star at night; and by similar aids they were enabled to retrace the way they had travelled.

The history of the Bhattis has attracted the notice of few European authors. They seem to have carried on frequent wars with neighbouring states, and were the most formidable enemies opposed to the Rājā of Bikānir. The latter, however, invaded their territories in the beginning of the present century, and obtained some temporary advantages. He erected a fortress in Batinda, now a possession of the Rājā of Patāliā, and this contributed to overawe them for a time, and repress their incursions into his own dominions, as, independently of the garrison, he stationed a large body of cavalry in the fort, whose frequent sallies and captures of cattle annoyed the Bhattis so much that they contemplated a total emigration from their own country. But George Thomas, the military adventurer already noticed, an Irishman by birth, who, endowed with singular talents and intrepidity, had founded for himself an independent state in the north-west of India, was then at war with the province of Bikānir. Having reached its frontiers, the Bhattis solicited his alliance, and, to induce him to espouse their cause the more readily, offered him 40,000 rupees if he would reduce the obnoxious

fort. In the prosecution of the war several actions ensued, and various fortresses were taken; but it would appear that one of the Bhatti chiefs at variance with General Thomas commenced hostilities against him about the period now alluded to; and in this new warfare with his late allies his forces were so much reduced by repeated encounters, that, being scarcely able to stand an engagement, he fortified his camps. The Bhattis, after frequent attacks, withdrew their troops by night; whereupon General Thomas took and burned Fathiábád and other places, and might have occupied the whole country, had not a neighbouring chief concluded an alliance with the Bhattis, and sent 1000 cavalry to their aid. General Thomas retreated to Jajjar, a town within his own territory, leaving the Bhattis in possession of their capital.

The triumphs of the British arms proved fatal to the European adventurers who at that period had established themselves in Northern India, and the arrangements made with Sindia brought the British into contact with the country of the Bhattis, against whom they were compelled in 1810 to march a force, which expelled the chief, and transferred the greater part of the territory to his son, who had voluntarily proceeded to the British camp.

**BHÁWALPUR**, a feudatory state in North-Western India, under the political jurisdiction of the Lieutenant-Governor of the Panjáb, lying between 27° 41' and 30° 25' N. lat., and 69° 30' and 73° 58' E. long. It is bounded on the N. by Sind and Panjáb, on the E. and S.E. by the British district of Hissar and the Rájput states of Bikánir and Jasalmír, and on the S.W. by Sind. The state contains an estimated area of about 22,000 square miles; greatest length from N.E. to S.W., 310 miles; greatest breadth, 110 miles. Only a sixth part of the total area is capable of cultivation.

Thornton thus describes the general aspect of the state:—"Bhawalpur is a remarkably level country, there being no considerable eminence within its limits, as the occasional sand-hills, seldom exceeding 50 or 60 feet in height, cannot be considered exceptions. The cultivable part extends along the river line for a distance of about 10 miles in breadth from the left or eastern bank. In the sandy part of the desert beyond this strip of fertility both men and beasts, leaving the beaten path, sink as if in loose snow. Here, too, the sand is raised into ever-changing hills by the force of the wind sweeping over it. In those parts of the desert which have a hard level soil of clay, a few stunted mimosa, acacias, and other shrubs are produced, together with rue, various bitter and aromatic plants, and occasionally tufts of grass. Much of the soil of the desert appears to be alluvial; there are numerous traces of streams having formerly passed over it, and still, where irrigation is at all practicable, fertility in the clayey tract follows; but the rains are scanty, the wells few and generally 100 feet deep or more."

The Ghará, a great stream formed by the united waters of the Bis and Satej, the Indus, and the Panjnad, are the principal rivers of the state, affording a continuous river-line of 300 or 350 miles in length. In 1872 the population was estimated at 472,791, the majority of whom are Mahometans, consisting of Játs of Hindu descent, Beluchis, and Afghans. The principal products are woollen and cotton cloths, silk goods, indigo, cereals, alum, saltpetre, &c. These form the principal exports; the imports are inconsiderable. Value of external trade in 1872, £358,000; internal trade, £444,700. Principal trade routes:—(1), From Bikánir to Central Asia via Bhawalpur; (2), from Jasalmír to Afghánistán; (3), from Bhawalpur to Sind. In 1872 the gross revenue of the state was returned as £197,344; estimated military force, 2679. Principal towns—Bhawalpur, the capital, situated on a branch of the River Ghará; Ahmadpur, Uah, Khanpur, and Michinábd.

The state was a dependency of the Duráni kingdom till its dismemberment, when Bhawalpur became independent. On the rise of Ranjit Singh, the khán of Bhawalpur tendered his allegiance to the British Government, and received a life-pension of £10,000 per annum for his services in the Sikh war. The present ruler is a minor (1875), and the state is now under British management, under which it has greatly prospered. The Panjáb Administration Report for 1871-72 states that on the death

of the late chief, when Bhawalpur came under British management, "the treasury was empty, the Government in debt, the army disorganized, the canals, on which cultivation mainly depends, neglected, while a general sense of insecurity prevailed; but now (1871-72) there is a cash balance of £80,000 in hand, the state debts have been paid off, the revenue has reached £200,000 a year (or double what it was three years ago), while the ordinary expenditure is about £160,000, the canals have been greatly increased in number and efficiency, waste lands have been brought under cultivation, population has increased, and the army has been reorganized."

**BHIL**, a tribe and a British political agency in Central India. The political agency comprises the following native states:—(1.) Dhár, revenue in 1871-72, £60,000, expenditure £55,000; (2.) Bahktanagar, revenue £5933, expenditure £4495; (3.) Jabuá, revenue £11,000, expenditure the same; (4.) Alirájpur, revenue £12,095, expenditure £10,783; (5.) Matwaah, revenue £620, expenditure £334; (6.) Jobat, revenue £1500, expenditure £1200; (7.) Katiwára; (8.) Ratanmall; (9.) Amjherá, Dektán, Ságar, Báng, Bankánir, and Manáwan, belonging to Sindhiá; and (10.) Pitláwad and Chikáldá, belonging to Holkár. The Bhil agency comprises an area of 8160 square miles, with a population of 240,000 souls, and consists of—(1.) Mánpur Parganá (British); (2.) Barwáni state (under British management in 1871-72); (3.) Jamniá, Rájgaah, Garhi, and other Bhumia chiefdoms; (4.) Holkár's districts south of the Vindhyan range; and (5.) Dewas or Bágod Parganá. The Bhil agency was formed in 1825, when the Bhil corps was organized, with a view to utilizing the warlike instincts of the Bhil tribes. This brave body of men have done good service, and gradually put down the predatory habits of their countrymen. The Bhil tribes chiefly inhabit the rocky ranges of the Vindhya and Sápura mountains, and the banks of the Narbadá and the Tapti. In common with other hill tribes, the Bhils are supposed to have been aborigines of India, and to have been driven to their present fastnesses at the time of the Hindu invasion. They are of dark complexion and diminutive stature, but active, and capable of enduring great fatigue. Various efforts have been made by the British Government to reclaim this people from their predatory habits, and in 1869-70 the official report stated that "the Bhils of Mánpur are becoming reconciled to the life of cultivators, though not yet willing to take out leases."

**BHOPAL**, a British political agency in Central India, comprising 31 native administrations classified as follows:—First, Bhopál; a treaty state, its ruler having the power of life and death; second, Rájgarh and Narsinggarh, the rulers of which receive salutes, and exercise independent civil and criminal jurisdiction, but submit proceedings in cases of heinous crime for the political agent's review; third, Kilchipur, Kurwál, and Maksudnagar, the chiefs of which receive no salute, but possess independent authority, except in heinous offences; fourth, Pathári, Basaudá, and Muhammadgarh, lesser chiefships, under the more direct supervision of the political agent; Larawát, the chief of this is a *jagirdar* or holder of a grant of land under life tenure, and is subordinate to the political agent in all matters of administration; fifth, sixteen petty chiefs called *thákurs* and *jagirdars*; sixth, four districts of other native states not within the jurisdiction of this agency. The Bhopál political agency is subordinate to the Central India agency.

**BHOPAL**, a native state in Malwa in Central India, under the political superintendence of the British Government, lying between 22° 32' and 23° 46' N. lat., and 76° 25' and 78° 50' E. long. It is bounded on the N. by the state of Gwalior and the British district of Bairsá, on the N.E. and S.E. by the Ságar and Nee-

back territory, on the S.W. by the possessions of Holkar and Sindhiá, and on the N.W. by Sindhiá's districts and Omatwára. Length of the state from E. to W., 157 miles; breadth from N. to S., 76 miles; estimated area, 6764 square miles. The surface of the country is uneven, being traversed by the Vindhya ranges, a peak of which near Rayson is upwards of 2500 feet above sea-level. The general inclination of the country is towards the north, in which direction most of the streams of the state flow, while others, passing through the Vindhyan ranges, flow to the Narbadá. The population of the state is estimated at 663,656, comprising Hindus, Mahometans, and the Gonds, an aboriginal tribe. Principal crops: wheat, Indian corn, oil-seeds, pulses, opium. Chief routes: (1), from Sagar through the town of Bhopál to the British cantonment of Mhow; (2), from Bhisá to Hoshangábád and thence to Mhow; (3), from Hoshangábád to Nimach; (4), from Jabalpur through Hoshangábád to Mhow. Principal towns: Bhopál the capital, Islámnagar, Ashtá, Sihor, and Ráisen. In 1871-72 the annual income of the state is estimated at £240,000. Bhopál state was founded in 1723 by Dost Muhammad Khán, an Afghán adventurer. In 1818 a treaty of dependence was concluded between the chief and the British Government. Since then Bhopál has been steadily loyal to the British Government, and during the mutiny it rendered good services. The present ruler is a lady, and both she and her mother, who preceded her as head of the state, have displayed the highest capacity for administration. Both have been appointed Knights of the Star of India, and their territory is the best governed native state in India.

**BHUTAN**, an independent kingdom in the Eastern Himalayas, between 26° and 28° N. lat. and 89° and 93° E. long. It is bounded on the N. by Thibet; on the E. by a tract inhabited by various uncivilized independent mountain tribes; on the S. by the British province of Assam, and the district of Jalpaiguri; and on the W. by the independent native state of Sikkim. The whole of Bhután presents a succession of lofty and rugged mountains abounding in picturesque and sublime scenery. "The prospect," says Captain Turner, "between abrupt and lofty prominences is inconceivably grand; hills clothed to their very summits with trees, dark and deep glens, and the high tops of mountains lost in the clouds, constitute altogether a scene of extraordinary magnificence and sublimity." As might be expected from its physical structure, this alpine region sends out numerous rivers in a southerly direction, which, forcing their passage through narrow defiles, and precipitated in cataracts over the precipices, eventually pour themselves into the Brahmaputra. One torrent is mentioned by Turner as falling over so great a height that it is nearly dissipated in mid-air, and looks from below like a jet of steam from boiling water. Of the rivers traversing Bhután, the most considerable is the Maná, flowing in its progress to the Brahmaputra under the walls of Táságon, below which it is unfordable. At the foot of Táságon Hill it is crossed by a suspension bridge. The other principal rivers are the Máchu, Tchinchu, Torahá, Mánchi, and Dharlá.

Previous to the British annexation of the Dwáras from Bhután, the area of the kingdom was reckoned at 20,000 sq. miles. The population of the country now remaining to Bhután was estimated in 1864 at 20,000 souls. Later information, however, points to a larger figure. The people are industrious, and devote themselves to agriculture, but from the geological structure of the country, and from the insecurity of property, regular husbandry is limited to comparatively few spots. The people are oppressed and poor. "Nothing that a Bhutiá possesses is his own," wrote the British envoy in 1864; "he is at all

times liable to lose it if it attracts the cupidity of any one more powerful than himself. The lower classes, whether villagers or public servants, are little better than the slaves of higher officials. In regard to them no rights of property are observed, and they have at once to surrender anything that is demanded of them. There never was, I fancy, a country in which the doctrine of 'might is right' formed more completely the whole and sole law and custom of the land than it does in Bhután. No official receives a salary; he has certain districts made over to him, and he may get what he can out of them; a certain portion of his gains he is compelled to send to the Darbár; and the more he extorts and the more he sends to his superior, the longer his tenure of office is likely to be." Captain Pemberton thus describes their moral condition—"I sometimes saw a few persons in whom the demoralizing influences of such a state of society had yet left a trace of the image in which they were originally created, and where the feelings of nature still exercised their accustomed influence, but the exceptions were rare, and although I have travelled and resided amongst various savage tribes on our frontiers, I have never yet known a people so wholly degraded as the Bhutiás." Physically the Bhutiás are a fine race, although dirty in their habits and persons. Their food consists of meat, chiefly pork, turnips, rice, barley-meal, and tea made from the brick-tea of China. Their favourite drink is *chong*, distilled from rice or barley and millet, and *Marud*, beer made from fermented millet. A loose woollen coat reaching to the knees, and bound round the waist by a thick fold of cotton cloth, forms the dress of the men; the women's dress is a long cloak with loose sleeves. The houses of the Bhutiás are of three and four stories; all the floors are neatly boarded with deal; and on two sides of the house is a verandah ornamented with carved work generally painted. The Bhutiás are neat joiners, and their doors, windows, and panelling are perfect in their way. No iron-work is used; the doors open on ingenious wooden hinges. The appearance of the houses is precisely that of Swiss chalets, picturesque and comfortable—the only drawback being a want of chimneys, which the Bhutiás do not know how to construct. The people nominally profess the Buddhist religion, but in reality, their religious exercises are confined to the propitiation of evil spirits, and the mechanical recital of a few sacred sentences. Around the cottages in the mountains the land is cleared for cultivation, and produces thriving crops of barley, wheat, buckwheat, millet, mustard, chillies, &c. Turnips of excellent quality are extensively grown; they are free from fibre and remarkably sweet. The wheat and barley have a full round grain, and the climate is well adapted to the production of both European and Asiatic vegetables. Potatoes have been introduced. The Bhutiás lay out their fields in a series of terraces cut out of the sides of the hills; each terrace is rivetted and supported by stone embankments, sometimes twenty feet high. Every field is carefully fenced with pine branches, or protected by a stone wall. A complete system of irrigation permeates the whole cultivated part of a village, the water being often brought from a long distance by stone aqueducts. Bhutiás do not care to extend their cultivation, as an increased revenue is exacted in proportion to the land cultivated, but devote their whole energies to make the land yield twice what it is estimated to produce. The forests of Bhután abound in many varieties of stately trees. Among them are the beech, ash, birch, maple, cypress, and yew. Firs and pines cover the mountain heights; and below these, but still at an elevation of eight or nine thousand feet, is a zone of vegetation, consisting principally of oaks and rhododendrons. The cinnamon tree is also found. Some

of the roots and branches were examined by Turner during his journey to Thibet; but the plant being neither in blossom nor bearing fruit, it was impossible to decide whether it was the true cinnamon or an inferior kind of cassia. The leaf, however, corresponded with the description given of the true cinnamon by Linnæus. The lower ranges of the hills abound in animal life. Elephants are so numerous as to be dangerous to travellers; but tigers are not common, except near the River Tistá. Leopards abound in the Hah valley; deer everywhere, some of them of a very large species. The musk deer is found in the snows, and the barking deer on every hill side. Wild hogs are met with even at great elevations. Large squirrels are common. Bears and rhinoceros are also found. Pheasants, jungle fowls, pigeons, and other small game abound. The Bhutiás are no sportsmen. They have a superstitious objection to firing a gun, thinking that it offends the deities of the woods and valleys, and brings down rain. A species of horse, which seems indigenous to Bhután, and is used as a domestic animal, is called *tángan*, from *Tángastán*, the general appellation of that assemblage of mountains which constitutes the territory of Bhután. It is peculiar to this tract, not being found in any of the neighbouring countries of Assam, Népál, Thibet, or Bengal, and unites in an eminent degree the two qualities of strength and beauty. The *tángan* horse usually stands about thirteen hands high, is short bodied, clean-limbed, deep in the chest, and extremely active, his colour usually inclining to piebald. In so barren and rude a country the manufacturing industry of its people is, as might be expected, in a low stage, the few articles produced being all destined for home consumption. These consist of coarse blankets and cotton cloths made by the villagers inhabiting the southern tract. Leather, from the hide of the buffalo, imperfectly tanned, furnishes the soles of snow boots. Circular bowls are neatly turned from various woods. A small quantity of paper is made from a plant described as the *Daphne papyrifera*. Swords, iron spears, and arrow-heads, and a few copper caldrons fabricated from the metal obtained in the country, complete the list of manufactures. The foreign trade of Bhután has greatly declined. In 1809 the trade between Assam and Bhután amounted to £20,000 per annum, the lac, madder, silk, *serendí* cloth, and dried fish of Assam, being exchanged for the woollens, gold-dust, salt, musk, horses, and silk of Bhután. At present very little trade is carried on by Bhután with the neighbouring countries. The military resources of the country are on an insignificant scale. Beyond the guards for the defence of the various castles, there is nothing like a standing army. The total military force was estimated by the British envoy in 1864 at 6000. The climate of Bhután varies according to the difference of elevation. At the time when the inhabitants of Punákhá (the winter residence of the Rájás) are afraid of exposing themselves to the blazing sun, those of Ghásá experience all the rigour of winter, and are chilled by perpetual snows. Yet these places are within sight of each other. The rains descend in floods upon the heights; but in the vicinity of Tásí-sudon, the capital, they are moderate; there are frequent showers, but nothing that can be compared to the tropical rains of Bengal. Owing to the great elevation and steepness of the mountains, dreadful storms arise among the hollows, often attended with fatal results.

*History.*—Bhután formerly belonged to a tribe called by the Bhutiás Tephu, generally believed to have been the people of Kuch Behar. About two hundred years ago some Thibetan soldiers subjugated the Tephus, took possession of the country, and settled down in it. At the head of the Bhután government there are nominally two supreme authorities, the Dharm Rájá, the spiritual head,

and the Deb Rájá, the temporal ruler. To aid these Rájás in administering the country, there is a council of permanent ministers, called the Lenehen. Practically, however, there is no government all. Subordinate officers and rapacious governors of forts wield all the power of the state, and tyranny, oppression, and anarchy reign over the whole country. The Dharm Rájá succeeds as an incarnation of the deity. On the death of a Dharm Rájá a year or two elapses, and the new incarnation then reappears in the shape of a child who generally happens to be born in the family of a principal officer. The child establishes his identity by recognizing the cooking utensils, &c., of the late Dharm Rájá; he is then trained in a monastery, and on attaining his majority is recognized as Rájá, though he exercises no more real authority in his majority than he did in his infancy. The Deb Rájá is in theory elected by the council. In practice he is merely the nominee of whichever of the two governors of East and West Bhután happens for the time to be the more powerful. The relations of the British with Bhután commenced in 1772, when the Bhutiás invaded the principality of Kuch Behar, a dependency of Bengal. The Kuch Behar Rájá applied for aid, and a force under Captain James was despatched to his assistance; the invaders were expelled and pursued into their own territories. Upon the intercession of Teahu Lama, then regent of Thibet, a treaty of peace was concluded in 1774 between the East India Company and the ruler of Bhután. In 1783 Captain Turner was deputed to Bhután, with a view of promoting commercial intercourse, but his mission proved unsuccessful. From this period little intercourse took place with Bhután, until the occupation of Assam by the British in 1826. It was then discovered that the Bhutiás had usurped several tracts of low land lying at the foot of the mountains, called the Dwáras or passes, and for these they agreed to pay a small tribute. They failed to do so, however, and availed themselves of the command of the passes to commit depredations within the British territory. Captain Pemberton was accordingly deputed to Bhután to adjust the points of difference. But his negotiations yielded no definite result; and every other means of obtaining redress and security proving unsuccessful, the Assam Dwáras were wrested from the Bhutiás, and the British Government consented to pay to Bhután a sum of £1000 per annum as compensation for the resumption of their tenure, during the good behaviour of the Bhutiás. Continued outrages and aggressions were, however, committed by the Bhutiás on British subjects in the Dwára. Notwithstanding repeated remonstrances and threats, scarcely a year passed without the occurrence of several raids in British territory headed by Bhutiá officials, in which they plundered the inhabitants, massacred them, or carried them away as slaves. In 1863 Mr Ashley Eden was sent as an envoy to Bhután to demand reparation for these outrages. He did not succeed in his mission; he was subjected to the grossest insults; and under compulsion signed a treaty giving over the disputed territory to Bhután, and making other concessions which the Bhután Government demanded. On Mr Eden's return the viceroy at once disavowed his treaty, sternly stopped the former allowance for the Assam Dwáras, and demanded the immediate restoration of all British subjects kidnapped during the last five years. The Bhutiás not complying with this demand, the Governor-General issued a proclamation, dated the 12th November 1864, by which the eleven Western or Bengal Dwáras were forthwith incorporated with the Queen's Indian dominions. No resistance was at first offered to the annexation; but, suddenly, in January 1865, the Bhutiás surprised the English garrison at Diwángiri, and the post was abandoned with



the loss of two mountain train guns. This disaster was soon retrieved by General Tombs, and the Bhutias were compelled to sue for peace, which was concluded on the 11th November 1865. The Bhutian Government formally ceded all the eighteen Dwars of Bengal and Assam, with the rest of the territory taken from them, and agreed to liberate all kidnapped British subjects. As the revenues of Bhutian mainly depended on these Dwars, the British Government, in return for these concessions, undertook to pay the Deb and Dharm Rajas annually, subject to the condition of their continued good behaviour, an allowance beginning at £2500 and rising gradually to a maximum of twice that amount. Since that time nothing of importance has occurred, and the annexed territories have settled down into peaceful and prosperous British districts.

**BIAFRA**, a tract of country on the coast of Western Africa, on a bay or bight of the same name. Lander, in descending the Niger, arrived in the Bight of Biafra, and thus left no doubt that the system of inter-ramified river-channels, extending from Benin to Biafra, constitutes the delta of that river. The Bight of Biafra, or Mafra, is the most eastern part of the Gulf of Guinea, between Capes Formosa and Lopes; it contains the islands of Fernando Po, Princes, and St Thomas's.

**BIANCHINI, FRANCIS**, a learned Italian astronomer and antiquary, was born at Verona in 1662, of a noble and ancient family. He was educated at Padua, and devoted himself especially to mathematics and classics. In 1684 he went to Rome, and was made librarian to Cardinal Ottoboni, afterwards Pope Alexander VIII. He was made canon of Sta Maria de la Rotonda, and afterwards of St Lorenzo in Damaso. His first work seems to have been a treatise directed against the Copernican system; it was published about 1680. In 1697 appeared the first and only volume of his *Universal History*, coming down to the close of the Assyrian empire. His later works, with the exception of the *Hesperii et Phosphori nova Phænomena*, a series of observations on Venus, were chiefly upon the ruins excavated on the Via Appia and Mount Palatine. He died in 1729.

**BIARRITZ**, a watering-place in the south of France, in the department of Basses-Pyrénées, on the sea-coast about five miles south-west of Bayonne. From a mere fishing village, with a few hundred inhabitants, in the beginning of the century, it rose rapidly into a place of importance under the patronage of the late emperor Napoleon III. and the empress, with whom it was a favourite resort. Excellent bathing-ground is afforded by the Vieux Port and the various sheltered bays into which the cliffs of this part of the coast are carved by the swell of the Atlantic; and the irregular eminences and promontories supply attractive sites for the erection of villas. The climate is delightful and bracing; and the bareness of the neighbourhood has been considerably relieved by fir plantations. Except the ruins of the castle of Atalaye, the lighthouse of Port Hart, the Villa Eugénie, erected for the empress in 1855-1856, the new French church, the English Protestant church, and the casino, there is no building with special claim to notice; the bathing establishments, cafés, and hotels are matters of course, but these are at least not unworthy the fame of the town. Since 1863, when it was decided that the construction of a new port was a matter of public utility, large sums of money have been expended in the attempt to form a satisfactory breakwater, but the severity of the winter storms has frequently interrupted the work. The permanent population of Biarritz, according to the census of 1871, was 3164; and the autumn visitors are estimated at from 12,000 to 15,000.

See Russell, *Biarritz and the Basque Countries*, 1873.

**BIAS**, a native of Priene, one of the seven sages of

Greece, was the son of Teutamius, and flourished about the middle of the 6th century B.C. He was one of the most eloquent speakers of his time, and is celebrated as having never used his talents for purposes of mere gain, but as having devoted them to the service of the injured and oppressed. Many stories are told illustrative of the nobility of his character in this and other respects. According to one of these, when his native town was taken by an enemy, and the inhabitants were carrying off whatever seemed to each most valuable, one of them, observing Bias without any burden, advised him to follow his example. "I am doing so," said he, "for I carry all my valuables with me." His fellow-citizens honoured him with a splendid funeral, and dedicated to him a sanctuary which they called Teutamium. He is said to have written an heroic poem on the affairs of the Ionians, in order to show them how they might be most prosperous. A great number of the short, pithy, ethical sayings or apophthegms characteristic of the Greek sages are ascribed to Bias. Of these a few specimens may be given—"Be slow to enter on an undertaking, but when you have begun, persevere to the end;" "Know, and then act;" "Hear much, speak little;" "Do not praise an unworthy man on account of his wealth;" "Take (i.e., gain your end) by persuasion, not by force;" "He is unfortunate who cannot bear misfortune;" "So order your affairs as if your life were to be both long and short." Bias is the author of the famous and often imitated reproof to the impious sailors, who in the midst of a tempest were calling on the gods—"Be quiet," said he, "lest the gods discover that you are here." (*Diog. Laert.*, i. 82-88; *Stobæus, Floril.*; *Mullach, Flug. Pk. Græc.*, i. 203, *egg.*)

**BIBERACH**, a town of Württemberg, in the circle of the Danube, a capital of a bailiwick 23 miles S.E.W. of Ulm. It is situated on the River Ries, a small tributary of the Danube, partly on level ground and partly on hills, and still has a somewhat mediæval appearance from the remains of its ancient walls and towers. Its principal church dates from the 12th century, and it possesses a hospital with very extensive endowments. The main objects of its varied industry are toys, cloth goods of different kinds, lace, paper, and leather; and there are also bell-foundries and breweries. In the neighbourhood is the watering-place called Jordansbad. Biberach appears as a village in the 8th century, and in the 15th it became a free imperial city. During the Thirty Years' War it underwent various vicissitudes, and was for a good while held by the Swedes. In 1707 it was captured and put to ransom by the French, who afterwards, in 1796 and 1800, defeated the Austrians in the neighbourhood. In 1803 the city was deprived of its imperial freedom and assigned to Baden; and in 1806 it was transferred to Württemberg. Biberach is the birthplace of the sculptor Natter and the painter Neher; and Wieland, who was born at the neighbouring village of Oberholzhelm, spent a series of years in the town.

**BIBIRINE**, or **BEBERINE**, an alkaloid obtained from the bark and fruit of the greenheart tree, *Nectandra Rodia*, called bibiru or sipiri in Guiana, where the tree grows. The alkaloid was discovered about the year 1835 by Hugh Rodie, a surgeon resident in Demerara, who found it possessed great efficacy as a febrifuge, and it was recommended by him as a substitute for quinine. The sulphate of bibirine has a place in the British pharmacopœia, and is in considerable use in medicine as a bitter tonic and febrifuge. Bibirine has been shown by Wals to be apparently identical with an alkaloid obtained from the common box, *Buxus sempervirens*, called buxine, and this opinion is to some extent confirmed by Dr Fliëcker. The sulphate of bibirine found in commerce is a dark brown substance in thin translucent scales.

## B I B L E

**T**HE word **BIBLE**, which in English, as in Mediaeval Latin, is treated as a singular noun, is in its original Greek form a plural,—τὰ βιβλία, *the (sacred) books*,—correctly expressing the fact that the sacred writings of Christendom are made up of a number of independent records, which set before us the gradual development of the religion of revelation. The origin of each of these records forms a distinct critical problem; and for the discussion of these questions of detail the reader is referred to the articles on separate Biblical books. The present article seeks to give a general account of the historical and literary conditions under which the unique literature of the Old and New Testaments sprang up, and of the way in which the Biblical books were brought together in a canonical collection and handed down from age to age. The Biblical development is divided into two great periods by the manifestation and historical work of Christ. In its pre-Christian stage the religion of revelation is represented as a *covenant* between the spiritual God and His chosen people the Hebrews. In accordance with this and in allusion to Jer. xxxi. 31, Jesus speaks of the new dispensation founded in His death as a new *covenant* (1 Cor. xi. 25). Hence, as early as the 2d century of our era the two great divisions of the Bible were known as the books of the Old and of the New Covenant respectively. Among Latin-speaking Christians the Greek word for covenant was often incorrectly rendered *testament*, and thus Western Christendom still uses the names of the Old and New Testaments.

**OLD TESTAMENT.**—*Struggle and Progress of Spiritual Religion. Priests, Prophets, &c.*—The pre-Christian age of the Biblical religion falls into a period of religious productivity and a subsequent period of stagnation and mainly conservative traditions. The period of productivity is also a period of contest, during which the spiritual principles of the religion of revelation were involved in continual struggle with polytheistic nature-worship on the one hand, and, on the other hand, with an unspiritual conception of Jehovah as a God whose interest in Israel and care for His sanctuary were independent of moral conditions. In this long struggle, which began with the foundation of the theocracy in the work of Moses, and did not issue in conclusive victory until the time of Ezra, the spiritual faith was compelled to show constant powers of new development,—working out into ever clearer form the latent contrasts between true and false religion, proving itself fitter than any other belief to supply all the religious needs of the people, and, above all, finding its evidence in the long providential history in which, from the great deliverance of the Exodus down to the Captivity and the Restoration, the reality of Jehovah's kingship over Israel, of His redeeming love, and of His moral government, were vindicated by the most indisputable proofs. As it was only the deliverance from Egypt and the theocratic covenant of Sinai that bound the Hebrew tribes into national unity, the worship of Jehovah was always acknowledged as the national religion of Israel. But from Joshua to Samuel national feeling was far weaker than tribal jealousy; and in the political disintegration of the people the religion of Jehovah seemed ready to be lost in local superstitions. During this period the chief centre of monotheism was the sanctuary and priesthood of the ark; and it was from the priestly circle that Samuel arose to reunite the nation by recalling it to the religion of Jehovah, and thus to prepare the way for the splendid age of David and Solomon. But though Samuel was by education a priest, it was not as a priest, but as a prophet that he accomplished this work.

In all ages a priesthood is conservative, not creative; and it was only as a growing and creative power that the still undeveloped spiritual religion could live. While it was the business of the priest faithfully to preserve religious traditions already acknowledged as true and venerable, the characteristic of the prophet is a faculty of spiritual intuition, not gained by human reason, but coming to him as a word from God himself, wherein he apprehends religious truth in a new light, as bearing in a way not manifest to other men on the practical necessities, the burning questions of the present. Unlike the priesthood, the prophets never formed a regular guild. It was an axiom that the gift of prophecy was bestowed by the inward and immediate call of Jehovah. But from the time of Samuel we find a regular succession of prophets working out the spiritual problems of the national faith with ever increasing clearness, and gathering round them, sometimes in regularly formed communities, a circle of disciples and sympathisers which, though never, perhaps, numerically considerable, embraced the names of David and other leaders of Hebrew history, and impressed the stamp of prophetic influence on every part of the national life. From this time the priests held only the second place in the history of the Old Testament religion; sometimes they even appear as the opponents of the prophetic party, whose progressive ideas are distasteful to their natural conservatism and aristocratic instincts. But on the whole, the more enlightened ministers of the central sanctuary continued to share with the prophets the task of upholding a lofty religious tradition, and not unfrequently both characters were united in one person. It was, in fact, only through the priests that the ideas of the prophets could receive public sanction in the ordinances of religion, as it was only through rulers like David, or Hezekiah, or Jehu, that they could influence the political conduct of affairs.

A just insight into the work of the prophetic party in Israel was long rendered difficult by traditional prejudices. On the one hand the predictive element in prophecy received undue prominence, and withdrew attention from the influence of the prophets on the religious life of their own time; while, on the other hand, it was assumed, in accordance with Jewish notions, that all the ordinances, and almost, if not quite, all the doctrines of the Jewish church in the post-canonical period, existed from the earliest days of the theocracy. The prophets, therefore, were conceived partly as inspired preachers of old truths, partly as predicting future events, but not as leaders of a great development, in which the religious ordinances as well as the religious beliefs of the Old Covenant advanced from a relatively crude and imperfect to a relatively mature and adequate form.

The proof that this latter view, and not the traditional conception, is alone true to history depends on a variety of arguments which cannot here be reproduced. That the religious ideas of the Old Testament were in a state of growth during the whole prophetic period became manifest as soon as the laws of grammatico-historical exegesis were fairly applied to the Hebrew Scriptures. That the sacred ordinances were subject to variation was less readily admitted, because the admission involved a change of view as to the authorship of the Pentateuch; but here also the facts are decisive. For example, the law in Exod. xx. 24, *f.*, contemplates the worship of Jehovah on other altars than that of the central sanctuary (*cf.* Deut. xxxiii. 19). This practice, accordingly, was followed by Samuel, and was fully approved by Elijah (1 Kings xix. 14). But the worship

of Jehovah on the high places or local sanctuaries was constantly exposed to superstitious corruption and heathen admixture, and so is frequently attacked by the prophets of the 8th century. It was undoubtedly under their influence that Hezekiah abolished the high places. The abolition was not permanent; but in the reign of Josiah, the next reforming king, we find that the principle of a single sanctuary can claim the support not only of prophetic teaching, but of a written law-book found in the temple, and acknowledged by the high priest (2 Kings xxii., xxiii.) The legislation of this book corresponds not with the old law in Exodus, but with the book of Deuteronomy. But perhaps the clearest proof that, during the period of prophetic inspiration, there was no doctrine of finality with regard to the ritual law any more than with regard to religious ideas and doctrines, lies in the last chapters of Ezekiel, which sketch at the very era of the Captivity an outline of sacred ordinances for the future restoration. From these and similar facts it follows indisputably, that the true and spiritual religion which the prophets and like-minded priests maintained at once against heathenism and against unspiritual worship of Jehovah as a mere national deity without moral attributes, was not a finished but a growing system, not finally embodied in authoritative documents, but propagated mainly by direct personal efforts. At the same time these personal efforts were accompanied and supported by the gradual rise of a sacred literature. Though the priestly ordinances were mainly published by oral decisions of the priests, which are, in fact, what is usually meant by the word *law* (Torah) in writings earlier than the Captivity, there can be no reasonable doubt that the priests possessed written legal collections of greater or less extent from the time of Moses downwards. Again, the example of Ezekiel, and the obvious fact that the law-book found at the time of Josiah contained provisions which were not up to that time an acknowledged part of the law of the land, makes it probable that legal provisions, which the prophets and their priestly allies felt to be necessary for the maintenance of the truth, were often embodied in legislative programmes, by which previous legal tradition was gradually modified. Then the prophets, especially when they failed to produce immediate reformation, began from the 8th century, if not still earlier, to commit their oracles to writing; and these written prophecies—circulating widely in a nation which had attained a high degree of literary culture, and frequently cited by later seers—disseminated prophetic teaching in a permanent form. Long before this time music and song had been practised in the prophetic circle of Samuel, and were introduced under David into the service of the sanctuary. Another important vehicle of religious instruction was the written history of the nation, which could not fail to be generally set forth in the theocratic spirit in which all loftier Hebrew patriotism had its root. And, indeed, the literary diffusion of spiritual ideas was not confined to the direct efforts of priests and prophets. In spite of the crass and unspiritual character of the mass of the people, the noblest traditions of national life were entwined with religious convictions, and the way in which a prophet, like Amos, could arise untrained from among the herdsmen of the wilderness of Judah, shows how deep and pure a current of spiritual faith flowed among the more thoughtful of the laity. Prophecy itself may from one point of view be regarded simply as the brightest efflorescence of the lay element in the religion of Israel, the same element which in subjective form underlies many of the Psalms, and in a shape less highly developed tinged the whole proverbial and popular literature of the nation; for in the Hebrew commonwealth popular literature had not yet sunk to represent the lowest impulses of national life.

*Close of the Old Testament Development. Formation of the Canon.*—The struggle between spiritual and unspiritual religion was brought to a crisis when the prophetic predictions of judgment on national sin were fulfilled in the fall of the kingdom of Judah. The merely political worship of Jehovah as the tutelary god of the state was now reduced to absurdity. Faith in the covenant God was impossible except on the principles of spiritual belief. Nor did the restoration by Cyrus affect this result. No political future lay before the returning exiles, and continued confidence in the destiny of the race was not separable from the religious ideas and Messianic hopes of the prophets. To obey the law of Jehovah and patiently to await the coming Deliverer was the only distinctive vocation of the community that gathered in the new Jerusalem; and after a period of misfortune and failure, in which the whole nation seemed ready to collapse in despair, this vocation was clearly recognized and embodied in permanent institutions in the reformation of Ezra and Nehemiah (445 B.C.) But with this victory the spiritual religion passed into a stationary state. The spirit of prophecy, long decadent, expired with Malachi, the younger contemporary of Nehemiah; and the whole concern of the nation from this time downwards was simply to preserve the sacred inheritance of the past. The Exile had so utterly broken all continuity of national life, that that inheritance could only be sought in the surviving monuments of sacred literature. To these, more than to the expiring voice of prophecy in their midst, the founders of the new theocracy turned for guidance. The books that had upheld the exiles' faith, when all outward ordinances of religion were lacking, were also the fittest teachers of the restored community. Previous reformers had been statesmen or prophets. Ezra is a scribe who comes to Jerusalem armed, not with a fresh message from the Lord, but with "the book of the law of Moses." This law-book was the Pentateuch, and the public recognition of it as the rule of the theocracy was the declaration that the religious ordinances of Israel had ceased to admit of development, and the first step towards the substitution of a *canon* or authoritative collection of Scriptures for the living guidance of the prophetic voice. A second step in the same direction is ascribed to Nehemiah by a tradition intrinsically probable, though of no great external authority. He, it is said, collected a library which, besides documents of temporary importance, embraced "the books about the kings and prophets, and the writings of David" (2 Mac. ii. 13.) Certainly a complete body of the remains of the prophets, with an authentic account of the history of the period of their activity, must soon have been felt to be scarcely second in importance to the law; and so Nehemiah may very well be supposed to have begun the collection which now forms the second part of the Hebrew Bible, embracing, under the general title of *The Prophets*, the historical books of Joshua, Judges, Samuel, Kings (*Earlier Prophets*), and the four prophetic books of Isaiah, Jeremiah, Ezekiel, and the twelve minor prophets (*Later Prophets*). The mention of the writings of David implies that Nehemiah also began the formation of the third and last part of the Hebrew canon, which comprises, under the title of *Ketubim* (Scriptures, Hagiographa), the Psalms, Proverbs, Job, the five Megillot or *rolls* (Canticles, Ruth, Lamentations, Ecclesiastes, Esther), and, finally, Daniel, Ezra, Nehemiah, and Chronicles. It is certain, however, that this part of the collection was not completed till long after Nehemiah's time; for to say nothing of the disputed dates of Ecclesiastes and Daniel, the book of Chronicles contains genealogies which go down at least to the close of the Persian period. The miscellaneous character of the Ketubim seems, in fact, to show that after the Law and the Prophets were

closed, the third part of the canon was open to receive additions, recommended either by their religious and historical value, or by bearing an ancient and venerable name. And this was the more natural because the Hagiographa had not the same place in the synagogue service as was accorded to the Law and the Prophets.

The time and manner in which the collection was absolutely closed is obscure. The threefold division of the sacred writings is referred to in the prologue to the Wisdom of Sirach (Ecclesiasticus) about 130 a.c., but Jewish tradition indicates that the full canonicity of several books, especially of Ecclesiastes, was not free from doubt till the time of the famous R. Akiba, who perished in the great national struggle of the Jews with the Emperor Hadrian (Mishna, *Jadaim*, 3; *Edaiot*, 5). The oldest list of canonical books, given by Josephus (c. *Aptom.*, i. 8), is of somewhat earlier date. Josephus seems to have had quite our present canon; but he took Ruth along with Judges, and viewed Lamentations as part of the book of Jeremiah, thus counting twenty-two books instead of the twenty-four of the Talmudic enumeration and of the present Hebrew Bible. There is other evidence that only twenty-two books were reckoned by the Jews of the first Christian century; and it appears that this number was accommodated to that of the letters of the Hebrew alphabet. Even in the time of Jerome, Ruth and Lamentations were not uniformly reckoned apart. The expansion of the Talmudic twenty-four to the thirty-nine Old Testament books of the English version is effected by reckoning the minor prophets one by one, by separating Ezra from Nehemiah, and by subdividing the long books of Samuel, Kings, and Chronicles. In this reckoning, and in the very different order of the books, we follow in the main the Alexandrian Greek and Vulgate Latin versions. But the Alexandrian differed from the Hebrew canon in more important points. The line of distinction between inspired and human writings was not so sharply drawn; and the Greek Bible not only admitted additions to several of the Hagiographa, but contained other apocryphal books, of some of which Greek was the original tongue, while others were translations of Hebrew or Aramaic writings. See *ΑΠΟΚΡΥΦΑ*.

In turning now to a literary and critical survey of the Old Testament books, we shall find it convenient to depart from the division of the Hebrew canon, in favour of a classification suggested by the order of the books followed in the English version and in most other translations. The Old Testament literature is made up of historical, poetico-didactic, and prophetic writings, and under these three heads we will arrange what remains to be said on the subject.

*Historical Books.*—These form two parallel series of sacred history. The books from Genesis to Kings give a continuous story (with some episodic additions) from the creation to the fall of the kingdom of Judah. The book of Chronicles covers the same ground on a narrower plan, contracting the early history into genealogical lists, and occupying itself almost entirely with the kingdom of Judah, and especially with matters connected with the temple and its worship. The narrative of the chronicler is continued in the books or rather book of Ezra and Nehemiah, which incorporates original memoirs of these two reformers, but otherwise is so exactly in the style of the Chronicles that critics are practically agreed in ascribing the whole to a single author, probably a Levite, who, as we have already seen, cannot have written before the close of the Persian empire. The questions that are raised as to the work of the chronicler belong less to the general history of Biblical literature than to special introduction. We pass on, therefore, to the larger and more important series. The Pentateuch and the so-called earlier prophets form together a

single continuous narrative. It is plain, however, that the whole work is not the uniform production of one pen, but that in some way a variety of records of different ages and styles have been combined to form a single narrative. Accordingly Jewish tradition bears that Moses wrote the Pentateuch, Joshua the book named after him, Samuel the book of Judges, and so forth. As all Hebrew history is anonymous,—a sure proof that people had not yet learned to lay weight on questions of authorship,—it is not probable that this tradition rests on any surer ground than conjecture; and, of course, a scribe who saw in the sacred books the whole outcome of Israel's history would naturally leap to the conclusion that the father of the Law was the author of the Pentateuch, and that the other leaders of Israel's history could not but be the writers of a great part of the Scriptures. A more careful view of the books themselves shows that the actual state of the case is not so simple. In the first place, the limits of the individual books are certainly not the limits of authorship. The Pentateuch as a law-book is complete without Joshua, but as a history it is so planned that the latter book is its necessary complement. (*Cf.*, for example, Exod. xvi. 35, Josh. v. 12; Gen. i. 24, 25; Exod. xiii. 19; Josh. xxiv. 33.) In truth, an author who wrote after the occupation of Canaan could never have designed a history which should relate all God's promises to Israel and say nothing of their fulfilment. But in its present shape the Pentateuch is certainly subsequent to the occupation, for it uses geographical names which arose after that time (Hebron, Dan, refers to the conquest as already accomplished (Deut. ii. 12, *cf.* Num. xv. 32; Gen. xii. 6), and even presupposes the existence of a kingdom in Israel (Gen. xxxvi. 31). And with this it agrees, that though there are marked differences of style and language within the book of Joshua, each style finds its counterpart in some section of the Pentateuch. In the subsequent books we find quite similar phenomena. The last chapters of Judges cannot be separated from the book of Samuel, and the earlier chapters of Kings are obviously one with the foregoing narrative; while all three books contain passages strikingly akin to parts of the Pentateuch and Joshua (*cf.*, for example, the book of Deuteronomy with Josh. xxiii., 1 Sam. xii., 1 Kings viii.) Such phenomena not only prove the futility of any attempt to base a theory of authorship on the present division into books, but suggest that the history as we have it is not one narrative carried on from age to age by successive additions, but a fusion of several narratives which partly covered the same ground and were combined into unity by an editor. This view is supported by the fact, that even as it now stands the history sometimes gives more than one account of the same event, and that the Pentateuch often gives several laws on the same subject. Of the latter we have already had one example, but for our present argument the main point is not diversity of enactment, which may often be only apparent, but the existence within the Pentateuch of distinct groups of laws partly taking up the same topics. Thus the legislation of Exod. xx.—xxiii. is partly repeated in ch. xxiv., and on the passover and feast of unleavened bread we have at least six laws, which if not really discordant, are at least so divergent in form and conception that they cannot be all from the same pen. (Exod. xii. 1–28, xiii. 3–10, xxiii. 15, xxxiv. 18; Lev. xxiii. 5–14, Deut. xvi.) Of historical duplicates the most celebrated are the twofold history of the creation and the flood, to which we must recur presently. The same kind of thing is found in the later books; for example, in the account of the way in which Saul became king, where it is scarcely possible to avoid the conclusion that 1 Sam. xi. 1–11 should attach directly to ch. x. 16 (*cf.* x. 7). But the extent to which the historical books are

made up of parallel narratives which, though they cover the same period, do not necessarily record the same events, was first clearly seen after Astruc (1753 A.D.) observed that the respective uses of Jehovah (Lord) and Elohim (God) as the name of the Deity afford a criterion by which two documents can be dissected out of the book of Genesis. That the way in which the two names are used can only be due to difference of authorship is now generally admitted, for the alternation corresponds with such important duplicates as the two accounts of creation, and is regularly accompanied through a great part of the book by unmistakable peculiarities of language and thought, so that it is still possible to reconstruct at least the Elohim document with a completeness which makes its original independence and homogeneity matter of direct observation. The character of this narrative is annalistic, and where other material fails blanks are supplied by genealogical lists. Great weight is laid on orderly development, and the name Jehovah is avoided in the history of the patriarchs in order to give proper contrast to the Mosaic period (*cf.* Gen. xvii. 1; Exod. vi. 3); and, accordingly, we find that the unmistakable secondary marks of this author run through the whole Pentateuch and Joshua, though the exclusive use of Elohim ceases at Exod. vi. Of course the disappearance of this criterion makes it less easy to carry out an exact reconstruction of the later parts of the document; but on many points there can be no uncertainty, and it is clearly made out that the author has strong priestly tendencies, and devotes a very large proportion of his space to liturgical matters. The separation of this document may justly be called the point of departure of positive criticism of the sources of the Old Testament; and present controversy turns mainly on its relation to other parts of the Pentateuch. Of these the most important are—1. The Jehovistic narrative, which also begins with the creation, and treats the early history more in the spirit of prophetic theology and idealism, containing, for example, the narrative of the fall, and the parts of the history of Abraham which are most important for Old Testament theology. That this narrative is not a mere supplement to the other, but an independent whole, appears most plainly in the story of the flood, where two distinct accounts have certainly been interwoven by a third hand. 2. Many of the finest stories in Genesis, especially great part of the history of Joseph, agree with the Elohim-document in the name of God, but are widely divergent in other respects. Since the researches of Hupfeld, a third author, belonging to northern Israel, and specially interested in the ancestors of the northern tribes, is generally postulated for these sections. His literary individuality is in truth sharply marked, though the limits of his contributions to the Pentateuch are obscure.

It will be remembered that we have already seen that three currents of influence run through the Old Testament development,—the traditional lore of the priests, the teaching of the prophets, and the religious life of the more enlightened of the people. Now, in the three main sections of the early history just enumerated we find the counterpart of each of these. The priestly narrative of the Elohist, the prophetic delineation of the Jehovist, the more picturesque and popular story of the third author, embody three tendencies, which are not merely personal but national, and which constantly reappear in other parts of Hebrew literature. Up to the book of Joshua all three run side by side. But the priestly interest found little scope in the subsequent history; and from the time of the Judges we can generally distinguish only sections marked by prophetic pragmatism and others which, though distinctly religious and even theocratic, are, so to speak, written from a layman's stand-point. The latter comprise a large part

of Judges, and by far the greatest part of Samuel, as well as the beginning of Kings. To the modern mind this part of the narrative, which is rich in colour and detail, is by far the most interesting, and it is with sincere regret that we pass at 1 Kings xi. to a division of the history for which the chief sources—cited as the Chronicles of the Kings of Israel and Judah respectively—treat almost exclusively of the outer political life of the nation. In striking contrast to the uniformity of this narrative are the interspersed histories of Elijah and other northern prophets. These histories are very remarkable in style and even in language; and, containing some of the noblest passages of the Old Testament, form one of many proofs of the unusual literary genius of the kingdom of Ephraim. But how are these various narratives related to each other? This question is not easy to answer. In general the third or lay element of the history seems to stand nearest to the events recorded, and even, perhaps, to form the direct basis of the prophetic matter; while, occasionally, old lists of names and places, poetico-historical pieces, and the like, form a still deeper stratum in the story. (Poetical pieces in the *Book of the Wars of Jehovah*, Num. xxi. 14; *Book of Jashar* [the upright], Josh. x. 13; 2 Sam. i. Lists like 2 Sam. xxiii.) Whether the same hands or only the same tendencies as appear in the non-Levitical parts of Genesis run on as far as the book of Kings, is a question which, though answered in the affirmative by Schrader and others, cannot be viewed as decided. Even the date of these elements of the Pentateuch is obscure; but in the 8th century Hosea refers quite clearly to passages of both. Thus far there is tolerable agreement among critics; but the Levitical or Elohist history is the subject of violent controversy, which, however, turns mainly on the analysis of the legal parts of the Pentateuch. These contain other elements besides those already enumerated, of which we need only mention the brief code which follows the Decalogue in Exod. xx.—xxiii., and the great repetition of the law in a prophetic spirit which occupies the major part of Deuteronomy. Both these codes may be called popular in tone. They are precepts not for the priests, but for the whole people; and the former is the fundamental sketch of the whole theocratic constitution, which the latter develops and to some extent alters. Now the book of Deuteronomy presents a quite distinct type of style which, as has been already mentioned, recurs from time to time in passages of the later books, and that in such a connection as to suggest to many critics since Graf the idea, that the Deuteronomic hand is the hand of the last editor of the whole history from Genesis to Kings, or, at least, of the non-Levitical parts thereof. This conclusion is not stringent, for a good deal may be said in favour of the view that the Deuteronomic style, which is very capable of imitation, was adopted by writers of different periods. But even so it is difficult to suppose that the legislative part of Deuteronomy is as old as Moses. If the law of the kingdom in Deut. xvii. was known in the time of the Judges, it is impossible to comprehend Judg. viii. 23, and above all 1 Sam. viii. 7. That the law of high places given in this part of the Pentateuch was not acknowledged till the time of Josiah, and was not dreamed of by Samuel and Elijah, we have already seen. The Deuteronomic law is familiar to Jeremiah, the younger contemporary of Josiah, but is referred to by no prophet of earlier date. And the whole theological stand-point of the book agrees exactly with the period of prophetic literature, and gives the highest and most spiritual view of the law, to which our Lord himself directly attaches his teaching, and which cannot be placed at the beginning of the theocratic development without making the whole history unintelligible. Beyond doubt the book is, as already hinted, a prophetic legislative programme; and if the author put

his work in the mouth of Moses instead of giving it, with Ezekial, a directly prophetic form, he did so not in pious fraud, but simply because his object was not to give a new law, but to expound and develop Mosaic principles in relation to new needs. And as ancient writers are not accustomed to distinguish historical data from historical deductions, he naturally presents his views in dramatic form in the mouth of Moses. If then the Deuteronomic legislation is not earlier than the prophetic period of the 8th and 7th centuries, and, accordingly, is subsequent to the elements of the Pentateuchal history which we have seen to be known to Moses, it is plain that the chronology of the composition of the Pentateuch may be said to centre in the question whether the Levitical-Elohistic document, which embraces most of the laws in Leviticus with large parts of Exodus and Numbers, is earlier or later than Deuteronomy. The answer to this question turns almost wholly on archaeological inquiries, for there is, perhaps, no *quite* conclusive reference to the Elohistic record in the prophets before the Exile, or in Deuteronomy itself. And here arises the great dispute which divides critics, and makes our whole construction of the origin of the historical books uncertain. The Levitical laws give a graduated hierarchy of priests and Levites; Deuteronomy regards all Levites as at least possible priests. Round this difference, and points allied to it, the whole discussion turns. We know, mainly from Ezek. xlii., that before the Exile the strict hierarchical law was not in force, apparently never had been in force. But can we suppose that the very idea of such a hierarchy is the latest point of liturgical development? If so, the Levitical element is the latest thing in the Pentateuch, or, in truth, in the historical series to which the Pentateuch belongs; or, on the opposite view, the hierarchic theory existed as a legal programme long before the Exile, though it was fully carried out only after Ezra. As all the more elaborate symbolic observances of the ritual law are bound up with the hierarchial ordinances, the solution of this problem has issues of the greatest importance for the theology as well as for the literary history of the Old Testament.

And now a single word on the way in which these various elements, mirroring so many sides of the national life, and dating from so various ages, came to be fused into a single history, and yet retained so much of their own identity. The Semitic genius does not at all lie in the direction of organic structure. In architecture, in poetry, in history, the Hebrew adds part to part instead of developing a single notion. The temple was an aggregation of small cells, the longest Psalm is an acrostic, and so the longest Biblical history is a stratification and not an organism. This process was facilitated by the habit of anonymous writing, and the accompanying lack of all notion of anything like copyright. If a man copied a book it was his to add and modify as he pleased, and he was not in the least bound to distinguish the old from the new. If he had two books before him to which he attached equal worth, he took large extracts from both, and harmonized them by such additions or modifications as he felt to be necessary. But in default of a keen sense for organic unity very little harmony was sought in points of internal structure, though great skill was often shown, as in the book of Genesis, in throwing the whole material into a balanced scheme of external arrangement. On such principles minor narratives were fused together one after the other, and at length in exile a final redactor completed the great work, on the first part of which Ezra based his reformation, while the latter part was thrown into the second canon. The curious combination of the functions of copyist and author which is here presupposed did not wholly disappear till a pretty late date; and where, as in the books of Samuel, we have two recensions of the text,

one in the Hebrew and one in the Septuagint translation, the discrepancies are of such a kind that criticism of the text and analysis of its sources are separated by a scarcely perceptible line.

*Poetical Books.*—The origin of some leading peculiarities of Hebrew poetry has been recently referred by Assyriologists to Accadian models; but however this may be, the key to the whole development of the poetical literature of Israel is found in the same psychological characteristics of the race which are impressed on the vocabulary and grammatical structure of the language. The Hebrew tongue is sensuous, mobile, passionate, almost incapable of expressing an abstract idea, or depicting a complex whole with repose and symmetry of parts, but fit to set forth with great sibilty individual phases of nature or feeling. It is the speech of a nation whose naturally quick perceptions minister to an emotional temperament and an imperious will, which subordinates knowledge to action and desire, and habitually contemplates the universe through the medium of personal feeling or practical purpose. To speak with the philosophers, the Hebrew character is one of predominant subjectivity, eager to reduce everything to a personal standard, swift to seize on all that touches the feelings or bears directly on practical wants, capable of intense effort and stubborn persistence where the motive to action is personal affection or desire, but indisposed to theoretical views, unfit for contemplation of things as they are in themselves apart from relation to the thinker. In the poetry of such a nation the leading current must necessarily be lyrical, for the lyric is the natural vehicle of intense and immediate personal feeling. The earliest Hebrew poems are brief, pregnant expressions of a single idea, full of the fire of passion, full, too, of keen insight into nature, in her power to awake or sustain human emotion; but recording this insight not with the pictorial fulness of western art, but in swift, half-formed outlines, in metaphor piled on metaphor, without regard to any other principle of proportion or verisimilitude than the emotional harmony of each broken figure with the dominant feeling. Such a poetry could not but find its highest scope in the service of spiritual religion. The songs in Exod. xv. and Judg. v. prove the early origin of a theocratic poetry; but the proper period of Hebrew psalmody begins with David, and its history is practically the history of the Psalter. Here, as in the case of the historical books, we have to begin by questioning the tradition contained in the titles, which ascribe seventy-three Psalms to David, and besides his name as authors Asaph, the sons of Korah, Solomon, Moses, Heman, Ethan. Again the tendency is to refer as much as possible to familiar names. There is no reason to believe that any title is as old as the Psalm to which it is prefixed, and some titles are certainly wrong; for example, the author of the elegy on Saul and Jonathan could not possibly have written Ps. lxxvii., which is a mere cento of reminiscences from other poems. On the other hand the titles are not purely arbitrary. They seem to supply useful hints as to the earlier collections from which our present Psalter was made up. The Korahite and Asaphite Psalms may probably have been derived from collections in the hands of these families of singers; and the so-called "Psalms of David" were very likely from collections which really contained poems by David and other early singers. The assertion that no Psalm is certainly David's is hyper-acceptual, and few remains of ancient literature have an authorship so well attested as the 18th or even as the 7th Psalm. These, along with the indubitably Davidic poems in the book of Samuel, give a sufficiently clear image of a very unique genius, and make the ascription of several other poems to David extremely probable. So, too, a very strong argument claims Psalm ii. for Solomon, and in later times we have sure landmarks in the psalms of Habakkuk (Hab. iii.)

and Hezekiah (Isa. xxxviii.) But the greater part of the lyrics of the Old Testament remain anonymous, and we can only group the Psalms in broad masses, distinguished by diversity of historical situation and by varying degrees of freshness and personality. As a rule the older Psalms are the most personal, and are not written for the congregation, but flow from a present necessity of individual (though not individualistic) spiritual life. This current of productive psalmody runs apparently from David down to the Exile, losing in the course of centuries something of its original freshness and fire, but gaining a more chastened pathos and a wider range of spiritual sympathy. Psalm li, obviously composed during the desolation of the temple, marks, perhaps, the last phase of this development. The epoch of the return was still not without poetic freshness, as some of the so-called Songs of Degrees (Pilgrim-songs) prove. But on the whole the Psalms of the second temple are only reflections of old ideas, cast mainly in directly liturgical form, or at least embodying the experience of the nation rather than of the individual. The date of the latest Psalms is much disputed. Most lines of evidence suggest that the collection was complete before the latest books of the canon were written, but many expositors find in individual Psalms (44, 74, 79, 83, &c.) clear traces of the Maccabean age.

Through the whole period of Hebrew lyric, represented not only by the Psalter, but by the Lamentations, traditionally ascribed to Jeremiah, and by various scattered pieces in Prophets (e.g., Isa. xii.) and in historical books (e.g., Num. xxi. 17; 1 Sam. ii.), there is little change in form and poetic structure. From first to last the rhythm consists not in a rise and fall of accent or quantity of syllables, but in a pulsation of sense, rising and falling through the parallel, antithetic, or otherwise balanced members of each verse. (So-called *Hebrew Parallelism*; better, *Sensory Rhythm*.) Beyond this one law of rhythm, which is itself less an artificial rule than a natural expression of the principle, that all poetic utterance must proceed in harmonious undulation, and not in the spasms of unmodulated passion, the Hebrew poet was subject to no code of art, though strophical arrangements, sometimes marked by a refrain, are not uncommon; while poems of acrostic structure (alphabetic Psalms) are found not exclusively in the most recent literature (Pa. ix., x. form a single undoubtedly old acrostic). The later are on the whole longer than the earlier poems. But this is due not to increased constructive power, but to a diffuser style, a less vigorous unity of feeling and thought, and a tendency to ring many variations on one key. A wider range of artistic power appears in the Song of Solomon, a lyrical drama, in which, according to most critics, the pure love of the Shulamite for her betrothed is exhibited as victorious over the seductions of Solomon and his harem. As the motive of the piece is political as well as ethical, it is most naturally assigned to the early period of the northern kingdom.

The remaining poetical books of the Old Testament belong to a different category. Unfit for abstract speculation, valuing no wisdom that is not practical, and treasuring up such wisdom in sententious rhythmical form,—enforced by symbol and metaphor, and warm with the breath of human interest,—the Hebrew is a poet even in his philosophy. Side by side with the ode the earliest Hebrew literature shows us the *Mashal*, or *similitude*, sometimes in the form of biting epigram (Num. xxi. 27, *f.*) or sarcastic parable (Judg. ix. 8, 2 Kings xiv. 8), sometimes as the natural vehicle of general moral teaching. The greatest name in the early proverbial wisdom of Israel is that of Solomon (1 Kings iv. 32), and beyond doubt many of his aphorisms are to be found in

the book of Proverbs. Yet this book is not all Salomonic. The last two chapters are ascribed to other names, and part of the collection was not put in shape till the time of Hezekiah (xxv. 1), who can have had no infallible criterion of authorship by Solomon, and must not be credited with critical intentions. In truth, the several sections of the book are varied enough in colour to make it plain that we have before us the essence of the wisdom of centuries, while the introductory address in chapters i.—ix. shows how a later age learned to develop the gnomic style, so as to fit it for longer compositions. The fundamental type of Hebrew philosophy remains, however, unchanged, even in the book of Ecclesiastes, which bears every mark of a very late date, long after the Exile. On the other hand, a fresh and creative development, alike in point of form and of thought, is found in the book of Job, which, in grandly dramatic construction, and with wonderful discrimination of character in the several speakers, sums up the whole range of Hebrew speculation on the burning question of Old Testament religion, the relation of affliction to the justice and goodness of God and to the personal merit and demerit of the sufferer. Like the other noblest parts of the Old Testament, the book of Job has a comparatively early date. It was known to Jeremiah, and may be plausibly referred to the 7th century B.C.

In the book of Job we find poetical invention of incidents, attached for didactic purposes to a name apparently derived from old tradition. There is no valid *a priori* reason for denying that the Old Testament may contain other examples of the same art. The book of Jonah is generally viewed as a case in point. Esther, too, has been viewed as a fiction by many who are not over sceptical critics; but on this view a book which finds no recognition in the New Testament, and whose canonicity was long suspected by the Christian as well as by the Jewish Church, must sink to the rank of an apocryphal production.

In the poetical as in the historical books anonymous writing is the rule; and along with this we observe great freedom on the part of readers and copyists, who not only made verbal changes (cf. Pa. xiv. with Pa. liii.), but composed new poems out of fragments of others (Pa. cviii. with lvi. and lx.). In a large part of the Psalter a later hand has systematically substituted Elohim for Jehovah, and an imperfect acrostic, like Pa. ix., x., cannot have proceeded in its present form from the first author. Still more remarkable is the case of the book of Job, in which the speeches of Elihu quite break the connection, and are almost universally assigned to a later hand.

*Prophetic Books.*—We have already seen that the earliest prophecies of certain date are of the 8th century, though there is a probability that Joel flourished in the 9th century, in the reign of Joash of Judah, and that the opening verses of Amos are cited from his book. On the other hand, the old school of prophecy, whose members from Samuel to Elisha were men of action rather than of letters, was not likely to leave behind it any written oracles. The prophets generally spoke under the immediate influence of the Spirit or "hand of Jehovah." What they wrote was secondary, and was, no doubt, greatly abridged. The most instructive account of the literary activity of a prophet is given in Jer. xxxvi. Jeremiah did not begin to write till he had been more than twenty years a prophet. Some prophetic books, like that of Amos, seem to have been composed at one time and with unity of plan. Other prophets, like Isaiah, published several books summing up portions of their ministry. In one or two cases, especially in that of Ezekiel, the prophet writes oracles which were apparently never spoken. Before the Exile there was circulation of individual prophetic books, and earlier prophets quote from their predecessors. But the task of

collecting and editing the remains of the prophets was hardly undertaken till the commencement of the second canon; and by this time, no doubt, many writings had been lost, others were more or less fragmentary, and the tradition of authorship was not always complete. It was, indeed, more important to have an oracle authenticated by the name of its author than to know the writer of a history or a Psalm, and many prophets seem to have prefixed their names to their works. But other prophecies are quite anonymous, and prophets who quote earlier oracles never give the author's name. (A famous case occurs, Isa. xv., xvi., where in xvi. 13, for *since that time* read *long ago*.) Now all the remains of prophecy, whether provided with titles or not, were ultimately arranged in four books, the fourth of which names, in separate titles, twelve authors; while the first three books are named after Isaiah, Jeremiah, Ezekiel, and actually mention no other names in the titles of the several prophecies of which they are made up. But it is safe to assume that every anonymous prophecy in these books must be by the author of the next preceding prophecy which has a title. Certainly any such assumption can only be provisional, and may be overthrown by internal evidence. But internal evidence of date, it is said, cannot apply to prophetic books in which the author looks in a supernatural way into the future. The value of this argument must be tested by looking more closely at the actual contents of the prophetic books. The prophecies contain—1st, reproof of present sin; 2d, exhortation to present duty; 3d, encouragement to the godly and threatening to the wicked, based on the certainty of God's righteous purpose. In this last connection prophecy is predictive. It lays hold of the ideal elements of the theocratic conception, and depicts the way in which, by God's grace, they shall be actually realized in a Messianic age, and in a nation purified by judgment and mercy. But in all this the prophet starts from present sin, present needs, present historical situations. There is no reason to think that a prophet ever received a revelation which was not spoken directly and pointedly to his own time. If we find, then, that after the prophecy of Zechariah i.-viii., which is complete in itself, there begins at ch. ix. a *new* oracle, quite distinct in subject and style, which speaks of an alliance between Judah and Israel as a thing subsisting in the prophet's own time, which knows no oppressor later than Assyria and Egypt, and rebukes forms of idolatry that do not appear after the Exile;—if, in short, the whole prophecy becomes luminous when it is placed a little after the time of Hosea, and remains absolutely dark if it is ascribed to Zechariah, we are surely entitled to let it speak for itself. When the principle is admitted other applications follow, mainly in the book of Isaiah, where the anonymous chapters, xl.-lxvi., cannot be understood in a natural and living way except by looking at them from the historical stand-point of the Exile. Then arises a further question, whether all titles are certainly authentic and conclusive; and here, too, it is difficult to answer by an absolute affirmative. For example, in Isa. xxx. 6, the title, "The burden of the beasts of the south," interrupts the connection in a most violent way. This is not a solitary instance, but on the whole the titles are far more trustworthy in the prophecies than in the Psalms, and partly on this account, but mainly from the direct historical bearing of prophetic teaching, we can frame a completer history of written prophecy than of any other part of Old Testament literature. We have, on the one hand, a series of prophets—Amos, Hosea, and the anonymous author of Zech. ix.-xi.—who preached in the northern kingdom, but are not descendants of the school of Elisha, which had so decayed under court favour from the dynasty of Jehu, that Amos had to be sent from the wilderness of Judah to take up again the forgotten word of the Lord. In Judah proper

we have the great Assyrian prophets, Isaiah with his younger contemporary Micah, the powerful supporters of the reformation of Hezekiah, labouring one in the capital, the other in the country district of the Philistine border. To the Assyrian period belongs also Nahum, who wrote, perhaps, in captivity, and foretold the fall of Nineveh. Then comes Zephaniah about the time of the Scythian ravages, followed by the prophets of the Chaldean period; first Habakkuk and then Jeremiah and Ezekiel, men of a heavier spirit and less glowing poetic fire than Isaiah, no longer upholding the courage of Judah in the struggle with the empire of the East, but predicting the utter dissolution of existing things, and finding hope only in a new covenant—a new theocracy. In the period of Exile more than one anonymous prophet raised his voice; for not only the "Great Unnamed" of Isa. xl.-lxvi., but the authors of other Babylonian prophecies, are probably to be assigned to this time. In the new hope of deliverance the poetic genius, as well as the spiritual insight of prophecy, awakes to fresh life, and sets forth the mission of the new Israel to carry the knowledge of the Lord to all nations. But the spirit of the new Jerusalem had little in common with these aspirations, and in Haggai, Zechariah, and Malachi, prophecy retains not much of its old power except an uncompromising moral earnestness. The noble poetry of the old prophets, which even in the time of Ezekiel had begun to give way to plain prose, finds no counterpart in these latest oracles; and imaginative power is shown, where it still exists, in the artificial structure of symbolic visions. No important new ideas are set forth, and even the tone of moral exhortation sometimes reminds us more of the rabbinical maxims of the fathers in the Mishna, than of the prophetic teaching of the 8th century. And as if the spirit of prophecy foresaw its own dissolution, Malachi looks not to the continued succession of prophets, but to the return of Elijah as the necessary preparation for the day of the Lord. In this sketch of the prophetic writings we find no place for the book of Daniel, which, whether composed in the early years of the Persian empire, or, as modern critics hold, at the time of the Maccabee wars, presents so many points of diversity from ordinary prophecy as to require entirely separate treatment. It is in point of form the precursor of the apocalyptic books of post-canonical Judaism, though in its intrinsic qualities far superior to these, and akin to the prophets proper.

*Further History of the Old Testament Canon in the Jewish Church.*—Under this head we confine ourselves to points which lead up to the reception of the Old Testament by Christendom. These are mainly two:—(1), the history of the Hebrew text, which we now possess only in the recension established by Jewish scribes at a time later than the Christian era; (2), the history of those versions which arose among Jews, but have influenced Christendom.

*The Text of the Old Testament.*—Semitic alphabets have no full provision for distinguishing vowels, and the oldest writing, before orthography became fixed, was negligent in the use even of such vowel-letters as exist. For a long time, then, not only during the use of the old Phœnician character, but even after the more modern square or Babylonian letters were adopted, the written text of the Bible was *consonantal only*, leaving a certain scope for variety of pronunciation and sense. But even the consonantal text was not absolutely fixed. The loose state of the laws of spelling and the great similarity of several letters made errors of copying frequent. The text of Micah, for example, is often unintelligible, and many hopeless errors are older than the oldest versions. But up to the time of the Alexandrian version, MSS. were in circulation which differed not merely by greater or less accuracy of transcription, but by presenting such differences of recension as



could not arise by accident. The Greek text of Jeremiah is vastly different from that of the Hebrew Bible, and it is not certain that the latter is always best. In the books of Samuel the Greek enables us to correct many blunders of the Hebrew text, but shows at the same time that copyists used great freedom with details of the text. For the Pentateuch we have, in the copies of the Samaritans, a third recension, often but not always closely allied to the Greek. The three recensions show important variations in the chronology of Genesis; and it is remarkable that the *Book of Jubilees*, a Jewish treatise, which cannot be much older than the Christian era, perhaps not much older than the destruction of the Jewish state, sometimes agrees with the Samaritan or with the Alexandrian recension. Up to this time, then, there was no absolutely received text. But soon after the Christian era all this was changed, and by a process which we cannot follow in detail, a single recension became supreme. The change was, no doubt, connected with the rise of an overdrawn and fantastic system of interpretation, which found lessons in the smallest peculiarity of the text; but Lagarde has made it probable that no critical process was used to fix the standard recension, and that all existing MSS. are derived from a single archetype, which was followed even in its marks of deletion and other accidental peculiarities. (Lagarde, *Anmerk. sur griech. Uebersetzung der Prov.*, 1863, p. 1; cf. Nöldke in Hilgenfeld's *Zeitschr.*, 1873, p. 446.) Then the received text became the object of farther care, and the Massorets, or "possessors of tradition" with regard to the text, handed down a body of careful directions as to the true orthography and pronunciation. The latter was fixed by the gradual invention of subsidiary marks for the vowels, &c., an invention developed in slightly divergent forms in the Babylonian and Palestinian schools of Jewish scholarship. The vowel points were not known to Jerome, but the system was complete before the 9th century, presumably several hundred years before that time. All printed Bibles follow the Western punctuation, but old Karaitic MSS. with the Babylonian vowels exist, and are now in course of publication. It is from the Massoretic text, with Massoretic punctuation, that the English version and most Protestant translations are derived. Older Christian versions, so far as they are based on the Hebrew at all (Jerome's Latin, Syriac), at least follow pretty closely the received consonantal text.

*Jewish Versions.*—Versions of the Old Testament became necessary partly because the Jews of the Western Dispersion adopted the Greek language, partly because even in Palestine the Old Hebrew was gradually supplanted by Aramaic. The chief seat of the Hellenistic Jews was in Egypt, and here arose the Alexandrian version, commonly known as the Septuagint or Version of the LXX., from a fable that it was composed, with miraculous circumstances, by seventy-two Palestinian scholars summoned to Egypt by Ptolemy Philadelphus. In reality there can be no doubt that the version was gradually completed by several authors and at different times. The whole is probably older than the middle of the 2d century B.C. We have already seen that the text that lay before the translators was in many parts not that of the present Hebrew. The execution is by no means uniform; and, though there are many good renderings, the defects are so numerous that the Greek-speaking Jews, as well as the large section of the Christian church which long depended directly or indirectly on this version, were in many places quite shut out from a right understanding of the Old Testament. Nevertheless, the authority of the version was very great, its inspiration was often asserted, and its interpretations exercised a great influence on Jewish and Christian thought, though among the Jews it was to a certain extent displaced by the version of the

proselyte Aquila (2d century of our era), which followed with slavish exactness the letter of the Hebrew text.

Among the Jews who spoke Aramaic, translations into the vernacular accompanied, instead of supplanting the use of the original text, which was read and then orally paraphrased in the synagogues by interpreters or Methurgemanim, who used great freedom of embellishment and application. This practice naturally led to the formation of written Targums, or Aramaic translations, which have not, however, reached us in at all their earliest form. It used, indeed, to be supposed that the simple and literal Targum of Onkelos on the Pentateuch was earlier than the time of Christ. But recent inquirers have been led to see in it, and in the linguistically cognate Targum on the Prophets (Targum of Jonathan), products of the Babylonian schools, in which the freedom of the early paraphrastic method was carefully avoided. Upon this view the date of these Targums is some centuries after the Christian era. On the other hand, an older style of paraphrase is preserved in the Palestinian Targums, which nevertheless contain in their present form elements later than the Babylonian versions. The Targum of Pseudo-Jonathan on the Pentateuch is apparently the latest form of the free Palestinian version, full of legendary adornments and other additions to the text. Other fragments of Palestinian translation, known as the Jerusalem Targum, and referring to individual passages of the Pentateuch and Prophets, probably represent an earlier stage in the growth of the Aramaic versions. There are also Targums on the Hagiographa, which, however, have less importance, and do not seem to have had so changeful a history. The Targums as a whole do not offer much to the textual critic. They are important, partly from the insight they give into an early and in part pre-Christian exegesis, partly from their influence on later Jewish expositors, and through them on Christian versions and expositions. In some cases the literal or Babylonian Targums have a text differing from the Massoretic. But it is not unlikely that if we had a satisfactory text of the Targums (towards which almost nothing has hitherto been done), these variations would find their explanation in the Eastern text and the Assyrian punctuation.

*NEW TESTAMENT.—Relation of the Earliest Christianity to the Literary and Intellectual Activity of the Age.*—In the literature of Palestine at the time of Christ we distinguish a learned and a popular element. The learned class or scribes were busy on their twofold structure of Halacha, or legal tradition and inference, supplementing and "hedging in" the Pentateuchal law, and Haggada, or fantastic exegesis, legendary, ethical, or theosophic, under which the religious directness of the Old Testament almost wholly disappeared. The popular religious literature of the day seems again to have been mainly apocalyptic. (See APOCALYPTIC LITERATURE.) The people never wearied of these mysterious revelations couched in strange symbolic and enigmatic forms, and placed in the mouths of ancient patriarchs and worthies, which held forth golden visions of deliverance and vengeance in a shape which, because crasser and earthlier, was also more palpable than the spiritual hopes of the old prophets. Beyond the limits of Palestine thought took a wider range. In adopting the Greek language the Hellenistic Jews had also become open to the influences of foreign speculation, and the schools of Alexandria, whose greatest teacher, Philo, was contemporary with the foundation of Christianity, had in great measure exchanged the faith of the Old Testament for a complicated system of metaphysico-theological speculations upon the Absolute Being, the Divine Wisdom, the Logos, and the like, which by the aid of allegorical interpretation were made to appear as the true teaching of Hebrew antiquity.

To these currents of thought the relation of the earliest Christianity, entirely absorbed in the one great fact of the manifestation of God in Christ crucified, risen, and soon to return in glory, was for the most part hostile, when it was not merely superficial. With the spirit of the scribes Jesus had openly joined issue. In the legal tradition of the elders he saw the commandment of God annulled (Matt. xv.) It was His part not to destroy but to fill up into spiritual completeness the teaching of the old dispensation (Matt. v.); and herein He attached himself directly to the prophetic conception of the law in Deuteronomy (Matt. xxii. 37, *f.*) And not only in His ethical teaching but in His personal sense of fellowship with the Father, and in the inner consciousness of His Messianic mission, Jesus stood directly on the Old Testament, reading in the Psalms and Prophets, which so vainly exercised the unympathetic exegesis of the scribes, the direct and unmistakable image of His own experience and work as the founder of the spiritual kingdom of God (*cf.* especially, Luke xxiv. 26, *f.*) Thus Jesus found His first disciples among men who were strangers to the theological culture of the day (Acts iv. 13), cherishing no literature but the Old Testament witness to Christ, and claiming no wisdom save the knowledge of Him. At first, indeed, the church at Jerusalem was content to express its new life in simple exercises of faith and hope, without any attempt to define its relation to the past dispensation, and without breaking with the legal ordinances of the temple. But the spread of Christianity to the Gentiles compelled the principles of the new religion to measure themselves openly with the Judaism of the Pharisees. In the heathen mission of Paul the ceremonial law was ignored, and men became Christians without first becoming proselytes. The stricter Pharisaically-trained believers were horror-stricken. The old apostles, though they could not refuse the right hand of fellowship to workers so manifestly blessed of God as Paul and Barnabas, were indisposed to throw themselves into the new current, and displayed considerable vacillation in their personal conduct. Paul and his associates had to fight their own battle against the constant efforts of Judaizing emissaries, and the rabbinical training acquired at the feet of Gamaliel enabled the apostle of the heathen to meet the Judaizers on their own ground, and to work out the contrast of Christianity and Pharisaism with a thoroughness only possible to one who knew Pharisaism from long experience, and had learned the gospel not from the tradition or teaching of men but by revelation of Jesus Christ (Gal. i. 12).

The relation of the first Christians to the current apocalyptic was of a different kind. The Messianic hopes already current among the first hearers of the gospel were unquestionably of apocalyptic colour. And though the contents of Christian hope were new, and expressed themselves in a revival of prophetic gifts (1 Cor. xii. 10; Acts xi. 27, &c.), it was not a matter of course that apocalyptic forms should be at once dropped, especially as Old Testament prophecy itself had inclined in its later stages towards an increasing concreteness in delineating the Messianic kingdom, and so had at least formed the basis for many apocalyptic conceptions. The apocalyptic books continued to be read, as appears from the influence of the book of Enoch on the epistle of Jude; and after the new spirit of prophecy had died away a Christian apocalyptic followed the Jewish models. But the way in which a genuine Christian prophecy, full of "the testimony of Jesus" (Rev. xix. 10), retained not a little of the apocalyptic manner (mainly, it is true, in dependence on the book of Daniel), appears clearly in the Revelation of John, which, whether we accept the prevalent tradition of its apostolic authorship, or, with some ancients and many moderns, ascribe it to a different John, is at least an undisputed monument of the

prophecy of the apostolic age (according to modern critics, earlier than the fall of Jerusalem).

The influence on Christianity of Hellenistic philosophy, and, in general, of that floating spirit of speculation which circulated at the time in the meeting-places of Eastern and Western thought, was for the most part later than the New Testament period. Yet the Alexandrian education of a man like Apollos could not fail to give some colour to his preaching, and in the epistle to the Hebrews, whose author, a man closely akin to Paul, is not a direct disciple of Jesus (Heb. ii. 3), the theological reflection natural to the second generation, which no longer stood so immediately under the overpowering influence of the manifestation of Christ, is plainly affected in some points by Alexandrian views. In the case of other books the assertion of foreign speculative influences is generally bound up with the denial of the authenticity of the book in question. That the gospel of John presents a view of the person of Christ dependent on Philonic speculation is not exegetically obvious, but is simply one side of the assertion that this gospel is an unhistorical product of abstract reflection. In the same way other attacks on the genuineness of New Testament writings are backed up by the supposed detection of Orphic elements in the epistle of James, and so forth.

*Motives and Origin of the first Christian Literature.*—We have seen that the earliest currents of Christian life and thought stood in a very secondary relation to the intellectual activity of the period. The only books from which the Apostolic Church drew largely and freely were those of the Old Testament, and the Christian task of proclaiming the gospel was not in the first instance a literary task at all. The first writings of Christianity, therefore, were of an occasional kind. The care of so many churches compelled Paul to supplement his personal efforts by epistles, in which the discussion of incidental questions and the energetic defence of his gospel against the Judaizers is interwoven with broad applications of the fundamental principles of the gospel to the whole theory and practice of Christian life. In these epistles, and generally in the teaching of Paul and his associates, Christian thought first shaped for itself a suitable literary vehicle. It was in Greek that the mission to the Gentiles was carried on, for that language was everywhere understood. Already in the mouths of Hellenistic Jews and in the translation of the Old Testament the *κοινή*, or current Greek of the Macedonian period, had been tintured with Semitic elements, and adapted to express the ideas of the old dispensation. Now a new modification was necessary, and soon in the circle of the Pauline churches specifically Christian ideas became inseparably bound up with words which to the heathen had a very different sense. Whether the epistolary way of teaching was used upon occasion by the older apostles before the labours of Paul is not clear; for most scholars have declined to accept the ingenious view which sees in the epistle of James the earliest writing of the New Testament. The other epistles are certainly later, and the way in which several of them are addressed, not to a special community in reference to a special need but to a wide circle of readers, seems to presuppose a formed custom of teaching by letter which extended from Paul not only to so like-minded a writer as the author of Hebrews (Apollos or Barnabas *f.*) but to the old apostles and their associates.

Besides epistles we have in the New Testament a solitary book of Christian prophecy and a fourfold account of the gospel history, with a continuation of the third gospel in the Acts of the Apostles. The origin and mutual relations of the gospels form at the present moment the field of numerous controversies which can only be dealt with in separate articles. We must here confine ourselves to one or two points of general bearing.

Jewish disciples were accustomed to retain the oral teaching of their masters with extraordinary tenacity and verbal exactness of memory (Mishna, *Aboth*, iii. 8; *Edicth*, i. 3), and so the words of Jesus might for some time be handed down by merely oral tradition. But did the gospel continue to be taught orally alone up to the time when the extant gospels were written? or must we assume the existence of earlier evangelical writings forming a link between oral tradition and the narratives we now possess? The earliest external evidence on this point is given in the prologue to Luke's gospel, which speaks of many previous essays towards a regularly digested evangelical history on the basis of the tradition (whether exclusively oral or partly written is not expressed) of eye-witnesses who had followed the whole course of Christ's ministry. It seems to be implied that if the eye-witnesses wrote at all, they, at least so far as was known to Luke, did not compose a regular narrative but simply threw together a mass of reminiscences. This understanding of the words of the evangelist agrees very well with the uniform tradition of the old church as to the second gospel, viz., that it was composed by Mark from material furnished by Peter. This tradition goes back to Papias of Hierapolis, about 150 A.D., but it is a fair question whether the second gospel as we have it is not an enlarged edition of Mark's original work. On the other hand ecclesiastical tradition recognizes the apostle Matthew as the author of the first gospel, but does so in a way that really bears out the statements of Luke. For the tradition that Matthew wrote the first gospel is always combined with the statement that he wrote in Hebrew (Aramaic). But from the time of Erasmus the best Greek scholars have been convinced that the gospel is not a translation. Either, then, the whole tradition of a directly apostolic Aramaic gospel is a mistake, caused by the existence among the Judaizing Christians in Palestine of an apocryphal "Gospel according to the Hebrews," which was by them ascribed to Matthew, but was, in fact, a corrupt edition of our Greek gospel; or, on the other hand, what Matthew really wrote in Aramaic was different from the book that now bears his name, and only formed an important part of the material from which it draws. The latter solution is naturally suggested by the oldest form of the tradition; for what Papias says of Matthew is that he wrote *τὰ λόγια, the oracles*,—an expression which, though much disputed, seems to be most fairly understood not of a complete gospel but of a collection of the words of Christ. And if so, all the earliest external evidence points to the conclusion that the synoptical gospels are non-apostolic digests of spoken and written apostolic tradition, and that the arrangement of the earlier material in orderly form took place only gradually and by many essays. With this the internal evidence agrees. The three first gospels are often in such remarkable accord even in minute and accidental points of expression, that it is certain either that they copied one another or that all have some source in common. The first explanation is inadequate, both from the nature of the discrepancies that accompany the agreement of the three narratives, and from the impossibility of assigning absolute priority to any one gospel. For example, even if we suppose that the gospel of Mark was used by the other two authors, or conversely that Mark was made up mainly from Matthew and Luke, it is still necessary to postulate one or more earlier sources to explain residuary phenomena. And the longer the problem is studied the more general is the conviction of critics, that these sources cannot possibly have been merely oral.

It appears from what we have already seen, that a considerable portion of the New Testament is made up of writings not directly apostolical, and a main problem

of criticism is to determine the relation of these writings, especially of the gospels, to apostolic teaching and tradition. But behind all such questions as the relative priority of Matthew or of Mark, the weight to be assigned to the testimony of Papias, and so forth, lies a series of questions much more radical in character by which the whole theological world is at present agitated. Can we say of all the New Testament books that they are either directly apostolic, or at least stand in immediate dependence on genuine apostolic teaching which they honestly represent? or must we hold, with an influential school of modern critics, that a large proportion of the books are direct forgeries, written in the interest of theological tendencies, to which they sacrifice without hesitation the genuine history and teaching of Christ and his apostles? There are, of course, positions intermediate to these two views, and the doctrine of tendencies is not held by many critics even of the Tübingen school in its extreme form. Yet, as a matter of fact, every book in the New Testament, with the exception of the four great epistles of St Paul, is at present more or less the subject of controversy, and interpolations are asserted even in these. The details of such a controversy can only be handled in separate articles, but a few general remarks may be useful here.

The arguments directed by modern critics against the genuineness or credibility of New Testament books do not for the most part rely much on external evidence. Except in one or two cases (particularly that of 2d Peter) the external evidence in favour of the books is as strong as one can fairly expect, even where not altogether decisive. We shall see when we come to speak of the canon that, towards the close of the 2d century, the four gospels, the Acts, thirteen epistles of Paul, the first epistles of Peter and John, and the book of Revelation, were received in the most widely separated churches with remarkable unanimity. Before this time the chain of evidence is less complete. All our knowledge of the period that lies between the apostles and the great teachers of the Old Catholic Church towards the close of the 2d century is fragmentary. We possess but scanty remains of the literature, and the same criticism which seeks to bring down many New Testament books into this period questions the genuineness of many of the writings which claim to date from the first half of the 2d century, and so are appealed to by conservative writers. But on the whole, what evidence does exist is of a kind to push back all the more important writings to an early date. The gospel of John, for example, is one of the books which negative critics are most determined in rejecting. Yet the fairest writers of the school (Hilgenfeld, Keim) admit that it was known to Justin Martyr in the middle of the 2d century, though they think that besides our four gospels he had a fifth of apocryphal character. But references of an earlier date can hardly be denied; and the gospel may be traced almost to the beginning of the century by the aid of fragments of the Gnostic Basilides and of the epistles of Ignatius. The Tübingen school, indeed, maintain that the fragments preserved by Hippolytus are not from Basilides, but from a later writer of his school, and utterly reject the Ignatian epistles. But it cannot be said that they have proved their case beyond dispute. They have at most shown that, if the gospel *must on other grounds* be taken as spurious, the external evidence may be pushed aside as not absolutely insuperable. On the other hand they try to bring positive proof that certain books were unknown in circles where, if genuine, they must have circulated. But such a negative is in its very nature difficult to prove. Probably the strongest argument of the kind is that brought to show that Papias did not know the gospel of John. But we know Papias only through Eusebius; and though the latter

is careful to mention all references to disputed books, it does not appear that it was part of his design to cite testimony to a book so universally allowed as John's gospel. And Papias does give testimony to the first epistle of John, which is hardly separable from the gospel. On the whole, then, we repeat that, on the most cardinal points, the external evidence for the New Testament books is as strong as can fairly be looked for, though not, of course, strong enough to convince a man who is sure *a priori* that this or that book is unhistorical and must be of late date.

The strength of the negative critics lies in internal evidence. And in this connection they have certainly directed attention to real difficulties, many of which still await their explanation. Some of these difficulties are not properly connected with the Tübingen position. The genuineness of 2d Peter, which, indeed, is very weakly attested by external evidence, was suspicious even to Erasmus and Calvin, and no one will assert that the Pauline authorship of 1st Timothy is as palpable as that of the epistle to the Romans. So, again, it is undeniable that the epistle to the Colossians and the so-called epistle to the Ephesians differ considerably in language and thought from other Pauline epistles, and that their relation to one another demands explanation. But in the Tübingen school all minor difficulties, each of which might be solved in detail without any very radical procedure, are brought together as phases of a single extremely radical theory of the growth of the New Testament. The theory has two bases, one philosophical or dogmatical, the other historical; and it cannot be pretended that the latter basis is adequate if the former is struck away. Philosophically the Tübingen school starts from the position so clearly laid down by Strauss, that a miraculous interruption of the laws of nature stamps the narrative in which it occurs as unhistorical, or, at least, as more cautious writers put the case, hampers the narrative with such extreme improbability that the positive evidence in favour of its truth would require to be much stronger than it is in the case of the New Testament history. The application of this proposition makes a great part of the narrative of the Gospels and Acts appear as unhistorical, and therefore late; and the origin of this late literature is sought by regarding the New Testament as the monument of a long struggle, in the course of which an original sharp antagonism between the gospel of Paul and the Judaizing gospel of the old apostles was gradually softened down and harmonized. The analysis of the New Testament is the resurrection of early parties in the church, each pursuing its own tendency by the aid of literary fiction. In the genuine epistles of Paul on the one hand, and in the Revelation and some parts of Matthew on the other, the original hostility of ethnic and Jewish Christianity is sharply defined; while after a series of intermediate stages the Johannine writings present the final transition in the 2d century from the contents of primitive Christianity to the uniformity of the Old Catholic Church. This general position has been developed in a variety of forms, more or less drastic, and is supported by a vast mass of speculation and research; but the turning points of the controversy may, perhaps, be narrowed to four questions—(1.) Whether in view of Paul's undoubted conviction that miraculous powers were exercised by himself and other Christians (1 Cor. xii. 9, f.; 2 Cor. xii. 12) the miracle criterion of a secondary narrative can be maintained? (2.) Whether the book of Acts is radically inconsistent with Paul's own account of his relations to the church at Jerusalem, and whether the antithesis of Peter and Paul is proved from the epistles of the latter, or postulated in accordance with the Hegelian law of advance by antagonism? (3.) Whether the gospel of John is necessarily a late fiction, or does not rather supply in its ideal delineation of Jesus a necessary

supplement to the synoptical gospels which can only be understood as resting on true apostolic reminiscence? (4.) Whether the external evidence for the several books and the known facts of church history leave time for the successive evolution of all the stages of early Christianity which the theory postulates?

*The Christian Canon of the Old and New Testaments.*—We have already seen that the Apostolic Church continued to use as sacred the Hebrew Scriptures, whose authority derived fresh confirmation from the fulfilment of the prophecies in Christ. The idea that the Old Testament revelation must now fall back into a secondary position as compared with inspired apostolic teaching was not for a moment entertained. Still less could the notion of a body of New Testament Scriptures, of a collection of Christian writings, to be read like the Old Testament in public worship and appealed to as authoritative in matters of faith, take shape so long as the church was conscious that she had in her midst a living voice of inspiration. The first apostolic writings were, as we have seen, occasional, and it was not even matter of course that every epistle of an apostle should be carefully preserved, much less that it should be prized above his oral teaching. Paul certainly wrote more than two epistles to the Corinthians, and even Papias is still of opinion, when he collects reminiscences of apostolic sayings from the mouths of the elders, that what he reads in books cannot do him so much good as what he receives "from a living and abiding voice." Nay, the very writers who are the first to put Old and New Testament books on a precisely similar footing (*e.g.*, Tertullian) attach equal importance to the tradition of churches which had been directly taught by apostles, and so were presumed to possess the "rule of faith" in a form free from the difficulties of exposition that encumber the written word. In the first instance, then, the authoritative books of the Christian church were those of the Old Testament; and in the time of the apostles and their immediate successors it was the Hebrew canon that was received. But as most churches had no knowledge of the Old Testament except through the Greek translation and the Alexandrian canon, the Apocrypha soon began to be quoted as Scripture. The feeling of uncertainty as to the proper number of Old Testament books which prevailed in the 2d century is illustrated by an epistle of Malito of Sardis, who journeyed to Palestine in quest of light, and brought back the present Hebrew canon, with the omission of the book of Esther. In the 3d century Origen knew the Hebrew canon, but accepted the Alexandrian additions, apparently because he considered that a special providence had watched over both forms of the collection. Subsequent teachers in the Eastern Church gradually went back to the Hebrew canon (Esther being still excluded from full canonicity by Athanasius and Gregory of Nazianzus), distinguishing the Alexandrian additions as *ἀνεκλογιστά*—books used for ecclesiastical lessons. In the Western Church the same distinction was made by scholars like Jerome, who introduced for merely ecclesiastical books the somewhat incorrect name of Apocrypha; but a laxer view was very prevalent and gained ground during the Middle Ages, till at length, in opposition to the Protestants, the Council of Trent accepted every book in the Vulgate translation as canonical.

We turn now to the New Testament collection. The idea of canonicity—the right of a book to be cited as Scripture—was closely connected with regular use in public worship, and so the first step towards a New Testament canon was doubtless the establishment of a custom of reading in the churches individual epistles or gospels. The first beginnings of this custom must have been very early. The reference to Luke in 1 Tim. v. 18 is disputed, and

2 Pet. iii. 16 is usually taken as one of many arguments against the genuineness of that epistle; but a citation from Matthew is certainly referred to as Scripture in the epistle of Barnabas. But such recognition of an individual gospel is a long way removed from the recognition of an apostolic canon. The apostolic writings continued to be very partially diffused, and readers used such books as they had access to, often failing to distinguish between books of genuine value and worthless forgeries. For most readers were very uncritical, and there was an enormous floating mass of spurious and apocalyptic literature, including recensions of the gospel altered by heretical parties to suit their own views. It was perhaps in contest with the heretics of the 2d century that the necessity of forming a strict list of really authoritative writings came to be clearly felt; and it is remarkable that heretics, generally hostile to the Old Testament, seem to have been among the first to form collections of Christian writings for themselves. Thus Marcion, in the middle of the 2d century, selected for himself on dogmatical grounds ten Pauline epistles, and a gospel which seems to have been based on Luke. Up to this time perhaps no formal canon of sacred writings had been put forth by the Catholic Church. But in the second half of the century the notion of an authoritative New Testament collection appears in full development, and there is an amount of agreement as to the contents of the canon, which implies that, in spite of the loose way in which apocryphal books circulated side by side with genuine works, the church had no great difficulty in drawing a sharp line between the two classes when this was felt to be necessary. At the time of the great teachers of the close of the 2d century (Irenæus, Tertullian, Clement) we find a twofold collection, the *Gospel and the Apostles*. The Gospel comprises the four evangelists; and this number was already so absolutely fixed as to admit of no further doubt.

Quite beyond dispute were also the main books of the *Apostolicon*, the Acts, thirteen epistles of Paul, 1st Peter, 1st John, and the Apocalypse. The Muratorian fragment which contains a list twenty or thirty years older than the 3d century omits 1st Peter, but adds Jude, 2d and 3d John (!), and (as a disputed book) the Apocalypse of Peter. The Shepherd of Hermas might also be read, but it is pointed out that it is of quite recent date and not of prophetic or apostolic authority. From this time forward, then, the controversy is narrowed to a few books, occupying a middle position between the large mass of our present New Testament, which was already beyond dispute, and the spurious literature which was quite excluded from ecclesiastical use. Absolute uniformity was not at once attainable, for various churches had quite independent usages; and, as we see from the Muratorian canon, a book might receive a certain ecclesiastical recognition without being, therefore, viewed as strictly canonical. This dubious margin to the canon was of very uncertain limits, and Clement of Alexandria still uses many apocryphal books which found no acknowledgment in other parts of the church. Gradually the list of books which have even a disputed claim to authority is cut down. In the time of Eusebius the Shepherd of Hermas was still read in some churches, and several other books—the Epistle of Barnabas, the Acts of Paul, the Revelation of Peter, the Teachings of the Apostles—appear as controverted writings. But all these are plainly on the verge of rejection, while, on the other hand, 2d and 3d John, Jude, James, and 2d Peter are gradually gaining ground. This process continued to go on without interruption till at length the whole class of disputed books (*antilegomena*) melted away, and only our present canon was left on the one hand, and books of no authority or repute upon the other. Thus the Council of Laodicea was able wholly to forbid the ecclesiastical use of uncanonical

books (360 A.D.), and the only uncertain point remaining in the tradition of the Eastern Church was the position of the Apocalypse, which had gradually fallen into suspicion, and was not fully reinstated till the 5th century. The Western Church, on the other hand, was long dubious as to the epistle to the Hebrews, which was received without hesitation in the East, as the Apocalypse continued to be in the West. The age of Augustine and Jerome saw the close of the Western canon.

*Transmission and Diffusion of the Bible in the Christian Church before the Invention of Printing.*

Under this head we have to speak—1st, of the transmission of the original text; 2d, of the ancient versions.

1. THE ORIGINAL TEXT.—*Old Testament*.—The rapid spread of Christianity among the Gentiles of the West made Greek the sacred language of Christendom. Not only is Greek the language of the New Testament, but it was in the Septuagint version that the Old Testament was first circulated in the most important Gentile churches. Hebrew was almost unknown even to learned Christians, and in fact the current (Jewish as well as Christian) doctrine of the inspiration of the Septuagint, and a suspicion that the Hebrew text had been falsified by the Jews, made the study of the original appear unprofitable. A juster view of the value of Hebrew studies was formed by the two greatest scholars of the patristic period, Origen and Jerome. But the Septuagint continued to enjoy an authoritative place in the Eastern Church; and the Latin Church, though it finally adopted Jerome's translation from the Hebrew in place of the older translation from the Greek, was not led by this change to take any interest in further study of the original. The Hebrew Bible continued to be the peculiar possession of the Jews, of whose labours in fixing and transmitting a standard text we have already spoken. It was not till the beginning of the 16th century that Christian scholars began to take a lively interest in the "Hebrew verity;" and what has been done since that time to repair so many centuries of neglect belongs to the history of the printed text or of exegesis.

*New Testament*.—The original copies of the New Testament writings were probably written on papyrus rolls, and were so soon worn out by frequent use, that we do not even possess any historical notice of their existence. They must, however, have been written in *uncial* or large capital letters, without division of words or punctuation, without accents, breathings, &c., and probably without any titles or subscriptions whatever. The earliest transcripts comprised only portions of the New Testament, the gospels being oftener copied, and the Pauline oftener than the catholic epistles. Even after the canon became fixed, MSS. of the whole New Testament, or of the whole Greek Bible, were comparatively rare. The order of the several books was not quite fixed; but the catholic epistles generally followed the book of Acts. It may also be noted that in the oldest MSS. the epistle to the Hebrews precedes the pastoral epistles. In course of time various changes were introduced in the externals of the written text. Parchment and vellum took the place of papyrus, and form the material of the oldest extant copies. The uncial character held its ground till about the 10th century, when the use of a *cursor* or running hand became general. Attempts to indicate the punctuation go back as far as the 4th or 5th century. The oldest MSS. use for this purpose an occasional simple point, or a small blank space in the line. Another system was to write the text in short lines (*επιχει*) accommodated to the sense. The author of this *stichometry* was Euthalius of Alexandria in the second half of the 5th century, who applied it to the epistles and Acts. The same plan was afterwards extended to the gospels; but vellum was too costly to allow of its general adoption. The present system of punctuation was first used in printed books. Breathings and accents were not in common use down to the end of the 7th century; but occasional traces of them seem to occur considerably earlier.

Another device for the more convenient use of the New Testament was the division of the text into sections of various kinds. The gospels were divided by Ammonius of Alexandria (320 A.D.) into short chapters (Ammonian sections, *κεφάλαια*), constructed to facilitate the comparison of corresponding passages of the several gospels. These sections are marked on the margin of most MSS. from the 5th century onwards; and in general a reference is also given to the so-called canons of Eusebius, which are a kind of index to the sections, enabling the reader to find the parallel passages. Another division of the gospels into larger sections (*επιφύλαξ*, *βιβρα*) is also found in MSS. of the 5th century, and a similar division of the other books into chapters (*κεφάλαια*) came into use not much later. The chapters of the Acts and the catholic epistles were the work of Euthalius. Our present chapters are much later. They were invented by Cardinal Hugo of S. Carus in the 13th century, were first applied to the Latin Bible, and are still unknown in the

Eastern Church. The present system of verses first appears in the edition printed by Robert Stephens in the year 1551.

The titles and subscriptions of the New Testament books are another point on which a succession of changes has taken place. The oldest MSS. have much shorter titles than those which the English version adopted from the later Greek text; and the subscriptions, with their would-be historical information, are not only late, but worthless. Those appended to the epistles of St Paul are attributed to Euthalius.

More important than these external matters are the variations which in course of time crept into the text itself. Many of these variations are mere slips of eye, ear, memory, or judgment on the part of a copyist, who had no intention to do otherwise than follow what lay before him. But transcribers, and especially early transcribers, by no means aimed at that minute accuracy which is expected of a modern critical editor. Corrections were made in the interests of grammar or of style, slight changes were adopted in order to remove difficulties, additions came in, especially from parallel narratives in the gospels, citations from the Old Testament were made more exact or more complete. That all this was done in perfect good faith, and simply because no strict conception of the duty of a copyist existed, is especially clear from the almost entire absence of deliberate falsification of the text in the interests of doctrinal controversy. To detail all the sources of various readings would be out of place; it may suffice to mention, in addition to what has been already said, that *glosses*, or notes originally written on the margin, very often ended by being taken into the text, and that the custom of reading the Scriptures in public worship naturally brought in liturgical additions, such as the doxology of the Lord's Prayer; while the commencement of an ecclesiastical lesson torn from its proper context had often to be supplemented by a few explanatory words, which soon came to be regarded as part of the original.

Up to a certain point the various readings due to so many different causes constantly became more and more numerous; but the number of independent readings which could arise and be perpetuated was limited by various circumstances. A general similarity necessarily prevailed in associated groups of copies, which were either derived from the same archetype, or written by the same copyist, or corrected by comparison with a single celebrated MS. Causes such as these, combined with local peculiarities of style and taste, and with the fact that the New Testament, like Christianity itself, was sent forth from central mother churches to newly-formed communities all around, gave a decided local colouring to the text current in certain regions; so that we are still able to speak in a general way of an Alexandrian, a Western, a Byzantine, and perhaps also (with Tischendorf) of an Asiatic text. But of course no ancient local text remained uninfluenced by copies from other regions. The comparison of copies became more and more extended in range as the church grew and consolidated into a homogeneous form; and though old readings, which had obtained a firm hold in certain communities, were not easily eradicated, it at length became almost impossible for any important new error to escape detection. Most variations of any consequence which are found in existing MSS. are known to be as old as the 4th century, and other readings existed then which no MS. is known to contain.

The variations of early copies were most completely smoothed into uniformity in the later Byzantine MSS., after the Mahometan conquest had overthrown Greek learning in Syria and Egypt. The scribes of Constantinople spent great pains on the text in accordance with their own notions of what was proper, and gave it a form which is certainly smoother, correcter, and more uniform than that of older MSS. But precisely these peculiarities show that this late recension is remote from the original shape of the New Testament writings, and compel us to seek the true text by study of early MSS., especially of the still existing uncial copies.

The manuscripts are of six classes, containing respectively the gospels, the Acts with the catholic epistles, the Pauline epistles, the Apocalypse, the ecclesiastical lessons from the gospels, the lessons from the Acts and epistles. Copies belonging to the last two classes are called lectionaries, and lectionaries of the gospels are called evangelistaria. Each MS. is referred to by critics by a special mark. Uncial MSS. are denoted by a capital letter, A standing for the Codex Alexandrinus, B for the Vaticanus, and so on. Curatives and lectionaries are denoted by Arabic numerals. It is to be observed that the same letter in a different part of the New Testament does not necessarily refer to the same MS. Thus Cod. D of the gospels and Acts is the Codex Bezae, but D of the Pauline epistles is the Claromontanus. If we reckon fragments, the number of uncial MSS. is 56 of the gospels, 14 of the Acts, 6 of the catholic epistles, 15 of the Pauline epistles, 5 of the Apocalypse. But many of these are extremely short fragments. The number of curatives and lectionaries is enormous, so that altogether there are nearly a thousand MSS. for the gospels, and as many more for the rest of the New Testament. Not nearly all the curative copies have been thoroughly examined, and most of them have small value, though some comparatively recent MSS. are important from the

fact that they represent an ancient text. Lectionaries, even when uncial, are little esteemed by most critics. Græco-Latin codices which have the Greek and Latin in parallel columns were formerly suspected of correcting the Greek text by the Latin, but their value is now generally recognized.

The oldest copies of the Greek Testament are the Codex Sinaiticus (M) and the Codex Vaticanus (B), both of the 4th century. Next in age come the Alexandrian manuscript (A) and the Codex Ephraemi (C), both of which are referred to the 5th century. All of these copies were originally complete Bibles, with the Old as well as the New Testament. M is still complete as regards the New Testament; A and B have lacunæ; C is very imperfect, and barely legible, the ancient writing having been almost removed by a mediæval scribe to make way for the writings of Ephraem Syrus. M, A, B, C, are the four great first-rate uncials, and will be found more fully described in separate articles. Besides these there are one or two fragments as old as the 5th century (I, P, T).

A quite peculiar place is held by the Græco-Latin Codex Bezae at Cambridge (D), which dates from the 6th century, but presents a text full of the most singular interpolations. The other uncials of the gospels are less important, either from their fragmentary state or from the character of their text. The later uncials are hardly more valuable than good cursives.

The most important MS. of the Acts, in addition to those already mentioned, is E, the Codex Laudianus, Græco-Latin of the 6th century, in the Bodleian at Oxford. For the Pauline epistles we may mention D, or Codex Claromontanus, at Paris, also Græco-Latin of the 6th century, and H, or Codex Coliniensis, of the same century, of which there are 12 leaves at Paris and 2 at St Petersburg. Uncial authority is most scanty for the Apocalypse, for which the Vaticanus is defective. B of the Apocalypse is an uncial of the 8th century.

2. THE CHRISTIAN VERSIONS.—We have seen that the early church adopted the LXX., not so much in the character of a version, as in that of an authoritative original. Although several attempts were made in the 2d century of our era to produce a better Greek rendering of the Old Testament, not one of these seems to have had its origin in the Catholic Church. Aquila was a Jew, whose closely verbal rendering was designed to serve the subtilties of Rabbinic exegesis. Symmachus and Theodotion were probably Ebionites. The former was an excellent master of Greek, who happily corrected many clumsy renderings of the LXX., but inclined too much to paraphrase, and to the obliteration of characteristic figures and bold expressions. Theodotion made less extensive changes, and aimed only at necessary corrections. His rendering of Daniel was so manifest an improvement that it entirely displaced the old version, and is still regularly printed as part of the LXX.

In the Christian Church the importance of these new versions, and the unsatisfactory condition of the LXX.—which, apart from its original defects, had been much corrupted in successive transcriptions—were first clearly set forth by Origen in his Hexaplar edition of the Old Testament. This great work takes its name from the six columns in which it was arranged, containing respectively the Hebrew in the proper character, the same in Greek letters, the versions of Aquila, Symmachus, and Theodotion, and a text of the LXX., partly corrected by comparison of MSS., partly emended by recourse to the Hebrew. The variations of several less important versions were also noted. The complete Hexapla was too huge a work to be transcribed and circulated as a whole. It lay in the library at Caesarea, and was only occasionally consulted by scholars; but the column containing Origen's emended text of the LXX. was published in separate transcripts by Eusebius and Pamphilus, and attained so great a circulation that in the Palestinian churches, as we learn from Jerome, it quite displaced the older text. In composing his Hexaplar text, Origen was careful to distinguish his own improvements from the original LXX. by the use of asterisks and other marks. In later copies these marks were unfortunately often omitted. The Hexaplar text became mixed up with the true LXX., and the modern critic is sometimes tempted to forget how much the Eastern Church owed to this first attempt to go back to the Hebrew Old Testament, in his impatience at the obliteration by the adoption of Hexaplar corrections of important divergences of the LXX. from the Massoretic text. Our knowledge of the other columns of Origen's great edition is fragmentary, and is derived partly from citations in ancient authors, partly from notes in MSS. of the Hexaplar LXX., or of the Syriac translation of it composed by Paul of Tala (616 A.D.). The best collection of these fragments is that edited by Field (*Origenis Hexaplorum quæ supersunt*, Oxford, 1867-1875).

The first origin of translations of the Christian Scriptures into the vernacular of non-Hellenic churches is involved in much obscurity. Apart from the probable existence of early Aramaic gospels, there is no sure trace of a Christian literature in any other tongue than Greek till late in the 2d century. Even in the churches of Gaul, Greek was the recognized language of Christian authorship. In Rome the literary use of Greek extended into the 3d century; and in the earliest days of the Roman Church, Greek was the language of public worship. Even in remotest districts the demand

for a vernacular Bible can hardly have come from the educated and reading classes, but arose rather from the custom of reading lessons from Scripture in the congregation. The earliest Christian translations are the Peshito or "Simple" version in Syria, and the Old Latin in Africa, monuments of the early vigour of two great churches on the eastern and western outskirts of Hellenic culture.

It is scarcely probable that either of these versions is older than the middle of the 2d century. The Syriac, which claims to be first considered, was already an old version, containing obsolete expressions, in the time of S. Ephraem, who died 373 A.D. Internal marks of antiquity are found in the relation of the Old Testament to a very early Jewish exegesis, and especially in the omission from the New Testament of 2 Peter, 2 and 3 John, Jude, and Revelation. On the other hand, there is no certain reference to this version by authors earlier than Ephraem; and the data afforded by the history of the canon, and by a comparison of the earliest remains of Syriac literature—the hymns of Bardesanes, who died about 225—are not sufficient to supply the lack of direct information. Some critics still date the version from the beginning of the 2d century, while others would bring it down into the 3d. Even the close of the 3d century has been named; but this view rests on the unlikely supposition that the omission of five New Testament books was due to later theological influences, and was not an original peculiarity of the version. The translation is, on the whole, excellent. The Old Testament is taken from the Hebrew, and, though sometimes dependent on Jewish exegesis, and in other parts strongly influenced by the LXX., is decidedly superior to the Targums. The Peshito was the received version in all branches of the much-divided Syrian churches. But it did not stand alone. The Hexaplar version of Paul of Tala, and the slavishly literal Philoxenian (508 A.D.—revised a century later by Thomas of Harkel), were presumably designed in the service of Biblical criticism. More obscure is the origin and purpose of the fragmentary version of the gospels published by Cureton in 1858, and by him supposed to be older than the Peshito.

In the history of the Old Latin version almost nothing is certain, save that it originated in Africa, before the time of Tertullian, and that it assumed such Protean shapes in the hands of transcribers that it is to this day uncertain whether several distinct versions are not included in the general name of the Old Latin. Jerome, indeed, speaks only of great variations between copy and copy; but Augustine tells us that the "Itala" is to be preferred to the other Latin interpretations. Hence MSS. of the Old Latin are often called copies of the Itala; but in truth no one knows what the Itala is, for it is mentioned only by Augustine, and by him only once.

A version which at best was a rude and over-literal rendering of the Greek Bible, in an unpolished provincial dialect, and which had not even that fixed form which is so necessary in a Bible for ecclesiastical use, could not continue to serve the needs of the great Latin Church; and towards the close of the 4th century a work of revision was undertaken at the instance of Damasus, bishop of Rome, by Jerome, the most learned of the Western doctors. Jerome began by correcting the New Testament, making only such changes as seemed absolutely imperative. In the Old Testament he first revised the Psalter after the LXX., producing the version known as the Roman Psalter from its adoption in the Roman liturgy. A second revision, based on the Hexaplar text, forms the Gallican Psalter, long used in Gaul and other churches beyond the Alps. Then Jerome proceeded to revise other books on the basis of the Hexaplar Greek; but, finding this half-measure unsatisfactory, he finally rendered the Old Testament directly from the Hebrew. The work was completed 405 A.D., and though often dependent on Aquila, and especially on Symmachus, it bears high witness to the scholarship of the author, and is perhaps the best of the ancient versions. In spite of its merits the new version was much attacked, and made way in public estimation by very slow degrees. It was not till the 9th century that the Old Latin was entirely superseded in the Roman Church, and the circulation of the old and new versions side by side was long a fertile source of corruptions in the text of both. At length the complete supremacy of Jerome's Latin was marked by the transference to it of the name of the *Vulgate Version*, which in older times was given to the LXX.

The Egyptian versions (Memphitic in the dialect of lower Egypt, Thebaic or Sahidic for upper Egypt) supplied the needs of the only great Christian population of the early church which was not able to use the Greek, the Latin, or the Syriac. The most recent inquirers are disposed to believe that Egypt received the Bible in the vernacular almost as soon as Syria. The version was taken from the Greek, which was also the source of various later translations—the Ethiopic, the Armenian (5th century), the Georgian (6th century), the Slavonic (9th century)—fruits of the gradual diffusion of Christianity in the remotest regions of the ancient world. The Gothic version of Ulfilas—the earliest written monument of the Teutonic languages—is of the 4th century, and was also from the Greek. Only fragments of this translation remain to us, mainly in the famous silver-lettered MS. of the 5th or 6th century (*Codex Argenteus*) in the library of Uppsala.

Thus far the history of the versions records the triumph of Christianity. The Arabic versions, on the contrary, owe their origin to the spread of Islam, when the language of the conquering Saracens displaced the ancient dialects of Syria and Egypt. This change did not diminish the authority of the old ecclesiastical versions, or displace them from their position in the services of the church. The edification of the unlearned was secured by reading the lessons in the vulgar tongue, as well as in Syriac or Coptic; and, accordingly, the numerous Christian Arabic versions are mainly taken not from the original tongues, but from the versions whose use they were designed to supplement. In like manner the rise of the New-Persian language and literature produced a Persian version of the Syriac New Testament. Of parts of the Old Testament there are Arabic and Persian translations directly from the Hebrew, but these are the work of Jewish scholars. The Arabic versions of the Pentateuch and Isaiah, by R. Saadiah Gaon, in the 10th century, are among the most important monuments of ancient Jewish learning.

In the West as in the East the disintegration of the Roman empire was associated with the rise of new national dialects, and Latin ceased to be understood by the laity. But the Roman Church was too intent on the preservation of her homogeneous organization, her visible unity of worship, to allow the vulgar tongues to supplant the old liturgical language, or even to introduce a bilingual service. The use of the Bible in a form intelligible to the illiterate was shifted from the sphere of public worship to that of private edification and instruction; and for the latter purpose the necessities of a barbarous age seemed to demand explanatory paraphrases, Bible narratives in metre, and the like, rather than literal renderings of the whole Scriptures. Thus, in the Anglo-Saxon Church, Caedmon's poetical version of the Bible history dates from 664 A.D., while the earliest prose translations of parts of the Latin Bible (gospels, psalms, &c.) do not seem to be older than the 8th century. In Germany, in like manner, metrical versions of the gospel are among the earliest attempts to convey the Bible to the people. Otfrid's harmony of the gospels in High German, and the poem called *Heliand* (Saviour), in Old Saxon, date from the 9th century; and the prose translation of the so-called Gospel Harmony of Tatian—from the Latin of Victor of Capua—belongs to the same age. A complete and literal translation of the Vulgate existed in Germany perhaps as early as the beginning of the 14th century. Among nations whose speech was descended from the vulgar Latin, the work of translation naturally began later. The earliest remains of Romance versions are thought to be as old as the 11th century; but the work of translation assumed important dimensions mainly in connection with the spirit of revolt against the Church of Rome which rose in the 13th and 14th centuries. The study of the Bible in the vulgar tongue was a characteristic of the Cathari and Waldenses, and the whole weight of the church's authority was turned against the use of the Scriptures by the laity. The prohibition of the Bible in the vulgar tongue, put forth at the Council of Toulouse in 1229, was repeated by other councils in various parts of the church, but failed to quell the rising interest in the Scriptures. In England and in Bohemia the Bible was translated by the reforming parties of Wyclif and Huss; and the early presses of the 15th century sent forth Bibles, not only in Latin, but in French, Spanish, Italian, German, and Dutch.

#### The Printed Text.

Though the Latin Bible was the first book printed, the original text was for some time neglected. The Jews of Italy led the way with several editions of parts of the Old Testament, commencing with the Psalter of 1475. The beautiful edition of Somcino (1488) was the first complete Hebrew Bible, and was soon followed by the edition of Brescia, used by Luther (1494). At length Christians interested themselves in the work. The Antwerp printer, Daniel Bomberg, established a Hebrew press in Venice, from which he sent forth a series of Bibles and other books. The famous Rabbinical Bible of 1517, edited by Felix Pratensis, a converted Jew, is known as the first Bomberg Bible, and is especially valuable for the text of the Targums, which it prints in parallel columns with the Hebrew. The second Rabbinical Bible of Bomberg was edited by R. Jacob Chayim (who also became a Christian), and contains the first printed edition of the Massora, with a text carefully corrected in accordance with Massoretic precepts. This edition at once attained a great reputation. It was several times reprinted, and most subsequent editions are directly or indirectly dependent on it. The only early edition which rivals its fame is the Complutensian Polyglott, published at Alcalá in 1517, at the expense of Cardinal Ximenes. The Hebrew of this polyglott exhibits a peculiar text, independent of the Italian editions. Later editions of the Hebrew Bible present little or no advance on the early prints; and most recent editions are decidedly inferior. Of Hebrew Bibles, with various readings from MS. authority, the best known are Kennicott's (Oxford, 1776, 1780) and De Rossi's (Parma, 1784—1798). The latter collection is by far the best, but neither has done much for the improvement of the text. In fact the differences between really good MSS. are

generally very minute; and where the current text is corrupt it is not from MSS., but from the versions, or from conjecture, that help must be sought. On the other hand, a more accurate edition of the Masoretic text is certainly wanted. But such an edition must pay special regard to vowel points and accents, which Kennicott and De Rossi neglect, and must consult MSS. of the Masora as well as of the text. The most valuable edition which notes variations not affecting the consonantal text is the Mantuan Bible of 1742, 1744, with the notes of Norzi (R. Jeddiah Solomon of Norcia). The best recent texts are E. Beza's Leipzig editions of Genesis (1869), Psalms (1861), and Isaiah (1872). Among easily accessible editions of the whole Old Testament, those of Jablonaky (Berlin, 1699) and J. H. Michaëlis (Halle, 1730) have the best reputation.

The Greek New Testament was first printed in the Complutensian Polyglott (1514), but a delay in the publication enabled Froben of Basel to preoccupy the market with an edition hastily prepared by Erasmus from very recent codices. In subsequent editions a good many changes were made, partly after the Complutensian text, and in the third edition (1522) the spurious passage, I John v. 7, appeared for the first time. But it was still a recent and therefore an unsatisfactory text that was represented, and this radical defect was not corrected by the editors who followed Erasmus, though some of them, and notably Th. Beza, possessed, and to some extent used, better MSS. than Erasmus consulted. Their beauty and convenience, rather than the merit of their text, procured a great currency for the editions of Robert Stephens (*O sinesion* editions, 1546, 1549; royal edition, 1550), and his text of 1550, or the Elzevir text of 1624, which, though mainly based on Beza, is very nearly identical with the other, came to be regarded as the "received text," which subsequent editors were long afraid to change. But materials for a better text were gradually accumulated by Walton in the London Polyglott (1657), Curcellanus (1658), Fall (1675), and above all by John Mill in his great edition of 1707. These labours were viewed with much jealousy by the hyper-orthodox; and even as late as 1751, Wetstein, after long and most valuable studies, could find a publisher only on consideration that his amendments on the received editions should not stand in the text. Some important steps, however, were taken in the interval between Mill and Wetstein. Bentley sketched in 1720 the plan of an edition which should restore the text of the 4th century; and Bengel in 1784 actually published an amended text, though readings which had not been given in any previous edition were admitted only in the Apocrypha. Bengel was the first who classed MSS. under families, as Asiatic and African respectively. The next great critical editor after Bengel and Wetstein was J. J. Griesbach, whose chief edition appeared 1796, 1806. Griesbach gave an exaggerated importance to the doctrine of families of MSS.; and his edition was constructed on the principle of adhering to the received text, unless the reasons to the contrary were irresistible; but his industry and critical skill give him a very high place among editors. Griesbach was followed by the Roman Catholic Scholz, whose labours were more pretentious than valuable; and at length the great critic Lachmann (1842, 1850) threw aside all traditional respect for the received text, and sought to restore the text of the 4th century by the aid of a very small number of select MSS., together with the Latin versions as given in the oldest copies, and the citations of the earliest fathers. The idea was fruitful, though the material employed was too scanty. Since Lachmann published his edition our knowledge of the most ancient authorities has been greatly increased. New MSS. have been added, notably Tischendorf's *M*; and the MSS. formerly known have been edited or collated with much greater accuracy. The most distinguished labourers in this work were Tischendorf and Tregelles. In addition to numerous editions and collections of ancient copies, Tischendorf put forth a series of critical editions, of which the eighth (Leipzig, 1865-1872) contains the completest critical commentary yet published. The great edition of Tregelles (1857-72) rests exclusively on the most ancient authority, resembling Lachmann's work in conception, though using much more copious materials. This edition, as well as Tischendorf's VIII., lacks the *prolegomena*, both editors having been struck down by paralysis before their work was complete.

The recent versions, subsequent to the invention of printing and the revived study of the original tongues, demand a word in conclusion. New Latin versions naturally accompanied many of the early editions of the original text. Thus Kramus gave many corrections of the Vulgate in his Greek Testament, the Complutensian gives an interlinear version of the LXX, the Genoa Polyglott Printer of 1516 gives renderings both of the Hebrew and of the Chaldeæ. Even such works as these, designed as they were for scholars, gave offence from their appearance of undermining the authority of the Vulgate; and it was the Reformation, in its revolt against mere human authority, that first demanded open circulation of vernacular versions from the original tongues. From the time of Luther's version (New Testament, 1522; complete Bible, 1534) we may distinguish four classes of versions.

1st. Versions adopted by Protestant countries or churches. Such

are Luther's Bible in Germany; the Dutch Bible of the Consensus of the Synod of Dort, 1637; the English Authorized Version of 1611; the Geneva French Bible, formed by successive revisions of Olivetan's version of 1535; the Danish of 1550, based on Luther, revised in 1607, 1647; the Swedish, 1541. Most of these national Bibles were preceded by earlier Protestant versions, which they superseded. See especially *ERASMUS BILINGUA*. Revisions of the national versions have of late years been undertaken in Norway, Holland, and Germany, as well as in England.

2d. Versions which never held any other place than that of private contributions to Biblical exegesis. Such are—among older works—the Latin Old Testament of Junius and Tremellius, and the New Testament of Beza. These versions belong to the history of exegesis.

3d. Missionary versions.

4th. Roman Catholic versions. The Council of Trent declared the Vulgate version authentic, and forbade interpretations of Scripture not in conformity with the consent of the fathers. Vernacular versions subject to these restrictions were published as the antidote to Protestant Bibles. Such are the Rheinish and Douay versions in English. Other Roman Catholic versions owe their origin to evangelical tendencies within the church. Jamesian, in particular, produced the French version of De Bezy (Mons, 1647), and otherwise stimulated the study of Scripture.

*Literature.*—Full discussion of some of the topics glanced at in this article must be sought in treatises on individual books or critical problems of the Old and New Testament. But on most points it will be sufficient to refer to works on Biblical Introduction. The history of this branch of theology with lists of the principal older books—some of which, including the writings of R. Simon, Carpov, and Eichhorn, are still of value—is given in most recent works on the subject. Of these it may be sufficient to mention for the Old Testament—De Wette's *Einführung*, rewritten by Schrader (Berlin, 1869), full of condensed information; Bleek's posthumous *Einführung* (3d edition, 1870), less complete in detail and now rather behind date, but very clear and instructive; Keil's *Einführung* (3d edition, 1873), which is strictly conservative. The two last are translated. Kuenen's *Historisch-Kritisch Onderzoek*, of which there is a French translation, is very full, but the author has considerably changed his views in the *History of the Religion of Israel* (Haarlem, 1869-70) of which there is an English translation. Ewald's *History of Israel* is important, and is also accessible to the English reader; with it must be taken his books on the *Prophecy* and *Books of the Old Covenant*. Recent English literature on the Old Testament is not very remarkable, but Dr S. Davidson's *Introduction* gives a full account of foreign investigations. The history of the Old Testament in the Christian church has been written by L. Diestel (*Geschichte des Alten Testaments*, u.s.w., Jena, 1869). For the New Testament, De Wette, Bleek, and Davidson may again be consulted. A very instructive book is Reuss's *Geschichte der Heiligen Schriften Neuen Testaments* (5th edition, Brunswick, 1874). The most recent general work proceeding from the Tübingen school is Hilgenfeld's *Historisch-Kritische Einführung in das Neue Testament* (Leipzig, 1875). On the canon there are several important works by Credner in German, and an English *History of the Canon of the New Testament*, by Dr Westcott (4th edition, 1875). On the text of the New Testament the English reader may consult Tregelles's volume, contributed to Horne's *Introduction* (1856), and Scrivener's *Plain Introduction to the Criticism of the New Testament* (2d edition, 1874). Le Long's *Bibliotheca Sacra*, continued by Masch (Halle, 1778-1790), gives a full account of editions of the original text and versions, which may be supplemented by reference to De Rossi's *Annales Hébraïo-typographiques* (XV. Cent., Parma, 1795; MDI. to MDXL., Parma, 1799), and Rossi's *Bibliotheca Novi Testamenti Græci* (Brunswick, 1872). Detailed references to other recent books will be found in the works already cited. (w. r. a.)



**BIBLE SOCIETIES**, associations for extending the circulation of the Holy Scriptures. For a long period this object has been pursued to a considerable extent by several religious institutions, such as the Society for the Propagation of the Gospel in Wales, formed by the Rev. Thomas Gouge, one of the two thousand ministers ejected by the Act of Uniformity in 1662; the Society for Promoting Christian Knowledge, founded in 1698; the Society for sending Missionaries to India, established in the year 1705 by Frederick IV., King of Denmark, and which numbered among its agents the celebrated missionary, Christian Frederick Schwartz; the Society for Promoting Christian Knowledge in the Highlands and Islands of Scotland, formed in Edinburgh in 1709; the Moravian Missionary Society, founded in 1732; the Book Society for Promoting Religious Knowledge among the Poor, which was formed in London in 1750, and numbered among its earliest friends Dr Doddridge and the Rev. James Hervey; and the Religious Tract Society, founded in 1779. But the first British association which had in view the single purpose of disseminating the Scriptures was the **NAVAL AND MILITARY BIBLE SOCIETY**, established in the year 1780, which has done immense service to the army and navy of Great Britain. The sphere of its operations, however, was comparatively limited, and in 1804 the **BRITISH AND FOREIGN BIBLE SOCIETY**, the greatest agency ever devised for the diffusion of the Word of God, was founded. The proposal to institute this association originated with the Rev. Mr Charles Pala, whose philanthropic labours in Wales were greatly impeded by the scarcity of the Scriptures in the principality, and it was largely fostered at the outset by members of the committee of the Religious Tract Society. The exclusive object of the British and Foreign Bible Society is to promote the circulation of the Scriptures, both at home and abroad, and its constitution admits the co-operation of all persons disposed to concur in its support. The committee of management consists of 36 laymen, 6 of them being foreigners resident in or near the metropolis, and of the remaining 30, one-half are members of the Church of England, and the other half members of other Christian denominations.

The proceedings of this society gave rise to several controversies, one of which related to the fundamental law of the society to circulate the Bible alone without notes or comments. On this ground it was vehemently attacked by Bishop Marsh and other divines of the Church of England, who insisted that the Prayer-Book ought to be given along with the Bible. Another controversy, in which the late Dr Andrew Thomson of Edinburgh took a prominent part, related to the circulation on the Continent, chiefly by affiliated societies, of the Apocrypha along with the canonical books of Scripture. In 1826 it was resolved by the committee that the fundamental law of the society be fully and distinctly recognized as excluding the circulation of the Apocrypha. This step, however, failed to satisfy all the supporters of the society in Scotland, who proceeded to form themselves into independent associations. A third serious controversy by which the society has been agitated, was occasioned by the alleged inaccuracy of some of the translations issued under its authority; and a fourth referred to the admissibility of non-Trinitarians to the privilege of co-operation. The refusal of the society in 1831 to alter its constitution so as formally to exclude such persons, led to the formation of the Trinitarian Bible Society. This has, however, been exceedingly limited in its operations, and the original society stands unrivalled.

By a law of the British and Foreign Bible Society, no translations are adopted or circulated in the languages of the United Kingdom except the Authorized Version. For other countries the best ancient

or received versions are printed; and in the case of new translations, every effort is made to ascertain their strict fidelity and general literary merit. Most of the versions for countries not yet enlightened by Christianity are made by resident missionaries; and these the society prints at the instance of the missionary societies for whose use they are chiefly intended. These versions are made, wherever practicable, from the original Hebrew or Greek text. The society has had a share, direct or indirect, in the translation, printing, or distribution of Scriptures in 210 languages or dialects, the number of versions thus printed being 289. Altogether the society has put into circulation nearly 74 million Bibles, Testaments, and Portions (i.e., single books of the Bible); and its expenditure for this purpose has amounted to £7,750,000.

In the course of 1874 there were issued from the society's depôts, at home and abroad, no fewer than 2,819,427 Bibles, Testaments, and Portions. The free income for 1874-5 amounted to £119,093, 7s. 7d.; adding the contributions for special objects, and the proceeds by sale of Scriptures, a total is reached of £222,191, 5s. 6d. The payments for translating, printing, and circulating the Scriptures were only £691 in the first year of the society's existence; while in 1874-75 they were £217,890, 13s. 1d.

Immediately after the foundation of the society an extensive correspondence was opened with ministers and laymen in all parts of the world.

*Auxiliary and Branch Societies* were gradually formed in every district of the United Kingdom and in the colonies. These became centres whence the Scriptures might be obtained at cost price, and in cases of special need at even less. There are at present in the United Kingdom 4496 auxiliaries and branches, besides 1208 in the British colonies. Many of these are managed by ladies. Juvenile associations have also been organized in many localities.

*Agents* have been appointed both at home and abroad to investigate local requirements, to supply information for the guidance of the committee, and to suggest the best means of carrying out the great purpose of the society.

*Depôts* for the sale of Scriptures have likewise been opened in almost every town of England, and in many places abroad.

*Colportage* is employed to some extent in England, and very largely on the Continent and in India.

*Grants to Societies* are made on various conditions. When applied for by missionary societies and philanthropic institutions, copies of the Scriptures are supplied very freely; while grants of money and paper are made to other societies in aid of the translation and printing of the Scriptures, when good reasons are seen for the expenditure.

It may be added that the society does not encourage the *gratuitous* distribution of Bibles and Testaments, except under peculiar circumstances.

The first English New Testament printed by the society was issued in September 1805. Stereotype printing had just been introduced; and this invention, coupled with the society's plan of selling the Scriptures at a very low price, brought about a speedy and general reduction in the price of English Bibles. Besides this indirect benefit which has thus been secured to English readers, the investigations and exertions of the society first revealed, and then relieved, the great scarcity of Bibles which had previously existed. To show what the deficiency was, it may be mentioned that in 1812 inquiry was made into the case of 17,000 families in the metropolis, when it was discovered that half of them did not possess a Bible at all.

The efforts of the society in India are organized upon a scale and with a completeness scarcely rivalled elsewhere. Bible circulation in India owes its origin mainly to the zeal of the Serampore missionaries, especially of Carey, Marshman, and Ward, whose labours had begun shortly before the Bible Society was formed. It was stimulated by the exertions of Dr Claudius Buchanan, and by the establishment of the college at Fort William. Gradually auxiliary societies were formed at important centres—such as Calcutta, Bombay, Madras, Allahabad, &c. One of these auxiliaries alone—that at Madras—circulated in 1874-75 over 120,000 copies, and employed 55 native colporteurs. The assistance afforded by the society to India and Ceylon in grants of money, paper, and books—including £27,230 supplied to Dr Carey and his associates—amounts to no less a sum than £261,193.

When the society began to inquire into the state of the Continent, the dearth of Scriptures was found to be greater, if possible, than at home. Thus, in Lithuania, among 18,000 Germans, 7800 Polish, and 7000 Lithuanian families, not a Bible was to be found. One half of the population of Holland appeared to be without the Scriptures. In Poland a Bible could hardly be obtained at any price. In the district of Dorpat (Esthonia), containing 106,000 inhabitants, not 200 Testaments were to be found, and there were Christian pastors who did not possess the Scriptures in the dialect in which they preached. Into Iceland, with a population of 50,000, of whom almost all could read, not above 40 or 50 copies had penetrated; while in Sweden a single auxiliary found 18,900 families totally unprovided.

Such was the state of things abroad when the society was established. Correspondence was at once opened with well-known men like Oberlin, Knapp, and Herzog; the society's foreign secretary and agents personally visited the districts, and various subsidiary societies were formed. The highest patronage was often obtained for these, the emperor of Russia, the kings of Prussia, Bavaria, Sweden, and Württemberg, and many others, entering heartily into the work. Some of the societies thus formed were, however, suppressed through the influence of Rome. More than 15,000,000 copies have been printed by them up to the present time.

Of all the foreign Bible societies, by far the most remarkable was that established in Russia, in the year 1813, under the presidency of Prince Galitzin, and with the direct approval and support of the Emperor Alexander I. An imperial ukase was issued, giving formal sanction to the project; all communities joined to speed it on its way; 289 auxiliaries were rapidly formed; the Scriptures were printed in nearly 80 languages, including Modern Russ; 861,000 copies were circulated; and at the time of its suspension in 1826 it had been aided by the British and Foreign Bible Society to the extent of 216,838.

Besides thus encouraging Bible circulation through friendly counsel and pecuniary aid, the British and Foreign Bible Society has done and is doing a direct work on the Continent, some illustration of which may be gathered from the following particulars:—

The first French Bible printed by the society was prepared for the prisoners of war in 1805. After the peace was concluded, measures were taken to form centres of Bible circulation through the country. As a result of these movements, various Bible societies sprang up. Dépôts have also been opened in Paris and many other large towns; and special provision has been made for the provincials of the west, by the preparation of Basque and Breton versions. There have been printed by the society, in the French tongue, upwards of seven and a half million copies of the Scriptures.

In 1835, when Mr W. P. Tiddy went out as agent for the society in Belgium, hardly a Bible was to be found in the country, and evangelistic efforts were rare, through the vehement opposition which they encountered. A staff of colporteurs was appointed, and through their efforts a large supply of Scriptures was distributed. This led to the formation of several Protestant communities.

The society's agent in Germany superintends the movements of between 60 and 70 colporteurs, and reports a yearly circulation of about 300,000 copies. The services rendered during the Franco-Prussian war were so signal as to call forth not only the grateful appreciation of the Germans, but a written acknowledgment from the emperor, who is himself an annual subscriber to the society.

Efforts were made by Dr Pinkerton in 1816 to establish a National Bible Society for Austria; but through the influence of the Pope the emperor was induced to reject the proposal. A new beginning was made in 1850, when in less than two years 41,659 copies of the Scriptures, in German, Bohemian, and Hungarian, were put into circulation. Fresh opposition was, however, soon awakened, and the authorities ordered the whole stock on hand to be withdrawn from the country. In compliance with this order, Mr E. Millard, the society's agent, retired to Prussia, where he laboured for several years with marked success. After a while he was permitted to return to Vienna, and to open dépôts at such centres as Pesth, Trieste, Klagenburg, and Prag. By these means, and through a large staff of colporteurs, he has issued during the past ten years 1,250,000 copies.

Very little direct work was done in Italy until the Revolution of 1848. Then the society gladly hailed the opportunity of entering the country; but soon the door was again closed. The Pope issued an encyclical in 1849, in which the condemnation of Bible societies was emphatically repeated. As a consequence, 2000 New Testaments, just printed at Florence, were seized, presses were confiscated, paper and type carried off, and the society's agent compelled to retire. All this is now altered. The headquarters of the society's Italian agency are at Rome, and the Scriptures are distributed from dépôts and by colporteurs in all parts of the peninsula.

Little could be done in Spain prior to the Revolution of 1808, which threw open the country and established religious liberty. All available means were then adopted for printing and circulating the Spanish Bible. The issues from the Madrid dépôt have exceeded half a million copies, but during the recent civil troubles the movements of the colporteurs have been much restricted.

Between 300,000 and 400,000 copies of the Scriptures have been printed in the Portuguese tongue.

Mr Paterson paid a visit to Sweden in 1809 on behalf of the society, and found the poor almost entirely without the Scriptures. Thus in one diocese 10,000 families were discovered without a Bible in their possession. An agency was established in 1831. Special grants have been made to the army and navy, and for the students in the universities. The total issues since 1832 have been over 2,000,000, and that in a population of less than 4,000,000.

To give even an outline of the work done by the British and Foreign Bible Society in the more remote parts of the world would be to write a volume. All the great missionary societies are its

debtors. Its undenominational character has secured what could hardly otherwise have been attained—the use of the same version by missionaries of different churches; and it has often proved a healer and a peace-maker abroad, while it has been a bond of union at home. To the linguist and to the comparative philologist its operations are of intense interest; and the boon conferred on the thought and language of many nations through its versions of the Scriptures is well-nigh inestimable.

The EDINBURGH BIBLE SOCIETY originated in the controversy respecting the circulation of the Apocrypha, and was composed of Protestants professing their belief in the doctrine of the Holy Trinity, and disposed to co-operate in promoting the dissemination of the Scriptures.

The SCOTTISH BIBLE SOCIETY was instituted upwards of forty years ago. At the time of its establishment, the other Bible societies in Scotland employed their funds chiefly in circulating the Scriptures in foreign countries. This association was intended exclusively for the distribution of the Bible at home, and its funds were at first derived from collections made in the parish churches within the Synod of Lothian and Tweeddale.

The Scotch Bible societies were amalgamated in 1861, and took the name of the NATIONAL BIBLE SOCIETY OF SCOTLAND. During the year 1874 the society issued 340,908 Bibles, Testaments, and "Portions," its receipts, including the proceeds of sales, amounting to £26,840.

The first Bible society in America is believed to have been established by a few Baptists in New York in 1804; its object was to purchase and lend Bibles for a month at a time. The PHILADELPHIA BIBLE SOCIETY, which was instituted December 12, 1808, was for some years the only association in the country for the gratuitous distribution of the sacred Scriptures. The AMERICAN BIBLE SOCIETY was formed at New York, May 8, 1817. It has numerous auxiliaries throughout the several states of the Union. In 1875 its income amounted to \$577,569. Its issues during that year were 926,900 Bibles and Testaments, and since its formation 31,893,332.

Among other societies may be mentioned the BIBLE TRANSLATION SOCIETY, whose versions embody the views of the Baptists, and the PORTUGUESE BIBLE SOCIETY (named from Bishop Porteus), for the circulation of Bibles marked so as to show the practical bearing of each chapter.

It is believed that there are altogether about 70 Bible societies in the world. The issues of the 7 leading societies may be summarized as follows:—

The British and Foreign Bible Society.....	73,750,533
The American Bible Society.....	31,893,332
The National Bible Society of Scotland.....	4,563,669
The Prussian Bible Society at Berlin.....	4,058,413
The Hibernian Bible Society.....	3,962,581
The Württemberg Bible Society.....	1,279,966
The Netherlands Bible Society.....	1,253,643

Total..... 120,792,143

The monopoly of the right to print the Bible in England is still possessed by the Universities of Oxford and Cambridge, and her Majesty's printer for England. But after a controversy, which was carried on for some time with great warmth (1840–41), the prices of the common Bibles and Testaments were greatly reduced, and they have gradually attained their present remarkable cheapness.

In Scotland, on the expiry of the monopoly in 1839, Parliament refused to renew the patent, and appointed a Bible Board for Scotland, with power to grant licences to print the Authorized Version of the Scriptures. This step produced a great reduction in the price of the sacred volume, and its circulation was considerably increased.

See Owen's *History of the First Ten Years of the British and Foreign Bible Society*; *Bible Triumphs, a Jubilee Memorial for the British and Foreign Bible Society*; Brown's *History of the Bible Society*, 1859. (M. A. C.)

## BIBLIOGRAPHY

THE term Bibliography has passed through different meanings. The βιβλιογράφος of the Greeks, like the *librarius* of the Romans, was a mere copyist. When the name *bibliographia* was adopted by the French, it was used, as late as the middle of the last century, to signify skill in deciphering and judging of ancient manuscripts. Its special application to printed books may be said to date from the *Bibliographie Instructive* of De Bure in 1763; not that he appears to have coined the new meaning of the term, but his work first popularized the study which the growth of libraries and the commerce in literature had created.

Bibliography, thus understood, may be defined as the science of books, having regard to their description and proper classification. Viewing books simply as vehicles of learning, it would undoubtedly be correct to extend our inquiry to the period when the only books, so called, were manuscripts. And such is, in fact, the view adopted by bibliographers like Peignot, Namur, and Hartwell Horna. But a survey so extensive is open to practical objections. In the first place, bibliography as a science was unknown until long after printing had laid its first foundations, and indeed made it a necessity, with requirements increasing with the multiplied productions of the press. The materials for comparative study were wanting in an age when books were regarded as isolated treasures, to be bought at prices corresponding with their scarcity. In the second place, the critical study and comparison of ancient manuscripts, their distribution into families deduced from one or more archetypes, and the investigation of ancient systems of writing, embrace a subject so wide in its scope and special in its character, that convenience of treatment, confirmed as it is by the facts of history, would alone suggest the propriety of distinguishing between manuscript and printed bibliography. This distinction it is here proposed to observe, the subject of MSS. being reserved for the article PALÆOGRAPHY, the name which in its maturity it received.

Amid much variety of treatment in detail, two main divisions underlie the general study of bibliography, viz., *material* and *literary*, according as books are regarded with reference to their form or their substance. The former belongs chiefly to the bookseller and book-collector; the latter to the literary man and the scholar. Material bibliography treats of what Savigny terms the "äussere Bücherwesen," or the external characteristics of books, their forms, prices and rarity, the names of the printers, the date and place of publication, and the history of particular copies or editions. It involves a knowledge of typography, not, indeed, as a mechanical process, but in its results, and, in fact, of all the constituent part of books, as a means of identifying particular productions. Its full development is due to the gradual formation of a technical science of books. Considerations of buying and selling, which were first reduced to a system in Holland, and afterwards advanced to their present complete form in France and England, gave an impetus to this branch of bibliography. The growth of private libraries, especially during the last century in France, promoted a passion among rich amateurs for rare and curious books; and literary antiquarians began to study those extrinsic circumstances, apart from the merit of their contents, which went to determine their marketable value, and to reveal the elements of rarity.

Literary, or, as it is sometimes called, intellectual bibliography treats of books by their contents, and of their connection in a literary point of view. It has been subdivided into *pure* and *applied*, according as its functions

became more complex with the spread of printed books and the increasing requirements of learning. Catalogues expanded into dictionaries, whose object was to acquaint literary men with the most important works in every branch of learning. Books were accordingly classified by their contents, and the compiler had to distinguish between degrees of relative utility, so that students might know what books to select. This duty, which devolved in most cases on men of learning, has led French writers in particular to exaggerate the province of bibliography. "La bibliographie," says Achard, "étant la plus étendue de toutes les sciences, semble devoir les renfermer toutes;" and Peignot describes it under his proposed title of *Bibliologie*, as "la plus vaste et la plus universelle de toutes les connaissances humaines." We know of no excuse for such pretensions beyond this, that books represent, in its transmissible form, the sum total of all kinds of knowledge. The bibliographer has to determine the genuineness, not the authenticity of a book; its identity of authorship or publication, not the correctness of its contents. When he pronounces judgment on its intrinsic merits he usurps the office of the critic. Some works, indeed,—like Baillet's *Jugemens des Savans, sur les Principaux Ouvrages des Auteurs*, augmentés par M. de la Monnoye, 8 vols., Amst., 1724; Blount's *Censura Celebriorum Auctorum*, London, 1690; Morhof's *Polihistor Literarius, Philosophicus, et Practicus*, the best edition of which is that of Fabricius in 1747; the *Onomasticon Literarium* of Saxius, Utrecht, 7 vols., 1769-90; and the *Censura Literaria* of Sir Egerton Brydges, 10 vols., 1805-9,—are collections of critical bibliography of extreme value to the literary historian; but there is a wide difference in design between compilations even of this kind and works devoted to original criticism. In like manner the proper objects of classification have been neglected by many bibliographers, who have indulged in refinements of method, not as a means of facilitating reference, but for the purpose of illustrating a philosophical system of learning. Pretensions such as these, have, unfortunately, done much to discredit bibliography as a science of practical application, by investing it with a false air of mystery, and exposing it to the charge of empiricism. Its real value, in a literary aspect, depends on the recognition of its purpose as ancillary to the study of literature; not, in short, as an end, but as a means to the attainment of knowledge, by the investigation of its sources.

France must be regarded as the real mother of bibliography.<sup>1</sup> Italy was the field in which book-collections first began on a large scale, and that country can boast of names like Magliabecchi, Apostolo Zeno, Bandini, Audiffredi, Mazuchelli, and Morelli, besides provincial works like Moreni's *Bibliografia della Toscana*, and Gamba's *Serie di Testi*. But the labours of French bibliographers, especially after Naudé, converted a study, more or less desultory, into a science and a systematic pursuit. In Germany, poor in public and almost destitute of private libraries, bibliography has been studied almost exclusively in its literary aspect. Belgium has shown much recent activity; but neither Holland, Spain, nor Portugal can show any modern work of importance. In England the paucity of bibliographers is the more to be regretted from the wealth of her resources. Richard de Bury, in his *Philobiblion*, had descanted on the charms of book-collecting as early as the 14th century; but Blount's *Censura*, published in 1690, was the only regular

<sup>1</sup> The term *biblioposte* originated with the Abbé Bive; words similarly compounded, and involving fanciful notions of distinction, are common among French writers on this subject (Peignot).

treatise on bibliography up to that date. Oldys, whose *British Librarian* first appeared in 1737 but was never completed, was among the first in this country to divert the public taste from an exclusive attention to new books, by making the merit of old ones the subject of critical discussion; and Maittaire, who was second master of Westminster School, and who died in 1747, first established the study of bibliography in England on a solid basis. The labours of Dibdin we shall have occasion frequently to refer to; they mark a new phase of bibliography in England which followed the opening up of the Continent after the great war with France. The science in America has been cultivated only recently; but the names of Cogswell, Ticknor, and Jewett are already well-known to bibliographers.

### I *The Constituent Parts of Books, and Differences of Editions.*

The history of the materials used for early manuscripts—a subject fruitful in research—lies outside the limits we have proposed for bibliography as the study of printed literature. Fortunately for the spread of books, in the modern sense of the term, the invention of printing was preceded by the important discovery of the art of making paper from linen rags. The precise date of this discovery is not known, nor are writers agreed as to the country in which it was made; but it seems to be ascertained that this kind of paper was in general use in Europe before the end of the 14th century. Caxton and the other early English printers appear to have used paper of foreign manufacture. Such questions, among others, as the relative priority of different editions, or the productions of different presses, are frequently to be determined by a comparison of the constituent elements of the books themselves; but the subject is too technical to be noticed in detail. The question as to the origin of printing belongs strictly to a consideration of that art; but as its history and its progress are illustrated by the productions of different presses, the bibliographer will find much matter of interest in the principal works devoted to the subject. Prominent among these are the *Monumenta Typographica* of Wolfius, Hamburg, 1740; Meerman's *Origines Typographica*; Prosper Marchand's *Histoire de l'origine et des premiers progrès de l'Imprimerie*, 1740,—a valuable supplement to which was published by M. Mercier, Abbé de Saint Leger, in 1773, and republished in 1775; and Lambinet's *Recherches historiques, littéraires, et critiques sur l'origine de l'Imprimerie*, first published at Brussels in 1799.

An accurate knowledge of the different forms of books is necessary to the bibliographer, as without it no book can be correctly described; and however easy such knowledge may appear, it is yet certain that errors in this respect have been committed even by experienced bibliographers, and that doubts have been entertained as to the existence of editions, owing to their forms having been inaccurately described.<sup>1</sup> These mistakes generally proceed from this, that there are different sizes of paper comprehended under the same name. But the water-lines in the sheets afford a test, as they are uniformly perpendicular in the folio and octavo, and horizontal in the quarto and duodecimo sizes. In the infancy of printing the sizes were generally folio and quarto, and some have supposed that no books were printed in the smaller forms till after 1480; but M. Peignot instances many editions in the smallest forms of an earlier date; as may be seen in the article "Format" of the supplement to his *Dictionnaire de Bibliologie*. The subject of water-marks is treated at length in Sotheby's *Principia Typographica*.

<sup>1</sup> See Bouard, *Traité Élémentaire de Bibliologie*, pp. 33, 39.

The respective merits of different editions can be ascertained often only by minute inquiries. It is a principal object of the bibliographical dictionaries, to be afterwards mentioned, to point out those editions of important works which such inquiries have discovered to be the best. There are many particulars in which one edition may differ from or excel another. There may be differences or grounds of preference in size, in paper, and in printing. Later revision by the author may give his work, when it comes to be reprinted, a complexion differing largely from what it had at the first; while the first edition exhibits his original thoughts as they came fresh from his pen. One edition may derive its superiority from being furnished with notes, an index, or a table of contents. Plates make great differences in the value of editions, and even in the value of copies of the same edition. In the beautifully engraved edition of *Horace* by Pine, a small error in the first impressions serves as a test whether any copy contains the best engravings of those elegant vignettes which illustrate that edition. The medal of Augustus, on page 108 of the second volume, has in the first copies the incorrect reading *Post Est* instead of *Potest*; this was rectified in the after impressions; but as the plates had meanwhile sustained some injury, the copies which show the incorrect reading are of course esteemed the best. Dibdin, in his *Bibliomania*, points out this as an instance of preference founded on a defect; but the real ground of preference is the superiority of the impressions, ascertained by the presence of this trifling defect. There are sometimes differences between copies of the same edition of a work.<sup>2</sup> Walton's *Polyglot Bible* is a celebrated instance. The printing of that great work, for which Cromwell liberally allowed paper to be imported free of duty, was begun in 1653 and completed in 1657, and the preface to it in some copies contains a respectful acknowledgement of this piece of patronage on the part of the Protector; but in other copies the compliment is expunged, and replaced by some invectives against the republicans.—Walton having on the Restoration printed another preface to the copies which had not by that time been disposed of.<sup>3</sup>

### II *Early Printed Books.*

The first productions to which the name of *Books* has been applied, were printed, not with movable types, but from solid wooden blocks. These consisted of a few leaves only, on which were impressed images of saints and other historical pictures, with a text or a few explanatory lines. The ink was of a brownish hue, and glutinous quality, to prevent it from spreading. These are known by the name of *Image Books*, or *Block Books*, and are generally supposed to have succeeded the earlier impressions for playing cards, which are dated back to the end of the 14th century. Strictly speaking, they were the immediate precursors, rather than the first specimens of typography; in fact, they mark the transition to that art from engraving.<sup>4</sup> Peignot puts their number at seven or eight, but others have extended it to ten. They belong chiefly to the Low Countries, and were often reprinted, as is generally thought, during the first half of the 15th century, and, indeed, after

<sup>2</sup> The *Voyage to Cadix* is sometimes wanting in Hakluyt's *Navigations*, 1598-1600. A reprint is often inserted to supply this want, which may be known from the original by its having only seven paragraphs in p. 607, vol. i., whereas the original has eight. The original ends on p. 619, the reprint on p. 620.

<sup>3</sup> See vol. i. of Dr Clarke's *Bibliographical Dictionary* for some curious details on this point.

<sup>4</sup> Mr Holt, who contends that printing preceded engraving, assigns the date of 1423 on the *St. Christopher* to a forgery for 1483, and asserts that no copy of the *Biblia Pauperum* was known before 1486. See *Notes and Queries*, 4th series, II. 265.

the discovery of printing, properly so called. One of the most celebrated is the *Biblia Pauperum*,<sup>1</sup> consisting of forty leaves, printed on one side, so as to make twenty when pasted together, on which passages from Scripture are represented by means of figures, with inscriptions. It appears to have been originally intended for the use of those poor persons who could not afford to buy complete copies of the Bible. Some fugitive sheets still attest the primitive attempts at printing, in the modern sense of the word. *The Letters of Indulgence* of Pope Nicholas V., two editions of which, on a small sheet of parchment, were printed in 1454, fix the earliest period of the impression of metal types, with a date subjoined.<sup>2</sup> The earliest known book, however, of any magnitude, and probably the first thus printed, was the undated *editio princeps* of the Bible, commonly known as the Mazarin Bible, from a copy having been found by De Bure in the library of the Cardinal. It is undated, but authorities generally concur in ascribing it to a period between 1450 and 1455. The work is usually divided into two volumes, the first containing 324, and the second 317 pages, each page consisting of two columns. The characters, which are Gothic, are large and handsome, and resemble manuscript. No fewer than twenty copies are known to be extant.<sup>3</sup> The first printed book with a date is the *Psalter* of Fust and Schöffer, printed at Mentz in 1457, as a somewhat pompous colophon announces. It was found, in 1665, in the Castle of Ambras, near Innsbruck, where the Archduke Francis Sigismund had collected a quantity of MSS. and printed books, taken chiefly from the library of Corvinus. A few other copies are in existence, one of which was bought under Louis XVIII. for the Royal Library at Paris for the sum of 12,000 francs. Whether the types employed were wooden or metallic has been disputed between Van Praet and Didot. As a specimen of early printing the work is magnificent; it contains richly embellished capitals in blue, red, and purple.

Besides these monuments of infant typography, a special interest attaches to the productions of the 15th century. They are usually known as *Incunabula*, a term applied to them by modern German writers. Brunet, following Santander, estimates their number at 18,000 or 20,000; but it is probable that many duplicates are included in this reckoning. They came into demand chiefly at the beginning of the last century, and especially about 1740, at the third centenary of printing. The passion for them at first was indiscriminate, but preference afterwards was given to the presses of Mayence, Bamberg, Cologne, Strasburg, Rome, and Venice.

As regards these early printed books, a knowledge of typography is necessary to the bibliographer, to enable him to verify their identity. A brief reference to some of their leading peculiarities must suffice here. The printer's name,

<sup>1</sup> So called first by Heineken, *Idæ generalis d' une collection complete d' Estampes*, 8vo., 1771. Dibdin, in his *Bibl. Spenseriana*, and Otley, in his *History of Engraving*, have given fac-similes of the figures in several of the block-books. See also Falkenstein's *Geschichte der Buchdruckerkunst in ihrer Entstehung und Ausbildung*, 4to., 1840; Schellhorn's *Asson. Lit.*; the works of Maittaire, D. Clement, Fournier, Meermann, Papillon, and De Bure; and J. P. Berjean's *Catalogue illustré des livres xylographiques*, 1865. Heineken was the chief authority until recently, when his views, especially on the chronology of the block-books, have been much contested. Sotheby's *Principia Typographica*, 3 vols., 1858, is the most important work on this subject in late years. The author has also attempted to elucidate the character of the water-marks of the period.

<sup>2</sup> Dibdin's *Bibl. Spenser.*, i. xlvii.

<sup>3</sup> Before the discovery of the Mazarin Bible, the Bamberg Bible of Pfister generally passed for the first printed book. Schellhorn has written a treatise maintaining its priority of age. As to the Mazarin Bible, see an article by Dibdin in Valpy's *Classical Journal*, No. 8. The kind of types employed upon it has been the subject of much dispute.

and the date<sup>4</sup> and place of printing<sup>5</sup> were at first omitted, the printer imitating the reticence of the copyist, and the book being a mere fac-simile of the manuscript. In Germany and the Low Countries few dated books are found before 1476 or 1480. Title-pages appear to have come in a few years later; none of Caxton's works, with one doubtful exception, have any. Titles to chapters were first used in the *Epistles of Cicero*, 1470. According to Palmer, the use of signatures, or letters at the bottom of the page to guide the bookbinder in the arrangement of the sheets, began with Zarot in a Terence printed by him at Milan in 1470. Marolles ascribes them to John of Cologne, who printed at Venice in 1474, and the Abbé Rive to John Koelhof, a printer of Cologne. They were in use in that city in 1475, and at Paris the next year, but were not employed by Caxton until 1480. Catch-words, which, like signatures, preceded the numbering of pages, are found in MSS. of the 11th century, and were first applied to printing by Vindelino de Spira at Venice. Their purpose, to direct the binder, had been previously supplied by *Registers*, or alphabetical tables of the first word of chapters, which were introduced about 1469. The earliest system of numbering was applied, not to pages, but to leaves, a large Roman figure being placed at the top of the *recto* in each leaf. The characters were uniformly Gothic—the foundation of our Black-letter—until 1467, when Gothic was supplanted by the Roman type, introduced in that year at Rome, and improved on by Jenson at Venice. It was first used in England by Pynson. *Italics* were first used by Aldus in his *Virgil* of 1501; they are said to have been suggested to him by Petrarch's writing, and were employed to compress matter into his small octavos without the inconvenience of abbreviations. Hebrew characters began at Soncino, in the duchy of Milan, in 1482, and at Naples in 1487. The only points first used were the colon and full stop; but Aldus improved punctuation by giving a better shape to the comma and adding the semicolon. With Caxton oblique strokes took the place of commas and periods. The form of the earliest books was chiefly folio and quarto. Almost every page abounded in abbreviations or contractions. Blank spaces were left for capitals and the first letters of periods, which were afterwards filled up by the illuminator. The Basel press was noted for its ornamental initials; and Calliergus at Rome and the Paris printers excelled in decorative printing of this kind. The taste for embellishment led to ornamental title-pages about 1490, the usual ornament at first being the "author at his desk." The custom of coloured frontispieces appears to have prevailed until the end of last century. Decorated borders appear in the first page of some of Sweynheim and Pannartz's productions; few ornaments, however, were introduced into the body of the text before the first Hebrew publications.<sup>6</sup> The *Aulus Gellius* of 1469 by the same printers is cited as the first book with a preface; and their *Apuleius* of the same year contains the earliest marginal notes. For further information on the characteristics of early printed books the reader will do well to consult Palmer's *General History of Printing* (a work ascribed chiefly to George Paumanazar); Jungendres, *De Notis Characteristicis Librorum a Typographia Incunabulis ad annum 1500 impressorum*; and Marolles's *Recherches sur l'Origine des Signatures et des Chiffres de Page*.

<sup>4</sup> The date was sometimes computed by Olympiads, as in the *Assonii Epigrammata*, printed at Venice in 1472. Middleton, who has written to prove that the Oxford *Expositio S. Jeronimi* of 1468 contains a falsified date, quotes, as an example, the *Decor Psalterium* of Jenson, at Venice, which is dated 1461, instead of 1471, in order, he says, to give priority to the printer over John de Spira, whose first work appeared in 1469 (*Works*, iii. 236).

<sup>5</sup> For this class of books see De Roset's *Annales Hebraeo-Typographicae*, 1795-99.

The devices of the early printers are of importance to the bibliographer, since questions occur as to the early editions which can only be ascertained by discovering the printer's name. The invention of marks or vignettes is ascribed by Laire (*Index Librorum Sæc. XV.*, ii. 146) to Aldus; he traces them to a Greek Psalter of 1495. A device, however, consisting of two shields occurs in Fust and Schöffer's Bible of 1462. They were not used by Ulric Zell, the first printer at Cologne, nor by the fathers of the Paris or Venetian presses. Monograms or ciphers were frequently employed, with initial letters of names or other devices curiously interwoven, and these furnish a trustworthy clue to identity. The monograms of the Early English printers are explained in Ames's *Typographical Antiquities*. Of the devices of different presses the best fac-similes are given in Dibdin's *Bibliographical Decameron*, vol. ii. Orlandi's *Origine e Progressi della Stampa*, Bologna, 4to, 1722, is a work of indifferent merit. The *Thesaurus Symbolorum ac Emblematum* of Scholtz, published at Nuremberg in 1730, and Spoerlius's *Introductio in Notitiam insignium Typographorum*, of the same year, are the best and most interesting authorities on this subject.

The *incunabula* of the various early presses have been treated separately by different writers. Schwarz in 1740 and Wurdwein in 1787 reviewed the productions of the Mentz press. Those of Nuremberg were noticed by Röder in 1742; and a catalogue of them, in the library of that town, was compiled by Saubert in 1643. In Italy, the Roman press is represented by Michael Canensio in 1740, and more particularly by Audiffredi in 1783, who afterwards extended his researches to all early Italian productions. The books issued from Milan between 1465 and 1500 have been noticed by Saxius; the Parmese editions by Affo in 1791; those of the Spiras at Venice by Pellegrini in 1794; those of Friuli by Bartolini in 1798; and those of Ferrara by Antonelli in 1830. The early Paris press has been copiously treated by Chevillier, and that of Lyons by Péricaud, 1840. For Spain there is Caballero in 1793; and the works printed in the Low Countries are reviewed at length in Meermann's *Uitvinding den Boekdrukkonst*, Amsterdam, 1767. Herbert, Ames, and Dibdin well-nigh exhaust the subject of early English bibliography. The different collections of *incunabula* in public or private libraries have been noticed in more or less detail. Seemiller in 1785 catalogued upwards of 1800 editions of the 15th century at Ingolstadt. Those in the Magliabecchian library at Florence have been described by Fossi (or rather Follini) in 1793-95. The collection of Lomenie de Brienne is known through the labours of the elder De Bure and his continuator, Laire; and the treasures of Count Boutourlin were catalogued by Audin de Rians. Lambeth library contains many specimens, which have been noticed by Maitland; and the splendid collection of Earl Spencer at Althorp has met with a worthy exponent in Dibdin.<sup>1</sup>

For more general information on this subject the reader may consult the following works:—*Index Librorum ab inventa Typographia ad annum 1500, cum notis*, 2 vols. 1791. This work, by Laire, is one of the most useful of its kind, and it has the advantage of four indexes, which furnish a ready reference to its contents. De Bure, in the seventh volume of his *Bibliographie Instructive*, has given a list of 15th century books, classed in the order of the different towns. M. La Serna Santander's *Dictionnaire Bibliographique choisi du quinzième siècle*, 3 vols., 1805, is a very learned and exact work, and, like Laire's *Index* above mentioned, embraces only the rarest and most interesting publications of the 15th century. See also the *Lettres de l'Abbé de St. L.* (Mercier de St.

Leger), ou Baron de H. (Hahn), Paris, 1785. Maittaire's *Annales Typographici ab arte inventa origine* is a mine of learning and research. The first volume, published in 1719, embraces the period from the origin of printing to 1500, but his researches into printed literature extended in the third volume to 1657; and there is an appendix which affords a partial continuation to 1684. A supplement to this elaborate work, by Denis, in 2 vols. 4to, appeared at Vienna in 1789, and contains 6811 articles omitted by Maittaire. Panzer's *Annales Typographici* was founded on the preceding work, and consisted of eleven volumes, which were published at Nuremberg between 1793 and 1803. It was intended to be limited to the 15th century, but, after the appearance of the fifth volume, the period was extended to the year 1836. German publications were reserved for a separate work, which bears the title of *Annales der älteren deutschen Literatur*. The *Repertorium Bibliographicum* of Lud. Hain, 4 vols. 1828-38, contains an alphabetical list of no less than 16,299 books printed during the 15th century, which are described with rare minuteness and accuracy. The author's labours were terminated by death, when he had advanced as far as U. The addition of bibliographical notices, pointing out first editions and books of remarkable rarity and price, would have much enhanced its interest and value. The *Littérature d. ersten 100 Jahre nach d. Erfindung d. Typographie*, by Chr. F. Harless, was published at Leipzig in 1840. Its object differs from that of the preceding works, in making the notice of early editions subordinate to his purpose of illustrating thereby the transition and progress of contemporary learning.

### III. Rare and Curious Books.

This branch of what Ebert terms "restricted" bibliography belongs peculiarly to the book-collector and bookseller, if regard be had especially to the inclinations of purchasers, the actual demand, and the marketable value of books. Rarity and price depend very much on each other; rarity makes them dear, and dearer makes them rare. Hallam asserts that the price of books was reduced four-fifths by the inventing of printing. From a letter of Andreas, bishop of Aleria, to the pope, in his preface to the *Epistles of Jerome*, it would seem that 100 golden crowns was the maximum demanded for a valuable MS., and that the first printed books were sold for about 4 golden crowns a volume. At any rate, one natural effect of printing was to restrict the number of rare books to a separate class. Cailleau, who has been followed by most other writers on this subject, distinguishes between *absolute* and *relative* rarity. The former term is applied to those books or editions of which only a small number has been printed. Such for the most part are works printed for private circulation, as those of the Strawberry Hill Press, which are very scarce and enormously dear. This class of English books is treated in the *Bibliographical Catalogue of Books, privately printed*, by John Martin, 1834, republished, with additions, in 1854, 8vo. Much of the value attached to editions of the 15th century arises from the limited number of impressions. They were seldom more than 300; John of Spira printed only 100 copies of his *Pliny* and *Cicero*; and printers had the example of Sweyheim and Pannartz, who were reduced to poverty by their surplus copies, to avoid exceeding the current demand. Suppressed works belong to the same category, in proportion to the success of prohibition. Others owe their scarcity to accidental destruction; as, for instance, the second volume of Hevelius's *Machina Cœlestis*, 1679, which would have shared the fate of the remainder of his works, on the burning of his house, had the author not previously given some copies to his friends. At the great fire of London in 1666 there were some works of Dugdale, among other writers, as well as the first volume of Trynne's *Records of the Tower*, of which only a few copies escaped; but their value has been reduced by subsequent impressions. The same kind of rarity attaches to *Éditions de luxe*, chiefly made for rich amateurs; to large paper copies and *full copies*, i.e., copies of a work published on paper of ordinary size and barely cut down by the binder; and to books printed on coloured paper. A list of the last-named is given by Duclos and Cailleau, and reprinted by Horne in his

<sup>1</sup> *Bibliotheca Spenceriana*. To this were afterwards added his *Ædes Althorpianæ*, with a supplement, 1822, and the volume on the *Cassino Library*, with a general index, 1823. The beauty of the fac-similes alone would entitle these works to the front rank of books on bibliography.

*Introduction to Bibliography.* It includes an edition of Sterne's *Sentimental Journey*, three copies only of which were printed at Paris in 1803, on rose-coloured paper, and the complete *Works of Voltaire*, edited by Beaumarchais (Kahl, 1788), twenty-five copies of which were struck off on blue paper, after some had been requested by Frederick the Great for his own use, on account of the weakness of his eyesight. Vellum copies, again, have been much prized by collectors. They belong to the early days of printing, especially to the Aldine, Verard, and Giunti presses, and to those of the first English printers. Few were made between the latter half of the 16th and the beginning of the last century; but the art was revived in France by Didot and Bodoni, and the folio *Horses* of 1799 by the former is a *chef d'œuvre* of its kind. The Royal Library at Paris has a sumptuous collection of vellum copies, which have been elaborately described by Van Praet.<sup>1</sup> At the sale of the McCarthy library, the *Pealter* of Fust and Schöffer on vellum was bought by Louis XVIII. for 13,000 francs. The libraries of Earl Spencer and the duke of Devonshire contain the finest specimens in this country. The relative rarity of books is due to a variety of causes, chiefly connected with the peculiar nature of their contents. Among works of this kind, generally speaking, are local histories, lives of learned men, books of antiquities, or of curious arts, those written in languages little known, macaronic treatises, and catalogues of private libraries. Works like the *Acta Sanctorum*, in 53 volumes, however accessible in public though not in private libraries, are rare in this sense of the term. The class of publications known as *Ana*, containing the sayings and doings of men great in their day, has become comparatively scarce. The first of these was the *Scaligerana* of 1666. The public fastened upon them at first with avidity, but the number of such productions created in time a distaste for them (see *ANA*, vol. i., pp. 784-5). Burton's *Anatomy of Melancholy*, which fascinated Dr Johnson, is an instance of undeserved neglect. For a long time it fell into disuse, and from being a waste-paper book, became extremely rare, until reprinted in recent times. Fugitive pieces, like political broadsides, share the penalties of an ephemeral interest. The *King's Pamphlets*, so called from having been presented by George III. to the British Museum, are the largest collection of this kind in England. It owes its origin to the industry of the bookseller Thomason.<sup>2</sup>

In a literary sense, a book, to deserve the title of rare, should be a work of some merit, and not one whose obscurity is due to its worthlessness. Curious books, however, depend very much on the pleasure of the curious; and the follies and caprices of collectors are summed up in the word *Bibliomania*. Some copies of Tuberville's *Book of Hunting*, 1611, were bound in deer-skin; Mr Jeffery, the bookseller, enclosed Mr Fox's historical work in fox-skin; and a story is told of Dr Askew having caused a book to be bound in human skin, for the payment of which he was prosecuted by the binder. German bibliographers reproach us with an undue passion for book curiosities. *Bibliomania* forms the title of an amusing work by Dr Dibdin, who, though accused of a leaning to this weakness, knew well how to value the intelligent study of books. The practice was satirized as early as the time of Brandt,

(see his *Ship of Fools*.) It prevailed in England chiefly during last century, and reached its height at the sale of the duke of Roxburgh's library in 1812.<sup>3</sup> The time, however, has passed away when the passion for collecting rare and curious books, without regard to their usefulness, merit, or beauty, was too often a failing with well-educated persons. The love of uncut and large-paper copies of vellum and first editions, and of illustrated books, has been better regulated since book-madness was attacked by the Abbé Rive, Dibdin, Dr Ferrier, and the Rev. James Beresford; and modern book-clubs like the Roxburghs (1812), the Bannatyne (1823), the Maitland (1823), and the Surtees (1834) Societies, the Abbotsford Club (1834), and the Early English Text Society, have done important service to bibliography by reprinting scarce old books.

Detached notices of rare and curious books are to be found in the catalogues of private libraries, especially those compiled by French writers during the last century. Beloe's *Anecdotes of Literature* contains much interesting matter on scarce books and their prices. The following, however, are the chief works on this subject:—Halervord's *Bibliotheca curiosa*, Frankfurt, 1687; Beyer's *Memoria historico-critica librorum rariorum*, Dresden and Leipzig, 1734; Yogg's *Catalogus historico-criticus librorum rariorum*, the best edition of which appeared at Frankfurt in 1798. The author applies the epithet *rare* with more judgment than his predecessors. A supplement to his work was the *Florilegium historico-criticum librorum rariorum* of Gerdinius, first published in 1740, and again in 1768. The *Bibliotheca curiosa, ou Catalogue raisonné des livres rares et difficiles à trouver*, by D. Clement, Göttingen, 1750-60, is compiled on a more extensive plan than any of the preceding. Although consisting of 9 volumes 4to, it only extends to the letter H, terminating there in consequence of the author's death. Clement is generally blamed for a very profuse and inaccurate application of his own nomenclature; his notes, moreover, are crammed with citations, and tediously minute, but they abound with curious morsels of literary history, and it is to be regretted that the work was not completed. S. Engel, *Bibliotheca Selectissima*, Bern, 8vo, 1748; T. Sinceri, *Notitia historico-critica librorum rariorum*, Frankfurt, 1758; *Bibliographia instructiva, ou Traité de la connoissance des livres rares et singuliers*, by W. F. De Bure, Paris, 1768-68, 7 vols. This work did much to popularize bibliography in France. The author criticizes parts of Clement's dictionary, but recognizes the general merit of that work. De Bure published a supplement in 1769, containing a catalogue of rare and curious books in the library of Gaignat. *Dictionnaire typographique, historique, et critique, des livres rares, estimés, et recherchés en tous genres*, par J. B. L. Osmont, 2 vols. 8vo, Paris, 1768. This work contains a fuller account of Italian books than the preceding. *Dictionnaire bibliographique, historique, et critique, des livres rares, précieux, singuliers, etc.*, by André Charles Caillaud, 3 vols. 8vo, Paris, 1790. This work was compiled, according to M. Barbier and others, by the Abbé Ducloux, and was republished in 1800, with a supplementary volume, by M. Brunet. Notes are affixed to unpriced books, stating their value. *Bibliotheca Librorum rariorum Unicornis*, by Jo. Jac. Bauer, 7 vols. 8vo., 1770-91. Peignot in his *Répertoire des Bibliographies spéciales, curieuses, et instructives*, 8vo, Paris, 1810, has written on the elements of rarity, and the different classes of rare books.

#### IV. The Classics.

Fortunately for the preservation of ancient literature, the discovery of printing coincided very closely with the full development of that zeal for classical learning, which had begun with the 15th century.<sup>4</sup> To Italy belongs the chief glory of first embodying, in an imperishable form, those materials which the industry of Poggio and others had rescued from the dust of monastic libraries. In rapid succession the first editions of the classics issued from Italian presses; no less than fifty of these are enumerated by Panzer. *Apuleius, Aulus Gellius, Cæsar, Livy, Lucan, Virgil*, and portions of *Cicero*, were printed by Sweynheim and Pannartz at Rome before 1470; while the rival press of the Spiras at Venice boasted of *Plautus, Tacitus*,

<sup>1</sup> *Catalogue des livres imprimés sur Velin de la Bibliothèque du Roi*, 1822-28, 6 vols. See his supplemental catalogue of similar books in other libraries, 1824, 4 vols. royal 8vo. Panzer, as he informs us in his *Essai sur l'Histoire du Paroëme et du Velin*, 1812, intended, but did not execute, a comprehensive work on vellum curiosities. See also Schellhorn's *Asiam. Littér.*, vol. 1.

<sup>2</sup> See Oldys's *Dissertation on Pamphlets*, and the *Icon Libellorum* of Myles Davis, a résumé of which is given in Darsall's *Amusements of Literature*. Aungerville de Bury admitted *Pamphlets exigus* into his library.

<sup>3</sup> At this sale the Valdarfer Boccaccio of 1471 fell to the Marquis of Bradford, after a spirited competition with Earl Spencer, for £2260.

<sup>4</sup> Hallam's *Lit. of Europe*, l. 146; Roscoe's *Lorenzo de Medicis*.

*Priscian, Sallust, Catullus, Tibullus, and Propertius.* From Brescia came *Lucretius*, from Vicenza, *Claudian*; Ferrara and Naples gave birth to *Martial* and *Seneca*. In Germany, France, and the Low Countries, on the other hand, the progress at first was slow. Few classics were printed out of Italy before 1480, or, indeed, until the last ten years of that century. The *De Officiis* of Cicero, it is true, had appeared at Mentz in 1465,—the first portion of any classical work committed to the press, unless precedence is given to the *De Oratore* of Sweynheim and Pannartz at Subiaco. But with that exception the first impressions of *Terence* and *Valerius Maximus* at Strasburg, and of *Sallust*, and, perhaps, *Florus* at Paris, are all that Cisalpine presses contributed of that kind within the period under review. The first appearance of *Valleius Paterculus* at Basel and of *Anacreon* and *Menander* at Paris was not until the next century was well advanced. In Spain the first classical book was a *Sallust* of 1475. In England, the earliest was a *Terence*, printed by Pynson in 1497; but, besides that, *Virgil, Sallust*, and Cicero's *Offices*, together with two Greek books, were the only classics published down to 1540. A complete edition of *Cicero*, printed in 1585 at London, was the chief Latin work up to that date. A neat edition of Homer's *Iliad* appeared in 1591, and the first impression of *Herodotus* in this country came out in the same year at Cambridge. Our early printers were content with French translations for their versions and abridgments; and Gawin Douglas, in the preface to his translation of *Virgil*, records his indignation at the injustice done to the "divine poet" by the second-hand translation of Caxton.

Most of the Latin classics had appeared in print before the art was employed on any Greek author. This was due rather to the want of adequate editorship than to any indifference to Greek in Italy; for the taste for that language had steadily increased since the arrival of the learned Greeks from Constantinople, and the want of printed editions became general before the close of the 15th century. To Aldus belongs the glory of ministering to that desire, by publishing, in quick succession and with singular beauty and correctness, almost all the principal authors in that tongue. Beginning in 1494 with *Museus's Hero and Leander*, he printed before 1516, the year of his death, upwards of sixty considerable works in Greek literature. The list includes the first impressions of *Aristophanes, Herodotus, Theocritus, Sophocles, Thucydides, Euripides, Demosthenes, Pindar, and Plato.* The *editio princeps* of Aristotle is the finest of his productions. Himself, in several cases, editor as well as printer, he had the assistance of the most learned scholars of the day; and the handy size of his octavos, which he substituted for the more cumbersome quartos after his removal from Venice, added to the popularity of his editions. Within two years after Aldus commenced his labours, Greek printing began at Florence with the works of Callimachus,<sup>1</sup> Apollonius Rhodius, and Lucian; at Rome, however, the earliest work was the *Pindar* of Calliergus in 1515.<sup>2</sup> At Paris the first Greek press of importance was established in 1507 by Gourmont, but the days of its chief celebrity date from his successors Colines and Stephens. Aldus, though the most prolific, was not the earliest Greek printer. The first entire work in that language was the *Grammar* of Constantine Lascaris, printed by Zarot at Milan in 1476. Homer's *Batrachomyomachia* was the earliest printed Greek classic; his complete works first appeared in the

Florence Homer of 1488, a volume which, Gibbon observes, "displays all the luxury of the typographical art." Besides these works, the *Orations* of Isocrates had appeared in 1493. Aldus has been unduly eulogized by his biographer, M. Renouard,<sup>3</sup> who has represented him as having given an entirely new direction to the art of printing, and indeed to the literary taste of Europe. His taste for Greek he had imbibed from the age: he saw that there was a great and growing want of Greek books, and his peculiar praise lies in this, that he applied himself to supply it with much more constancy and skill and with much more learning than any other printer of that period. His preface to Aristotle's *Organon*, published in 1595, amply recognizes the demand for Greek books. "Those," he says, "who cultivate letters must be supplied with books necessary for that purpose; and till this supply is obtained I shall not be at rest."<sup>4</sup>

The absolute rarity of the first editions of the classics it is difficult to determine with precision. They have been much prized by collectors, especially during last century, though their price has fluctuated considerably at different times. The date of some, as for instance, of *Juvenal, Q. Curtius*, and *Horace*, is conjectural; and the last-named is one of four classics,—*Luacan, Plutarch*, and *Florus* being the other three,—of which the printer is unknown. The Naples edition of *Horace* of 1474 is called by Dibdin<sup>5</sup> the "rarest classical volume in the world," and it was chiefly to possess this book that Earl Spencer bought the famous library of the duke of Cassano. Of the first edition of *Lucretius* only two copies are believed to exist; and not one in its integrity of *Azoguidi's editio princeps* of *Ovid*. On the other hand, there are several classical authors, of whom the second and even later impressions are far the most valuable and scarce. The intrinsic merit of the *editio princeps* of the classics is too unequal to admit of any general description. Their chief value, in a literary sense, consists in the security afforded by printing against the further progress of transcriptional error; but it would be a great mistake to imagine that the text was then finally established. Maittaire gives precedence to their authority as equivalent to that of the MSS. from which they were taken, but the question obviously turns on the character of those MSS. themselves. Later discoveries and the progress of critical research confirm the testimony of many of the first editors, in their prefaces,<sup>6</sup> regarding the insufficiency and mutilated character of their materials. Thus Grævius observes of the celebrated *editio princeps* of Cicero's *De Officiis* by Fust, that it was printed from a very inaccurate manuscript. Schellhorn, in his *Anacriticæ Literariæ*, insists, with good reason, on the want of collation among the first editors. Frequently the first manuscript that offered itself was hastily committed to the press, in order to take advantage of the recent discovery; and fragments of different manuscripts were patched together to form *Opera Omnia* editions, without regard to the relative authority of their contents. On the other hand there are first editions which represent a single lost archetype, and whose value, therefore, cannot be exaggerated, while others

<sup>1</sup> *Annales de l'Imprimerie des Aldes*, Paris, 1825, and third edition in 1834. Renouard afterwards published a similar work on the family of the learned printers, Robert and Henry Stephens, *Annales de l'Imprimerie des Estiennes*, Paris, 1837, 2 vols. 8vo.

<sup>2</sup> The preface is translated in Roscoe's *Leo X.*, i. 110.

<sup>3</sup> The bibliography of first editions of the classics is treated copiously by this writer in his *Introduction to the Classics*, his *Bibl. Spenseriana*, and his *Catalogue of the Cassano Collection*. The prices of many valuable first editions at a sale in London in 1831 are given at the end of the last-mentioned work. See also a curious chapter on "First Editions" in Marchand's *Histoire de l'Imprimerie*.

<sup>4</sup> These prefaces have been edited by Botfield, with an introduction of some merit.

<sup>1</sup> This *editio princeps* is among the scarcest of Greek capital letter productions.

<sup>2</sup> Roscoe's *Leo X.*, li. 257-8. Greek types, according to Panzer, had first been used in a treatise of Jerome, printed at Rome in 1468; and detached passages are found in some of the first copies of Latin authors.



represent copies of undoubted merit. La Grange assures us, in the preface to his French translation of *Seneca*, that he never, in any case of difficulty, consulted the first edition of 1475, without finding a solution of his doubts. The fact is that each *editio princeps* must be judged by itself. It is to such scholars as Turnebus, Muretus, and Lipsius that we owe a juster estimate of their relative value, than prevailed in the early days of printing. Victorius has been called the "Sospitator Ciceronis;" and the real restorers of Greek learning are to be found in Scaliger, Casaubon, Budæus, Camerarius, and Stephens. The text of the classics has been slowly and laboriously constructed, and in some cases, as with Aristophanes, Dion Cassius, and Pliny, among others, a manuscript, discovered in modern times, has superseded entirely the authority of early editions. This branch of the subject is fully treated in an article in the *Edinburgh Review* on "Classical Manuscripts and First Editors" (Jan. 1873).

Sets of the classics, more or less complete, have been published at different times, and for different purposes. Among the earliest and most important are the *Delphin* editions, prepared, by order of Louis XIV., at the instance of the duke de Montausier, for the use of the Dauphin. The duke had been in the habit of studying the classics on his campaigns, and the want of books of reference appears to have suggested to him the idea of a uniform series of the principal classics, with explanatory notes and illustrative comments. On his becoming governor to the Dauphin, the scheme was carried into execution; and Huet, bishop of Avranches, a preceptor of the prince, was entrusted with the choice of authors and editors, and with the general supervision of the series. A list of the editors is given by Baillet in his *Critiques Grammaticales*. The collection, which, including Danet's *Antiquities*, extends to sixty-four volumes quarto, is of very unequal merit; but the copious verbal indices, which were added by the direction of Huet, afford a useful means of reference to particular passages. Only Latin classics, however, are included in the series; and "it is remarkable," as Dr Aikin observes, "that *Lucas* is not among the number. He was too much the poet of liberty to suit the age of Louis XIV." The entire collection, enlarged with the notes of the *Variorum* editions, was republished in 1819-1830, by A. J. Valpy, forming in all 185 vols., 8vo. These *Variorum* classics number upwards of 400 volumes, and were edited in the course of the 17th and 18th centuries. A complete collection is very rare; Peignot mentions one belonging to M. Mel de Saint-Ceran, which was sold for 3000 livres. For the names of the authors and commentators see De Bure's *Bibliographie*, vol. vii. p. 680, and Osmont's *Dictionnaire*, vol. ii. p. 411. The editions most prized by collectors are the Elsevirs and the Foulises. The *Elsevirs*, or properly *Elseviers*, were a family of famous printers and booksellers at Amsterdam, no fewer than fifteen of whom carried on the business in succession from 1580 to 1712. Their *Pliny* (1635), *Virgil* (1636), and *Cicero* (1642), are the masterpieces of their press; the last of the family brought out editions in 12mo and 16mo.<sup>1</sup> A full list of their publications is given in Brunet's *Manuel*, vol. v., *ad fin.* The *Annales de l'Imprimerie Elsevirienne*, by Pieter, 1851 and 1853, supersedes the authority of previous works on that subject, and contains much curious research. The project of reprinting the Elsevir editions, which originated in 1743 with the Abbé Lenglet-Dufresnoy, led to the famous *Barbou* collection, commenced by Costelier and continued by Joseph Gaspard Barbou, one of the family of Paris printers and booksellers of that name,

and extending finally to 76 volumes in 12mo. Lemaire's *Bibliotheca Classica Latina*, 1819-26, which was dedicated to Louis XVIII., is one of the best collections of Latin classics which exists in France, although the list of authors is incomplete, and the notes far too voluminous. The whole series extends to 154 volumes in 8vo. The editions of Robert and Andrew Foulis, printers at Glasgow, were the finest which Britain produced during the 18th century. Their *chef d'œuvre* was the *Horace* of 1744, each printed sheet of which, probably after the example of Robert Stephens at Paris, was hung up in the college of Glasgow, and a reward offered for the discovery of any error.

Among the most useful bibliographical accounts of the classics may be mentioned the following:—*A View of the Various Editions of the Greek and Roman Classics, with Remarks*, by Dr Harwood,—this work, first published in 1775, is still a convenient manual of reference; *De gli Autori Classici, sacri e profani, Greci et Latini, Bibliotheca portatile*, 2 vols., Venice, 1798, a compilation of the Abbé Boni and Bartholomew Gamba, and containing a translation of the preceding; Dibdin's *Introduction to the Knowledge of Rare and Valuable Editions of the Classics*, first published in 1802, and greatly enlarged in subsequent editions, containing a full account of Polyglot Bibles, of the Greek and Latin editions of the Septuagint and New Testament, and of lexicons and grammars; *A Manual of Classical Bibliography*, by J. W. Moss, 2 vols., 1825, noticing at length the different translations of the classics, the prices obtained for the rarer editions at public sales being also specified; *A View of the English Editions and Translations of Greek and Latin Authors*, by Brugemann, London, 1797; Engelmann's *Bibliotheca Scriptorum Classicorum*, Leipzig, 1847-53, containing an account of German editions between 1700 and 1852, while Greek and Latin classics printed in Germany and France are noticed in the *Répertoire de la littérature ancienne*, by F. Schöll, Paris, 1808; *Handbuch der Classischen Literatur*, by G. D. Fuhrmann, Halle, 1807-10, 5 vols. 8vo.; Hebenstreit's *Dictionarium*, Vienna, 1828; and the *Handbuch der Classischen Bibliographie*, Leipzig, 1830-34,—all of them works of considerable merit. The improved editions, by Harless and Ernesti, of the *Bibliotheca Græca* and *Bibliotheca Latina* of Fabricius are well known as immense magazines of classical lore, but they extend over a much wider field of inquiry than is embraced by bibliography.

#### V. Anonymous and Pseudonymous Books.

Books of this class originate, generally speaking, either from the necessities or the caprice of authorship.<sup>2</sup> Their number, however, has been such as to occupy, at an early time, the attention of bibliographers. In 1669 Frederick Geisler, professor of public law at Leipsic, published a dissertation, *De Nominum Mutatione*, which he reprinted in 1671, with a short catalogue of anonymous and pseudonymous authors. About the same time, a similar but more extensive work had been undertaken by Vincent Placcius, professor of morals and eloquence at Hamburg, which was published in 1674 with the title *De Scriptis et Scriptoribus anonymis atque pseudonymis Syntagma*, in which the writer invited information from learned men in Europe. Four years later, John Decker, a German lawyer, published his *Conjectura de Scriptis adespotis, pseudographis, et supposititiis*, which was republished in 1686, with the addition of two letters on the same subject, one by Paul Vindingius, a professor at Copenhagen, and the other by the celebrated Peter Bayle. In 1689 appeared the *Centuria plagiariorum et pseudonymorum* of John Albert Fabricius, as well as a letter to Placcius from John Mayer, a clergyman of Hamburg, under the title—*Dissertatio Epistolica ad Placcium, qua anonymorum et pseudonymorum farrago exhibetur*. The complete fruits of Placcius's researches were published after his death in a folio volume at Hamburg in 1708, by Matthew Dreyer, a lawyer of that city. The work was now entitled *Theatrum Anonymorum et Pseudonymorum*; and, besides an Introduction by Dreyer and a Life of Placcius by Fabricius, it contains, in an

<sup>1</sup> Without disparaging the Elsevirs, it must be remembered that their texts were mere re-impressions, and did not rest, like those of Aldus and the Stephens, on ancient MSS.

<sup>2</sup> Baillet, in his *Jugemens des Savans*, l. 1690, notices several motives for concealed authorship.

Appendix, the before-noticed treatises of Geisler and Decker with the relative letters of Vindingius and Bayle, and the Dissertation of Mayer. This elaborate work contains notices of six thousand books or authors; but it is ill-arranged and frequently inaccurate, besides being cumbered with citations and extracts, equally useless and fatiguing.

The subject of false and fanciful names attached to books had been undertaken in France by Adrien Baillet, nearly about the same period that Placcius commenced his inquiries. In 1690 this author published his *Auteurs Déguisez*; but this is little more than an introduction to an intended catalogue which Baillet never completed, being deterred, as Nicéron says, by the fear lest the exposure of concealed authors should in some way or other involve him in trouble. In this piece, which was reprinted in the sixth volume of De La Monnoye's edition of Baillet's *Jugemens des Savans*, there are some curious literary anecdotes, especially with reference to the passion which prevailed after the revival of letters for assuming classical names. In Italy these names were so generally introduced into families, that the names of the saints, hitherto the common appellatives, almost disappeared from that country. A similar rage for assuming the names of celebrated authors was common among French writers in the 18th century.

The taste for this kind of research, which the work of Placcius had diffused in Germany, produced several supplements to it in that country. In the *De Libris anonymis et pseudonymis Schediasma*, published by Christopher Augustus Neumann in 1711, there is a dissertation on the question, Whether it is lawful for an author either to withhold or disguise his name? which question he decides in the affirmative. But the most considerable of these supplements was that published in 1740 by John Christopher Mylius, librarian at Hamburg. It contains a reprint of the *Schediasma* of Neumann, with remarks, and a list of 3200 authors, in addition to those noticed by Placcius. The notices of Mylius, however, are limited to books in Latin, French, and German. The younger De Bure occupied himself partially with these researches; his omissions were supplied by M. Née de la Rochelle in his *Table destinée à la Recherche des Livres anonymes qui ont été annoncés dans la Bibliographie Instructive*, Paris, 1782. The names of several anonymous writers were discovered by Rollin in his *Traité des Etudes*, by Jordan in his *Histoire d'un voyage littéraire fait en 1783*; and by Bayle in his *Réponse aux Questions d'un provincial*. In 1758 the Abbé de la Porte published his *France littéraire*,<sup>1</sup> which was republished with large additions in 1769 by the Abbé de Hebrail. Both editions contain numerous errors, many of which, unfortunately, were reproduced by Ersch, librarian of the university at Jena, in his enlarged publication of 1797-1806, a work in other respects of solid merit and utility. The *Dictionnaire des Anonymes* of the Abbé Duclos is serviceable but incomplete; it has been abridged by Fournier in his *Dictionnaire portatif de Bibliographie*, Paris, 1805.

Among later authorities may be mentioned Weller's *Maskirte Literatur der älteren und neueren Sprachen*, Leipsic, 1858, and *Die falschen und fingirten Druckorte*, 1858, and the *Dictionnaire des Pseudonymes*, by G. Heilly, 1869. Conspicuous in merit is the *Dictionnaire des Ouvrages Anonymes et Pseudonymes*, by M. Barbier, librarian to Napoleon I., the last edition of which is as recent as 1872. It comprises a vast number of articles, but the plan does not extend to foreign productions, except those

which have been translated into French. His labours have been supplemented and improved upon by De Manna, in his *Nouveau Dictionnaire* of 1868, and by Quéraud in his *Supercherries littéraires dévoilées 1847-53*. The list of anonymous writers in France includes Pascal, La Rochefoucauld, and Cardinal Richelieu. The authorship of Montesquieu's *Esprit des Loix* was disguised, on its appearance in 1748, as was the *Anti-Machiavel*, written by Frederick II. of Prussia, and published by Voltaire, who himself wrote several works anonymously. For Italian literature there are Vinc. Lancetti's *Pseudonima*, published at Milan in 1836; and Melzi's *Dizionario di Operi Anonime e Pseudonime di Scrittori Italiani*, Milan, 1848-59.<sup>2</sup> In England the practice of anonymous writing, in spite of the example of journalism, has never largely prevailed; but the *Letters of Junius* are a conspicuous example of authorship successfully concealed. The *Eccè Homo* is a recent instance among the works of current celebrity. The *Handbook of Fictitious Names*, by Olphar Hamst, London, 1868, is a useful and amusing guide, especially to English authors of the lighter literature of this century. Works of this class, however, are most applicable to countries in which the liberty of the press has been most restricted.

#### VI. *Condemned and Prohibited Books.*

Books supposed hurtful to the interests of government, religion, or morality have been sometimes condemned to the flames, sometimes censured by particular tribunals, and sometimes suppressed. Such methods of destruction have been followed in various countries, with regard both to their own and to foreign productions; and lists have been published from time to time of the works so interdicted.

Heathen antiquity supplies some instances of the burning of obnoxious books, such as the reported destruction of the works of Pythagoras at Athens, and of astrological works, as well as the writings of Labienus, by Augustus at Rome. Some Greek works, alleged to have been found in the tomb of Numa in 181 a.c., and ascribed to him, were burnt by order of the Senate; the story of their discovery, however, is a mere fabrication. Tacitus mentions a *History* by Cremutius Cordus, which the Senate, to flatter Tiberius, condemned, because it designated C. Cassius the last of the Romans.<sup>3</sup> Diocletian, according to Eusebius, caused the Scriptures to be burnt, but the early Christian Church was not slow in following the example of intolerance, and the charge of heresy was a ready instrument for putting down works alleged to be injurious to the faith. The first recorded instance is that of Arius, whose writings were condemned to the flames at the Council of Niceæ, Constantine himself threatening with death those who should harbour any copies. The same fate befell the works of Nestorius at the Council of Ephesus, and those of Eutyches at Chalcedon. Pagan works were prohibited at the Council of Carthage in 400. Aristotle was forbidden by the church in the 13th century, but the restriction was relaxed in favour of the universities by Pope Nicholas V. A list of prohibited books is found in a decree of a council at Rome as early as 494.<sup>4</sup> But the chief rigours of persecution began with the Inquisition, and the crusade against literature increased in severity with the multiplication of books through the press. In 1515 the Council of Lateran at Rome appointed clerical censors to examine all works before publication, as if, to use Milton's indignant remonstrance, "St Peter had bequeathed to them the keys of the

<sup>1</sup> See Fetsholdt's chapter on "Maskirte Literatur," in his *Bibliische Bibliographie*.

<sup>2</sup> See the chapter on "Book-Censors" in Beckmann's *History of Inventions*.

<sup>4</sup> Labbe's *Conc. H.*, col. 938-94.

<sup>1</sup> Quéraud's *France Littéraire*, Paris, 1846, contains a copious list of such works from 1700 to 1846.

press as well as of Paradise.<sup>1</sup> In 1543 Caraffa issued an order that no book should be printed without leave from the Inquisition, and booksellers were, accordingly, required to send in catalogues. Brunet mentions, however, a list of prohibited authors, prepared by order of Charles V., which was printed at Brussels in 1540, and is the earliest of its kind. An *Index generalis scriptorum interdactorum* was published by the Inquisition at Venice in 1543, and similar catalogues followed from the universities of Paris and Louvain. The first Index of the Court of Rome appeared in 1558, and was reprinted in 1559. The subject was discussed at the Council of Trent, who delegated the right of supervision to the Pope, and the result was the *Index Tridentinus* of Pius IV.,—the first strictly Papal Index,—which was printed by Aldus at Rome in 1564. Thence began a long series of literary proscriptions, which was continued by the Congregation of the Index,<sup>2</sup> and of which one of the immediate effects was to drive printing to Switzerland and Germany. The right of dictating what books should or should not be read was a consequence of the claims of the Papacy over the conscience and morals of mankind; and the vitality of persecution has been preserved within the Romish Church by the consistent exercise of such pretensions. The bibliography of these Expurgatory Indexes has been copiously treated.<sup>3</sup> Among the earlier victims were Galileo and Copernicus; and English literature is represented by such names as Gibbon, Robertson, Bacon, Hallam, Milton, Locke, Whately, and J. Stuart Mill. In Spain the power of the Inquisition, provoked by the invasion of Lutheranism, was wielded by Fernando de Valdes, whose catalogue of 1559 formed the model of that issued by Pius IV. in the same year. An edict of Philip II. was published at Antwerp in 1570, and a general Index of all books suppressed by royal authority appeared at Madrid in 1790. It is noticeable that Smith's *Wealth of Nations* has been proscribed in that country, "on account of the lowness of its style and the looseness of its morals." A list of books suppressed in France between 1814 and 1850 has been edited by Pillet. For the more general notices of prohibited literature, we refer our readers to Klotz's *De Libris auctoribus suis fatalibus*, 1761; to Struvius's *Bibliotheca Hist. Litter.* vol. iii. c. 9; to the Dissertations in the seventh volume of Schelhorn's *Associtates Literariae*, which contain much curious information; to Brunet's *Livres Supprimés et Condamnés*; and to Peignot's *Dictionnaire Critique et Bibliographique des principaux Livres condamnés ou fés, supprimés, ou censurés*, 2 vols., Paris, 1806. This last work is agreeably written, and gives a copious list of authorities on the subject; but its enumeration of principal works is far from complete, and comparatively few English books are mentioned.

A comprehensive account of works condemned or suppressed in England has yet to be written, but an article in the *Edinburgh Review*<sup>4</sup> supplies some interesting materials on this subject. Peacock's *Precursor*, which the author burnt with his own hand, is an early instance, before the invention of printing. The "war against books,"<sup>5</sup> however, began under Henry VIII., the sudden-

ness of whose breach with Rome is shown by the circumstance that, whereas in 1526 anti-popery books were condemned as heretical, in 1535 all books favouring popery were decreed to be seditious. Several of the early translations of the Bible were suppressed,—Tyndal's version among others. As many copies of that work as the superior clergy could buy up, were publicly burnt at St Paul's on Shrove Tuesday, 1527, Fisher, bishop of Rochester, preaching a sermon on the occasion. An edition of the Bible was suppressed for a misprint, the printer having omitted the word "not" in the seventh commandment, but a copy survives in the Bodleian. A general burning of unlicensed books was ordered by the king in 1530, the *Supplication of Beggars*, a well-known invective against Wolsey, being included in the list. Another catalogue was issued in 1546 by proclamation, and the Act 3 and 4 Edward VI. made a raid against missals and books of devotion. The regulations of the Star Chamber in 1585 claimed the power of licensing and seizing books, and their scrutiny was as rigorous as that of the Inquisition. Nevertheless the reign of Elizabeth was fruitful in "schismatic and libellous tracts."<sup>6</sup> A notable offender was Cardinal Allen's *Admonition*, containing a furious attack on the queen, of which a copy remains in the British Museum; and the famous Martin-Marprelate tracts raised a storm of opposition. In 1607 Dr Cowell's *Law Dictionary* was burnt by order of the House of Commons, for its assertions of divine right in favour of James I.; and the *King's Book of Sports* incurred the same fate at the hands of the Puritans in 1644. The persecutions of the Star Chamber include the punishment of Prynne for his *Histriomastix*, and the still more barbarous mutilation of Dr Alexander Leighton for his two works, *The Looking Glass of the Holy War*, 1624, and *Zion's Plea against the Prelacy*, 1628. Milton's *Ελευθελολογία* and the *Defensio pro Populo Anglicano* were suppressed after the Restoration. Defoe's *Shortest Way with the Dissenters* was burnt by Parliament in 1703; and sixty years later Wilkes's *North Briton* incurred the same fate. The last instance of authorized book-burning in Great Britain was in 1779, when the *Commerical Restraints of Ireland considered*, by the Hon. Halv Hutchinson, was given to the flames.

This branch of bibliography has a peculiar interest to the literary historian. It serves to indicate, for the most part, periods of political excitement or religious intolerance. Fortunately, however, the efficacy of persecution has been frustrated by the disseminating power of the press. *Punitis ingenii, gliscit auctoritas*, is the reflection of Tacitus; and experience has abundantly proved that it is easier to destroy an author than his book. Melancholy as are the records of literary martyrdom, there remains this satisfaction that, in the main, the policy of oppression has defeated its own end.

#### VII. Catalogues and Bibliographical Dictionaries.

The first catalogues, after the invention of printing, were those of the early printers, who, as booksellers, published sale-lists of their works, to attract the attention of the learned. The most ancient of these *catalogi officinales*—the humble predecessors of Bohn's gigantic catalogue—is a simple leaf, entitled *Libri Græci impressi*, printed by Aldus in 1498. The list consists of fourteen articles, distributed into five classes,—grammar, poetry, logic,

curious list of Lutheran works prohibited in England is given in Strype's *Ecol. Memorials*, i. 165.

<sup>6</sup> The registers of the Stationers' Company contain entries of books ordered for "immediate confiscation" in 1599. See *Notes and Queries*, 3d series, xii. 486. Volume ii. of Wood's *Alten. Oena.* was burnt at Oxford in 1693 by the apparatus of the university, for some alleged reflections on the memory of Lord Clarendon.

<sup>1</sup> *Liberty of Unlicensed Printing.*

<sup>2</sup> A complete list of their catalogues is given in Fetshold's *Bibl. Bibliogr.*, "Verbotene Literatur."

<sup>3</sup> See the *Index Librorum prohibitorum a Pontificis auctoritate, in usum Bibliothecæ Bodleianæ*, by Tho. James, 1627; Francis, *De Populorum Indictibus*, Leipzig, 1684; *Thesaurus Bibliographicus an Indictibus Librorum prohibitorum comparatus*, Dresden, 1748. Oznot, in 1826, published a complete list of all books condemned by the court of Rome from the date of printing to 1825, with the dates and decrees of their condemnation. The best known, though not the latest, edition of the *Index* was issued by Pius VII. in 1819.

<sup>4</sup> *Suppressed and Censured Books*, vol. cxxiv. July, 1871.

<sup>5</sup> See the final chapter in Darnell's *Annals of Literature*. A

philosophy, and theology, and may be regarded as one of the first attempts to apply a system of classification to printed books. Its interest is enhanced by its containing the price of the books advertised for sale. The increasing commerce in literature was at once a cause and a consequence of similar catalogues; and the example of Aldus was followed by the Stephens, and by Colines, Wechell, and Vascosan, and other French printers of the first half of the 16th century, whose lists are given in vols. ii. and iii. of Maityaire's *Annales Typographiques*, the divisions of subjects increasing with the spread of printed literature. In England the earliest known sale-list of printed books was published by Andrew Maunsell, a London bookseller, in 1595, and contains the titles of many works now lost or forgotten. In 1554 or 1564<sup>1</sup> appeared the first printed catalogue of the Frankfort book-fair, published by George Weller, a bookseller at Augsburg; and in 1604 it was followed by the general Easter catalogue, printed by permission of the Government. These catalogues of the different book-fairs were collected together in 1592 by Cless—whose researches included all books printed since 1500—and by Draudius in his *Bibliotheca Classica* (1611). The same has been done by Georgi in his *Bücher Lexicon* (1758), a catalogue of all works printed in Europe up to 1750.

The growth of the book-trade naturally promoted the spread of collections; and towards the end of the 17th, and especially during the 18th century, book-catalogues of every description multiplied rapidly. Their progress is copiously treated of in Nichols's *Literary Anecdotes*, vol. iii. pp. 608–693.<sup>2</sup> Most private collections, at first, appear to have been bought and sold *en bloc*; and it was through the catalogues, compiled in many instances by learned and well-qualified librarians, that a more critical and discriminating estimate of their contents was formed. P. Garnier in 1678 prepared an excellent catalogue of the library of the Jesuit Collège de Clermont at Paris, using the materials, like other bibliographers after him, for a classified system of his own. Dr Johnson and Oldys were the joint editors of the *Bibliotheca Harleiana*, which they prepared for Osborne the bookseller, who bought the library of the earl of Oxford; and Maityaire drew the scheme of arrangement. The earliest catalogues of public libraries were simple inventories, disposed in alphabetical order, with, at most, a few biographical notices interspersed; yet they paved the way, in the hands of Conrad Gesner, for the study of "pure" bibliography. The compilation of *catalogues raisonnés* was deferred till the 18th century, when the labours of French librarians or booksellers, such as Piget, Prosper Marchand, Martin, Barrois, Baillet, and the De Bures, created by that means a public taste for books. The greatest work of this kind was the French *Bibliothèque Royale*, begun in 1739, and finished in 10 vols. in 1753. Part i., relating to printed books, was superintended by the Abbé Sallier and Boudot. In a perfect *catalogue raisonné* alphabetical arrangement is dispensed with; every work occupies its proper place in regard to the light it throws on the subject treated, and the ground traversed by the author. "Catalogues of this sort," says Dibdin, "are to bibliographers what reports are to lawyers;" and Maityaire terms them "proces-verbaux littéraires, servant à décider une infinité de questions qui s'élevaient sur la bibliologie." The consolidation of these detached catalogues was a consequence of the increased requirements of learning, and the *Bibliotheca*, or registers of particular libraries, supplied the

first materials for a general dictionary of reference. Bibliography, thus represented, is the *codex diplomaticus* of literary history, with a field of research co-extensive with the innumerable productions of the press. But a universal dictionary of this kind is but a dream of bibliographers; nor would any single compiler be equal to the task. The *Bibliotheca Universalis* of Gesner in 1545 is the earliest and almost the only effort of this nature. His work professed to include the titles of all known books, existing or lost, but he confined himself to those in Hebrew, Greek, and Latin. The first volume is classed alphabetically, according to the authors' names; the second contains a distribution of subjects, and is divided into nineteen books. Balthazar Ostern, in 1625, published a *Bibliothèque Universelle*, or catalogue of printed books from 1500 to 1624. A general survey of printed literature might be made to the end of the 16th century; but the idea is now wholly chimerical, since the number of books surpasses all human calculation. The *Bibliotheca Britannica, or General Index of British and Foreign Literature*, by Dr Watt of Glasgow, published in 1824, 4 vols., is perhaps the nearest modern exposition of Gesner's idea. All so-called general dictionaries are, in fact, written on a selective principle of some kind, the only means, as Baron de Reiffenberg remarks, of achieving utility and completeness. Erach, the founder of modern bibliography in Germany, published his *Allgemeines Repertorium der Literatur* in 1793–1809; but the first really comprehensive work in that country was Ebert's *Allgemeines Bibliographisches Lexicon*, Leipzig, 1821–1830, an English translation of which was printed at Oxford in 1837, 4 vols. 8vo. Kaiser's *Vollständiges Bücherlexicon*, and Heinsius's *Allgemeines Bücherlexicon*, with the continuation by Schultz, are useful works of reference; but their contents, as might be expected, are far from justifying the epithet of universal. Osmont, Caillien, and other French compilers on a large scale, limited their notices to rare and remarkable books; and De Bure in his *Bibliographie Instructive* only included productions of inferior repute, because his original materials were too scanty to illustrate all the divisions of a complete system and comprise what he termed a "Corps de Bibliographie choisie." Brunet's *Manuel du Libraire* was the first work which embraced in alphabetical order what was most precious in the literature of all times and nations. It was first published in three volumes, 8vo, in 1810, and has since passed through several editions. It is far richer in English and German books than any of the preceding compilations, and its plan is such as to afford all the advantages both of a dictionary and a classed catalogue. As a practical work of reference, whether to the bibliographer or the student, it is the most complete dictionary yet published on a scale so comprehensive. The *Bibliographie Universelle* (Manuels-Roret), Paris, 1857 contains a copious list of the leading works on the different subjects of learning, which are arranged in alphabetical order, and a succinct summary of the principal editions of an author's work, including the ancient classics. Among works avowedly devoted to *special* bibliography, some are limited to the productions of certain epochs. The first century of printing has been an attractive subject of research, as has been noticed above in the chapter on early printed books. The *Bibliographie de la France* was the first trustworthy compilation of annual literature in that country. Of more immediate value for purely literary purposes are those dictionaries or catalogues which are restricted to particular branches of knowledge; and they have the advantage of being able to ensure greater fulness and accuracy, from the limited scope of their contents, than is available in a work professedly general. "Through the want of such," said Oldys, "how many authors have we who are consuming

<sup>1</sup> Le Mire (Mirusus), as quoted by Fabricius, says 1554; Labbe, Reimann, and Hennmann, quoting from the same source, say 1564.

<sup>2</sup> See also Caillien's *Dict. Bibliographique*; Dibdin's *Bibliomania*, 95–193, notes; and the "Catalogue des Bibliothèques Particulières" at the end of *Bibliog. Universelle* (Manuels-Roret), Paris, 1857.

their time, their quiet, and their wits, in searching for either what is past finding, or already found." A catalogue, in short, might be made of superfluous writings by authors who have dug in mines of literature already exhausted. The tendency, however, of modern bibliography is fortunately to subdivide the field of literature; and the student of any special department of learning need be at no loss for authorities to consult. Bale's *Illustrium Majoris Britannia Scriptorum Summarium* (1458), John Pits's *De Academicis et Illustribus Angliæ Scriptoribus* (1619), Bishop Tanner's *Bibliotheca Britannico-Hibernica* (1748), and Nicolson's *Historical Libraries*, 4to, 1776, are the earliest catalogues, on a large scale, of our national literature. A list of Saxon writers, by Wanley, forms the second volume of Hicke's *Thesaurus*. A *Critical Dictionary of English Literature and British and American Authors*, by S. A. Allibone, 3 vols., 1859-1872, is an industrious work. The *Bibliographer's Manual of English Literature*, by W. T. Lowndes, is indispensable to the collector; and for a first attempt of the kind, displays a singular degree of accuracy and research. His *British Librarian, or Book Collector's Guide*, 1839, purported to give a classed catalogue of books on English literature printed in Great Britain; he lived, however, to complete only six numbers of the division—*Religion and its History*. Dr Adam Clarke's *Bibliographical Dictionary*, 6 vols. 1803, is restricted to works in the learned and Eastern languages; his *Bibliographical Miscellany*, published in 1806 as a supplement, contains, among other matter, a full account of the English translations of the classics. To foreign literature belong, among others, Quéard's *La France Littéraire*, and the *Bibliothèque Historique* of Le Long; the *Bibliotheca Belgica* of J. F. Foppens, 2 vols., 1739; *Bibliotheca Hispana, Nova et Veteris*, by Nicholas Antonio, 1783-88; Haym's *Bibliotheca Italiana*; Worm's *Danske, Norske, og Islandiske Lærde Lexicon*, 1771-84; Nyerup and Kraft's *Almindeligt Litteratur Lexicon*, 2 vols., 1820; Georgi's *Allgemeines Europäisches Bücher-Lexicon*, 1742-58; and others which space forbids us to enumerate.

The works devoted to special branches of knowledge form a host in themselves, and we can only mention a few of them, by way of illustration. To theology belong such works as Le Long's *Bibliotheca Sacra*, 1723, and the *Bibliotheca Theologia Selecta*, by Walchius, 1757, as well as his *Bibliotheca Patristica*, new edition, 1834. Judaic literature is represented by Fürst, and Hebrew writers by Wolfius, 1716-33. Læpennus, a learned German divine of the 17th century, devoted separate *Bibliotheca* to theology, law, philosophy, and medicine, which were collected in his *Bibliotheca Realis*. His *Bibliotheca Juridica* has received several supplements by other writers, and is much the most valuable of his series. Bridgman's *Legal Bibliography*, and the valuable work of M. Camus, *Lettres sur la profession d'Avocat et Bibliothèque choisies des Livres de Droit*, deserve especial notice. The *Bibliotheca Historica* of Meusel relates to historical works of all ages and nations. An excellent catalogue of books of voyages and travel is given in the *Bibliothèque Universelle des Voyages*, by M. Boucher de la Richarderie, 6 vols., Paris, 1808. Dr Young's *Catalogue of Works relating to Natural Philosophy*, the *Catalogue Bibliotheca Historica Naturalis Josephi Banks*, by Dr Dryander, and Engelmann's *Bibliotheca Historico-naturalis*, Laipic, 1846 (supplement, 1861); the *Bibliotheca Mathematica* of Murhard, Lalande's *Bibliographie Astronomique*, and the *Bibliographie Agronomique*, are leading works, written on the same principle of selection. British Topography was treated by Gough in 1780, and by Upcott in 1818. Nisard's *Histoire des Livres populaires, ou de la Littérature du Colportage*, 1854, a curious and amusing work, may also be mentioned. Cöttinger's *Biblio-*

*graphis Biographique* contains a copious catalogue of purely biographical works.

For a comprehensive work of reference on special biographies we cannot do better than refer our readers to the *Bibliotheca Bibliographica*, by Dr Julius Fetsholdt Leipaic, 1866. Part i. relates to works on bibliography; part ii. to the bibliography of different nations; and part iii. to works connected with special branches of learning, which are classified into leading divisions. The *Répertoire Bibliographique Universel* of M. Peignot is a useful but ill-arranged work; it dates back, moreover, to 1812. The progress of knowledge and research, especially with regard to scientific subjects, obviously throws works of this description soon out of date to the student, who desires to be acquainted with the most recent as well as the earlier authorities. As landmarks, however, of the state of knowledge at different epochs, they are full of interest to the literary bibliographer.

#### VIII. On the Classification of Books.

The different methods, adopted from time to time, of classing books according to their subject matter, has occasioned a variety of so-called *systems* of bibliography, which it is important to notice, but which space forbids us to describe in detail. A distinction must be observed between a scheme of arrangement applied to a particular library, and limited therefore by its contents, and one which embraces in its divisions and subdivisions the entire range of literature. Nothing, on either head, is learnt from the Greeks and Romans; the classed catalogue of the library of St Emmeran at Ratisbon, compiled in 1347, and containing twelve divisions, is cited as the earliest specimen of its kind. (See LIBRARIES.) The most ancient system, in the wider sense of the term, is ascribed to the Chinese, who in the 13th century distributed the field of human knowledge into classes numbering from fourteen to twenty, with sectional subdivisions to each.

Classified systems suggested by or devised for particular libraries after printing had multiplied their contents, originated chiefly with librarians or compilers of catalogues. In 1587 Jean Baptiste Cardona wrote four treatises on the principal libraries of his day. His description of the library of the Escorial was followed in 1635 by Arias Montanus, whose catalogue divided the books there according to languages, separating MSS. from printed works, and distributed the whole into sixty-four classes. Their number was reduced by Casiri in his *Bibliothèque Arabico-Espagnole de l'Escorial*, Madrid, 1760. In 1631 John Rhodius proposed a scheme for the arrangement of the university library at Padua, which has been recently published in the *Serapeum* by Dr Hoffman, from a manuscript found in the town library at Hamburg, under the title of *Ein bibliothekarisches Gutachten abgegeben im Jahre, 1631*. His method is very similar to that of Claudius Clement, in his *Musei sive Bibliotheca tam privata quam publica constructio, instructio, cura usus*, 1635. A catalogue of the library of the Canon de Cordes, which was purchased by Mazarin, was compiled in 1643 by his librarian, Gabriel Naudé, whose *Addition à la vie de Louis XI.* contains much curious matter on bibliography, but who is best known, perhaps, from his defence of the massacre of St Bartholomew. His *Dissertatio de instruenda Bibliotheca* had previously appeared in 1627 in a French version, entitled *Avis pour dresser une Bibliothèque*, an English translation of which was published by John Evelyn in 1661; it was followed by several treatises of the same kind, containing minute instructions to librarians.<sup>1</sup>

<sup>1</sup> David Köller's *Sylloge aliquot scriptorum de bene ordinanda ac ornanda bibliotheca*, 1726, contains a full account of authorities up to

F. Bostgaard published in 1697 a *Projet d'une nouvelle méthode pour dresser un catalogue*, which serves to illustrate the difference between arranging a catalogue and a library. Naudé finds fault with the far-fetched refinements of his predecessors, and his divisions have the merit of being more simple and precise. "It is certain," says Mr Edwards, "that a good catalogue will require a much more minute classification than would be either useful or practicable in the presses of a library."<sup>1</sup> A confusion between these two distinct objects has largely pervaded the "system" of even later writers, who have supposed the same nicety and exactness to be equally necessary and equally practicable in both. Where there is a classed catalogue, the grand objects of a systematic arrangement are sufficiently provided for, independently of the location of the books on which so much fanciful lore has been expended. If there be no classed catalogue, it is tolerably clear that, for purposes of convenient and ready reference, a minute classification of books on the shelves, however accurate, may tend only to bewilder and confuse. Simplicity is the readiest means to aid the memory and abridge the labour of the librarian; and this object can be attained by a much more elementary division of books than could be tolerated in any classified catalogue extending to details.

These remarks apply largely to the ordinary system of modern French bibliographers, the origin of which is variously ascribed to Bouillaud, Garnier, and Martin. Priority of date appears to belong to Bouillaud, for his *Bibliotheca Thuana*, or sale-catalogue of the famous library of De Thou, had existed in MS. some time before it was edited by Quesnel in 1679. His system embraces five classes, theology, jurisprudence, history, philosophy, and literature,—the last including heterodox and miscellaneous works. The catalogue by P. Garnier of the library of Clermont, entitled *Systema Bibliotheca Collegii Parisiensis Societatis Jesu*, was published two years previously. The headings embrace 461 subdivisions, of which 74 belong to theology, 88 to philosophy (a class clumsily and confusedly arranged), 227 to history, and 72 to jurisprudence. In 1709 appeared Prosper Marchand's system, developed in his *Catalogus bibliotheca Joachimi Faultrier*. In his preface he attacks the system of Naudé, and, after treating of the different methods, viz. the order of nature, of nations, of languages, of time, and alphabetical, sums up his divisions into theology, or divine knowledge; philosophy, or human knowledge, separated into belles lettres and sciences; and history, or the knowledge of events. Bouillaud's system, as modified by Marchand, was adopted by Gabriel Martin in most of the catalogues, amounting to nearly 150, which he published between 1711 and 1760, and, afterwards, with some enlargement of subdivisions, by De Bure in his *Bibliographie Instructive*. The result of their successive labours, which is known as "the system of the Paris booksellers," is the one commonly adopted in France, and consists of theology, jurisprudence, sciences and arts, literature, and history. Some changes, it is true, were afterwards proposed. M. Ameilhon, in a paper published in 1799 in the *Memoirs* of the French Institute, suggested as primitive classes,—grammar, logic, morals, jurisprudence, metaphysics, physics, arts, belles lettres, and history,—his Revolutionary sympathies inducing him to discard theology from the list. But the system, finally elaborated by Martin, survived to govern the classification of the principal libraries in his country. Of

the various innovations, the system of Dannon in his *Mémoires sur la Classification des Livres d'une grande Bibliothèque*, 1800, is frequently cited as the best. Since then the Paris scheme has been modified by bibliographers like Barbier, Achard, and Brunet; by M. Merlin in his catalogue of the library of Baron Silvestre de Sacy (1842); and by M. Albert, in his *Récherches sur les principes fondamentaux de la classification d'une Bibliothèque*, Paris, 1847. Olenin's system (1808), for the Imperial library at St Petersburg, separated sciences from arts, and introduced philology as a distinct class. Dr Conyers Middleton in 1723 submitted a scheme to the senate of Cambridge for the classification of the university library; the classes proposed by him being these—*theology, history, jurisprudence, philosophy, mathematics, natural history, medicina, belles lettres, (libera humaniores), and miscellaneous*. Hartwell Horne's *Outlines for the Classification of a Library*, based on the Paris system, were submitted about the same time to the Trustees of the British Museum. A serviceable "Scheme for Town Libraries" is embodied in the chapter of Mr Edward's book previously quoted.

Of the more general "systems," based on a survey of the field of human knowledge, and not immediately directed to the requirements of a library, a brief notice must suffice. The earliest system, in this sense of the word, is commonly ascribed to Conrad Gesner, the founder, as Dibdin calls him, of pure bibliography. Yet he was, in fact, preceded, however feebly, by Alaxo Vanegas, whose work, published at Toledo in 1540, forms the first imperfect type of future efforts of that kind. His divisions are fourfold, viz.: "*Original*—of the harmony between predestination and free will; *Natural*—of the philosophy of the visible world; *Rational*—of the function and use of reason; *Revealed*—of the authority of the Scriptures." Gesner's, however, was the first comprehensive attempt at a general encyclopædia of literature, constructed in the form of a catalogue. His system was first published in 1548 as an index of matters to his *Bibliotheca Universalis*, under the title of *Pandectarum sive Partitionum Universalium Libri XXI.* Florian Treffer, a Bavarian Benedictine, published at Augsburg in 1560 a *Méthode de classer les Livres*, which Peignot describes as "plus que mediocre." In 1587 appeared the *Tableaux accomplis de tous les arts libéraux*, by Christophe de Savigny, which Brunet asserts was the model of Bacon's "Encyclopedical Tree," but which was substantially the system of Gesner. The well-known speculations of Bacon as to the genealogy of knowledge were embodied by D'Alembert in his *Discours préliminaire à l'Encyclopédie Méthodique*, Amst., 1767. They were also made the basis of other schemes by Regault-Warin, Laire, Ferraris, and especially Peignot, whose system was divided into three primitive classes, viz. history, philosophy, and imagination, with the addition of bibliography, as an introductory class. Girard's system was embodied in *l'Encyclopédie ou Dictionnaire raisonné des Sciences, des Arts, et des Métiers*, edited in 1761 by l'Érôt and d'Alembert, the latter of whom undertook the part relating to mathematics. Camus in 1798 took man in a state of nature, and then classed his library in the order in which this "man of nature" is supposed to form his impressions of the universe. The divisions of Thiébaud in 1802 comprised—(1), *Connaissances instrumentales*; (2), *Connaissances essentielles*; and (3), *Connaissances de convenances*, and were founded on a somewhat similar principle to that adopted in 1822 by the Marquis Fortia d'Urban, in his *Nouveau Système de Bibliographie alphabétique*, who prefaced his classes with

that date. A chapter of Morhof's *Polyhistor* is devoted to the same subject. See also Leibnitz, *Op. Omnia*, ed. 1768, vol. v; and Baillet's *Jugemens des Savans*. Aimé Martin's *Plan d'une Bibliothèque Universelle* appeared in 1837.

<sup>1</sup> E. Edwards, *Memoirs of Libraries*, ii. 768. See his chapter on "Classificatory Systems."

<sup>2</sup> For a full account, see the article "Gesner" by Curtis, in the *Biographie Universelle*. His *Bibliotheca* was reprinted, and greatly enlarged, by Stimler, in 1574. Conrad Lycosthenes afterwards published an abridgment, and a supplement was added by Verdier.

encyclopedias. Ampere, in 1834, in his *Essai sur la Philosophie des Sciences*, has disfigured his system with a needlessly technical nomenclature.

Much unnecessary refinement has been expended by German writers on this subject. The system of Leibnitz, however, in 1718, is well suited to practical purposes. His leading classes are these— theology, jurisprudence, medicine, intellectual philosophy, mathematics, natural philosophy, philology, history, and miscellaneous.<sup>1</sup> The scheme of the *Jena Repertorium*, published in 1793, contains 16 primitive classes, and no less than 1200 subdivisions. The system of Denis, formerly keeper of the imperial library at Vienna, was developed in his *Einführung in die Bücherkunde*, 2d edition, 1795; he classifies learning into theology, jurisprudence, philosophy, medicine, mathematics, history, and philology. Krug's system followed in 1796, and Schlieiermacher's in 1852. Wuttig's *Universal-Bibliographie*, 1862, aimed at embracing in a systematic survey the collected literature of the current time.

In England the classification of learning has been treated as a branch of philosophy rather than of bibliography. Locke's *Essay on the Human Understanding* contains, in book iv. c. 21, a "Division of the Sciences;" and Bentham has an "Essay on Nomenclature and Classification" in his *Chrestomathia*, though it does not appear that he intended it to apply to the distribution of books. Coleridge, in his *Universal Dictionary of Knowledge*, 1817, aimed at combining the advantages of a philosophical and alphabetical arrangement, and adopted four leading classes, viz.,—pure sciences, mixed sciences, history, and literature, including philology. Lord Lindsay's *Progression by Antagonism*, 1845, contains another method, based on his theory of the divisions of human thought.

For further information on this branch of the subject the reader is referred to Peignot's article on "Système" in his *Dictionnaire de Bibliologie*, and especially to the chapter on "Bibliographical Systems" in Petzholdt's *Bibliotheca Bibliographica*, Leipzig, 1866. Many of the above-named schemes, particularly those of high, philosophical pretensions, are fanciful in theory, and quite unsuited to the practical requirements of a catalogue of reference. The seven classes of Denis were based on the words of Solomon, "Wisdom hath builded a house; she hath hewn out her seven pillars;" and Naudé mentions a writer who proposed to class all sorts of books under the three heads of morals, sciences, and devotion; and who assigned, as the grounds of this arrangement, the words of the Psalmist, *Disciplinam, Bonitatem, et Scientiam doce me*. There are obvious objections to all bibliographical systems which aspire to follow the genesis and remote affinities of the different branches of knowledge. The truth is that, when bibliographers speculate in this field with a view to catalogue-making, they entirely forget their proper province and objects. The compilation of a good catalogue of an extensive library is quite difficult enough, without indulging in refined abstractions on the genealogy of human knowledge.

As regards works and collections which cannot with propriety be limited to any one division of knowledge, it would be advisable to refer them to an additional or *miscellaneous* class, as has, in fact, been done by some writers. Camus proposes to enter such works in the class in which their authors most excelled; but this plan would obviously produce much confusion. While, however, a miscellaneous class might properly indicate the collective editions of an author's works, yet his separate treatises should be entered under the subjects to which they belong. A system of cross-reference is in many cases unavoidable,

if completeness of general design is to be combined with the cardinal object of a classed catalogue, namely, that of showing what has been written by the authors specified therein on the different branches of knowledge as they may be best arranged.

#### IX. Bibliography in General.

It has been our object in this article to institute such a division of the subject, as should enable us to point out the best sources of information in regard to all its branches. Some works still remain to be noticed which treat generally of all matters relating to bibliography, though their scope and purpose differ according to the view of the science adopted by the writer. A comprehensive and judicious digest of bibliographical lore is still wanted, but there are several works which may be consulted with advantage. Cailleau's *Essai de Bibliographie*, appended to his *Dictionnaire de 1790*, is an interesting treatise. The *Einführung in die Bücherkunde* of M. Denis, 1795-96, is an excellent work divided into two parts, the first of them relating to bibliography, and the second to literary history. The *Traité Élémentaire de Bibliographie*, by S. Boulard, Paris, 1806, was intended to serve as an introduction to all works on that subject written up to the date of its appearance. The labours of Peignot, besides his works on suppressed and rare books already noticed, include—(1), the *Manuel Bibliographique, ou Essai sur la connoissance des livres, des formats, des éditions, de la manière de composer une Bibliothèque, etc.*, 1801; and (2), the *Dictionnaire raisonné de Bibliologie*, 2 vols. 8vo., 1802. The plan of this work, as Brunet admits, is well conceived, and furnishes a convenient mode of reference. Bibliography is certainly indebted to this industrious compiler, but his details have in many respects been rendered obsolete by subsequent research, and his vague notions of the scope and objects of his study have frequently led him into confusion and extravagance. A *Manuel du Bibliophile*, by the same author, appeared at Dijon in 1823. The *Cours Élémentaire de Bibliographie*, by O. F. Achard, Marseilles, 3 vols. 8vo., 1807, derives its chief value from its excellent summary of the different systems of classification applied to books. We learn from the introduction, that M. François de Neufchâteau, when Minister of the Interior, ordered the librarians of all the departments to deliver lectures on bibliography, but that the plan, which indeed appears fanciful, entirely failed, the librarians having been found quite incapable of prelecting upon their vocation. The *Introduction to the Study of Bibliography*, by Thos. Hartwell Horne, 2 vols. in 1, 8vo., London, 1814, is perhaps the most useful book of this kind in the English language, though the compiler would have done better to restrict himself to printed books, instead of ranging discursively over the whole field of MS. literature. His book is chiefly translated and compiled from French bibliographical works, and will be found useful to those who have not access to them. Besides some excellent specimens of early typography, it contains full lists of authorities on bibliography and literary history, and a copious account of libraries both British and foreign. The *Studio Bibliographico*, by Vincenzo Mortillaro, Palermo, 1832, is an Italian treatise of considerable merit. P. Namur's *Bibliographie paléographique-diplomatique-bibliologique*, Liège, 1838, embraces many subjects outside the province of bibliography proper. The *Librarian's Manual*, by Reuben A. Guild, New York, 1858, is a compendious book of reference for the student in search of authorities. Enough has been said to show that the different branches of bibliography have been treated with considerable industry; but there is room for further effort, if bibliographers will recognize the chief value of their science as the handmaid of literature. (A. F. Z.)

<sup>1</sup> Idea Leibnitiana Bibliothecæ Publicæ secundum classes scientiarum ordinanda (Works, vol. v.)

**BIBULUS.** The best-known of those who bore this surname, which belonged to the Gens Calpurnia at Rome, was Marcus Calpurnius Bibulus, elected consul with Julius Cæsar, 59 a.c. He was the candidate put forward by the aristocratic party in opposition to L. Lucretius, who was of the party of Cæsar; and bribery was freely used (with the approval, says Suetonius, of even the rigid Cato) to secure his election. But he proved no match for his able colleague. He made an attempt to oppose the agrarian law introduced by Cæsar for distributing the lands of Campania, but was overpowered and even personally ill-treated by the violence of the mob. After making vain complaints in the senate, he shut himself up in his own house during the remaining eight months of his consulship, taking no part in public business beyond fulminating edicts against Cæsar's proceedings, which only provoked an attack upon his house by a mob of Cæsar's partisans. When the interests of Cæsar and Pompey became divided, Bibulus supported the latter, and joined in proposing his election as sole consul (52 a.c.) Next year he went into Syria as proconsul, and claimed credit for a victory gained by one of his officers over the Parthians, who had invaded the province, but which took place before his own arrival in the country. After the expiration of his government there, Pompey gave him the command of his fleet in the Ionian Sea. Here also he proved himself utterly incapable; distinguishing himself chiefly by the cruel burning, with all their crews on board, of thirty transport vessels which had conveyed Cæsar from Brundisium to the coast of Epirus, and which he had captured on their return, having failed to prevent their passage. He died soon afterwards of fatigue and mortification. By his wife Portia, daughter of Cato, afterwards married to Brutus, he had three sons. The two eldest were murdered in Egypt by some of the soldiery of Gabinus; the youngest, Lucius Calpurnius Bibulus, fought on the side of the republic at the battle of Philippi, but surrendered to Antony soon afterwards, and was by him appointed to the command of his fleet. He died while governor of Syria under Augustus.

**BICHAT, MARIE-FRANÇOIS-XAVIER,** a celebrated French anatomist and physiologist, was born at Thoirette in the department of Ain, in 1771. His father, who was himself a physician, was his first instructor. He entered the College of Nantua, and afterwards studied at Lyons. In mathematics and the physical sciences he made rapid progress. Becoming passionately fond of natural history he ultimately devoted himself to the study of anatomy and surgery, under the guidance of Petit, chief surgeon to the Hôtel Dieu at Lyons. He resumed for a time his early studies, restricting himself, however, within such limits as did not interfere with his medical pursuits. Petit soon discerned the superior talents of his pupil, and, although the latter had scarcely attained the age of twenty, employed him constantly as his assistant. The revolutionary disturbances compelled Bichat to fly from Lyons and take refuge in Paris about the end of the year 1793. He there became a pupil of the celebrated surgeon Desault. One day, volunteering to supply the place of an absent pupil who was to have recapitulated the lecture of the day before, he acquitted himself so admirably that Desault was strongly impressed with his genius; and from that time Bichat became an inmate in his house, and was treated as his adopted son. For two years he actively participated in all the labours of Desault, prosecuting at the same time his own researches in anatomy and physiology. The sudden death of Desault in 1795 was a severe blow to Bichat. His first care was to acquit himself of the obligations he owed his benefactor, by contributing to the support of his widow and her son, and by conducting to a close the fourth volume of Desault's *Journal de Chirurgie*, to which

he added a biographical memoir of its author. His next object was to reunite and digest in one body the surgical doctrines which Desault had published in various periodical works. Of these he composed, in 1797, the book entitled *Œuvres Chirurgicales de Desault, ou Tableau de sa Doctrine, et de sa Pratique dans le Traitement des Maladies Extérieures*, a work in which, although he professes only to set forth the ideas of another, he develops them with the clearness and copiousness of one who is a master of the subject. He was now at liberty to pursue the full bent of his genius, and, undisturbed by the storms which agitated the political world, he directed his full attention to surgery, which it was then his design to practise. We meet with many proofs of his industry at this period in the *Recueil de la Société Médicale d'Emulation*, an association of which Bichat was one of the most active members. In 1797 he began a course of anatomical demonstrations, and his success encouraged him to extend the plan of his lectures, and boldly to announce a course of operative surgery. Bichat's reputation was now fully established, and he was ever after the favourite teacher with the Paris students. In the following year, 1798, he gave, in addition to his course on anatomy and operative surgery, a separate course of physiology. A dangerous attack of hæmoptysis interrupted for a time these heavy labours; but the danger was no sooner past than he plunged into new engagements with the same ardour as before. He had now scope in his physiological lectures for a fuller exposition of his original views on the animal economy, which excited much attention in the medical schools at Paris. Sketches of these doctrines were given by him in three papers contained in the *Memoirs of the Société Médicale d'Emulation*. The doctrines were afterwards more fully developed in his *Traité sur les Membranes*, which appeared in 1800. In the notes to a small work, in which he gave in a condensed form the lessons of Desault on the diseases of the urinary passages, are found the germs of many of Bichat's peculiar views.

His next publication was the *Récherches Physiologiques sur la Vie et sur la Mort* (1800), which consists of two dissertations. In the first he explains his classification of functions, and traces the distinction between the animal and organic functions in all its bearings. In the second he investigates the connection between life and the actions of the three central organs, the heart, lungs, and brain. But the work which contains the fruits of his most profound and original researches is the *Anatomie Générale*, published in 4 vols. 8vo in 1801.

Before Bichat had attained the age of eight-and-twenty he was appointed physician to the Hôtel Dieu, a situation which opened an immense field to his ardent spirit of inquiry. In the investigation of diseases he pursued the same method of observation and experiment which had characterized his researches in physiology. He learned their history by studying them at the bedside of his patients, and by accurate dissection of their bodies after death. He engaged in a series of examinations, with a view to ascertain the changes induced in the various organs by disease, and in less than six months he had opened above six hundred bodies. He was anxious also to determine, with more precision than had been attempted before, the effects of remedial agents, and instituted with this view a series of direct experiments on a very extensive scale. In this way he procured a vast store of valuable materials for his course of lectures on the *Materia Medica*, the completion of which was prevented by his death; but a great part of the facts were embodied in the inaugural dissertations of his pupils. Latterly, he also occupied himself with forming a new classification of diseases.

Bichat commenced a new work on anatomy, in which



the organs were arranged according to his peculiar classification of their functions, under the title of *Anatomic Descriptive*, but he lived only to publish the first two volumes. It was continued on the same plan, and completed in five volumes by his assistants MM. Buisson and Roux. His death was occasioned by a fall from a staircase at the Hôtel Dieu, which threw him into a fever. Exhausted by excessive labour, and enfeebled by constantly breathing the tainted air of the dissecting-room, he sank under the attack and died on the 22d July 1802, attended to the last by the widow of his benefactor, from whom he had never been separated. His funeral was attended by above six hundred of his pupils, and by a large number of the physicians of Paris. His bust, together with that of Desault, was placed in the Hôtel Dieu by order of Napoleon.

**BICYCLE.** As the derivation of the term implies, the chief component parts of this machine consist of two wheels. The word is applied to those two-wheeled machines which have been brought to their present state of perfection for human locomotion during the past five years. Shortly after the close of the great Continental war in 1815, the first bicycle was introduced into England from France. It was at the best an awkward affair, composed of a couple of heavy wooden wheels of equal diameter, one behind the other, and joined together by a longitudinal wooden bar on which the rider's seat was fixed, the mode of propulsion being the pushing the feet against the ground. That such a cumbersome method of locomotion soon died a natural death is not to be wondered at. For the next fifty years no real progress was made, as various kinds of levers and other attempted appliances were found too intricate. In 1869 M. Michaux of Paris conceived the idea of making the front or driving wheel much larger than the hind wheel; and very soon afterwards, M. Magee, another Parisian, still further improved bicycles by making them entirely of steel and iron. The principle of crank action attached to revolving axles having also become developed, the pastime of bicycling was entirely revolutionized. India-rubber tyres and strong beaks were brought into requisition to relieve jolting; and now-a-days a crack racing bicycle with a driving-wheel from 55 to 60 inches diameter does not exceed 50 lb in weight, or about half the weight of one of the old wooden machines. Tricycles have been tried, but no great amount of speed will ever be got out of them until the friction and weight can be materially reduced.

The diameter of the front or driving wheel of the modern bicycle varies from 2½ to 5 feet, according to the length of the rider's legs. When it is meant for racing, most of the component parts are lighter, and the rest for relieving the legs when going down hill is dispensed with. The rider sits astride a small saddle, and the motive power is obtained from the feet working the crank treadles attached to the revolving axle of the driving-wheel. There being no lateral support to the machine, the first thing to be learnt is balancing, after which it is best to begin riding down a gentle gradient without using the treadles. Steering, which is managed by a transverse handle attached to the driving-wheel and placed in front of the rider, should be mastered in the same manner, after which the feet and legs may be brought into play on the treadles and speed gradually acquired. Falls are inevitable at first, and they are best avoided by slightly turning the driving-wheel in the direction the machine is inclining, not the contrary way. Care must be taken to keep all bearings, &c., oiled from time to time, in order to prevent friction and so lessen speed. With the exception of skating, bicycling is the quickest means of locomotion that man possesses. A fair bicyclist can outstrip a horse in a day, whilst an expert can do so in an hour. Bicycling has rapidly grown in favour during the past two years; and long tours are

now made with the greatest ease. Where the roads are fairly level, and in a tolerably good state of repair, the bicycle is unsurpassed as a means of self-locomotion. In hilly and mountainous countries, where there are no made roads, or where they are much broken up and heavy, it is next to useless, although india-rubber tyres to a certain extent relieve the jolting over rough ground. Lightness, great strength, and the best of workmanship are necessary in the manufacture of bicycles in order to prevent serious accidents. It is in the two former requisites that steel and india-rubber have such an advantage over iron and wood.

As a proof of the perfection to which bicycle-riding has now been brought, the following best performances on record, over a prepared cinder path, may be mentioned, viz. —

Miles.	Hours.	Min.	Sec.	Miles.	Hours.	Min.	Sec.
1	0	1	32½	10	0	34	41
1	0	2	19½	20	1	12	38
1	0	3	0	30	1	52	48
2	0	6	31	40	2	31	48
3	0	9	58	50	3	9	21
4	0	13	19½	60	4	11	24
5	0	16	41	70	4	56	35
6	0	20	55	80	5	46	48
7	0	24	28	90	6	42	21
8	0	28	5	100	7	38	48
9	0	31	2	106	7	58	54½

The last of these, as one of the London daily journals remarked, fairly ranks as "the most extraordinary performance on record of any man, animal, or machine." The distance from Tunbridge to Liverpool, 234 miles, has been accomplished in 18 hours 35 minutes. A hundred miles a day, over fair roads, has often been achieved for several days together, and many such journeys are recorded. A ride of 800 miles, from London to John O'Groats, was made in 14 days, over unexceptionally hilly and heavy roads, in June 1873.

**BIDA**, an inland town of Africa, situated in about N. lat. 9° 5' and E. long. 6° 5', sixteen miles N. of the River Niger or Quorra, and lying N.N.W. of the town of Egga. Bida, which was visited by Dr Baikie in 1862, is a large town, the capital of the kingdom of Nupe.

**BIDDLE, JOHN**, frequently called the father of English Unitarianism, was born in 1615 at Wotton-under-Edge in Gloucestershire. He was educated at the grammar school of his native town, and then proceeded to Magdalen Hall, Oxford. He graduated as bachelor of arts in 1638 and as master in 1641, and was then appointed to the mastership of the free school in the city of Gloucester. While conducting this school in an admirable manner he diligently prosecuted his theological studies; and the results he arrived at were of such a nature as to draw down upon him the reprobation of the civic authorities. He circulated privately a tract called *Twelve Arguments drawn out of Scripture, wherein the commonly received opinion touching the deity of the Holy Spirit is clearly and fully refuted*; and towards the close of 1645 he was summoned before the Parliamentary committee then sitting at Gloucester. By them he was committed to prison, though he was at the time labouring under a dangerous fever. He was released on bail after an imprisonment of some duration, and was then called before the Parliament, which desired to inquire into his views. After tedious proceedings Biddle was committed to custody, in which he remained for five years. During that time the Assembly of Divines at Westminster had discussed his opinions, and in defence he published his *Twelve Arguments*. The book was at once ordered by Parliament to be seized and burned by the hangman. Notwithstanding this, Biddle issued two tracts, one a *Confession of Faith with regard to the Holy Trinity*, the other *Testimonies of Irenæus, &c., concerning the one God and the Persons of the Holy Trinity*. These were suppressed by Government, and the Assembly of Divines eagerly pressed for the passing of an Act by which heretics like Biddle could be put to death. This, however, was resisted by the army, and by many of the Independent Parliamentarians; and after the death of the king, Biddle

was allowed to reside in Staffordshire under surveillance. In 1651 the general Act of Oblivion gave him complete freedom, and his adherents soon began the practice of meeting regularly for worship on Sundays. They were called Biddellians, or Socinians, or Unitarians, the name which has now become associated with their opinions. Biddle was not left long in peace. He translated some Socinian books, among others the *Life of Socinus*, and published two catechisms, which excited a fury of indignation against him. He was summoned before the Parliament and imprisoned. The dissolution of that body again set him at liberty for a short time, but he was presently brought up for some expressions used by him in a discussion with a Baptist clergyman. He was put upon trial, and was only rescued by Cromwell, who sent him out of the way to one of the Scilly Islands, and after three years released him. But in 1662 he was again arrested, and fined £100. As he was unable to pay this sum, he was at once committed to prison, where fever, caused by the pestilential atmosphere, carried him off on the 22d September 1662.

BIDEFORD, a municipal borough, market-town, and seaport, in the county of Devon, eight miles S.W. of Barnstaple, with which it is connected by railway. It is situated on the slopes of two hills which rise from the banks of the River Torridge, near its confluence with the Taw, about four miles from the sea. The two portions of the town are united by a bridge of fourteen arches, built, it is said, in the 14th century, and widened in 1864. The bridge forms a favourite promenade, and is endowed for its repair with lands that produce an annual rent of £300 or £400. Many of the houses in the town are built in the ancient fashion with bricks and wooden framework. The old church of St Mary, with the exception of the tower, was taken down and rebuilt in 1864, and the town-hall is also of modern erection. In addition to these buildings Bideford possesses several large churches and schools, a union workhouse, assembly-rooms, a hospital for aged poor, a reading-room, and a literary and scientific institution. Bideford was already a place of some size under the Saxons, received the right of holding a market in 1271, and was made a free borough in 1573. In the 16th and 17th centuries it was a place of great trade, and in some respects was only exceeded by Exeter and London. The weaving of silk was introduced in 1650, and after the revocation of the Edict of Nantes received extensive development from some French refugees. Bideford now manufactures earthen wares, ropes, sails, and leather, builds ships, and has a considerable trade both domestic and foreign. Vessels of 500 tons can come up to its quay. It exports oak-bark, grain, and its own manufactures, and imports timber from Canada and the Baltic, with fruits, wines, and brandies from the south of Europe. The value of its imports was, in 1873, £13,310. Anthracite, coarse potters' clay, and a mineral paint are found in the neighbourhood. Population of municipal borough in 1871, 6969.

BIDPAI, more commonly known under the corrupted name of Pilpay, is the supposed author of a famous collection of Hindu fables. Nothing is known of Bidpai beyond the name, which, indeed, occurs only in the Arabic version, but the history of the collection of stories is curious and interesting. The origin of them is undoubtedly to be found in the *Pancha Tantra*, or Five Sections, an extensive body of fables or apologues. A second collection, called the *Hitopadesa*, has become more widely known in Europe than the first, on which it is apparently founded. In the 6th century A.D., a translation into Pehlvi of a number of these old fables was made by Barzuyeh, a physician at the court of Nushirvan, king of Persia. No traces

of this Persian translation can now be found, but nearly two centuries later, Abdallah-ibn-Mokaffah translated the Persian into Arabic; and his version, which is known as the "Book of Kalilah and Dimna," from the two jacks in the first story, became the channel through which a knowledge of the fables was transmitted to Europe. It was translated into Greek by Simeon Sethus towards the close of the 11th century; his version, however, does not appear to have been retranslated into any other European language. But the Hebrew version of Rabbi Joel, made somewhat later, was translated into Latin by John of Capua, and in that form became widely known. Since then the fables have been translated into nearly every European tongue. There are also versions of them in the modern Persian, Malay, Mongol, and Afghan languages.

See Wilson's analysis of the *Pancha Tantra*, in the *Mss. of the Royal Asiatic Soc.*, i.; De Saoy's introduction to his edition of the *Kalilah and Dimna*, 1816; articles by the same in *Notices et Extr. des MSS. de la Bib. du Roi*, vols. ix. and x.; Wolf, *Bidpai's Fables*, 2 vols. 1837; Loiseleur des Longchamps, *Essai sur les Fables Indiennes*, 1838; Bealey, *Pancha Tantra*, 2 vols. 1859.

BIEL (or in French *Bienheim*), a town of the canton of Bern, in Switzerland, situated at the foot of the Jura Mountains, near the northern end of the lake to which it gives its name. It is well built, and possesses a town-house of some antiquity, a remarkable church, a hospital, a gymnasium, and an industrial school. There is considerable industrial activity in Biel, especially in the manufacture of cotton, leather, iron wire, and watches. Founded in the 11th or 12th century, Biel continued under the authority of the bishopric of Basel till the beginning of the 15th, when it formed an alliance with Bern, Solothurn, and Freiburg. Its defence against the French in 1798 is commemorated by an obelisk on a neighbouring eminence. Its incorporation with Basel dates from 1815. Population, 8113.

BIEL, GABRIEL, frequently but erroneously styled the last of the scholastics, was born at Spire about the middle of the 15th century. He held for some time a pastoral charge at Mainz, and afterwards removed to Urach. On the foundation of the University of Tübingen in 1477 he was appointed to the professorship of theology, and was twice afterwards promoted to the dignity of rector. Some years before his death, in 1495, he entered a religious fraternity. Biel was a follower of William of Ockam, and professes only to develop systematically the principles of his master. His great work, *Collectorium super Libros Sententiarum G. Occami* (1508, 1512, and various dates), is an admirably clear and consistent account of the nominalist doctrine, and presents the complete system of scholastic thought regarded from that point of view. The strong empirical individualism of the work, tending necessarily to limit the province of reason and extend that of faith, together with scattered utterances on special points, which gained for Biel the title of *Papista Antipapista*, had considerable influence in giving form to the new doctrines of Luther and Melancthon. From its lucidity and relative completeness Biel's work is the best specimen of the final aspect of scholasticism. His other works have also been frequently reprinted. With regard to the title *Ulmsen Scholasticorum*, often bestowed on Biel, it has been pointed out by all the best authorities that such a designation is quite inappropriate; scholasticism did not cease even in Germany with Biel, and it continued to flourish long after his time in the universities of Spain. (*Stöckl, Phil. d. Mittelalt.*, ii. § 269; Roscher, *Ges. d. Nationalökonomik*, pp. 21-28.)

BIELAU, frequently distinguished as Langen Biela, the longest village in the Prussian monarchy. It is situated in the government of Breslau in Silesia, on a tributary of the Piela, and extends for a distance of rather more than four miles. Its industrial establishments are numerous

and important, the cotton manufactory alone employing 2000 looms; while bleaching, dyeing, printing, tile-making, and sugar-refining are all extensively carried on. There is an old castle in the village belonging to Count Sandreczky. Population in 1871, 13,070.

**BIELAYA TSEKOV** (i.e., White Church), a township of Russia, in the government of Kieff, 32 miles S.S.W. of Vasilko, on the main road from Kieff to the Crimea, in 49° 47' N. lat. and 30° 7' E. long. First mentioned in 1155, Bielaya Tserkov was destroyed during the Mongolian invasion, but afterwards recovered its prosperity. In 1550 a castle was built in the town by Prince Prunaky, waiwode of Keiff, and various immunities were bestowed on the inhabitants. A Polish army occupied the place in 1651, and from that time it was alternately subject to Poland and to independent hetmans. In 1774 it received a charter from Stanislas Augustus, and in 1793 was united to Russia. The principal buildings of Bielaya Tserkov include two Greek churches, one Roman Catholic church, two synagogues, a hospital, and a gymnasium (founded in 1846). In commercial activity the town only yields to Kieff, Berdicheff, and Uman—the chief articles of trade being cattle and grain. There are eleven annual fairs, three of which last for ten days each. The sales at these fairs amount to upwards of £28,000. Population in 1860, 12,075, of whom 7349 are Jews.

**BIELEFELD**, a town in the Prussian province of Westphalia, the capital of a circle in the government of Minden. It is situated at the foot of the Osnig, and consists of two portions, separated by the River Lutser, which were first united into one town in 1520. Among its public buildings and institutions are the old town church, with a curious carved altar piece, the town-house, the gymnasium, and the provincial industrial school. On the height above the town is the old castle of Sparrenberg, for a long time employed as a prison. It was founded about the 12th century, and originally bore the name of Löwenberg. Bielefeld is the centre of the Westphalian linen trade, and contains extensive factories and bleachfields. The Ravensberg factory has upwards of 24,000 spindles, and the Vorwärts, 10,700. Tobacco, glass, cement, cast-iron, leather, tiles, &c., are also manufactured in the town. Bielefeld is mentioned as early as the 9th century, as *Belanvelde*, and rose into importance in the 11th or 12th as the capital of the countship of Ravensburg. It joined the Hanseatic league in 1270, and about the same time began to engage in the linen manufacture, which was greatly extended during the 16th and 17th centuries by a number of refugees from the Netherlands. In 1666 the town passed with the countship to the duchy of Brandenburg. Population in 1871, 21,834.

**BIELEFF**, a town of Russia, in the government of Tula, and 82 miles from that city, on the left bank of the Oka, in 53° 48' N. lat. and 35° 9' E. long. It is first mentioned in 1147; it belonged to Lithuania in the end of the 14th century; and in 1468 it was raised to the rank of a principality, dependent on that country, by Basil Romanovitch, who had come thither from Odosoff. In the end of the 15th century this principality began to separate from Lithuania and attach itself to the Grand Duchy of Moscow; and by the peaceful treaty of Ivan III. with Alexander the Lithuanian Bieleff was ultimately united to Russia. In the 16th century it suffered greatly from the Tatars, especially in the years 1507, 1512, 1530, 1536, and 1544. In 1538 Ivan the Terrible exiled Prince John of Bieleff to Vologda, and in 1565 declared the lordship his own property. In 1607 Nikivitch Romanoff, general of the Emperor Basil Ivanovitch, gained a complete victory in the neighbourhood against the rebellious Prince Mosalsky. Transferred in 1708 from the Smolenak to the Kievan government, Bieleff passed

in 1719 to the Bielgorod district of Orloff, and in 1777 was made a departmental town of the government of Tula. In 1826 the Empress Elizabeth Alexievna died in Bieleff on her way from Taganrog to St Petersburg. The buildings of the town include nineteen churches and two monasteries, a hospital, a widow's asylum, a foundling institution, an almshouse, a prison, and a theatre. A public library was founded in 1858 in memory of Basil Zhukovsky, who was born in a neighbouring village. The industrial establishments comprise tallow-boiling premises, oil manufactories, a tannery, a sugar-refinery, a distillery, &c. In extent of trade Bieleff ranks next in the government to Tula—the most important articles being grain, hemp, oil, and tallow. A great fair is held from the 28th of August to the 10th of September. The population in 1860 was 8063, by far the greater proportion belonging to the Greek Church.

**BIELGOROD** (i.e., White Town), a town of Russia, in the government of Kurak, 87 miles S.S.W. from that city, in 50° 36' N. lat. and 36° 37' E. long., on the right bank of the North Donets, near the confluence of the Vizelka. It occupies a high chalk hill, from which are annually quarried about 112 tons. The date of the founding of Bielgorod is uncertain, because it has been confounded with two other places of the same name. In Karamsin's *History* it is mentioned that the Grand Duke Theodore Ivanovitch in 1593 sent to found Bielgorod on the ruins of Siever; and it is certain that ancient remains are still to be seen in this city. In the 17th century Bielgorod suffered ceaselessly from Tatar incursions, against which, by command of the Emperor Michael Theodorovitch, there was built (from 1633 to 1740) an earthen wall, with twelve forts, extending upwards of 200 miles from the Vorakla to the Don. These defences were called the Bielgorod line, along which, in the reign of Alexias Michaelovitch, there were settled emigrants from Cherkas, Zimbar, Corsun, and elsewhere. In 1666 an episcopal see was established in the town, and the archbishops lived there till 1833, when they were transferred to Kurak. In 1779 Bielgorod was made the chief town of a circle in the Kurak government. There are two cathedral churches in the place, Trinity and Assumption, both built in the 16th century, as well as fifteen other churches, two monasteries, a theological seminary, an almshouse, and a hospital. In 1862 a bank was established with a capital of between £10,000 and £15,000. Only a few of the houses are built of stone. Wax-candles, tallow-candles, leather, soap, and bricks are manufactured, and a considerable trade is carried on in grain and cattle. There are three annual fairs on the 10th Friday after Easter, the 29th June, and 15th August respectively. Population in 1860, 11,722, almost all belonging to the Greek Church.

**BIELITZ**, a town of Austrian Silesia, in the circle of Teschen, on the Biala River, a sub-tributary of the Vistula, and opposite the Galician town of Biala, with which it is connected by a bridge. It is the seat of the superintendent of all the Protestants in Moravia, and the residence of the Sulkowsky family, in favour of whom the lordship of Bielitz was raised to a duchy in 1754. The castle is a fine building of some antiquity, surrounded by a beautiful park. The principal industries of the town are the spinning of flax and the printing and dyeing of cloth, the last especially being carried on with great success. A valuable traffic is maintained not only in the produce of the factories but also in Hungarian wine and Galician salt. The town was founded in the 13th century, and in the 15th and 16th was a fortified place. It is connected by means of a branch line with the Kaiser Ferdinand Northern Railway. Population in 1869, 10,721.

**BIELLA**, a town of Italy, in the province of Novara, 38 miles N.E. of Turin, with which it is connected by rail. It is built partly on the slope of a hill and partly on the

banks of two small streams called the Cervo and Aurena,—the palatial old houses of the upper portion being now inhabited by the poorer classes. Several of the streets have arcades along the sides. It is the seat of a bishop, and has a cathedral, an episcopal palace, and a theological seminary. The principal industries are the manufacture of cloth and paper, and the trade consists mainly in oil, chestnuts, and silk. Population in 1870, 11,935.

**BIELOPOLI**, a town of Russia in the government of Kharkoff, near the Vuira and Kriuga, 37 miles N.W. from the town of Sum, in 51° 9' N. lat., and 34° 19' E. long. It was founded in 1672. A very extensive trade in wheat, salted fish, salt, pitch, and timber is carried on by the inhabitants, who number upwards of 12,000.

**BIELOSTOK** (in Polish **BIALYSTOK**), a town of Russia, in the government of Grodno, in 53° 5' N. lat. and 23° 9' E. long., 50 miles S.W. of Grodno on the River Biela, a tributary of the Suprasla. Founded in the 14th century it was long an important proprietary village belonging to the Veselovskia. In the 17th century it passed to the Branetakis, at whose solicitation Augustus III., in 1749, raised it to the rank of a borough and gave it civic rights. This increased its prosperity, and after the third partition of Poland in 1793, the Prussian Government, to whom it had been assigned, made it the seat of an administrative department. By the peace of Tilsit in 1807, Bieloostok was given to Russia along with the department of the same name, which in 1808 was divided into the four districts of Bieloostok, Bielsk, Sokol, and Drogotchin. The public buildings of Bieloostok comprise a Greek and a Roman Catholic church, several synagogues, a hospital, a castle (used as a prison), a gymnasium, an institution for the daughters of the nobility, and various other schools. There are three cloth factories and an extensive brewery; cotton and wool-spinning are both carried on, and leather, oil, soap, and tallow are manufactured. There is also an important trade in grain, wood, and various industrial articles. In 1860 the population was 16,544, no fewer than 11,288 being Jews.

**BIENHOA**, the capital of one of the six provinces of Lower Cochinchina, situated about 20 miles to the north-west of Saigon, on a canal that connects it with that city. It was captured by the French admiral Bonard in 1861, and is now one of the fortified posts in the French possessions. Sugar-mills were started in 1869 by an English company; but, owing to the jealousy of the Anamites, they had soon to be closed. The population of the "Inspection" of Bienhoa is 19,260.

**BIEZHETZ**, a town of Russia, in the government of Tver, and 181 miles from that city, situated on the right bank of the Mologa, in 57° 46' N. lat. and 36° 45' E. long. On the left bank of the river lies the suburban village of Shtap, chiefly inhabited by the lower orders. Biezhetz is mentioned in the chronicles of 1137. On the fall of Novgorod, to which it had belonged, it was incorporated with the grand-duchy of Moscow; and in 1771 it was added to the government of Tver. Candles, leather, brandy, beer, flour, malt, oil, and bricks are all manufactured; but a more important branch of industry is the making of bags for grain and flour. There are two weekly markets and two annual fairs. Population in 1860, 5423.

**BIGAMY**, according to the statute now in force (24 and 25 Vict. c. 100, § 57), is the offence committed by a person who "being married shall marry any other person during the life of the former husband or wife." In the canon law the word had a rather wider meaning, and the marriage of a widow came within its scope. At the Council of Lyons (1274 A.D.) bigamists were stripped of their privilege of clergy. This canon was adopted and explained by the English statute 4 Edward I. st. 3, c. 5; and bigamy, there-

fore, became a usual counterplea to the claim of *benefit of clergy*. However, by 1 Edward VI. c. 12, § 16, every person entitled to the benefit of clergy is to be allowed the same, "although he hath been divers times married to any single woman or single women, or to any widow or widows, or to two wives or more." A bigamous marriage, by the ecclesiastical law of England, is simply void. By the statute 1 James I. c. 11, confirmed by later statutes, the offence was made a felony. It is immaterial whether the second marriage has taken place within England and Ireland or elsewhere, and the offence may be dealt with in any county or place where the defendant shall be apprehended or be in custody. The following clause embodies the necessary exceptions to the very general language used in the definition of the offence:—"Provided that nothing in this section contained shall extend to any second marriage contracted elsewhere than in England and Ireland by any other than a subject of Her Majesty, or to any person marrying a second time whose husband or wife shall have been continuously absent from such person for the space of seven years then last past, and shall not have been known by such person to be living within that time, or shall extend to any person who at the time of such second marriage shall have been divorced from the bond of the first marriage, or to any person whose former marriage shall have been declared void by any court of competent jurisdiction." The punishment is penal servitude for not more than seven nor less than five years, or imprisonment with or without hard labour, not exceeding two years. A valid marriage must be proved in the first instance in order to support a charge of bigamy. A *voidable* marriage, such as were marriages between persons within the prohibited degrees before 5 and 6 Will. IV. c. 54, will be sufficient, but a marriage which is absolutely *void*, as all such marriages now are, will not. For example, if a woman marry B during the lifetime of her husband A, and after A's death marry C during the lifetime of B, her marriage with C is not bigamous, because her marriage with B was a nullity. In regard to the second marriage (which constitutes the offence) the English courts have held that it is immaterial whether, but for the bigamy, it would have been a valid marriage or not. An uncle, for example, cannot marry his niece; but if being already married he goes through the ceremony of marriage with her he is guilty of bigamy. In an Irish case, however, it has been held that to constitute the offence the second marriage must be one which, but for the existence of the former marriage, would have been valid. With reference to the case in which the parties to the first marriage have been divorced, it may be observed that no sentence or act of any foreign country can dissolve an English marriage *a vinculo* for grounds on which it is not liable to be dissolved *a vinculo* in England (R. v. Lolley, in Russell and Ryan's *Criminal Cases*, 237). Hence, a divorce *a vinculo* for adultery, in a Scotch court, of persons married in England is not within the statute.

In Scotland, at the date of the only statute respecting bigamy, that of 1551, cap. 19, the offence seems to have been chiefly considered in a religious point of view, as a sort of perjury, or violation of the solemn vow or oath which was then used in contracting marriage; and, accordingly, it was ordained to be punished with the proper pains of perjury. But this injunction has not in every instance been complied with; and, from considerations of policy or expediency, the court has long been in the habit of inflicting an arbitrary punishment, suited, as nearly as may be, to the degree of guilt brought home to the prisoner. Neither marriage need be regular, but it is not yet settled whether a marriage constituted by habit and repute, or by promise *subsequente copula*, can be relevantly libelled as a

charge of bigamy. The parties to the first marriage must, of course, have been lawfully entitled to marry. It is a good defence that the accused was divorced from his first wife before contracting the second marriage, even though the decree should afterwards have been set aside, unless it has been obtained corruptly and set aside for that reason. It is also a good defence that, at the time of contracting the second marriage, the accused had reasonable grounds for believing the other spouse to be dead. To constitute the crime of bigamy, it is not necessary that the second marriage should be such that, but for the first marriage, it would have been legal. The punishment is imprisonment, and occasionally penal servitude.

BIGNON, JEROME, a French lawyer, was born at Paris in 1589. He was uncommonly precocious, and under his father's tuition had acquired an immense mass of knowledge before he was ten years of age. In 1600 was published a work by him entitled *Chorographia, ou Description de la Terre Sainte*. The great reputation gained by this book introduced the author to Henry IV., who placed him for some time as a companion to the duke of Vendôme, and afterwards made him tutor to the Dauphin. In 1604 he wrote his *Discours on the City of Rome*, and in the following year his *Summary Treatise on the Election of the Pope*. He then devoted himself to the study of law, wrote in 1610 a treatise on the precedency of the kings of France, which gave great satisfaction to Henry IV., and in 1613 edited, with learned notes, the *Formulae* of the jurist Marculte. In 1620 he was made advocate-general to the grand council, and shortly afterwards a councillor of state, and in 1626 he became advocate-general to the parliament of Paris. In 1641 he resigned his official dignity, and in 1642 was appointed by Richelieu to the charge of the royal library. He died in 1656.

BIGORDI, DOMENICO. See GHIRLANDAIO.

BIJAINAGAR, or BIJANAGAR, an ancient city in the south of India, once the capital of a great Hindu empire, but now in ruins, situated on the south bank of the Tumbhadra River, directly opposite to Annagundi, in 15° 19' N. lat. and 76° 32' E. long. The city has been enclosed with strong stone walls on the east side, and is bounded by the river on the west, the circumference of the whole appearing to be about eight miles. The streets of this city, from 30 to 40 yards wide, can be traced between the immense piles of rocks crowned with pagodas; and one street yet remains perfect. The building of this metropolis was begun in 1336. Between the kings of the principality, of which it was the capital, and the Mahometan sovereigns of the Deccan constant hostility was maintained. In 1564 Rám Rájá, the king of Bijainagar, was totally overthrown on the plains of Telikotá, by a combination of the four Mahometan sovereigns of the Deccan, who immediately marched to the metropolis, which they abandoned to pillage. From that time it has lain in ruins.

BIJAPUR, or BIJAAPUR, in Southern India, the ancient capital of an independent sovereignty of the same name, and once an extensive, splendid, and opulent city, but now retaining only the vestiges of its former grandeur. It is situated in a fertile plain, in 16° 50' N. lat. and 75° 48' E. long., and is a place of great extent, consisting of three distinct portions—the citadel, the fort, and the remains of the city. The citadel, a mile in circuit, is a place of great strength, well built of the most massive materials, and encompassed by a ditch 100 yards wide, formerly supplied with water, but now nearly filled up with rubbish, so that its original depth cannot be discovered. It was built in 1489, by Yusuf Adil Sháh, the founder of the dynasty of Bijápur. The fort consists of a rampart flanked by numerous towers, a ditch, and a covered way. Its defences, which are not less than six miles in circumference, were completed by Ali

Adil Sháh in 1566. The interior formerly contained the king's palace, the houses of the nobility, large magazines, and extensive gardens. At present, though considerable portions of the area are covered with buildings or ruins, there is room set aside for corn-fields and extensive enclosures. Outside the fort are remains of a vast city, now for the most part in ruins, but the innumerable tombs, mosquer., caravanserais, and other edifices, which have resisted the havoc of time, afford abundant evidence of the ancient splendour of the place. It is asserted by the natives that Bijápur contained, according to authentic records, 1600 mosques and nearly 1,000,000 houses. The number of houses is certainly overrated; that of the mosques, in the opinion of recent travellers, is no exaggeration. The outer wall of the city on the western side runs nearly south and north, and is of great extent. It is built of stone, is of prodigious thickness, and is about 20 feet in height, with a ditch and rampart; and at intervals of 100 yards are capacious towers, built of large hewn stones. The whole is now in a ruinous condition,—the wall and the towers hanging in many places fallen into the ditch, and in other parts being covered with rubbish. Several mosques and mausoleums, adorned with all the embellishments of Eastern architecture, are still to be seen in Bijápur. The fort in the interior is adorned with many of these edifices, in rather better preservation than the outworks. Among these is the great mesque, which is 97 yards long by 55 broad. The wings, which are 15 yards broad, project 73 yards from the north and south ends, enclosing on three sides, with the body of the mosque, a large reservoir of water and a fountain. The mausoleum of Sultan Muhammad Sháh is a plain building, 153 feet square, over which is reared a dome 117 feet in diameter at its greatest concavity, and called by the natives the grand cupola. The mosque and mausoleum of Ibrahim Adil Sháh, king of Bijápur, which was probably completed about the year 1620, is said to have cost £1,700,000, and to have occupied thirty-six years in its construction. It is built on a basement 130 yards in length by 52 in breadth, and raised 15 feet. On this is a plain building, 115 feet by 76, covered by an immense dome raised on arches. The mausoleum is a room 57 feet square, enclosed by two verandahs, 13 feet in breadth and 22 feet in height. There are, besides, many other public buildings more or less injured by time and the violence of the Marhattás. Almost all the buildings, the palaces of the fort excepted, are of massive stone, and in the most durable style; and at the same time the workmanship is minutely elegant. Among the curiosities of the capital is the celebrated monster gun, stated to be the largest piece of cast brass ordnance in the world. It was captured from the king of Ahmádnagar by the king of Bijápur about the middle of the 17th century. An inscription on the gun recording that fact was erased by Aurangzeb, who substituted the present inscription, stating that he conquered Bijápur in 1685. The city is well watered, having, besides numerous wells, several rivulets running through it.

After the dissolution of the great Báhmáni dynasty of the Deccan in 1489, a race of independent sovereigns arose, who ruled over the new kingdom of Bijápur, extending on the east from the confluence of the Bhímá and the Krishná to the sea-coast, on the west from Goa to Bombay. Their rule endured through several generations, until at length, in 1650, Sháh Jahán compelled them to become tributary to the empire; and shortly after, their monarchy was totally subverted by his successor Aurangzeb. The city and territory of Bijápur remained annexed to Delhi till 1724, when the Nisám established his independence in the Deccan, and included Bijápur within his dominions. His sway over this portion of his acquisitions, was, however, of brief duration; for, being defeated by the Peshwá

in 1760, he was constrained to purchase peace by its cession to the Marhattas. Upon the fall of the Peshwá in 1818, Bijápur passed into the hands of the British, and was by them included in the territory assigned to the Rájá of Satára.

The place, as already intimated, is rich in monuments of the bygone period when Bijápur was the capital of a powerful and flourishing Mahometan kingdom. Such traces of the past it is always desirable to preserve to the greatest possible extent, as they furnish the best commentary upon the history of the times in which they were raised, and, indeed, constitute their history, so far as manners are concerned. It is fortunate that their value was duly appreciated by the late Rájá of Satára, who took great pains to preserve them; and that the British Government, participating in the same feeling, has, since the country passed into its possession, manifested great zeal in rescuing these magnificent relics from the ravages of time. Bijápur is distant 130 miles S.E. of Satára, and 245 S.E. of Bombay.

BIJNAUR, a district of British India, under the Lieutenant-Governor of the North-West Provinces, lying between 29° 1' and 29° 58' N. lat., and 78° 1' and 78° 55' E. long., is bounded on the N.E. by the British district of Garhwal, on the E. and S.E. by the British district of Morádábád, and on the W. by the British districts of Mirat, Muzaffarnagar, and Saháranpur. The aspect of the country is generally a level plain, but the northern part of it rises towards the Himálays, the greatest elevation being 1342 feet above the sea-level. The Koh and Rámgrahá are the only streams that flow through the district.

Population in 1872, 737,152 souls, inhabiting 158,583 houses, and 5002 villages or townships. Area of the district, 1902 square miles; persons per square mile, 388; per village, 368; and per house, 4.6. The Hindus numbered 498,601, or 67 per cent of the total population; Mahometans, 243,455, or 33 per cent; and Christians and others of unspecified religions, 96 souls. Of the area of the district (namely, 1902.94 square miles), 1086.14 square miles are under cultivation; 432.63 square miles cultivable, but not actually under cultivation; and the remainder uncultivable waste. Principal crops:—Sugar-cane, cotton, rice, pulses, oil-seeds, and different kinds of millet. Principal lines of road:—(1.) Najfbábád to Hardwár and Srinagar; (2.) Mirat to Bijnaur, Kíratpur, and Najfbábád; (3.) Bijnaur to Nagíná and Barápur; (4.) Najfbábád to Nagíná, Nahtaur, Chándpur, and Bahtá; (5.) Morádábád to Sahorá, Nagíná, and Najfbábád; and (6.) Núrpur to Dhámpur, Sherkot, and Afzalgaah, on to Kálgah. In 1870-71, the total revenue of Bijnaur district amounted to £148,958, of which £127,316, or 85 per cent, was derived from land. For the protection of person and property, a regular police force of 486 strong is maintained, exclusive of the village watch. In 1872-73, Bijnaur district contained 334 schools, attended by 5819 pupils. The following thirteen towns contain a population exceeding 5000 souls:—(1.) Bijnaur, the headquarters town of the district, in 29° 29' 36" N. lat. and 70° 10' 30" E. long.; population, 12,865; municipal income in 1872, £1040, 16s.; expenditure, £681, 8s.; rate of taxation, 1s. 7½d. per head: (2.) Siohárá, population, 8340; municipal income, £94, 18s. 4d.; expenditure, £83, 8s. 6d.; (3.) Sáháspur, population, 6309; not a municipal town: (4.) Najfbábád, population, 17,418; municipal revenue, £1584, 4s.; expenditure, £1425, 16s.; (5.) Shírkot, population, 12,586; municipal revenue, £178, 14s. 5d.; expenditure, £130, 17s. 4d.; (6.) Dhámpur, population, 6555; municipal revenue, £321, 10s.; expenditure, £229, 12s.; (7.) Mandáwar, population, 7622; municipal revenue, £86, 19s. 3d.; expenditure, £116, 13s. 8d.; (8.) Afzalgaah, population, 8350; municipal revenue, £100, 1s. 1d.; expenditure, £115, 18s. 11d.; (9.) Nahtaur, population, 9392; municipal revenue, £147, 8s. 1d.; expenditure, £84, 3s. 7d.; (10.) Jaháld, population, 5979; not a municipal town: (11.) Chándpur, population, 12,033; municipal income, £506, 12s.; expenditure, £378, 2s.; (12.) Nagíná, population, 19,696; municipal income, £925, 12s.; expenditure, £779, 16s.; (13.) Kíratpur, population, 9579; municipal income, £117, 14s.; expenditure, £91, 12s.

Until the latter part of the 18th century Bijnaur belonged to the brave Rohilla Afghans, whose subjugation forms so deep a blot on the career of Warren Hastings. In 1774 the mercenary arms of Britain subjected this people to the oppressive rule of the Nawáb of Oudh, who in turn ceded the district to the East India Company in 1802.

BIKÁNIR, a native state of Rájputáná, under the political superintendence of the British Government, lies between 27° 30' and 29° 55' N. lat., and 72° 30' and 75° 40' E. long. It is bounded on the N. by the Panjáb, on the E. by the British districts of Hariána and Shekávati, on the S. by the native state of Jodhpur or Márwár, and on the W. by the native states of Jasalmír and Bháwalpur. Length of the state from E. to W. 200 miles; breadth, 160 miles; area, 17,676 square miles. The natural aspect of the country is one desolate tract, without a single permanently running stream. Its surface is overspread with undulating sand-hills, of from 20 to 100 feet above the average level, and so loose that men and quadrupeds stepping off the beaten track sink as if in snow. Two streams, the Káturi and Gágar attempt to flow through this diurnal region, but are lost in its sands. Water is very scarce, and is raised from wells of from 250 to 340 feet in depth. A few shallow salt lakes are filled by rain water, but they dry up on the setting in of hot weather, leaving a thick crust of salt on their beds, which is used for commercial and domestic purposes. The population of the state has been estimated at 539,000, consisting chiefly of Játa, Rájputs (to which race the chief belongs), and other Hindu tribes, inhabiting 1814 villages, which, according to Elphinstone, are composed of "a few round huts of straw, with low walls and conical roofs, like little stacks of corn." *Bajrá* and *moá* (two species of millet) and water melons are almost the only agricultural products. The inhabitants are very poor. They live chiefly by pasturage,—rearing camels, and horses of a fine breed, which fetch good prices. From the wool which their sheep yield they manufacture every article of native dress and good blankets. The other industries are leather work, sugar-refining, goldsmith's work, iron, brass, copper, stone masonry, tanning, weaving, dyeing, and carpentry. In 1870-71 the total revenue amounted to £111,546, and the expenditure to £123,196. The state is in debt, and is said to be badly managed, the present Mahárájá being entirely guided by favourites. The military force of the state amounts to 5000 regulars, horse and foot. Bikanir was invaded by the adventurer George Thomas in 1799, who levied from the Rájá a black mail of £20,000. The Rájá entered into a treaty of dependence with the British Government in 1818. Principal towns:—Bikanir, the capital, Churu, Rájgarh, Ratangarh, and Remi. The town of Bikanir is surrounded by a stone wall, 6 feet thick, 15 to 30 feet high, and 3½ miles in circuit, with five gates and three sally-ports. Estimated population, 60,000. The citadel is half a mile north-east of the city, and is surrounded by a rampart with bastions.

BILÁSPUR, a district of British India, in the Central Provinces, forms the northern section of the Chhattisgarh plateau, and is situated between 21° 45' and 23° 10' N. lat. and 81° 30' and 83° 15' E. long. It is bounded on the N. by the native states of Rewá and Korá; on the E. by the Údaipur tributary state of Chhotá Nágpur, and the district of Sambalpur; on the S. by the Ráipur district; and on the W. by the hilly tracts of Mandlá and Balágit. Extreme length of the district north and south, 106 miles; extreme breadth from east to west, 136 miles; area, 7794 square miles. Biláspur district forms the upper half of the basin of the River Mahárádi. It is almost enclosed on the north, west, and east by ranges of hills, while its southern boundary is generally open and accessible, well cultivated, and closely dotted with villages embedded in groups of fruit trees. The principal hills are—(1.) the Maikál range, situated in the north-western extremity of the district; (2.) a chain of hills forming part of the Vindhyan range, on the north; (3.) the Korbá hills, an offshoot of the Vindhya, on the eastern boundary; and (4.) the Sonákhán block of hills, in the vicinity of the Mahárádi

River. The Mahanadi is the principal river of the district, and governs the whole drainage and river system of the surrounding country. It takes its rise in a mountainous region which is described as the wildest of all wild parts of the Central Provinces, crosses the Bilaspur boundary near Seorinárin, and after a course of 25 miles in the south-eastern extremity of the district enters Sambalpur district. Within Bilaspur the river is everywhere navigable for six months in the year. Minor rivers—the Sakri, Hámp, Tesná, Agar, Maniári, Arpá, Kharod, Lilágár, Jonk, and Barad. The most important affluents of the Mahanadi are the Seonath and Hasdá. Besides the natural water supply afforded by the rivers, Bilaspur abounds in tanks,—these numbering 7018, as shown in the settlement statistics. The census of 1872 disclosed a total population of 715,398, of whom 435,379, or 60·86 per cent., are Hindus; 7024, or ·98 per cent., Mahometans; 6 Buddhists; 37 Christians; and 272,952, or 38·15 per cent., belong to aboriginal tribes, such as Gonda, Kanwara, Bhumias, Binjwara, Dhanwara, &c. Among the Hindus, the Chámars and Pankás deserve particular notice. The former, who form the shoemaker and leather-dealing caste of the Hindu community, had always been held in utter contempt by the other Hindu castes. But between 1820 and 1830 a religious movement, having for its object their freedom from the trammels of caste, was inaugurated by a member of the caste, named Ghásí Dás, who preached the unity of God and the equality of men. Ghásí Dás gave himself out as a messenger of God; he prohibited the adoration of idols, and enjoined the worship of the Supreme Being without any visible sign or representation. The followers of the new faith call themselves *Satnáms*, or the worshippers of *Satnáms* or God. They do not keep the Hindu festivals, and they defy the contempt of the Bráhmans. Ghásí Dás, the founder of the faith, was their first high priest. He died in 1850; his son succeeded him, but was assassinated (it was said by the Hindus), and the grandson is the present high priest. The Chámars in Bilaspur number 164,388, or 21 per cent. of the total population. The Pankás, who form about a sixth of the population, are all Kabirpanthis, or followers of Kabir, a religious reformer of the 15th century. There is no great difference between the Kabir Pankás and the Satnáms. They both abstain from meat and liquor, marry at the age of puberty, ordinarily celebrate their ceremonies through the agency of the elders of their own caste, and bury their dead. The Pankás worship the Supreme Being under the name of *Kabir*, and the Chámars under the name of *Satnáms*; while each community has a high priest to whom reverence is paid. At present the majority of the Pankás are cultivators, though formerly all were weavers. The Gondas are the most numerous among the aboriginal tribes, the census of 1872 returning them at 107,359, or 15 per cent. of the total district population; but so great an intermixture has taken place between them and the Hindu races that they have lost their language and most of their ethnical characteristics, such as the flat forehead, squat nose, prominent nostril, dark skin, &c., and are scarcely distinguishable from the other classes of the Hindu labouring population. In addition to some of the Hindu deities which they worship, the Gondas have their own gods—Bera Deva and Dúlá Deva. The Kanwáras are the next largest section of the aboriginal population, and number 28,419 souls. The upper class among them claim to be Rájputs, and are divided into numerous septa. Although an aboriginal tribe, the census returns them as a Hindu caste. All the northern landholders of Bilaspur belong to this tribe, which consequently occupies an influential position.

Rice, wheat, pulses, oil-seeds, and cotton are the chief agricultural staples. The census of 1872 returns the total area of the district

at 7798 square miles, of which 2089 square miles are under cultivation. The following is the approximate acreage under different crops:—Rice, 882,318 acres; wheat, 79,203; other food grains, 225,448; oil-seeds, 56,039; sugar-cane, 6888; cotton, 72,922; opium, 124; tobacco, 2317; and vegetables, 12,829; total, 1,337,483 acres, or 2089·81 square miles. Of the population, 438,880 live by agriculture, while 276,518 are non-agriculturists. The chief wealth of the district consists in its agricultural produce, and it is not inaptly termed “the land of plenty” by the *Banjáras* or traders, who find here an inexhaustible store of surplus produce for export. Scarcity of food is almost unknown. Coal and iron are the minerals of the district; the former is not worked, and the latter but very slightly, the annual out-turn being reported at about 15 tons only. Sandstone, for building purposes, is quarried near Bilaspur and Seorinárin. The forests produce timber, edible and medicinal roots and plants, lac and tasar-silk cocoons. Imports in 1867–68—sugar, £5274; metals and hardware, £10,985; English piece-goods, £11,194; cattle, £9240; miscellaneous, £10,531; total, £47,224. Exports—rice (as ascertained), £8659; wheat, £5808; other edible grains, £150; cotton, £16,407; molasses, £297; oil-seeds, £18; lac, £15,608; miscellaneous, £5609; total, £53,546. Among local industries the most important is the weaving trade. It is estimated that cotton and silk cloths to the value of £95,000 are every year manufactured. The traffic routes of the district are five in number, the three most important of which are rugged and inaccessible, unfit for wheeled carriages, admitting export or import only by means of pack-bullocks during six months of the year. The other two are simply tracks across the hills and through the jungle. The revenue divisions of the district correspond with its physical features; the hilly area, covering about 5000 square miles, is almost entirely held by large landed proprietors called *Somnádas*, who have always occupied a somewhat independent position. The open country, with an area of 3000 square miles, is known as the *Khadás* jurisdiction, or the tract under direct revenue management through Government officers. Pendra, Mátin, Uprón, Kendá, Lápha, Chhári, Korá, Chámpá, Sakri, Bhátágon, Bilágarh, Katangi, Pandariá, Kawardá, and Madanpur, are the 15 *Somnádas* comprising the hilly area, of which Sakri and Kawardá have been acknowledged as feudatories. Bilaspur, Mungelí, and Seorinárin are the three *parganas* in the *Khadás* tract. In 1868–69, the revenues of the district were as follows:—Land-tax, £27,195; excise, £892; stamps, £3234; forest, £484; assessed taxes, £1223; total, £31,977. For the protection of person and property, Government maintained in 1866–69 a regular police of 810 officers and men, at a total annual cost of £4363, besides the village watch or rural constabulary. The executive staff of the district consists of the deputy-commissioner, with two assistants and several sub-collectors. Bilaspur contained, in 1868–69, 33 Government and 58 private schools, attended by 3076 pupils. Besides Bilaspur, to be separately noticed below, there are only four towns of any importance in the district:—Ratanpur, the seat of the ancient Rájás, situated at the base of the Kendá, offshoots of the Vindhyan range, highly attractive to antiquarians and archaeologists on account of its great antiquity; it is now in a dilapidated and deserted state. Population, 6111. Mungelí, a rising market-town, situated on the banks of the River Agar. Population, 3542. Kawardá, population, 6590. Seorinárin, on the Mahanadi, a favourite residence of the Ratanpur court in former days, contains a temple of the Hindu god Naráyan, from which it derives its name. Population about 1600. The climate of the district, though relaxing, is not oppressive. Cholera occasionally breaks out in the epidemic form, being generally disseminated by the Jagannáth pilgrims from Central India, whose route to Orissa lies through the district. Fever and smallpox also prevail.

The early history of the district is very obscure. From remote ages it was governed by kings of the Haihai dynasty, known as the Chhattisgarh Rájás, on account of thirty-six forts, of which they were the lords. A genealogical list of kings of this dynasty has been carefully kept up to the fifty-fifth representative in the year 1740, when the country was seized without a struggle by the Marhattás of Nágpur. From 1818 to 1830 Bilaspur came under the management of the British Government, the Marhattá chief of Nágpur being then a minor. In 1854 the country finally lapsed to the British Government, the chief having died without issue. During the Sepoy mutiny a hill chief of the district gave some trouble, but he was speedily captured and executed.

BILASPUR, the chief town of the district of the same name, is situated on the south bank of the River Arpá. It is said to have been founded by a fisherwoman, named Bilása, three hundred years ago, and still retains her name. The place, however, came to note only about one

hundred years ago, when a Marhattá official took up his abode there, and began to build a fort which was never completed. In 1862 it was made the headquarters of the district, and is now a rising town. It lies in 22° 2' N. lat. and 82° 5' E. long. The population was estimated in 1870 at 6190, but Biláspur is not mentioned in the census of 1872 as containing upwards of 5000 inhabitants.

BILBAO, one of the principal cities of Spain, and capital of the province to which it gives its name, is situated in 43° 14' N. lat. and 2° 56' W. long., in a small but beautiful and fertile valley, bounded on three sides by mountains, about six miles from the sea, on the banks of the River Ansa, which is also known as the Nervion, or, in Basque, as the Ibaizabal. The old town lies on the left bank, while the new town, which is by far the more important, rises on the right in handsome terraces. Communication across the river is afforded by several bridges, of which the oldest, San Antonio, is of stone, and dates from the 14th century; the second was finished in 1827, the third in 1847, and the fourth, an iron structure, in 1868. The houses in the principal streets are built of hewn stone, and are several stories high, with projecting eaves that give shelter both from sun and rain. Many of the streets are very narrow, and they have an appearance of cleanliness and quiet. For a long time no carts or carriages were permitted to enter the city for fear of polluting and injuring the pavement, and the transport of goods was carried on in trucks. The principal promenades are the Paseo del Arenal, which lies along the right bank of the river, the Campo Volantin in the same neighbourhood, and the Paseo de los Cafios, so called from its forming the roof of the great aqueduct for conveying the water of the river to the town. The public buildings comprise several churches, of which the oldest, Santiago, is of earlier date than the city itself, the town-hall, the palace of the *Diputacion Provincial*, an arsenal, a hospital, a theatre, and an abattoir. Of the educational institutions the most important are the *Colegio General de Vizcaya*, a nautical academy, and the schools supported by the board of trade for gratuitous instruction in design, architecture, languages, and mathematics. A bank of issue and discount was founded in 1857. The industrial establishments include iron and steel foundries (for which the town was at one time famous), anchor-forges, potteries, glass-works, paper-mills, and a cotton factory; and leather, sail-cloth, ropes, and tobacco are also manufactured. The exports consist mainly of grain and flour, iron, zinc, and lead ore, wine, madder, liquorice, lamb and goat skins, chestnuts, and oil. The wool trade has ceased for many years, and shipbuilding has greatly declined. A great stimulus was given to the import trade by the construction of the Bilbao and Tudela railway, which was completed in 1863; but the prosperity of the place is hindered by its distance from the sea. Large sums of money have been spent in improving the river, but ships of any size have to discharge at Portugalete, the average depth on the bar being 13½ feet at high tides. In spite of this disadvantage, however, Bilbao ranks as one of the principal trading ports in Spain. In 1870 the total tonnage of the ships that entered was 160,952, and the value of the imports amounted to £2,075,900. There is regular steam communication with London and Liverpool. Population, 17,649. Bilbao, or Belvaio, was founded about 1300 by Don Pedro Lopez de Haro, and soon rose into importance. It was captured by the French in 1795, and was again held by them from 1808 to 1813. During the Carlist contest it was gallantly defended against Zumalacarreghi in 1835.

BILDERDIJK, WILLEM, a modern Dutch poet, by some considered to be the most eminent that his country has produced, was born at Amsterdam in 1756. In 1776, after completing a wide course of study at Leyden Univer-

sity, he gained the prize from the Leyden Society of Art for his poem on the *Influence of Poetry on States and Governments*. In the following year he gained another prize for his poem *Love of Fatherland*, and in 1779 he translated the *Œdipus Tyrannus* of Sophocles. In 1786 he left Holland on account of the disturbed state of public affairs, and after residing some time in Germany crossed to England, where he remained till 1806. Returning then to his native country he was received with great favour by the new king Louis Napoleon, who made him president of the recently founded Institute of Holland. He died on the 18th December 1831. His finest poetical works are the *Buitenleven*, or Rural Life, a free imitation of Delille; *De Menoch*, similarly taken from Pope; *Die Ziekte der Geleerden*, the Maladies of the Learned; *Die Oudergang der eerste Wereld*, the Destruction of the First World. Some of his dramatic and epic poems are also highly esteemed. His second wife, besides some original work, translated the *Roderick* of Southey, who was very intimate with Bilderdijk, and resided for some time with him.

BILE. See PHYIOLOGY.

BILFINGER, GEORGE BERNHARD, was born on the 23d January 1693, at Cannstadt in Württemberg. His father was a Lutheran minister. By a singularity of constitution, hereditary in his family, Bifinger came into the world with twelve fingers and as many toes. From his earliest years he showed the greatest inclination to learning. He studied in the schools of Blaubeuren and Bobenhausen, and afterwards entered the theological seminary of Tübingen. The works of Wolff, which he studied in order to learn mathematics, soon inspired him with a taste for the Wolffian philosophy and that of Leibnitz,—a passion which made him neglect for some time his other studies. Returning to theology, he wished at least to try to connect it with his favourite science of philosophy; and in this spirit he composed the treatise entitled *Disquisitiones Philosophicæ, De Deo, Anima Humana, Mundo, &c.* This work, containing nothing original, but giving an admirably clear representation of Wolff's philosophy, met with great success, and contributed to the advancement of the author, who was appointed soon after to the office of preacher at the castle of Tübingen, and of reader in the school of theology. He soon after left for Halle, in order to attend the lectures of Wolff; and, after two years of study, returned to Tübingen, where the Wolffian philosophy was not yet in favour. He found his protectors there cooled, saw his lectures deserted, and perceived himself shunned, from the dislike of his new doctrines; his ecclesiastical views also suffered from the same cause. By the intervention of Wolff he received an invitation to Petersburg, where Peter I. wished to appoint him professor of logic and metaphysics, and member of his new academy. He was received in that city, where he arrived in 1725, with the consideration due to his abilities. The Academy of Sciences of Paris having proposed about this time the famous problem on the cause of gravity, Bifinger gained the prize, which was a thousand crowns. His reputation was so much increased by this success that he was almost immediately recalled to his native country by the Duke Eberhard Ludwig of Württemberg. He quitted St Petersburg in 1731, and in 1735 the Duke Charles Alexander appointed him privy councillor. After careful preparation Bifinger entered on the duties of his new office, and soon approved himself one of the best and most enlightened ministers that his country had yet produced. Under his wise administration the commerce, public instruction, and agriculture of Württemberg flourished, and the state was raised to a position it had not before attained. Bifinger died at Stuttgart on the 18th February 1750.



**BILL** means generally a statement in writing, and is derived from the Latin *bulleta*. The word is used in a great many special applications.

**BILL, in Parliament,** is a form of statute submitted to either House, which, after passing both Houses and receiving the royal assent, becomes an Act. The modern system of legislating by means of bill and statute appears to have been introduced in the reign of Henry VI., superseding the older mode of proceeding by petitions from the Commons, assented to by the king, and afterwards enrolled by the judges. A bill consists of a preamble, reciting the necessity for legislation, and clauses which contain the enactments. The procedure with regard to bills is much the same in both Houses. Leave having been obtained, the bill is presented by the member in charge of it, and the first reading is usually allowed without opposition. At the second reading the principle of the bill is placed in issue; the usual form of amendment is that the bill be read a second time that day three or six months, the direct rejection of bills being incompatible with the courtesy of the House. The next stage is the committee, in which the different clauses are gone through in detail by the House sitting under the presidency of a chairman of committees. Two principles must be observed in reference to amendments:—(1), The amendment must not be irrelevant to the subject-matter of the clause; nor (2), must it propose to leave out all the words of the clause after the initial "That" in order that new words may be introduced. The bill having been fully considered the committee rises, the speaker resumes the chair, and the chairman of committee reports the bill to the House, which is up to this time supposed to be ignorant of the proceedings of the committee. A bill may be referred to a select committee (the course followed with private bills) or recommitted as often as the House desires. On the third reading the judgment of the House is expressed on the entire bill as it leaves the hands of the committee; and after the third reading the motion that the bill do pass is usually allowed without opposition. The bill is then communicated to the other House, where it passes through the same stages. Should the one House make amendments on a bill sent up by the other, the latter considers the amendments, and if they are not agreed to the bill is laid aside, or postponed for three or six months, or a message is sent with reasons for disagreement, or a conference between the Houses is requested. Having passed through both Houses the bill receives the royal assent, and therewith the "complement and perfection of a law." Bills are divided into public and private; the latter includes every bill for "the particular interest or benefit of any person or persons," whether individuals or corporations. They are brought in upon the solicitation of parties interested, and the payment of fees is an indispensable element of their progress. Occasionally there is some difficulty in assigning a bill to its proper class, e.g., in bills relating to the metropolis, which, on account of the magnitude of the interests involved, are sometimes treated as public bills, although having, according to the definition, a purely private character. Private bills are subject to special regulations, and in case of opposition the proceedings before the select committees assume the form of an ordinary litigation. The chairman of committees in the Lords, and the chairman of ways and means in the Commons, are required to watch unopposed bills. Certain bills can only originate in one of other of the two Houses, e.g., money bills in the House of Commons, and bills for the restitution of honours and blood in the House of Lords; and any bill concerning the privileges of either House should originate in the House to which it relates.

A **BILL OF EXCHANGE** is defined as "an unconditional written order from A to B, directing B to pay to C a sum certain

of money therein named." A is called the drawer, B the drawee, and C the payee. When the drawer has undertaken to pay the bill he is called the acceptor. Contrary to the general rule in the law of England the benefit of a contract arising on a bill of exchange is assignable, and consideration will be presumed unless the contrary appear. Bills of exchange are believed to have been in use in the 14th century, but the first recorded decision of an English court regarding them occurs in the reign of James I. The courts long regarded them with jealousy as an exception to the common law, and restricted their use to the class of merchants, but their obvious utility overcame the scruples of the judges. The law on this subject has been evolved in a long series of judicial decisions. The following are a few of its leading principles:—A bill to be transferable must contain a direction to the order of the payee or to bearer. If payable to order it must be transferred by endorsement; but if to bearer, it may be transferred by mere delivery. A *blank* endorsement (e.g., the mere signature of the endorser) makes the bill payable to bearer; a special endorsement directs payment to a person named, or his order. Every endorser of a bill is in effect a new drawer, and is liable to every succeeding holder in default of acceptance or payment. Just as the original drawer contracts to pay the payee, if the acceptor do not, so the endorser contracts that, if the drawer shall not pay the bill, he, on receiving due notice of the bill being dishonoured, will pay the holder what the drawee ought to have paid. An endorsement is held to admit "the signature and capacity of every prior party," and an endorser, in default of acceptance or payment, has a right of action against all those whose names were on the bill when it was endorsed to him. When a bill is transferred by delivery without endorsement it is generally regarded as sold, and the instrument is taken with all its risks. There are, however, some exceptions to this rule, as in the case of payment by bill for a precedent debt, &c., and the transferor will be held responsible if he knows at the time of sale that the bills are good for nothing. When a bill is payable to bearer it circulates like money, and the *bona fide* possessor is considered the true owner. Bills should be presented as soon as possible to the drawer or his agent for acceptance, which must be in writing on the bill. They should be presented for payment at the proper time, and the laws of commercial countries usually allow three *days of grace* after the day on which the bill becomes due. If the bill is not duly presented by the holder, the antecedent parties are relieved from liability. If the bill is not accepted, or after acceptance not paid, the holder must give *notice of dishonour* to the antecedent parties within a reasonable time, otherwise their liability will be discharged. When a foreign bill is dishonoured the custom of merchants requires that it should be *protested*. The protest is a solemn declaration by a notary written under a copy of the bill that payment or acceptance has been demanded and refused. Bills and notes, by the usage of trade, carry interest from the date of maturity. If in an action on a bill it turn out that the bill has been lost, the action may still be maintained provided that an indemnity is given against the claims of any other persons upon the instrument. The Act 18 and 19 Vict. c. 67, gives a summary process to the plaintiff in an action on a bill of exchange or promissory note commenced within six months after the same has become due or payable. Unless the defendant has obtained leave to appear and has appeared to the action, the plaintiff may sign final judgment for the amount with costs. The defendant, if he wishes to defend the action, must pay the money into court or show by affidavit such facts as may be sufficient to induce the judge to give him leave.

Foreign Bills (as distinguished from Inland Bills) are

bills drawn or payable abroad. By 19 and 20 Vict. c. 97, § 7, bills or notes drawn on one part and payable in any other part of the British Isles are inland bills. Foreign bills are usually drawn in sets or parts, each containing a condition to be payable only so long as the others continue unpaid.

When a bill is accepted by the drawee without consideration, and merely in order that the drawer may be able to raise money upon it, it is called an *accommodation* bill. Both parties are liable to the holder; but, as between themselves, the drawer is the principal and the acceptor a sort of surety. When acceptance has been refused and the bill protested, a stranger may accept it "*supra protest*, in honour of the drawer or endorser." The effect of this is to render the acceptor liable if the drawer does not pay, and the party for whose honour it was made, and parties antecedent to him, become liable to the acceptor. Payment for the honour of one of the parties may likewise be made by a mere stranger when a bill has been protested for non-payment, who thereupon acquires a claim against such person and all those to whom he could have resorted.

The negotiability of promissory notes and bank cheques is for the most part regulated by the same principles as bills of exchange. A promissory note is a "promise in writing to pay a specified sum at a time therein limited, to a person therein named or his order or to bearer." Cheques which are inland bills of exchange drawn on a banker have become subject to certain peculiar usages. See EXCHANGE.

A BILL OF LADING is a document signed by the master of a general ship and delivered to the owners of goods conveyed therein. It is usually made out in several parts or copies, of which the shipper retains one and sends one or more to the consignee, while the master keeps one for his own guidance. The following is the usual form:—Shipped in good order and well conditioned by [A. B., merchant] in and upon the good ship called [The Good Intent], whereof [C. D.] is master for this present voyage, and now riding at anchor in the [Port of Southampton], and bound to [Cádiz in Spain, twenty cases of hardware and fifty bales of cotton goods]; being marked and numbered as in the margin, and are to be delivered in the like good order and well conditioned at the aforesaid port [of Cádiz], the act of God, the Queen's enemies, fire, and all and every other dangers and accidents of the seas, rivers, and navigations of whatever kind or nature whatsoever excepted, unto [E. F., merchant], or to his assigns, he or they paying freight for the said goods [ ] per case, and [ ] per bale freight, with primage and average accustomed. In witness whereof, &c.

Every bill of lading requires a sixpenny stamp. By the mercantile law a bill of lading is a negotiable instrument, and the property in the goods may be transferred by endorsement. By 18 and 19 Vict. c. 111, every consignor of goods named on a bill of lading, and every endorser to whom the property of the goods mentioned therein passes by reason of the consignment or endorsement, shall have transferred to and invested in him all rights of suit, and be subject to the same liabilities in respect of the goods as if the contract contained in the bill of lading had been made with himself.

A BILL OF SALE is an assignment of personal property. It is frequently made by way of security, the property remaining in possession of the vendor. For the protection of creditors from secret or fraudulent sale, the Bills of Sale Act, 1854, and the Amendment Act, 29 and 30 Vict. c. 96, were passed. By these Acts a bill of sale of personal chattels made at any time by a defendant in an action will be void as against a plaintiff on whose behalf a writ of execution in such action shall be sued out and delivered, so far as

regards any personal chattels in defendant's possession at or after the time of executing such writ, unless such bill of sale shall be duly registered for public inspection in the Court of Queen's Bench within twenty-one days of its date. The registration must be renewed once in every five years during the subsistence of the security.

BILL IN CHANCERY. A suit in the Court of Chancery was generally commenced by a bill, addressed to the lord chancellor, containing a statement of the plaintiff's case, and praying for relief. By the Chancery Amendment Act, 1862, it is enacted that "every bill shall contain as concisely as may be, a narrative of the material facts, matters, and circumstances on which the plaintiff relies: such narrative being divided into paragraphs numbered consecutively, and each paragraph containing as nearly as may be a separate or distinct statement or allegation; and shall pray specifically for the relief which the plaintiff may conceive himself entitled to, and also for general relief." By the Judicature Act, 1873, a new form of procedure is established for all the superior courts. See ACTION. (22)

BILLETING. The law as to billeting soldiers is regulated by the provisions of the Annual Mutiny Act (38 Vict. c. 7, §§ 63-67). Constables of parishes and places, police officers, high constables, and other chief officers and magistrates may billet officers and soldiers on actual service, with their horses and baggage, in victualling house, inn, hotel, livery stable, ale-house, or the house of any seller of wine by retail to be drunk in such house, or the houses of persons selling brandy, spirits, strong waters, cider, or metheglin by retail; but no officer or soldier shall be billeted in any private houses, or in any canteen under the authority of the War Department, nor on persons keeping taverns only being vintners of the city of London, nor on distillers, nor on shopkeepers whose principal dealing is more in other goods than in brandy and strong waters, so as such distillers and shopkeepers do not permit tipping in such houses. If the victualler has not sufficient accommodation in his own house he must find it in the immediate neighbourhood. The following sums are allowed as compensation:—For hot meal, to be supplied each day to soldiers on the march, 10d., with 2½d. for a bed; for other soldiers, entitled to bed, candles, use of fire and cooking utensils, 4d. per diem for each soldier; for ten pounds of oats, twelve of hay, and eight of straw, 1s. 9d. per diem. Military officers must not act as justices in billeting.

BILLIARDS is a well-known indoor game of skill, played on a rectangular table with ivory balls, which are driven into pockets and against each other according to certain defined rules. Of the origin of billiards comparatively little is known,—some considering that the game was invented by the French, and others that it was improved by them out of an ancient German diversion. Even the French themselves are doubtful on this point; for, while it is generally asserted that Henrique Devigne, an artist, who lived in the reign of Charles IX., gave form and rule to the pastime, the *Dictionnaire Universel* and the *Académie des Jeux* ascribe its invention to the English. Bouillet in the first work says—"Billiards appear to be derived from the game of bowls. It was anciently known in England, where, perhaps, it was invented. It was brought into France by Louis XIV., whose physician recommended this exercise." In the other work quoted we read—"It would seem that the game was invented in England." Strutt, a rather doubtful authority, notwithstanding the reputation attained by his *Sports and Pastimes of the People of England*, considers it probable that it was the ancient game of Paille-maille on a table instead of on the ground or floor,—an improvement, he says, "which answered two good purposes: it precluded the necessity of

the player to kneel or stoop exceedingly when he struck the bowl, and accommodated the game to the limits of a chamber." Whatever its origin, and whatever the manner in which it was originally played, it is certain that it was common in the time of Shakespeare, who makes Cleopatra, in the absence of Antony, invite her attendant to join in the pastime—

"Let us to billiards :  
Come, Charmin."—*Ant. and Cleo. Act. ii. sc. 5.*

Billiards was originally played, it seems, in a method even now adopted in the rustic game of Rural Billiards, by driving a ball through a ring which revolved on a pin or stick fixed to the table or floor. In Cotton's *Complete Gamester*, published in 1674, we are told that this "most gentle, cleanly, and ingenious game" was first played in Italy, though in another page he mentions Spain as its birthplace. At that date billiards must have been well enough known, for we are told that "for the excellency of the recreation, it is much approved of and played by most nations of Europe, especially in England, there being few towns of note therein which hath not a public billiard table, neither are they wanting in many noble and private families in the country." Since Cotton every compiler of books on games has had more or less to say about billiards; though, curiously enough, Hoyle, who is often quoted as an authority, makes no mention whatever of the game. It is only in the later editions and continuations of Hoyle that billiards, bagatelle, cricket, &c., find place. It is not, indeed, till our own day that anything like a scientific treatise on billiards has appeared, or that the game itself has been lifted out of the tavern—whence, in spite of its historians' praises, it gradually descended—to its present more favoured position as a harmless and amusing indoor game.

**The Table.**—The shape of the table has varied from time to time, probably to suit the dimensions of the room in which it was placed. At first it was square, with a hole or pocket at each corner to receive the balls driven forward with a cue or mace; then it was lengthened and provided with two other pockets; and occasionally it has been made round, oval, triangular, or octagonal, with or without pockets according to the game required. The cannon game in France is played on a pocketless table 8 feet by 4; the same game of the United States is played on a table 10 feet by 6, commonly made without pockets; but in England the regular table of the clubs and public rooms is a massive structure of timber, with a bed or surface of slate or metal 12 feet long by 6 feet wide, or two equal squares of 5 feet 10½ inches across within the cushions. It is covered by a fine green cloth, and surrounded by elastic india-rubber cushions, at the junctions of which are netted pockets—one at each corner, and one midway at each of the longer sides. The table must be perfectly level and sufficiently firm to prevent vibration; and its usual height from the floor to the surface is 3 feet. The space required between table and wall is at least four feet. Smaller tables for use in private houses have lately been introduced. Whether large or small, each table is provided with a baulk line and semicircle and several marks or spots to regulate the mode of play. The baulk line is drawn straight across the table 28 inches from the bottom or lower cushion, and from it is struck a semicircle of from 21 to 23 inches in diameter. In the middle of the baulk line is the baulk spot, and in the middle of the table the centre spot. Thirteen inches from the top cushion is the red-ball spot, and half-way between the centre and the top cushion is the pyramid spot,—all these spots being on a line which, if drawn from end to end, would divide the table into two oblong halves.

**Games.**—The principal games are three in number,—

billiards proper, pyramids, and pool; and from these spring a variety of others. The object of the player in each game, however, is to drive one or other of the balls into one or other of the pockets, or to cause the striker's ball to come into successive contact with two other balls. The one stroke is known as a hazard, the other as a cannon; and from hazards and cannons, together with misses, forfeitures, and foul strokes, are reckoned the points of the game. When the ball is forced into a pocket the stroke is called a winning hazard; when the striker's ball falls into a pocket after contact with the object ball, the stroke is a losing hazard; and these hazards count two or three to the player's score according as they are made from the white or the red ball—two points for the white, three for the red. Two points are scored for the cannon, three for a coup—a term used when the player's ball runs into a pocket without striking a ball; and one point for a miss, whether given purposely or accidentally. These strokes are all made with a cue, which is a long stick of ash, or other hard wood, gradually tapering to the end, which is tipped with leather and rubbed with chalk to prevent it slipping off the surface of the ball struck. The mace or hammer-headed cue, once common, is no longer used, even by ladies. The cue is taken in the right hand, generally between the fingers and thumb, and not grasped in the palm; and with the left hand the player makes a bridge, by resting the wrist and the tips of the fingers on the table, arching the latter, and extending the thumb in such a way as to allow a passage in which the cue may slide. The player then proceeds with his game, according to the following rules:—

*Billiards proper, or the English game, consists of winning and losing hazards, cannons, and forfeitures. It is usually played 50 or 100 points, reckoned as already explained, three for each red hazard, two for each white hazard, and two for each cannon. Public matches between adepts are played 100, 500, or 1000 up, but the rules which govern them are the same. The remarks within brackets are explanatory.*—1. The game of billiards proper commences by stringing for the lead and choice of balls. [The players standing behind the baulk line, strike each a ball from the semicircle up to the top cushion, and he whose ball on its return stops nearest the bottom cushion has the choice of lead and balls.] 2. The red ball is placed on the spot at the commencement of the game, and replaced when it is pocketed or forced over the table. ["Breaking the balls" is the replacing them as at the beginning of a game. The balls are said to be "broken" when the first player has struck the red or given a miss; and the player's ball when off the table is said to be "in hand."] 3. The player who makes one stroke in a game must finish that game or consent to lose it. [Intended to meet cases of dispute.] 4. In the case of foul strokes, the adversary has the option of either allowing the striker to proceed, of having the ball replaced, or of breaking the balls. No score can be reckoned for a foul stroke. [The following are foul strokes:—If the player move a ball in the act of striking; if he play with the wrong ball; if he touch a ball twice in making a stroke; if he play at a ball while it is running; if he touch a ball with his hand, cue, or person, otherwise than is necessary for the stroke; if he in any way touch his opponent's ball.] 5. If the adversary neglect to observe or to claim a foul stroke, the player proceeds with his game, and all the points he makes are marked. 6. If a ball spring from the table and hit a bystander, so as to prevent it falling to the floor, it is considered off the table. [The penalty in such a case is that the other player goes on, or if the ball has not struck another ball before flying off the table, the loss of three points, as for a coup.] 7. Balls lying within the baulk line cannot be played at with a ball in hand, except the player whose ball is in hand first play at a cushion beyond or outside the baulk line. 8. A line-ball cannot be played at by the striker whose ball is in hand, other than by playing his ball out of baulk against a cushion. [A line-ball is when the centre of the ball's surface lies exactly on the line across the table. The marker or umpire must decide as to whether such ball is within or without the line.] 9. A ball in hand striking a ball in baulk without having been first played out of baulk, must be replaced and played over again. 10. All misses must be given with the point of the cue. [This rule is sometimes neglected, and the player allowed to give his miss with the butt end of his cue.] 11. Should the spot be occupied so that the red ball cannot be placed on it after being pocketed, it must be placed on the centre spot, or, if that also be occupied, on the pyramid spot. [In some clubs the custom is to place the red ball on the centre spot, or on the baulk line spot, &c.]

ording to agreement.] 12. No points are reckoned for a ball or balls forced off the table after contact with the object-ball, and the adversary goes on without breaking the balls. 13. If the balls be changed in the course of play, no cannon or hazard made with such changed ball can be scored; the balls must be broken, and all points made with the wrong ball deducted from the striker's score. [In such case, however, the adversary has the privilege of playing with the changed ball, of re-changing the balls and playing on from their respective positions, or of having the balls broken.] 14. The player whose ball is in hand cannot score, unless he play his ball out of bank before striking the object-ball. [In such case the stroke must be re-made.] 15. If in drawing back his cue from a ball on the brink of a pocket the striker hole his ball, he loses three points, as for a coup. 16. A ball accidentally moved by the marker or a looker-on must be replaced. 17. A ball wilfully removed or obstructed in its course causes the loss of the offender's game. 18. If the striker's ball lie touching his opponent's ball, or the red ball, no score on that side can follow. [After the stroke the next player proceeds with his game, either by breaking the balls, or playing from the spot where his ball stopped. When balls touch, the player may either run into a pocket, or play on to a third ball; then the red is spotted and the adversary plays on from bank; or if the first player fail to do either, the balls remain as they fall, and the other goes on.]

These, with the exception of some remarks about the conduct of strangers, the payment of wagers, and so on, are the rules by which the English game of billiards is universally governed. The principal modifications of this game are the four-handed game, which is ordinary billiards by four players in sides of two, each player being allowed to instruct his partner; à la royale, or the game of three; the white winning game, consisting entirely of winning hazards; the white losing game; the red winning game; the red losing game; the cannon game; and the American game. This last is played with four balls, two white and two coloured, and consists entirely of winning hazards and cannons. There is also a Russian game, called carline or caroline, not unlike American billiards; a German game, *Wurst-partie*, in which a certain number of balls are placed in a row across the table; the Spanish, or skittle game, which the Germans call *Kugel-partie*; and French billiards or the cannon game formerly universal on the Continent, and now very popular in the United States, where the best players are Frenchmen or men of French extraction. Of these games, however, it is unnecessary to speak, as they are all much inferior to billiards, and can be easily played by any one familiar with the established English game. The lesser varieties of billiards—choice of balls, in which each player selects the ball he plays with; bricole, in which the player strikes his ball against a cushion and endeavours to reach his opponent's ball from the rebound; bar-hole, so called from a pocket or pockets being barred or stopped for one of the players; one pocket to five; winning against losing; the nomination game, which is ordinary billiards, in which the player is obliged to name his stroke before attempting it, and failing to make it gains nothing, or gives unnamed cannons and hazards to his opponent; the commanding game; the go-back game, which is played by an adept against a tyro, the latter scoring all he makes and the former going back to nothing every time his adversary makes a winning or losing hazard;—all these are so barren of interest and so seldom played as barely to deserve mention.

As to the science of the game, there is really little to be taught in books; practice and instruction from an adept will better enlighten a tyro as to the mysteries of the side-stroke, the drag, the screw, the following ball, the spot-stroke, &c., than any amount of verbal explanation. It may, however, be as well to refer briefly to these several points, in order to render this notice as complete as the space at command will admit.

The *side-stroke* is made by striking the object-ball on the side with the point of the cue. The effect of such a mode of striking the ball is to make it travel to the right or to the left, according as it is struck with a winding or slightly circular motion; and its pur-

pose is to cause the ball to proceed in a direction more or less sailing than is usual, or ordinary, when the ball is struck in or about the centre of its circumference. Many hazards and cannons, quite impossible to be made with the central stroke, are accomplished with ease and certainty by the side-stroke. In the hands of a dexterous player this stroke is both elegant and effective. The *screw*, or *twist*, is made by striking the ball low down, with a sharp, sudden blow. According as the ball is struck nearer and nearer to the cushion, it stops dead at the point of concussion with the object-ball, or recoils by a series of reverse revolutions, in the manner familiar to the schoolboy in throwing forward a hoop, and causing it to return to his hand by the twist given to its first impetus. The *following-ball* is made by striking the ball high, with a slow or following motion of the cue. Just as the low-strokes impede the motion of the ball, the follow expedites it. In the *drag* the ball is struck low without the sudden jerk of the screw, and with less than the onward push of the follow. The *spot-stroke* is a winning hazard made by pocketing the red ball in one of the corners from the spot. The great art is, first, to make sure of the hazard, and next, to leave the striking ball in such a position as to enable the player to make a similar stroke in one or other of the corner pockets. To such perfection has the spot-stroke been brought, that the winning hazard has been repeated more than two hundred and fifty times consecutively. W. Cook, the finest of English players, on November 29, 1873, in a game with the ex-champion, Joseph Bennett, made a break of 986, the longest on record. In this great performance Cook made, in all, no fewer than 292 spot-hazards, 260 of which were made consecutively. John Roberts, jun., of Manchester, has also made an extraordinary break, 800, the majority by the spot-stroke. Without the spot-hazard, the longest break hitherto made is probably less than 200.

The perfection of billiards is to be found in the nice combination of the various strokes, in such fashion as to leave the balls in a favourable position after each individual hazard and cannon; and this perfection can only be attained by the most constant and unremitting practice.

*Pyramids* is played by two or four persons—in the latter case in sides, two and two. It is played with fifteen balls, placed close together in the form of a triangle or pyramid, with the apex towards the player, and a white striking ball. The centre of the apex ball covers the second or pyramid spot, and the balls forming the pyramid should lie in a compact mass, the base in a straight line with the cushion.

*Pyramids* is a game entirely of winning hazards, and he who succeeds in pocketing the greatest number of balls wins. Usually the pyramid is made of fifteen red or coloured balls, with the striking ball white. This white ball is common to both players. Having decided on the lead, the first player, placing his ball in the half-semicircle, strikes it up to the pyramid, with a view either to lodge a ball in a pocket or to get the white safely back into bank. Should he fail to pocket a red ball, the other player goes on and strikes the white ball from the place at which it stopped. When either succeeds in making a winning hazard, he plays at any other ball he chooses, and continues his break till he ceases to score; and so the game is continued by alternate breaks until the last red ball is pocketed. The game is commonly played for a stake upon the whole, and a proportionate sum upon each ball or life,—as, for instance, 2s. game and 1s. balls. The player wins a life by pocketing a red ball or forcing it over the table; and loses a life by running his own, the white, ball into a pocket, missing the red ball, or intentionally giving a miss. In this game the bank is no protection; that is to say, the player can pocket any ball wherever it lies, either within or without the bank line, and whether the white be in hand or not. This liberty is a great and certain advantage under many circumstances, especially in the hands of a good player. It is not a very uncommon occurrence for an adept to pocket six or eight balls in a single break. Both Cook and Roberts have been known, indeed, to pocket the whole fifteen. If four persons play at pyramids, the rotation is decided by chance, and each plays alternately,—partners, as in billiards, being allowed to advise each other, each going on and continuing to play as long as he can, and ceasing when he misses a hazard. Foul strokes are reckoned as in billiards, except as regards balls touching each other. If two balls touch, the player proceeds with his game and scores a point for every winning hazard. When all the red balls but one are pocketed, he who made the last hazard plays with the white and his opponent with the red; and so on alternately, till the game terminates by the holing of one or other ball. The pyramid balls are usually a fifth smaller than the billiard balls; the former are about 3 inches in diameter, the latter 2½ inches to 3 inches.

*Loosing Pyramids*, seldom played, is the reverse of the last-named game, and consists of losing hazards, each player using the same striking ball, and taking a ball from the pyramid for every losing

hazard. As in the other game, the bank is no protection. Another variety of pyramids is known as *Shall-out*, a game at which any number of persons may play. The pyramid is formed as before, and the company play in rotation. For each winning hazard the striker receives from each player a small stake, and for each losing hazard he pays a like sum, till the game is concluded by pocketing the white or the last coloured ball.

*Pool*, a game which may be played by two or more persons, consists entirely of winning hazards. Each player subscribes a certain stake to form the pool, and at starting has three chances or lives. He is then provided with a coloured or numbered ball, and the game commences thus:—The white ball is placed on the spot and the red is played at it from the bank semicircle. If the player pocket the white he receives the price of a life from the owner of the white; but if he fail, the next player, the yellow, plays on the red; and so on alternately till all have played, or till a ball be pocketed. When a ball is pocketed the striker plays on the ball nearest his own, and goes on playing as long as he can score.

The order of play is usually as follows:—The white ball is spotted; red plays upon white; yellow upon red; then blue, brown, green, black, and spot-whites follow in the order of succession named, white playing on spot-white. The order is similar for a larger number, but it is not common for more than seven or eight to join in a pool. The player wins a life for every ball pocketed, and receives the sum agreed on for each life from the owner of that ball. He loses a life to the owner of the ball he plays on and misses; or by making a losing hazard after striking such ball; by playing at the wrong ball; by running a coup; or by forcing his ball over the table. Rules governing the game provide for many other incidents. A ball in bank may be played at by the striker whose ball is in his hand. If the striker's ball be angled—that is, so placed in the jaws of the pocket as not to allow him to strike the previously-played ball—he may have all the balls except his own and the object ball removed from the table to allow him to try bricole from the cushion. In some clubs and public rooms an angled ball is allowed to be moved an inch or two from the corner; but with a ball so removed the player must not take a life. When the striker loses a life, the next in rotation plays at the ball nearest his own; but if the player's ball happen to be in hand, he plays at the ball nearest to the centre spot on the bank line, whether it be in or out of bank. In such a case the striker can play from any part of the semicircle. Any ball lying in the way of the striker's ball, and preventing him from taking fair aim and reaching the object-ball, must be removed, and replaced after the stroke. If there be any doubt as to the nearest ball, the distance must be measured by the marker or umpire; and if the distance be equal, the ball to be played upon must be decided by chance. If the striker first pocket the ball he plays on and then runs his own into a pocket, he loses a life to the player whose ball he pocketed, which ball is then to be considered in hand. The first player who loses all his three lives can "star"; that is, by paying into the pool a sum equal to his original stake, he is entitled to as many lives as the lowest number on the marking board. Thus if the lowest number be two, he stars two; if one, he stars one. Only one star is allowed in a pool; and when there are only two players left in, no star can be purchased. The price of each life must be paid by the player losing it, immediately after the stroke is made; and the stake or pool is finally won by the player who remains longest in the game. In the event, however, of the two players last left in the pool having an equal number of lives, they may either play for the whole or divide the stake. The latter, the usual course, is followed except when the combatants agree to play out the game. When three players are left, each with one life, and the striker makes a miss, the two remaining divide the pool without a stroke—this rule being intended to meet the possible case of two players combining to take advantage of a third. When the striker has to play, he may ask which ball he has to play at, and if being wrongly informed, he play at the wrong ball, he does not lose a life. In clubs and public rooms it is usual for the marker to call the order and rotation of play: "Red upon white, and yellow's your player;" and when a ball has been pocketed, the fact is notified—"Brown upon blue, and green's your player, in hand;" and so on till there are only two or three players left in the pool.

There are some varieties of the game which need brief mention. *Singles Pool* is the white winning hazard game, played for a stake and so much for each of three or more lives. Each person has a ball, usually white and spot-white. The white is spotted, and the other plays on it from the bank semicircle; and then each plays alternately, spotting his ball after making a hazard. For each winning hazard the striker receives a life; for each losing hazard he pays a life; and the taker of the three lives wins the game. No star is allowed in single pool. The rules regulating pool are observed.

*Nearest Ball Pool* is played by any number of persons with the ordinary coloured balls, and in the same order of succession. All the rules of pool are followed, except that the bank is a protection. The white is spotted, and the red plays on it; after that each striker plays upon the ball nearest the upper or outer side of the bank line; but if all the balls lie within the bank line, and the striker's ball be in hand, he must play up to the top cushion, or place his ball on the spot. If his ball be not in hand, he plays at the nearest ball, wherever it may lie.

*Black or Everlasting Pool* is played by any number of persons in the ordinary way, except that the game is for lives only, without a subscribed stake. After the coloured balls are distributed a black ball is placed on the centre spot. At this the first striker plays. Any player, having pocketed a coloured ball, may play at the black; and if he succeed in holing it, he receives not only the life he took from the coloured ball, but the value of a life from each player. On the contrary, if he make a losing hazard off the black ball, miss it, or force his own ball off the table, he pays a life to each player. No ball can be removed to allow the striker to play on the black, but the latter may be removed to allow the striker to play at the proper object-ball. Any person may join the pool at any time, but cannot play in that round; and he may, on giving notice of his intention, retire at the end of a clear round, until which time his ball remains on the table, and stands its chance with the rest. The price per life is determined, as in the other pool games, previously to commencing; and it is usual for the marker or leader of the game to notify the conclusion of each clear round.

*Skittle Pool* is played by any number of persons with three balls, a red and two white, and twelve skittles—ten of which are white, and two black. The skittles and balls are arranged, according to a set design, on the table, and the game is played for small stakes determined by the number of skittles knocked over, after striking at a ball. It is an amusing, but unscientific game, encumbered with rules which cannot be understood without a diagram.

*Penny Pot* is the last of the pool games needing notice. It is played as ordinary pool, with the same order of rotation, by any number of players. Instead, however, of subscribing for a pool, and confining each player to three lives, there is no subscribed stake, and the players play on as long as they like, a penny being paid by the owner to the taker of each life; winning hazards receiving, and losing hazards, misses, and coups paying; each player proceeding in turn as in regular pool.

Much might be written on the scientific principles of the ejection, the angles of incidence and reflection, &c.; but the theories advanced on these topics would lead us farther into the region of mathematics than is necessary for a description of the several games played on the billiard table. The scientific features of billiards are discussed at more or less length in several of the following works:—*Fractional Treatise on the Game of Billiards*, by E. Whita, 1807 (this was partly a translation of a French treatise, published in 1805, and partly a compilation from the article in the *Académie Universelle des Jeux*, issued in the same year, and since frequently re-edited and reprinted); *Le Musée des Jeux*, Paris, 1820; *The Noble Game of Billiards*, by Monsieur Minguand, Paris, 1834; a translation of the same, by John Thurston, London, 1835; *Kentfield on Billiards*, London, 1839, founded principally on the foregoing works; *Billiards, Game 500 up*, by Edward Russell Mardon, London, 1849; *Turner on Billiards*, a series of diagrams with instructions, Nottingham, 1849; *The Billiard Book*, by Captain Crawley, London, 1866-78; *Roberts on Billiards*, 1868; *Practical Billiards*, by Fred. Hardy, edited by W. Dufton, 1867; *Billiards*, by Joseph Bennett, ex-champion, 1873. There are besides numerous handbooks of more or less value. (G. F. P.)

**BILLITON**, or **BURROU**, an island of the East Indies, belonging to the Dutch, situated between Sumatra and Borneo, in lat. 3° S. and long. 108° E. It is of a circular form, about 50 miles in length by 45 in breadth; and has an area, according to Melvill van Carnbée, of 2500 square miles. The weather is subject to rapid changes; but the usual temperature varies from 80° to 87° Fahr. The nights are very cool. The surface in the north is hilly.—Tadjem, the highest peak, being 3230 feet in height. The sea-coast is inaccessible and surrounded with rocks, and the best harbour is still that at the chief town of Tandjong Padan. The navigation between the island and Borneo is very dangerous. Horses, buffaloes, cattle, sheep and goats, ducks, geese, fowls, and pigeons are the domestic animals of Billiton; and among its wild animals are deer, goats, jackals, monkeys, civet-cats, tiger-cats, and porcupines. The seas furnish a superabundance of fish. On the rocks along the coast are found tortoises, trepang, and edible birds'-nests, which are articles of export. The forests supply wood of

different kinds for shipbuilding, in which the inhabitants are very expert. There are important mines both of iron and tin, the former being used in the island and the latter exported to the Netherlands. The quantity of tin obtained in 1871 was 49,850 picols, or 60,532 cwts. The chief imports are rice, cotton goods, pottery, and cocoa-nuts. The population in 1871 amounted to 19,837, of whom only 59 were Europeans. The natives are of middle height and strongly built, and have expressive features. The island was formerly under the sultan of Palembang, by whom it was ceded to the English in 1812. As no mention was made of it in the treaty between the English and Dutch in 1814, the former at first refused to renounce their possession, and only recognized the Dutch claim in 1824. Till 1852 it was dependent on Banka, but at that date was raised to a sub-residency.

See *Tijdschrift v. Nederl. Indië*, vols. xii. and xv.; *Court's Relations of Brit. Gov. with the State of Palembang*, 1821; Crookewit, *Banka, Malakka, en Billiton*, 1852; Veth, *Woordenboek van Nederl. Indië*, 1869.

**BILMA**, or **KAWAR**, a town in the heart of the African desert, and the capital of the wandering tribe called the Tibboos. The place is mean and poor, surrounded with a mud wall. In its vicinity are a number of lakes, the waters of which, on evaporation by the heat of the sun, yield a quantity of very pure and fine salt, which is the object of an extensive and important trade with the countries in Central Africa. The largest of these lakes is at Agram, situated about four miles to the westward. Near Bilma is a small circular spot, kept green by a fine spring, but immediately to the south begins the most dreary part of the African desert, over which the caravans travel for fifteen days without discovering the slightest trace of vegetable life. During Nachtigal's visit in 1870 the temperature during the day rarely sank below 113° Fahr.

**BILSA**, a town of Hindustán, in the territory of Gwálior or the possessions of Sindhiá, situated on the Betwá River in lat. 23° 30' N. and long. 77° 50' E. It is enclosed with a stone wall, and defended by square towers and a ditch. The suburbs without the walls are not very extensive, but the streets are spacious, and contain some good houses. The town and the surrounding country are celebrated all over India for the excellent quality of the tobacco, which is bought up with great eagerness and exported. Population about 3000. Distance south from Gwálior, 190 miles.

**BILSTON**, formerly **BILBERTON**, a market-town of England, in the county of Stafford, 2½ miles S.E. of Wolverhampton, indebted for its importance to the iron trade, which it carries on in various departments. In the vicinity are very productive mines of coal and ironstone, as well as sand of the finest quality for casting, and grinding-stones for cutlers. Bilston contains numerous furnaces, forges, rolling and slitting mills for the preparation of iron, and a great variety of factories for japanned and painted goods, brass-work, bells, and similar articles. The town itself is very irregularly built; but it has some handsome buildings, as St Leonard's and St Mary's chapels, and the Roman Catholic chapel. The population of township, which is under an improvements commission, and forms part of the parliamentary borough of Wolverhampton, was, in 1871, 24,188.

**BINGEN**, the ancient *Bingium*, a town of the grand-duchy of Hesse-Darmstadt, in the province of Rhenish Hesse, 15 miles W. of Mentz. It is situated almost opposite Rüdesheim, on the left bank of the Rhine, at the confluence of the Nahe (or *Nava*), which is crossed near its mouth by an iron railway bridge resting on old Roman foundations. A considerable trade is carried on in wine, grain, and cattle; and tobacco, starch, and leather are manufactured. A short way down the Rhine is the

Bingerloch, a famous whirlpool, the dangers of which were almost removed by blastings undertaken by the Prussian Government in 1834; while about half-way between it and the town rises on a rock, in the middle of the stream, the tower of Bishop Hatto. On a height immediately to the south-east is the ruined castle of Klopp, originally founded by Drusus, and higher still on the Rothenberg the celebrated chapel of St Roch. Population in 1871, 5938.

**BINGHAM**, **JOSIAH**, a learned scholar and divine, was born at Wakefield in Yorkshire, in September 1668. He was educated at University College, Oxford, of which he was made fellow in 1689, and college-tutor in 1691. A sermon preached by him from the university pulpit, St Mary's, on the meaning of the word "Person" in the Fathers, brought upon him a most unjust accusation of heresy. He was compelled to give up his fellowship and leave the university; but he was immediately presented by Dr John Radcliffe to the rectory of Headbournworthy, near Winchester. In this country retirement he began his laborious and valuable work entitled *Origines Ecclesiasticæ*, or Antiquities of the Christian Church, the first volume of which appeared in 1708 and the tenth in 1722. Notwithstanding his learning and merit, Bingham received no higher preferment than that of Headbournworthy till the year 1712, when he was collated to the rectory of Havant, near Portsmouth, by Sir Jonathan Trelawney, bishop of Winchester. Nearly all his little property was lost in the great South Sea bubble of 1720. He died August 17, 1723.

**BINGLEY**, a thriving market-town in the West Riding of Yorkshire, on the River Aire, 5½ miles from Bradford, on the Midland Railway. The inhabitants are principally engaged in manufactures of worsted, cotton, paper, and iron. The town is well built, and has a neat church, a grammar school, and several charities. The population of the Local Board District, which includes a part of Mickelthwaite, was 9062 in 1871.

**BINNEY**, **THOMAS**, an English Nonconformist divine, was born at Newcastle-on-Tyne in 1798, and died February 24, 1874. After spending seven years in the employment of a bookseller he entered the theological college of Wymondley, Herts, with the view of studying for the ministry. His first pastoral charge was that of the Congregational church at Newport, Isle of Wight, to which he was inducted in 1824. Five years later—in 1829—he accepted a call to the historic Weigh House chapel, London. Here he at once established what proved to be a lasting popularity, and it was found necessary to build a much larger place of worship on Fish Street Hill, to which the congregation removed in 1834. An address delivered on the occasion of the laying of the foundation stone of the new building was afterwards published, with an appendix containing a strongly worded opinion as to the baneful influence of the Church of England, which naturally gave rise to much angry comment and a prolonged and bitter controversy. Throughout his whole career Binney was a vigorous and intelligent opponent of the state church principle, but those who inferred from one, perhaps unguarded, statement that he was a narrow-minded political dissenter did him injustice. His liberality of view and breadth of ecclesiastical sympathy entitle him to rank on questions of Nonconformity among the most distinguished of the school of Richard Baxter. Accordingly, in his later years he was not only recognized by general consent as the foremost name among all sections of English Nonconformists, but maintained friendly relations with many of the leading dignitaries of the Established Church. He continued in the active discharge of the duties of the ministry, though latterly with the help of a colleague, until 1871, when he resigned. In 1845 he paid a visit to Canada and the United States, and in 1857 he set out on a tour to the Australian

colonies, which extended over a period of two years. Though he not infrequently fell markedly below his own standard of excellence, Binney exercised an influence as a preacher, especially with young men, such as few have wielded for so long a period. A manly, vigorous intellect, fearless independence of judgment, a lively imagination, showing itself chiefly in frequent flashes of happy illustration, a keen, sarcastic humour chastened but of deliberate purpose not altogether repressed, a direct forcible style, a commanding presence, and a pleasant musical voice sufficiently account for his popularity. He was the pioneer in a much needed improvement of the forms of service in Nonconformist churches, and gave a special impulse to congregational psalmody by the publication of a book entitled *The Service of Song in the House of the Lord*. Of numerous other works the best known is his *Is it Possible to Make the Best of Both Worlds?* an expansion of a lecture delivered to young men in Exeter Hall, which attained a circulation of 30,000 copies within a year of its publication. A very happy specimen of his peculiar powers as an author is his *Money, a Popular Exposition in Rough Notes* (1864), which also had a large circulation.

BINTANG, one of the islands which mark the south side of the Strait of Singapore. The latter is the exit towards China and Siam of the great channel which we call the Straits of Malacca. Bintang lies between 104° 13'

and 104° 40' E. long., with a central latitude of 0° 52' N. It has an area of about 440 square miles, and is surrounded by many rocks and small islands, making navigation dangerous. The soil is not fertile, and much of it is swampy. The chief product is *gambir*, of which upwards of 4000 tons are annually exported, with pepper and some other spices and fruits. The island is a good deal visited by Malay and Chinese traders. The highest hill in it is 1385 feet high, and there are five rivers, but these navigable only by small boats.

Bintang is mentioned by Marco Polo under the name of *Pentam*, which is not far from the genuine Malay name *Bentén*, said to mean a half-moon, and to apply properly to the mountain just mentioned. The name appears on a mediæval Javanese inscription, as that of one of the numerous kingdoms conquered by the sovereigns reigning at Majapahit, in Java.

After the Portuguese conquest of Malacca (1511), the expelled Mahometan dynasty took up its residence on Bintang, where it long cherished pirates. The island still belongs nominally to the representative of these kings of Malacca, whom we usually style the sultan of Johór, the Dutch the sultan of Lingen. Supremacy is, however, claimed and exercised by the Dutch, whose port of *Bêlo* or *Riouw*, founded as a rival to Singapore, stands on a small island off the western coast of Bintang.

Bintang, regarded as the residence of the expelled sultans of Malacca, is the Bintang whereof Camoens speaks as the persistent foe of Portuguese Malacca —

"No reino de Bintão, que tantos danos  
Terá a Malaca muito tempo feitos."

## B I O L O G Y

**T**HE Biological sciences are those which deal with the phenomena manifested by living matter; and though it is customary and convenient to group apart such of these phenomena as are termed mental, and such of them as are exhibited by men in society, under the heads of Psychology and Sociology, yet it must be allowed that no natural boundary separates the subject matter of the latter sciences from that of Biology. Psychology is inseparably linked with Physiology; and the phases of social life exhibited by animals other than man, which sometimes curiously foreshadow human policy, fall strictly within the province of the biologist.

On the other hand, the biological sciences are sharply marked off from the abiological, or those which treat of the phenomena manifested by not-living matter, in so far as the properties of living matter distinguish it absolutely from all other kinds of things, and as the present state of knowledge furnishes us with no link between the living and the not-living.

These distinctive properties of living matter are—

1. Its *chemical composition*—containing, as it invariably does, one or more forms of a complex compound of carbon, hydrogen, oxygen, and nitrogen, the so-called protein (which has never yet been obtained except as a product of living bodies) united with a large proportion of water, and forming the chief constituent of a substance which, in its primary unmodified state, is known as *protoplasm*.

2. Its *universal disintegration and waste by oxidation; and its concomitant reintegration by the intus-susception of new matter*.

A process of waste resulting from the decomposition of the molecules of the protoplasm, in virtue of which they break up into more highly oxidated products, which cease to form any part of the living body, is a constant concomitant of life. There is reason to believe that carbonic acid is always one of these waste products, while the others contain the remainder of the carbon, the nitrogen, the hydrogen, and the other elements which may enter into the composition of the protoplasm.

The new matter taken in to make good this constant

loss is either a ready-formed protoplasmic material, supplied by some other living being, or it consists of the elements of protoplasm, united together in simpler combinations, which consequently have to be built up into protoplasm by the agency of the living matter itself. In either case, the addition of molecules to those which already existed takes place, not at the surface of the living mass, but by interposition between the existing molecules of the latter. If the processes of disintegration and of reconstruction which characterize life balance one another, the size of the mass of living matter remains stationary, while, if the reconstructive process is the more rapid, the living body *grows*. But the increase of size which constitutes growth is the result of a process of molecular intus-susception, and therefore differs altogether from the process of growth by accretion, which may be observed in crystals and is effected purely by the external addition of new matter—so that, in the well-known aphorism of Linnæus, the word "grow," as applied to stones, signifies a totally different process from what is called "growth" in plants and animals.

3. Its *tendency to undergo cyclical changes*.

In the ordinary course of nature, all living matter proceeds from pre-existing living matter, a portion of the latter being detached and acquiring an independent existence. The new form takes on the characters of that from which it arose; exhibits the same power of propagating itself by means of an offshoot; and, sooner or later, like its predecessor, ceases to live, and is resolved into more highly oxidated compounds of its elements.

Thus an individual living body is not only constantly changing its substance, but its size and form are undergoing continual modifications, the end of which is the death and decay of that individual; the continuation of the kind being secured by the detachment of portions which tend to run through the same cycle of forms as the parent. No forms of matter which are either not living, or have not been derived from living matter, exhibit these three properties, nor any approach to the remarkable phenomena defined under the second and third heads. But in addition to these distinctive characters, living matter has some

other peculiarities, the chief of which are the dependence of all its activities upon moisture and upon heat, within a limited range of temperature, and the fact that it usually possesses a certain structure, or organization.

As has been said, a large proportion of water enters into the composition of all living matter; a certain amount of drying arrests vital activity, and the complete abstraction of this water is absolutely incompatible with either actual or potential life. But many of the simpler forms of life may undergo desiccation to such an extent as to arrest their vital manifestations and convert them into the semblance of not-living matter, and yet remain potentially alive. That is to say, on being duly moistened they return to life again. And this revivification may take place after months, or even years, of arrested life.

The properties of living matter are intimately related to temperature. Not only does exposure to heat sufficient to decompose protein matter destroy life, by demolishing the molecular structure upon which life depends; but all vital activity, all phenomena of nutritive growth, movement, and reproduction are possible only between certain limits of temperature. As the temperature approaches these limits the manifestations of life vanish, though they may be recovered by return to the normal conditions; but if it pass far beyond these limits, death takes place.

This much is clear; but it is not easy to say exactly what the limits of temperature are, as they appear to vary in part with the kind of living matter, and in part with the conditions of moisture which obtain along with the temperature. The conditions of life are so complex in the higher organisms, that the experimental investigation of this question can be satisfactorily attempted only in the lowest and simplest forms. It appears that, in the dry state, these are able to bear far greater extremes both of heat and cold than in the moist condition. Thus Pasteur found that the spores of fungi when dry, could be exposed without destruction to a temperature of 120°-125° C. (248°-257° Fahr.), while the same spores, when moist, were all killed by exposure to 100° C. (212° Fahr.) On the other hand, Cagniard de la Tour found that dry yeast might be exposed to the extremely low temperature of solid carbonic acid (-60° C. or -76° Fahr.) without being killed. In the moist state he found that it might be frozen and cooled to -5° C. (23° Fahr.), but that it was killed by lower temperatures. However, it is very desirable that these experiments should be repeated, for Cohn's careful observations on *Bacteria* show that, though they fall into a state of torpidity, and, like yeast, lose all their powers of exciting fermentation at, or near, the freezing point of water, they are not killed by exposure for five hours to a temperature below -10° C. (14° Fahr.), and, for some time, sinking to 18° C. (-0.4° Fahr.); specimens of *Spirillum volutans*, which had been cooled to this extent, began to move about some little time after the ice containing them thawed. But Cohn remarks that *Euglena*, which were frozen along with them, were all killed and disorganized, and that the same fate had befallen the higher *Infusoria* and *Rotifera*, with the exception of some encysted *Vorticella*, in which the rhythmical movements of the contractile vesicle showed that life was preserved.

Thus it would appear that the resistance of living matter to cold depends greatly on the special form of that matter, and that the limit of the *Euglena*, simple organism as it is, is much higher than that of the *Bacterium*.

Considerations of this kind throw some light upon the apparently anomalous conditions under which many of the lower plants, such as *Protozoons* and the *Diatomaceae*, and some of the lower animals, such as the *Radiolaria*, are observed to flourish. *Protozoons* has been found, not only

on the snows of great heights in temperate latitudes, but covering extensive areas of ice and snow in the Arctic regions, where it must be exposed to extremely low temperatures,—in the latter case for many months together; while the Arctic and Antarctic seas swarm with *Diatomaceae* and *Radiolaria*. It is on the *Diatomaceae*, as Hooker has well shown, that all surface life in these regions ultimately depends; and their enormous multitudes prove that their rate of multiplication is adequate to meet the demands made upon them, and is not seriously impeded by the low temperature of the waters, never much above the freezing point, in which they habitually live.

The maximum limit of heat which living matter can resist is no less variable than its minimum limit. Kühne found that marine *Amoeba* were killed when the temperature reached 35° C. (95° Fahr.), while this was not the case with fresh-water *Amoeba*, which survived a heat of 5°, or even 10°, C. higher. And *Actinophrys Eickhornii* was not killed until the temperature rose to 44° or 45° C. *Didymium serpylla* is killed at 35° C.; while another *Myxomycete*, *Ethalium septisium*, succumbs only at 40° C.

Cohn ("Untersuchungen über Bacterien," *Beiträge zur Biologie der Pflanzen*, Heft 2, 1872) has given the results of a series of experiments conducted with the view of ascertaining the temperature at which *Bacteria* are destroyed, when living in a fluid of definite chemical composition, and free from all such complications as must arise from the inequalities of physical condition when solid particles other than the *Bacteria* co-exist with them. The fluid employed contained 0.1 gramme potassium-phosphate, 0.1 gr. crystallised magnesium sulphate, 0.1 gr. tribasic calcium phosphate, and 0.2 gr. ammonium tartrate, dissolved in 20 cubic centimetres of distilled water. If to a certain quantity of this "normal fluid" a small proportion of water containing *Bacteria* was added, the multiplication of the *Bacteria* went on with rapidity, whether the mouth of the containing flask was open or hermetically closed. Hermetically-sealed flasks, containing portions of the normal fluid infected with *Bacteria*, were submerged in water heated to various temperatures, the flask being carefully shaken, without being raised out of the water, during its submergence.

The result was, that in those flasks which were thus subjected, for an hour, to a heat of 60°-62° C. (140°-143° Fahr.), the *Bacteria* underwent no development, and the fluid remained perfectly clear. On the other hand, in similar experiments in which the flasks were heated only to 40° or 50° C. (104°-122° Fahr.), the fluid became turbid, in consequence of the multiplication of the *Bacteria*, in the course of from two to three days.

Both in Kühne's and in Cohn's experiments, which last have lately been confirmed and extended by Dr Roberts of Manchester, it was noted that long exposure to a lower temperature than that which brings about immediate destruction of life, produces the same effect as short exposure to the latter temperature. Thus, though all the *Bacteria* were killed, with certainty, in the normal fluid, by short exposure to temperatures at or above 60° C. (140° Fahr.), Cohn observed that, when a flask containing infected normal fluid was heated to 50°-52° C. (122°-125° Fahr.) for only an hour, the consequent multiplication of the *Bacteria* was manifested much earlier, than in one which had been exposed for two hours to the same temperature.

It appears to be very generally held that the simpler vegetable organisms are deprived of life at temperatures as high as 80° C. (170° Fahr.); but *Algae* have been found living in hot springs at much higher temperatures, namely, from 168° to 208° Fahr., for which latter surprising fact we have the high authority of Desclouzeaux. It is no ex-



planation of these phenomena, but only another mode of stating them, to say that these organisms have become "accustomed" to such temperatures. If this degree of heat were absolutely incompatible with the activity of living matter, the plants could no more resist it than they could become "accustomed" to being made red hot. Habit may modify subsidiary, but cannot affect fundamental, conditions.

Recent investigations point to the conclusion that the immediate cause of the arrest of vitality, in the first place, and of its destruction, in the second, is the coagulation of certain substances in the protoplasm, and that the latter contains various coagulable matters, which solidify at different temperatures. And it remains to be seen, how far the death of any form of living matter, at a given temperature, depends on the destruction of its fundamental substance at that heat, and how far death is brought about by the coagulation of merely accessory compounds.

It may be safely said of all those living things which are large enough to enable us to trust the evidence of microscopes, that they are heterogeneous optically, and that their different parts, and especially the surface layer, as contrasted with the interior, differ physically and chemically; while, in most living things, mere heterogeneity is exchanged for a definite structure, whereby the body is distinguished into visibly different parts, which possess different powers or functions. Living things which present this visible structure are said to be *organised*; and so widely does organisation obtain among living beings, that *organised* and *living* are not unfrequently used as if they were terms of co-extensive applicability. This, however, is not exactly accurate, if it be thereby implied that all living things have a visible organization, as there are numerous forms of living matter of which it cannot properly be said that they possess either a definite structure or permanently specialized organs: though, doubtless, the simplest particle of living matter must possess a highly complex molecular structure, which is far beyond the reach of vision.

The broad distinctions which, as a matter of fact, exist between every known form of living substance and every other component of the material world, justify the separation of the biological sciences from all others. But it must not be supposed that the differences between living and not-living matter are such as to justify the assumption that the forces at work in the one are different from those which are to be met with in the other. Considered apart from the phenomena of consciousness, the phenomena of life are all dependent upon the working of the same physical and chemical forces as those which are active in the rest of the world. It may be convenient to use the terms "vitality" and "vital force" to denote the causes of certain great groups of natural operations, as we employ the names of "electricity" and "electrical force" to denote others; but it ceases to be proper to do so, if such a name implies the absurd assumption that "electricity" and "vitality" are entities playing the part of efficient causes of electrical or vital phenomena. A mass of living protoplasm is simply a molecular machine of great complexity, the total results of the working of which, or its vital phenomena, depend,—on the one hand, upon its construction, and, on the other, upon the energy supplied to it; and to speak of "vitality" as anything but the name of a series of operations is as if one should talk of the "horology" of a clock.

Living matter, or protoplasm and the products of its metamorphosis, may be regarded under four aspects:—

- (1.) It has a certain external and internal form, the latter being more usually called structure;
- (2.) It occupies a certain position in space and in time;
- (3.) It is the subject of the operation of certain forces,

in virtue of which it undergoes internal changes, modifies external objects, and is modified by them; and

- (4.) Its form, place, and powers are the effects of certain causes.

In correspondence with these four aspects of its subject, biology is divisible into four chief subdivisions—I. MORPHOLOGY; II. DISTRIBUTION; III. PATHOLOGY; IV. *ÆTIOLOGY*.

### I. MORPHOLOGY.

So far as living beings have a form and structure, they fall within the province of *Anatomy* and *Histology*, the latter being merely a name for that ultimate optical analysis of living structure which can be carried out only by the aid of the microscope.

And, in so far as the form and structure of any living being are not constant during the whole of its existence but undergo a series of changes from the commencement of that existence to its end, living beings have a *Development*. The history of development is an account of the anatomy of a living being at the successive periods of its existence, and of the manner in which one anatomical stage passes into the next.

Finally, the systematic statement and generalization of the facts of Morphology, in such a manner as to arrange living beings in groups according to their degrees of likeness, is *Taxonomy*.

The study of Anatomy and Development has brought to light certain generalizations of wide applicability and great importance.

1. It has been said that the great majority of living beings present a very definite structure. Unassisted vision and ordinary dissection suffice to separate the body of any of the higher animals, or plants, into fabrics of different sorts, which always present the same general arrangement in the same organism, but are combined in different ways in different organisms. The discrimination of these comparatively few fabrics, or *tissues*, of which organisms are composed, was the first step towards that ultimate analysis of visible structure which has become possible only by the recent perfection of microscopes and of methods of preparation.

Histology, which embodies the results of this analysis, shows that every tissue of a plant is composed of more or less modified structural elements, each of which is termed a *cell*; which cell, in its simplest condition, is merely a spheroidal mass of protoplasm, surrounded by a coat or sac—the *cell-wall*—which contains cellulose. In the various tissues, these cells may undergo innumerable modifications of form—the protoplasm may become differentiated into a nucleus with its nucleolus, a primordial utricle, and a cavity filled with a watery fluid, and the cell-wall may be variously altered in composition or in structure, or may coalesce with others. But, however extensive these changes may be, the fact that the tissues are made up of morphologically distinct units—the cells—remains patent. And, if any doubt could exist on the subject, it would be removed by the study of development, which proves that every plant commences its existence as a simple cell, identical in its fundamental characters with the less modified of those cells of which the whole body is composed.

But it is not necessary to the morphological unit of the plant that it should be always provided with a cell-wall. Certain plants, such as *Protococcus*, spend longer or shorter periods of their existence in the condition of a mere spheroid of protoplasm, devoid of any cellulose wall, while, at other times, the protoplasmic body becomes enclosed within a cell-wall, fabricated by its superficial layer.

Therefore, just as the nucleus, the primordial utricle, and the central fluid are no essential constituents of the

morphological unit of the plant, but represent results of its metamorphosis, so the cell-wall is equally unessential; and either the term "cell" must acquire a merely technical significance as the equivalent of morphological unit, or some new term must be invented to describe the latter. On the whole, it is probably least inconvenient to modify the sense of the word "cell."

The histological analysis of animal tissues has led to results and to difficulties of terminology of precisely the same character. In the higher animals, however, the modifications which the cells undergo are so extensive, that the fact that the tissues are, as in plants, resolvable into an aggregation of morphological units, could never have been established without the aid of the study of development, which proves that the animal, no less than the plant, commences its existence as a simple cell, fundamentally identical with the less modified cells which are found in the tissues of the adult.

Though the nucleus is very constant among animal cells, it is not universally present; and among the lowest forms of animal life, the protoplasmic mass which represents the morphological unit may be, as in the lowest plants, devoid of a nucleus. In the animal, the cell-wall never has the character of a *shtet sac* containing cellulose; and it is not a little difficult, in many cases, to say how much of the so-called "cell-wall" of the animal cell answers to the "primordial utricle" and how much to the proper "cellulose cell-wall" of the vegetable cell. But it is certain that in the animal, as in the plant, neither cell-wall nor nucleus are essential constituents of the cell, inasmuch as bodies which are unquestionably the equivalents of cells—true morphological units—are mere masses of protoplasm, devoid alike of cell-wall and nucleus.

For the whole living world, then, it results:—that the morphological unit—the primary and fundamental form of life—is merely an individual mass of protoplasm, in which no further structure is discernible; that independent living forms may present but little advance on this structure; and that all the higher forms of life are aggregates of such morphological units or cells, variously modified.

Moreover, all that is at present known tends to the conclusion, that, in the complex aggregates of such units of which all the higher animals and plants consist, no cell has arisen otherwise than by becoming separated from the protoplasm of a pre-existing cell; whence the aphorism "*Omnis cellula e cellula*."

It may further be added, as a general truth applicable to nucleated cells, that the nucleus rarely undergoes any considerable modification, the structures characteristic of the tissues being formed at the expense of the more superficial protoplasm of the cells; and that, when nucleated cells divide, the division of the nucleus, as a rule, precedes that of the whole cell.

2. In the course of its development every cell proceeds from a condition in which it closely resembles every other cell, through a series of stages of gradually increasing divergence, until it reaches that condition in which it presents the characteristic features of the elements of a special tissue. The development of the cell is therefore a gradual progress from the general to the special state.

The like holds good of the development of the body as a whole. However complicated one of the higher animals or plants may be, it begins its separate existence under the form of a nucleated cell. This, by division, becomes converted into an aggregate of nucleated cells: the parts of this aggregate, following different laws of growth and multiplication, give rise to the rudiments of the organs; and the parts of these rudiments again take on those modes of growth and multiplication and metamorphosis which are needful to convert the rudiment into the perfect structure.

The development of the organism as a whole, therefore, repeats in principle the development of the cell. It is a progress from a general to a special form, resulting from the gradual differentiation of the primitively similar morphological units of which the body is composed.

Moreover, when the stages of development of two animals are compared, the number of these stages which are similar to one another is, as a general rule, proportional to the closeness of the resemblance of the adult forms; whence it follows that the more closely any two animals are allied in adult structure, the later are their embryonic conditions distinguishable. And this general rule holds for plants no less than for animals.

The broad principle, that the form in which the more complex living things commence their development is always the same, was first expressed by Harvey in his famous aphorism, "*Omnis vivum ex ovo*," which was intended simply as a morphological generalization, and in no wise implied the rejection of spontaneous generation, as it is commonly supposed to do. Moreover, Harvey's study of the development of the chick led him to promulgate that theory of "epigenesis," in which the doctrine that development is a progress from the general to the special is implicitly contained.

Caspar F. Wolff furnished further, and indeed conclusive, proof of the truth of the theory of epigenesis; but, unfortunately, the authority of Haller and the speculations of Bonnet led science astray, and it was reserved for Von Baer to put the nature of the process of development in its true light, and to formulate it in his famous law.

3. Development, then, is a process of differentiation by which the primitively similar parts of the living body become more and more unlike one another.

This process of differentiation may be effected in several ways.

(1.) The protoplasm of the germ may not undergo division and conversion into a cell aggregate; but various parts of its outer and inner substance may be metamorphosed directly into those physically and chemically different materials which constitute the body of the adult. This occurs in such animals as the *Infusoria*, and in such plants as the unicellular *Alga*.

(2.) The germ may undergo division, and be converted into an aggregate of cells, which cells give rise to the tissues by undergoing a metamorphosis of the same kind as that to which the whole body is subjected in the preceding case.

The body, formed in either of these ways, may, as a whole, undergo metamorphosis by differentiation of its parts, and the differentiation may take place without reference to any axis of symmetry, or it may have reference to such an axis. In the latter case, the parts of the body which become distinguishable may correspond on the two sides of the axis (bilateral symmetry), or may correspond along several lines parallel with the axis (radial symmetry).

The bilateral or radial symmetry of the body may be further complicated by its segmentation, or separation by divisions transverse to the axis, into parts, each of which corresponds with its predecessor or successor in the series.

In the segmented body, the segments may or may not give rise to symmetrically or asymmetrically disposed processes, which are *appendages*, using that word in its most general sense.

And the highest degree of complication of structure, in both animals and plants, is attained by the body when it becomes divided into segments provided with appendages; when the segments not only become very different from one another, but some coalesce and lose their primitive distinctness; and when the appendages and the segments into

which they are subdivided similarly become differentiated and coalesce.

It is in virtue of such processes that the flowers of plants, and the heads and limbs of the *Artropoda* and of the *Vertebrata*, among animals, attain their extraordinary diversity and complication of structure. A flower-bud is a segmented body or axis, with a certain number of whorls of appendages; and the perfect flower is the result of the gradual differentiation and confluence of these primitively similar segments and their appendages. The head of an insect or of a crustacean is, in like manner, composed of a number of segments, each with its pair of appendages, which by differentiation and confluence are converted into the feelers and variously modified oral appendages of the adult.

In some complex organisms, the process of differentiation, by which they pass from the condition of aggregated embryo cells to the adult, can be traced back to the laws of growth of the two or more cells into which the embryo cell is divided, each of these cells giving rise to a particular portion of the adult organism. Thus the fertilized embryo cell in the archegonium of a fern divides into four cells, one of which gives rise to the rhizome of the young fern, another to its first rootlet, while the other two are converted into a placenta-like mass which remains embedded in the prothallus.

The structure of the stem of *Chara* depends upon the different properties of the cells, which are successively derived by transverse division from the apical cell. An *inter-nodal* cell, which elongates greatly, and does not divide, is succeeded by a *nodal* cell, which elongates but little, and becomes greatly subdivided; this by another *inter-nodal* cell, and so on in regular alternation. In the same way the structure of the stem, in all the higher plants, depends upon the laws which govern the manner of division and of metamorphosis of the apical cells, and of their continuation in the *camhium* layer.

In all animals which consist of cell-aggregates, the cells of which the embryo is at first composed arrange themselves by the splitting, or by a process of invagination, of the blastoderm into two layers, the *epiblast* and the *hypoblast*, between which a third intermediate layer, the *mesoblast*, appears, and each layer gives rise to a definite group of organs in the adult. Thus, in the *Vertebrata*, the epiblast gives rise to the cerebro-spinal axis, and to the epidermis and its derivatives; the hypoblast, to the epithelium of the alimentary canal and its derivatives; and the mesoblast, to all the intermediate structures. The tendency of recent inquiry is to prove that the several layers of the germ evolve analogous organs in invertebrate animals, and to indicate the possibility of tracing the several germ layers back to the blastomeres of the yolk, from the subdivision of which they proceed.

It is conceivable that all the forms of life should have presented about the same differentiation of structure, and should have differed from one another by superficial characters, each form passing by insensible gradations into those most like it. In this case Taxonomy, or the classification of morphological facts, would have had to confine itself to the formation of a serial arrangement representing the serial gradation of these forms in nature.

It is conceivable, again, that living beings should have differed as widely in structure as they actually do, but that the interval between any two extreme forms should have been filled up by an unbroken series of gradations; in which case, again, classification could only effect the formation of series—the strict definition of groups would be as impossible as in the former case.

As a matter of fact, living beings differ enormously, not

only in differentiation of structure, but in the modes in which that differentiation is brought about; and the intervals between extreme forms are not filled up in the existing world by complete series of gradations. Hence it arises that living beings are, to a great extent, susceptible of classification into groups, the members of each group resembling one another, and differing from all the rest, by certain definite peculiarities.

No two living beings are exactly alike, but it is a matter of observation that, among the endless diversities of living things, some constantly resemble one another so closely that it is impossible to draw any line of demarcation between them, while they differ only in such characters as are associated with sex. Such as thus closely resemble one another constitute a *morphological species*; while different morphological species are defined by constant characters which are not merely sexual.

The comparison of these lowest groups, or morphological species, with one another, shows that more or fewer of them possess some character or characters in common—some feature in which they resemble one another and differ from all other species—and the group or higher order thus formed is a *genus*. The generic groups thus constituted are susceptible of being arranged in a similar manner into groups of successively higher order, which are known as *families*, *orders*, *classes*, and the like.

The method pursued in the classification of living forms is, in fact, exactly the same as that followed by the maker of an index in working out the heads indexed. In an alphabetical arrangement, the classification may be truly termed a morphological one, the object being to put into close relation all those leading words which resemble one another in the arrangement of their letters, that is, in their form, and to keep apart those which differ in structure. Headings which begin with the same word, but differ otherwise, might be compared to genera with their species; the groups of words with the same first two syllables to families; those with identical first syllables to orders; and those with the same initial letter to classes. But there is this difference between the index and the Taxonomic arrangement of living forms, that in the former there is none but an arbitrary relation between the various classes, while in the latter the classes are similarly capable of co-ordination into larger and larger groups, until all are comprehended under the common definition of living beings.

The differences between "artificial" and "natural" classifications are differences in degree, and not in kind. In each case the classification depends upon likeness; but in an artificial classification some prominent and easily observed feature is taken as the mark of resemblance or dissemblance; while, in a natural classification, the things classified are arranged according to the totality of their morphological resemblances, and the features which are taken as the marks of groups are those which have been ascertained by observation to be the indications of many likenesses or unlikenesses. And thus a natural classification is a great deal more than a mere index. It is a statement of the marks of similarity of organization; of the kinds of structure which, as a matter of experience, are found universally associated together; and, as such, it furnishes the whole foundation for those indications by which conclusions as to the nature of the whole of an animal are drawn from a knowledge of some part of it.

When a paleontologist argues from the characters of a bone or of a shell to the nature of the animal to which that bone or shell belonged, he is guided by the empirical morphological laws established by wide observation, that such a kind of bone or shell is associated with such and such structural features in the rest of the body, and no

others. And it is these empirical laws which are embodied and expressed in a natural classification.

## II. DISTRIBUTION.

Living beings occupy certain portions of the surface of the earth, inhabiting either the dry land or the fresh or salt waters, or being competent to maintain their existence in either. In any given locality, it is found that those different media are inhabited by different kinds of living beings; and that the same medium, at different heights in the air and at different depths in the water, has different living inhabitants.

Moreover, the living populations of localities which differ considerably in latitude, and hence in climate, always present considerable differences. But the converse proposition is not true; that is to say, localities which differ in longitude, even if they resemble one another in climate, often have very dissimilar faunas and floras.

It has been discovered by careful comparison of local faunas and floras that certain areas of the earth's surface are inhabited by groups of animals and plants which are not found elsewhere, and which thus characterize each of these areas. Such areas are termed *Provinces of Distribution*. There is no parity between these provinces in extent, nor in the physical configuration of their boundaries; and, in reference to existing conditions, nothing can appear to be more arbitrary and capricious than the distribution of living beings.

The study of distribution is not confined to the present order of nature; but, by the help of geology, the naturalist is enabled to obtain clear, though too fragmentary, evidence of the characters of the faunas and floras of antecedent epochs. The remains of organisms which are contained in the stratified rocks prove that, in any given part of the earth's surface, the living population of earlier epochs was different from that which now exists in the locality; and that, on the whole, the difference becomes greater the farther we go back in time. The organic remains which are found in the later Cainozoic deposits of any district are always closely allied to those now found in the province of distribution in which that locality is included; while in the older Cainozoic, the Mesozoic, and the Palaeozoic strata, the fossils may be similar to creatures at present living in some other province, or may be altogether unlike any which now exist.

In any given locality, the succession of living forms may appear to be interrupted by numerous breaks—the associated species in each fossiliferous bed being quite distinct from those above and those below them. But the tendency of all palaeontological investigation is to show that these breaks are only apparent, and arise from the incompleteness of the series of remains which happens to have been preserved in any given locality. As the area over which accurate geological investigations have been carried on extends, and as the fossiliferous rocks found in one locality fill up the gaps left in another, so do the abrupt demarcations between the faunas and floras of successive epochs disappear—a certain proportion of the genera and species of every period, great or small, being found to be continued for a longer or shorter time into the next succeeding period. It is evident, in fact, that the changes in the living population of the globe which have taken place during its history, have been effected, not by the sudden replacement of one set of living beings by another, but by a process of slow and gradual introduction of new species, accompanied by the extinction of the older forms.

It is a remarkable circumstance, that in all parts of the globe in which fossiliferous rocks have yet been examined, the successive terms of the series of living forms which

have thus succeeded one another are analogous. The life of the Mesozoic epoch is everywhere characterized by the abundance of some groups of species of which no trace is to be found in either earlier or later formations; and the like is true of the Palaeozoic epoch. Hence it follows, not only that there has been a succession of species, but that the general nature of that succession has been the same all over the globe; and it is on this ground that fossils are so important to the geologist as marks of the relative age of rocks.

The determination of the morphological relations of the species which have thus succeeded one another is a problem of profound importance and difficulty, the solution of which, however, is already clearly indicated. For, in several cases, it is possible to show that, in the same geographical area, a form A, which existed during a certain geological epoch, has been replaced by another form B, at a later period; and that this form B has been replaced, still later, by a third form C. When these forms, A, B, and C, are compared together they are found to be organized upon the same plan, and to be very similar even in most of the details of their structure; but B differs from A by a slight modification of some of its parts, which modification is carried to a still greater extent in C.

In other words, A, B, and C differ from one another in the same fashion as the earlier and later stages of the embryo of the same animals differ; and in successive epochs we have the group presenting that progressive specialisation which characterises the development of the individual. Clear evidence that this progressive specialisation of structure has actually occurred has as yet been obtained in only a few cases (*e.g.*, *Equidae*, *Crocodylia*), and these are confined to the highest and most complicated forms of life; while it is demonstrable that, even as reckoned by geological time, the process must have been exceedingly slow.

Among the lower and less complicated forms the evidence of progressive modifications, furnished by comparison of the oldest with the latest forms, is slight, or absent; and some of these have certainly persisted, with very little change, from extremely ancient times to the present day. It is as important to recognize the fact that certain forms of life have thus persisted, as it is to admit that others have undergone progressive modification.

It has been said that the successive terms in the series of living forms are analogous in all parts of the globe. But the species which constitute the corresponding or *homotaxic* terms in the series, in different localities, are not identical. And, though the imperfection of our knowledge at present precludes positive assertion, there is every reason to believe that geographical provinces have existed throughout the period during which organic remains furnish us with evidence of the existence of life. The wide distribution of certain Palaeozoic forms does not militate against this view; for the recent investigations into the nature of the deep-sea fauna have shown that numerous *Crustacea*, *Echinodermata*, and other invertebrate animals, have as wide a distribution now as their analogues possessed in the Silurian epoch.

## III. PHYSIOLOGY.

Thus far living beings have been regarded merely as definite forms of matter, and Biology has presented no considerations of a different order from those which meet the student of Mineralogy. But living things are not only natural bodies, having a definite form and mode of structure, growth, and development. They are machines in action; and, under this aspect, the phenomena which they present have no parallel in the mineral world.

The actions of living matter are termed its *functions*; and these functions, varied as they are, may be reduced to

three categories. They are either—(1), functions which affect the material composition of the body, and determine its mass, which is the balance of the processes of waste on the one hand and those of assimilation on the other. Or (2), they are functions which subserve the process of reproduction, which is essentially the detachment of a part endowed with the power of developing into an independent whole. Or (3), they are functions in virtue of which one part of the body is able to exert a direct influence on another, and the body, by its parts or as a whole, becomes a source of molar motion. The first may be termed *sustentative*, the second *generative*, and the third *correlative* functions.

Of these three classes of functions the first two only can be said to be invariably present in living beings, all of which are nourished, grow, and multiply. But there are some forms of life, such as many *Fungi*, which are not known to possess any powers of changing their form; in which the protoplasm exhibits no movements, and reacts upon no stimulus; and in which any influence which the different parts of the body exert upon one another must be transmitted indirectly from molecule to molecule of the common mass. In most of the lowest plants, however, and in all animals yet known, the body either constantly or temporarily changes its form, either with or without the application of a special stimulus, and thereby modifies the relations of its parts to one another, and of the whole to surrounding bodies; while, in all the higher animals, the different parts of the body are able to affect, and be affected by, one another, by means of a special tissue, termed *nerve*. Molar motion is effected on a large scale by means of another special tissue, *muscle*; and the organism is brought into relation with surrounding bodies by means of a third kind of special tissue—that of the *sensory organs*—by means of which the forces exerted by surrounding bodies are transmuted into affections of nerve.

In the lowest forms of life, the functions which have been enumerated are seen in their simplest forms, and they are exerted indifferently, or nearly so, by all parts of the protoplasmic body; and the like is true of the functions of the body of even the highest organisms, so long as they are in the condition of the nucleated cell, which constitutes the starting point of their development. But the first process in that development is the division of the germ into a number of morphological units or blastomeres, which, eventually, give rise to cells; and as each of these possesses the same physiological functions as the germ itself, it follows that each morphological unit is also a physiological unit, and the multicellular mass is strictly a compound organism, made up of a multitude of physiologically independent cells. The physiological activities manifested by the complex whole represent the sum, or rather the resultant; of the separate and independent physiological activities resident in each of the simpler constituents of that whole.

The morphological changes which the cells undergo in the course of the further development of the organism do not affect their individuality; and, notwithstanding the modification and confluence of its constituent cells, the adult organism, however complex, is still an aggregate of morphological units. Nor is it less an aggregate of physiological units, each of which retains its fundamental independence, though that independence becomes restricted in various ways.

Each cell, or that element of a tissue which proceeds from the modification of a cell, must needs retain its sustentative functions so long as it grows or maintains a condition of equilibrium; but the most completely metamorphosed cells show no trace of the generative function, and many exhibit no correlative functions. On the other

hand, those cells of the adult organism which are the unmetamorphosed derivatives of the germ, exhibit all the primary functions, not only nourishing themselves and growing, but multiplying, and frequently showing more or less marked movements.

*Organs* are parts of the body which perform particular functions. In strictness, perhaps, it is not quite right to speak of organs of sustentation or generation, each of these functions being necessarily performed by the morphological unit which is nourished or reproduced. What are called the organs of these functions are the apparatuses by which certain operations, subsidiary to sustentation and generation, are carried on.

Thus, in the case of the sustentative functions, all those organs may be said to contribute to this function which are concerned in bringing nutriment within reach of the ultimate cells, or in removing waste matter from them; while in the case of the generative function, all those organs contribute to the function which produces the cells from which germs are given off; or help in the evacuation, or fertilization, or development of these germs.

On the other hand, the correlative functions, so long as they are exerted by a simple undifferentiated morphological unit or cell, are of the simplest character, consisting of those modifications of position which can be affected by mere changes in the form or arrangement of the parts of the protoplasm, or of those prolongations of the protoplasm which are called pseudopodia or cilia. But, in the higher animals and plants, the movements of the organism and of its parts are brought about by the change of the form of certain tissues, the property of which is to shorten in one direction when exposed to certain stimuli. Such tissues are termed *contractile*; and, in their most fully developed condition, *muscular*. The stimulus by which this contraction is naturally brought about is a molecular change, either in the substance of the contractile tissue itself, or in some other part of the body; in which latter case, the motion which is set up in that part of the body must be propagated to the contractile tissue through the intermediate substance of the body. In plants there seems to be no question that parts which retain a hardly modified cellular structure may serve as channels for the transmission of this molecular motion: whether the same is true of animals is not certain. But, in all the more complex animals, a peculiar fibrous tissue—*nerve*—serves as the agent by which contractile tissue is affected by changes occurring elsewhere, and by which contractions thus initiated are co-ordinated and brought into harmonious combination. While the sustentative functions in the higher forms of life are still, as in the lower, fundamentally dependent upon the powers inherent in all the physiological units which make up the body, the correlative functions are, in the former, deputed to two sets of specially modified units, which constitute the muscular and the nervous tissues.

When the different forms of life are compared together as physiological machines, they are found to differ as machines of human construction do. In the lower forms, the mechanism, though perfectly well adapted to do the work for which it is required, is rough, simple, and weak; while, in the higher, it is finished, complicated, and powerful. Considered as machines, there is the same sort of difference between a polype and a horse as there is between a distaff and a spinning-jenny. In the progress from the lower to the higher organism, there is a gradual differentiation of organs and of functions. Each function is separated into many parts, which are severally entrusted to distinct organs. To use the striking phrase of Milne-Edwards, in passing from low to high organisms, there is a division of physiological labour. And exactly the same process is observable in the development of any of the higher organ-

isms; so that, physiologically, as well as morphologically, development is a progress from the general to the special.

Thus far, the physiological activities of living matter have been considered in themselves, and without reference to anything that may affect them in the world outside the living body. But living matter acts on, and is powerfully affected by, the bodies which surround it; and the study of the influence of the "conditions of existence" thus determined constitutes a most important part of Physiology.

The sustentative functions, for example, can only be exerted under certain conditions of temperature, pressure, and light, in certain media, and with supplies of particular kinds of nutritive matter; the sufficiency of which supplies, again, is greatly influenced by the competition of other organisms, which, striving to satisfy the same needs, give rise to the passive "struggle for existence." The exercise of the correlative functions is influenced by similar conditions, and by the direct conflict with other organisms, which constitutes the active struggle for existence. And, finally, the generative functions are subject to extensive modifications, dependent partly upon what are commonly called external conditions, and partly upon wholly unknown agencies.

In the lowest forms of life, the only mode of generation at present known is the division of the body into two or more parts, each of which then grows to the size and assumes the form of its parent, and repeats the process of multiplication. This method of multiplication by *fission* is properly called generation, because the parts which are separated are severally competent to give rise to individual organisms of the same nature as that from which they arise.

In many of the lowest organisms the process is modified so far that, instead of the parent dividing into two equal parts, only a small portion of its substance is detached, as a bud which develops into the likeness of its parent. This is generation by *gemmation*. Generation by fission and by gemmation are not confined to the simplest forms of life, however. On the contrary, both modes of multiplication are common not only among plants, but among animals of considerable complexity.

The multiplication of flowering plants by bulbs, that of annelids by fission, and that of polypes by budding, are well-known examples of these modes of reproduction. In all these cases, the bud or the segment consists of a multitude of more or less metamorphosed cells. But, in other instances, a single cell detached from a mass of such undifferentiated cells contained in the parental organism is the foundation of the new organism, and it is hard to say whether such a detached cell may be more fitly called a bud or a segment—whether the process is more akin to fission or to gemmation.

In all these cases the development of the new being from the detached germ takes place without the influence of other living matter. Common as the process is in plants and in the lower animals, it becomes rare among the higher animals. In these, the reproduction of the whole organism from a part, in the way indicated above, ceases. At most, we find that the cells at the end of an amputated portion of the organism are capable of reproducing the lost part; and, in the very highest animals, even this power vanishes in the adult; and, in most parts of the body, though the undifferentiated cells are capable of multiplication, their progeny grow, not into whole organisms like that of which they form a part, but into elements of the tissues.

Throughout almost the whole series of living beings, however, we find concurrently with the process of *agamogenesis*, or asexual generation, another method of generation, in which the development of the germ into an organism

resembling the parent depends on an influence exerted by living matter different from the germ. This is *gamogenesis*, or sexual generation. Looking at the facts broadly, and without reference to many exceptions in detail, it may be said that there is an inverse relation between *agamogenesis* and *gamogenetic* reproduction. In the lowest organisms *gamogenesis* has not yet been observed, while in the highest *agamogenesis* is absent. In many of the lower forms of life *agamogenesis* is the common and predominant mode of reproduction, while *gamogenesis* is exceptional; on the contrary, in many of the higher, while *gamogenesis* is the rule, *agamogenesis* takes place exceptionally. In its simplest condition, which is termed "*conjugation*," sexual generation consists in the coalescence of two similar masses of protoplasmic matter, derived from different parts of the same organism, or from two organisms of the same species, and the single mass which results from the fusion develops into a new organism.

In the majority of cases, however, there is a marked morphological difference between the two factors in the process, and then one is called the male, and the other the female element. The female element is relatively large, and undergoes but little change of form. In all the higher plants and animals it is a nucleated cell, to which a greater or less amount of nutritive material, constituting the food-yolk, may be added.

The male element, on the other hand, is relatively small. It may be conveyed to the female element by an outgrowth of the wall of its cell, which is short in many *Algae* and *Fungi*, but becomes an immensely elongated tubular filament, in the case of the pollen cell of flowering plants. But, more commonly, the protoplasm of the male cells becomes converted into rods or filaments, which usually are in active vibratile movement, and sometimes are propelled by numerous cilia. Occasionally, however, as in many *Nematoidea* and *Arthropoda*, they are devoid of mobility.

The manner in which the contents of the pollen tube affect the embryo cell in flowering plants is unknown, as no perforations through which the contents of the pollen tube may pass, so as actually to mix with the substance of the embryo cell, have been discovered; and there is the same difficulty with respect to the conjugative processes of some of the *Cryptogamia*. But in the great majority of plants, and in all animals, there can be no doubt that the substance of the male element actually mixes with that of the female, so that in all these cases the sexual process remains one of conjugation; and impregnation is the physical admixture of protoplasmic matter derived from two sources, which may be either different parts of the same organism, or different organisms.

The effect of impregnation appears in all cases to be that the impregnated protoplasm tends to divide into portions (*blastomeres*), which may remain united as a single cell-aggregate, or some or all of which may become separate organisms. A larger or shorter period of rest, in many cases, intervenes between the act of impregnation and the commencement of the process of division.

As a general rule, the female cell which directly receives the influence of the male is that which undergoes division and eventual development into independent germs; but there are some plants, such as the *Floridæ*, in which this is not the case. In these the protoplasmic body of the trichogyne, which unites with the molecular spermatozooids, does not undergo division itself, but transmits some influence to adjacent cells, in virtue of which they become subdivided into independent germs or spores.

There is still much obscurity respecting the reproductive processes of the *Infusoria*; but, in the *Verticellidæ*, it would appear that conjugation merely determines a condition of

the whole organism, which gives rise to the division of the endoplast or so-called nucleus, by which germs are thrown off; and if this be the case, the process would have some analogy to what takes place in the *Florida*.

On the other hand, the process of conjugation by which two distinct *Diporpes* combine into that extraordinary double organism, the *Diplazon paradoxum*, does not directly give rise to germs, but determines the development of the sexual organs in each of the conjugated individuals; and the same process takes place in a large number of the *Infusoria*, if what are supposed to be male sexual elements in them are really such.

The process of impregnation in the *Florida* is remarkably interesting, from its bearing upon the changes which fecundation is known to produce upon parts of the parental organism other than the ovum, even in the highest animals and plants.

The nature of the influence exerted by the male element upon the female is wholly unknown. No morphological distinction can be drawn between those cells which are capable of reproducing the whole organism without impregnation, and those which need it, as is obvious from what happens in insects, where eggs which ordinarily require impregnation, exceptionally, as in many moths, or regularly, as in the case of the drones among bees, develop without impregnation. Even in the higher animals, such as the fowl, the earlier stages of division of the germ may take place without impregnation.

In fact, generation may be regarded as a particular case of cell multiplication, and impregnation simply as one of the many conditions which may determine or affect that process. In the lowest organisms, the simple protoplasmic mass divides, and each part retains all the physiological properties of the whole, and consequently constitutes a germ whence the whole body can be reproduced. In more advanced organisms, each of the multitude of cells into which the embryo cell is converted at first, probably retains all, or nearly all, the physiological capabilities of the whole, and is capable of serving as a reproductive germ; but as division goes on, and many of the cells which result from division acquire special morphological and physiological properties, it seems not improbable that they, in proportion, lose their more general characters. In proportion, for example, as the tendency of a given cell to become a muscle cell or a cartilage cell is more marked and definite, it is readily conceivable that its primitive capacity to reproduce the whole organism should be reduced, though it might not be altogether abolished. If this view is well based, the power of reproducing the whole organism would be limited to those cells which had acquired no special tendencies, and consequently had retained all the powers of the primitive cell in which the organism commenced its existence. The more extensively diffused such cells were, the more generally might multiplication by budding or fission take place; the more localized, the more limited would be the parts of the organism in which such a process would take place. And even where such cells occurred, their development or non-development might be connected with conditions of nutrition. It depends on the nutriment supplied to the female larva of a bee whether it shall become a neuter or a sexually perfect female; and the sexual perfection of a large proportion of the internal parasites is similarly dependent upon their food, and perhaps on other conditions, such as the temperature of the medium in which they live. Thus the gradual disappearance of agamogenesis in the higher animals would be related with that increasing specialization of function which is their essential characteristic; and when it ceases to occur altogether, it may be supposed that no cells are left which retain unmodified the powers of the primitive embryo cell. The organism is like a society in which

every one is so engrossed by his special business that he has neither time nor inclination to marry.

Even the female elements in the highest organisms little as they differ to all appearance from undifferentiated cells, and though they are directly derived from epithelial cells which have undergone very little modification from the condition of blastomeres, are incapable of full development unless they are subjected to the influence of the male element, which may, as Caspar Wolf suggested, be compared to a kind of nutriment. But it is a living nutriment, in some respects comparable to that which would be supplied to an animal kept alive by transfusion, and its molecules transfer to the impregnated embryo cell all the special characters of the organism to which it belonged.

The tendency of the germ to reproduce the characters of its immediate parents, combined, in the case of sexual generation, with the tendency to reproduce the characters of the male, is the source of the singular phenomena of hereditary transmission. No structural modification is so slight, and no functional peculiarity is so insignificant in either parent that it may not make its appearance in the offspring. But the transmission of parental peculiarities depends greatly upon the manner in which they have been acquired. Such as have arisen naturally, and have been hereditary through many antecedent generations, tend to appear in the progeny with great force; while artificial modifications, such, for example, as result from mutilation, are rarely, if ever, transmitted. Circumcision through innumerable ancestral generations does not appear to have reduced that rite to a mere formality, as it should have done, if the abbreviated prepuce had become hereditary in the descendants of Abraham; while modern lambs are born with long tails, notwithstanding the long-continued practice of cutting those of every generation short. And it remains to be seen whether the supposed hereditary transmission of the habit of retrieving among dogs is really what it seems at first sight to be; on the other side, Brown-Séquard's case of the transmission of artificially induced epilepsy in guinea-pigs is undoubtedly very weighty.

Although the germ always tends to reproduce, directly or indirectly, the organism from which it is derived, the result of its development differs somewhat from the parent. Usually the amount of variation is insignificant; but it may be considerable, as in the so-called "sports;" and such variations, whether useful or useless, may be transmitted with great tenacity to the offspring of the subjects of them.

In many plants and animals which multiply both asexually and sexually, there is no definite relation between the agamogenetic and the gamogenetic phenomena. The organism may multiply asexually before, or after, or concurrently with, the occurrence of sexual generation.

But in a great many of the lower organisms, both animal and vegetable, the organism (A) which results from the impregnated germ produces offspring only agamogenetically. It thus gives rise to a series of independent organisms (B, B, B, . . .), which are more or less different from A, and which sooner or later acquire generative organs. From their impregnated germs A is reproduced. The process thus described is what has been termed the "alternation of generations" under its simplest form,—for example, as it is exhibited by the *Salpa*. In more complicated cases, the independent organisms which correspond with B may give rise agamogenetically to others (B<sub>1</sub>), and these to others (B<sub>2</sub>), and so on (e.g., *Aphis*). But, however long the series, a final term appears which develops sexual organs, and reproduces A. The "alternation of generations" is, therefore, in strictness, an alternation of asexual with sexual generation, in which the products of the one process differ from those of the other.

The *Hydrozoa* offer a complete series of gradations between those cases in which the term B is represented by a free, self-nourishing organism (e.g., *Cyanea*), through those in which it is free but unable to feed itself (*Caly cophorida*), to those in which the sexual elements are developed in bodies which resemble free zooids, but are never detached, and are mere generative organs of the body on which they are developed (*Cordylophora*).

In the last case, the "individual" is the total product of the development of the impregnated embryo, all the parts of which remain in material continuity with one another. The multiplication of mouths and stomachs in a *Cordylophora* no more makes it an aggregation of different individuals than the multiplication of segments and legs in a centipede converts that Arthropod into a compound animal. The *Cordylophora* is a differentiation of a whole into many parts, and the use of any terminology which implies that it results from the coalescence of many parts into a whole is to be deprecated.

In *Cordylophora* the generative organs are incapable of maintaining a separate existence; but in nearly allied *Hydrozoa* the unquestionable homologues of these organs become free zooids, in many cases capable of feeding and growing, and developing the sexual elements only after they have undergone considerable changes of form. Morphologically, the swarm of *Medusae* thus set free from a Hydrozoon are as much organs of the latter, as the multitudinous pinnules of a *Comatula*, with their genital glands, are organs of the Echinoderm. Morphologically, therefore, the equivalent of the individual *Comatula* is the Hydrozoic stock + all the *Medusae* which proceed from it.

No doubt it sounds paradoxical to speak of a million of *Aphides*, for example, as parts of one morphological individual; but beyond the momentary shock of the paradox no harm is done. On the other hand, if the asexual *Aphides* are held to be individuals, it follows, as a logical consequence, not only that all the polypes on a *Cordylophora* tree are "feeding individuals," and all the genital sacs "generative individuals," while the stem must be a "stump individual," but that the eyes and legs of a lobster are "ocular" and "locomotive individuals." And this conception is not only somewhat more paradoxical than the other, but suggests a conception of the origin of the complexity of animal structure which is wholly inconsistent with fact.

#### IV. ÆTIOLOGY.

Morphology, Distribution, and Physiology investigate and determine the facts of Biology. Ætiology has for its object the ascertainment of the causes of these facts, and the explanation of biological phenomena, by showing that they constitute particular cases of general physical laws. It is hardly needful to say that ætiology, as thus conceived, is in its infancy, and that the seething controversies, to which the attempt to found this branch of science made in the *Origin of Species* has given rise, cannot be dealt with in the limits of this article. At most, the general nature of the problems to be evolved, and the course of inquiry needful for their solution, may be indicated.

In any investigation into the causes of the phenomena of life, the first question which arises is, whether we have any knowledge, and if so, what knowledge, of the origin of living matter?

In the case of all conspicuous and easily-studied organisms, it has been obvious, since the study of nature began, that living beings arise by generation from living beings of a like kind; but before the latter part of the 17th century, learned and unlearned alike shared the conviction that this rule was not of universal application, and that multitudes of the smaller and more obscure organisms were

produced by the fermentation of not-living, and especially of putrefying dead matter, by what was then termed *generatio aquivoca* or *spontanea*, and is now called *abiogenesis*. Redi showed that the general belief was erroneous in a multitude of instances; Spallanzani added largely to the list; while the investigations of the scientific helminthologists of the present century have eliminated a further category of cases in which it was possible to doubt the applicability of the rule "*omnis vivum e vivo*" to the more complex organisms which constitute the present fauna and flora of the earth. Even the most extravagant supporters of abiogenesis at the present day do not pretend that organisms of higher rank than the lowest *Fungi* and *Protozoa* are produced otherwise than by generation from pre-existing organisms. But it is pretended that *Bacteria*, *Torula*, certain *Fungi*, and "Monads" are developed under conditions which render it impossible that these organisms should have proceeded directly from living matter.

The experimental evidence adduced in favour of this proposition is always of one kind, and the reasoning on which the conclusion that abiogenesis occurs is based may be stated in the following form:—

All living matter is killed by being heated to a degree.

The contents of the closed vessel A have been heated to a degree.

Therefore, all living matter which may have existed therein has been killed.

But living *Bacteria*, &c., have appeared in these contents subsequently to their being heated.

Therefore, they have been formed abiogenetically.

No objection can be taken to the logical form of this reasoning, but it is obvious that its applicability to any particular case depends entirely upon the validity, in that case, of the first and second propositions.

Suppose a fluid to be full of *Bacteria* in active motion, what evidence have we that they are killed when that fluid is heated to a degree? There is but one kind of conclusive evidence, namely, that from that time forth no living *Bacteria* make their appearance in the liquid, supposing it to be properly protected from the intrusion of fresh *Bacteria*. The only other evidence, that, for example, which may be furnished by the cessation of the motion of the *Bacteria*, and such slight changes as our microscopes permit us to observe in their optical characters, is simply presumptive evidence of death, and no more conclusive than the stillness and paleness of a man in a swoon are proof that he is dead. And the caution is the more necessary in the case of *Bacteria*, since many of them naturally pass a considerable part of their existence in a condition in which they show no marks of life whatever save growth and multiplication.

If indeed it could be proved that, in cases which are not open to doubt, living matter is always and invariably killed at precisely the same temperature, there might be some ground for the assumption, that, in those which are obscure, death must take place under the same circumstances. But what are the facts? It has been pointed out at the commencement of this article, that the range of high temperatures between the lowest, at which some living things are certainly killed, and the highest, at which others certainly live, is rather more than 100° Fahr., that is to say, between 104° Fahr. and 208° Fahr. It makes no sort of difference to the argument how living beings have come to be able to bear such a temperature as the last mentioned; the fact that they do so is sufficient to prove that, under certain conditions, such a temperature is not sufficient to destroy life.

Thus it appears that there is no ground for the assumption that all living matter is killed at some given temperature between 104° and 208° Fahr.



But, further, there is very strong reason for believing that the influence of temperature on life is greatly modified, first, by the nature of the medium in which organisms are placed, and, secondly, by the length of time during which any given temperature is kept up.

On this point recent experiments made by Dr Roberts of Manchester are of great importance. He found, for example, as every other careful experimenter has done, that ordinary infusion of hay boiled for a few minutes was sterilized, that is to say, no development of *Bacteria* took place in it, however long it might be kept; while if the infusion was rendered alkaline with ammonia or liquor potassæ, it was not sterilized except after an exposure to the heat of boiling water for more than an hour. Sometimes it became productive after two hours, and once after three hours of such exposure. Is it to be imagined that, in the case of the alkalinized hay infusion, the heat applied really killed the *Bacteria* which existed in the infusion, and that *Bacteria* of identically the same kind were generated afresh out of the dead matter! or is it more probable that the powers of resistance of the *Bacteria* to heat were simply increased by the alkalinity of the infusion! The statement of the questions surely render it unnecessary to answer them.

Dr Roberts further proves that there are two factors in the induction of sterilization, the degree of heat on the one hand, and the duration of its application on the other. A longer exposure to a lower temperature was equivalent to a shorter exposure to a higher temperature. "For example, speaking roughly, an exposure of an hour and a half to a heat of 212° Fahr. appeared to be equivalent to an exposure for fifteen minutes to a heat of 228° Fahr."<sup>1</sup>

It is hard to conceive what explanation can be offered of this fact, except that, under the conditions of the experiment, the organisms were either all affected by the first incidence of the heat in such a way as only to arrest some of their vital functions, and to leave a potentiality of life in them, such as exists in some kinds of dried living matter; or that they individually differed very much in their powers of resistance, and that some were able to withstand heat much longer than others.

Under these circumstances it will be evident, that no experimental evidence that a liquid may be heated to a degree, and yet subsequently give rise to living organisms, is of the smallest value as proof that abiogenesis has taken place, and for two reasons:—Firstly, there is no proof that organisms of the kind in question are dead, except their permanent incapacity to grow and reproduce their kind; and secondly, since we know that conditions may largely modify the power of resistance of such organisms to heat, it is far more probable that such conditions existed in the experiment in question, than that the organisms were generated afresh out of dead matter.

Not only is the kind of evidence adduced in favour of abiogenesis logically insufficient to furnish proof of its occurrence, but it may be stated as a well-based induction, that the more careful the investigator, and the more complete his mastery over the endless practical difficulties which surround experimentation on this subject, the more certain are his experiments to give a negative result; while positive results are no less sure to crown the efforts of the clumsy and the careless.

It is argued that a belief in abiogenesis is a necessary corollary from the doctrine of Evolution. This may be true of the occurrence of abiogenesis at some time; but if the present day, or any recorded epoch of geological time, be in question, the exact contrary holds good. If all living beings have been evolved from pre-existing forms of life, it is

enough that a single particle of living protoplasm should once have appeared on the globe, as the result of no matter what agency. In the eyes of a consistent evolutionist any further independent formation of protoplasm would be sheer waste.

The production of living matter since the time of its first appearance, only by way of biogenesis, implies that the specific forms of the lower kinds of life have undergone but little change in the course of geological time, and this is said to be inconsistent with the doctrine of evolution. But, in the first place, the fact is not inconsistent with the doctrine of evolution properly understood, that doctrine being perfectly consistent with either the progression, the retrogression, or the stationary condition of any particular species for indefinite periods of time; and secondly, if it were, it would be so much the worse for the doctrine of evolution, inasmuch as it is unquestionably true, that certain, even highly organized, forms of life have persisted without any sensible change for very long periods. The *Terebratula psittacea* of the present day, for example, is not distinguishable from that of the Cretaceous epoch, while the highly organised Teleostean fish, *Beryx*, of the Chalk differed only in minute specific characters from that which now lives. Is it seriously suggested that the existing *Terebratula* and *Beryces* are not the lineal descendants of their Cretaceous ancestors, but that their modern representatives have been independently developed from primordial germs in the interval! But if this is too fantastic a suggestion for grave consideration, why are we to believe that the *Globigerina* of the present day are not lineally descended from the Cretaceous forms! And if their unchanged generations have succeeded one another for all the enormous time represented by the deposition of the Chalk and that of the Tertiary and Quaternary deposits, what difficulty is there in supposing that they may not have persisted unchanged for a greatly longer period!

The fact is, that at the present moment there is not a shadow of trustworthy direct evidence that abiogenesis does take place, or has taken place, within the period during which the existence of life on the globe is recorded. But it need hardly be pointed out, that the fact does not in the slightest degree interfere with any conclusion that may be arrived at deductively from other considerations, that, at some time or other, abiogenesis must have taken place.

If the hypothesis of evolution is true, living matter must have arisen from not-living matter; for by the hypothesis, the condition of the globe was at one time such that living matter could not have existed in it,<sup>2</sup> life being entirely incompatible with the gaseous state. But living matter once originated, there is no necessity for another origination, since the hypothesis postulates the unlimited, though perhaps not indefinite, modifiability of such matter.

Of the causes which have led to the origination of living matter, then, it may be said that we know absolutely nothing. But postulating the existence of living matter endowed with that power of hereditary transmission, and with that tendency to vary which is found in all such matter, Mr Darwin has shown good reasons for believing that the interaction between living matter and surrounding conditions, which results in the survival of the fittest, is sufficient to account for the gradual evolution of plants and animals from their simplest to their most complicated forms, and for the known phenomena of Morphology, Physiology, and Distribution.

<sup>2</sup> It makes no difference if we adopt Sir W. Thomson's hypothesis, and suppose that the germs of living things have been transported to our globe from some other, seeing that there is as much reason for supposing that all stellar and planetary components of the universe are or have been gaseous, as that the earth has passed through this stage.

<sup>1</sup> *Proceedings of the Royal Society*, No. 152, p. 290.

Mr Darwin has further endeavoured to give a physical explanation of hereditary transmission by his hypothesis of Pangenesis; while he seeks for the principal, if not the only, cause of variation in the influence of changing conditions.

It is on this point that the chief divergence exists among those who accept the doctrine of Evolution in its general outlines. Three views may be taken of the causes of variation:—

a. In virtue of its molecular structure, the organism may tend to vary. This variability may either be indefinite, or may be limited to certain directions by intrinsic conditions. In the former case, the result of the struggle for existence would be the survival of the fittest among an indefinite number of varieties; in the latter case, it would be the survival of the fittest among a certain set of varieties, the nature and number of which would be predetermined by the molecular structure of the organism.

b. The organism may have no intrinsic tendency to vary, but variation may be brought about by the influence of conditions external to it. And in this case also, the variability induced may be either indefinite or defined by intrinsic limitation.

c. The two former cases may be combined, and variation may to some extent depend upon intrinsic, and to some extent upon extrinsic, conditions.

At present it can hardly be said that such evidence as would justify the positive adoption of any one of these views exists.

If all living beings have come into existence by the gradual modification, through a long series of generations, of a primordial living matter, the phenomena of embryonic development ought to be explicable as particular cases of the general law of hereditary transmission. On this view, a tadpole is first a fish, and then a tailed amphibian, provided with both gills and lungs, before it becomes a frog, because the frog was the last term in a series of modifications whereby some ancient fish became an urodele amphibian; and the urodele amphibian became an anurous amphibian. In fact, the development of the embryo is a recapitulation of the ancestral history of the species.

If this be so, it follows that the development of any organism should furnish the key to its ancestral history; and the attempt to decipher the full pedigree of organisms from so much of the family history as is recorded in their development has given rise to a special branch of biological speculation, termed *phylogeny*.

In practice, however, the reconstruction of the pedigree of a group from the developmental history of its existing members is fraught with difficulties. It is highly probable that the series of developmental stages of the individual organism never presents more than an abbreviated and condensed summary of ancestral conditions; while this summary is often strangely modified by variation and adaptation to conditions; and it must be confessed that, in most cases, we can do little better than guess what is genuine recapitulation of ancestral forms, and what is the effect of comparatively late adaptation.

The only perfectly safe foundation for the doctrine of Evolution lies in the historical, or rather archaeological, evidence that particular organisms have arisen by the gradual modification of their predecessors, which is furnished by fossil remains. That evidence is daily increasing in amount and in weight; and it is to be hoped that the comparison of the actual pedigree of these organisms with the phenomena of their development may furnish some criterion by which the validity of phylogenetic conclusions, deduced from the facts of embryology alone, may be satisfactorily tested.

*Bibliography.*—Haeckel, *Generelle Morphologie*; H. Spencer, *Principles of Biology*. (T. H. H.)

#### LIMITS AND CLASSIFICATION OF THE VEGETABLE KINGDOM.

The fundamental difference which separates the *vegetable kingdom* from the *animal kingdom* is to be found in the modes of nutrition which obtain in each. If we compare a plant and animal reduced to their simplest terms, and consisting, therefore, in each case of a single cell, i.e., of a minute mass of protoplasm invested with a cell-wall, while the unicellular plant draws its nutriment by simple imbibition through the cell-wall from the surrounding medium—a process which implies that all its nutriment passes into it in a liquid form—the unicellular animal is able to take in solid nutriment by means of interruptions in the continuity of the cell-wall, and is also able afterwards to reduce this solid food, if of a suitable composition, to the liquid state. And not merely is there a difference of this kind in the mode, there is also one no less important, although less general, in the materials of nutrition. While under present terrestrial conditions those substances, or chemical combinations, which are required for the nutrition of animal organisms, are, as far as we know, nowhere spontaneously produced—that is to say, nowhere apart from the influence of living organisms—materials derived wholly from the inorganic world are sufficient to sustain directly nearly the whole of vegetable life, and therefore, indirectly, of all other life as well. Roughly speaking, while plants are able to use for the purposes of nutrition binary compounds, such as carbon dioxide (CO<sub>2</sub>), water (H<sub>2</sub>O), and ammonia (NH<sub>3</sub>), animals are essentially dependent on the same elements as enter into these compounds, but mostly in a higher state of chemical aggregation than the binary. Plants, therefore, are the “hewers of wood and drawers of water” for other living things. And this property which they so largely possess of constructing, from materials not directly available for animal nutrition, substances which are so, is found to be uniformly attended with the presence of a peculiar green colouring matter, known as chlorophyll, with which a portion of the protoplasm of their cells is tinged. Many plants, however, such as the whole group of *Fungi*, as well as some flowering plants, draw their nutriment from compounds derived from other organisms, and therefore in a higher state of chemical aggregation than those the green plants make use of. So far they approach animals in the mode of their nutrition.

At first sight it might seem a probable hypothesis that the part played by green plants is one which has always been filled by them from the earliest appearance of life upon the earth. It must, however, be noticed that the presence of chlorophyll in the organism depends upon a specialization of some only of its constituent cells, and of part only of the protoplasmic contents of those cells. The inference, which appears to be justified by general biological principles, is that such a specialization is not a thing of primary origin, but has been gradually attained. We are thus, therefore, led to the supposition that the very earliest plants—probably belonging to the same stock as the very oldest animals—were destitute of chlorophyll, and were nourished, as *Fungi* are now, by the imbibition of substances fitted for their nutrition, but which, in the conditions that accompanied the first appearance of life upon the earth's surface, were produced independently of any organisms. The development of chlorophyll would, therefore, on this view, have to be regarded as a later acquirement.

It is necessary to bear some considerations of this kind in mind in order to clearly apprehend the relation to one another of the different phases of nutrition which the vegetable kingdom includes. The plants, for example, which

we collectively term *Fungi* may, and probably do, include descendants of the original stock which existed before plants possessed chlorophyll at all. No doubt also *Fungi* comprise plants which are destitute of the chlorophyll possessed by their near allies, in consequence of the degeneration due to a parasitic mode of life. Amongst Flowering Plants we cannot doubt that this has been the case with *Oscutia*, *Orchidaceae*, *Lathræa*, and many others. But besides plants which are actually parasitic, there are other degraded allies of green plants, which are content to work up again the imperfectly broken down products of decay. Such plants are termed *Saprophytes*; many examples of them exist amongst the *Orchidaceae*, such as *Neottia*, *Epipogium*, and *Coralorrhæa*. They live upon the products of the decomposition of vegetable matter, and have more or less completely lost the characteristic green tint of chlorophyll, which would be useless to them if they possessed it. But perhaps the most curious case of the occasional disposition of even green plants to seize upon nutritive matter in an available state of chemical aggregation, is that which is met with in the numerous examples now known of insectivorous plants.

In these latter cases we certainly find morphological adaptation of considerable complexity for purposes of nutrition. But in the vegetable kingdom generally this is certainly the exception rather than the rule. In the animal kingdom it is very different. Amongst plants, however, adaptations of structure which have reference to reproduction assume far greater importance, and these have to a large extent to be relied upon for taxonomic purposes.

Even in the highest plants the physiological division of labour is very small compared with the extent to which it exists amongst animals. From plants of the simplest structure up to the most complicated, the plan of nutrition retains the same broad features. There are few physiological facts of real importance to be observed in the highest terms of the series which may not be equally well studied in the lower.

Amongst such of the lower plants as are aquatic in their mode of life the protoplasm of individual cells is often broken up into fragments, very minute in size, which are set free in the surrounding fluid, and being furnished with *cilia* or motile filamentous prolongations of their protoplasm, rapidly disperse themselves over a considerable area. Such locomotive organisms are usually called *zoospores*. After a time each is invested with a cell-wall composed of *cellulose*; this differs entirely in composition from protoplasm, especially in containing no nitrogen. The production of the cell-wall is not therefore to be regarded as a modification of any part of the protoplasm, but as a segregation of particles of cellulose which were intermixed with it; such a segregation goes on repeatedly, wherever life exists in plant tissues. *Starch*, which is identical in ultimate composition with cellulose, we know to be fabricated from inorganic materials in the chlorophyll-granules (which are specialized portions of protoplasm) under the influence of light. Cellulose is derived from the starch so manufactured, and is dispersed in a state probably of molecular subdivision throughout the protoplasm.

The cellulose wall is not apparently essential to the conception of a vegetable cell, but it is, perhaps, not going too far to say that its existence has conditioned almost all the histological and morphological peculiarities of plant construction. The cell, as already pointed out, although bounded with what is relatively a tough and even rigid cell-wall, is by no means debarred from further nutrition and growth. If destitute of chlorophyll, it may take in nutrient matter, which only requires some moderate elaboration to suit it for incorporation with the protoplasm. If,

on the other hand, chlorophyll be present, it will do a good deal of preliminary work in preparing the substances which then, as before, the protoplasm will further appropriate and work upon. In either case the protoplasm of the cell will grow, and as the processes which have been described are generally accompanied by the imbibition of fluid, the cell-wall is subjected in consequence to a considerable tension. The cell-wall, under these circumstances, grows also, and the experiments of Traube seem to show that, given the conditions under which it is known to take place, this growth is almost entirely a physical process. Carried beyond a certain point, tension must result in rupture; but just short of this there appears to be a limit at which the intercalation of new molecules of cellulose is permitted, and so the surface of the cell-wall is enlarged. In *Edogonium* there is a peculiar arrangement in which fracture actually does take place repeatedly. A circular cleft is formed, which is repaired within by the apposition of an annular splice.

To the growth of a cell so conceived there would seem to be no limit, and in the *Siphophyceae*, of which *Vaucheria* is a well-known type, there is apparently none. The vegetative portion of these organisms, however complicated, is always formed by the extension of a single cell; the protoplasm is continuous throughout every part, and except when zoospores are formed is never segmented.

This, however, is a rare arrangement. Generally speaking, there comes a time when the protoplasm, by a phase of contractility, divides itself into two masses, and between these a partition of cellulose is formed in the same way as the coat of the naked zoospores already alluded to. Each cell so formed possesses all the capacity for nutrition and growth which the whole possessed. It divides therefore in its turn, and in this way we get the first indication of an aggregate of cells. In the lower plants the cell is complete in itself; in the higher, its independence is more or less merged in that of the others with which it is associated.

This aggregation seems to begin in a purely mechanical way. In *Pleurococcus*, for example, cell division repeated a few times may produce aggregation of, at any rate, four cells. If it were not that the adhesion of these cells seems afterwards to fail, there would be no reason why the mere process of cell division should not produce larger aggregates. But the cell-wall common to two adjacent cells splits through its middle lamina, and the two neighbouring cells part company. In *Hydrodictyon* we have a remarkable example of the formation of an aggregate synthetically, owing to the action of some cause which is quite imperfectly understood, but which is probably purely physical. An enormous number of zoospores are formed from the contents of a parent cell, and these, after tumultuously moving within its cavity, come to rest, and at the same time arrange themselves in the well-known net-like fashion which is characteristic of the full-grown plant. The mechanical persistence of aggregates of cells formed by normal cell division is obviously the step which led to the evolution of such organisms as *Volvox* and *Ulvæ*, since these are merely aggregates of simple types, such as *Chlamydococcus* and *Pleurococcus*.

At first the independence of the individual aggregated cells would be little impaired. In a *Spirogyra* or *Oscillatoria*, for example, the number of cells present in a filament is probably a matter which does not affect the cells themselves individually, and which conversely they have no power of influencing. The constituent cells might go on dividing, and so form filaments of unlimited length, but which occasionally would be liable to be broken up by arbitrary accident. In *Cladophora*, however, the cells of a filament cease after a time to divide transversely, and

branch by the production of lateral swellings, which are elongated and then divided off by cellulose partitions. It seems reasonable to suppose that branching in this case simply means that one part of the cell-wall is weaker, less fitted to withstand internal tension, than the rest. If the cell-wall were uniform it would stretch uniformly, and the want of uniformity in the cell-wall may probably be traced to its being part of an aggregate. The string of cells is moored by one end, and any motion of the water will cause it to assume an oblique position. It is then unequally influenced by gravity and by light, and these two forces are known to be competent to modify growth in an unsymmetrical manner under such circumstances.

Reasoning of this kind will at any rate suggest the way in which the specialization of individual cells would be a result of their aggregation. With this specialization they would lose an increasing amount of their capacity for independent existence. Specialization of function will, of course, be reflected in corresponding morphological modifications, and thus a mechanical aggregate of independent cell elements gradually passes into a physiological aggregate of interdependent ones.

One obvious penalty of specialization is the loss of the power of reproduction by individual cells when detached. Amongst plants, however, even the highest types preserve some measure of it. It is sufficient to adduce the common horticultural method of propagating *Begonias* from fragments of the leaves. Such a mode of reproduction in one of the highest plants is essentially the same as that which exists in *Pleurococcus*, and although reproduction from fragments of structures so specialized as a leaf is comparatively rare, there are in almost all plants provisions for agamogenesis, which depend upon the retention by fragments of the organism of this capacity for independent existence. And it may even happen that the perpetuation of the race for considerable periods may come to depend upon such a property. One of the most striking instances of this is the distribution over the British Isles of the American water-weed (*Anacharis*), of which, nevertheless, only the female plant exists in this country. If we had the male, we should have a good instance (and others might be given) of gamogenesis and agamogenesis proceeding side by side in individuals of the same generation, although probably not without the two processes reacting upon one another. Throughout the vegetable kingdom, however, we find gamogenesis and agamogenesis occurring in separate generations, which are often extremely different. The two modes of reproduction are then subject to a cyclical arrangement, and the comparison of the forms under which this alternation of generations occurs in different groups throws a good deal of light upon their taxonomic relations. It will be convenient to use the word "*Sporophore*" for the agamogenetic generation, in which special cells (*spores*) are detached from the parent to serve as a means of propagation; while for the gamogenetic generation, in which conjugation takes place, or in which special cells (*oospheres*) are fertilized by antherozoids, and become *oospores*, "*Oophore*" may be employed.

Our present knowledge has rather added to than diminished the difficulty of devising even a plausible phylogenetic classification of the vegetable kingdom. Greater success has, however, been attained in establishing the primary and larger secondary groups, so as to allow us to feel some confidence that they are really natural assemblages. The relation of these groups to one another is a problem, the more than approximate solution of which will probably have to be some time postponed. Many of them appear to represent the later developments of simpler types or aggregates than anything that these groups at present contain. The *Syngonanthaceae*, for example, are extremely ancient, yet

we know of no form, living or extinct, which enables us to trace the connection of their very remarkable organization with that of other groups. In the animal kingdom the "recapitulation theory" steps in, and obtains from the study of the development of the organism that kind of information which is wanting amongst plants as to the simpler ancestral forms of the different vegetable types. This information, however, is drawn in the animal kingdom to a large extent from the phenomena presented by the differentiation of the sustentative organs of the embryo. For reasons already pointed out, there is nothing analogous to this amongst plants, where the rapid extension of surface is usually the primary object to be attained. The earliest stages in the development of any plant are subject to conditions so simple that there is little room for specialization, and the economy of nutrition has probably generally led to the suppression of recapitulative structural details.

On the other hand, if we derive little help from recapitulation in studying the process of development in plants, from the unicellular stage of spore or oospore, it proves extremely suggestive, if we take in the whole cycle comprised between two processes of gamogenesis, and compare the relations to one another of the gamogenetic and agamogenetic generations, or using the nomenclature introduced above, of the *Oophore* and *Sporophore*.

#### THALLOPHYTES.

Endlicher, in 1836, divided the vegetable kingdom into *Thallophyta* and *Cormophyta*; and these divisions still hold good, though it is by no means easy to frame characters which will strictly limit them. With the exception of the absence in the one, and presence in the other, of the "opposition of stem and root," none of the distinctions which Endlicher pointed out are available now. Throughout the greater part of the *Thallophyta* anything like a distinct segmentation of an axis furnished with lateral appendages is altogether wanting. As thus limited by the absence of a clear differentiation of root, stem, and lateral appendages, this sub-kingdom comprises an assemblage of plants, which were divided by Bishop Agardh, in 1821, into the three well-known groups of *Algae*, *Fungi*, and *Lichens*. And to these, for reasons which will be presently pointed out, must be added the hitherto problematical group of *Characeae*.

It has long been seen that, with respect to the three former groups, it was impossible to assign morphological characters which would separate them strictly one from the other. Accordingly, Berkeley and Lindley were compelled to fall back on distinctions of a physiological kind. *Algae* were defined to be generally *aquatic* in their mode of life; *Fungi* and *Lichens*, on the other hand, were *aerial*,—but the former drew their nutriment from the "substratum," while the latter obtained it from the air.

There are several grounds on which this arrangement appears to need reconsideration.

Contrasting, in the first place, *Algae* and *Fungi*, we now know that the plants belonging to the former group invariably contain chlorophyll, while those belonging to the latter are equally devoid of it. In their morphological aspects, however, the two groups present a remarkable parallelism.

Now, the importance of the presence or absence of chlorophyll, and the difference in the mode of life which results, would have greater weight for classificatory purposes, were we not familiar with instances in other parts of the vegetable kingdom in which it proves to have no value at all. Amongst flowering plants we are acquainted with many cases where plants closely allied in structure to

others in which chlorophyll is normally developed, are entirely destitute of it. These considerations have recently led Cohn and Sachs to treat *Fungi* and *Alga* as an assemblage of organisms the classification of which is to be attempted on purely morphological grounds. But the assemblage of plants formed by *Alga* and *Fungi* which thus appear to require classification anew, has been further increased by the addition of two other groups, both regarded quite recently as entirely distinct. In 1868 Schwendener proposed his now well-known theory as to the true nature of Lichens; and although his views have been vigorously attacked, chiefly by writers who seemed to feel that they had a vested interest in their autonomy, the weight of testimony, in the case of those who have examined the matter in a wider spirit, has been to strongly confirm Schwendener's hypothesis. Lichens must now be regarded as composite structures, partly consisting of an alga, partly of a fungus. Quite lately Sachs has pointed out (in the 4th edition of his *Lehrbuch der Botanik*) that *Characeae* may be compared with the structure and mode of reproduction of some of the *Florideae*.

Sachs has proposed a classification of the *Thallophyta*, which appears to be the best that our present knowledge admits of. He divides them into four classes—*Protophyta*, *Zygosporae*, *Oosporeae*, and *Carposporeae*.

1. The *Protophyta* include the simplest plants, and those in which at present gamogenesis is not known to occur. In the *Cyanophyceae* the protoplasm of the cells is destitute of a nucleus, and, besides containing chlorophyll, is tinged with a peculiar bluish colouring matter, known by the name of phycocyan. In *Palmellaceae* this peculiar pigment is absent. *Euglenae* is a group of well-known but little understood organisms, which must also be placed here provisionally. To these must be added *Schizomycetes* (Bacteria), which are the agents of putrefactive changes in nitrogenous organic matters, and *Saccharomyces* (yeast), which bring about the phenomena known as "fermentation." The *Schizomycetes* appear to be allied in some respects to *Chroococcaceae* and *Oscillatoriaceae* amongst the *Cyanophyceae*. The true position of *Saccharomyces* for the present be held as problematical; we are still without evidence to conclusively decide in favour either of its autonomy or of its being a peculiar condition of a member of some group of *Fungi* of more complex development.

2. The *Zygosporae* are an assemblage of organisms, none of the members of which attain any high degree of morphological complexity, and in all the subordinate divisions of which the simplest form of gamogenesis, known as *conjugation*, has been observed to take place. Conjugation only differs from the normal process of fertilization in the two protoplasmic bodies which take part in it being precisely similar in bulk and form. Till Thwaites pointed out the contrary in 1848, it was not supposed to be entitled to recognition as a sexual process. But fertilization, as ordinarily understood, only differs in the two conjugating bodies being unlike—that is, in their having undergone differentiation into *antherozoid* and *Oosphere*, the male and female bodies respectively.

The *Zygosporae* may be divided, perhaps artificially, into two groups, according as the conjugating cells are motile or non-motile.

In many of the simpler green *Alga* it has long been known that two kinds of zoospores, differing in size, are produced. To these the terms macrozoospore and microzoospore may be applied. The function of the macrozoospores is purely agamogenetic. The microzoospores, on the other hand, meet in pairs, and fuse into a single protoplasmic body, which Areschoug has termed a *zygozoospore*.

The process was first observed by Pringsheim in *Par-*

*dotina*. It has also been observed in *Chlamydomonas*. On these grounds Sachs has placed the whole group of the *Volvocinaceae* amongst the *Zygosporae*. This has, however, been reasonably objected to by Cohn, inasmuch as in *Eudotina* as described by Carter, and in *Volvox* as observed by himself, there is a true process of fertilization by means of antherozoids, and not a simple conjugation. It may be allowed, therefore, provisionally to break up the *Volvocinaceae*, or rather to restrict the name to the two last-named genera, which may then be removed to the next class, using that of *Pandorinaceae* for *Volvocinaceae* forms, which only exhibit conjugation. *Hydrodictyces* should probably be placed here, and also *Confervaceae* and *Ulvaceae* in which the conjugation of zoospores has been observed by Areschoug.

Sachs has proposed to associate with the *Zygosporae* the *Myxomycetes*, in which the formation of the plasmodium is a kind of complex conjugation. Closely allied in some respects to the *Myxomycetes* are *Chytridinae* and, more doubtfully, *Protomyces*.

In the second division, in which the conjugating cells are non-motile, must be placed all the more familiar instances of the process—the *Desmidiaceae*, the *Diatomaceae*, the *Zygnemaceae*, and the *Zygomycetes* as a fungoid type.

3. The *Oosporeae* must include the *Volvocinaceae*, in the limited sense already explained, and also *Sphaeroplea*—a form divorced on much the same grounds from *Confervaceae*. *Fucus* affords the best known type of reproduction belonging to this group. The antherozoids are ciliate bodies discharged from *antheridia*; the *oospheres* are naked protoplasmic masses originally contained in *ogonia*. The antherozoids gather round them in such numbers as to impart to them a movement of rotation. They eventually completely blend with the oosphere, which becomes surrounded with a coat, and sinks to the bottom of the fluid in which it has hitherto been suspended. It is now an oospore, and speedily undergoes a process of cell division, which gives rise to an individual of the new generation. Near the *Fucaeae* a place must probably be assigned to the *Phaeosporae*. The remaining groups which fall into *Oosporeae* are *Coloblastae* and *Edogoniacae*. *Coloblastae* have their protoplasm unsegmented throughout the vegetative portions of the organism. They include forms which are partly algal, such as *Vaucheria* and the *Siphophyceae* generally, partly fungoid, as *Peronosporae* and *Saprolegniae*. In all other respects, except the presence or absence of chlorophyll, they closely agree with one another, and the consideration of this fact has led, perhaps more than any other fact, to the breaking down of the barrier between *Algae* and *Fungi*.

4. The *Carposporeae*<sup>1</sup> agree with the *Oosporeae* in so far that the two sexual organs contribute in very different proportions to the formation of the sexual product. While the male only stimulates its development, the female supplies the material for the whole subsequent growth.

The female organ, or *carpogonium*, may consist of one or more cells. The male organ varies very considerably in the different subordinate groups. Fertilization may, as in the *Oosporeae*, be effected by antherozoids (which may be actively motile or passively locomotive), or by a kind of conjugation, or even by a mere apposition of the male organ and subsequent diffusion of the fertilizing medium. The product of the act of fertilization is sometimes a single cell developing directly into a new individual (*Chara*). In other cases the fertilized female organ produces zoospores, and still more commonly a multicellular mass in which spores are finally developed. This involves an alternation of the generations of the type of that met with in the sporocarp of *Muscicinea*.

<sup>1</sup> See Sachs's *Lehrbuch*, 4th ed. pp. 240-243.

And we may have every grade of development, from the simplest case, in which the sporocarp appears as a mere appendage of the parent plant of inconsiderable dimensions, to the most extreme condition in the other direction, in which the sporocarp is capable of independent growth, and therefore represents a second generation which is entirely distinct (*sporophore*). The sporocarp also differs essentially from the oospore in the fact that cells contribute to its formation which have not been directly influenced by fertilization, and that in consequence the part of the fruit which produces the spores is surrounded by what—for want of a more convenient term—we may call the pericarp, in which no spores are developed, and which serves as a mere protective investment, or is subsequently drawn upon for purposes of nutrition. In *Phycomyces*, which belongs to *Zygosporae*, it is noteworthy that there is a kind of anticipation of the development of a protective investment to the zygospora.

The principal types of the *Carposporeae* include all the more highly developed forms both of Algae and Fungi.

In *Colochoatea* the carpoogonium terminates in an open canal, and fertilization is effected by motile antherozoids.

In *Floridex*, in the simplest type (*Nematium*), the carpoogonium resembles that of *Colochoatea*, only the terminal tube (trichogyne) is closed and not open. Fertilization is effected by passively motile antherozoids, which adhere to the trichogyne. In *Ceramiea* the carpoogonium, even before fertilization, consists of numerous cells, a lateral row of which—the trichophore—bears the trichogyne. Neither trichogyne nor trichophore, however, take any part in the development of the sporocarp. The pericarp is produced by a process of budding from cells beneath the carpoogonium.

In the genus *Dudresnaya* the process of fertilization becomes very complicated, and in fact involves a double process, of which the first stage consists in the application of antherozoids to a trichogyne; and the second in the development from below the trichophore of a “conducting filament” which conveys the fertilizing influence to the terminal cells of a number of small branches, with which it successively conjugates; at each point of conjugation a sporocarp is developed. Amongst the *Ceramieae* there is something comparable to this double process; the fertilizing influence which is conveyed by antherozoids to the trichogyne must afterwards be communicated by a process of diffusion from the trichophore to the cell from which the spores are developed.

*Characeae* are now to be regarded as a reduced type of *Carposporeae*. The carpoogonium is supported by two basal cells with oblique septa, which it seems quite reasonable to accept as the rudiments of a trichophore. There is, of course, no trichogyne, and fertilization is effected by motile antherozoids, and the pericarp is developed before instead of after this process. In *Chara* the main axis is clothed with a peculiar cortical tissue, which grows over it from the nodes, and is clearly comparable with that which exists in the *Ceramieae*.

Fungi contribute to the *Carposporeae* the *Ascomycetes*, *Ascidomyceles*, and *Basidiomyceles*. In the first and last of these groups the existence of a sexual process preceding the development of the sporocarp is now known. *Ascobolus* has been studied by Janczewski, and the essential features of the sexual process are closely comparable to those of *Ceramieae*. The carpoogonium consists of a row of cells; the terminal one is fertilized by the ramified “pollinodium,” and from the central cell of the carpoogonium a number of filaments branch out which bear the asci, while the pericarp is formed by the branching of the mycelium below the carpoogonium.

*Lichenes*, in so far as the hypnæ and fructification are concerned, are essentially ascomycetous fungi. Their

gonidia are referable to different groups of algae. The two sets of organisms live together in a kind of modified commensality. The algae are able to sustain their companion fungus without succumbing to the demands of its nutrition.

#### CORMOPHYTA.

Alternation of generations exists amongst the *Thallophyta*. But, as in *Ecdogonium*, it assumes the form of an occasional occurrence of gamogenesis after more or less prolonged periods of agamogenesis; a series of sporophores is interrupted by the intercalation of an oophore. Amongst the *Cormophyta*, however, we have generally a regular alternation of oophore and sporophore. Both may, however, propagate themselves by the detachment of more or less specialized gemmæ. But apart from this, the agamogenetic production of spores and the gamogenetic production of oospores regularly follow one another.

Cohn, in a classification of Cryptogams published in 1872, established the groups *Bryophyta* and *Pteridophyta*, which, added to *Phanerogamae*, constitute the groups into which *Cormophyta* appear best susceptible of division.

1. *Bryophyta*.—In such a case as *Ecdogonium*, sporophore and oophore each attain a tolerably equal degree of vegetative development. In others, however, this may be very much curtailed in one or the other generation. Amongst the *Thallophyta* the sporophore not uncommonly suffers this reduction. Thus in *Mucor* the zygospora only develops a short filament, which terminates in a sporangium filled with spores. If we suppose the filament suppressed, the spores belonging to the second generation will be produced directly from the oospore itself. Thus, amongst the *Coloblastae*, in *Cystopus* the oospore produces zoospores, and, according to Cienkowski, this is also the case with *Volvox*. In such cases the oospore itself is the sporophore. Amongst the *Bryophyta* there is an alternation of generations which is hardly less abridged. The oophore—which in *Hepatica* is often a thalloid body, while in mosses it is a leafy plant—bears female organs (*archegonia*) and male organs (*antheridia*). The oospore, or fertilized central cell of the archegonium, gives rise to a complicated structure which produces the spores. The first division of the oospore appears to be inclined to the axis of the archegonium. The sporophore is retained in a kind of attachment to the oophore, and never attains to any vegetative development of its own. From the fact that the vegetative structure of some *Hepaticae* is thalloid and leafless (*Aneura*), while in others (*Marchantia*) leaves are present in a very reduced condition, it may be inferred that the former have lost their leaves rather than that they represent an original leafless condition. The ancestral type of the *Bryophyta* was probably more like a moss than like any of the *Hepaticae*. And it is worth while considering what claims *Chara* may have to be regarded as a transition from the *Thallophyta*, of which it is an anomalous type in its possession of distinct lateral appendages to the axis. Cohn placed it amongst the *Bryophyta*; but its removal to the *Thallophyta* probably assigned it its true position. The investment of the carpoogonium, however, cannot have more than an analogy with an archegonium. The fertilized carpoogonium (sporocarp) might perhaps be regarded as a very reduced form of that of the *Bryophyta*, producing only a single spore. It is certainly an interesting and it may be a significant point, that the spore of *Characeae* produces in germinating a filamentous chain of cells, apparently comparable to the protonema of mosses, and from this the fully developed sexual plant is produced as a lateral bud.

2. *Pteridophyta* are sharply divided from *Bryophyta* by the high vegetative development of the sporophores and

gradually increasing suppression of that of the oophore. This never, however, as in the succeeding group, completely loses its independence of the sporophore.

The whole direction of the attempts at classifying the *Pteridophyta*, which correspond to the so-called vascular *Cryptogama*, has been completely changed by Fankhauser's discovery of the long-sought reproduction of *Lycopodium*. It proves to be totally unlike that of *Selaginella*, which, from the close agreement that exists between the two types in every other respect, it might have been expected to closely resemble. On the contrary, in the formation of a monocious subterranean prothallium, it may be compared to *Ophioglossa*. Yet, as Sachs has pointed out, it is impossible to use this striking divergence for the purpose of breaking up a group of plants which in all respects is perfectly congruous. The anomaly of forms so closely allied, exhibiting two modes of gamogenesis, has now, however, found a parallel amongst the *Filicales*, in which group *Rhizocarpea* seem to find their proper place.

The *Pteridophyta* are divisible into three probably natural classes, which may be briefly defined by the following characters, in themselves, no doubt, artificial:—

i. *Filicales*.—Leaves highly developed and bearing numerous sporangia.

ii. *Equisetacea*.—Leaves rudimentary, reduced to sheaths on the barren stems, the fertile ones bearing 5–10 sporangia.

iii. *Dicotoma*.—Leaves small, simple; sporangia solitary.

The *Filicales* include, according to the arrangement proposed by Sachs, three orders. In *Stipulata* the sporangia are not trichomes, but are either wholly endogenous products as in *Ophioglossum*, or are formed from cellular protuberances, and the tissue beneath the epidermis takes part in the formation of spores (*Marattiaceae*). In *Filices* proper the sporangia are, as already mentioned, trichomes, and these are developed upon the normal fronds. In *Rhizocarpea* the sporangia are borne by metamorphosed leaves, which are united into a capsular body in a way comparable to that in which carpels bearing ovules are united into a syncarpous ovary. The germination of the spores also presents important differences in the different orders amongst the *Stipulata*. In *Ophioglossacea* it gives rise to a tuberous monocious oophore (prothallium), destitute of chlorophyll. In *Osmunda* the prothallium exhibits some tendency to become dioecious; it resembles the normal type of prothallium in ferns, but has a kind of mid-rib, and produces adventitious shoots from marginal cells. These shoots become detached, and constitute a mode of agamogenesis. Such a structure cannot fail to recall the thalloid *Hepatica*, which also possess a mode of agamogenesis by means of gemmules (e.g., *Marchantia*). In *Rhizocarpea* the dioecious condition of the oophore has been carried so far that it is indicated even in the spores themselves; the microspores are male, the macrospores female. In *Salvinia* there is a rudimentary prothallium bearing the antheridia; and a last trace of such a structure appears to exist in *Marsilea* and *Pilularia*. The macrospore also develops a prothallium, in which numerous archegonia are produced, one only of which is fertilized. The development of the prothallium is so far external to the macrospore that it effects its rupture at the apical papilla. In the *Rhizocarpea* the development of the oophore has been almost entirely compressed within the limits of the spore.

*Equisetacea* call for little remark as regards the oophore. It is dioecious, and irregularly branched, but in other respects there is a close agreement with the oophore of ferns.

The *Dicotoma* present in the morphology of the oophore

a parallel series with the *Filicales*. The *Lycopodiaceae* develop from the single form of spores which they possess a monocious subterranean prothallium like that of *Ophioglossa*. The *Ligulata* (comprising *Selaginella* and *Isoetes*) produce, like *Rhizocarpea*, microspores and macrospores. In this group the suppression of the oophore is carried still further; the microspores possess, according to Millardet, the merest rudiment of a male prothallium. The macrospores produce a female prothallium, which is an endogenous structure in even a higher degree than in the *Rhizocarpea*. The first divisions of the oosphere have not as yet been sufficiently studied. But while in Ferns proper, *Equisetacea* and *Ophioglossacea*, the first septum is more or less inclined to the axis of the archegonium, it is parallel with it in *Rhizocarpea* (a position into which a very oblique inclination would readily pass), while in *Selaginella* it is at right angles with it.

3. *Phanerogama*.—In at any rate two of the three groups of the *Pteridophyta* we see that the progressive tendency of the oophore (prothallium) is to lose its independence. In *Ophioglossa*, *Filices*, and *Equisetacea*, its growth, independent of the spore, often continues for a considerable period. In *Rhizocarpea* and *Lycopodiaceae*, where male and female spores are produced, the oophore remains attached to the spore, although protruding from it. In *Isoetes* it fills the cavity of the macrospore as a mass of tissue, and the bounding wall is only ruptured to allow the access of the antherozoids to the archegonia. In the *Phanerogama* even so small an assertion of independence as this is suppressed. The macrospore (embryo-sac) is never detached from the sporophore previous to fertilization, and the oophore, which is moderately developed in the *Gymnosperma*, but in the *Angiosperma* is reduced to the merest rudiment, always remains entirely enclosed within the macrospore.

In the *Gymnosperma* the endosperm is the homologue of the prothallium (oophore). The so-called "oocypuscula" are the archegonia, or rather the central cells of reduced archegonia (secondary embryo-sacs of Hanfrey). The neck of the archegonium is represented by the "rosetta" first described by Hofmeister. Strasburger has pointed out that a small portion of the contents of the central cells is divided off at the upper end, and this is the rudiment of the canal cell which, running the length of the neck of the archegonium in the *Bryophyta* and *Pteridophyta*, leaves a pervious track by its deliquescence for the access of the antherozoids to the central cell. Strasburger considers all the rest of the contents of the embryo-sac to be the equivalent of the oosphere. The result of fertilization is to cause a transverse partition of the lower part of the oosphere, as in *Selaginella*. From the lower cell thus constituted, by successive longitudinal and transverse partitions, the suspensors are developed, the ends of each of which bear an embryo. It is noteworthy that the development of a suspensor as an intermediate structure between the fertilized oosphere and the embryo is also met with in *Selaginella*.

It only remains to point out, as far as they are understood, the comparable structures in *Angiosperma*. Here the prothallium (oophore) has completely disappeared, unless we regard, with Sachs, the "antipodal cells" as a last rudimentary trace; their appearance is, however, inconstant. Within the embryo-sac (macrospore) "embryo-vesicles" are formed, usually two or three in number. One of these is the oosphere, and may be compared to the central cell of an evanescent archegonium, to which another of the "embryo-vesicles" performs the function of a canal cell; for while it is that which is usually in nearest proximity to the pollen tube, it only apparently transmits the fertilizing influence. In a few cases this dormant embryo-vesicle is replaced by a somewhat more highly developed arrangement—the

filamentary apparatus—the homology of which, with a canal cell, is more obvious.

The foregoing sketch indicates, in a very brief manner, the outlines of the classification of the vegetable kingdom, which has been constructed in the light of the most recent studies of the comparative structure of different types. It is sufficient to say, that a detailed consideration of the new relations in which many of the groups now stand to one another by no means diminishes, but strongly confirms, the soundness of the arrangement.

The following table gives the classification in a synoptic form:—

VEGETABILIA.	
SUB-KINGDOM A. THALLOPHYTA.	
With Chlorophyll (ALGÆ.)	Without Chlorophyll (FUNGI.)
Class 1. PROTOPHYTA.	
i. <i>Cyanophyceæ.</i> Chroococcaceæ. Oscillatorias, &c.	i. <i>Schizomycetes.</i>
ii. <i>Phaeomellales.</i> [! Euglenas.]	ii. <i>Baccharomycetes.</i>
Class 2. ZYGOSPORÆ.	
a. Conjugating cells motile.	
i. <i>Pandorinas.</i> [! Hydrodictyem.]	i. <i>Mycetozoyetes.</i>
ii. <i>Chytridaceæ.</i>	ii. <i>Chytridicæ.</i>
iii. <i>Uromonas.</i>	
β. Conjugating cells non-motile.	
iv. <i>Conjugatas.</i> Desmidiæ, &c.	[! Protomyces.]
	iii. <i>Sporomyces.</i> Mucorini, &c.
Class 3. OOSPORÆ.	
i. <i>Fulvocinæ.</i>	i. <i>Ooloblastæ.</i>
ii. <i>Sphaerolobæ.</i>	Amylistem.
iii. <i>Cauloblastæ.</i> Siphophyceæ.	Saproglenem.
iv. <i>Chloocinæ.</i>	Parosporam.
v. <i>Fucosæ.</i> [Phaeosporæ.]	

Class 4. CAROSPORÆ.	
With Chlorophyll (ALGÆ.)	Without Chlorophyll (FUNGI.)
i. <i>Coleochætas.</i>	i. <i>Acromycetes.</i> Lichenas, &c.
ii. <i>Floridas.</i> Nemalies. Ceramiem, &c.	ii. <i>Stictiomycetes.</i>
iii. <i>Charocæm.</i>	iii. <i>Basidiomycetes.</i>

### SUB-KINGDOM B. CORMOPHYTA.

#### Series I. BRYOPHYTA.

##### Class 1. Musci.

##### Class 2. Hepaticæ.

#### Series II. FERRIDOPHYTA.

##### Class 1. Filicales.

i. *Stipulata.*  
Ophioglossæ.  
Marattiacæ.

ii. *Filices.*

iii. *Rhacocarpeæ.*

##### Class 2. Equisetacæ.

##### Class 3. Dichotomæ.

i. *Lycopodiaceæ.*  
Lycopodiæ.  
Fulicæ.  
Phylloglossæ.

ii. *Liquidæ.*  
Selaginellæ.  
Isoetes.

#### Series III. PHANEROGAMÆ.

##### Class 1. Gymnospermeæ.

##### Class 2. Angiospermeæ.

i. *Monocotyledonæ.*

ii. *Dicotyledonæ.*

See *A Text-Book of Botany, Morphological and Physiological*, by Julius Sachs (2d edition), translated by A. W. Bennett, assisted by W. T. Thiselton Dyer; *Lehrbuch der Botanik*, von Dr Julius Sachs, vierte Auflage; *Quarterly Journal of Microscopical Science*, new series, vols. I-xv. (W. T. T. D.)

BION, the second of the three Greek bucolic poets, was born in the neighbourhood of Smyrna,—according to Suidas, at Phloesa on the River Mæis. The few facts known to us of his life are to be gathered from the beautiful *Ἐρωδιῶνος Βίαιος* of his friend and scholar Moschus. From his account it appears that Bion left his native country and, during the latter part of his life, resided in Sicily and cultivated the form of poetry peculiarly associated with that island. He was contemporary with Theocritus and somewhat older than Moschus. His death was due to poison, administered to him by some jealous rivals who afterwards suffered the penalty of their crime. The subjects of his verses are described by Moschus as "Love and Pan;" but though his works are included in the general class of bucolic poetry, they have little of the pastoral imagery and description characteristic of Theocritus. They breathe a more refined air of sentiment, and show traces of the overstrained reflection frequently observable in later developments of pastoral poetry. The longest and best of his extant works is the *Lament for Adonis* (*Ἐρωδιῶνος Ἀδωνιδῶς*), the prototype of many modern poems. His other pieces are short and in many cases fragmentary. Two of the Idylls (xix. and xx.) of Theocritus are frequently ascribed to him. Bion and Moschus are edited separately by Hermann (1849)

and Ziegler (1869). The best annotated editions are those of Heindorf (1810), Meineke (1856), Ahrens (1855-9), Fritsche (1870), all of which contain also the works of Theocritus. The *Ἐπιτάφιος Ἀδωνιδῶς* is edited separately by Ahrens, 1854.

BIOT, JEAN BAPTISTE, French physicist, was born at Paris, 31st April 1774. After leaving school he served for a short time in the artillery, but again resumed his studies at the École Polytechnique. He distinguished himself in mathematics, and was appointed to a professorship at Beauvais. There he carried on his researches with the greatest assiduity, and gained the acquaintance and friendship of Laplace, from whom he solicited and obtained the favour of reading the proof-sheets of the *Mécanique Céleste*. In 1800 he was recalled to Paris as professor of physics at the Collège de France. Three years later he was elected a member of the Academy of Sciences, a distinction rarely accorded to one so young as he was. In 1803 Biot, in concert with Arago, investigated the refracting properties of gases, and in the following year accompanied Gay-Lussac in his balloon ascent. He was again associated with Arago in the great undertaking of the measurement of an arc of the meridian in Spain, and at a later date (1817-18) he crossed over to Britain and mea-



sured carefully the length of the seconds' pendulum along an arc extending to the extreme north of Shetland. In 1814 he was made a chevalier of the Legion of Honour, an order of which he became a commander in 1849. He was a member of the French Academy and of the Academy of Inscriptions and Belles-Lettres, as well as of most foreign scientific societies. In 1840 he received the Rumford gold medal for his researches in polarized light. He died at an advanced age in 1862. Biot's researches extended to almost every branch of physical science; but his greatest discoveries were made in the department of optics, mainly in connection with the polarization of light. He had a thorough command of the best methods of analysis, and applied mathematics rigidly and successfully to physical phenomena. His various dissertations in the *Memoirs of the Academy* are very numerous; a selection of the more valuable was published in 1858. His systematic works—*Traité Élémentaire d'Astronomie Physique* (1805, 3d ed., 1841–57, 6 vols.), *Traité de Physique* (1816, 4 vols.), *Précis Élémentaire de Physique Expérimentale* (1817, 3d ed., 1824, 3 vols.),—are of great merit, though necessarily in some respects behind the present state of physical science.

**BIR**, or **BIRĒIK** (the former being its Arabic and the latter its Turkish name), a town of Asiatic Turkey, in the pashalik of Rakka, built on the side of a chalky range of hills that skirts the left bank of the Euphrates, about 90 miles N.E. of Aleppo, in long. 38° 6' E., and lat. 36° 48' N. It consists of about 2000 houses, surrounded by a dilapidated wall and protected by the citadel of Kalai-Beda, which, with its earthquake-shattered interior, occupies a precipitous eminence cut off from the town. Bir is situated on the main route from Aleppo to Orfa, Diarbekr, and the Persian frontier, and had formerly a considerable trade with Bagdad by means of the river. It is now a post and telegraph station. A ferry seems to have crossed the river at this spot from time immemorial, Abraham himself having made use of it, according to tradition, on his passage from Haran to Canaan. The town is identified with the ancient Birtha or Britha, where the emperor Julian rested on his march to Maogamalcha, and found quarters for his army in one extensive palace. In the English Euphrates expedition Bir was frequently visited, Fort William, one of the principal places of rendezvous, being about 2 miles further down on the other side of the river. (See view in Chesney's *Narrative of Euphrates Expedition*, 1868.)

**BÍRBHÚM**, a district of British India, within the Bardwán division, under the lieutenant-governor of Bengal, situated between 24° 23' 10" and 23° 34' 54" N. lat., and 88° 3' 54" and 87° 7' 41" E. long. It is bounded on the N. by the districts of Santál Parganá and Bhágalpur; on the E. by the districts of Murshidábád and Bardwán; on the S. by the River Ajai, separating it from the district of Bardwán; and on the W. by the districts of the Santál Parganá. The census of 1872 returned the area of the district at 1344 square miles, and the total population at 695,921 souls, residing in 2471 villages and 159,904 houses. Pressure of population per square mile, 518; per village, 282; per house, 4.3. Of the total population, 576,908, or 82.9 per cent., were Hindus; 111,795, or 16.1 per cent., Mahometans; 249 Christians; and 3440, consisting principally of aboriginal tribes, of unspecified religions. The eastern portion of the district is the ordinary alluvial plain of the Gangtic Delta; the western part consists of undulating beds of laterite resting on a rock basis, and covered with small scrub jungle. The Ajai, Bakheswar, and Mor or Maurakshi, are the principal rivers of the district, but they are merely hill streams and only navigable in the rains. Rice, wheat, sugar-cane, pulses, oil-seeds, and mulberry form the agricultural products of the district. The chief manufactures are silk, silk cloth, and

lacquered ware. The principal seats of trade are Dubrájpur, Pámbázár, Bolpur, Sinthiá, Purandarpur, Krinnáhár, Muhammad Bázár, and Ahmadpur. The total net revenue of the district in 1870–71 amounted to £97,979; the civil expenditure to £27,278. The land tax forms the most important item of revenue. In 1870–71 it amounted to £73,261, paid by 556 estates, held by 2036 proprietors, under the Permanent Settlement as in other parts of Bengal. The district and municipal police force amounted to 320 officers and men, at a total cost of £5895 in 1871. Besides these there were 8554 men of the village watch, maintained at a total cost of £23,074, paid by service lands and by the villagers. In 1872 Bírbbúm contained 604 schools, attended by 9338 pupils, costing £989 to the state for the education of its people. There are seven principal roads in the district, the total mileage being 191, and the average cost of their maintenance £1784. Thirty-three miles of the East Indian Railway lie within the district. Until lately Bírbbúm was considered to be the healthiest district in Bengal; but during the past few years epidemic fever has made havoc among the rural population of the eastern portion of the district.

**BÍRBHÚM**, or **SURÍ**, the principal town and administrative headquarters of the district of the same name, is situated in 23° 54' 25" N. lat., and 87° 34' 23" E. long. In 1872 it contained a population of 9001, of whom 6746 were Hindus, 2056 Mahometans, 187 Christians, and 12 of unspecified religions. Municipal income of the town in 1871, £483, 18s.; expenditure, £473, 8s.; rate of municipal taxation, 1s. 8d. per head.

**BIRCH** (*Betula*), a genus of arboraceous plants constituting the principal portion of the natural order *Betulaceæ*. The various species of birch are mostly trees of medium size, but several of them are merely shrubs. They are as a rule of a very hardy character, thriving best in northern latitudes,—the trees having round, slender branches, and serrate deciduous leaves, with barren and fertile catkins on the same tree and winged seeds. The bark in most of the trees occurs in fine soft membranous layers, the outer cuticle of which peels off in thin white papery sheets. The common birch (*B. alba*) grows throughout the greater part of Europe, and also in Asia Minor, Siberia, and North America, reaching in the north to the extreme limits of forest vegetation, and stretching southward on the European continent as a forest tree to 45° N. lat., beyond which birches occur only in special situations or as isolated trees. It is one of the most wide-spread and generally useful of forest trees of Russia, occurring in that empire in vast forests, in many instances alone, and in other cases mingled with pines, poplars, and other forest trees. The wood is highly valued by carriage-builders, upholsterers, and turners, on account of its toughness and tenacity, and in Russia it is prized as firewood and a source of charcoal. A very extensive domestic industry in Russia consists in the manufacture of wooden spoons, which are made to the extent of 30,000,000 annually, mostly of birch. Its pliant and flexible branches are made into brooms; and in ancient Rome the fasces of the lictors, with which they cleared the way for the magistrates, were made up of birch rods. A similar use of birch rods has continued among pedagogues to times so recent that the birch is yet, literally or metaphorically, the instrument of school-room discipline. The bark of the common birch is much more durable, and industrially of greater value, than the wood. It is impermeable to water, and is therefore used in northern countries for roofing, for domestic utensils, for boxes and jars to contain both solid and liquid substances, and for a kind of bark shoes, of which it is estimated 25 millions of pairs are annually worn by the Russian peasantry. The jars and boxes of birch bark made by Russian peasants are often stamped

with very effective patterns. By dry distillation the bark yields an empyreumatic oil, called *diogott* in Russia, used in the preparation of Russia leather; to this oil the peculiar pleasant odour of the leather is due. The bark itself is used in tanning; and by the Samoiedes and Kamchatkans it is ground up and eaten on account of the starchy matter it contains. A sugary sap is drawn from the trunk in the spring before the opening of the leaf-buds, and is fermented into a kind of beer and vinegar. The whole tree, but especially the bark and leaves, has a very pleasant resinous odour, and from the young leaves and buds an essential oil is distilled with water. The leaves are used as fodder in northern latitudes. The species which belong peculiarly to America (*B. lenta*, *excelsa*, *nigra*, *papyracea*, &c.) are generally similar in appearance and properties to *B. alba*, and have the same range of applications. The largest and most valuable is the black birch (*B. lenta*), found abundantly over an extensive area in British North America, growing 60 to 70 feet high, and 2 to 3 feet in diameter. It is a wood most extensively used for furniture and for carriage building, being tough in texture and bearing shocks well, while much of it has a handsome grain, and it is susceptible of a fine polish. The bark, which is dark brown or reddish, and very durable, is used by Indians and backwoodsmen in the same way as the bark of *B. alba* is used in Northern Europe. Concerning the canoe or paper birch (*B. papyracea*), which some regard as a variety of the white birch, Mr Bernard R. Ross, of the Hudson's Bay Company, writes:—"The canoe or paper birch is found as far north as 70° N. on the American continent, but it becomes rare and stunted in the Arctic circle. It is a tree of the greatest value to the inhabitants of the Mackenzie River district in British North America. Its bark is used for the construction of canoes, and for drinking-cups, dishes, and baskets. From the wood, platters, axe handles, snow-shoe frames, and dog sledges are made, and it is worked into articles of furniture which are susceptible of a good polish. The sap which flows in the spring is drawn off and boiled down to an agreeable spirit, or fermented with a birch-wine of considerable alcoholic strength. The bark is also used by the Christianized American Indians as a substitute for paper." A species (*B. Bhajputtra*) growing on the Himalayan Mountains, as high up as 9000 feet, yields large quantities of fine thin papery bark, extensively sent down to the plains as a substitute for wrapping-paper, for covering the "snakes" of hookahs, and for umbrellas. It is also said to be used as writing paper by the mountaineers; and in Kashmir it is in general use for roofing houses.

BIRCH, THOMAS, historical and biographical writer, and one of the early trustees and benefactors of the British Museum, was born in London, November 23, 1705. He was the son of a coffee-mill maker, and was to have followed his father's business; but his active mind and ambition of higher pursuits led him into the paths of literature. His parents were members of the Society of Friends, and therefore he had not the advantages of a university training. But by persevering application to study and to teaching he qualified himself for the ministry of the Church of England. In 1728 he obtained a curacy, and in the same year he married. His wife died in the following year. He was ordained priest in December 1731, and was soon after recommended to the favour of Philip Yorke, then attorney-general, afterwards Lord Chancellor and earl of Hardwicke, to whom he owed his successive preferments in the church. His first benefice was the vicarage of Ulting in Essex. In 1734 he was appointed domestic chaplain to the earl of Kilmarnock, who was beheaded for his share in the rebellion of '45. He afterwards held successively benefices in Pembrokeshire, Gloucestershire, and the city of London. His last church

preferment was to the rectory of Depden in Essex, to which he was presented in February 1761. In his latter years he was appointed chaplain to the princess Amelia. His literary attainments procured him election as a fellow of the Royal Society in February 1735, and in the following December he was chosen a member of the Society of Antiquaries. He held the office of Secretary to the Royal Society for thirteen years 1752-1765. From the university of Aberdeen he received the degrees first of M.A., and afterwards (1753) of D.D. The degree of D.D. was also conferred on him about the same time by the archbishop of Canterbury. Dr Birch was engaged in a large number of literary undertakings. His appetite and his capacity for hard work were extraordinary. Besides his diversified labours of compilation and editing, he transcribed many volumes in the library of Lambeth Palace, and carried on an extensive correspondence with literary men. He was an early riser; and amidst all his labours he found time to take part in social enjoyments. He was only in his sixty-first year when he was killed by a fall from his horse in Hampstead Road, January 9, 1766. He bequeathed his books and manuscripts, with part of his pictures and prints, to the British Museum. The rest of his property, in value about £500, he gave to be invested in Government securities, the interest to be applied in augmenting the salaries of the three assistant librarians.

His principal publications were—1. *The General Dictionary, Historical and Critical*, including a new translation of Bayle, and interspersed with several thousand new lives, in 10 volumes fol., 1781-1741. 2. *Thursi's State Papers*, 7 vols. folio, 1742. 3. *Dr Cuiworth's Intellectual System, improved from the Latin edition of Mosheim*; his *Discourses on the true Notion of the Lord's Supper*; and two *Sermons, with an Account of his Life and Writings*, 2 vols. 4to, 1743. 4. *The Life of the Honourable Robert Boyle*, 1741, prefixed to an edition of that philosopher's works. 5. *The Lives of Illustrious Persons of Great Britain*, to accompany the engravings of Houbraken and Vertue, 1747-1752. 6. *An Inquiry into the Share which King Charles I. had in the Transactions of the Earl of Glamorgan*, 1747, 8vo. 7. An edition of *Spenser's Faery Queen*, 1751, 8 vols. 4to, with prints from designs by Kent. 8. *The Miscellaneous Works of Sir Walter Raleigh, with his Life*, 1751, 2 vols. 8vo. 9. *The Theological, Moral, Dramatic, and Poetical Works of Mrs Catharine Cockburn, with a Life*, 1751, 2 vols. 8vo. 10. *The Life of Dr Tillotson, Archbishop of Canterbury, compiled chiefly from his Original Papers and Letters*, 1762, 8vo. 11. *Milton's Prose Works*, 1753, 2 vols. 4to, with a Life. 12. *Memoirs of the Reign of Queen Elizabeth, from the year 1581 till her death*; illustrated from the original papers of Anthony Bacon, Esq., and from other MSS., 1754, 2 vols. 4to. 13. *The History of the Royal Society of London, 1756 and 1757*, 4 vols. 4to. 14. *The Life of Henry Prins of Wales, eldest son of James I., compiled chiefly from his own papers and other MSS.*, 1760, 8vo. 15. *The Letters, Speeches, &c. of Lord Chancellor Bacon*. His numerous communications to the Royal Society may be seen in the *Philosophical Transactions*.

BIRD, WILLIAM, an English composer, and one of the best organists of his time, was born about 1540, and died at London, 4th July 1623. He was appointed organist of Lincoln cathedral in 1563; and in 1575 he and his master Tallis were gentlemen of the chapel royal, and organists to Queen Elizabeth. Bird was the earliest English composer of madrigals, and some of his numerous sacred compositions are still much esteemed. Most of them were published during his lifetime under a patent from Queen Elizabeth, which secured to him and Tallis the sole right to print and sell music. Between 1575 and 1611 there were issued under this patent eight different collections of his works, with such titles as *Cantiones Sacrae*; *Gradualis*; *Psalmes, Songs, and Sonets*, &c. The vocal canon *Non nobis Domine*, generally attributed to him, is well known, and often sung. He also wrote a number of pieces for Queen Elizabeth's Virginal Book, and other similar collections. In his compositions there is a freedom and elegance rarely found in the music of his period. A full account of Bird's life by E. F. Rimbault is prefixed to one of his Masses, published by the Musical Antiquarian Society.

## BIRDS

## ANATOMY OF BIRDS.

IN the consideration of the Anatomy of Birds, classification will be quite a secondary matter, and merely employed for the elucidation of internal structure. Some sort of grouping, however, is indispensable; and that is accordingly adopted, as the most convenient for the morphologist, which was first proposed by Professor Huxley,<sup>1</sup> with the introduction of certain modifications rendered necessary by the present writer's own researches—researches, it may be added, which have been carried on in constant communication with that investigator.

A little examination will show that the groups made by consideration of any, even the most important, morphological modifications, cannot be *superimposed upon* groups made by reference to the whole sum of the characters of the Bird. This may be easily explained. About half the known Birds, 5000 or thereabouts, belong, according to (J. R. Gray, to Professor Huxley's group, the *Coracomorpha*. These birds undergo a peculiar metamorphosis of the naso-palatal structures, and are called by Professor Huxley the *Ægithognatha* on that account. Now all the *Coracomorpha* have the ægithognathous palate, but so also have the *Cypselidae*, or Swifts, which are placed by this author with the Humming-birds and Goatsuckers, both of which groups are simply schizognathous. Moreover, below the Passerine types, and only next above the Semi-struthious Tinamous, we find the Hemipods, *Turnicidae*, or *Turnicimorpha*, and these have an ægithognathous palate. So also has another type, *Thinocorus*, which lies on the same low zoological level as the Hemipods. This latter bird is essentially a small Geranomorph, but it is below the true Cranes, and unites in its palate characters belonging to the Ostriches below it and the Passerines which ascend, zoologically, far above it.

The difficulty of applying this very valuable morphological grouping, and making it fit in with one that is more general and distinctively zoological (that is, having reference to every character, external and internal), does not take away anything of real value from it. To the anatomist such a mode of viewing the various types is perfectly natural, however hard it may be to satisfy the pure zoologist as to its great value. Certainly, the structures of the skull and face govern the whole body, as it were; every other part of the organism corresponds to what is observable there. Nor must it be forgotten that the true mode of studying any kind of creature is that of its *development*; and the head undergoes the most remarkable morphological changes.

In the following scheme we have added one new morphological group to Professor Huxley's classification. This group includes the Woodpeckers and Wrynecks, *Picidae* and *Yungidae*. Zoologically it forms the family *Celeomorpha* (Huxley); its morphological term is *Sauromorpha* (Parker).

<sup>1</sup> "On the Classification of Birds; and of the taxonomic value of the modifications of certain of the cranial bones observable in that class." *Proceedings of the Zoological Society*, April 11, 1867, pp. 415-472. This classification is somewhat modified in a later paper by the same author, in which a very masterly description is given of the Gallinaeous group (*Alectoromorpha*, Huxley), "On the Classification and Distribution of the *Alectoromorpha* and *Heteromorpha*," *ibid.*, May 14, 1868, pp. 293-319. The same author repeats, in essentially the same form, the original classification in his *Anatomy of the Vertebrated Animals* (1871, p. 272). The materials from which the modified views here given have been taken are in a series of contributions by Mr Parker to the *Transactions of the Linnean and Zoological Societies* now (1875) passing through the press. For figures of the skeleton see Mr Epton's *Osteologia Avium*.

Every one who has laboured at the anatomy of this class must have been struck by its marvellous uniformity; almost countless numbers of species are found passing insensibly into one another, and differing in the slightest manner. The best modern zoologists are at times almost at their wits' end to know by what characters they may distinguish their genera and species. This has been well put by Professor Huxley (*Anat. of Vert. Anim.*) He says (p. 272)—"Though this class contains a great number of specific forms, the structural modifications which they present are of comparatively little importance; any two birds which can be selected differing from one another far less than the extreme types of the *Lacertilia*, and hardly more than the extreme forms of the *Chelonica*, do. Hence the characters by which the following groups" (see subjoined table) "are separated appear almost insignificant when compared with those by which the divisions of the *Reptilia* are indicated."

## MORPHOLOGICAL CLASSIFICATION OF BIRDS.

A. The metacarpals not ankylosed together. The tail longer than the body.

## I. SAURURM.

1. *Archaeopterygida*.

B. The metacarpals ankylosed together. The tail considerably shorter than the body.

A. The sternum devoid of a keel.

## II. RATITÆ.

a. The wing with a rudimentary, or very short, humerus, and with not more than one ungual phalanx.

a. A hallux.

2. *Apterygida* (the Kiwis).

β. No hallux.

3. *Dinornithida* (the Moas).

4. *Casuariida* (the Cassowaries and Emus).

β. The wing with a long humerus, and with two ungual phalanges.

a. The ischia uniting immediately beneath the sacrum, and the pubes free.

5. *Rhida* (the American Ostriches).

β. The ischia free, and the pubes uniting in a ventral symphysis.

6. *Struthionida* (the Ostriches).

B. The sternum provided with a keel.<sup>2</sup>

## III. CARINATÆ.

a. The vomer broad behind, and interposing between the pterygoids, the palatines, and the basi-sphenoidal rostrum (*Dromæognathæ*).

7. *Tinamomorpha* (the Tinamous).

β. The vomer narrow behind; the pterygoids and palatines articulating largely with the basi-sphenoidal rostrum.

a. The maxillo-palatines free.<sup>3</sup>

i. The vomer pointed in front (*Schizognathæ*).

8. *Charadriomorpha* (the Plovers).

9. *Cecomorpha* (the Gulls).

10. *Spheniscomorpha* (the Penguins).

11. *Geranomorpha* (the Cranes).<sup>4</sup>

12. *Alectoromorpha* (the Fowls).

13. *Pterocloromorpha* (the Sand-Grouse).

14. *Peristeromorpha* (the Pigeons).

15. *Heteromorpha* (the Hoazins).

16. *Coccyomorpha* (part), (the Goatsuckers).

<sup>2</sup> The keel is but little developed in *Strigops* (*Ptilinoides*), in *Diada* (*Didida*), and in *Aptornis* (*Rallida*).

<sup>3</sup> Professor Huxley here gives in a note two exceptions, namely, *Crax* and *Dicholophus*. The latter bird, the Cariama, is, however, as Mr Parker has shown, a low, gruff, rapacious bird, having its maxillo-palatines united by suture, and being an example of a bird with *imperfect direct œsmognathism*.

<sup>4</sup> With the exception of *Thinocorus*, see below.

17. *Trochilomorpha* (the Humming-Birds).
  - ii. The vomer truncated in front (*Megithognathæ*).
18. *Ceraniomorpha* (part), (the exceptional sub-family *Thinocorina*, *Thinocorus*).
19. *Tyrannomorpha* (the Hemipods).
20. *Cypselomorpha* (the Swifts).
21. *Coraemorpha* (the Passerines).
  - iii. The vomerine halves permanently distinct, and the maxillo-palatines arrested (*Saurogathæ*).
22. *Coleomorpha* (the Woodpeckers).
  - a. The maxillo-palatines united, either by coalescence with the ossified septum nasi; or, 2d, by meeting at the mid-line and forming a suture; or, 3d, in the fullest degree, by complete ankylosis of the right and left plates.
23. *Acetomorpha* (the Birds of Prey).
24. *Fritacomorpha* (the Parrots).
25. *Coccygomorpha* (the Cuckoo, Kingfishers, and Trogons).
26. *Chenomorpha* (the Anserine Birds).
27. *Amphimorpha* (the Flamingoes).
28. *Pelargomorpha* (the Storks).
29. *Dyspseromorpha* (the Cormorants).

The above scheme is a nail in a sure place; and on it, for the present, we may hang all that we know, or are learning, of the anatomical structure of this class of Vertebrates. That which relates to the *Carinata* must, however, be regarded merely as a list of Birds having a similar facial structure.

For the general ornithologist it is very suggestive and helpful, and will save him from looking merely on outward appearances; for the study of structure and development is looking into the heart of the matter.

#### THE SKULL.

To both the zoologist and the paleontologist an explanation of the *skeleton* will be of the greatest value, for the framework must of necessity be correlated to the nervous system, and also govern the development of the muscles. It will here form the first and the largest part of our work. And as all things in the skeleton are conformed to the modifications of the skull, and, moreover, as the skull is the most knotty problem to the morphologist, it will receive the attention due to its superior importance.

Instead of describing the adult skull, and then showing how it develops, it would seem to be better to follow the stages of its growth, and thus see the meaning of the parts, and what metamorphic changes take place to give it its adult characters. Space will not permit any detail of the general embryology of the Bird, but the skull will be described from the time when the rudiments of the chondro-cranium are first fairly visible, that is, about the fifth day of incubation.<sup>1</sup>

As the *Schisognathous* type of skull, such as is seen in the Fowl, is the simplest variety found in the *Carinata*, it will be the most convenient for comparison with that of the *Rathke* and the *Tinamous* (the *Dromæognathous* variety) below, and the *Demognathous*, and other kinds seen in Birds above the *Gallinacea* in the zoological scale.

*The Cranium of the Fowl—First Stage.*—The chondro-cranium may be seen at the end of the fourth and the beginning of the fifth day of incubation, although the cartilage has as yet but little consistence, its cells being imperfectly soldered together. The head of the skull at this stage still

shows the "visceral clefts;" and it is bent upon itself by what is called the *mesocephalic flexure*. When the membranous roof of the skull and the brain are removed at this stage, the whole floor is not seen from above, the fore-part being bent under and looking backwards.

In the hinder half of the skull-floor, behind the eyeballs, we see a broad plate of tissue (fig. 1, *comp.* fig. 2, *et.*) which is passing rapidly from the condition of stellate cells into proper hyaline cartilage.

This plate is divided at the mid-line by a straight, somewhat beaded rod of soft indifferent tissue, which does not chondrify; it is rounded at its fore-end. This truly asygon part is the notochord (n.c.), or primary axis of the skeletal parts of the embryo; it lies directly beneath the neural axis, and is one of the parts earliest visible to the embryologist. The broad plate on each side is seen to be hollow, and to contain a pear-shaped diverticulum of the primordial ear-sac (cl.), which is planted, as it were, in the very substance of the basal plate, at its middle. The outer granular covering of the ear-sac becomes cartilage, and so does the basal plate—the "investing mass" of Rathke, the "parachordal cartilage" of Huxley.<sup>2</sup>

But the process by which these two separate morphological territories become converted into solid cheese-like cartilage is carried on blindly, as it were, and no distinction of parts is at present traceable; evident differentiation of morphological territories is often late in the higher types of vertebrata. The tissue which surrounds the spinal chord where this part passes into the brain is still soft; it will chondrify soon to form the occipital arch. The bulbous end of the notochord ends a little behind at oval membranous space or fontanelle in the skull-floor—the *pituitary space* (p.s.). Near the end of the notochord, on each side, the cartilage suddenly narrows, for here we are in front of the impacted ear-sacs; at this part a bending of the narrow anterior end of the parachordal rounded notch (b) is formed, over which the trigeminal nerve passes. The anterior margin of the notch (afterwards formed into the *foramen ovale*) is formed by the cartilage; its actual extremity looks forward and outward, towards the eyeball. At present the bands which are continued forward, surrounding the pituitary space, are superimposed upon, and indistinct from, the ends of the parachordal cartilages; in the next stage they will be seen more distinctly. These flat bands of dense granular tissue are the *trabeculae cranii* of Rathke (tr.), and they were supposed by him to be mere continuations of the parachordal bands, an error corrected some years ago by Professor Huxley. These little rafters of the cranium bend gently round the oval pituitary space; they then con-

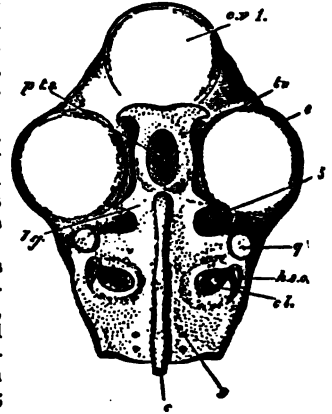

FIG. 1.—Skull of Chick after four days of incubation, with head three lines long. First stage, from above,  $\times 9$  diameters. Most of the brain has been removed. c.s.l., first cerebral vesicle; p.s., pituitary space; tr., trabeculae cranii; cl., lingula formed by junction of trabeculae with the parachordal cartilages on each side of notochord (n.c.); c. eye; q., cochlea; g., quadrate cartilage; a.s., horizontal semicircular canal; b., foramen ovale; h., hypoglossal nerve.

<sup>1</sup> The whole development of the *Chick* is explained in a masterly and lucid manner by Messrs Foster and Balfour in their excellent work, *The Elements of Embryology*, London: Macmillan and Co. Part I, 1874. The description of the fowl's skull here given is principally from Mr Parker's paper, *Phil. Trans.*, 1869, plates 81-87, pp. 765-807. For a detailed description of the anatomy of birds, see Dr H. G. Bronn's *Klassen und Ordnungen des Thierreichs*, 1869, 6te Band, IV. Abtheilung, "Vögel."

<sup>2</sup> See Huxley on "Menobranchus," *Proceedings of Zoological Society*, March 17, 1874, p. 197.

pletely unite into a broad inter-nasal plate, which is bent over upon itself so as to appear on the under surface of the face.

The inter-nasal plate is arched and winged—the rudi-

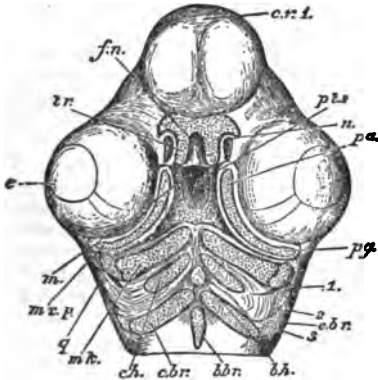

FIG. 1.—The same as fig. 1, seen from below. *f.n.*, fronto-nasal plate; *n.*, external nostril; *m.*, mouth; *m.p.*, maxillo-palatine, containing pterygo-palatine bar (*pp.p.*); *m.k.*, Meckel's rod, or free mandibular bar; *c.a.*, cerato-hyal; *b.a.*, basal-hyal; *c.b.r.*, cerato-branchial; *e.b.r.*, epi-branchial; *b.b.r.*, basi-branchial; 1, 2, 3, 4, 1st, 2d, and 3d visceral clefts.

mentary condition of the nasal sacs, the apertures of which are seen beneath the arched part below (fig. 2, *n.*)

The trabeculae, antero-inferiorly, become free again; these free extremities are the ventral ends of this the first visceral arch; they form the pith of the flat, emarginate rudimentary *neb.* This part is called the "fronto-nasal process" (fig. 2, *f.n.*)

On the sides of the face behind the mouth are seen slits (fig. 2, 1, 2, 3); these are the "visceral clefts," which are always developed in embryonic vertebrata. Between these clefts the tissue of the "mesoblast" is thickening into cartilaginous rods; these rods are the post-oral visceral arches, the rudiments of the lower jaw and hyoid bone. But beneath the eye is seen an arcuate bar of tissue more solid than its surroundings; this is the pterygo-palatine rod. It is developed in the maxillo-palatine process of the mandibular or first post-oral arch; it represents the bar of cartilage which, in the Frog, connects the mandibular suspensorium with the ethmoidal region.<sup>1</sup>

The first visceral arch, then, runs along in front of the parachordal cartilages; the trabeculae cranii are its right and left moieties. The second arch can only be understood by reference to the development of the lower types of Vertebrata; for in the Shark, Skate, Newt, and Frog the pterygo-palatine portion is not a distinct cartilage, but runs forward as a process of the suspensory part of the lower jaw. But this early division of a visceral arch into an antero-superior and a postero-inferior bar is very constant in the next or second visceral arch from the Skate up to Man. Let it be remembered that the cartilaginous stage is the second; in the first stage the skeletal parts are membranous. They are formed of soft stellate cells in the mesoblast.<sup>2</sup>

At present the subocular pterygo-palatine bar is very little denser than the tissue in which it is imbedded, but the mandible itself is fast passing into cartilage. Already it is in two pieces, a suspensory piece (figs. 1 and 2, *g.*), and a free rod (*m.k.*); the upper piece becomes the quadrate, and the lower, longer part the articulo-Meckelian bar. The processes of the tuberosus upper piece are indistinct, but it is sinuous below where it articulates with the thick

<sup>1</sup> See article AMPHIBIA, vol. 1. p. 755, fig. 9, between *pd.* and *d.O.*

<sup>2</sup> See Foster and Balfour's work, p. 223.

end of the free bar. These bars nearly, but not quite, meet in the rudimentary chin, the ventral end of the lower jaw. Properly speaking, the hyoid arch is composed of two visceral arches; but the term is now applied strictly to the first of these, namely, the second visceral, or the arch of the tongue. At present this arch has, with the one in front of it, its antero-superior piece quite soft; it, too, is late in its development. The two lower pieces (fig. 2, *c.a.*) form the skeleton of the tongue. They are the ceratohyals, and between these is a small basi-hyal (*b.a.*) answering to the first basi-branchial of a Fish. The third post-oral arch is very similar, but it is larger, and its upper piece is already fast chondrifying. That corresponds to the first epi-branchial of a Fish, the lower piece to the first cerato-branchial, and the median wedge to the second basi-branchial.<sup>3</sup>

*Cranium of Fowl—Second Stage.*—In from twenty-four to thirty hours, or about the beginning of the sixth day of incubation, the chondro-cranium of the chick has undergone sundry and notable changes. A sectional view (fig. 3)

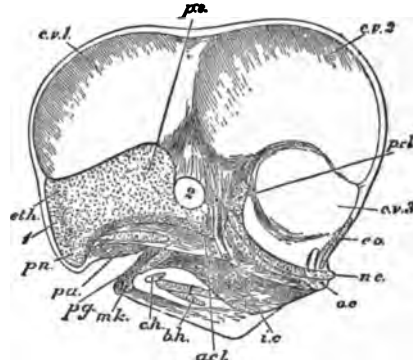

FIG. 2.—Head of Chick, second stage, after five days of incubation; length of head, 4 lines; X 6 diameters; a vertical section. *c.v.1*, *c.v.2*, *c.v.3*, 1st, 2d, and 3d cerebral vesicles; 1, 2, localities of first and second nerves (olfactory and optic); *p.n.*, pronasal cartilage; *eth.*, ethmoid; *a.c.*, anterior clinoid wall; *p.c.*, posterior clinoid wall; *n.c.*, notochord; *o.c.*, occipital condyle (from this point to *p.a.* the cartilage is parachordal); *a.e.*, exoccipital; *i.c.*, internal carotid artery; *p.e.*, palatine; *p.g.m.k.*, pterygo-mandibular region; *m.k.*, Meckel's cartilage; *c.a.*, cerato-hyal; *b.a.*, basi-hyal; *p.e.*, presphenoidal region.

shows that the hinder and front cartilages, parachordal and trabecular, are applied to each other unconformably, the parachordal tracts rising high between the second and third cerebral vesicles, and forming the posterior pituitary wall, a shelving structure in which the axial skeleton ends.

A bird's-eye view of the hinder skull-floor at this stage (fig. 4) shows that the dorsal or hinder ends of the trabeculae have opened out, like a pair of callipers, and that the out-turned ends of the parachordal cartilages are fused with the inner margin of these apices. The bud-shaped process, which has almost freed itself from the rest, opposite the bulbous end of the notochord, is the true apex of the first visceral bar, or trabeculae; in the next stage it is far more distinct and instructive. Turning again to the vertical section (fig. 3), we see that the commissure of the trabeculae, or inter-nasal plate,<sup>4</sup> has now become a high wall of cartilage, separating not only the nasal sacs, but also the eyeballs.

That part of the septum which now looks, not only downwards, but is also turned somewhat backward (fig. 3, *eth.*), will ultimately lie in the upper part of the nasal and frontal regions. A new thing has appeared, namely, an

<sup>3</sup> See Parker "On the Salmon's Skull," *Phil. Trans.*, 1873, plate 6, fig. 3. See also plate 2 of the same paper for the subdivision, in a Teleostean Fish, of the hyoid arch.

<sup>4</sup> This corresponds to the flattened, narrow mesethmoid of Mamebranchus. See AMPHIBIA, vol. 1. pp. 756, 757, figs. 11, 12.

azygous cartilaginous bud at the mid-line of the fronto-nasal process; it is about to become the axis of the beak, and will turn forwards and upwards. This is the prenasal or basitracular cartilage, a notable morphological element up here, amongst the Birds, and down amongst the lower or cartilaginous types of Fishes. At the present it corresponds exactly to the state of the Green Turtle's skull (chondrocranium) at the time of hatching, and in that type it stops at this stage, not raising itself into a forthcoming rostrum.

The mouth, which in the first stage was a large four-sided cleft, with produced corners, and clean beneath the head, as in a Skate, is now a space, the axis of which points more forward than downward, a good step towards its eventual direction. The further development of the facial arches will be best studied in older specimens at the end of this, the second stage; but at its commencement there is wanted the condition of the antero-superior segment of the hyoid, or second post-oral arch. This has not been worked out in the Fowl's chick, but in an embryo of the House Martin (*Chelidon urtica*), corresponding to the stage given in our third figure as to development.

In this instance the quadrate and articular Meckelian cartilages have acquired very nearly their proper form (fig. 5, *q.*, *ar.*, *mk.*), the suspensorial part having a free for-

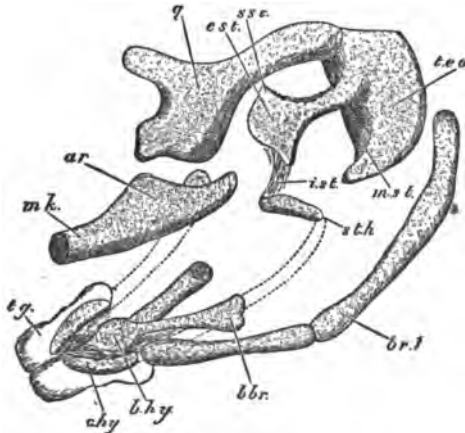

FIG. 5.—Facial arches of House Martin (*Chelidon urtica*), middle of incubation, X 50 diameters. *q.*, quadrate, with orbital process or "pedicle" in front; "otic process" behind, and articular face below; *ar.*, articular part of mandible; *mk.*, Meckel's cartilage (cut through); *m.s.t.*, medio-stapedial (the line from the letters only reaches half-way to this bar); *s.s.*, supra-stapedial; *est.*, extra-stapedial; *ist.*, infra-stapedial (soft); *st.h.*, stylo-hyal; *t.e.o.*, tympanic wing of exoccipital; *tg.*, tongue; *ch.h.*, cerato-hyal; *b.h.y.*, basi-hyal; *b.br.*, basi-branchial; *br.1.*, 1st branchial or thyro-hyal.

ward and inward looking process, the "pedicle," and a backward turned process, the "otic process," articu-

lating with the auditory sac (this is drawn as cut away in part, and only that which is conjoined to the occipital cartilage (*t.e.o.*) is given). Just below and behind the otic process of the quadrate, exactly where in riper embryos we find the *fenestra ovalis*, having fitted into it the elegant oval base of the "columella auris," there is in this instance a curious trowel of cartilage, continuous by the upturned end of its handle with the very substance of the ear-capsule. The solid sickle-shaped cartilage behind this is the "tympanic wing" of the exoccipital (*t.e.o.*) Here we have the wanting upper and anterior segment of the hyoid arch, corresponding to the separately developed pterygo-palatine bar, its "serial homologue." The blade or free end of the trowel is concave on the under side, and is thick above and at its margin on the outside; it is pointed above and below. A ligament connects the upper point with the ear-capsule behind the quadrate, and another tract of soft *indifferent tissue* reaches downwards to a small bar of cartilage, which looks backwards and a little downwards. This little cartilage (*st.h.*) is only connected with the distal piece (*ch.h.*) by fibrous tissue; it is the stylo-hyal, and corresponds to what is permanent in the Crocodile. The bar itself is the "medio-stapedial" (*m.st.*); it will soon segment itself off from the ear-capsule, bringing away with it an oval piece of the periotic wall; that oval part is the true stapes. The broad part of the "blade" is the extra-stapedial, and on it will be stretched the *membrana tympani*; It precisely corresponds now with that of that old Lacertian *Hatteria* or *Sphenodon*.<sup>1</sup>

The "stylo-hyal" will soon be conjoined to the extra-stapedial plate, and the (afterwards) chondrified band will be the "infra-stapedial."<sup>2</sup>

In a few hours the changes that have taken place in the chick's skull are very noticeable and important; these are recorded as the end of the second stage.

A side view of the chondrocranium (fig. 6), the men-

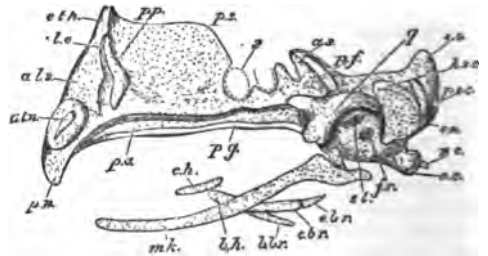

FIG. 6.—Skull of Chick, second stage, head 6 lines long, X 6 diameters. Outer view, with brain and roof removed to show chondrocranium. Letters as in figs. 1-4, with the addition of *a.s.*, alitrans cartilage; *a.l.a.*, alisphenoid; *a.s.*, alitrans cartilage; *p.p.*, para plana; *a.s.*, alisphenoid; *p.f.*, post-frontal (epineurial region); *a.o.*, super-occipital; *st.*, stapes; *f.r.*, foramen rotundum; *p.s.c.*, posterior semicircular canal.

brano-cranium above the brain being removed, shows how fast the life-processes are moulding the embryonic head into the fashion seen in the adult; no trace of bone has appeared, save in the sides of the mandible. The roof of the skull never chondrifies, but is covered in by secondary bones. Like the skull of an adult Shark or Skate, the whole chondrocranium is one continuous structure—all save the post-oral arches. The auditory mass is now envired by cartilage stretching over the back of the head—the occipital, and by wing-like growths that wall-in the bulk of the brain behind the eyes—the alisphenoid (*a.s.*) The high

<sup>1</sup> See Huxley "On the Representatives of the Malleus and Incus of the Mammalia in the other Vertebrata," *Proc. Zool. Soc.*, May 21, 1869, pp. 394-397, figs. 1-4.

<sup>2</sup> For a comparison of these parts with the *ossicula auditus* of the Mammal, see also Parker "On the Structure and Development of the Skull in the Pig," *Phil. Trans.*, 1874, p. 331.

orbito-nasal wall is one continuous plate of cartilage, seemingly only a crest upgrowing from the coalesced tract of the trabecula. The arched wings of this part, which we saw in the first stage, can be seen to be marked off into three regions—an alisthoid (*al.e.*), an aliseptal (*al.s.*), and an alinasal (*al.n.*); in the latter is the external nostril, and dividing the eye from the nose is a flat partition, the *pars plana* (*p.p.*) Between the nasal openings and their curtains and valves, the prenasal cartilage (*p.n.*), still arcuate, is yet rising in front; whilst, behind and above, the great middle wall (*etk.*) terminates by a bud of cartilage, which marks the fore-end of the cranial cavity, and the groove on each side below this is for the nerve of smell (1). The oval pituitary space has become a neat round opening, through which the internal carotid arteries enter; it never chondrifies below, and has to be floored afterwards by secondary bone. The upper hyoid element (*st.*) has now freed itself from the periotic cartilage, bringing away so much as serves for the dilated dorsal end, and thus leaving an open window (*fenestra ovalis*), to which this forms the accurately fitted shutter. In front of this small cartilage, the quadrate (*q.*) shows almost its adult form, and the double lower condyle fits into a sinuous concavity on the end of Meckel's cartilage (*mk.*) This free bar—the mandible—sends backwards a posterior, and inwards an internal angular process. The later and feebler pterygo palatine sickles are now formed internally of small thin-walled spheroidal, and externally of fusiform, cells of a larger size. They ossify before chondrification can take place.

Interposed between the skin of the palate and fauces below and the basis cranii above, is a thick mat of granular tissue, which does not, however, chondrify, but ossifies as the parasphenoid and basi-temporal bones.

**Cranium of Fowl—Third Stage.**—After about three or four days, that is, about the middle of the second week of incubation, the chondro-cranium has not only undergone great changes in size and form, it is also now beginning to become an *osteo-cranium*.

All that is cartilaginous has acquired a neat finish (figs. 7, 8); the occipital condyle (*o.c.*) is perfect; the super-occipital arch is complete (fig. 8, *s.o.*); and bone is forming in three places in the occiput (*m.c.*, *e.o.*), and the bone (*pa.s.*) which underlies the orbital septum has grafted itself upon the cartilage of the basi-sphenoidal region. That bone, the parasphenoid (*r.b.s.*), and the other investing bones, are now growing in the tissue between the skin and the cranio-facial elements; those that can be seen below are shown in figure 8, the remainder can be described in riper stages. The downward bend (not shown in the figure) of the prenasal rostrum (*p.n.*) is but gentle; this long spatulate continuation of the base of the orbito-nasal septum, the "basi-trabecular bar," or foremost keystone piece of the body, is now at its fullest height of growth, and ready to decline. It is now the accurate

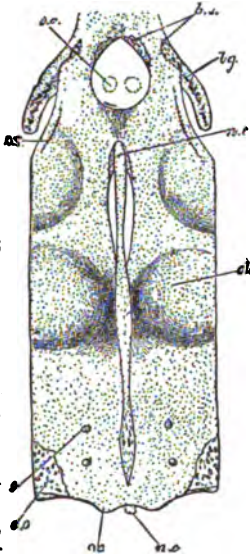

FIG. 7.—Skull of Chick, third stage, part of basal region, from above. X 13 diameters. *a.c.*, root of all-sphenoid; *h.s.*, basi-sphenoid. The notochord (*n.p.*) is seen to lie in an open space in front—the posterior basi-cranial fontanelle—and to be bony behind; the bony matter is the rudiment of the basi-occipital.

counterpart of the axis of the cutwater of such Fishes as the Skate, Saw-fish, and Shark. Those who look for the under-

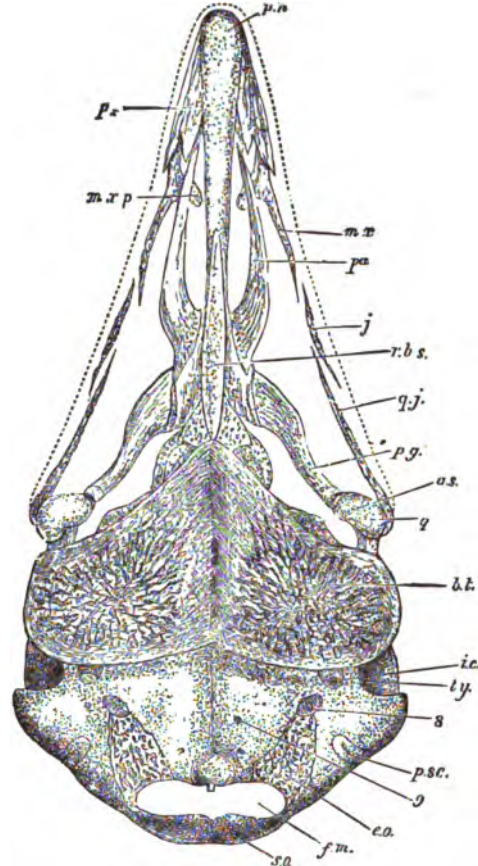

FIG. 8.—Skull of Chick, third stage, under view. X 10 diameters. Around the large prenasal cartilage *p.n.*, which, behind, runs into the septum nasale, are seen the premaxillaries (*p.s.*). These are the commencement of a chain of spines running to the quadrate (*q.*), viz., *m.x.*, maxillary; *m.x.p.*, its inner process; *j.*, jugal; *q.j.*, quadrate-jugal. Within these are—*pa.*, palatine; *pt.*, pterygoid; *r.b.s.*, rostrum of basi-sphenoid (parasphenoid); this is spreading into the basi-sphenoidal region, flanked by the lingulae, and above and behind are the alisphenoids (*a.s.*). In the broad part are the following, viz., *d.t.*, basi-temporals; *t.y.*, tympanic cavity; *f.m.*, foramen magnum; *a.c.*, the bony exoccipitals; *s.o.*, super-occipital. Other letters as above.

lying *unity* of the various types may here see how fit this unpaired rod is to have modelled on it all kinds of beaks of Birds. On this bar a tri-radiate patch of bone is formed right and left, leaving it as yet uncovered below, above, and at the fore-end. These are the young premaxillaries, and are bones that in most Birds, as in Osseous Fishes, overshadow and starve the upper jaw-bones, or maxillaries proper, so large, relatively, in most other types. Already they have each a palatine, a nasal, and a dentary process. The machinery of the first post-oral is shown (fig. 8), all save the free mandible, which will be described in a more advanced stage. The quadrate (*q.*) is ossifying; the pterygo and palatines (*pt.*, *pa.*) are ossified; they are very simple bars. Between the premaxillary and the quadrate are bones that have been formed in the outer part of the "maxillo-palatine process" of the embryo; they are the feeble maxillary, with its ingrowing maxillo-palatine plate, and the still feebler jugal and quadrate-jugal (*m.x.*, *m.x.p.*, *j.*, *q.j.*)

On the mid-line a grooved style of bone, the rostrum of the parasphenoid, carries the rounded lower edge of the

inter-orbital septum, and has grafted itself upon the cartilage of the pituitary ring, causing it also to ossify. On each side, behind these new bony patches, a free tongue of cartilage is seen. These tongues are the apices of the trabecular bars. They are better seen in the partial view (fig. 7). Underflooring the fore-half of the main skull base, close behind the pituitary ossifications, the thick mat of sub-mucous tissue is fast becoming bony. There is a right and left squarish patch, very large and elegant; in the grooved mid-line a few osseous points are also seen, ready to grow right and left into the two plates, and to make them one. These are the basi-temporals (*b.t.*) They soon coalesce with the ossifying basi-sphenoid above, and they represent the handle of the dagger-shaped parasphenoid of the Frog.<sup>1</sup> The super-occipital region (*s.o.*) is still soft, and the exoccipitals do not reach to the condyloid foramina (9). They begin at the hole for the *vagus*, and run to the selvage at the foramen magnum (8, *f.m.*) The kidney-shaped transverse condyle (*t.c.*) has in its substance the diminishing notochord (*n.c.*), which, however, is better seen in the partial upper view (fig. 7, *n.c.*) This figure shows that the notochord has tried, as it were, to break up into three fusiform segments. The hinder of these is enclosed in an ectosteal sheath, which will affect with bony growth the neighbouring cartilage, right and left, to form the basi-occipital. The fore-part is narrower, and lies in an open space, the counterpart of the membranous floor ("posterior basi-cranial fontanelle"—Bathke), which lies behind the pituitary space in the Snake's embryo. On each side of the middle notochordal spindle are seen the elegant mammillary elevations caused by the enclosed *cochleæ* (*cl.*) The internal carotids (*i.c.*) are seen creeping through the pituitary hole, and on each side the ossification has been set up, which forms the true endo-skeletal basi-sphenoid. On each side of the posterior pituitary or clinoid wall, the cartilage is pinched in to let the great trigeminal nerves pass over; but two parts of intensest interest are seen on each side of these shallow notches. These are the apices of the trabeculae (*tr.*), free-ended, curved tongues of cartilage, with dark cells in their interior, and fixed to the out-turned anterior ends of the parachordal cartilages, just where the new bony matter is seen. The meaning of these parts that make the pituitary region was not seen at the time by the author of the paper we are quoting (Parker "On the Fowl's Skull"); further research was needed, and his figures are of much greater value than his descriptions.

**Cranium of Fowl—Fourth Stage.**—At the beginning of the third week of incubation the chondro-cranium is not only perfect as to form, but it has also so much increased its bony territories as to make it very useful for comparison with *chondrosteous* skulls of the lower types. When every investing bone has been removed, we get such a structure as is shown (from above) in fig. 9. Here the cranial basin has a short and fenestrate floor, and doubly-winged sides, which are gently scooped above, and form a pair of symmetrical ledges on which the widest part of the brain rests; whilst the floor dips much lower down, where the medulla oblongata and the pituitary body rest. The scooped fenestrate aliphenoids (*a.s.*) look inward, but fail to reach the median line by a great space, which space is filled in by no orbital wings, such as we should see in a Lizard, Turtle, or Mammal. The whole orbital region is, in the skull, a steep wall, having a retral crest on its fore part, this crest being the rudiment of the large sheet of cartilage (*tegmen cranii*), which is thrown over the brain in the young Salmon.<sup>2</sup> This wall (*p.s.*), this crest, and the elegant cartilaginous awning in front of the crest, containing valves

and folded curtains of most cunning construction (see figs. 10 and 11)—all these have grown out of that intercranial

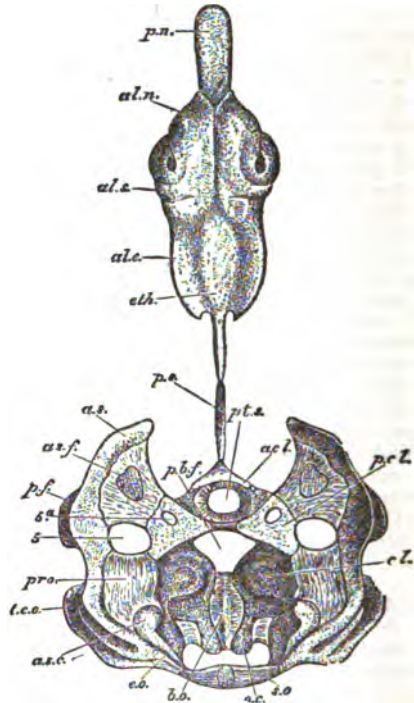

Fig. 9.—Skull of Chick, fourth stage, head nearly 1½ inch long, beginning of third week, X 4 diameters. The additional letters are—*a.s.*, aliphenoidal fenestra; *p.b.f.*, posterior basi-cranial fontanelle; *pro.*, prootic bone; *c.l.*, anterior semicircular canal; *t.c.*, transverse wing of exoccipital; *s.o.*, basi-occipital; *sa.*, foramen rotundum; *8*, foramen ovale.

plate formed by the trabeculae as their commissure (figs. 1 and 2, *tr.*)

Morphologically considered, these are added and distinct elements, but their differentiation from the trabeculae cannot be seen well until now, and even now it is imperfect. The leafy coverings of cartilage are seen to dip down on each side of the prenasal spatula in front, and the cartilage at this part forms a coiled, valvular nose-lid—the "alinasal region." From this, in its inside, there hangs a curtain, all of cartilage (fig. 10, *n.tb.*), the "alinasal turbinal." It curves towards the septum, and then turns upwards below to become parallel to the inturned nasal wall (*i.n.w.*) Behind the alinasal comes the aliseptal region (*a.l.s.*); and when cut across at the notch behind it and the hinder part of the roof, it shows a doubly coiled outgrowth, the "inferior turbinal" (fig. 11, *i.tb.*) The hinder region or "alioethmoid" is the true olfactory region; the roof suddenly turns inward, and is coiled upon itself, so as to form the bagpipe-shaped upper turbinals, whose swollen faces look inwards to the mesethmoid. Behind their inturned part they send down a cartilaginous curtain, the *pars plana*, or antorbital plate, the fore-face of which

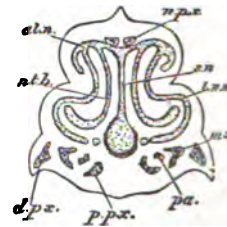

Fig. 10.—Skull of Chick, fourth stage, a transversely vertical section through the external nostrils, X 1 diameters. *a.s.*, septum nasi; *a.l.s.*, alinasal; *a.l.h.*, alinasal turbinal; *i.n.w.*, lateral nasal wall; *a.p.x.*, nasal processes of premaxillaries; *d.p.x.*, dentary processes of the same; *p.p.x.*, palatine processes of the same; *pa.*, palatine; *ma.*, maxillary. On each side of the thick base of the septum the nasal nerves are seen.

<sup>1</sup> See article AMPHIBIA, vol. i. p. 753, fig. 5, *p.s.*  
<sup>2</sup> See "Salmon's Skull," *op. cit.*, plate 4, fig. 2, *l.c.*





hatching, the skull of the chicken is excellent for comparison; as in Cattle, so in the Fowl and its relations, "their young ones are in good liking" as soon as they appear; hence they are strong in bone and sinew very early, the growth-processes taking place rapidly.

The under view (fig. 13) shows, behind the orbits, a strong cranial box. Synchondroses of the remainder of the chondrocranium divide the endo-skeletal bone-territories; and that organic attraction which causes the perfect correlation of the shallow with the deeper layers of the mesoblast, has given us here bony encasements, that not only fill in what was wanting in the chondrocranium, but also overlie and double the strength of the ossified cartilage itself. All is neat and finished now, and now is the nick of time in

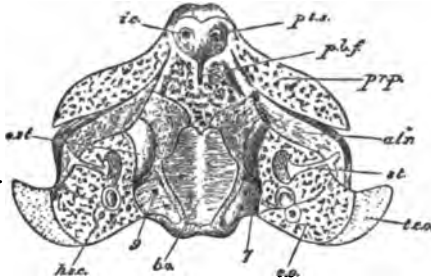

FIG. 14.—Horizontal section of skull-base of same Chick, X 4 diameters. *a.t.r.*, anterior tympanic recesses; *st.*, stapes; 7, portio mollis passage (meatus internus).

which can be seen most of the sutures, so soon to be obliterated by the almost universal ankylosis that takes place afterwards—a process by which Nature, in the Bird, rapidly fills in nearly all her footprints. Here she is as hard to bind as Proteus himself; and the morphological worker is often sore bested to catch all the transformations. If the chick were to retain throughout life its present form of face, it would much resemble a Hemipod. We have seen how its skull becomes metamorphosed from a lower into a higher and a still higher type day by day.

This basal view shows that the bony pieces of the occipital arch are fast forming a strong ring, after the manner of a vertebra. The keystone piece (*s.o.*) is now one bone, with the remains of the suture above. The notochord still exists in the basal piece (*b.a.*), and is seen in the condyle, the dimple of which is caused by it. The basi-temporal plate (*b.t.*) is now a low triangle, with its base behind; the base is, as it were, gnawed, the jagged edge joining the overlying spheno-occipital by a squamous suture. This thick plate is emarginate in front, below the meeting of the eustachian tubes (*eu.*), and this notch is the mark of the original symmetry of this double bone. Grooved gently at the mid-line, the basi-temporal is mammillate on each side, these elegant swellings being due to the ocellae that are encysted in the ossifying cartilage above. Behind, it is eared, and over these ears the internal carotids creep as they seek the pituitary space ready to form the "circle of Willis." The bone above and in front of the basi-temporal is a compound of the rostral parasphenoid and the proper basi-sphenoid. Altogether, this is a very extensive and multi-form element. Directly in front of the basi-temporal it is scooped at the meeting of the eustachian tubes—diverticula of the first visceral cleft. In front of that part the rostrum is soon a free structure, grooved for the interorbital septum; but behind and above the basi-temporal the bony mass is all one, and it has an upper and a lower wing on each side behind the strong wall which it has built around the pituitary well. The upper of these wings are ossifications of that cartilage which we saw was

formed by coalescence of the *sub-apical* part of the trabeculae with the fore-end of the parachordal plates.

The large posterior basi-cranial fontanelle has now become the deep chink which exists as a ditch between these post-pituitary banks (fig. 14, *p.b.f.*). On the upper surface the chink reaches the basi-occipital; in the horizontal section (fig. 14) it is cut away behind.

The lower and outer pair of wings of the basi-sphenoid are very large (figs. 13 and 14); they build, on each side, the anterior tympanic recess (*a.t.r.*), and their starting point of growth is from the free apices of the trabeculae, which are thus feathered with these large coiled laminae of periosteal bone that enclose another diverticulum of the first visceral cleft, which lies over the eustachian passage.

Close in front of the eustachian groove the soldered part of the rostrum widens into a pair of projections, and, upon these, obliquely placed facets of cartilage are attached for articulation with counterpart cartilages on the pterygoid bones (*pg.*)

These perfectly distinct cartilages are the result of a peculiar metamorphosis of the outstanding (basi-ptyerygoid) spurs of the trabeculae. In the *Ratites*, as in Lizards and Serpents on the one hand and Mammals on the other, these external pterygoid plates or processes are a direct outgrowth of cartilage, the posterior conjugational spurs that grow out for union with the pterygo-palatine arcada.<sup>1</sup> Like the subdivision of the ethmo-trabecular wall, this segmentation of originally continuous cartilage is of the highest morphological importance. Several other things of this kind will be found in this class, where the Vertebrate pattern has been specialized and metamorphosed to its highest degree, as if to produce types that should be as *isagones* in relation to the forms beneath them. The remainder of the rostrum just runs, pointed, to the edge of the cranio-facial cleft (fig. 16, *r.d.s.* to *a.p.*) In front of this notch the septum nasi is seen, narrow and rounded, and it terminates below in the starving prenasal (*s.n.*, *p.n.*) Around and in front of that rod the now single premaxillary clings; it has its under surface grooved to the end, where that rod lay, its sides developed into the sharp dentary region (fig. 13, *d.px.*), and its under part growing backwards as two nearly parallel bands, the palatine processes (*p.px.*), that articulate with the palatine bones (*pa.*) These latter bones run backwards in the same gently diverging manner, and then curve inwards to be tied the one to the other, before they bend outward again, foot-like, to articulate with the pterygoids (*pg.*) These palatines are very simple; they give off from their main bar merely a scooped lamina, growing towards the skull base, becoming the ethmo-palatine in front; and this part articulates with a splint of the trabecular arch, the small styliform vomer (*v.*), which is notched behind, bluntly pointed in front, and primarily arygous.

The pterygoids (*pg.*) are stout little bony mallets, with a pad, as if of leather—the cartilaginous articular meniscus. Where each bone glides on the similarly padded trabecular region these facets look upwards and inwards. The end of the palatine is articulated by strong fibres to a sinuous notch on the fore-end of the pterygoid. This notch is bounded by the basi-ptyerygoid facet below, and by a stunted "meso-ptyerygoid process" above, which rides over the palatine. It is arrested in the *Gallinacea*, and never becomes segmented off (see below). The hinder end of the pterygoid is scooped below to articulate with the counterpart knob on the front face of the quadrata. A joint cavity is formed here. Above that joint, and looking upwards and forwards, is a very stunted "epi-ptyerygoid" process, which clings to, and is strongly strapped upon, the quadrata by fibrous tissue.

<sup>1</sup> See *Phil. Trans.* 1866, plate 7, fig. 4, *a.p.*; and *ibid.*, 1874, plate 34, fig. 2, *a.p.*

The large quadrate bone (figs. 13 and 15, *q*.) has its free pedicle or orbital process still soft above. Its otic

these are the frontals (*f*.), which form the upper crescent of the large circle of the eye. They flatten in front, where

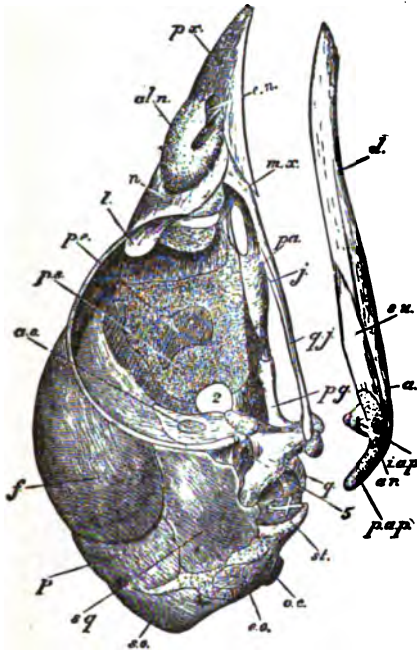

FIG. 15.—Same skull, side view,  $\times 3$  diameters. Letters as above, with the addition of—*p*, parietal; *d*, dentary; *m.x.*, maxillary; *a*, angular; *p.a.p.*, posterior angular process; *i.a.p.*, internal angular process; *a.r.*, articular.

process has a larger rounded head for the squamosal (*sq.*), and a lesser rounded head for the prootic within. In front of the otic process is a sort of trochanter or spur. Below, the articular facet is somewhat divided, by a shallow fossa, into an outer larger and an inner lesser facet. The otic process passes through the front of the tympanic cavity (first cleft), and becomes involved in the membrane thereto attached, namely, the membrana tympani. It was mistaken by anatomists of the last generation for the true tympanic bone. Behind this bone (see fig. 13) there are seen two holes, the inner of them leads to the auditory fenestrae (ovalis and rotunda), and the outer is the opening into a gallery which communicates, by means of diploë, with one on the other side. These are the "upper tympanic recesses," and have their counterparts in the Crocodyla. Besides the pterygoid and palatine, in that part of the mandibular arch which is folded over the mouth, —for the first post-oral enfolds itself to make all the lower and much of the upper jaw,—there are in the outer part of the maxillo-palatine process three bones formed on each side, as we have seen.

The first of these is the bony *ichthyic* maxillary (*m.x.*), with a bony foot, that grows inwards and backwards in a falcate manner, to articulate with the sides of the fore-end of the vomer. These are the maxillo-palatine processes (*m.x.p.*) Behind the maxillary, overlapping its jugal process, is the styloid jugal (*j.*); and behind this, and overlapping it, the quadrato-jugal, which is hooked to fit in the side of the base of the quadrate behind (*q.j.*, *q.*) There is a small joint cavity at this place.

The side view (fig. 15) illustrates the above description; but it also shows much that is not visible below. The section (fig. 16) helps us still further.

The roofing bones are now well seen; the largest of

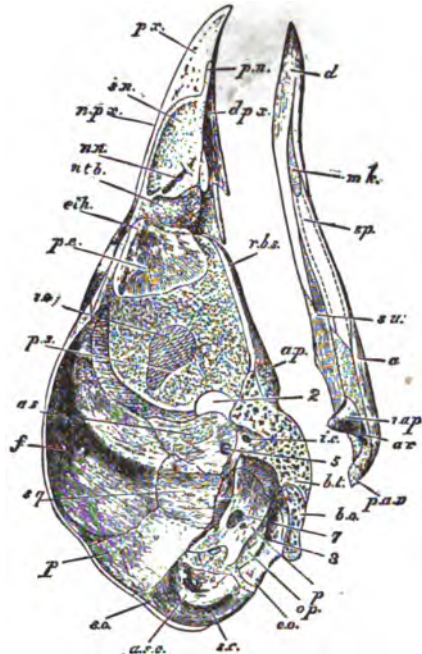

FIG. 16.—Longitudinally vertical section of the same skull, showing axial parts, cranial cavity, and inner view of mandible,  $\times 3$  diameters. *co.f.*, inter-orbital space, or "fenestra;" *a.p.*, anterior pterygoid process, or "basal-ptyergoid;" *op.*, opisthotic; *a.a.c.*, anterior semicircular canal; *a.c.*, stapes canal; *sp.*, sphenoid bone. The small bony centre between the prootic (*pr.o.*) and the super-occipital (*s.o.*) is the epiotic.

they are overlapped by the nasals and nasal processes of the premaxillaries (*n.p.x.*)—a peculiarly ornithic character amongst the higher vertebrata. The orbital rim is very neat and perfect; the main part of the bone, covering the *hemiptere*, is a convex radiating scale. Inside the orbit the bone sends inwards a thin scooped orbital process (*f*.), on whose convex surface the sloping brain resta. This fails to invest the fontanelle, and the orbito-sphenoids, as yet, are not. The somewhat oblong and also convex parietals (*p.*) stop up the gap as far as to the occipital arch; they are much smaller than the frontals. Both the parietals and frontals are flanked and in some degree overlapped by the squamosals (*sq.*), which are more irregular in shape than, but are fully as large as, the parietals. Half the inner face is seen within (fig. 16, *sq.*); the whole upper edge behind is hidden in this view, and much of the lower part, which forms a strong eave over the huge ear-mass. The lower edge has a cup for the quadrate main head. On the outside (fig. 15) there is to be noticed a variable cartilaginous tract; it takes in all the elegant crescentic tympanic wing of the exoccipitals (*e.o.*), and also runs in front of and between the ex- and super-occipitals (*s.o.*, *s.o.*) Between the two bones is the posterior opisthotic region; in front of the exoccipital is the epiotic region. From the inside the imbrication of the cranial and auditory bones is seen to be very regular and remarkable. Running round and across, behind and below the posterior margin of the frontal, we see the fenestrae alisphenoid (*a.s.*) underkirting the orbital plate of the frontal, then the hollowed inner face of the squamosal, and behind and above that the scooping of the parietal. Below the same, and also behind it, we have—above, two bones, the prootic in front

and the super-occipital behind. But the latter takes in all the breadth behind, whilst below the prootic are two, the upper the smaller; the lesser bone is the opisthotic, the larger, rounding the foramen magnum at its sides, is the exoccipital (*op.*, *e.o.*) These are infero-lateral elements. Below the whole are the basi-sphenoid and the basi-occipital, both of them underfloored by the basi-temporal (*b.o.*, *b.t.*) So much tilted backwards is the auditory mass that the crown of the anterior canal (*a.s.c.*) is imbedded in the super-occipital. In a Lizard, Snake, or Turtle that part would be first enclosed in a separate epiotic bone, which would be soon confluent with the super-occipital. But in these high *Sauropsida* the epiotic is a small, *late* centre, formed behind the commencement of the anterior canal in the front part of the recess in which the "focculus" lies. Also the opisthotic is small, but is distinct for three or four months; it is a wedge of bone, flat-faced within, forming a straight suture with the hind edge of the prootic, and externally runs as a fine thread of bone between the two fenestrae of the labyrinth. We do not see this bone behind until afterwards, and it soon coalesces with the exoccipital, first with it and afterwards with the prootic, as in Lizards and Snakes.<sup>1</sup> After the elements of the chondrifying cranium have run into each other, the enclosed ear organs, by their copious growth, and also by their having many diverticula, such as the cochlea and canals, trespass on neighbouring territories, so that whilst the cochlea burrow into the parachordal region, the semi-circular canals find room in the occipital arch.

In the Osseous Fish ("Salmon's Skull," *Phil. Trans.*, 1873, plate 5, fig. 8, *sp.a.*) there is a large bone called the "post-frontal" by Cuvier; in the Bird it often occurs, and looks like a secondary wing on the great sphenoidal wing (alsisphenoid). In the Fish it covers the ampulla of the anterior canal; in the Bird it is in front of it and of the whole labyrinth. This bone, the "sphenotic," is ossified at the time of hatching.

The anterior sphenoidal region is all soft as yet (figs. 15 and 16, *p.a.*); and the great mesethmoidal wall (*p.e.*) covers only a third of its own proper territory. It now reaches to the notch; nearly to the roof also, but not to the parasphenoid. The cartilage it is ossifying is continued as an isthmus connecting the parts behind and in front of the notch (cranio-facial hinge). Through this notch (fig. 16, *a.f.*) we see the swollen upper turbinal; and the nasal canal and bridge for the fore-part of the trabecular nerve is seen near the hind margin of the steep and well-formed septum nasi (*a.s.*), which has projecting from it the lessening rostrum (*p.n.*) Bridging over the notch, and let into the fore-edge of the frontal, are the never-coalesced nasal processes of the premaxillaries. Outside these, on each side (never in the middle in a Bird), are the nasals (fig. 15, *n.*) They are curious twisted bones, two-bladed in front to bind round the alisinal cartilages (*al.n.*) and outer nostril (*a.n.*); behind, they twist a little downwards the inner edge of their flat end. Tied by fibres to the side of the narrowed end of the frontal, and to that part of the nasal which is imbedded into it, is the lachrymal (fig. 15, *l.*) Its main part is the super-orbital, and this sends downwards a facial process, narrow and sigmoid. Within the lachrymal is the pars plana (*p.p.*), a subquadrate curtain, which is persistently cartilaginous in the Fowl, whose nasal labyrinth, unlike that of many birds, scarcely ossifies at

<sup>1</sup> The nomenclature of these parts is wrong in Mr Parker's paper on the "Fowl's Skull," *Phil. Trans.*, 1869; but he named their elements correctly in his former paper on the "Struthious Skull," *ibid.*, 1866. Researches into the growth of the Reptilian skull have helped to correct the error. He has found a true "pteric" in the Sparrow-Hawk (*Monisth. Microsc. Jour.*, Feb. 1, 1873); that was the name given by him to the fowl's epiotic, whilst the latter name was applied to the posterior face of the opisthotic.

all, except the main dividing wall, the perpendicular ethmoid, which always early becomes solid.

The free mandibular bars are now continuous at their fore or lower end; the long and strong dentaries (figs. 15 and 16, *d.*) early coalesce. In front they cover the attenuating Meckel's cartilage (*m.k.*); this, however, grows on behind, and its inner process (*i.a.p.*) is ossifying as the "articular," the only endo-skeletal bone in the mandible. Behind, outside, and a little within, we see an upper and a lower splint, the surangular and the angular (*sa.*, *a.*), and on the inner side, further forwards, the oblong splenic (*sp.*); but in this bird there has not been found a "coronoid," common in certain groups of Birds, besides Snakes, Lizards, and Crocodiles. In this and in other things the Fowl is often found wanting as to special elements.

The changes in the hyoid arch can be left until we come to the adult stage.

*Cranium of Fowl—Sixth Stage.*—This stage, which is

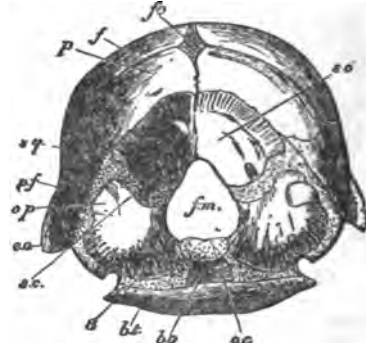

FIG. 17.—End view of skull of a Chickney three weeks old, sixth stage, x 3 diameters. Here the opisthotic bone appears in the occipital region, as in the adult *Chelonia*. Letters as above, *a.c.*, the opening of the sternal canal.

that of chickens less than a month old, is introduced to show the occipital region from behind (fig. 17). This end view shows much that is ornithologically characteristic. The subject was a somewhat starved chicken, whose retardation of growth caused a lingering of the ankylosis, which so soon removes all landmarks. Even now the great fontanelle, or membranous roof of the basin-like chondro-cranium, is barely covered by the still scant frontals and parietals (*f.*, *p.*); their flanking by the big squamosals (*sq.*), and the projection beyond these of the sphenotics, are well shown. A wholly cartilaginous epiotic region is still seen; it runs also inwards to the foramen magnum (*f.m.*), and still skirts the tympanic ala (*e.a.*) But on the upper and outer edge of the exoccipital a small plot is taken from the great exoccipital. This is the appearance through the cartilage of the opisthotic (*op.*); and this represents the permanent condition of the occipital arch in the *Chelonia*, which shows a free posterior face of the opisthotic above and outside the exoccipital. This view also shows how the skull is double-floored by the addition of the basi-temporal slab to the ossifying chondro-cranium (*b.t.*, *b.o.*)

*Cranium of Fowl—Seventh Stage.*—In chickens two months old, a section of the skull shows all the sutures except those lost by early fusion of the three para-sphenoidal elements with the compound basi-sphenoidal ossifying cartilage. The periotic elements are all distinct, not only from each other, but also from their surroundings (*Phil. Trans.* 1869, plate 85, fig. 1.) The bony orbito-nasal wall (perpendicular ethmoid) has grown by metamorphosis of the cartilage up to, and somewhat over and under, the inter-orbital fenestra; thus half of this large septum is bony. There is no osseous presphenoid, but instead of the true orbito-sphenoid two osseous centres have appeared on

the post-orbital fontanelle, the foremost being the smaller bone; these help the orbital plate of the frontal to cover the eyeball with bone. In front of the doubly notched ethmoidal wall the face is connected with the skull by a narrow band of cartilage, which is never quite severed in this type. Thus the fore-face lifts on the skull in harmony with the depression of the mandible, by means of the elasticity of the parts, for, as we have seen, the firm splints above—nasals and nasal processes of the premaxillaries—are let into the frontal by their fibrous, lathy ends.

*Cranium of Fowl—Eighth Stage—Chicks Three Months old.*—Many sutures still remain at this stage, but those between the occipital and petiotic elements are fast filling up (*Phil. Trans.*, 1869, plate 85, figs. 4-7, p. 794). We must refer the reader to the work above cited for the details; no stage shows the exquisite architecture of the ornithic skull more lucidly than this. The synchondroses are reduced to fine lines or sutures, and the *size* of the object is of great importance, as tending to make a difficult study easy to the observer.

*Cranium of Fowl—Ninth Stage.*—In chickens of the first winter, eight or nine months old, nearly full-sized, but yet succulent even in their skeleton, many things are to be observed (*op. cit.*, plates 86, 87, figs. 1-3, p. 795).

On the roof the sagittal suture is only obliterated in the parietal region, and the super-occipital still retains an upper notch. The occipital and auditory regions have entirely coalesced—the opisthotic with the exoccipital first, and then with the prootic; but the little epiotic seems to melt into the common mass of the ankylosing super-occipital and prootic, without any precedence either way. All the sutures across the cranio-facial hinge are still visible, namely, those made by the frontals, lacrymals, nasals, and nasal processes of the premaxillaries, in their relations. Where the frontals diverge by narrowness in front, behind the nasal processes of the premaxillaries, there the ethmoid is seen becoming fast bony from the substance of the perpendicular plate, and not by a separate upper bone, as in the *Struthionidæ*.<sup>1</sup> As to the facial bones, they yet retain much distinctness, and the prenasal and Meckelian rods still linger. The articular end of the latter rod is now ossifying fast, the two angular processes, so large in this type, are now bony. The fast coalescing roof and the coalesced floor are now of great thickness, and the diploë in this type is coarse (*op. cit.*, plate 86, fig. 14). In all these growing stages, tracing bone by bone, as it appears, we have not yet met with the presphenoid, nor seen the behaviour of the great ethmoidal wall in relation to the hinder skull. In the most advanced winter chickens these things are to be seen (fig. 18, *p.a.*, *p.c.*, *b.s.*)

The presphenoidal region is merely that band of cartilage which lies partly above, but mainly behind, the fenestra (*i.o.f.*) A small ossicle has appeared in it close below the second orbito-sphenoid (*p.s.*, *o.s. 2*), the foremost orbito-sphenoid (*o.s. 1*) has coalesced with the perpendicular ethmoid.

From that bone the rostrum of the parasphenoid is still distinct (*r.b.s.*), but the perpendicular plate has now reached the basi-sphenoid (*p.s.*, *b.s.*), and between them, and below the still soft lower part of the presphenoid, there is a high vertical suture. This suture, and this steep bony wall beneath the presphenoid, are of the greatest interest to the morphologist. We saw that the basi-sphenoid was compound, having in it, besides the parasphenoidal elements as investing parts, both the parachordal ends and the trabecular apices. So it is, for the Bird's skull runs over, or rather is built upon, the marvellously metamorphosed *first visceral arch*—the arch formed by the primordial "trabeculæ cranii." Counting from the spine, we have *three* cranial sclerotomes in the osseous stage. The *first* is formed on a notochordal and parachordal foundation; this is the "basi-occipital." The *next* is formed on a foundation partly parachordal and partly facial—the basi-sphenoid. The *third* is the "presphenoid," and it is tilted up over the forth-growing trabecular arch, the elements of which early coalesce at the mid-line, and the common crest of which is not, for a long time, in any way actually separate from the approximating roofs of the nasal saca.

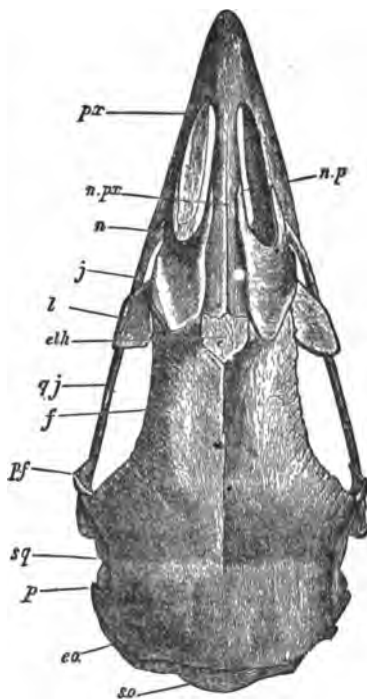

FIG. 19.—Skull of an old Fowl, tenth stage,  $\times 1\frac{1}{2}$  diameters, upper view. Above the line from a. is seen the large two-spurred nasal, the processes of which upper and lower—are marked n.p., the cartilaginous structures of the nose are not figured.

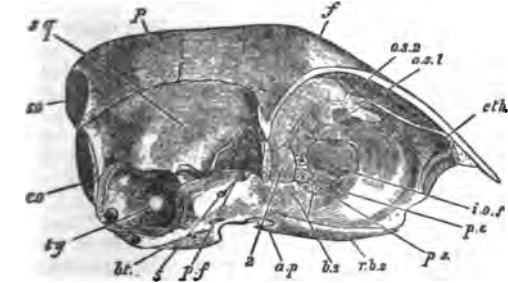

FIG. 18.—Skull of young Fowl of first winter, ninth stage, side view,  $\times 1\frac{1}{2}$  diameters. a.s. 1 and a.s. 2 the two small orbito-sphenoidal centres above the small presphenoid p.a., which is only partially ossified at present. The sutures at this stage are very instructive. The fore-face has been removed, and the anterior edge of the perpendicular ethmoid (p.a.) is the posterior boundary of the cranio-facial cleft.

*Cranium of Fowl—Tenth Stage.*—In old birds we find an intense degree of ankylosis, and yet certain sutures are persistent to old age, or at least show some chink or mark of their original separateness. In this the Fowl agrees with most birds, but, being at no great height above the

<sup>1</sup> *Phil. Trans.*, 1866, plate 8, fig. 10, *eth.*, *p.a.*

*Struthionida*, it is not the strongest example of what a Bird's skull may be. In a bird's-eye view we see the separateness of the nasals, the nasal processes of the premaxillaries, the fore-end of the frontals, the top of the ethmoid, and the lacrymals (fig. 19, *n.px., n., f., eth., l.*) Below (fig. 20), the premaxillaries still have sutures with the palatines and maxillaries, and the latter has its jugal process, the jugal itself, and the quadrato-jugal, all distinct (*px., pa., mx., j., qj.*)

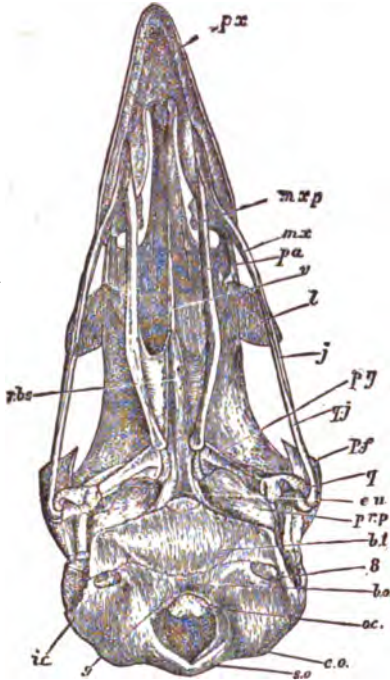

FIG. 20.—The same skull, basal view. Here the slenderness of the upper facial rod is in strong contrast with the massiveness of the skull itself. This skull is unusually *schleppschädel*, the vomer (*v.*) being very small, and the maxillo-palatine processes (*mx.p.*) much aborted.

Moreover, the quadrate (*q.*), pterygoid (*pt.*), the palatines, and of necessity the mandible—all these retain their joints, and traces of the union of the mandibular splints are long retained (fig. 21, *d., ar.*) So also do the elements of the hyoid arch, soon to be described, remain separate.

The whole cranial box, and all the inter-orbital region, have become one bone, whilst the various fontanelles are filled in. In the specimen which has been figured the inter-orbital fenestra (*i.o.f.*) is partly open, but it is often obliterated. Also we see that free periosteal bony growths have bridged over the temporal fossa, the post-frontal or "sphenotic" having met and coalesced with a zygomatic process of the squamosal (*p.f., sq.*) In the lower view we still see the notochordal dimple on the transverse occipital condyle (*o.c.*), and the hinder margin of the basi-temporal plate is still traceable in front of the passages for the vagus and the internal carotid burrows (*i.c.*) This thick bony mass is totally ankylosed to the basi-sphenoidal region above. The prootic and alisphenoidal regions are land-marked below by the foramen ovale (*o.*), which is sometimes, as in Fishes, divided into two by a bony bar. So free is the bony growth that the basi-temporal has coalesced with the temporal wing of the exoccipital (*b.t., e.o.*), and in front of this bridge we see a number of passages, burrows, galleries, windows, &c., leading above to the upper tympanic recess, in front to the anterior tympanic recess, below that to the eustachian opening, and on the middle of

the inner face of the drum cavity a large hole which leads to the two fenestra. The various bones of the palate are

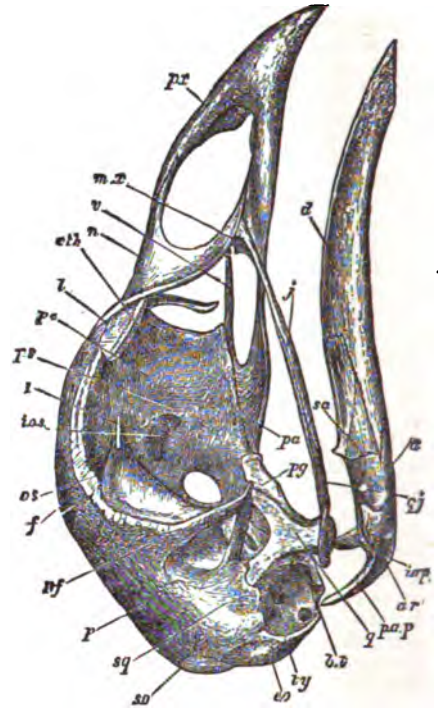

FIG. 21.—The same skull, side view, with the mandible a little dislocated. Here the temporal fossa is bridged over by the junction of the post-frontal and squamosal processes (*p.f., sq.*) The processes of the mandible (*l.e.p., p.a.p.*) are characteristic of this type, and of the *Americæ*.

scarcely in the least changed in form or relative size since the time of hatching (fig. 20), and the copious growths of cartilage belonging to the mesal labyrinth are always soft; these are not figured in the adult skull. There are, however, a few bony centres, the feeble representatives of the ossifications found amongst higher birds in this region. Thus, close in front of the broad wall-top of the ethmoid, in the substance of the septum nasi, there are two small ossicles, and on each side a similar bony point; the rest remained unossified, all save a small part of the attached margin of the pars plana.

The attenuated remains of the second post-oral, and the larger third post-oral arch, contain persistent cartilage. The elegant "columella auris" (fig. 22) is bony where it fits into the fenestra ovalis (*o.f.*), and the shaft, up to its rays (*m.o.f.*), also; but the short, notched supra-stapedial (*s.s.*), the tongue-shaped and fenestrate extra-stapedial (*e.s.*), and the slender, combined infra-stapedial and stylohyal (*i.s.*), all these are still cartilaginous.<sup>1</sup> The rest of the second post-oral is reduced to the arrowhead-shaped lingual bone, the coalesced and partly ossified cerato-hyal (*c.h.*), and an elegant ridged phalangiform basi-hyal (*b.h.*) The free end of the combined glossoal piece is soft. There is no tympanic in the Fowl; only in the Peafowl have we found one, and it is behind the membrana. The next arch, the thyro-hyal (first branchial in *Ichthyopsida*), is composed of two almost equal rods; the upper is only ossified in it

<sup>1</sup> Sometimes, even in the Fowl, the infra-stapedial has a sphenoid stylo-hyal at its free end (see Professor Huxley's figure, *Proc. Zool. Soc.*, May 27 1869, p. 309, fig. 5 B, I. S.)

dial third, and the lower is mainly bony; their basal piece is largely soft behind (fig. 15, *c.br.*, *c.br.*, *b.br.*)

The skull of the Fowl, and of the *Alectoromorpha* generally, differs in certain respects from that of other *Schisognathæ*. In the *Gallinacæ*, as in the desmognathous *Rapacæ*, the vomer is single; in Pigeons and Sand-Grouse it is absent; in all the others with open palates it is composed of two halves soldered more or less together. Some of the *Schisognathæ* possess an "os uncinatum"—as the Albatross and the Gull—a bone to be described hereafter; and others possess a pair of bones attached to the double vomer, namely, the "septo-maxillaries," known in Reptiles as the so-called "inferior turbinata."

These bones, very small in all Birds, have been found by Mr Parker at the top and the bottom, as it were, of the schisognathous series; that is, in the Humming-bird (*Patagona gigas*), and in the Kagu (*Rhinocetus jubatus*).

The latter is a Gruine bird, lying on the margin of the group towards the Night-Herons, whilst the Humming-birds are certainly amongst the most specialized types. All the *Schisognathæ*, except the Fowl tribe, have "meso-ptyergoida." In certain *Schisognathæ* there is an "inferior labial" on the edge of the mandible, namely, in the *Ballidæ* (e.g., *Fulica atra* and *Gallinula chloropus*). These were found by the writer many years ago. Upper labials have not as yet turned up in these types, although they have been figured carefully in the Rhea (*Phil. Trans.*, 1866, plate 10, fig. 14, on each side of *r.h.s.*, close under the inferior turbinal *i.t.*), and the Rhea is a much lower type than the birds under notice. As in the *Gallinacæ*, the *Schisognathæ* generally have little development of the tympanic ring, but in *Egialitis hiaticula* there is one large and three or four lesser bones on each side; they occur in *Numenius arquata*.

A full and adequate idea of the degree of the metamorphosis of a Vertebrate skull attained to in Birds can only be obtained by observation of what is to be seen in that of the higher arboreal types. But some of the *Carinata* are half Struthious, and they possess that low kind of skull which is called "Dromæognathous," best seen in *Dromæus*, the Emeu.<sup>1</sup> This kind of skull once understood, the relation of that of the Fowl to that of types far above and far below it will be clearly seen; for we must describe the Desmo-

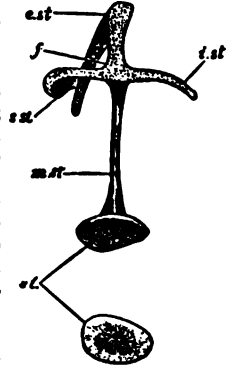

FIG. 21.—Auditory "cotumella" of *Otidea*, ninth stage, X 6 diameters; lateral and basal views. *st.*, stapes; *m.st.*, medio-stapedial bar; *s.st.*, super-stapedial; *e.st.*, extra-stapedial; *i.st.*, infra-stapedial; the end of this latter process is the stylo-hyal, often more dilated than in this specimen; *f.*, fenestra in extra-stapedial plate.

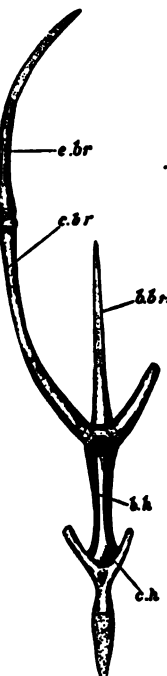

FIG. 22.—"Os hyoides" of adult Fowl, tenth stage, X 14 diameters. *c.h.*, cartilago-hyalis (conduent); *h.h.*, the so-called "basal-hyal," answering to the first basibranchial of a Fish; *b.br.*, basibranchial, oruro-hyal, answering to the rest of the basibranchial series of a Fish; *c.h.*, *c.br.*, the thyro-hyal, answering to the first ceratohyal and epibranchial of a Fish.

gnathous, *Egithognathous*, and *Saurognathous* varieties also.

**The DROMÆOGNATHOUS Type—Cranium of *Tinamus variegatus*.**—Professor Huxley (*Clas. of Birds*, p. 425) says, "The *Dromæognathous* birds are represented by the single genus *Tinamus*, which (as Mr Parker has shown)<sup>2</sup> has a completely struthious palate. In fact, the vomer is very broad, and in front unites with the maxillo-palatine plates, as in *Dromæus*, while behind it receives the posterior extremities of the palatines and anterior ends of the pterygoid bones, which thus are prevented, as in the *Rabbits*, from entering into any extensive articulation with the basi-sphenoidal rostrum. The basi-ptyergoid processes spring from the body of the sphenoid [they are not segmented plates of cartilage attached to the parasphenoid, as in the true *Carinata* (see above)], not from the rostrum, and they articulate with the pterygoid very near the distal or outer ends of the latter bones." In the Fowl, as we have just seen, the fore-end, or main part of the pterygoid, glides on the rostral plate. "The head of the quadrate bone is single, as in the Struthious Birds (Parker, *l.c.*)" To this we may add that the basi-temporals are very feebly developed, as we find from examination of three adult species:—*T. robustus*, *T. variegatus*, and *T. brasiliensis* sive *major*.<sup>3</sup>



FIG. 23.—Skull of *Tinamus variegatus*, adult, palatal view, X 2 diameters. The greater part of the jugal bar and the quadrate bones have been removed. *r.h.s.*, fore-end of parasphenoidal rostrum; *a.p.*, anterior pterygoid process (basi-ptyergoid).

If Professor Huxley's description be compared with the accompanying figure (24) of the Tinamine skull this variety will be easily understood; the lettering is the same as in the figures of the Fowl's skull. For further details the reader is referred to Mr Parker's *Memoirs* above referred to, especially that on the Struthious types (*Phil. Trans.* 1866, plates 7-15).

**THE DESMOGNATHOUS Type of Skull.**—This kind of skull occurs in such a variety of families that, notwithstanding its importance to the morphologist, it is not of so great a value to the zoologist. Nor indeed is it quite equal to some of the groups in value, being due to a

<sup>1</sup> A note is given below as follows:—"On the Osteology of Gallinaceous Birds and *Tinamus* (*Transactions of the Zoological Society*, vol. v. 1864). Sundevall, however, had already said of *Tinamus*, *Rhinocetus*, and *Cryptopus*, 'Struthionæ parvos referunt.' The last two are merely sub-genera of *Tinamus*.

<sup>2</sup> The writer hopes to show the development of this type of skull at some future time; an embryo of *Rhinocetus rufescens* is treasured up for this purpose.

<sup>1</sup> *Phil. Trans.*, 1866, plates 11-18.

condition arising rather from an excess of osseous deposits than from any very striking metamorphosis of primordial elements. The skull of the *Schisognathus* easily runs, as it were, into this type; whilst it crops up among such simple palates as those of the Fowl tribe, namely, in *Cras globicera*; and *Talegalla Lathamii* in old age is nearly desmognathous. So also on the Ardeine borders of the *Gruidæ*, the Kagu (*Rhinocetus jubatus*),<sup>1</sup> is almost a Night-Heron, and nearly desmognathous. In another region *Nyctibius* almost comes across to the gigantic Goatsuckers (*Podiceps*) and the Oil-bird (*Steatornis*). (See Huxley, *Clas. of Birds*, p. 456.) In the paper just referred to (p. 453) the *Desmognathus* are thus described:—"Those Cuvierian *Grallæ* and *Natatores* which are not schisognathous, the *Accipitres* or *Raptores*, the *Scansores* [excluding the *Picidæ*], and among the *Passeres*, most of the *Fisirostres*, all the *Syndactylis*, and *Upupa*, may be termed desmognathous. In these birds the vomer is often abortive, or so small that it disappears from the skeleton. When it exists it is always slender, and tapers to a point anteriorly. The maxillo-palatines are united across the middle line, either directly or by intermediation of ossifications in the nasal septum. The posterior ends of the palatines and anterior ends of the pterygoids articulate directly with the rostrum, as in the preceding division" [*the Schisognathæ*].

It is possible to make several important divisions in the kind and degree of desmognathism, as follows, namely—

a. *Direct*.—In Falcons and Geese, the maxillo-palatines meet below at the mid-line, as in the Mammal. Two sub-varieties of this form occur, as in the Falcon, where the nasal septum is ankylosed to this hard palate, and in the Goose, where it remains free.

b. *Indirect*.—This is very common, and is best seen in Eagles, Vultures, and Owls. The maxillo-palatines are ankylosed to the nasal septum, but are separated from each other by a chink.

c. *Imperfectly direct*.—This is where the maxillo-palatine plates are united by harmony-suture and not by coalescence. Example—*Dicholophus cristatus*. In young Falcons and Hawks the palate is at first indirect, is then imperfectly direct, and at last perfectly direct.

d. *Imperfectly indirect*.—Here the maxillo-palatines are closely articulated with, and separated by, the "median septo-maxillary," but there is no ankylosis. Example—*Megalama asiatica*.

e. *Double Desmognathism*.—This is seen in *Podiceps*, where the palatines as well as the maxillaries largely coalesce below; to a less extent this is seen also in the larger Hornbills (*Buceros*). (Huxley, *op. cit.*, pp. 445, 446, figs. 27, 28.)

f. Lastly, a compound form, in which the sagittognathous skull becomes desmognathous, is seen in certain *Coracomorpha* (*Gymnorhina*, &c.), as will be shown below.

Professor Huxley's remark, that the vomer, "when it exists, is always slender, and tapers to a point anteriorly" (p. 435), is modified by a note he gives on the same page with regard to the broad emarginate vomer of *Falco*. It has a similar, but not equal, enlargement in front in the Sacred Ibis (*Thresciornis aethiopicus*), and the knife-shaped vomer of the Duck tribe is often thick at the infero-anterior angle, as may be seen in *Eidemia nigra*, *Querquedula caudacuta*, and *Mareca penelope*, but the vomer of the *Chenomorpha* is compound, and the antero-superior bone, whose lower angle in part is enlarged, is the median septo-maxillary: this may be seen in young Geese, and in the adult Crested Screamer (*Chauna chavaria*).

Here it will be necessary, in order to show the value of these types of skull, to insert Professor Huxley's masterly

handling of the modifications of the *desmognathous* skull, and the groups in which it is present. It is open to us, however, to modify some statements of his and to superadd others, for the observation of which the present writer has had much greater leisure, and the advantage of having dwelt long on the subject.

At page 460 (*op. cit.*) we read: "Not fewer than seven groups of families appear to me to be clearly distinguishable in this subdivision, viz., the *Chenomorpha*, the *Amphimorpha*, the *Pelargomorpha*, the *Dysporomorpha*, the *Actomorpha*, the *Petitacomorpha*, and the *Coccygomorpha*."

1. The *Chenomorpha*.—"The lachrymal region is remarkably long [save in the Screamer (*Chauna*)]. The basi-sphenoidal rostrum has oval, sessile, basi-ptyergoid facets, like those of the *Alectoromorpha*. The flat and lamellar maxillo-palatines unite and form a bridge across the palate." Yet each of these plates has a large obliquely-ascending process; and the vomer lies on the groove formed by the union of the maxillo-palatines; the more or less ossified septum, in old age, coalesces, by its outstanding processes, with these plates. The internal, but especially also the posterior angle of the mandible is largely developed, and so also is the transpalatine angle of the palatine. The gloss-hyal is very large and spatulate, and the thyro-hyals are flat and broad where the two unite. A remarkable structure is found in Ducks and Swans, namely, an ossicle on each side between the palatines, and stretching towards the maxillo-palatine plate: these bones are the "inter-palatines;" they tend to carry on the hard palate.

2. The *Amphimorpha*.—"The genus *Phamiscopterus* is so completely intermediate between the Anserine birds on the one side and the Storks and Herons on the other, that it can be ranged with neither of these groups, but must stand as the type of a division by itself. Thus the skull has the long lachrymo-nasal region, the basi-ptyergoid facets [not so; see *op. cit.*, p. 437, where they are truly said to be rudimentary—they are the merest prickles], the prolonged and recurved angles of the mandibles, the laminated horny-sheath of the *Chenomorpha*; but the maxillo-palatines are spongy [scarcely more so than in the Swan *et hoc genus omnes* of the Anserine and Anatine], and the general structure of the rostrum is quite similar to that found in the Storks and Herons." The nasals are thoroughly Anserine, having their crura separated by a rounded notch; their palatines are quite Anserine, but are broader behind, being exactly like those of the Screamer; and yet they cut off the meso-ptyergoid, which coalesces with the palatine. This the Storks and their allies do; the *Chenomorpha* do not. The pterygoids are like those of *Thresciornis* and *Platalea*, but the vomer is intermediate between that of the Goose and the Spoonbill. The orbital processes of the palatines, or "ethmo-palatines," run together as arched laminae from the body of the bone to the maxillo-palatine floor. They are very shell-like at first, and are attenuated in front. They coalesce together, and send down a bony keel of exquisite thinness in their hinder part. There is a part separate from the rest in front, just where they begin to narrow; this is obviously the median septo-maxillary. Behind, where the palatines shoot below the rostrum of the sphenoid, each bone sends down a lamella; each of these is bound to its fellow by fibrous tissue, and between these the vomer is wedged; the thin plate belongs mutually to the palatines and the zygous vomer. In all the ordinary *Chenomorpha* the ethmo-palatine spurs are long; in *Phamiscopterus* enormously so; in the Screamer they are very short. Hence the palato-vomerine structures of the *Amphimorpha* are Anserine, but much modified. So also in the hyoid apparatus; and the huge glosso-hyal is, although cartilaginous, the true counterpart of that of a Swan.

<sup>1</sup> See *Trans. Zool. Soc.*, vol. vi. plates 91 and 92.



3. The *Pelagomorphæ*.—"There are no basi-ptyergoid processes, and the palatines usually unite for a greater or less distance behind the posterior nares; but they send down no vertical plate from their junction." In the *Ardeidæ* they do not unite; in all these forms the coalesced part is short as compared with that of the Cormorants and Pelicans; in both *Scopus* and *Balaniceps* the ankylosed part is carinate below (*Trans. Zool. Soc.*, vol. iv. plate 65, fig. 1, *pal.*) "The maxillo-palatines are large and spongy. The angle of the mandible is truncated," except in *Platalea* and *Ibis*. The vomer is smallish and cultrate in *Ciconia nigra*; larger by far, cultrate, and pedate at the end in *Thresciornis cithiopiensis*; as large in *Platalea leucorodia*, but pointed in front and carinate below. Even in the last of these forms, in a half-grown individual, no sign of a median suture was seen. The vomer of *Scopus* is sharply cultrate above and rounded below; it reaches beyond the maxillo-palatine mass. In *Balaniceps* (*op. cit.*, p. 308, plate 65, fig. 1, *v.*) the vomer is like that of *Scopus* and *Ciconia*, but it is actually smaller than either. In most of these Ciconian and Ibtidine types<sup>1</sup> the vomer is evidently azygous, but in all the skulls of *Ardeidæ* now before the writer, viz. one or two species of each of the following genera, *Ardea*, *Botaurus*, *Nycticorax*, *Garsetta*, *Tigrisoma*, the vomer is double, large, and charadrian.

In *Ardea cinerea* the vomer is coalesced behind with the long, elegant, bicarinate palatines, and in front runs its point in between the free retral lobes of the maxillo-palatines. The moieties have each a rounded keel, and those keels run parallel at first and then run into each other in front; above, the two halves form a deep fossa, in which the sub-carinate parasphenoid glides. The edges of this trough are roughly tuberculated and turned over, like the rim of a cup; the primary suture between the halves is retained behind for half the length of the bone. In several *Ardeidæ* an additional maxillary bone—the "post-maxillary"—is formed behind the angle of the maxillary. It is small in *Ardea garsetta* and *Botaurus stellaris*, and of good size in *Botaurus viridis* and *Nycticorax ardeola*. This bone was first found by Mr Parker in the Emeu. In *Tigrisoma leucolophum* there is a pair of "inter-palatines," as in the Duck tribe. In the *Pelagomorphæ* the charadrian type reaches its culmination; yet the most exquisite forms, such as the Egrets and smaller Bitterns, and the most gigantic, as the Adjutant, are evidently specializations of a type similar to the pluvialine *Schisognatha*.

4. The *Dysporomorphæ*.<sup>2</sup>—"The rostrum is long and pointed, and more or less curved; and the external nasal apertures are very small. There are no basi-ptyergoid processes. The palate bones unite for a considerable distance behind the posterior nares, and send down a vertical crest at their junction. The maxillo-palatines are large and spongy. The angle of the mandible is truncated."

The inferior crest of the combined palatines is largest in *Pelecanus*, above, in *Phalacrocorax* and *Sula*, this plate is grooved for the sphenoidal rostrum, but in the Pelican there arises a huge crest, and the rostrum of the sphenoid rises rapidly out of its way. Here the secondary palatine arch has the same *habitus* as the primary trabecular arch—a modification constant in birds in the latter. All the parts in front of the very mobile cranio-facial hinge are molten together into one mass, and the nasal labyrinth is in its most aborted state.

In *Phalacrocorax* the perpendicular ethmoid is of small antero-posterior extent. There is no presphenoid, but merely a small V-shaped orbito-sphenoidal band of bone

above the optic passage. The same structure is seen in *Himantopus* and *Eurypyga*. In the Cormorant an oblong ossicle lies on the commencement of the sygoma. It is large in *P. carbo*, and small in *P. graculus*. A still larger ossicle has heightened the sygoma in *Sula alba*. This is the "post-maxillary." In *Sula alba* the basi-temporals are as little developed as in the *Dromaïdæ*, less than in any other Carinate bird. Behind each moiety there is a large oval opening, not far in front of the occipital condyle; this exposes the loose diploë within. The small eustachian tubes open at a little distance from each other, in a wide shallow fossa, on the part where the three elements of the parasphenoid meet. In both the Pelican and the Cormorant there is an elegant, crescentic, lipped, free margin to the very Ardeine basi-temporal plate. In *Sula alba* the columella auris is very long and bent. It has a small cartilaginous extra-supra-stapedial process, and a long attenuated cartilaginous infra-stapedial, terminated by a bony fusiform stylo-hyal. The hinge for the mandible is very far back in *Sula*, whose cranio-facial hinge almost rivals that of the Parrot and Toucan. In the Cormorant the mandibular articulation is almost carried as far back as in the Crocodyla. In *Sula alba* the sygoma is very thick in front, and is suddenly reduced to an extremely thin bar, where it passes into the upper beak.

5. The *Actomorphæ*.—"The rostrum is more or less arched and hooked at the tip. Basi-ptyergoid processes may be present or absent. The maxillo-palatine processes may be concavo-convex lamellæ, or may be spongy and fill up the base of the rostrum; but they are always [except in *Dicholophus*, a genus which the writer adds to the group] united with an ossification of the septum. The breadth of the articular surface at the distal end of the quadrate bone is greater than its length, the outer condyle extending about as far downwards as the inner." This is best seen in the Cariama (*Dicholophus*), and in the Owls, Hawks, and Falcons; in the larger Old World Vultures (*e.g.*, *Gyps fulvus*) it is not so well seen. "The angle of the mandible is never recurved." At pp. 441 and 442 *op. cit.* it is stated that "the maxillo-palatines unite with one another and with the extremity of an ossified septum, so as to fill up the maxillo-palatine valley." In the carefully prepared specimens before the writer, it is found that there is a space between the right and left maxillo-palatine, not only in the *Cathartidæ*, where it is evident, but also in *Gypogeraus*, where it is least. Intermediate between these types come the Old World Vultures and the Eagles. The skulls at hand give the following results, viz. —

a. Perfect indirect Desmognathism.

*Sarcorhamphus papa*, *Aquila* (sp. pl., including *Helotarus scudatus*), *Gyps fulvus*, *Neophron percnopterus*, *Asio otus*, *Asio accipitrinus*, *Asio flammeus*, *Ketupa ceylonica*, *Aluco noctua*, *Sitta stricklandi*, *Hlanus carolinus*.

b. Imperfect direct Desmognathism.

*Dicholophus cristatus*.

c. Perfect direct Desmognathism.

*Falco peregrinus*, *Falco tinnunculus*, *Falco anatum*, *Accipiter virens*, *Buteo vulgaris*, *Circus cyaneus*, *Haliastur indus*.

With regard to the basi-ptyergoid processes, they are most aborted in *Dicholophus*, *Helotarus*, and *Gyps*. They reappear as aborted prickles or knobs in some Eagles, in *Neophron*, *Hlanus*, *Circus*, and *Accipiter*, and in the young of these they are rather large. In *Haliastur indus* they are large, rounded flaps, with no cartilage on their end. Then come *Gypogeraus*, the *Cathartidæ*, and the Owls, in which they are constant. In all the Owls, as in Pigeons and some of the *Turnicidæ* (see *Trans. Zool. Soc.*, vol. 7. plate 34, fig. 2, *m.o.f.*), the slow growth of the occipital region of the chondro-cranium leaves a membranous space over the foramen magnum. This is not, or is very rarely

<sup>1</sup> *Balaniceps* has the head of a Stork, but its body is largely Ardeine.

<sup>2</sup> *Dysporus* a generic name applied to the Gannets by Illiger.

filled up by even the bony growths; it remains as the "median occipital fontanelle."

The vomer in this group is of great interest, being extremely variable, and often having a supplementary bone attached. It is asygous. The palatines also, which have rounded posterior angles and double keels, often have a medio-palatine where they unite, and also receive the meso-pterygoid spur. In some types, as *Gyps fulvus*, the large rounded palatine flap is partly severed off as a "transpalatine." Where the ascending laminae of the palatines meet below the sphenoidal rostrum, there a bony deposit takes place; this, if truly asygous, is a medio-palatine; if oblique, it is one of the meso-pterygoids, which, in the *Rapaces*, get between the palatines, coalesce with each other, and form a keystone, as in *Uula stridula*. In others, as the young of *Falco tinnunculus* and the adult *Helotarsus ecaudatus*, there is one small, obliquely-placed ossicle in the front of the palatine suture. In *Neophron percnopterus* there is one free meso-pterygoid attached to the right hinder fork of the vomer. In *Dicholophus cristatus* there is a large medio-palatine wedged in in front, and to it the cultrate, fenestrated, and pedate vomer is attached. In the Falcons the vomer is pedate, and, in the larger kinds, fenestrated. In *Uula stridula* there is a small vomer attached to a small medio-palatine, and having over it an equally small median septo-maxillary. The latter bone is large in *Asio otus*, and small in *Neophron percnopterus*, *Circus cyaneus*, and *Haliaeetus indus*. The vomer is most aborted in the Eagles and Vultures (often absent); but it is long in *Neophron*. We have found a small bony wedge (oblique meso-pterygoid) in *Scorcorhamphus papa*. Professor Huxley's figure of the skull of *Gypogercanus* is deficient in not showing a small vomer (fig. 24, p. 442). A specimen sent to him by the writer (after the paper appeared) has this little bone distinct. The frowning brow is obtained in these birds by a huge super-orbital process of the lachrymal in *Dicholophus*, *Gyps*, and *Falco*. In many kinds (Hawks, &c.) there is a distinct super-orbital at its extremity. The eyeball, with its massive bony rim, is quite equal in *Dicholophus* to that of the diurnal *Rapaces* generally. Its hyoid also is thoroughly Raptorial. Its glossal (double) piece is spatulate, and, like that of its congeners, approaches the glosso-hyal of the Parrots in breadth. Unlike its congeners, the Carriama has its nasal septum but little ossified; and it possesses an "os uncinatum," propping up the pars plana, as in the Gull, Albatross, and many other birds.

A description of the palate of the Sparrow-Hawk (*Accipiter nisus*), will illustrate that of Raptorial birds generally, and also the meaning of the term *demognathous*.<sup>1</sup> The specimen figured (fig. 25) was a half-developed nestling. Its round occipital condyle, and the various foramina (8, 9), are shown in the occipital region, and outside and above this arch are seen the hinder face of the opisthotic (*op.*), and in front of the tympanic ala of the exoccipital (*ex.*) there is an uncinete bone in relation with the prootic, opisthotic, squamosal, and exoccipital, where they all meet together. This is the "pterotic" (*pto.*), a huge bone in Osseous Fishes, and walling-in much of the labyrinth. In Serpents only a film of ectosteal bone represents it, and in Lizards such a plate appears, overlapping cartilage which has begun to calcify. It develops and becomes part of the parotic process. The basi-temporal plate (*b.t.*), the rostrum, with its arrested basi-pterygoids (*b.pg.*), are shown, and on each side the double condyle of the quadrate (*q.*), characteristically placed transversely. The zygoma is composed of thin needles of bone (*z.f.*, *f.*); the

zygomatic process of the maxillary is, behind, bound up with the jugal and quadrato-jugal, and in front passes into the upper dentary region, half overlapped by the

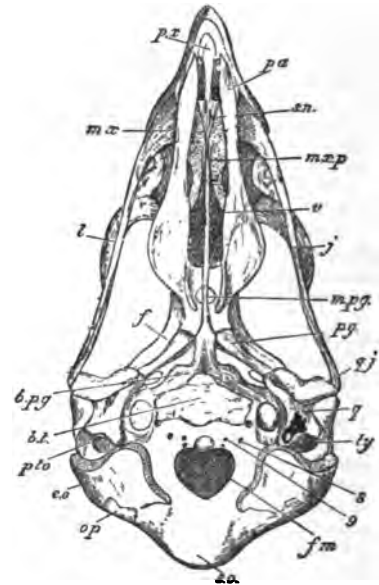

FIG. 25. Skull of nestling Sparrow-Hawk (*Accipiter nisus*), palatal view, X 3 diameters. The circular space on each side of the basi-temporal (*b.t.*) is the opening of the anterior tympanic recess. The meso-pterygoids (*m.p.g.*) show part of their lower face on the post-palatine region; the basi-pterygoids (*b.p.g.*) are mere knobs, and the common ectosteal opening is seen between them. The maxillo-palatine plates (*m.x.p.*) are dotted to show their spongy character.

dentary process of the premaxillary (*px.*) The dentary edge of the maxillary sends inwards the maxillo-palatine plate (*m.x.p.*), which meets its fellow at the mid-line, and also grows retrally and superiorly into an elegant shell-like mass.

The right and left plates lie edge to edge, as in the adult Carriama, and are imperfectly direct in their demognathism. The palatine processes of the premaxillaries bind the fore-ends of the palatines, which in turn bind under the maxillo-palatine plates. The gap in front is filled with the fast ossifying septum nasi; it is pedate in front, and behind sends out a process on each side; these spurs ankylose afterwards with the maxillo-palatine plates, and they with each other. The palatine bones (*pa.*), strap-like, widen backwards, and then gently narrow to the end, leaving no sharp postero-external angle. The wedge of bone which has been fretted off from the fore-end of each of the rod-like pterygoids (*pt.*) binds on the postero-superior edge of each palatine, and the inner plate of these bones covering the under surface of the sphenoidal rostrum imperfectly, allows part of these bony wedges—the "meso-pterygoids" (*m.p.g.*)—to be seen from below. The bird has all the *periotic* bony centres, viz., five, as in Osseous Fishes; it has distinct cartilaginous orbital alae, which are, like the presphenoid, separately ossified, besides an asygous ossification in membrane belonging to the same category.

6. The *Perritacormorpha*.—The uniformity of this group of *Demognathous* is as remarkable as the variability of the last, and yet it is potent in genera and species. "The rostrum (see *op. cit.*, p. 465) is arched and hooked at the extremity, and is regularly articulated with the frontal region of the skull." Therefore we find that the cranio-facial cleft is complete—a state of things not often occurring. The development of this type has not been observed, yet we can interpret the metamorphic results by other

<sup>1</sup> See *Monthly Microscopical Journal*, Feb. 7, 1873, p. 45, plate 5, fig. 2. A paper by the same writer in the *Linnean Transactions*, 1875, may be consulted for copious illustrations of the *Demognathous*,

types. "Basi-ptyergoid processes [and vomers] are wanting. The palatines are vertically elongated posteriorly, while anteriorly they are horizontally flattened, and movably united with the rostrum. The maxillo-palatines are spongy. The lachrymal and post-orbital bend towards one another, and frequently unite below the orbit." This is by the intervention of a large "os uncinatum," which is best seen in small types, such as *Psephotis multicolor*, and *Agapornis pullaria*, where this part does not unite with the post-frontal. In *Microglossa*, *Calyptorhynchus*, *Ptycolophus*, *Melospittacus*, &c., the temporal fossa is also bridged over by junction of the zygomatic process of the squamosal with the os uncinatum. "The orbital process of the quadrate bone is very small, and its distal presents only one facet (which is compressed from side to side, and convex from before backwards) for the mandible. The rami of the latter are deep, and pass into one another by a rounded symphysis." The glosso-hyal is spatulate, and the basi-hyal is alate behind. In the fore-face are some things worth noting. The septum nasi is a thick wall of bone; the alae nasi are soft in *Psephotis multicolor*; they have an annular ossicle found in them in *Melospittacus undulatus*; whilst in *Palaeornis torquata* this part is largely ossified and ankylosed to the upper jaw, and the alinasal turbinal is partly calcified. In one small kind we saw the trace of a small medio-palatine. The pars plana is narrow and ossified, and is ankylosed to the lachrymal; the inferior turbinal is soft.

7. The *Coccygomorpha*.—This is another polymorphic group, and is not in any sense, either zoologically or morphologically, the equivalent of the last. Yet it is almost impossible to separate the families by any character of importance. If the *Podargus* must be linked with the Kingfisher, the Goatsucker and its allies cannot be removed, notwithstanding their *schisognathous* palate. Here, however, we are dealing with the *desmognathous* forms. Professor Huxley makes four sub-groups, and then remarks (p. 467): "It appears to me not improbable that it may hereafter be desirable to divide this group into four." The characters of the skull are thus given (p. 466): "The rostrum presents very various forms, and may be movably articulated with the skull. Basi-ptyergoid processes are present in only one genus (*Trogon*)."

The Oil-bird (*Scolecornis caripensis*) has very large basi-ptyergoids, thus connecting the Goatsuckers with *Podargus*. "The maxillo-palatines are usually more or less spongy. The palatines are not developed into vertical plates, but are, as usual, horizontally flattened. The distal end of the quadrate has the ordinary form." The vomer is small in Hornbills, Toucans, and *Scythrops*; but they have a second bone in front of the arygous vomer, viz., the "median septo-maxillary," as in the Goose tribe and others. In *Podargus*, when the lower palatine floor—like that of a Mammal—is cut away, there are to be seen three small ossicles; the first of these is the vomer, the others are medio-palatines. In *Megalomma* the vomer is very large and forked in front. In the Kingfishers and Hoopoes there is no vomer; there is a trace in *Corythæis*. The palatines may be rounded behind as in *Oculinus* and *Euceros*, have a retral spur to the transpalatine part as in *Ithamphastus Alcedo*, and *Upupa*, or be very broad, with a large *passerine* transpalatine angle, as in *Podargus*.<sup>1</sup>

<sup>1</sup> For a figure of this skull, see Professor Reinhardt's paper on the "Os uncinatum" ("Om en hidtil ukjendt Knogle i Hovedhalen hos Turakoerne *Mucophagides*, Sundev." *Savitsky af Videnskabselige Meddelelser fra den Naturhistoriske Forening i Kjöbenhavn*, 1871). In this paper figures are given of the skull of *Corythæis*, *Mucophaga*, *Scolecornis*, and *Trogon*.

<sup>2</sup> See Professor Huxley's figures, those of M. Reinhardt just referred to, and Dr Murie's valuable papers "On the Skeleton of *Todus*," *Proc. Zool. Soc.*, May 31, 1872, plate 55, pp. 603-630; "On the

*The AGITHOGNATHOUS Type—Cranium of the Rook.*—This figure and its description must do duty for the whole of the *Agithognathæ*, which, with a little cutting and contriving, may be made to cover the *Coracomorphæ* entirely, with enough at its corners also to be superimposed upon the Swifts and the Hemipods, and that remarkable charadriian bird, *Thinocorus*.<sup>3</sup> It is worth while to remember that these types are actually the highest, the most metamorphosed, and the most specialized; not so high in some respects as the Mammal, yet no Mammal comes near them in adaptive modification, not even the one which has the taste to admire, and the wit to describe them. We learn from no less an authority than Mr G. R. Gray that of the 10,000 known birds half belong to this group; the Old World type of which, more especially, are such accomplished creatures. The *Nectarinia* is the smallest, and the Raven the largest of this huge, but morphologically very uniform, group.

The skull of a fledgling Rook (fig 26) illustrates the highest bird of this type; the

occipital condyle (o.c.) is hemispherical, the basi-temporal plate (b.t.) is an almost transverse band of bone, the rostrum of the parasphenoid (p.a.s.) is without any developed basi-ptyergoids, the cranio-facial hinge is nearly perfect, but the nasals and nasal processes of the premaxillaries are thin splints set into the frontals; they do not form a perfect hinge.

The palatines are developed into cartilage at their hinder angle; this is a large flap, and, ossifying late and separately, has time to become chondrified first (t.pa.); the pterygoids (pg.) are phalangiform, and lose their meso-ptyergoid spur, which soon coalesces with the palatines. The maxillo-palatine processes are hooked and flattened, and often enlarged at their inner extremity, so as to become pneumatic.

But the distinguishing character of the type is the *unson*

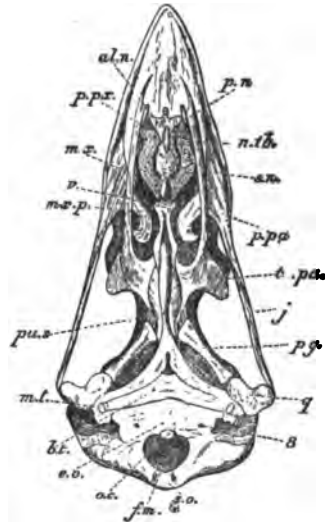

FIG. 26.—Skull of nestling Rook (*Corvus frugilegus*), palatal view, natural size. The prenasal region (p.a.s.) is trifoliate; the median rod, looking forwards, is the remains of the prenasal or basitrabecular bar; the lateral leaves of cartilage, looking backwards, are the recurrent ventral extremities of the trabecular cornua; between the alinasal turbinals the base of the septum nasal retains its flatness; it is formed by the inter-nasal part of the trabecula.

Genus *Colinus*." *The Ibis*, July 1872, plate 10, pp. 261-280; "On the Motmots," *Ibis*, Oct. 1872, plates 13-15, pp. 383-412; "On the Upupids," *Ibis*, April 1873, plates 5-7, pp. 181-311."

<sup>3</sup> For descriptions of the skulls of *Passerine* birds, see Parker on the "Skull of the Crow," *Monthly Micr. Journ.*, Nov. 1, 1872; on that of the "Tit" (*Parus*), *ibid.*, Jan. 1, 1873; and on that of the "Thrush," *ibid.*, Mar. 1, 1873. See also, as referred to by Professor Huxley, Nitzsch's article "Passerina" in Erach and Gruber's *Encyclopaedia*, 1840, and his paper, "Ueber die Familie der Passerinen," in the *Zeitschrift für die Gesammten Naturwissenschaften*, 1862. As the figure given above is of a young bird, the reader is also referred to Professor Huxley's "Palatal View of the Raven's Skull" (*op. cit.*, p. 451, fig. 32); of that of the "Grosbeak," fig. 33; and of the "Swift," fig. 34. See also Murie "On *Fregilupus*," *Proc. Zool. Soc.*, June 16, 1874, plates 61, 62.

of the vomers with the alinasal wall and turbinal, and the possession, by the embryo bird at least, of a pair of "upper labials," corresponding to the *inner* upper pair in Snakes, Sharks, and Skate; the vomers are either partial or entire ossification of these cartilages. Besides these, there reappear in most of the *Ægithognathæ* the so-called "inferior turbinals," or nostril-bones of the Snake and Lizard, and these are attached to the shoulders of the double, and generally, ox-face-shaped vomer.<sup>1</sup> The nasal labyrinth is very large in the Rook, but does not differ in essentials from that of the Fowl, above described.

The septum nasi (*s.n.*) retains much of its original flatness below, and is thus *alate*; the vomer (*v.*) of the young bird is broad and grooved above; in the old bird, ossification running some distance along the alinasal wall and alinasal turbinal (*n.tb.*), the bone becomes not only emarginate, but also very massive in front. In the Lark (*Alauda arvensis*) this bony matter in the macerated skull leaves huge goat-horn processes to the fore-angles of the vomer. *Ægithognathism* occurs in different degrees; thus, we may have its morphological conditions—

- a. Incomplete: as in *Turnix*.
- b. Complete var. 1: *Pachyrhamphus*, *Pipra*.
- c. Complete var. 2: *Corvus*, *Alauda*.
- d. Compound: *Gymnorhinus*, *Artamus*.

a. Incomplete. Here the large "labials" are imperfectly ossified by the two vomers, and these bones are only strongly attached to the nasal labyrinth by fibrous tissue.

b. Complete var. 1. In these cases the labials are often only imperfectly ossified by the vomerine centres; these centres also are distinct from those ossifying the alinasal cartilages; but the union of these parts is perfect.

c. Complete var. 2. In these cases the labials are often small and completely ossified by the vomers; but the bony deposit runs riot into the alinasal wall and turbinal, so that in the adult all distinction of the parts may be lost.

d. Compound. Here the flat arcuate end of the maxillo-palatine is free, but the mass of that plate meets its fellow of the opposite side and coalesces with it, and with a highly ossified nasal septum. In these *Southern types* the "transpalatine" is a long spike, as in the *Alcedidae*. In all these varieties the septo-maxillaries may, and do mostly, occur. They cannot always be found.<sup>2</sup>

Concluding our remarks upon this morphological type, its value is shown by this—that it is exactly superimposable upon the *Coracomorpha*, if we reject the bird that shows its initial or imperfect condition, as the Hemipod, and stubbornly hold to the popular view that Swifts are a kind of Swallow—for as to their nobler part, their head, they are merely a variety of that type. Thus the zoologist and the morphologist may here join hands.

**The SAUROGNATHOUS Type—Cranium of the Pica Minor.**—This group, Professor Huxley's *Celeomorpha* (*op. cit.* 448 and 467), is so remarkable and difficult of determination, that although our author saw clearly many most important characters (quite sufficient for the elimination of

this group from the *Coccygomorpha*), yet the materials at hand were not sufficient for a perfect account of this type of skull. A fellow-worker has had fuller opportunities.<sup>3</sup> Like the Parrots, these birds form a relatively small and neat group; the most outlying forms are *Picus minor* and *Yunc*, but these form no obstruction to their classification. Mr Parker's proposed morphological term for these birds is *Saurognathæ*, and the two terms can be superimposed, *Celeomorpha* being their zoological name. Professor Huxley saw that these birds were not *desaurognathous*; that their vomerine moieties remained distinct; that their maxillo-palatines are but little developed; and that supernumerary bones on the inner edge of the palatines in *Picus minor* corresponded to the curious bars that are seen in the larger kinds. He also, with quick insight, says that their palate exhibits a "degradation and simplification of the *Ægithognathous* structure." This is strictly true; the elementary parts are the same, but in the Woodpeckers they retain a very *Reptilian* distinctness, and even arrest of growth. Yet with that arrest there is combined a modification and metamorphosis of certain parts, such as is undergone by no other type. They are in some respects the most simple and embryonic, and in others the most highly specialized birds in the whole class. Their basi-ptyergoids are arrested; their basi-temporal region large and wide. Two or three tympanics on each side help to form their remarkable *cowrie-shaped* ear-drum, which is mainly built up by the basi-temporals and exoccipitals. The lower end of the quadrate has the usual form; the bone itself is short; the pterygoids are long, slender, angular, and forked; the lower and foremost fork is the meso-ptyergoid element, which does not become segmented off, and thus their pterygoids answer to that of a Snake or Lizard, and reach to the vomer.<sup>4</sup>

The palatines (fig. 27, *pa.*) have their postero-external

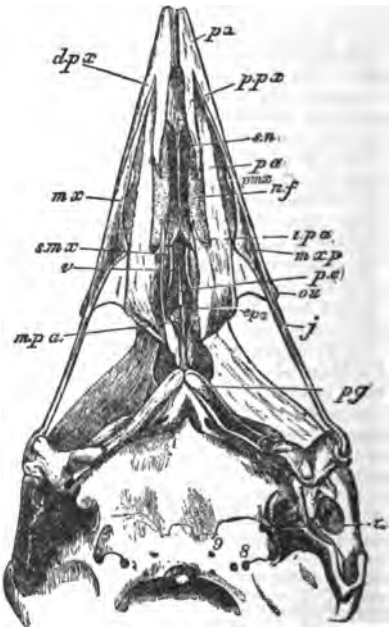

FIG. 27. Palatal view of skull of a nestling of *Picus minor*, X 4. *pa.*, palatine; *pp.*, posterior palatine; *sn.*, nasal spine; *pa.*, palatine; *ppa.*, posterior palatine process; *m.p.a.*, medio-palatine; *s.m.x.*, septo-maxillary; *v.*, vomer; *m.x.*, maxilla; *l.p.a.*, lateral palatine; *m.x.p.*, maxillary process; *p.e.*, posterior element; *o.v.*, orbital vomer; *j.*, jugal; *p.g.*, postglenoid.

<sup>1</sup> There is not space here to give illustration of all these details; but papers by Mr Parker are now (1875) appearing in the *Transactions of the Linnean and Zoological Societies*, in which these structures are copiously illustrated.

<sup>2</sup> Professor Huxley (*op. cit.*, p. 472) was as unfortunate in his specimen of *Menura* as in that of *Trochilus* (see p. 468, where these birds are said to have their vomer truncated, whereas it is *spiked*); for in Mr Garrod's specimens of the Lyre-bird's skulls the maxillo-palatines are large bony plates, like those of ordinary *Coracomorpha*. The vomer of *Menura* is exactly like that of the Chough (*Fregilus graculus*), and also of many young *Coracomorpha*, for the two moieties do not necessarily form a re-entering angle or notch in front; that is often largely due to the osseous growth creeping into the alinasal cartilages. *Menura* has one character of great importance, viz., it retains the super-orbital chain of ossicles, like *Poepchia* and the *Tinamida*.

<sup>3</sup> See Mr Parker's paper "On the *Picidae*," in the *Linnean Transactions*, 1875, series 2, vol. 1, plates 1-5.

<sup>4</sup> See Günther "On *Halteria*," *Phil. Trans.*, 1837, plate 1, fig. p. 5.

angle either rounded or obtuse-angled. The post-palatine region is bevelled off remarkably; but in *Picus minor*, the lips of this part are greatly developed, as in the lower Passerines of South America;<sup>1</sup> but in them this marked region appears to be always ossified directly from the main bone, whilst in *Picus* it is a separate ossification—a perfectly unique thing, as far as the writer's knowledge goes. The broad main part of the palatine suddenly narrows at its first third, the remaining two-thirds being the long eplintary prepalatine, opposite the beginning of which the inner lip runs into an "inter-palatine" spike (*i.pa.*) The ethmo-palatine processes are extremely long in the nestling of *Yunz*, and very short in that of *Picus minor* (*c.pa.*) They are the free anterior ends of that ascending plate which lies under the parasphenoidal rostrum. These plates are united by a cartilaginous commissure, dagger-shaped, which ossifies as the most marked medio-palatine (*m.pa.*) seen in the class. The prepalatine band passes between the dentary and palatine spurs of the premaxillary (*pr.*), as in the adult fowl. Oddly enough, they run on the inner side of the palatal process of the premaxillary in most of the *Agithognathæ*. This is an after-modification, for in the young of *Struthio camelus* and *Gallus domesticus* the fore-end of the one and the hinder end of the other process are broad, and the two unite by suture. In the higher birds the processes overlap on either side, but orderly as to natural groups. The free end of the premaxillary palatine process looks backward to the free inter-palatine spur in the young (fig. 27); but in old birds, as may well be seen in *Gecinns viridis*, *Picus anatis*, and *P. major*, these parts are formed into delicate bridges of bone, which also are thrown along to the ethmo-palatines. This is done by the vomerine series. The "septo-maxillaries" are not single conchoidal plates of bone, as in the Snake and Lizard; but are broken up into grains, which melt into each other again. Even the vomer itself is double on each side in *Gecinns viridis*, whilst in *Hemilophus fulvus* there are three septo-maxillaries on the left side and five on the right. These ossicles lie on the inner side of the palatines, and are normally connected behind by means of the vomer to the ethmo-palatine; where *normal ornithic ankylosis* takes place in adult birds, there these curious length-wise bridges are formed. Yet this is only part of their complexity, for median septo-maxillaries appear, two of them in *Gecinns*, and these are found in the substance of long, right and left, *labial cartilages*. These do not ossify in *Hemilophus*, but unite at the mid-line; in *Gecinns* they overlap largely to gain the mid-line. In the same species, to add to the complexity, a large shell of bone, from the *inturned alinasal wall*, becomes more or less free of its own origin, and unites to the vomerine series. All this has been seen and explained by writing and by figures.<sup>2</sup>

The maxillo-palatine processes scarcely grow inwards at all in *Picus minor*; in *Yunz* they are rather larger; larger still in *Picus minor* (fig. 27, *m.c.p.*) Where they are largest, as in *Gecinns*, they just rest upon the outer edge of the palatines, covering nearly half their width. In all, the under face of the maxillary has an open pneumatic space at this part. But, as if to fill up that which was wanting, a separate palatine plate appears on the inner edge of the maxillary further forward, *only on the left side*, however (fig. 27, *p.m.*) This is a semi-oval wedge of bone, and has its asymmetrical counterparts in several families of the *Coracomorpha*, viz., *Emberiza*, *Cardinalis*, &c.

These birds are saurognathous in other respects, e.g., their nasal labyrinth is unusually simple. The "inferior

turbinal," which has three coils in *Rhea* and *Tinamus*, and two in most birds, is in *Gecinns* merely bi-alate; in *Yunz* it makes less than a single turn, whilst the alinasal turbinal of that bird has two turns, and that of *Gecinns* one. *Gecinns* is in all respects the most specialised, *Picus minor* the most embryonic, and *Yunz* the most passerine of the *Coleomorpha*. Also, in *Gecinns* the nasal labyrinth is most ossified, and in *Yunz* least. In *Gecinns* the "columella auris" has two supra-stapedial spurs and two infra-stapedial bands, which have united with the tongue-shaped stylo-hyal: this has in it a bony centre. The small cerato-hyals early coalesce into one arrowhead-shaped bone, and then comes a very long, highly ossified, and elastic basi-hyal, with no uro-hyal behind it. Joined to this are a pair of lower thyro-hyals, half its length; but the upper pieces are four times the length of the lower, and they, passing first down the sides of the upper part of the neck, again turn gently upwards and forwards, ploughing themselves a furrow on the skull top, and deflecting gently to the right nasal roof, where they end.

All these things being considered, it will seem contradictory now to assert the great uniformity of the skulls of Birds, and indeed of the Birds themselves. Yet so it is; and the countless modifications that offer themselves for observation are gentle in the extreme. One form often is seen to pass into another by almost insensible gradations. One thing is certain, namely, that an anatomist not familiar with this class, and coming to its study fresh from the Reptiles, would find himself at fault at every turn; for he would see changes altogether as great as if he had passed from the Helminthoid types, and from mere *larvæ* and *pupæ* of the Insects to the (to him supposably) unthought-of *imagines* that spring from those low and worm-like stages.

In the rest of the Birds' organisation abundant evidence of the same specialization will be seen. The mind fails to desire more beauty or to contemplate more exquisite adaptations. An almost infinite variety of Vertebrate life is to be found in this class. Of its members some dig and bury their germs, which rise again in full plumage, whilst others watch and incessantly feed their tender brood in the shady covert or "on the crags of the rock and the strong place." In locomotion some walk, others run, or they may wade, swim, plunge, or dive, whilst most of them "fly in the open firmament of heaven."

#### THE VERTEBRAL COLUMN, RIBS, AND STERNUM.<sup>3</sup>

The spinal column of birds contains numerous and well-ossified vertebrae, a considerable number of which (more than six) are ankylosed together to form a sacrum. Of the vertebrae which enter into the composition of this complex bone, however, not more than from three to five can be regarded as the homologues of the sacral vertebrae of a Crocodilian or Lacertilian Reptile. The rest are borrowed, in front, from the lumbar and dorsal regions; behind,

<sup>1</sup> See Parker "On the Osteology of Gallinaceous Birds and Tinamous," *Trans. Zool. Soc.* vol. v., 1863; "On the Systematic Position of the Crested Screamer (*Chauna chavaria*)," *Proc. Zool. Soc.*, Dec. 8, 1863; "On the Osteology of *Microglossa alata*," *Ibid.*, Feb. 28, 1865; "On the Osteology of the Kagu (*Rhinoceros jubatus*)," *Trans. Zool. Soc.*, vol. vi. Huxley; "On the Classification of Birds," *Proc. Zool. Soc.*, April 11, 1867; "On the Alectoromorpha," *Ibid.*, May 14, 1868; "The Anatomy of Vertebrate Animals," 1871, p. 272. M. Edmond Alix, *Essai sur l'Appareil Locomoteur des Oiseaux*, Paris, 1874,—a most important work. The writer will often use the "very words" of Professor Huxley, despairing, as he does, of coming near that excellent writer, either in *condensation* or *order*. The working student will find the axial skeleton of the Ostrich most profusely and beautifully illustrated in Professor Mivart's paper (*Trans. Zool. Soc.*, vol. vii. part 7). Every ornithologist will be grateful for that piece of work.

<sup>2</sup> See Parker "On *Agithognathæ*," part I, *Zool. Trans.*, 1875, plates 54-62.

<sup>3</sup> *Ibid.*, "On the *Picidae*," op. cit.

from the tail. The cervical region of the spine is always long; and its vertebrae, which are never fewer than eight, and may be as many as twenty-three, are, for the most part, large in proportion to those of the rest of the body.

The atlas is a relatively small, ring-like bone; and the transverse ligament may become ossified and divide its aperture into two—an upper for the spinal cord, and a lower for the odontoid process of the axis vertebra. The *odontoidem* is always ankylosed with the second vertebra, and constitutes a peg-like odontoid process.

The spines of the succeeding cervical vertebrae are often obsolete, and are never very prominent in the middle region of the neck. The anterior faces of their elongated vertebral centra are *convex from above downwards*, and *concave from side to side*; whilst the posterior faces are cylindrical, slightly excavated *from above downwards*, and *convex from side to side*. (The contrary of this is stated in Professor Huxley's *Verteb. Anim.*, p. 276, where the author, by a *lapsus memoria*, puts it *vice versa*.) Hence, in vertical section the centra appear *opisthocœlous*; in horizontal section, *procoelous*, and not the contrary, as is stated by our author; and the structure is exceedingly characteristic of birds. The under surfaces of the centra frequently give off median inferior processes. In the *Ratites* it is obvious that the cervical vertebrae have short transverse



FIG. 26.—A cervical vertebra from the middle of the neck of a Fowl; natural size. a, side view; b, upper view; c, lower view; p.a., pre-zygapophyses; p.s., post-zygapophyses.

processes and ribs, disposed very much as in the *Crocodylia*. For, in young birds, the anterior end of the lateral face of each vertebra bears two small processes, an upper and a lower; and this expanded head of a styliform rib is articulated with these by two facets, which represent the capitulum and the tuberculum (Huxley, *op. cit.*, p. 276). In the chicken of the Emeu (*Dromaeus nova-hollandia*) the writer, in 1843, carefully worked out and figured these parts. Of the twenty cervical vertebrae only the atlas and axis were devoid of distinct ribs; this individual was six weeks old. These riblets were bony wedges, with a sharp point; but that was free, and the thick upper end was jammed in between upper and lower transverse processes (*diapophysis* and *parapophysis*). The last but one of the ribs became suddenly larger, and the last was two-thirds the size of its successor—the first dorsal. Then followed six large ribs on each side, the last two floating. The vertebra bearing the last of these, and twenty more, are closely embraced by the fore-and-aft growth of the ilium, and form the so-called sacrum. Of the twenty vertebrae between the first overlapped bone with a floating rib and the nine ribless caudals, there are five with free ribs, small; and hatchet-shaped, quite like those in the neck of the Crocodile. These, from being attached to a parapophyseal cup near the fore-end of the centrum, get more forward, and wedge in between their own vertebra and the one in front. The next four vertebrae, which give exit to the sacral plexus (or at least to most of it), have no ribs, and are very broad and short. They develop lamellar upper transverse processes, but their spines are aborted. Then come eleven vertebrae, in front of the free caudal, that have short ribs; the first two pairs are ankylosed already, then *four pairs* are distinct, and the remaining five have their ribs ankylosed, and then becoming shorter and more pedate externally, get further

backwards from the centrum. Thus, in a Bird as old as six weeks after hatching, there are eighteen pairs of cervical, and nine pairs of so-called sacral ribs still distinct. Moreover, the ribs are quite aborted on the first and second cervical, on the four *true* sacral,—perchance, the next after this is also sacral,—and on all the caudal vertebrae which have only papilliform transverse processes. There are fifty-five vertebrae in all in the Emeu, thus:—cervical, twenty; dorsal, five; dorso-lumbar (the first with a large rib and really the sixth dorsal), six; sacral (proper), four; uro-sacral, eleven; caudal, nine. We shall return to these data in describing the sacrum of the Fowl.

With age the cervical ribs (of the *Ratites*) may become completely ankylosed. In *Apteryx australis* one, below, remains free; in *Struthio camelus*, two; and in *Dromaeus nova-hollandia*, three; and then they appear like transverse processes, perforated at the base by a canal, which, as in the *Crocodylia*, contains the vertebral artery and vein, and the main trunk of the sympathetic nerve. The cervical ribs and transverse processes are similarly disposed in very young *Carinatae*; but in these birds their form frequently becomes much modified in the adult, and they develop prolongations which extend downwards and inwards, and protect the carotid artery or arteries. The neural arches have well-developed pre- and post-zygapophyses. The ribs of one or two of the posterior cervical vertebrae become elongated and freely movable in the *Carinatae*, as in the *Ratites*.

The first dorsal vertebra is defined as such by the union of the ribs with the sternum by means of a sternal rib, which not only, as in the *Crocodylia*, becomes articulated with the vertebral rib, but is converted into complete bone, and is connected by a true articulation with the margin of the sternum. The number of the dorsal vertebrae (reckoning under that head all the vertebrae, after the first dorsal, which possess distinct ribs, whether they be fixed or free) varies. The centra of the dorsal vertebrae either possess cylindrical articular faces, like those of the neck, as is usually the case; or more or fewer of them may have their faces spheroidal, as in the Penguins [Plovers (and their kin *Vanellus cristatus*, *Totanus fuscus*, &c.), Gulls, Cormorants, and Parrots]. In this case the convex face is anterior, the concave, posterior. They may, or may not, develop inferior median processes [which may be simple, as in the Cormorant, where they exist on several lower cervical, on all the dorsal, and in five sacro-lumbar; or they may bifurcate into two broad, bony leaves, as in *Colymbus*]. They usually possess well-marked spinous processes [which begin in the two or three lower cervicals]. Sometimes they are slightly movable upon one another [bound strongly, in many cases, by ossified tendons of great strength and elasticity]; sometimes they become ankylosed together into a solid mass. [When this takes place the last cervical is ankylosed to the three first dorsal, as in the fowl, the fourth remaining free, and the fifth coalescing with the lumbar; or, as many as *five* may ankylose together, leaving one free, and the last ankylosed to the lumbar, as in *Falco anatum*. But this number often differs with age, as may be seen in different individuals of *Prophias crepitans*, and other, more typical, *Cranes*.]

It is characteristic of the dorsal vertebrae of Birds that the posterior, no less than the anterior, vertebrae present a facet or small process on the body, or lower part of the arch, of the vertebra for the capitulum of the rib, while the upper part of the neural arch gives off a more elongated process for the tuberculum. Thus, the transverse processes of all the dorsal vertebrae of a Bird resemble those of the two anterior dorsals of a Crocodile, and no part of the vertebral column of a Bird presents transverse processes with a stop for the head of the rib, like those of the

great majority of the vertebræ of *Crocodylia*, *Dinosauria*, *Dicynodontia*, and *Pterosauria*. [The triangular facets for the tubercular processes are scarcely scooped; those for the capitular are neat, round, shallow cups.] The discrimination of the proper lumbar, sacral, and anterior caudal vertebræ, in the ankylosed mass which constitutes the so-called "sacrum" of the Bird, is a matter of considerable difficulty. The general arrangement is as follows:—The most anterior lumbar vertebra has a broad transverse process, which corresponds in form and position with the tubercular transverse process of the last dorsal. In the succeeding lumbar vertebræ the process extends downwards; and in the hindermost [the *third*] it is continued from the centrum, as well as from the arch of the vertebra, and forms a broad mass which abuts against the ilium.<sup>1</sup> This process might well be taken for a sacral rib, and its vertebra for a proper sacral vertebra. But, in the first place, I find no distinct ossification in it [there are *five* of these lumbar vertebræ in the Emeu, two more than in the Fowl, and they all have distinct ribs; and the *ribless* vertebræ are five in the Fowl and four in the Emeu]; and, secondly, the nerves which issue from the intervertebral foramina in front of and behind the vertebra enter into the lumbar plexus, which gives origin to the crural and obturator nerves, and not into the sacral plexus, which is the product of the nerves which issue from the intervertebral foramina of the proper sacral vertebræ in other *Vertebrata*. Behind the last lumbar vertebra follow, at most, five vertebræ which have no ribs; but their arches give off horizontal, lamellar processes, which unite with the ilia. [In the Emeu these *four* vertebræ show not the least trace of ribs, and are flat bricks of bone, below, jammed together like the cervical centra of a *Cetaceus*.] The nerves which issue from the intervertebral foramina of these vertebræ unite to form the sacral plexus, whence the great sciatic nerve is given off; and I [Professor Huxley] take them to be the homologues of the sacral vertebræ of the *Reptilia*. The deep fossæ between the centra of these vertebræ, their transverse processes, and the ilia, are occupied by the middle lobes of the kidneys. If these be the true sacral vertebræ, it follows that their successors are anterior caudal. They have expanded upper transverse processes, like the proper sacral vertebræ; but, in addition, three or four of the most anterior of these vertebræ possess ribs, which, like the proper sacral ribs of Reptiles, are suturedly united, or ankylosed proximally, with both the neural arches and the centra of these vertebræ; while, distally, they expand and abut against the ilium. The ankylosed caudal vertebræ may be distinguished as *uro-sacral*.

We now give a table showing the number of bones in the so-called sacrum of Birds—so many vertebræ as are covered by the ilia and ankylosed together. Here the

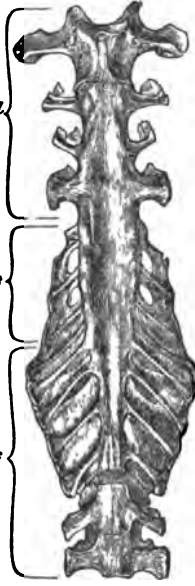

FIG. 29.—The "sacrum" of a young Fowl; natural size, seen from below. *d*., dorso-lumbar, *a*., sacral, *u.a.* caudal vertebræ.

distinction between *dorsal* and *lumbar* is, that the former possess elongated ribs; and the table will show forms of extreme *length* and of extreme *shortness*, for a Bird; and also, as in the Fowl, of a medium type. Most of the instances are derived from the sacral bones of young Birds.

	d.	a.	u.a.	Total.
<i>Dromæus nova-hollandia</i> ...	1	5	4	11 = 21
<i>Cygnus olor</i> .....	2	5	4	10 = 21
<i>Colymbus glacialis</i> and <i>C. septentrionalis</i> .....	2	3	5	7 = 17
<i>Gallus domesticus</i> .....	1	3	5	6 = 15 <sup>2</sup>
<i>Aluco tephidæ</i> .....	1	2	4	6 = 13
<i>Upupa epops</i> .....	1	2	3	5 = 11
<i>Cypselus apus</i> .....	2	1	3	5 = 11

In both the Hoopoe and the Swift the first of these sacrales has an outstanding rib-process. In the Swift the rib on the second of the enclosed dorsals is very long, and its flanking rib nearly reaches the sternum. The next or third vertebra, the lumbar, has *below* it, neither reaching to it above, nor by its sternal piece to the sternum below, another rib; it is two-thirds the size of its predecessor, and only occurs on the *right* side. This will show how, by gradations the most gentle, the vertebræ and their ribs are specialised in each particular type, and also how very arbitrary is our nomenclature.

The Swan has eight free vertebræ behind the *uro-sacral*, and as the last of these is in these types composed of ten vertebræ originally, there are primarily twenty-seven vertebræ in the Swan's tail. The caudal vertebræ which succeed the *uro-sacral* may be numerous and all distinct from one another, as in *Archæopteryx*, or few and distinct, as in *Rhea*; but more generally, only the anterior caudal vertebræ are distinct and movable, the rest being ankylosed into a ploughshare-shaped bone or *pygostyle*, which supports the tail feathers and the uropygial gland, and sometimes, as in the Woodpecker and some other Birds expands below into a broad polygonal disk.

The centra of the movable presacral vertebræ of Birds are connected together by fibro-cartilaginous rings, which extend from the circumference of one to that of the next. Each ring is continued inwards into a disk, with free anterior and posterior faces—the *meniscus*. The meniscus thins towards its centre, which is always perforated. The synovial space between any two centra is, therefore, divided by the meniscus into two very narrow chambers, which communicate by the aperture of the meniscus. Sometimes the meniscus is reduced to a rudiment; while, in other cases, it may be united, more or less extensively, with the faces of the centra of the vertebræ. In the caudal region the union is complete, and the meniscus altogether resembles an ordinary intervertebral cartilage.

A ligament traverses the centre of the aperture of the meniscus, and in the Duck contains the intervertebral portion of the notochord. As Jäger<sup>3</sup> has shown, it is the homologue of the odontoid ligament in the cranio-spinal articulation, and of the pulpy central part of the intervertebral fibro-cartilages in *Mammalia*. All the vertebral ribs in the dorsal region, except, perhaps, the very last free ribs, have widely separated capitula and tubercula. More or fewer have well-ossified uncinæ processes attached to their posterior margins, as in the *Crocodylia* [and *Hatteria*]. These are separate, both as cartilage and as bone, at first; we have only failed to find them in the Crested Screamer (*Chauna chavaria*). Among the *Ratites* they are very small and few in number; in the Emeu and in the Apteryx they are large; they evidently correspond with the unserved rib-flaps of the little Ant-eater (Parker's *Shoulder*

<sup>1</sup> It would be more proper to say that ossification extends into and from the centrum as well as from the neural arch. The process, like other processes, exists before the centrum is differentiated from the arch by ossification (Huxley).

<sup>2</sup> Professor Huxley's figure (80, p. 278) only shows *five* *uro-sacral*, there are *six* in the Fowl.

<sup>3</sup> "Das Wirbelkörpergelenk der Vögel," *Sitzungsberichte der Wiener Akademie*, 1858.

*girdle and Sternum, plate 22, figs. 19, 20.)* The vertebral ribs are completely ossified up to their junction with the sternal ribs.

THE STERNUM, LIMB-GIRDLES, AND LIMBS.<sup>1</sup>

The sternum in Birds is a broad plate of cartilage which is always more or less completely replaced in the adult by membrane bone.<sup>2</sup> It begins to ossify by, at fewest, two centres, one on each side, as in the *Ratites*. In the *Carinatae* it usually begins to ossify by five centres, of which one is median for the keel, and two are in pairs for the lateral parts of the sternum. Thus the sternum of a Chicken is at one time separable into five distinct bones, of which the central keel-bearing ossification (fig. 30) is termed the



FIG. 30.—Sternum of a Chick (*Gallus domesticus*) three days old, lower view, X three diameters. The cartilage is shaded and dotted, and the bony centres are light and striated. The front external processes are the "costals," and are ossified each by a *pleurostemon*; the median front process is the rostrum, and on each side of it are seen the coracoid grooves. The fore-part of the middle, most of which is carinate, is ossified already by the *lophosteum*; the forked xiphoids on each side are each largely occupied by a *metostemon*; on the right side the sternal ribs are shown.

*lophosteum*, the antero-lateral piece which articulates with the ribs, *pleurostemon*, and the postero-lateral bifurcated piece, *metostemon*.

[In *Turnis* there are two more centres, mesiad of the pleurostema, these are the *coracostea*; in *Dicholophus* the median part suddenly dilates, behind, into a heart-shaped flap of cartilage, which has an endosteal patch, the *urostemon*.]

Though the sternum, in most Birds, seems to differ very much in form from that of the *Reptilia*, it is rhomboidal in the *Casuaridae*, where it differs from the Reptilian sternum chiefly in the greater proportional length of its posterior sides, the absence of median backward prolongations, and

the convexity of its ventral surface. But in other Birds, and notably in many *Carinatae*, the antero-lateral edges, which are grooved to receive the coracoids, form a much more open angle than in the *Reptilia*, while the postero-lateral edges become parallel or diverge: and a wide, straight, or convex transverse edge takes the place of the posterior angle. Two, or four, membranous fontanelles may remain in the posterior moiety of the sternum when ossification takes place, and give rise to as many holes, or deep notches, separating slender processes in the dry skeleton. All these correspond with so many divisions of the xiphoid process of the sternum in *Mammalia*, and hence are called *middle*, *internal*, and *external xiphoid processes*. Sometimes a median



process, *rostrum* or *manubrium* (figs. 30, 31), is developed from the anterior angle of the sternum, and its antero-lateral angles are developed into *costal processes*, which may bear the articular surfaces for more or fewer of the ribs. The two last-named structures are very distinct in the *Coracomorpha*, or *Passerine Birds*.

The extent to which the keel of the lophosteum is developed in the *Carinate birds* varies very much. In *Strigops* it is rudimentary; in birds of powerful flight, as well as in those which use their wings for swimming, it is exceedingly large.

The *pectoral arch* presents a long, narrow, and recurved scapula (fig. 32), without any supra-scapula, and a coracoid

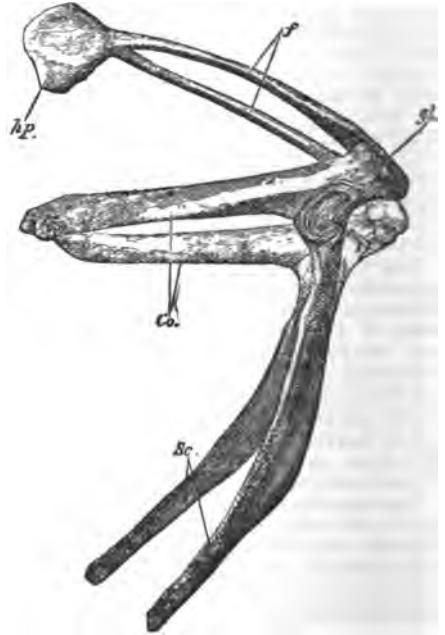

FIG. 32.—Shoulder-girdle of adult *Puffin*, nat. size; oblique side view inverted; sc, scapula; co, coracoid; cl, clavicles; ap, hypocleidum, or later-clavicle; gl, glenoidal cavity.

<sup>1</sup> See Harting, *L'Appareil Episternal des Oiseaux*, Utrecht, 1864; Parker, "On *Balaeniceps rex*," *Trans. Zool. Soc.*, vol. iv, plates 66, 67; "On Gallinaceous Birds and Tinamous," *T. Z. S.*, vol. v, plates 35-41; "On the Kagu," *T. Z. S.*, vol. vi, plates 91, 92; *Shoulder-girdle and Sternum*, plates 12-18; Huxley, "On the *Alcedoromorpha*," *P. Z. S.*, May 14, 1868; *Anatomy of Vert. Anim.*, p. 280; Owen, "On *Alca impennis*, L.," *T. Z. S.*, vol. v, p. 817, plates 51, 52; "On the Osteology of the Dodo," *T. Z. S.*, vol. vi, plates 15-24, and *T. Z. S.*, vol. vii, plates 64, 65; "On *Dinornis*," *T. Z. S.*, vol. vii, plates 7-9; "On *Aptornis defensor*," *T. Z. S.*, vol. vii, plates 42, 43, and *T. Z. S.*, vol. viii, plates 14-16; Murie, "On *Geopelia occidentalis*," *Proc. Zool. Soc.*, Feb. 27, 1868, p. 163; "On *Scotopelia peli*," *Jour. Anat. and Phys.*, vol. vi, p. 170, plate 11; "On *Todus*," *Proc. Zool. Soc.*, May 21, 1872, pp. 664-680, plate 55; "On *Collus*," *The Ibis*, July 1872, pp. 263-280, plate 10; "On the *Motmots*," *Ibis*, Oct. 1872, pp. 383-412, plates 12-15; "On the *Upupidae*," *Ibis*, April 1873, pp. 181-211, plates 5-7; "On *Fregilupus*," *Proc. Zool. Soc.*, June 16, 1874, pp. 474-488, plates 61, 62; M. Edmond Alix, *Essai sur l'appareil locomoteur des Oiseaux*, Paris, 1874.

<sup>2</sup> These statements do not apply to *Archaeopteryx*; its structure is very imperfectly known (Huxley).



(*ca.*), fitted by its proximal end in the groove in the antero-lateral edge of the sternum. The inner ends of the coracoids often overlap, as in *Lacertilia*; otherwise the shoulder-girdle is unlike that of any of the *Reptilia*, except the *Pterosauria*. The coracoid is usually completely ossified, and presents no fontanelle. There is no distinct epicoracoid. The two bones take nearly equal shares in the formation of the glenoidal cavity, and usually remain unankylosed and distinct in this region.

In the *Ratites* the long axis of that part of the scapula which lies near the glenoidal cavity is parallel or coincident with that of the coracoid, and the two bones become completely ankylosed. But in all the *Carinatae* the long axis of the scapula forms an acute, or only slightly obtuse angle (*Ocydromus, Didus*) with that of the coracoid. A small bone, the *scapula accessoria*, is developed on the outer side of the shoulder-joint in most *Coracomorphae* and *Celebomorphae*.

In the *Carinatae* the glenoidal end of the scapula is divided into two portions: a *glenoidal process*, which expands to form the upper part of the glenoidal cavity, and to unite with the coracoid; and an *acromial process*, which gives attachment to the outer end of the clavicle. The glenoidal end of the coracoid is in like manner divided into two portions: a *glenoidal process*, which unites with the scapula, and a *clavicular process*, which articulates with the outer surface of the clavicle near its outer end. The clavicular process of the coracoid does not represent the procoracoid of *Lacertilia*; rudiments of that bone unite with the clavicle. In the *Ratites* there is no distinct clavicular process; but the anterior part of the coracoid, near the glenoid cavity, may be produced and separated by a notch or fontanelle from the rest, or developed down to the sternum (in *Struthio*) as a lacertilian procoracoid. There is no trace of clavicles in *Apteryx, Rheca, Struthio*, and some Parrots; but in the latter there is generally an ossified, distinct, short procoracoid. In the Emu and in some *Carinatae* (*Didus, Rhamphastos toco, Corythaix buffoni, Buceros albirostris*), the clavicles remain distinct from one another, or connected only by fibrous tissue; but in the majority of Birds they are very early ankylosed together, and with the representative of the inter-clavicle, in the middle line, into a single bone, the *furculum*, the strength of which bears a pretty close relation to the exertion required of the wings in flight or in natation. In the Passerine Birds the scapular end of the clavicle is enlarged by a procoracoid rudiment of cartilage, which ossifies separately, producing the expansion above and in front called *epicaudium*.

A median process (*hypocleidium*) is frequently developed from the inter-clavicular part of the furculum, and this may be united with the carina of the sternum by strong fibrous tissue, or even by continuous ossification. In *Opiathocomus*<sup>1</sup> the furculum is ankylosed with the manubrial part of the sternum on the one hand, and with the coracoids on the other. Ankylosis of the furculum with the coracoid has also been observed in *Didus*,<sup>2</sup> and with both keel and coracoid in *Fregata aquila* (*Shoulder-girdle and Sternum*, p 15, 1; see also the actual specimen in the museum of Col. Surg. Eng.)

The fore-limb of a Bird, when in a state of rest (fig. 33), exhibits a great change of position, if it be compared with that of an ordinary Reptile; and the change is of a character similar to, but in some respects greater, than that which the arm of a man presents when compared with the fore-limb of a quadruped! Mammal. The humerus lies parallel with the axis of the body, its proper ventral

surface looking outwards. The fore-arm is in a position midway between pronation and supination, and the

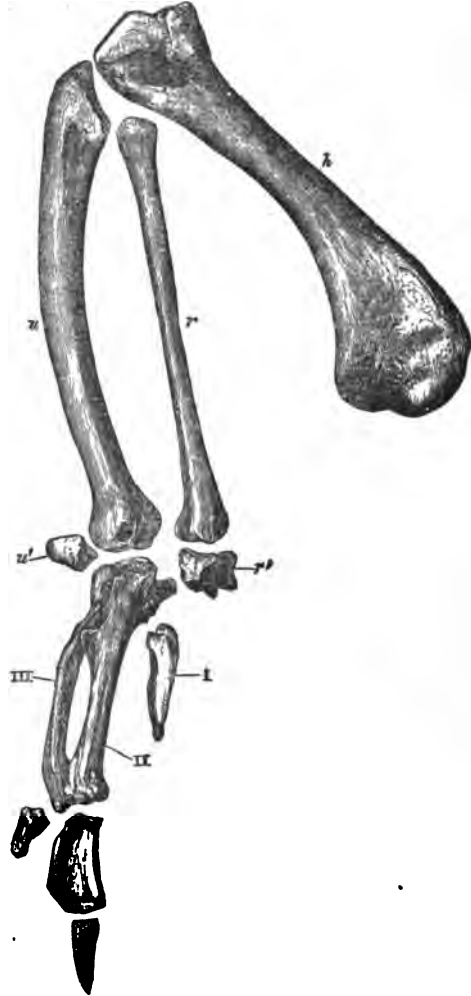

FIG. 33.—Bones of Fowl's right wing, adult, nat. size. A, humerus; B, radius; C, ulna; D, E, F, G, radial and ulnar carpal bones; with the three digits, I, II, III.

manus is bent back upon the ulnar side of the fore-arm in a position not of flexion but of abduction.

In ordinary Birds the proximal end of the humerus is expanded, and its articular head transversely elongated. Its ventral face is convex, and provided with a strong preaxial ridge, which gives attachment to the pectoral muscle. The proper dorsal face is concave from side to side, especially towards the postaxial margin, where the pneumatic aperture occurs in those birds which have the humerus hollow. The distal end is expanded, and the articular surface for the radius is a convex facet, directed obliquely inwards on its ventral face. In this respect the Bird's humerus exaggerates a feature of that of the Lizard's.

In the *Ratites* these peculiarities are very feeble, or not at all, marked, the humerus being a slender, cylindrical, slightly-curved bone. In the *Casuaridae, Dinornithidae*, and *Apterygidae*, the fore-limb is extraordinarily reduced, and may become rudimentary. In the Penguins and, to

<sup>1</sup> Huxley "On the *Alectoromorphae*," p. 304, figs. 8 and 9.  
<sup>2</sup> Owen "On the Dodo," *Trans. Zool. Soc.*, vol. vi. part 2, p. 68, plate 20, fig. 4.

a less degree, in the Great Ank, the humerus becomes flattened from side to side, the proximal end is singularly modified, and at the narrow distal end the articular surface for the radius lies completely in front of, and rather above, that for the ulna.

The ulna, which often presents a series of tubercles, indicating the attachment of the secondary quill feathers, is usually a stronger and a longer bone than the radius. There are only two carpal bones, one radial and one ulnar. There is one exception to this, namely, in the Screamer (*Chauna chavaria*), which has three carpals on the left side, the lower arcuate bone having two representatives.

In the *Apterygida* and in the *Casuariida* there is but one complete digit in the manus. It appears to answer to the second of the pentadactyle limb, and is provided with a claw. In the *Struthionida* and *Rheida*, and in all the *Carinata*, there are three digits in the manus, which answer to the pollex and the second and third digits of the pentadactyle fore-limb; and the metacarpal bones of these digits are ankylosed together. As a rule the metacarpal of the pollex is much shorter than the other two; that of the second digit is strong and straight; that of the third is more slender and bowed, so as to leave an interspace between itself and the second, which is often filled up by bony matter. The pollex has two phalanges, and the second of them is, in many birds—*Rhea*, the Screamer, &c.—pointed, curved, and ensheathed in a horny claw. The second digit has two and sometimes three phalanges, as in the Swan; and the terminal phalanx is similarly provided with a claw in sundry birds, e.g., the Swan and *Rhea*. In the Ostrich both the pollex and the second digit are unguiculate. The third digit possesses one phalanx, besides its ankylosed metacarpal, and is always devoid of a claw.

It is a singular circumstance that the relative proportions of the humerus and the manus should present the most marked contrast in two groups of birds which are alike remarkable for their powers of flight. These are the Swifts and Humming-birds, in which the humerus is short and the manus long, and the Albatrosses, in which the humerus is long and the manus relatively short.

In the Penguins the pollex has two free phalanges, and its metacarpal bone (which is distinct in the young birds) ankyloses with that of the second digit. The third metacarpal is slender and straight. The bones of the manus are singularly elongated and flattened.

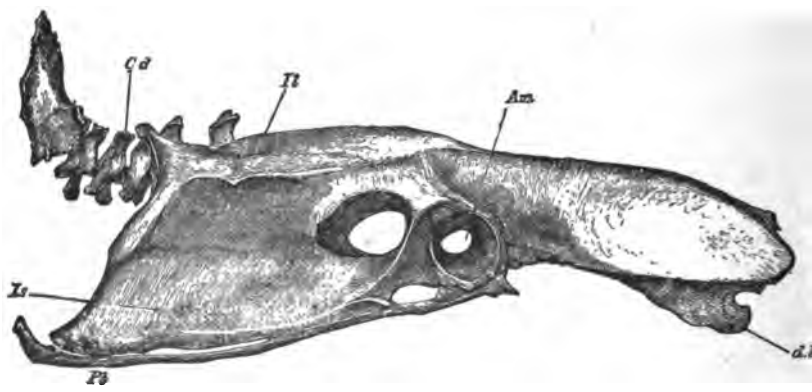

FIG. 34.—Pelvis and caudal vertebrae of adult *Fowl*, side view, natural size. *A*, ilium; *B*, ischium; *C*, pubis; *D*, dorso-lumbar vertebrae; *E*, caudal vertebrae; *Am*, acetabulum.

The *pelvis* of a Bird (fig. 34) is remarkable for the great elongation, both anteriorly and posteriorly, of the iliac bones (*il.*), which unite with the whole length of the edges of the sacrum, and even extend forwards over the

posterior ribs of the dorsal region. Below, each iliac bone forms a wide arch over the acetabulum (*ac.*), the centre of which is always closed by fibrous tissue, so that in the dry skeleton the bottom of the acetabulum is always perforated by a wide foramen. An articular surface on the ilium, on which the great trochanter of the femur plays, is called the *antitrochanter*. In all ordinary birds the ischium (*is.*), which broadens towards its hinder end, extends back nearly parallel with the hinder part of the ilium, and is united with it by ossification posteriorly. The ischiocrotal interval is thus converted into a foramen. The pubis (*pb.*) enters by its dorsal or acetabular end into the formation of the acetabulum, and then passes backwards and downwards as a comparatively slender, curved bone, nearly parallel with the ischium. It is united with its fellow only by fibrous tissue. Very few birds present any important variation from this structure of the pelvis. In *Tinamus*, *Casuarus*, *Dromas*, *Apteryx*, *Dinornis*, the ischium is not united with the backward extension of the ilium by bone. In *Rhea* the ischia unite with one another beneath the vertebral column; and the vertebrae in this region, that is, from the true sacral to the end of the iliac roof, become undistinguishable, being formed into a long slender *uro-sacral* style. In *Struthio* alone, among Birds, do the pubes unite in a median ventral symphysis (see Mivart, *T. Z. S.*, vol. 1 part 7, pp. 434, 435, figs. 72, 73). Another not less remarkable circumstance in the Ostrich is that the 31st to the 35th vertebrae inclusively (counting from the atlas) develop five lateral tuberosities. The three middle tuberosities are large, and abut against the pubis and the ischium. In these vertebrae, as in the dorsal vertebrae of the *Chelonis*, the neural arch of each vertebra shifts forward, so that half its base articulates with the centrum of the next vertebra in front, and the tuberosities in question are outgrowths, partly of the neural arch, and partly of the juxtaposed vertebral centra between which it is wedged. Hence in young Ostriches the face of each tuberosity exhibits a triradiate suture. A small bone is sometimes found on the ventral edge of the pubis, at its middle; this has been supposed to represent a *marcupital* bone (Garrod, *P. Z. S.*, Mar. 1872, p. 359).

The upper articular head of the *femur* is rounded, and its axis is almost at right angles with the body of the bone; a structure which is not found in ordinary *Reptilia*, but exists in the *Iguanodon* and other *Ornithomilida*. The shaft is relatively short and thick, and the two terminal condyles are large and elongated antero-posteriorly. A prominent ridge, which plays between the proximal ends of the tibia and fibula, is apparent upon the posterior and inferior surface of the outer condyle. A similar ridge is faintly developed in some *Lacertilia*, and is well marked in the Dinosaurian *Reptilia*. A patella is usually present but it is some-

times absent, and may be double.

The *fibula* of Birds (fig. 35, *F.*) is always imperfect,

ending in a mere stylo below. Generally, it is decidedly shorter than the tibia, but it has the same length as that bone in some *Pinguina*. The *tibia* (*t.*), or rather "tibiotarsus," is a highly characteristic bone. Its proximal end is expanded, and produced anteriorly, into a great *cnemial* process (which may be variously subdivided), as in *Dinosauria*. The distal end is terminated by a well-marked pulley-like articular surface, which is inclined somewhat forwards as well as downwards. Not unfrequently there is an oblique bar of bone on the anterior face, just above the pulley, beneath which the long extensor tendons pass.

The extremity of the *cnemial* process in *Struthio*, *Rhea*, and *Dromas* is ossified as an *epiphysis*; and in young birds the whole of the distal articular end of the bone is separated from the rest by a suture, and also appears to be an *epiphysis*. But it is, in fact, as Professor Gegenbaur<sup>1</sup> has proved, the proximal division of the tarsus (apparently representing only the *astragalus* of the other *Vertebrata*), which exists in the embryo as a separate cartilage, and, as it ossifies, ankyloses with the tibia. The so-called *tibia* of a bird is therefore, properly speaking, a *tibiotarsus*.

In all Birds, even in *Archaeopteryx*, the fifth digit of the *pes* remains undeveloped;<sup>2</sup> and the second, third, and fourth metatarsals are ankylosed together, and by their proximal ends, with a bone, which is a distinct cartilage in the *fœtus*, and represents the distal division of the tarsus. Thus a *tarsometatarsus* is formed (fig. 37). The distal ends of the metatarsals remain separate, and offer convex articular surfaces to the proximal phalanges of the digits.

In the *Pinguina*, large apertures lie between the several metatarsals of the adult *tarsometatarsus*; and in other birds more or less considerable passages persist between the middle and lateral metatarsals proximally, and the middle and outer distally. In most birds the middle metatarsal does not remain parallel with the others, but its proximal end inclines a little backward, and its distal end a little forward. Hence the two apertures on each side of its proximal end may lie at the bottom of a fossa, or run into one in front, while they remain distinct behind.

Again, in most Birds the posterior face of the proximal end of the middle metatarsal, and the adjacent surface of the tarsal bone, grow out into a process which is commonly, but improperly, termed "calcaneal." The inferior surface of this *hypotarsus* is sometimes simply flattened, sometimes traversed by grooves or canals for the flexor tendons of the digits.

When a *hallux* exists, its metatarsal bone is usually incomplete above, and is united to the ligament by the inner or the posterior surface of the *tarsometatarsus*. In the *Frigate-bird* (*Phaethon*), and in *Statornis*, the *hallucal* metatarsal is remarkably long. The genus *Phaethon* stands alone, as far as we know, in having the *hallucal* metatarsal ankylosed with the others.

In many of the *Alectoromorpha* a spur (*calcar*), con-

sisting of a bony core ensheathed in horn, is developed on the inner side of the metatarsus, and becomes ankylosed with the metatarsal of the second digit; in some there are



Fig. 35.—Right thigh bone of *Fowl*, adult, front view, natural size. U.C., upper condyle; Lc, lower condyle; Lm, trochanter major. The ledge for the *stula* on the outside of the outer lower condyle is not seen in this view.



Fig. 36.—Left tibia and *stula* of a large young *Fowl*, side view. F, *stula*; C.P., *astragalus*; cn., *cnemial* process.



Fig. 37.—*Tarsometatarsal* of a large young *Fowl*, front view, natural size. L.S., tarsal bone; L.M.S., triple *tarsometatarsal* rod, with the first metatarsal seen below on the right hand, but partly out of view on account of its backward position.

two spurs. In a few birds, similar spurs (*Palamedes*), or osseous excrescences (*Pterophaps*), are developed in relation with the metacarpus.

The normal number of the pedal phalanges in Birds is (as in ordinary *Lacertilia*) two, three, four, five, reckoning from the *hallux* to the fourth digit. Among the few Birds which constitute exceptions to the rule are the *Swifts*, in which the third and fourth toe have only three phalanges each (2, 3, 3, 3), and the *Goatsuckers*, in which the fourth toe only has the number reduced (2, 3, 4, 4)—not 2, 3, 4, 3, as Professor Huxley (*op. cit.*) puts it for *Caprimulgus*. Mr Parker has figured the fourth toe of the *Sand-grouse* (*Syrrhaptes*) with only three, but he speaks (*op. cit.*, p. 203) of only one as wanting in that toe.

Many Birds have only three toes by suppression of the *hallux*. In the *Ostrich*, not only the *hallux*, but the phalanges of the second digit, are suppressed, and the distal end of the second metatarsal is reduced to a mere

<sup>1</sup> See "Archiv. für Anat.," in *Phys. Jahrbuch*, 1863, and Huxley, on "Dinosauria," *Q. Jour. Geol. Soc.*, Nov. 10, 1869.

<sup>2</sup> In his earlier papers, Mr Parker mistook the bony core of the *cock's* spur for the first, thus making the proper *hallux* the second toe.

rudiment. Hence the Ostrich has only two toes (which answer to the third and fourth of the pentadactyle foot), with four phalanges in the inner and five in the outer, though the inner toe is far the longer and the stronger.

In most four-toed Birds the hallux is turned more or less completely backwards, and the other three digits forwards. But in many *Acetomorpha* (especially the Owls) the outer toe can be turned outwards, or even backwards, at will. And in the Parrots, Toucans, Cuckoos, Woodpeckers, and other so-called "Scansorial" Birds, the outer toe is permanently reversed. Under these circumstances the distal end of the outer metatarsal may be divided into two distinct articular surfaces. In the Trogons there are two toes in front and two behind, as in the Parrots; but it is the second toe which is turned backwards. Lastly, in the Swifts, the *Dyspormorpha*, and the *Spheniscomorpha*, the hallux is directed more or less forwards, so that all four toes are turned to the front.

As a general rule, the osseous tissue of Birds is remarkably dense and hard. Before hatching, the bones are solid and filled with vascular medulla; but after birth, more or fewer of the bones are always excavated by prolongation of cavities containing air, which lie in their neighbourhood. Such air cavities are always found in the skull, in connection with the nasal and auditory passages, and they may extend through all parts of the skull, with the exception of the jugal arch, which, however, is pneumatic in the Toucan and Hornbill. In many birds, *Apteryx*, Penguin, Divers (and Gulls, according to Professor Huxley; but this is a mistake, their spinal column far into the sacrum is pneumatic; *Larus caesus* shows this well), and the smaller Song-birds, no other bones than those of the skull are pneumatic; but in most birds the air-sacs of the lungs send prolongations into the bones of the rest of the trunk-skeleton, seldom into the caudal vertebrae, as in *Balaniceps*, the Adjutant, Hornbill, &c. In the Hornbills the whole skeleton is pneumatic; in a large number of birds the humerus alone of the limb-bones contains air; in the diurnal *Raptores*, the femur also. It is proper to remark that the amount of pneumaticity of bones by no means follows the development of the powers of flight. In the Ostrich, for example, the bones are far more extensively pneumatic than in the Gull.

In some cases, prolongations of the air-sacs extend beneath the integument.

#### THE MUSCLES.

In the space allotted to the writer, there is scarcely room for justice to be done to one category of organs; and as the skeleton, and especially the skull, is of most direct importance to the zoologist and palaeontologist, and as its form determines, as it were, all other organs, they being correlated with it and answering to it, it seemed to be that on which election should fall for the fuller treatment. An impartial description of all the systems of organs would have resulted in the merest outline for each. For the muscles, Professor Huxley's abstract must serve.<sup>1</sup>

The cutaneous muscles of Birds are well developed, and form broad expansions in various parts of the body. Special

bundles of muscular fibres pass to the great quill feathers of the tail and wings, and others to the *patagium*, a fold of integument which stands between the trunk and brachium behind and between the brachium and ante-brachium in front. In correspondence with the slight mobility of the dorsal vertebrae, the episkeletal and hyposkeletal muscles of the spine attain a considerable development only in the neck and in the tail. Owing to the great size of the sternum, the abdominal muscles are usually small, and the internal oblique may be absent. A diaphragm, consisting of bundles of muscular fibre,<sup>2</sup> which pass from the ribs to the aponeurosis, covering the ventral face of the lungs, is developed in all Birds, but attains to the greatest degree of completeness in the *Bastia*, and especially in *Apteryx*. The muscles of the limbs are remarkably modified by the excessive development of some of those found in other *Vertebrata*, and the suppression of others.

Thus in all birds possessing the power of flight, the *pectoralis major*, the chief agent of the downward stroke of the wing, is very large and thick, taking its origin from the whole length, and a great part of the depth, of the keel of the sternum. The elevation of the wing is chiefly effected by the *pectoralis secundus* (*levator humeri*; or *p. medius*, Macg., plate 3, figs. 4, 5), which arises beneath (*withis* and *over*, in the standing bird) the forewing muscle, and passes over the inner side of the scapulo-coracoid articulation as over a pulley, to reach the humerus. The muscles of the fore-arm and digits are reduced, in accordance with the peculiar modification of the skeleton of these parts. In the hind limb of most birds there is a singular extensor muscle, which arises from the pubis, and ends in a tendon which passes to the outside of the knee-joint and terminates in the leg by uniting with the *flexor digitorum perforatus*. The result of this arrangement is that the toes are flexed whenever the leg is bent upon the thigh, and consequently the roosting bird is held fast upon his perch by the weight of his own body.<sup>3</sup>

#### THE BRAIN.

In Birds, as in Reptiles, the cerebro-spinal axis is angulated at the junction of the spinal cord with the medulla oblongata, the latter being bent down towards the ventral side of the body. The region on which the nerves of the anterior and posterior extremities originate is enlarged in Birds. In the lumbar enlargement the posterior columns of the cord diverge and give rise to the *sinus rhomboidalis*, which is a sort of repetition of the fourth ventricle, the dilated central canal of the spinal cord being covered merely by a thin membrane, consisting chiefly of the ependyma and arachnoid. The brain fills the cavity of the skull, and presents a well-developed cerebellum; a mesencephalon, divided above into two optic lobes; and relatively large proencephalic hemispheres, which attain a considerable size but never conceal the optic lobes. The transverse fissures of the cerebellum are distinct, and the lateral appendages of the cerebellum, or *flocculi*, become well defined, and are wedged, as in many of the lower *Mammalia*, in cavities of the side walls of the skull, arched over by the anterior vertical semicircular canal.

There is no *pons Varolii*, in the sense of transverse fibres connecting the two halves of the cerebellum, visible upon the ventral surface of the mesencephalon. The optic lobes contain ventricles; these are thrown down to the sides of the base of the brain, and are connected over the *aqueductus Sylvii* by a broad commissural band. Each proencephalic lobe contains a lateral ventricle (continuous through the

<sup>1</sup> *Anat. Vert. Anim.*, p. 300. For an almost exhaustive bibliography of writings on the muscular system of birds, see M. Edmond Alix's *Essai sur l'Appareil locomoteur des Oiseaux*, pp. 367-373. This list begins with Aldrovandus, 1581, and ends with Gosse, 1873, 1874. We miss, however, Macgillivray's excellent description, with figures, of the muscles of flight, *Brit. Birds*, vol. I. plate 2, pp. 35-46; and another by Professor Rolleston, "On Muscles connected with the Shoulder-joint," *Trans. Linn. Soc.*, vol. xxvii. pp. 610-629. See also Owen "On the *Apteryx*," *Trans. Zool. Soc.*, vol. vii. p. 281, pl. 46. But the most important work for reference is that of M. Alix himself (*op. cit.*, pp. 373-471, plates 1-3, "Appareil actif de la Locomotion").

<sup>2</sup> See Macgillivray, *Brit. Birds*, vol. II. plate 11, fig. 1, c. c. c.

<sup>3</sup> See J. Alph. Borelli, *De Motu Animalium*, Romæ, 1686-1688, Lugd. Bat. 1865; and *Bibliotheca Anatomica*, Geneva, 1685, plate 62, figs. 4-7.

foramen of Munro with the third ventricle), which is little more than a fissure between the very thin inner wall of the lobe and its thick outer part, which contains the corpus striatum. The corpora striata are united by an anterior commissure, which is not of large size. The thinning of the inner wall of the lobes, from the margin of the foramen of Munro backwards, which gives rise to the fissure of Bichat in the *Mammalia*, extends for a very short distance in the *Sauropsida*, even in Birds. The olfactory lobes are usually elongated, and contain ventricles continuous with those of the prosencephalic hemispheres. In all the *Sauropsida* the motor nerves of the tongue pass through a foramen in the occipital bone. Hence twelve pairs of cranial nerves are present, except in the *Ophidia*, which possess no spinal accessory nerves. The lateral cutaneous branches, so generally sent to the trunk by the pneumogastric in the *Ichthyopsida*, are absent, but the pneumogastric gives a recurrent branch to the larynx. The third, fourth, and sixth nerves arise quite independently of the fifth. The sympathetic is well developed.<sup>1</sup>

#### ORGANS OF SENSE.

Birds possess nasal glands, which attain a large size, and lie more usually upon the frontal bone, or in the orbits, than in the nasal cavity. In the Snakes and Lizards these bones lie between the septo-maxillaries above and the vomers below. In Birds, wherever placed, the duct opens near the same region as in the Reptiles. In many kinds, especially Passerines, the bones that should cover them are really present, but are rudimentary and attached to the vomer. These are the septo-maxillaries.

The eye in many Birds, as in the extinct *Ichthyosaurus*, attains very great absolute and relative dimensions. Birds possess, like many Reptiles, a nictitating membrane.<sup>2</sup> In the Lizards a short, thick muscle (*bursalis*) is attached to the inner and posterior wall of the orbit, and ends in a fibrous sheath. A tendon, one end of which is attached to the presphenoidal region of the inner wall of the orbit, passes backwards through the sheath, and then forwards, to be attached to the nictitating membrane. When the muscle contracts, it necessarily pulls the latter over the eye. A Harderian gland is always developed, and a lachrymal gland very generally, but not always. In the *Chelonia*, muscular fibres (forming the so-called *pyramidalis* muscle) arise from the inner side of the eyeball, and, arching over it at the optic nerve, are inserted partly into the outer edge of the nictitating membrane, partly into the lower eyelid. The *Crocodylia* have a *pyramidalis* muscle taking the same origin and course; but it sends no fibres to the lower eyelid, its tendon being inserted altogether into the nictitating membrane. The third arrangement, which in a manner brings together the first and the second, is that seen in Birds. A *pyramidalis* muscle, arising from the inner and under surface of the eyeball, soon ends in a tendon which sweeps round the upper and outer surfaces of the sclerotic to the nictitating membrane, as in the *Crocodylia*. But there is also a *bursalis* muscle, which however arises, not, as in Lizards, from the wall of the orbit, but from the upper surface of the sclerotic itself,

whence it passes backwards and ends in a fibrous sheath which encloses the tendon of the *pyramidalis*. The contraction of the muscle necessarily tends to draw the tendon of the *pyramidalis* away from the optic nerve. A tubercle is sometimes developed from the sclerotic above the entrance of the optic nerve, and prevents the tendon of the *pyramidalis* from shifting forwards and inwards. The eyeball is always turned by four *recti* and two *obliqui* muscles. The superior oblique does not pass over a pulley. The *Chelonia* and most *Lacertilia* have a more or less completely developed retractor or choanoid muscle. A ring formed of bony plates is developed in the fore-part of the sclerotic in *Lacertilia*, *Chelonia*, *Ichthyosaurus*, *Dicynodontia*, *Pterosauria*, and *Aves*; but not in *Ophidia*, *Plasiosauria*, or *Crocodylia*. The iris and *tensor choroidae* contain striated muscular fibres. A pecten is very generally developed. It attains a large size, and becomes much plaited in *Aves*. Even in Birds, the sclerotic is cartilaginous. In the organs of hearing, also, the Bird is best studied as a culmination of the *Sauropsida*.

Only *Crocodylia* and *Aves* possess a rudiment of an external ear. The *Ophidia* and the *Amphibanoidea* have no tympanic cavity. In some *Chelonia*, in *Sphenodon*, and in the Chameleons, the tympanic membrane is covered by integument, but a tympanic cavity exists. In *Lacertilia* the tympanic cavities communicate by wide openings with the pharynx; but in *Chelonia*, *Crocodylia*, and *Aves*, the communicating passages, reduced in size, become eustachian tubes. In the *Chelonia* these curve backwards, downwards, and inwards, round the quadrate bones, and open separately on the roof of the mouth. In the *Crocodylia* there are three eustachian tubes—one median, and two lateral. In *Aves* there is but one eustachian aperture, answering to the median of the *Crocodylia*; and, as in the latter group, each eustachian tube usually traverses the osseous base of the skull to join its fellow in the common aperture.

The stapes is a columelliform bone, the outer end of which is attached to the tympanic membrane when the latter is developed, but lies among the muscles when there is no tympanic cavity (Snakes and *Amphibana*). All *Sauropsida* possess a *femora rotunda*, as well as a *femora ovalis*; and all have a cochlea, which is never coiled spirally, and is more rudimentary in the *Chelonia* than in other groups. Three semicircular canals, an anterior and a posterior vertical and an external horizontal, are connected with the membranous vestibule. In *Aves*, the anterior vertical canal is very large in proportion to the others, and the adjacent crura of the two vertical canals overlap before they unite with one another.<sup>3</sup>

#### ALIMENTARY ORGANS.

Well-developed sub-lingual, sub-maxillary, and parotid glands appear in Birds, and the sub-lingual glands attain an immense size in the Woodpeckers (Macg., *Brit. Birds*, vol. iii. plate 15). The tongue varies greatly, being sometimes obsolete (as in the Crocodile). It is small in the *Totipalmata* and in *Balaniceps*. It is generally sagittiform and papillate at the base; but it is thick, and even serrated in the *Rapaces* (Macg., *Brit. Birds*, vol. iii. plates 19, 20). In the *Picidae* (*op. cit.*, plate 15), where the hyoid bones are extremely elongated and the tongue prehensile to a marvellous degree, the true lingual part is a small arrow-head, covered with a prickly, horny sheath—these prickles are reverted, like a Snake's teeth.

The alimentary canal of Birds may have several dilata-

<sup>1</sup> See Owen, Art. "Aves," *Cyclop. Anat. Phys.*, pp. 298, 299; Macgillivray, *Brit. Birds*, vol. i. p. 48, and vol. iii. plate 18; Owen "On Brain of *Apteryx*," *Trans. Zool. Soc.*, vol. vii. plates 45 and 46, p. 281. For the development of the Fowl's brain, see Foster and Balfour's *Elem. of Embryology*; see also Huxley, *Anat. Vert. Anim.*, p. 201, fig. 90, 91.

<sup>2</sup> See Macgillivray, *Brit. Birds*, vol. iii., plate 17, p. 146, for excellent figures and descriptions of the Bird's eye; also Owen, article "Aves," *Cyclop. Anat. and Phys.*, p. 208. For its development, Foster and Balfour's work, p. 97. The Bird's eye being a more highly specialized *Reptilian* organ, its condition in the lower types of the *Sauropsida* is also given in the text.

<sup>3</sup> See Macgillivray, *Brit. Birds*, vol. iii. plate 18, figs. 2 and 3, p. 156; Owen, article "Aves," in *Cyclop. Anat. and Phys.*, p. 208, fig. 141. For development, see Foster and Balfour's work, p. 111; Huxley on "Iacus and Stapes," p. 208; and Parker, *op. cit.*

tions above the intestine; the latter is divisible into small and large, and the last always terminates in a cloaca. It is invested by a peritoneal coat, which follows the curvatures of the intestine. In most Birds, as in the Crocodiles, the pyloric and cardiac apertures are approximated. In many *Crocodylia* and *Aves* (e.g., *Ardeida*) there is a pyloric dilatation before the commencement of the duodenum. In the *Alectoromorpha*, in Eagles and Hawks amongst the *Aptomorpha*, and in Pigeons, the oesophagus is enlarged into a "crop." In the latter it is bilobate and symmetrical (Macg., *op. cit.*, vol. i. plate 7).

In the *Crocodylia* and in *Aves* the walls of the stomach are very muscular, and the muscular fibres of each side radiate from a central tendon or aponeurosis. The thickening of the muscular tissue of the stomach attains its maximum in the Graminivorous Birds; and it is accompanied by the development of the epithelium into a dense and hard coat, adapted for crushing the food of these animals. Birds commonly aid the triturating power of this gastric mill by swallowing stones; but the habit is not confined to them, Crocodiles having been observed to do the same thing.<sup>1</sup> Birds are further remarkable for the development of a broad series of glands in the lower part of the oesophagus, which is usually dilated, and forms a proventriculus, connected by a narrow neck with the gizzard (*gigerium*). In *Sula alba* and *Phalacrocorax carbo*, the writer, long ago, saw this zone to be imperfect. In these birds the gullet is very capacious from the pharynx downwards, but the proventriculus is still more so,—it is a large "paunch."

Some *Ophidia* have a cecum at the junction of the small intestine with the large; and two such caeca, which sometimes attain a large size, are generally developed in *Aves*. In this class, also, the small intestine not unfrequently presents a caecal appendage, the remains of the vitelline duct. The writer's drawings show this in *Gallinula chloropus*, *Ardea cinerea*, and *Colymbus septentrionalis*. The duodenum of Birds constantly makes a loop, within which the pancreas lies, as in the *Mammalia*.

The liver in the *Sauropsida* almost always possesses a gall bladder, which is usually attached to the under surface of the right lobe, but in *Ophidia* is removed to some distance from it.

A peculiar glandular sac, the *bursa Fabricii*, opens into the anterior and dorsal region of the cloaca in Birds.<sup>2</sup>

#### THE HEART.

In Birds, the venous and arterial blood currents communicate only in the pulmonary and systemic capillaries. The auricular and ventricular septa are complete (see Owen, "Aves," p. 330), as in the *Crocodylia*; but the right ventricle only gives off the pulmonary artery, the left aortic arch has disappeared, and the right arch (the 4th of that side in the embryo) becomes the most important of all the arches. The septum of the *caecum pulmonale* becomes a great muscular fold, and takes on the function of an auriculo-ventricular valve. At the origin of the pulmonary artery, and at that of the aortic arch, three semilunar valves are developed

In *Aves* there is no renal portal system, and the anterior abdominal vein opens into the inferior vena cava, close to the heart. Nevertheless, a median trunk, which is given off from the caudal vein, carries a considerable proportion of its blood directly into the hepatic portal system. The pericardium of the Bird is thin, but of a firm texture, and adheres by its external surface to the surrounding air-cells. (Owen, "Aves," p. 330.)

#### RESPIRATORY AND VOCAL ORGANS.<sup>3</sup>

"In Birds there are distinct thyroid, cricoid, and arytenoid cartilages, which may be more or less completely ossified. Sometimes an epiglottis is added.<sup>4</sup> The voice of Birds, however, is not formed in the larynx, but in the *syrix* or lower larynx, which may be developed in three positions:—1. At the bottom of the trachea, from the trachea alone; 2. At the junction of the trachea and bronchi, and out of both; 3. In the bronchi alone. The *syrix* may be altogether absent, as in the *Rallies* and the *Cathartidae* or American Vulture. The commonest form of *syrix* is the second mentioned above, or the *broncho-tracheal syrix*. It is to be met with in all our common Song Birds, but is also completely developed in many Birds, such as the Crows, which have no song. In its commonest condition this form of *syrix* presents the following characters: The hindmost rings of the trachea coalesce, and form a peculiarly formed chamber, the *tympaenum*. Immediately beyond this the bronchi diverge, and from their posterior wall, where one bronchus passes into the other, a vertical fold of the lining membrane rises in the middle line towards the tympaenum, and forms a vertical *septum* between the anterior apertures of the two bronchi. The anterior edge of this septum is a free and thin *membrana semilunaris*, but in its interior a cartilaginous or osseous frame is developed, and becomes united with the tympaenum. The base of the frame is broad, and sends out two cornua, one along the ventral, and the other along the dorsal edge of the inner wall of the bronchus of its side, which in this part of its extent is membranous and elastic, and receives the name of the *membrana tympanoformis interna*.

"The bronchial 'rings' opposite this are necessarily incomplete internally, and have the form of arches embracing the outer society of the bronchus. The second and third of these bronchial arches are freely movable, and elastic tissue accumulated upon their inner surfaces gives rise to a fold of the mucous membrane, which forms the outer boundary of a cleft, bounded on the inner side by the *membrana semilunaris*.

"The air forced through these two clefts from the lungs sets these elastic margins vibrating, and thus gives rise to a musical note, the character of which is chiefly determined by the tension of the elastic margins and the length of the tracheal column of air. The muscles, by the contraction of which these two factors of the voice are modified, are extrinsic and intrinsic. The former are possessed by Birds in general, and are usually two pairs, passing from the trachea to the furcula and to the sternum (Macg., vol. ii. plate 13, fig. 8, d. d., s. s.; and vol. iii. plate 15, s. s., s. s.). Some Birds possessing a broncho-tracheal *syrix* such as has been described, as the *Alectoromorpha* (see Macg., vol. ii. plate 13, fig. 8, f.), *Cathartomorpha*, and *Dysporomorpha*, have no intrinsic muscles. Most others have one pair, attached on one side to the rings of the trachea above, and to the tympaenum, or the proximal bronchial arch below (Macg., vol. ii. plate 13, figs. 1, 2; and vol. iii. plate 19). The majority of the *Cornucomorpha* (Macg., vol. ii. plates 10, 11) have five or six pairs of intrinsic syringeal muscles, which pass from the trachea and its tympaenum to the movable bronchial arch.<sup>5</sup> The Parrots have no septum, and only three pairs of intrinsic muscles.

"The *tracheal syrix* only occurs in some American *Cornucomorpha*. The hinder end of the trachea is flattened, and six or seven of its rings above the last are interrupted at the sides, and held together by a longitudinal ligamentous band. These rings are excessively delicate, so that the part of the trachea is in great part membranous. The *bronchial syrix* occurs only in *Steatornis* and *Orotorhynchus*.

<sup>1</sup> We shall here give Professor Huxley's excellent abstract of what is known upon this subject up to this time; but the reader is referred to Job. Müller's work, "Researches on the Comparative Anatomy of the Vocal Organs of Birds," *Berlin Acad.*, June 1844, and *Ann. Mag. N. H.*, vol. xvii. p. 499. Macgillivray has many excellent illustrations and descriptions of these parts; and the writer followed his step by step many years ago.

<sup>2</sup> For a clear description of the exquisite structure of the tracheal rings in Birds, see Macg., vol. ii. p. 34. They are often thoroughly ossified, and are notched above and below, both before and behind; and alternate ridges allow a marvellous amount of overlapping, the edge being well bevelled; each ring is an ellipse.

<sup>3</sup> Macgillivray (*op. cit.*, vol. ii. pp. 26, 28) was afraid to be thought overrating the number of these intrinsic muscles. He understated them, not thoroughly making out their divisional lines.

<sup>1</sup> See Sir S. Baker's *Zoologia*, vol. 1. p. 295. "The stomach contained about five pounds' weight of pebbles (in a Crocodile 12 feet 3 inches long in its entire length), as though it had fed upon flesh resting upon a gravel bank, and had swallowed the pebbles that adhered." This intrepid traveller seems to be unaware that the Crocodile has a strong gizzard.

<sup>2</sup> Besides copious unpublished materials on this subject from his own dissections, the writer is largely indebted to Macgillivray's most valuable work, so full of illustrations of the digestive organs of Birds; also to Prof. Owen's article "Aves" (*op. cit.*); to Prof. Huxley he owes form and order. For the development of these parts the reader is still directed to Foster and Balfour's work, as also of the parts yet to be described.

"In the genus *Oligotus*, among the *Chalonia*, and in some species of *Graculus* (*G. acutus*, e.g.), the trachea is bent upon itself. Similar flexures attain an extraordinary development in many Birds, and may lie outside the thorax under the integument (*Trogon erythellus*, some species of *Oreax* and *Penelope*); in the cavity of the thorax (some Spoonbills); under the body of the sternum, in a large chamber hollowed out of the keel (some Swans and Cranes); even in a sort of cup formed by the median process of the furcula (*Nucifraga cristata*). In the Emu some of the rings of the trachea are incomplete in front, and bound the aperture of an air-sac which lies in front of the trachea. Some Birds (*Aptenodytes*, *Procellaria*) have the trachea divided by a longitudinal septum, as in *Sphyrula* among the *Chalonia*. The tracheal tympanum is greatly enlarged in *Cephalopterus*, and in many Ducks, Geese, and Divers; and in these aquatic birds the enlargement is more marked in the male, and is usually symmetrical, the left side being generally the larger.

"In *Accipiter* the lungs are firmly fixed on each side of the vertebral column, the dorsal surface of each lung being moulded to the superjacent vertebrae and ribs. The muscular fibres of the diaphragm arise from the ribs outside the margins of the lungs, and form the vertebral column, and end in an spongy mass upon the ventral surface of the lungs. Each bronchus enters its lung nearer the centre than the anterior edge, and, immediately losing its cartilaginous or bony rings, dilates, and then traverses the lung, gradually narrowing to the posterior edge of that viscus, where it terminates by opening into the posterior air-sac, which generally lies in the abdomen. From the inner side of the bronchus canals are given off, one near its distal end, and others near its entrance into the lung, which pass directly to the ventral surface of the lung, and there open into other air-sacs. Of these there are four. Two, the *anterior* and the *posterior thoracic*, lie in the ventral face of the lung in the thorax. The other two are situated in front of its anterior end, and are *extra-thoracic*. The external and superior is the *cervical*; the internal and inferior the *inter-clavicular* (Macg., vol. II., p. 17, fig. 107). This last unites into one cavity with its fellow of the opposite lung. Thus there are altogether nine air-sacs; two posterior or abdominal, four thoracic, two cervical, and one inter-clavicular. Other large canals given off from the bronchus do not end in air-sacs, but these which pass from the inner side of the bronchus run along the ventral surface, and those on the outer side along the dorsal surface of the lung. Here they give off at right angles a series of secondary canals, and these similarly emit still smaller tertiary canals, and thus the whole substance of the lung becomes inter-penetrated by tubuli, the walls of the finest of which are minutely sacculated. The different systems of tubuli are placed in communication by perforations in their walls. In most birds these air-sacs (except the anterior and posterior thoracic, which never communicate with any cavity but that of the lungs) are in communication with a more or less extensively ramified system of air passages, which may extend through a great many of the bones, and even give off subcutaneous sacs. Thus the inter-clavicular air-sac generally sends a prolongation into each axilla, which opens into the proximal end of the humerus, and causes the cavity of that bone to be full of air. When the sternum, the ribs, and the bones of the pectoral girdle are pneumatic, they also receive their air from the inter-clavicular air-sacs. The cervical air-sacs may send prolongations along the vertebral canal of each side; which supply the bodies of the cervical vertebrae, and communicate with elongated air-chambers in the spinal canal itself. When the dorsal vertebrae are pneumatic they communicate with the system of the cervical air-sacs. The abdominal air-sacs send prolongations above the kidneys to the sacral vertebrae and to the femora, whence these bones, when they are pneumatic, receive their air. The pulmonary air-sacs and their prolongations do not communicate with the air cavities of the skull, which receive their air from the tympana and the nasal chambers. In some Birds (*Passerina*) the air is conducted from the tympanum to the articular piece of the mandible by a special bony tube, the *stiphiotubum* [the largest of the tympanic chain, and having the general anatomical relations of the Ichthyic 'interopercular.']

#### RENAL AND REPRODUCTIVE ORGANS.

The kidneys of Birds are composed of a number of lobules of unequal sizes, and these are packed in the concavities of the pelvis, in the same manner as the lungs are packed in the regular intercostal spaces of the upper part of the thorax. The ureters, as in the Reptiles, open directly into the cloaca; but there is no urinary bladder. The *ductus Fabricii* opens into the cloaca above its hinder part.

The testes lie on each side the foremost lobes of the kidneys. They are very small in mid-winter, and largest by the middle of April. In the embryo Bird there are two

oviducts. "The duct of Müller on the right side (that on the left side with the corresponding ovary generally disappearing) remains in the female as the oviduct. In the male it is almost entirely obliterated on both sides" (Foster and Balfour, p. 168).

#### INTEGUMENT AND FEATHERS.<sup>1</sup>

"The exoskeleton of Birds consists almost entirely of epidermic structures in the form of horny sheaths, scales, plates, or feathers. No Bird possesses dermal ossifications, unless the spurs, which are developed upon the legs and wings of some species, may be regarded as such.

The feathers are of various kinds. Those which exhibit the most complicated structure are called *pennae*, or *contour feathers*, because they lie on the surface and determine the contour of the body. In every penna the following parts are to be distinguished:—a main stem (*scapus*) forming the axis of the feather, and divided into a proximal hollow cylinder, partly imbedded in a sac of the derm, called the *calamus*, or quill; and a distal *vexillum*, or vane, consisting of a four-sided solid shaft, the *rachis*, which extends to the extremity of the feather, and bears a number of lateral processes, the *barbs*. The calamus has an inferior aperture (*umbilicus inferior*), into which the vascular pulp penetrates, and a superior aperture (*umbilicus superior*), situated on the under surface of the feather at the junction of the calamus with the scapus. The barbs are narrow plates, tapering to points at their free ends, and attached by their bases on each side of the rachis. The edges of these barbs are directed upwards and downwards, when the *vexillum* of the feather is horizontal. The interstices between the barbs are filled up by the *barbules*,—pointed processes, which stand in the same relation to the barbs as the barbs do to the rachis. The barbules themselves may be laterally serrated and terminated by little hooks, which interlock with the hooks of the opposed barbules. In very many Birds each quill bears two *vaxilla*; the second, called the *after-shaft* (*Agpro-rachis*), being attached on the underside of the first close to the superior umbilicus. The after-shaft is generally much smaller than the chief *vaxillum*; but in some Birds, as the *Cassariida*, the two are of equal size, or nearly so. Muscles pass from the adjacent integuments to the feather sac, and by their contraction erect the feather. The other kinds of feathers differ from the *pennae*, in having the barbs soft and free from one another, when they constitute *penaculium*, or *plumula* (down), according as the scapus is much or little developed. When the scapus is very long, and the *vexillum* very small or rudimentary, the feather is termed a *filopluma*.

The contour feathers are distributed evenly over the body only in a few Birds, as the *Ratites*, the Penguins, and some others. Generally, the *pennae* are arranged in definitely circumscribed patches or bands, between which the integument is either bare or covered only with down. These series of contour feathers are termed *pteryla*, and their interspaces *apteria*.

In some Birds, such as the Herons, plumule of a peculiar kind, the summits of which break off into a fine dust or powder as fast as they are formed, are developed upon certain portions of the integument, which are termed *powder-down patches*.<sup>2</sup>

<sup>1</sup> This abstract is taken (by the author's permission) from Professor Huxley's *Anatomy of Vertebrate Animals*, pp. 274, 275. For a full account of these structures, see Nitzsch's *Pterylography*, translated from the German by Dr P. L. Solater, F.R.S., Ray Soc., 1867.

<sup>2</sup> See Bartlett, "On the Balmoepe," *Proc. Zool. Soc.*, March 26, 1861, pp. 1-4; and Murie "On the Dermal and Visceral Structures of the Kagu, *Struthio*, and Boat-Bill," *Trans. Zool. Soc.*, 1871, plate 56, pp. 465-492; in this valuable paper the *powder-down patches* are also shown in *Podiceps* and *Cuculus*.

The integument of Birds is, for the most part, devoid of glands; but many Birds have a peculiar sebaceous gland developed in the integument which covers the coccyx. This *wropygial gland* secretes an oily fluid, which the Bird spreads over its feathers by the operation of "preening." The excretion passes out by one or two apertures, commonly situated upon an elevation, which may or may not be provided with a special circlet of feathers.

In various Birds (e.g., the Turkey) the integument about the head and neck develops highly vascular and sometimes erectile processes (*combs, wattles*).

Within the extremely narrow space of an article like the present, the merest abstract of most of our present ornithological knowledge can be given. A mere list of the published works on the subject would fill most of the space allotted to the writer. We will conclude by giving Professor Huxley's masterly comparison of the Bird class and that of the Reptiles below with the Mammalia above them (see *Proc. Zool. Soc.*, April 11, 1867). The writer has modified some assertions from later papers by the same author:—

"That the association of Birds with Reptiles into one primary group of the *Vertebrata*, the *Sauropsida*, is not a mere fancy, but that the necessity of such a step is as plain and demonstrable as any position of taxonomy can be, appears to me to be proved by an enumeration of the principal points in which *Aves* and *Reptiles* agree with one another and differ from the Mammalia.

- "1. They are devoid of hair.
- "2. The centra of their vertebrae have no epiphyses.
- "3. Their skulls have single occipital condyles.
- "4. The prootic bone either remains distinct throughout life, or unites with the epiotic and opisthotic *after* these have become ankylosed with the supra-occipital and exoccipital.
- "5. The *malleus* is not subservient to the function of hearing, as [one of the] *ossicula auditus*.
- "6. The mandible is connected with the skull by the intermedial of a quadrate bone [which represents the upper bulbous part, with the 'manubrium' of the *malleus* of Mammalia].
- "7. Each ramus of the mandible is composed of a number of separate ossifications, which may amount to as many as six in all. (Of these the *articularis* represents the [antero-inferior part of the] *malleus* of Mammalia).
- "8. The apparent 'ankle-joint' is situated not between the *tibia* and the *astragalus*, as in the Mammalia, but between the proximal and distal divisions of the tarsus.<sup>1</sup>
- "9. The brain is devoid of any *corpus callosum*.
- "10. The heart is usually provided with two aortic arches; if only one remains, it is the right.
- "11. The red blood-corpuscles are oval and nucleated.
- "12. The cavities of the thorax and abdomen are never separated by a complete diaphragm.
- "13. The allantois, which is highly vascular, is very large, and envelops the embryo; but no villi for placental connection with the parent are developed upon it.
- "14. There are no mammary glands."

(W. K. P.)

#### FOSSIL BIRDS.

Footprints, or casts of footprints, at the time of their discovery and long afterwards supposed to be those of Birds, were found about the year 1835 in the Triassic formation of the valley of the Connecticut in New England, and were described by Messrs Deane and Marsh. Subsequently Professor Hitchcock and Mr Warren contributed to the elucidation of these tracks, which were ascribed to various genera of the Class that received the names of *Amblonges*, *Argosom*, *Brontosom*, *Grallator*, *Ornithopus*, *Platyspterna*, *Tridentipes*, and others. No portion of any of the animals to which these traces are due seems to have been met with,<sup>2</sup>

<sup>1</sup> See Gegenbaur, *Archiv für Anatomie* (1863), and *Untersuchungen zur vergleichenden Anatomie* (1864).

<sup>2</sup> The only known bones from this deposit were exhibited by Professor W. B. Rogers at the meeting of the British Association in Bath (*Rep. Br. Ass. 1864, Trans. Sect.*, p. 66).

and the best American palaeontologists are now inclined to attribute them rather to Dinosaurian Reptiles than to Birds. Whatever may be thought of the rest, it appears most likely that the creatures designated as *Platyspterna* and *Tridentipes* were certainly not ornithic. *Brontosom* must have been a colossal animal, its footprint measuring about 16½ inches in length and its stride some 8 feet.

An enormous space of time separates these reputed Ornithichnites, as they are called, from the first undoubted fossil Bird. This was discovered in 1861 by Andreas Wagner in the lithographic slate of Solenhofen in Bavaria, belonging to the Oolitic series, and is commonly known by the name of *Archæopteryx*,<sup>3</sup> though that of *Gryphocœurus*



FIG. 28.—Slab containing remains of *Archæopteryx*, from the original in the British Museum. Reduced.

was given by its original describer to the at present unique specimen now in the British Museum. Unfortunately deficient in some very important parts—such as the head and nearly all the sternal apparatus—it has others in excellent preservation. It was about the size of a Rook (*Corvus frugilegus*), and along with the greater portion of the skeleton, impressions of many of its feathers, particularly the quills, are plainly visible. Its most obvious peculiarity is the presence of a long Lizard-like tail, composed of twenty vertebrae; but from each of these springs a pair of well-developed rectrices. A scarcely less remarkable feature is that afforded by the extremity of the wings, where it would appear that there was a free digit answering to the *pollex*. The many Reptilian characters of this wonderful creature cannot be noticed in this treatise, though their value must be fully admitted; but since the appearance of Professor Owen's description of the specimen (*Phil. Trans.* 1863, p. 33), nobody has hesitated to receive it as a true Bird, though one which exhibits an extraordinary dissimilarity from all other known members of the Class. To make any suggestion as to the more immediate affinities and habits of *Archæopteryx* were vain. It at present

<sup>3</sup> Herr Hermann von Meyer had previously described a fossil feather from the same formation, to the owner of which he gave this name. Its specific, generic, not to say ordinal, identity with the creature whose remains were subsequently found is of course problematical, but the received laws of nomenclature fully justify the common usage.



stands alone, and as that can be said in the latter respect is, that the form of its feet indicates a bird given to a more or less arboreal life. It is not easy to imagine the use in

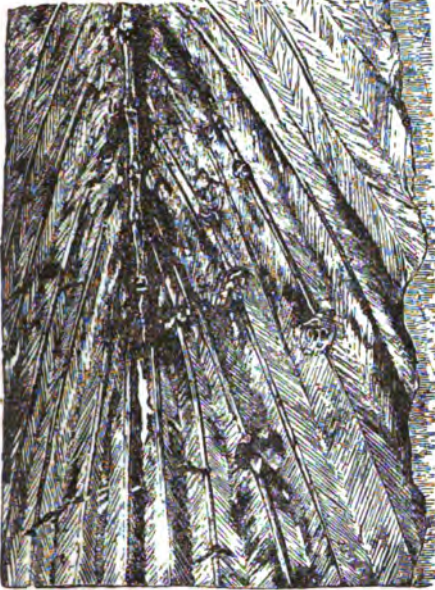

FIG. 39.—Portion of the slab containing remains of *Archaeopteryx*, showing the extremity of the tail, with a pair of feathers springing from each vertebra. Natural size.

the bearer's economy of its singular tail, which one would think must have been a clumsy appendage, and this notion is perhaps justified by the certainty that similar tails had gone out of fashion when the next birds known to have existed flourished.

These are from the Cretaceous formation, and as in that freshwater-deposits are few in number, it is not surprising that true ornithic remains are in them exceedingly rare. Many fossils that were formerly thought to have been the remains of Birds have since been determined as belonging to Reptiles (*Pterodactyls*),—among them the *Cimoliornis diomedea*, from the Chalk of Maidstone, which Dr Bowerbank has not hesitated to refer to his *Pterodactylus gigantus*. But in 1858 Barrett discovered, in the Upper Greensand of Cambridge, remains described by Mr Seeley in 1866 (*Ann. and Mag. Nat. Hist.* ser. 3, xviii. p. 100) under the name of *Pelagornis barretti*,—which, we must bear in mind, has nothing to do with the genus *Pelagornis* established by M. Lartet (*Comptes Rendus*, 1857, p. 740),—and these remains, renamed *Enantiornis* in 1869 by Mr Seeley (*Index to Rep. on Second. Reptiles, &c.*), seem to be those of a real Bird, having some resemblance to a Penguin. Belonging to the same epoch also Bird-fossils have been found by Professor Marsh in the United States of America, and they have been referred to at least six genera—*Apatornis*, *Graculavus* (4 spp.), *Hesperornis*, *Ichthyornis*, *Laornis*, *Palaeotringa* (3 spp.), and *Telmatornis* (3 spp.). The first and fourth of these were about as large as a Pigeon, or larger, are from the Cretaceous shale of Kansas, and differ from all known Birds in having biconcave vertebrae and, possibly, teeth, whence the latter has been made the type of a distinct Subclass, to which the name of *Odontornithes* is applied. The second belongs to the *Stegonopodes*; the third seems to have been related to the *Colymbida*. The affinities of the

fifth have not yet been determined; it was nearly as large as a Swan, and its remains were discovered in the Middle Marl of New Jersey. The sixth was apparently one of the *Limicolæ*; and the seventh was probably allied to the *Balliida*.

The Eocene period furnished a still greater number of ornitholites. First, perhaps, in bulk is that known as *Gastornis parisiensis*, found by M. Gaston Planté, and soon after by M. Hébert, in a conglomerate beneath the Plastic Clay of Bas-Meudon. Much difference of opinion obtains as to the affinities of this Bird, which was at least as large as an Ostrich; but M. Alphonse Milne-Edwards,<sup>1</sup> after reviewing the evidence of others and studying the specimens obtained, considers it (*Dict. Univ. & Hist. Nat.* ed. 2, May 1869) most nearly allied to the *Anatida*, from which, however, it differs in so many important characters that it cannot be included among them according to any taxonomic scheme as yet proposed. One may presume, he adds, that it was incapable of flight, though able to swim. Other birds of huge stature lived at a time not much later. Dr Bowerbank has referred the fragment of a tibia from Sheppey, which was a little smaller than that of an Emu, to a genus *Lithornis*. On this Mr Seeley has founded his *Megalornis*, the *Lithornis* to which Professor Owen, in 1841, had applied the former name, being regarded as resembling a Vulture. This naturalist has also described the fragmentary cranium of a large Bird, combining Dinornithic and Struthious characters, from the same locality, under the name of *Dasornis* (*Tr. Zool. Soc.* vii. p. 145), and he has further added from Sheppey (*Quart. Journ. Geol. Soc.* xxix. p. 511) a yet more remarkable form to those previously known from Britain, in the *Odontopteryx tolisapiens*—



FIG. 40.—Remains of head of *Odontopteryx*, from the original in the British Museum; side view; natural size.

a creature having its jaws armed with osseous denticulations, and in this respect unlike Professor Marsh's *Ichthyornis*,



FIG. 41.—Remains of head of *Odontopteryx*, seen from above.

concluding that it was a warm-blooded, feathered, and winged biped, web-footed, and a fish-eater. From Sheppey,

<sup>1</sup> The writer cannot name this distinguished naturalist without acknowledging the very many tokens of friendship received at his hands in connection with the present subject, while the summary of fossil ornithology here given is in a great measure due to the article cited in the text a few lines further on. Further details are taken from his magnificent *Recherches Anatomiques et Paléontologiques pour servir à l'histoire des Oiseaux Fossiles de la France, Paris, 1867-71*. The writer has also to express his thanks to Mr Seeley for valuable assistance in this portion of the article.

too, were long ago detected portions of a Kingfisher (*Haleyon*), and a bird allied to the Gulls or Terns (*Larida*), while a continuation of the same formation at Highgate has supplied a sternum which has been referred to the Herons (*Ardeida*). The freshwater beds at Hempstead, in the Isle of Wight, have furnished remains called by Mr Seeley (*Ann. and Mag. Nat. Hist.* ser. 3, xviii. p. 109) *Ptenornis*—a form of doubtful affinity; and that paleontologist has described from those of Hordwell a tibia, apparently Struthions, under the name of *Macrornis*. In the schist of Plattenberg at Glarus a nearly complete skeleton, perhaps belonging to the *Passeres*, was discovered, and called by Von Meyer *Protornis* (since renamed by Professor Gervais *Osteornis*), and other undetermined fragments of birds' bones, with impressions of their feathers, have been found in several beds of about the same age in France.

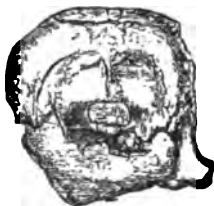

FIG. 42.—Remains of head of *Osteornis*, seen from behind.

The fossils of the Paris Basin and its coeval deposits deserve, however, fuller notice. First brought to light at Montmartre towards the end of the last century, many of the remains fell under the notice of Cuvier, and were by him determined in a manner more or less exact. Following his investigations, the labours of MM. Gervais, Blanchard, and Deshayes considerably added to our knowledge of these ornitholites, till finally M. Alphonse Milne-Edwards, having carefully gone over all the specimens discovered, refers them to the genera *Agnopteris*, *Cormoranus* (i.e., *Phalacrocorax*), *Coturnis* (3 spp.), *Falco*, *Gypcornis*, *Leptosomus* (a form now only known from Madagascar), *Limosa*, *Palaeocircus*, *Palaeortyx*, *Peisidna*, *Rallus*, *Sitta*, and *Tringa* (?). Of these are extinct the first, which seems to have been in some measure allied to the Flamingoes (*Phanicopterida*); the fifth, a Ralline form; and the eighth and ninth, belonging to the diurnal Birds-of-prey and the *Gallina* respectively. The footprints of at least seven more species of birds have also been recognised in the same beds, so famed for the remains of *Anoplotherium*, *Palaeotherium*, and their contemporaries, which were resuscitated by the great Cuvier. The marl-beds of Aix in Provence, belonging to this epoch, have yielded fossil eggs and feathers, but as yet no bones of Birds; and to the same period must probably also be assigned the lacustrine calcareous deposits of Armissem, in Languedoc, whence M. Gervais has recovered the remains of a *Tetrao*. Near Apt, also in Provence, some traces of birds seem to have been found, but their bad condition has hindered their determination. In the marls of Ronzon, in Auvergne, several ornitholites have been found by M. Aymard, who refers them to the genera *Camascelus*, *Dolichopectus*, *Elornis* (3 spp.), and *Teracus*. Of these the first was declared to be allied to the Plovers (*Charadriidae*), the second to the Gulls, the third to the Flamingoes, and the fourth to be a Falconine; but M. A. Milne-Edwards considers the first and second to be probably identical. From the same beds M. Gervais has eggs and imprints of feathers, as well as a pelvis, referred by him to *Mergus*, but regarded by M. A. Milne-Edwards as a *Sula*; while Dr Fraas has found remains of a Harrier and a Cormorant on the top of the Swabian Alp. Finally, in North America Professor Marsh has described the remains of no less than five species of birds, varying in size from a Flamingo to a small Woodcock, but all referred by him to a genus *Alatornis*, from the Eocene deposits of Wyoming (*Am. Journ. Sc.* ser. 3, iv. p. 256).

The Miocene formation has yielded by far the greatest

number of ornitholites, especially in France, and for want of space they can be barely named here. From lacustrine deposits in Bourbonnais and Auvergne, the remains of nearly fifty species of birds have been distinguished. Besides *Palaeortyx*, already mentioned (3 spp.), *Palaeodus* (5 spp.), *Pelargopsis*, *Ibidopodia*, *Elornis*, *Hydrornis*, and *Colymboides* are extinct genera to which these fossils are referred. *Palaeodus* is perhaps the most remarkable of them—a generalized form, unquestionably allied to the Flamingoes, but presenting some characters of the *Limicola*, and at least one feature now only found in *Podiceps* and *Colymbus*. *Pelargopsis* and *Ibidopodia* were Stork-like, while *Elornis* seems to have been Scolopacine; *Hydrornis* must be placed near the Gulls, and *Colymboides* among the Divers. The rest can be referred to the existing genera—*Aquila*, *Milvus*, *Bubo*, *Pelecanus* (a very noteworthy fact, since no Parrots are now to be found in the Palearctic Region) *Picus*, *Motacilla*, *Passer*, *Columba*, *Rallus*, *Phanicopteris*, *Grus*, *Ibis*, *Totanus*, *Tringa*, *Larus*, *Phalacrocorax*, *Sula*, *Pelecanus*, and *Anas*. A very considerable number of forms identical with these have been recovered from the neighbourhood of Mentz, while many ornitholites, whether fossil bones, foot-prints, or impressions of feathers, are supplied by freshwater formations near Berne, and in Provence and Languedoc, belonging to this epoch. The bone-beds of Sanson, in Gascony, are also very productive. Here we have as extinct forms *Homolopus*, allied to the *Picidae*, *Necornis*, which seems to belong to the *Musophagidae*—a family now limited to Africa—and *Palaeoperdix* (3 spp.), a Gallinacean; while among existing genera we have represented *Aquila*, *Haliaeetus*, *Strix*, *Corvus*, *Phasianus* (2 spp.)—a genus generally supposed to have been introduced into Europe in historic times—*Rallus*, *Numenius*, *Ardea*, and *Anas*. Passing thence to Greece, the remains of birds have been found at Pikermi in Attica—a *Phasianus*, a *Gallus*—somewhat larger than *G. connerati* (the presumed ancestor of our Barndoor-fowl), and a large *Grus*. In the Tertiary deposits of the lower ranges of the Himalaya, the interesting discovery of an apparently true *Struthio* (Ostrich) has been made, with an *Argala*, and possibly a large species of *Phaeton*. From Steinheim, also, but perhaps of a somewhat later period, the remains of eight species of birds (belonging to the genera *Ibis*, *Ardea*, *Palaeodus*, *Anas*, and *Pelecanus*) have been determined by Dr Fraas, three of which seem to be specifically identical with those first discovered in France. In the Miocene of North America, Professor Marsh has detected bones of *Meloagris*, *Sula*, *Puffinus*, and *Uria*, all existing genera, but the first is especially suggestive, since it is now one of the most characteristic forms of the New World. From the Lower Tertiary of the same continent he has also described a *Bubo* and an extinct genus *Uiatornis*, probably related to the *Picidae* (*Am. Journ. Sc.* ser. 3, iv. p. 259).

The Pliocene epoch is far less rich than the preceding in ornitholites, and what have been found are less well determined. In France, the existence of a Bird-of-prey and several Water-birds has been indicated, but a species of *Gallus* from Auvergne seems to be the only form established. At G€hningen, in Baden, remains have been found, and referred to *Scolopax* and *Anas* (probably also to *Anser*), while from Radoboj, in Croatia, the almost entire foot of a bird has been assigned to *Fringilla* by Hermann von Meyer, who has further detected in Germany a fossil humerus, on which he founds a genus *Ardeacites*, allied to the Herons. From the Pliocene of North America Professor Marsh has described remains of an *Aquila*, a *Grus*, and a *Phalacrocorax*.

The Postpliocene of the same continent has rewarded

<sup>1</sup> Die Fauna von Steinheim, Stuttgart, 1871.

the same palaeontologist with two more species of *Melagriv*, another *Grus*, and an *Uria*. In Europe, beds of that epoch have not furnished very many ornitholites, while such as are known have been insufficiently studied. A *Gallus*, however, seems to have been found at Paris by M. Gervais, and other portions of the same bird have been recognized from the caves of Aquitaine by M. A. Milne-Edwards. Near Quedlinburg, remains referred to Crows, Sparrows, Swallows, a Bustard, and a Gull, have been recognized, as well as an apparent Vulturine from Magdeburg. Hermann von Meyer has indicated from the valley of the Lahn, Crows, Thrushes, Partridges, and Ducks, as well as a *Nesuda* from Salzburg. A small Owl, too, has been found at Kostritz. In England, remains of a Swan and a Cormorant have occurred in the diluvial beds of Grays in Essex, and an Owl of middle size in the Norwich Crag, which may, however, be of Pliocene age; while in France the celebrated gravels of St Acheul have supplied a bone believed by M. A. Milne-Edwards to belong to the Gray Leg-Goose (*Anser cinereus*), to which species, also, an egg found in brick earth at Fisherton, near Salisbury, has been referred by Mr Blackmoor, who in the same bed found another egg, supposed to have been that of *Anas boschas* (*Edinb. N. Phil. Journ.* N.S. xix. p. 74).

A great number of Birds' bones have been discovered in caves, and among them some bearing marks of human workmanship. In France we have first a large and extinct species of Crane (*Grus primigenia*), but more interesting than that are the very numerous relics of two species, the concomitants even now of the Reindeer, which were abundant in that country at the period when this beast flourished there, and have followed it in its northward retreat. These are the Snowy Owl (*Nyctea scandiaca*), and the Willow-Grouse (*Lagopus albus*). But here it seems unnecessary further to particularize the genera, much less the species, hitherto discovered in the caves of Europe generally, though doubtless they deserve far greater attention than they have yet received. One exception, however, must be made in the case of *Cygnus falconeri*, a gigantic Swan from the Zebug cavern in Malta (*Trans. Zool. Soc.* vi. plate 30). The caves of South America yielded to the laborious explorations of Lund no less than thirty-four species of Birds, of which the greater part are identical with those now existing in the same country; but some have become extinct, and of these the most notable are a large *Crax* and a large *Rhea*.

#### SUBFOSSIL BIRDS.

The next ancient Birds' bones known to us in the northern hemisphere are probably those of the Danish kitchen-middens. These reveal the existence (very likely, the abundance) of two species, long since banished from the spots where their remains are found—the Capercally (*Tetrao urogallus*), and the Great Ank or Gare-fowl (*Alca impennis*). Just as the *Lagopus albus* in the south of France indicates a subarctic or subalpine country with its normal fauna and flora, so does the former of these shew the coexistence with it of pine-forests in Denmark, though on other evidence it is plain that such forests cannot have existed there for many centuries. The latter, of which more must be said hereafter, does not perhaps prove more than that the surrounding seas, though cold, were free from ice in summer time.

The Birds' bones hitherto recovered from the ruins of the lake-dwellings in Switzerland are all of species which now occur more or less commonly in the same neighbourhoods, and are therefore of comparatively little interest.

On the other hand, the Fens of East Anglia have yielded proofs of a form now extinct not only in England, but even in Northern Europe. This is the Pelican, of which two

specimens, one from Norfolk and the other most likely from the Isle of Ely, are preserved in the museums of the University of Cambridge. Whether the species be identical with either of those which now inhabit some parts of Southern Europe is undetermined; but it was undoubtedly a true *Pelecanus*, and apparently only differed from *P. onocrotalus* in its somewhat larger size.

At an uncertain but (geologically speaking) recent epoch in Madagascar, there flourished huge birds of Struthious affinities. The first positive evidence of their former existence was made known in 1851 by M. Is. Geoffroy St-Hilaire, who gave the name of *epyornis maximus* to the species which had laid an enormous egg, sent to Paris a short time before; and the discovery of some bones of corresponding magnitude soon after proved to all but the prejudiced the kinship of the producer of this wonderful specimen, which not unnaturally recalls the mythical Roc that figures so largely in Arabian tales. Three, if not four, well-marked species of this genus have now been characterized from remains found in the drifted sands of the southern part of that island.

Next we must turn to our antipodes. In New Zealand birds' bones of gigantic size seem to have been first heard of from native report by Mr W. Colenso in 1838, and next year Mr R. Taylor obtained "part of a fossil toe" (*Ass. Nat. Hist.* xiv. p. 82). In the same year, however, and before news of this discovery was published, Mr Rule placed in Professor Owen's hands the fragment of a bird's femur, which the latter exhibited and described at a meeting of the Zoological Society, 12th November 1839. Other examples soon came to England, and at a meeting of the same society, 24th January 1843, that learned anatomist applied the name of *Dinornis novae-zealandiae* to the newly-found monster (*Proc. Zool. Soc.* 1843, p. 8). A few months later he was able to pronounce that he had distinguished the remains of five species of the genus (*loc. cit.* p. 144); and the memoir subsequently published in the Society's *Transactions* proved to be the first of a series unrivalled in its kind and fortunately still in progress. Bones innumerable have since been obtained, together with portions of the skin, showing the scales of the tarsus and the feathers of the body, to some of which adhered the tendons and bits of dried muscle, stones from the crop, and eggs, a few of the last containing remains of the embryo. At least eleven good species seem to have been discovered; and these, according to one of the latest authorities, Dr Haast (*Addr. Phil. Inst. Canterb.* 5th March 1874, p. 6), may be grouped in two families—*Dinornithidae* proper, having the back-toe obsolete, and comprising the restricted genus *Dinornis* (spp. 5) and *Mionornis* (spp. 2); and *Palaepterygidae*, possessing a hallux, and including the genera *Palaepteryx* (spp. 2) and *Eurypteryx* (spp. 2). It used to be taken as proved that all these birds flourished within quite recent times, and sanguine naturalists have even hoped that explorations would shew that all of them were not extinct; but, though there is abundant evidence to prove that they were the contemporaries of man in New Zealand, Dr Haast most strongly urges that the race of man who hunted and fed upon the "Moa"—for such name was applied to its bones by the natives—lived long before the Maori settlement of the islands. Here there is no room for his arguments (*Trans. N. Zeal. Inst.*), and prudence will perhaps suggest a suspension of judgment on this point. In the same formation as those which hold the relics of these wonderful birds have been found, but far more seldom, remains of others not less interesting. First there is *Harpagornis*, a Bird-of-prey, of stature sufficient to have made the largest *Dinornis* its quarry. Then we have *Cnemidornis*, a gigantic Goose—possibly related to the genus *Careopsis*, with *Aptornis* and *Notornis*—two Ralline forms,

the first allied to *Ocydromus*, and the last, which has survived to our own day, though most likely extirpated within the last fifteen years, much resembling *Porphyrio*.<sup>1</sup> In company with these fossil or sub-fossil remains are often associated bones of other forms, which now seem doomed to destruction but still exist. Finally must be mentioned *Dromornis australis*, an extinct Struthious bird, which formerly inhabited Australia, and was allied to *Dromorus*, the well-known Emeu.

#### BIRDS RECENTLY EXTIRPATED.

From the consideration of Fossil Birds we are naturally led to treat of those which have been extirpated in modern times, and are made known to us by evidence of various kinds, and more or less old. The most remarkable of these is the Dodo (*Didus ineptus*), which, on the discovery of Mauritius by the Portuguese under Mascaregnas in the beginning of the 16th century, was found to inhabit that island. Voyagers have vied with each other in describing or depicting its uncouth appearance, and its name has almost passed into a byword expressive of all that is effete. Clumsy, flightless, and defenceless, it soon succumbed, not so much to the human invaders of its realm as to the domestic beasts which accompanied them, and there gaining their liberty, unchecked by much of the wholesome discipline of nature, ran riot, to the utter destruction (as will be seen) of no inconsiderable portion of the Mauritian fauna. The latest known testimony of the Dodo's existence is furnished by the copy of a journal (now in the British Museum) kept by one Benjamin Harry, mate of the ship "Berkley Castle," which shews that it survived until July 1681. It had its life most likely sometime longer, but of this there is no evidence forthcoming. For a century and a half all that was known of it was derived from the quaint and sometimes questionable accounts of early voyagers; certain pictures, mostly by Dutch artists—for the bird was not unfrequently sent alive to Europe, and the traffic of the East Indies was then chiefly in the hands of the Netherlands—which pictures, however grotesque, were doubtless for the most part faithful portraits; and a few scattered relics—a foot in the British Museum, a head and foot at Oxford, a perfect skull at Copenhagen, and a fragmentary one at Prague. Still these (or indeed the Danish specimen alone) were enough to enable Professor Reinhardt to determine the affinity of the lost bird to the Pigeons, an alliance not before surmised, but one which scarcely anybody now disputes. In 1866, however, Mr George Clark of Mauritius discovered in the peat of a pool (the Mare aux Songes) in that island an abundance of Dodos' bones (*Ibis*, 1866, p. 141); and these, when transmitted to Europe, informed naturalists as to nearly every part of its osseous structure, which was soon after described in detail by Professor Owen (*Trans. Zool. Soc. vi. p. 49*).

But the Dodo is not the only member of its family that has vanished. The little island which has successively borne the name of Mascaregnas, England's Forest, Bourbon, and Réunion, and lies to the southward of Mauritius, had also an allied Bird, now dead and gone. Of this not a relic has been handled by any naturalist. The latest description of it, by Du Bois in 1674, is

<sup>1</sup> A second species now referred to *Notornis* is the *Gallinula alba* of Latham, which lived on Lord Howe's (and probably Norfolk) Island. No specimen is known to have been brought to Europe for more than eighty years, and only one is believed to exist—namely, in the museum at Vienna (*Ibis*, 1878, p. 44, plate 10). Recent enquiries, made at the present writer's request, have failed to furnish any result. The bird is doubtless extinct. (*Cf. Bowley, Ornithological Miscellany*, pp. 38-48.)

meagre in the extreme, and though two figures—one by Bontekoe (*circa* 1646), and another by Pierre Witthoes (*ob.* 1693) have been thought to represent it (*Trans. Zool. Soc. vi. p. 373, plate 62*), their identification is but conjectural. Yet the existence of such a bird is indubitable.

Far to the eastward of these two sister islands lies a

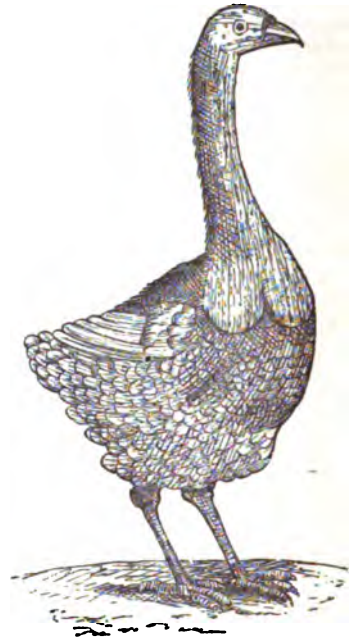

FIG. 43.—The Solitaire of Rodrigues (*Pezophaps solitaria*). From Leguat's figure.

third—Rodriguez. Here there formerly lived another Didine bird, sufficiently distinct from the Dodo of Mauri-



FIG. 44.—Extinct Crested Parrot of Mauritius (*Lophoptilanus mauritianus*). From a tracing by M. A. Milne-Edwards of the original drawing in a MS. Journal kept during Wolfhart Harmansson's voyage to Mauritius (A. N. 1603), seen by H. Schlegel (*Proc. Zool. Soc. 1874, p. 340*). Reduced.

tius to form a genus of its own—*Pezophaps solitaria*, the

Solitaire of Leguat, a Huguenot exile who, passing some time in 1691-93 on that island, has left, with a very inferior figure, a charmingly naive account of its appearance and habits, the general truth of which has been amply substantiated by Mr Edward Newton's discovery in large numbers of its bones (*Phil. Trans.* 1869, p. 327); and a nearly complete skeleton of either sex may be seen in the museum of the University of Cambridge, by the side of the most perfect specimen existing of that of its bulkier relative, the Mauritian Dodo.

Nor does this group of Didine birds contain all the lost forms of the Mascarene islands. From Mauritius have

a somewhat abnormal Starling (*Fragilupus*) existed until some forty years ago (*Proc. Zool. Soc.* 1874, p. 474), and its skin and skeleton are among the treasures of three or four museums. Perhaps, also, there were other Ralline birds, but the evidence on this head is inconclusive. In Rodrigues, the greater part of its original avifauna has vanished. There was a small but peculiar Owl (*Athene murivora*), a big Parrot (*Necropittacus rodericanus*), a Dove (*Erythrana*? sp. ign.), a large brevipennate Heron (*Ardea megacephala*), and a singular Rail (*Miserythrus leguati*)—

in some respects allied to the Mauritian *Aphanapteryx*—besides other birds of which we know from old voyagers,<sup>1</sup> though their remains have not yet been determined (as those of the species above mentioned have been) from the numerous caverns of the island. A second Parrot, or rather Parrakeet (*Palaoornis exul*), still exists, but in very small numbers, and the unique specimen known was obtained in the year 1871.

With the examples of these Mascarene Islands before us, it is not without reason that we suppose a like fate to have befallen many of the feathered inhabitants of other places exposed to similar ravages. We cannot read the accounts not merely of the earliest voyages to the Antilles, but even of those performed within the last hundred years, without being aware that the writers met with many Birds which are not now known to inhabit them. These lost species, there is some ground for believing, were mainly, if not wholly, peculiar to the locality, and after having made good their existence, maybe, for ages, fell easy and helpless victims to the forces which European civilization brought into play. Chief among these forces was fire. In all countries and at all times it has been the habit of colonists to burn the woods surrounding their settlements,—partly to clear the ground for future crops, and partly (in tropical climates especially) to promote the salubrity of their stations. When fire was set to the forest and bush of a small island, the whole of which could be burnt at once, the

disastrous effect on its fauna can easily be conceived. Even the animals which happened to escape the conflagration itself would speedily starve, owing to the at least temporary destruction of the native flora whence, either directly or indirectly, they derived their wonted sustenance. Thus in certain of the Virgin Islands the "dead" shells of many species of terrestrial Gasteropods are everywhere found in astounding numbers, while not a living individual of several of the species has ever been met with by the conchologists



A. Mandible of *Aphanapteryx*, side view. From the original in the Museum of Zoology of the University of Cambridge.



B. Left Tibia of *Aphanapteryx*, hind and inside views. From the original at Cambridge.

C. Right Tarsometatarsus of *Aphanapteryx*, front and inside views. From the original at Cambridge.

FIG. 44.—These figures reproduced from *The Ibis*, 1869, by permission of the Editor. Natural size.

disappeared at least two species of Parrot, a Dove, a large Coot, and a second Ralline bird, abnormal, flightless, and long-billed—*Aphanapteryx*. A painting of this last was found by Von Frausfeld in the emperor's library at Vienna, and some of its bones, rescued by Mr Edward Newton from the peat of the Mare aux Songes, have been fully described by M. A. Milne-Edwards. Remains of the Coot and one of the extinct Parrots were found also in the same spot, while skins of the other Parrot and of the Dove still exist in a few museums. Réunion, also, once had other birds now lost, and so had Rodrigues. In the former,

<sup>1</sup> *Proc. Zool. Soc.* 1875, pp. 39-42.

of our day. The only assignable cause of the extinction of these creatures lies in the fact that these islands are known to have been laid waste by fire. The shells have resisted destruction but how many more animals must have

the period just mentioned was long subsequent to that in which the primeval woods of the islands were burnt. What, then, must not have been the changes which the forest-fires produced?



FIG. 46.—Distal portion of mandible of *Lepidopteryx*, lower and upper view. From specimens in the British Museum. These figures reproduced from *The Ibis*, 1866, by permission of the editor. Natural size.

perished without leaving a trace of their existence? Even at the present time, few parts of the world so overrun by people of European descent are from a naturalist's point of view so little known as the West-India Islands. Still



FIG. 47.—Extinct Starling of Réunion (*Pragipitrus corvus*), adapted from figures by Deatenton, Levaillant, and others. Reduced.

less is known of their state a century ago; and it would be a long and wearisome task to collect from old voyages the meagre, scattered, and often inaccurate information they contain as to the zoology of these islands. One example may, perhaps, be sufficient. Ledru accompanied an expedition sent out in 1796 by the French Government to the West Indies. In his work he gives a list of the birds he found in the islands of St Thomas and St Croix (*Voyage aux Isles de Tenerife, &c.*, Paris, 1810, ii. p. 29). He enumerates fourteen kinds of birds as having occurred to him then. Of these there is now no trace of eight of the number; and, if he is to be believed, it must be supposed that within fifty or sixty years of his having been assured of their existence, they have become extinct.<sup>1</sup> And yet

If this be not enough we may cite the case of the French islands of Guadeloupe and Martinique, in which, according to M. Guyon (*Comptes Rendus*, lxxiii. p. 589), there were once found six species of *Psittaci*, all now exterminated; and it may possibly be that the Macaws stated by Mr Gosse (*B. Jamaica*, p. 260) and Mr Marsh (*Proc. Acad. N.S. Philad.*, 1863, p. 283) to have formerly frequented certain parts of Jamaica, but not apparently noticed there for some twenty-five or thirty years, have fallen victims to colonization and its consequences.

Mention has already been made of the Gare-fowl (*Alca impennis*), whose bones have been found in the kitchen-middens of Denmark, and more lately in similar deposits in Caithness. This species, nearly allied to our common Razor-bill (*A. torda*), but flightless and about twice as big, seems to have become extinct since 1844, in which year

the last two examples known to have lived were taken on a rocky islet—one of a group called Fuglakér, or Fowl-akerries, off the south-west point of Iceland. Ten years before, one had been caught alive at the entrance of Waterford harbour; and in 1821 or 1822 one was taken near St Kilda, to which lonely island, as appears from old authors, the bird had been accustomed to resort in the breeding season. In 1813 a pair were killed at Papa-Weatray, which was also a breeding station of the species, and the stuffed skin of one of them is preserved in the British Museum, while that of the Waterford specimen may be seen in the museum of Trinity College, Dublin. In the Færoes the species was formerly common, but it certainly ceased from appearing there about the beginning of the present century. In the Iceland seas there are three localities called after the bird's name, but on only one of them has it been observed for many years, having probably been as long extirpated in the rest as in the Færoes. On the locality where it continued latest, there is ample evidence to show that it once was plentiful. There was a large akerry—the Geirfuglakér proper—on which, in 1813, the crew of a Færoese vessel made a descent and slaughtered a large number of Gare-fowls; but this, like the rest of the group, was a place very difficult of access, and, in 1821, Faber, the well-known faunist of Iceland, failed to land upon it, though some of his companions reached the Geirfugladráng, a smaller islet lying further to seaward. In 1830 the large akerry, through a submarine volcanic eruption, disappeared beneath the waves, and immediately after a colony of Gare-fowls was discovered on another rock lying nearer the mainland, and known as Eldey.<sup>2</sup> In the course of the next fourteen years, not fewer probably than sixty birds were killed on this newly-chosen station, and a nearly corresponding number of eggs were brought off; but the colony gradually dwindled until, as above said, in 1844 the last two were taken (*Ibis*, 1861, p. 374).

In Greenland, for the last three hundred years, the Gare-fowl has only been known as an occasional straggler, but it would appear that in 1574 a party of Icelanders found it so plentiful at a spot on the east coast—since identified

few years ago restricted to a single hill-top in St Thomas, and as reduced in numbers that the present writer was ridiculed by many of the inhabitants for believing that such a bird ever existed in the island. Found, however, it was at last, but it must be regarded as verging upon extinction.

<sup>2</sup> Whether on the subsidence of the large akerry another portion of the birds which frequented it colonized the outermost islet is not known, for this spot does not seem to have been visited by any human being since Faber's time, more than fifty years ago.

<sup>1</sup> One of the survivors (a Parrakeet, *Ceruus sanctolæus*) was a

with Danell's or Graah's Islands—that they loaded one of their boats with their captives. All recent explorations of this inhospitable coast prove the utter vanity of the notion that the Gare-fowl is able there to find an asylum.

But it was in the sea of Newfoundland that this species, known to the settlers and fishermen as the "Penguin,"—a corruption of the words "pin-wing,"—was most abundant, as a reference to Hakluyt's and similar collections of voyages will prove. In 1536, or forty years after the discovery of the country, we find an island taking its name from the bird, and others are even now so called. English and French mariners alike resorted to these spots, driving the helpless and hapless birds on sails or planks into a boat, "as many as shall lade her," and salting them for provision. The French crews, indeed, trusted so much to this supply of victual, as to take, it is said, but "small store of flesh with them." This practice, we learn from Cartwright (*Journal, &c.*, iii. p. 55), was carried on even in 1785, and he then foresaw the speedy extirpation of the birds, which at that time had only one island left to breed upon. In 1819, Anspach reported their entire disappearance, but it is possible that some few yet lingered. On Funk Island, their last resort, rude enclosures of stones are, or recently were, still to be seen, in which the "Pin-wings" were impounded before slaughter; and a large quantity of their bones, and even natural mummies, preserved partly by the antiseptic property of the peat and partly by the icy subsoil, have been discovered. One of the last has furnished the chief materials from which the osteology of the species has been described (*Trans. Zool. Soc.* v. p. 317). Some 70 specimens of the bird's skin, about as many eggs, and nearly half-a-dozen more or less perfect skeletons, with detached bones of perhaps an hundred individuals, are preserved in collections; but even if there be any truth in the various reports of the appearance of the species since 1844 (some of which seem to rest on fairly good testimony), so that it may still survive, it is obvious that its rediscovery will most likely seal its fate.

Far less commonly known, but apparently quite as certain, is the doom of a large Duck which even fifty years

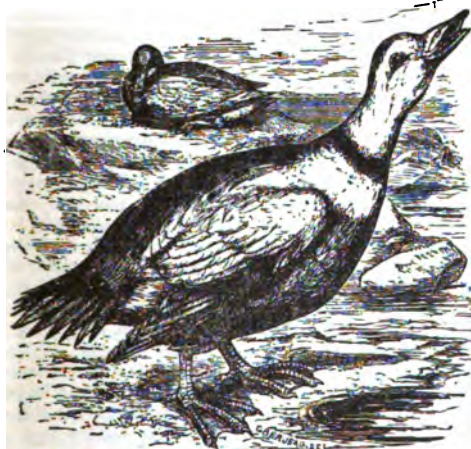

FIG. 61.—Red Duck (*Somateria labradorae*), male and female. From specimens in the British Museum. Redneck

ago was commonly found in summer about the mouth of the St Lawrence and the coast of Labrador, migrating in winter to the shores of Nova Scotia, New Brunswick, New England, and perhaps further southward. For many years

past, according to the best-informed American ornithologists, not a single example has been met with in any of the markets of the United States, where formerly it was not at all uncommon at the proper season, and the last known to the writer to have lived was killed by Col. Wedderburn in Halifax harbour in the autumn of 1852.<sup>1</sup> This bird, the *Anas labradorae* of the older ornithologists, was nearly allied to the Eiders (*Somateria*), and like them used to breed on rocky islets, where it was safe from the depredations of foxes and other carnivorous quadrupeds. This safety was however unavailing when man began yearly to visit its breeding-haunts, and, not content with plundering its nests, mercilessly to shoot the birds. Most of such islets are, of course, easily ransacked and depopulated. Having no asylum to turn to, for the shores of the mainland were infested by the four-footed enemies just mentioned, and (unlike some of its congeners) it had not a high northern range, its fate is easily understood. No estimate has yet been made of the number of specimens existing in museums, but it is believed to be not very great.

Another bird which has become extinct within the last few years is one of a group of Parrots (*Nestor*) peculiar to



FIG. 60.—Phallip Island Parrot (*Nestor productus*). From specimen in the British Museum. Redneck

the New-Zealand Subregion, and though some of its congeners still exist in the less-frequented and alpine parts of that country, this species (*N. productus*) seems to have been confined to Phallip Island. The last known to have lived, according to information supplied to the writer by Mr Gould, was seen by that gentleman in a cage in London about the year 1851. Not much more than a dozen specimens are believed to exist in collections.

BIRDS PARTIALLY EXTERMINATED.

From Birds which have recently become altogether extinct we naturally turn to those that have of late been extirpated in certain countries though still surviving elsewhere. Several such instances are furnished by the British Islands. First there is the Crane (*Grus commensis*) which in Turner's time (1555) was described as breeding in our fens. Then the Spoonbill (*Platalea leucorodia*), said by Sir Thomas Browne

<sup>1</sup> It is needless to observe that no one at that time had any notion of its approaching extinction.

(1688) to breed in Suffolk, as it formerly had done in Norfolk. The Capercally (*Tetrao urogallus*) we know to have frequented the indigenous pine-forests of Ireland and Scotland. In the former it had most likely become extinct soon after 1760, and in the latter not much later. Not a single specimen of the British stock of this bird is known to exist in any museum, but the species has been successfully introduced from Sweden into Scotland during the last forty years, and is now certainly increasing in numbers. The Bustard (*Otis tarda*), which once tenanted the downs and open country of England from Dorset to the East Riding of Yorkshire, vanished from Norfolk, its last stronghold as a British Bird, in 1838. From other counties it had before disappeared. It is well worthy of note that all the four species just mentioned were protected to a certain degree by Acts of Parliament, but these laws only gave immunity to their eggs and none to the parent-birds during the breeding season, thus shewing how futile is the former when compared with the latter, since there are very many species whose nests from time out of mind have been and are yearly pillaged without any disastrous consequences arising from the practice.<sup>1</sup>

It would be impossible here to name the many Birds which, once numerous in the British Islands, have now so much diminished as to be rightly considered scarce, or to recount the various causes to which their diminution is due. The persecution of Birds-of-prey seems to have begun with the keepers of poultry, to whom the Kite (*Milvus icinus*) and the Hen-Harrier (*Circus cyaneus*) were a sore trouble,<sup>2</sup> but it has been actively followed up by game-preservers, and this to their own cost, as the ravages of the Grouse-disease testify.<sup>3</sup> To the reclaiming of waste lands, the enclosure of open spaces, and the greater care bestowed on timber trees (by removing those that being decayed are much infested with insects) must, however, be attributed the extermination or rarification of far more species than the direct action of man has been able to effect.<sup>4</sup> Still what we lose in one direction we gain in another, and while Birds-of-prey and Wild-fowl are being banished, the smaller denizens of the woodlands, gardens, and arable fields are unquestionably more numerous than ever.<sup>5</sup> The change is, of course, not satisfactory to the naturalist or to the lover of wild scenery, but to some extent it seems inevitable; yet well directed laws for the protection of those birds which suffer worst in the unequal contest may delay their impending fate, and preserve to our posterity the most pleasing features of many a landscape and the grateful opportunities of studying many a curious and interesting species. Thanks, perhaps, to the stronger constitution of most Palearctic Birds, the votaries of what is called "acclimatization" have obtained little success in these islands, for the

exotic species which it has been attempting to introduce have, almost without exception, failed to establish themselves. The efforts made in some British colonies—particularly in Australasia—are unfortunately too likely not to be successful; and, when their own peculiar fauna has been half extirpated, our fellow-subjects at the antipodes will probably have good reason to lament the extraordinary sentiment that has led them to introduce from other countries birds which, in the absence of their natural checks, will be nothing else than a positive nuisance; for so reckless is the manner in which they have been imported, that species possessing few or exceedingly doubtful recommendations to begin with have been carried over in abundance, and some of these cannot fail to become permanent settlers equally with those for the transportation of which the would-be "acclimatizers" might find themselves excused. All, however, in the battle of life will contribute first to the subdual and by degrees to the disappearance of the original inhabitants, which had hitherto constituted a fauna, from a scientific point of view, perhaps the most interesting on the face of the globe.

#### GEOGRAPHICAL DISTRIBUTION OF BIRDS.

It is admitted by nearly all naturalists that the study of the extinct organisms of any country leads the investigator of them to a proper appreciation of its existing flora or fauna; while, on the other hand, a due consideration of the plants or animals which may predominate within its bounds cannot fail to throw more or less light on the changes it has in the course of ages undergone. That is to say that the Distribution of forms in Time is a subject so much connected with the Distribution of forms in Space, that the one can hardly be separated from the other. Granting this as a general truth, it must yet be acknowledged as a special fact, which some of the preceding paragraphs will perhaps have foreshadowed, that in fossil Ornithology we have as yet but scanty means of arriving at any precise results which will justify bold generalization in the matter of avian distribution. Remains of extinct forms of Birds are, compared with those of other classes of Vertebrates, exceedingly scarce, and in accordance, therefore, with the prevalent practice of naturalists they have been but little investigated. If we except France and New Zealand—and in the latter no fossil ornithic relics can be assigned to any very ancient epochs—little has been done. The discovery in the former of some somewhat early remains of Birds, allied to those which we at present only know as denizens of a tropical region, and the recognition of far later remains of species identical with those that now flourish in arctic lands, merely corroborates what is from numerous sources within the knowledge of every geologist—the vicissitudes, namely, of which that part of Europe has had experience. Though in this quarter of the globe we now have no indigenous Struthious Birds, the former existence of Struthious Birds even in England proves very little, because we know that some of such birds (the species of South-American *Rhea*, for instance) can maintain themselves in lands which are subject to a climate as fitful, if not as severe, as our own. All that can be justly inferred thence is that Struthious Birds were not formerly confined to their present limits, and possibly that such birds once pervaded the greater part of the earth's surface. The *Archaeopteryx* and *Odontopteryx* from their singularity prove nothing in respect of Geographical Distribution. Perhaps in the whole range of zoology there is no class from the fossil remains of which we learn less as regards the physical history of our planet than we do from the Birds. We, therefore, have to turn to the other side of the question of Distribution, and try to find out whether the

<sup>1</sup> The singular wisdom of the old command (Deut. xxii. 6)—the most ancient "game-law" (using the term in its widest sense) in existence—has here a curious exemplification.

<sup>2</sup> The Bohemian Scheschek, who visited England about 1461, says he had nowhere seen so many Kites as around London Bridge (*Hist. Lit. Ver. Stuttgart*, vii. p. 40). And the statement is confirmed by Belon (*Obs. ed. An. Gens. Acad.* p. 108), who says that they were scarcely more numerous in Cairo than in London, feeding on the garbage of the streets and even of the Thames. From the same writer (*Hist. Nat. Ovescor*, p. 181) it would seem that at that time (1555) they, and Ravens also, were protected by law in the City! The Hen-Harrier's name is enough to shew what was thought of it in days when it abounded.

<sup>3</sup> In Transbaikalia, the Bearded Vulture (*Gypsetus barbatus*), which was formerly common, has of late been completely exterminated, through persecution prompted by the desire to obtain its feathers, which are highly valued.—Von Middendorff, *Sibir. Reise*, iv. p. 861.

<sup>4</sup> The extermination from Europe of the Francolin (*Francolinus vulgaris*) has been treated at some length by Lord Lilford (*Ibid.*, 1862, p. 362) without his being able to assign any cause for the fact.

<sup>5</sup> Report from the Select Committee on Wild Birds' Protection, &c. (House of Commons), 1873. Appendix, pp. 188-193.



evidence, which is from one point of view so evidently deficient, may not be supplied by inquiry into existing *ovifera*, and this, in other words, signifies that a knowledge of the Geographical Distribution of living Birds becomes a matter of prime necessity to every one who would intelligently exercise the calling of an ornithologist.

Thus driven to a kind of extremity, the student of Birds, however, cannot but regard with the most lively satisfaction the circumstance that to one of his brethren is due the merit of having first truly pointed out the great Zoogeographical Regions of the globe—a fact not a little surprising when we reflect that the outlines of Distribution laid down in 1857 by Mr Sclater<sup>1</sup> had reference only to the most vagrant Class of animals in creation; yet these outlines have, not merely in the main, but to a very great extent in detail, met with the approval of nearly all those zoologists who have since studied the subject in its bearing upon the particular Classes in the knowledge of which they themselves stand pre-eminent.

Without infringing upon what must be deemed the generalities of biological Distribution, it is proper to observe that Mr Sclater's success is to be attributed to the method in which his investigations were carried on—a method in which he had but few predecessors. Instead of looking at the earth's surface from the point of view which the geographer would take of it (a point of view which had hitherto been adopted by most writers), mapping out the world according to degrees of latitude and longitude, determining its respective portions of land and water entirely regardless of the products of either element, or adhering to its political divisions—time-honoured as they were,—he endeavoured to solve the question simply as a zoologist should, by taking up the branch of the subject with which he was best acquainted, and by pointing out and defining the several Regions of the globe in conformity with the various aspects of ornithic life which they present. But herein there was at once a grave difficulty to be encountered. Birds being of all animals most particularly adapted for extended and rapid locomotion, it became necessary for him to eliminate from his consideration those groups, be they large or small, which are of more or less universal occurrence,<sup>2</sup> and to ground his results on what was at that time commonly known as the order *Insectores* or *Passeres*, comprehending the orders now generally differentiated as *Passeres (veræ)*, *Picariæ*, and *Psittaci*.

On this basis then Mr Sclater was enabled to set forth that the surface of the globe exhibited *six* great Regions, each in a marked manner differing from all the rest, though the difference was not always equally important. These Regions he termed respectively the Palaearctic, Ethiopian, Indian, Australian, Nearctic, and Neotropical; and though it is on all accounts better to preserve the names he bestowed on them, it does not seem convenient to follow the order in which he placed them. Thus the Australian Region appears not only to differ more from the others than they do among themselves, but its differences are of a kind which, when its fauna is considered as a whole, suggest a striking peculiarity, namely, that many of the forms of animal life therein found are the direct and not very much modified descendants of types which may very likely at an early period of our planet's history have predominated over every land, but of types which have since

been elsewhere in great part replaced by more highly developed structures. The lower rank in the scale of its most characteristic animals seems to be indisputable, and, therefore, with the Australian Region it appears most proper to begin.<sup>3</sup>

I. THE AUSTRALIAN REGION is most trenchantly divided from the Indian, which, from a geographical and possibly from a geological point of view, seems to be conterminous with it, by the narrow but deep channel which separates the small islands of Bali and Lombok, and will be found to determine the boundary between two entirely distinct portions of the earth's surface. Midway along this channel we may draw a line in our imagination, and continue it in a north-north-easterly direction up the Strait of Macassar, dividing the much larger islands of Celebes and Borneo. A considerable interchange of animal forms in the two islands last named is indeed to be observed, and even a slight intermingling of the productions of the two former seems now to be going on; but the inoculation is so much less in degree than that which obtains between any other two Regions, while the characteristic, not to say peculiar, zoological types which occupy either side of this line are so divergent, that it may be fairly considered a harder and faster line than any that can elsewhere be found. Between Bali and Lombok, as above stated, it has been shown by Mr Wallace to be all but perfect, and in his honour this boundary, as real in the abstract as though it existed in the concrete, has been most justly named after the naturalist and traveller who first saw and recognized its importance—"Wallace's Line."<sup>4</sup> As above indicated, this line becomes less definitive as it proceeds further northward; and though we know it to pass between the Philippine Islands and Sanguir, and again between the former and the Palau group, its further progress in that direction cannot as yet be set down with precision, though it probably runs to the westward of the Ladrones. But heretofore we lose sight of it, until we arrive at the Sandwich Islands, to the northward of which it must pass, since for reasons presently to be given at greater length that archipelago must be confined within the Australian Region. Southward from Lombok the boundary of the Region rounds the western coast of Australia, and then strikes off in a south-easterly direction to encompass New Zealand and its dependencies. Arrived here it must be drawn so as to include all of what is commonly known as Polynesia, though the characters of the intermittent chain of islets lying parallel to and just to the southward of the Tropic of Capricorn, and a few scattered reefs to the northward of the equator (between long. 108° and 115° W.), are at present insufficiently determined. After encircling, however, the Low Archipelago and the Marquesas, the boundary trends to the north-west, and includes, as before stated, the Sandwich Islands; but thence its precise direction cannot now be traced, owing to the obscurity which veils the numerous islets of the North Pacific Ocean, which

<sup>1</sup> The writer has to acknowledge with hearty thanks the very singular mark of confidence conferred on him by his eminent friend Mr A. R. Wallace, who has allowed him to peruse in manuscript the greater part of a work on the Geographical Distribution of Animals, the early publication of which can hardly fail to place this most interesting subject in the position it undeniably deserves, but a position to which it has never yet attained through the absence of any treatise of like character. The value of the favour thus bestowed upon him the writer cannot overestimate.

<sup>2</sup> This name was first given by Professor Huxley (*Proc. Zool. Soc.* 1868, p. 818), but as it is hardly a geographical term, it will accordingly make no appearance on any map—a so-called "physical" map. The value of the discovery above mentioned, of which no one had ever dreamt till it was made by Mr Wallace, seems to justify proper notice from cartographers, and it might be well, therefore, to dignify the channel between Bali and Lombok—named on some maps Lombok Strait—by the appellation of "Wallace's Strait."

<sup>3</sup> *Journal of the Proceedings of the Linnean Society, Zoology*, ii. pp. 180-146. It is much to be regretted that the author of this most valuable essay has never sanctioned its republication in another and improved form. Many of its details, and some of its principles even, are now known to be incorrect, but for the time at which it appeared it was a marvellous production.

<sup>4</sup> Not but that even in the most widely-spread groups are contained other—sub-families, genera, or species strictly limited to certain localities. Some of these will be noticed further on.

lie between that group and the coast of Asia. All that can be said for certain is, that it does not comprise the Aleutian Islands, the empire of Japan, or the Loochoos.

Though the characteristic Mammals of the Australian Region are in every way highly remarkable, entirely comprehending as they do one of the three Subclasses (*Ornithodelphia*) and nearly all of a second (*Didelphia*), by far the largest portion of the area it covers is weak if not absolutely wanting in Mammalian life, and the zoological features which mark the Region as a whole are perhaps better exhibited by its Birds than by any other Class of its fauna. This being the case, it may be excusable in this place to dwell longer upon this Region than upon the rest. True it is that we have no Subclass of birds, like the *Ornithodelphia* among Mammals, which is restricted to the Region; but, on the other hand, the instance of the *Didelphia*, to which allusion has just now been made, is here almost exactly paralleled by that of the Struthious Birds—the *Ratitæ*, to call them by the name now very generally applied to them by the zoologists who recognize them as forming one of the two primary divisions or Subclasses, we may term them, of the Class *Aves*. All the existing *Ratitæ* (with the exception of the species of two forms, the Ostriches of Africa and South America, belonging to the genera *Struthio* and *Rhea*, and comprising at most but five species) are found within the Australian Region and nowhere else. But further, the *Ratitæ* of the Region are more widely distributed throughout its area than are the *Didelphia*, since the former extend from Ceram, in lat. 4° S. and long. 130° E., to New Zealand in lat. 45° S. and long. 175° E., if not a little further, while the *Didelphia* stop short at lat. 44° S. and long. 155° E.<sup>2</sup> But if we take the birds alone, and compare the two Subclasses into which the existing or recent members of the Class are divided, we find the Australian Region remarkable for its ornithic singularity. The smaller of these two Subclasses, the *Ratitæ*, contains six very natural groups—which might well be called Orders—including, according to the most exaggerated computation of their number, less than 40 species, while the larger Subclass, the *Carinatæ*, though perhaps not including more truly natural groups, comprehends some 10,000 species. Now, out of the six groups of this smaller Subclass, four are absolutely restricted to the Australian Region, and these four groups contain all but, at the highest estimate, as above stated, five of the species known to belong to the Subclass; thus we should be able to regard the 35 species of recent *Ratitæ* of the Region (a number which is clearly far too large) as the proportional equivalent of an avifauna of more than 8000 species (8750).

Leaving, however, such a calculation as this, which indeed cannot as yet be more than an approximation to the truth, we must consider first the remaining ornithic features of the Region as a whole, and then those of its parts. With respect to each of those subjects, it will be evident to every one that a further division is at once incumbent upon us. The prevalent zoological features of any Region are of two kinds—negative and positive. It is therefore just as much the business of the zoogeographer, who wishes to arrive at the truth, to ascertain what groups of animals are wanting in any particular locality (altogether independently of its extent) as to determine those which are forthcoming there.

<sup>1</sup> Of course, as regards polymorphism, no comparison can be made between the *Ratitæ* and the *Didelphia*, the latter presenting a very great variety and the former a very great sameness of structure and habit, though if it be true, as seems to be most likely the case, that *Dinornis* and its allies were absolutely devoid of wings, we should in them have a divergence from the normal ornithic type which is altogether unique in the whole Class, and for its singularity might well be set off against the multifariousness exhibited by the *Didelphia*.

Of course, in the former case it would be absurd to regard as a physical feature of any great value the absence from a district of groups which do not occur except in its immediate neighbourhood; but when we find that certain groups, though abounding in some part of the vicinity, either suddenly cease from appearing or appear only in very reduced numbers, and occasionally in abnormal forms, the fact obviously has an important bearing. Now, as has been above stated, mere geographical considerations, taken from the situation and configuration of the islands of the so-called Indian or Malay Archipelago, would indicate that they extended in an unbroken series from the shores of the Strait of Malacca to the southern coast of New Guinea, which confronts that of North Australia in Torres Strait, or even further to the eastward. Indeed, the very name Australasia, often applied to this part of the world, would induce the belief that all the countless islands, be they large or small—and some of them are among the largest on the globe—were but a southern prolongation of the mainland of Asia. But it has been already stated that so far from this being the case a very definite barrier is interposed. A strait, some 15 miles or so in width, and separating the two fertile but otherwise insignificant islands of Bali and Lombok, makes such a frontier as can hardly be shewn to exist elsewhere. The former of these two islands belongs to the Indian Region, the latter to the Australian, and between them there is absolutely no true transition—that is, no species are common to both which cannot be easily accounted for by the various accidents and migrations that in the course of time may have tended to mingle the productions of islands so close to one another. The faunas of the two are as absolutely distinct as those of South America and Africa, and it is only because they are separated by a narrow strait instead of the broad Atlantic that they have become so slightly connected by the interchange of a few species and genera.

Now, first, of the forms of Birds which are prevalent throughout the Indian Region, but are entirely wanting in the Australian, we have at once the Bulbuls (*Ictida*), very characteristic of most parts of Africa and Asia, with the allied group of *Phyllornithida*, which is peculiar to the Indian Region; the widely-spread families of Barbets (*Megalaniida*) and Vultures (*Vulturida*); and the Pheasants (*Phasianida*), which attain so great a development in various parts of the Asiatic continent and islands that there must their home be regarded as fixed, though some species are found very far removed from the focus of the family.<sup>3</sup> Some naturalists would add the Finches (*Fringillida*), but the real position of the so-called "Finches" of Australia must at present be considered extremely doubtful, and it may prove that they are the direct descendants of the more generalized group whence sprang both the true *Fringillida* and the *Ploceida*, if, indeed, these can justifiably be kept apart. Then, of forms which are but weakly represented, we have the otherwise abundant Thrushes (*Turdida*), and, above all, the Woodpeckers (*Picida*), of which some 4 species, or at most 5,<sup>4</sup> out of more than 300, just cross

<sup>2</sup> The separation of this family from the *Tetraonida* (Partridge and Grouse), though hitherto almost universally recognized, seems to be a very questionable proceeding, and, so far as the present writer is aware, is one that can only be maintained by structural characters, which though patent in their extreme forms, appear to vanish in those which are intermediate (cf. Proc. Zool. Soc. 1868, pp. 300, 301); but for the purposes of this treatise it is of little consequence, since the *Tetraonida* are but very feebly represented in the Australian Region.

<sup>3</sup> It is almost certain that no satisfactory limits can be laid down between this family and the Warblers (*Sylviida*), but, as in the one mentioned in the last note, the result would hardly be affected by combining the two families, since the *Sylviida* have comparatively few members in the Region now under notice.

<sup>4</sup> There are said to be *Dendrocygna anas* in Lombok, *Mucrocygna albus* and *Fuliginea lemniscata* in Celebes, *F. macrourus* in the

the boundary and occur in Lombok, Celebes, or the Moluccas, but are absolutely unknown elsewhere in the Region.

Turning to the families which by their presence characterize the Australian Region, we find those which are peculiar to it to be perhaps, if not more numerous, yet more remarkable than the peculiar families of any other Region. Nearly 20 such might here be enumerated. One, the Honeysuckers (*Meliphagida*<sup>1</sup>), is most characteristic, and, abounding in genera and species, extends to almost every part of the region, yet only a single species oversteps its limits, crossing the sea from Lombok to Bali.<sup>2</sup> Other peculiar families are much more confined, and, since by their means (as will presently appear) the various subdivisions of the Region may be more clearly marked out, further notice of them may be for the present deferred. But the positive characteristics of the Region as a whole are not its peculiar forms alone; there are at least 4 families which, being feebly represented elsewhere, here attain the maximum of development. Such are the Thickheaded Shrikes (*Pachycephalida*), the Caterpillareaters (*Caspephagida*), the Flowerpeckers (*Dicaeida*), and the Swallow-Flycatchers (*Artamida*). Besides these, 3 or perhaps 4 groups, though widely distributed throughout the world, arrive in the Australian Region at their culmination, presenting an abundance of most varied forms. These are the Weaver-birds (*Ploceida*), and the Moreporks (*Podargida*), if they can be properly separated from the *Fringillida* and the *Caprimulgida* respectively, but especially the Kingfishers (*Alcedinida*) and the Pigeons (*Columbida*), the species belonging to the two last obtaining in this Region a degree of prominence and beauty which is elsewhere unequalled.

Without going into greater detail, the Australian Region may be roughly said to be composed of four Subregions, to which the names of Papua (or New Guinea), Australia proper, New Zealand, and Polynesia may perhaps be attached. The boundaries of some of these Subregions are, as may be expected, not well defined; and, indeed, it is obvious that much must be done in the way of geographical exploration before the investigation of zoologists will mark out their limits with positive accuracy. Especially is this true in respect of the first of these Subregions, which in certain parts shows a complication of characters that for want of space could hardly here be explained, if, indeed, according to our present information, they can be explained at all.

(1.) *The Papuan Subregion*, the chief province of which is formed by New Guinea and its dependencies, comprises, besides the large and imperfectly-known island whence its name is derived, three other provinces, which may be named the Timorese, the Celebesian, and the Moluccan. The fauna of the Timor group seems to be made up of contributions from Java, belonging to the Indian region, the Moluccas, and Australia. Of nearly 100 genera and 160 species of Land-birds only, which are here found, an equal proportion appears to be related to the Birds of the Indian Region and to those of Australia proper—some 30 genera being distinctly traceable to each. The Indian influence is made evident by the presence of about 27 genera which have crossed the strait from Bali into Lombok. Of these, 12 are known to stop short at Flores, but the inter-

vening island of Sumbawa has not yet been ornithologically explored, and 13 of them reach Timor. In all there may be, disregarding birds of wide distribution, some 30 species of Indian origin, with nearly 20 thereto allied, but, on the other hand, more than 60 which are derived from Australia, thus indicating a greater affinity to the latter country. There is one genus of Kingfishers (*Caridonas*) known only from Lombok and Flores, but no doubt represented in Sumbawa, and a genus of Pigeons (*Leucotreron*) is almost limited to this group.

The Celebesian province is known to be inhabited by more than 200 species, belonging to about 150 genera. Of the Land-birds, 9 genera and nearly 70 species are absolutely confined to the principal island, but 20 more are found also in the Sula and Sangur islands, making nearly 90 species peculiar to this Subregion. Of those which are not peculiar, Lord Walden<sup>3</sup> estimates that about 55 are of Indian and 22 of Australian origin, the remainder being common to both Regions, and thus the Indian influence is very strong in this quarter, pointing to an immigration from the north and west. Of the less wide genera of Celebes, more than 20 are common to Borneo and Java, and nearly as many to Timor or the Moluccas—again showing a preponderance of Indian over Australian types; but, since the Bornean and Javan species consist of only about one-quarter of those which are characteristic of those islands, while the Moluccan and Timorese genera form nearly one-half, the proportion which has been drawn from the rest of the Australian Region is clearly greater than that which has flowed in from the Indian. The most important family of *Meliphagida*, however, which, as before remarked, is so highly characteristic of the Australian Region, is here represented by a single species only (*Myciocola chloroptera*), and the fact requires due acknowledgment. On the other hand, some 8 Indian families which are very important in Borneo and Java are altogether absent, and the non-appearance of a still greater number of Moluccan forms is also worthy of note. The conclusion at which Mr Wallace arrives from these and some other circumstances is that Celebes, during the existing epoch, has never been united by extensive land with either side, but has received an influx of immigrants from each. Of the genera found in Celebes itself 9 are peculiar, 3 more occur in one other island only, and 1 (which is likely to be eventually discovered in Celebes) is as yet known but in the Sula group. Of these 13 genera peculiar to the Subregion, about one-third are modifications of Australian forms. The Sula Islands show a considerable blending of faunas; out of nearly 40 species of Land-birds, more than one-half are identical with or allied to those of Celebes; but 3 Moluccan genera, unknown to Celebes, occur here.

We have now to consider the Papuan province. The island of New Guinea, which is the centre of the whole Papuan Subregion, has been until lately almost entirely unexplored, and even at the present day its interior has been but scarcely and cursorily visited by civilized foreigners. Yet out of nearly 350 species of Land-birds, belonging to 125 genera, which are known to us from this country, 300 species are exclusively peculiar to it, and 36 genera are either peculiar or only just extending to North Australia. Of the remaining genera, 38 are peculiar to the province, 45 are characteristically Australian, 9 more especially belong to the Malay Archipelago generally, being as much Australian as Indian. Only 7 are typically Indian, but with a discontinuous distribution, while 25 have a wide range. The chief features of the province to be noted are the extraordinary development therein of the Cassowaries

Moluccas, and *F. olivaceus* there or perhaps in the Banda Islands. It is quite likely, however, that further investigation will add to the number.

<sup>1</sup> This term is here advisedly used in a restricted sense, excluding the genus *Zosterops* and its allies, which are often included under it by systematists.

<sup>2</sup> This is *Phalotis melanotis*, a species which is common from Timor to Lombok.

<sup>3</sup> *Transactions of the Zoological Society*, vol. ii. pp. 23-118.

(*Casuaridae*),<sup>1</sup> the richness and specialization of the Kingfishers (*Alcedinidae*), Parrots (*Psittacae*), and Pigeons (*Columbidae*), its Birds-of-Paradise (*Paradisidae*), Honey-suckers (*Meliphagidae*), and some remarkable Flycatchers (*Muscicapidae*). It has several marked deficiencies compared with Australia, among which are the Warblers (*Sylviidae*), Babbler (*Timeliidae*), Finches or Weaver-birds (*Fringillidae* or *Placidae*)—according as we are disposed to treat those groups—certain Parrots (*Platyserinae*), and Diurnal Birds-of-Prey (*Falconidae*), and, above all, the Emsus (*Dromidae*). About 9 genera are especially Malayan, and nearly as many more have apparently the same origin, but, curiously enough, are not found in the intervening Moluccan province. Thus it will be seen that the avifauna of New Guinea is pre-eminently that of the Australian Region, and that it has many peculiar developments of Australian types; but that there has also been an infusion of Malayan forms, of which one group is spread pretty uniformly over the whole Archipelago, if not beyond it; while another group presents a rare instance of discontinuous distribution—not appearing in an intervening space of 1000 miles across, though that space is full of islands to all appearance habitable by such forms. The birds of Papua are, as a whole, remarkable for their brilliancy of plumage, one-half of the species occurring there being so distinguished, and no less than 12 genera are decorated by the metallic colouring of their feathers. The Birds-of-Paradise, the Racquet-tailed Kingfisher, the largest and smallest of the Parrot tribe, namely, *Calyptorhynchus* and *Nasierna*, and the great Crowned Pigeons (*Goura*) are very characteristic among its productions.

The chief dependencies of New Guinea require some little notice. These are the Aru Islands in the west, and New Britain and New Ireland in the east, with the Solomon Islands as still more distant outliers in the same direction, and the Louisiade group in the south. The first, separated by 150 miles of sea from Papua, has over 100 species of Land-birds, of which, however, about four-fifths have been found also on the mainland; but among those which are peculiar are two of the finest *Paradisidae*—one of them belonging to a distinct genus (*Cicinnurus*)—and there is the very suggestive fact, as asserted, of two species of *Casuarus* occurring in the group. Of the ornithological features of New Britain and New Ireland not much is known, save that the former is inhabited by a species of Cassowary, and that both are intimately connected with New Guinea. The avifauna of the Solomon Islands is in some degree better understood, and 30<sup>2</sup> well-authenticated

<sup>1</sup> The importance which must be attached to the distribution of *Ratites* as compared with *Carinatae* birds, to say nothing of the interesting fact that the known number of species of *Casuarus* has been raised from one to nine in the course of a very few years, makes it advisable here to give a list of the 9 species, with the localities (so far as they have been ascertained) they inhabit, as announced to the Zoological Society of London, 16th February 1876, by Mr. Selater, to whose courtesy the author owes the sight of a proof sheet of the communication:—

<i>C. galeatus</i> , Ceram.	<i>C. ptilocollis</i> , Southern New Guinea.
<i>C. papuanus</i> , Northern New Guinea.	<i>C. beccarii</i> , Wokan, Aru Islands.
<i>C. westermanni</i> , Jobie Island.	<i>C. bicarunculatus</i> , Aru Islands.
<i>C. utingipendiculatus</i> , New Guinea.	<i>C. australis</i> , North Australia.
	<i>C. bennetti</i> , New Britain.

A species of Cassowary has been said to occur in the Solomon Islands, and if so, one would think it likely to be distinct, but the only example alleged to have come from that group which has been examined proved to be *C. bennetti*.

It would seem not at all unreasonable that in dividing the Papuan Subregion into provinces we should be guided by the distribution of this remarkable genus. In that case, not only would Ceram be annexed to the Papuan province, but the Cape-York district severed from the Australian and added to the Papuan Subregion.

<sup>2</sup> As stated in the preceding note, a *Casuarus* is said to be found in the Solomon Islands, and, however contrary to expectation, would seem to be of the same species as that which inhabits New Britain.

species of Land-birds, with 1 peculiar *Rallus*, have been found there. Of these 30, 16, or more than half, are known to be peculiar, while 3 more probably are so: 5 species occur in New Ireland as well; 1 is common also to New Caledonia and the New Hebrides, 1 to the Louisiade Archipelago, and the remaining 4 have a wider distribution in the Papuan Subregion, to which unquestionably the group belongs.

The Moluccan province, completing this Subregion and consisting of many rather widely detached islands, which lie for the most part between those forming the provinces already described, extends probably from Timor-land in the south to the Sanguir group in the north, and includes the considerable islands of Ceram, Bouru, Gilolo, and Morty. About 200 species of Land-birds are now known from this province, and they may be assigned to over 80 genera. Of the species about 15 are common to the Indian region, but more than twice as many to the Papuan province, and some 140 are peculiar, of which the most significant are the *Casuarus* of Ceram.<sup>3</sup> Of the genera of Land-birds 2 only—*Semioptera*, a remarkable Bird-of-Paradise, and *Lycocorax*, an aberrant Crow—are peculiar; but there is also in Gilolo a brevipeennate genus of Rails (*Habroptila*) to which the same epithet will apply. One genus is common to Ceram and Celebes, and another is found in Australia, whence possibly it is a migrant, while 30 genera are characteristic of the Papuan Subregion, and nearly 40 more, of more or less wide range, are found in and probably derived from New Guinea. Finally, there are some 12 genera which do not occur in New Guinea, and belong wholly or mainly to the Indian Region, but there are only 3 characteristically Indian types met with in the Moluccas, and all of them are there represented by distinct and well-marked species. The avifauna of the Moluccan province is therefore thoroughly that of the Papuan Subregion, and is no less clearly derivative from that of New Guinea, but not fewer than 11 forms of Birds-of-Paradise (*Paradisidae*), with more than 12 other characteristically Papuan genera, are wanting, and therefore, in Mr. Wallace's opinion, it would seem as though the province is not a fragment of any old Papuan territory, a supposition supported by the fact that most Moluccan birds are very distinct from their representatives in New Guinea. Amongst the most characteristic forms are the scarlet Brush-tongued Parrots (*Lorius* and *Ecus*), found, it is believed, in every island of the group, but not in the Caldesian or Timorese provinces. One species of *Ecus* from Siau and Sanguir intimates that those islands belong to the province. *Eclectus*, another scarlet Parrot, but belonging to a different family, also is equally characteristic with the Parrots just mentioned. As a rule, the birds of the Moluccan province are larger and more conspicuous than the allied species from neighbouring parts.

On the whole, the avifauna of the Papuan Subregion presents some very remarkable features, but most of them must be here briefly treated by way of summary. Unquestionably its most distinctive characteristic is to be found in the presence of the Birds-of-Paradise (*Paradisidae*), which are almost peculiar to it; for, granting that the Bower-birds (*Chlamydera* and others) of Australia should be classed in this family, it must be admitted that they are very abnormal, or perhaps, to take firmer ground, that they are far less highly specialized than the beautiful and extraordinary forms which are found, and found only within very restricted limits, in the various islands of the Subregion. It would be easy, if space allowed, to dwell at length on the many points of interest with respect to those wonderful birds, though in truth we know but little of them.

<sup>3</sup> See preceding footnote.

(2.) *The Australian Subregion* is limited to the great insulated continent which bears that name, with its appendage Tasmania or Van Diemen's Land, and possesses, on the whole, a very homogeneous fauna—so much so, indeed, that at present it would be almost impossible to subdivide it into provinces. Influenced in the north by its proximity to the rich and varied Papuan Subregion,<sup>1</sup> its *ornis* rapidly becomes modified towards the south. Out of some 630 species or more, nearly 490 are Land-birds, and not more than one-twentieth of them are found elsewhere, so that its peculiar species bear a greater proportion to the rest than is the case in the Papuan Subregion. Though the western, and especially the north-western, parts of the country, which have been as yet but imperfectly investigated, will no doubt yield more results on further examination, it is already evident that the greatest animal wealth of Australia lies towards the east. The western portion seems to have but 2 peculiar genera (one of questionable value)—a nocturnal Parrakeet (*Ceopitacus*), and a Weaver-bird (*Emblema*), which is apparently not very far removed from others of the same group. In the north, as already stated, there is a considerable admixture of genera from the Papuan Subregion, which do not proceed beyond the tropic, and of these *Casuarinus* is a striking example. The genus *Xerophila*, of uncertain affinity, is confined to South Australia; and the extreme limits of the Subregion, that is Tasmania, possess in addition only 1 genus, *Eudypis*, belonging to the marine family of the Penguins (*Spheniscida*), which inhabit generally the sub-antarctic seas; but the Land-birds, which are few in number, are specifically identical with those of Australia proper. This is even the case with the Emeu (*Dromasus*), and the import of this fact is as significant<sup>2</sup> as would be a corresponding example drawn from the class *Mammalia*, since, in regard to means of locomotion, birds incapable of flight are on a par with terrestrial mammals. As a whole, Australia is rich in Parrots (*Pittacidae*), having several very peculiar forms; but Picarions (*Picaria*) of all sorts—certain Kingfishers (*Alcedinidae*), perhaps, excepted—are few in number, and the Pigeons (*Columbidae*) are also comparatively scarce. Australia, however, possesses two extraordinary families of abnormal *Passeres*—the Lyre-birds (*Menuridae*) and the Scrub-birds (*Atrichidae*)—which, so far as is at present known, stand by themselves, though it is possible that the latter have a somewhat distant ally in the genus *Orthonyx*, or even in the South-American family *Pteropochida*. The number of peculiar or characteristic genera of *Passeres* is, however, too great to be here enumerated; and there are many singular forms of *Columbidae*. Among the more curious forms of Land-birds other than those may be especially remarked *Lipos* among the *Gallinae* (*Meypodidae*), and *Tribonyx* among the *Grallae* (*Ballidae*), while *Pedionomus* is a form referred by some systematists to the first and by others to the second of those Orders. The presence of a Bustard (*Eupodotis*) presents a curious example of interrupted distribution, since none of that family (*Otididae*) are found nearer than India.

(3.) *The Polynesian Subregion*, though so vast, extending as it does from one tropic to the other throughout ninety degrees of longitude (from long. 140° E. to long. 130° W.), at that part of the earth's surface where degrees of longitude are broadest, possesses generally a very uniform avifauna. It may possibly be partitioned into four or five provinces; but if so, the products of the first of them,

containing the Palau<sup>3</sup> (commonly called Pelew), the Caroline, and most likely the Ladrone Islands, are at present too imperfectly known for any useful results to be drawn from them. Then we have the New Hebrides and New Caledonia forming another province; after which comes the third, or Central-Polynesian province, comprising the Fijian, Tongan, and Samoan groups; next the numerous clusters from Cook's Islands to the Marquesas, including the Society Islands and the whole of the Low Archipelago, which may perhaps form a fourth province; and lastly, the Sandwich or Hawaiian Islands. The first of these provinces (so to call them) possesses in the Palau Islands a Reed-Warbler, which seems to form a peculiar genus (*Peamathia*), while another kindred form belongs to the widely-spread genus (*Acrocephalus*) that our own English bird does, and occurs there, and there alone, so far as we know, throughout the whole Subregion.<sup>4</sup> The like may be said of a Goatsucker (*Caprimulgus*). 1 other typically Polynesian genus is found; 1 is common to the Papuan, and 1 to the Malayan (Indian) Subregion. The second province shows some transition from the Papuan to the Australian Subregion. Out of 30 genera of Land-birds, 18 are typically Australian, 13 are also Polynesian: about 5 go no further to the eastward. 3 species of *Aplonis*, a genus of uncertain affinity, but generally classed with the Starlings (*Sturnidae*), seem to link this province to the Central-Polynesian, and a very remarkable and apparently very generalised form of *Gralla*—the Kagu (*Rhinoceros*), which seems to have half-a-dozen scattered alliances—is peculiar to New Caledonia. From the third province only some 50 genera and some 150 species of Land-birds are known. A species of Cuckoo (*Eudynamis taitensis*) ranges over the whole of this as well as the next district so far as the Marquesas, as also does perhaps an abnormal Warbler (*Tatara*). On the other hand, the Samoan group has in the Manu-mea or Tooth-billed Pigeon (*Didunculus*) a form which alone makes a distinct family of *Columbae*;<sup>5</sup> and another island of the same group, Savai, produces a most peculiar brevipeonate Water-hen (*Parouhiastes*), which it deemed worthy of generic separation from *Gallinulae*. The fourth province, which (if it may be recognized as such) may be called the Eastern-Polynesian, comprehends, as above stated, the countless islands which surround the Low Archipelago. Respecting these we have little precise information—two meagre lists of birds from Huahine, one of the Society group, and a catalogue obviously not complete of those of the Marquesas, appearing to furnish nearly all our available material. The latter group possesses a rather remarkable Pigeon, said to be peculiar to it, but perhaps also found in the former; and though closely allied to *Carpophaga*, it has been elevated to generic rank under the name of *Serrisius*. The last province is that of the Sandwich Islands, which, notwithstanding that their ornithology has never been thoroughly worked out, seem to present some conspicuous differences from any other; and it is almost a matter of opinion whether, small as is the known avifauna of the group, it should not be regarded as constituting a separate Subregion rather than as a province of Polynesia. The ascertained Land-birds are but 18 in number. Of these 3 are Birds-of-prey, and 1 of them, the *Pandion* (?), *solitarius* of Cassin, is only known in collections by a unique specimen. The other 3 are widely-distributed

<sup>1</sup> The Peninsula of Cape York possesses a *Casuarinus*, as already noticed, and other grounds are not wanting for the supposition that has been entertained that zoologically it belongs to the Papuan Subregion.

<sup>2</sup> Its significance is increased by the fact that the Emeu of West Australia is distinct from that of the east. The Emeu is extinct in Tasmania.

<sup>3</sup> Dr Finsch is understood to be especially engaged on the birds of this group of islands, to our knowledge of which he and Dr Hartlaub have already contributed much.

<sup>4</sup> It is, however, found in Australia, and even in the south of that country.

<sup>5</sup> It is possible, however, that *Otidiphaga*, which is supposed to come from New Guinea, may also belong to the *Didunculidae*.

species of Owls (*Strigida*). There are no *Psittaci* or *Picaria*. The *Passeres* consist of 15 well-established species, all peculiar to the group, and belong to 10 generic forms, only 1 of which, the cosmopolitan *Corvus*, is known to occur elsewhere. The remainder are restricted to the Hawaiian Islands, and may be referred to 2 families—one the almost universally distributed Flycatchers (*Muscicapida*), and the other the Honeyeaters (*Meliphagida*), which, as has been said before, are preeminently characteristic of the whole Australian Region; but it is to be observed that the most of the species are remarkable for the extraordinary form of their bill, so that they may ultimately be found to constitute a special section of the family, if they be not considered to form a distinct one (*Drepanida*). There are also two peculiar species of Water-birds—a Coot (*Fulica alae*), and the well-known Sandwich-Island Goose (*Bernicla sandwichensis*), which has been very commonly domesticated in Europe. The Hawaiian Archipelago has thus a larger proportion of peculiar genera and species than any other group in the Subregion, from which fact Mr Wallace infers, and no one can doubt the truth of the observation, the great antiquity of its isolation.

(4.) *The New-Zealand Subregion*, however, is, and to all appearance long has been, more isolated still, probably, indeed, longer isolated than any other portion of the globe. Beside the three larger islands, known in the aggregate as New Zealand, numerous satellites belong to the Subregion, as Lord Howe's, Norfolk, and Kermadec Islands, with the Chatham, Auckland, and Macquarie groups. At the highest estimate the Subregion contains about 150 existing species of birds, of which more than 60 are Land-birds, belonging to about 34 genera, 16 of the latter being peculiar, and there may be some 5 genera of Water-birds, making 21 in all. Of the others 4 are widely spread, but the rest (9 in number) are characteristically those of the Region. Most of the genera occurring elsewhere are here represented by peculiar species, but then 5 are common to Australia. Some 7 or 8 are also allied to Australian species, and there are 4 Australian and 1 Polynesian species. Therefore every degree of similarity to Australia is to be found. Of peculiar genera it will suffice to say that 2 (*Myzomela* and *Miro*) belong to the Warblers (*Sylviida*), 1 genus (*Turnagra*) perhaps comes under the Rabblers (*Timaliida*), and 2 genera (*Amicus* and *Acanthopitta*) may be referred to the Cuckoos (*Certhiida*). The *Porida* have 1 genus (*Certhiiparus*), and the *Meliphagida* 3 genera (*Prothemadusa*, *Pogonornis*, and *Anthornis*). The Starlings (*Sturnida*) are represented by *Callaea*, *Creadion*, and the very abnormal—or perhaps it would be better to say generalised—*Heterolocha*. An entire and very distinct family (*Strigopida*) of Parrots is certainly peculiar, and it may probably be justifiable to regard the genus *Nestor* as constituting a second. There is also an Owl, which has been usually considered the type of a genus (*Sceloglaux*); and the *Ballida* present two very remarkable forms—the Wood-hens (*Ocydromus*) and the Takahē (*Notornis*), the last almost, if not quite, extinct. The widely-spread family of Flowers (*Charadriida*) have two not less singular generic developments—*Thinornis* and the extraordinary Wrybill, *Anarhynchus*. Among the Ducks (*Anatida*), *Hymenolaimus* is a very curious form; and, finally, among the *Ratitae* we have the whole family of weird-looking Kiwis (*Apterygida*), represented by three or four species, which are totally unlike any other existing birds. In all, there is a wonderful amount of specialisation, though perhaps in a very straight line from generalised forms; but the affinity to Australian or Polynesian types is in many cases clearly traceable, and it cannot be supposed that these last are of cognate origin with those of New Zealand. A very long period of isolation must have been required to produce

the differences so manifestly to be observed, but a few forms seem at rare intervals to have immigrated, and this immigration would appear to be kept up to our own day, as shewn by the instance of *Zosterops lateralis*, which is said to have lately made its first appearance, and to have established itself in the country, as well as by the fact of two Cuckoos, the widely-ranging *Eudynamis taitensis* and *Chrysococcyx lucidus*, which are annual visitors.

The most extraordinary ornithic feature of New Zealand, however, is unquestionably the former existence of the gigantic birds of the families *Dinornithida* and *Palaeopterygida*, with a few other contemporary forms. These, however, having been already mentioned there is no need to dwell further upon them. As a whole, the avifauna of New Zealand must be regarded as one of the most interesting and instructive in the world, and the inevitable doom which is awaiting its surviving members cannot but excite a lively regret in the minds of all ornithologists. This regret is quite apart from any question of sentiment; if it were otherwise, it could not be defended against that sentiment which prompts our colonial fellow-subjects indiscriminately to stock their fields and forests, not only with the species of their mother-country, but with all the fowls of heaven, whencesoever they can be procured. The regret we express arises from the thought that just as we lament our ignorance of the species which in various lands have been extirpated by our forefathers, so our posterity will want to know much more of the present ornithology of New Zealand than we can possibly record; for no one nowadays can pretend to predict the scope of investigation which will be required, and required in vain, by naturalists in that future when New Zealand may be one of the great nations of the earth.

II. THE NEOTROPICAL REGION, though presenting certain affinities to the Australian, and the only one which can be said to be zoologically allied to it, is yet almost as distinct in its character therefrom as it is geographically distant. Excepting towards its northern limits, where it meets and inoculates with the Nearctic Region, the boundary of the Neotropical Region is simple enough to trace, comprehending as it does the whole of South America from Cape Horn to the Isthmus of Panama and all Central America, and reaching in North America to somewhere about the twenty-second parallel of north latitude; besides including the Falkland Islands to the south-east,<sup>1</sup> and the Galapagos under the equator to the west, as well as the whole of the Antilles or West-India Islands up to the Florida Channel, which separates them from the peninsula of that name. Though over none but the remotest corners of this sufficiently large area is the supreme Class of animals formed (as we have found it to be the case throughout by far the greater portion of the Australian Region) by the Birds, yet they here play a part of very great importance, owing to the comparatively scanty number of Mammalian types. Among these last, however, there are two remarkable groups—the *Pedimana*, containing the only members of the Subclass *Didelphia* which occur at the present day

<sup>1</sup> It may even be questionable whether Tristan da Cunha, though lying nearer to the African coast, should not be referred to the Neotropical rather than to the Ethiopian Region. On this lone spot but four species of Land-birds are known to occur, all of which are peculiar—two of them even generically. One is a Finch (*Orithya islandica*), belonging, it is true, to a genus very well represented in Africa; but the second (*Neosylvia aculeata*) is the type and sole member of a genus which, whether it be considered a Finch or a Bunting, is said by Dr Cabanis, its describer, to have unquestionable similarity to some South American forms (*Journal für Ornithologie*, 1872, p. 154). The third bird is a Thrush (*Neocichla eremicus*), like the last, peculiar both in species and genus to the island, and apparently having no relation to anything Ethiopian; while the fourth is a peculiar species of bristly-necked Water-bird (*Gallinula neotitica*), which may have been derived from either continent.

out of the Australian Region, and the *Edentata*, an Order which, though found also in Africa and India, attains in South America the summit of its development in variety and number of forms; and we cannot adduce any examples of Orders or Suborders from the Class *Aves*, the circumstances of which will exactly match those of these three groups of *Mammalia*. The nearest approach, perhaps, is made in one way by the South-American Ratite birds, of which one entire group, consisting of at most three species (*Rhoida*), is peculiar to the region, and thus to some extent parallels the case of the *Podiceps*; but while these last also invade the Nearctic Region, the former are not even spread over the whole of continental South America, being limited to its colder portion. Moreover, so far as Orders have been generally understood and accepted by ornithologists among Carinate Birds, there is no one of wide range which can compare with the overwhelming development of the *Edentata* in the Neotropical Region. On the other hand, it must be observed that the Region claims all the Tinamous (*Tinamidae*)—the *Dromocynthus* of Professor Huxley—which, if we were to follow his arrangement established on palatal characters, it would seem necessary to regard as the equivalent of an Order; and also a single very remarkable form (*Opiathocornis*), which he has satisfactorily shown to be so unlike every other that it can only be conveniently classed by itself.<sup>1</sup> Of these forms the *Tinamidae* certainly, and *Opiathocornis* probably, are of comparatively low developmental rank, in that respect resembling certain characteristic Australian groups; but the similarity between the avifaunas of the two Regions seems to be further borne out by the same fact being observable of other South-American families, forming what may be called the lower Suborders<sup>2</sup> of *Passeres*, to which the names of *Oligomyzoda* and *Trachophona* have been attached, and these, if not altogether originating in the Neotropical Region, are without doubt therein most abundantly produced. The significance of this fact is enhanced when we remember that, as has been said before, to consider rightly the problem of the distribution of birds, we must in the main rely on the *Passeres*, as affording on the whole the surest ground for our investigations. Now, taking the latest, nay, the only, complete list of Neotropical birds—that published by Messrs Sclater and Salvin<sup>3</sup> in 1873, we shall see that there are 8 Passerine families peculiar to the Region, of which 3 belong to the *Trachophona*, 4 to the *Oligomyzoda*, and 1 only to the *Polymyza* or *Oecina*. Or, if we look to the entire number of species given in that work as inhabiting the Region, we find it to be 8565. Of these, 1997, or a good deal more than half, belong to the Order *Passeres*—a large proportion truly, but one that (from other causes not germane to our present investigation, and therefore to be just now disregarded) need not especially excite our wonder. But the characteristic nature of the avifauna of the Region is more clearly brought out when

<sup>1</sup> To recognize these Orders, *Cryptus* and *Opiathocornis*, however, it becomes logically necessary to recognize many other groups in like manner, and thus to raise the number of Orders in the whole Class to at least two dozen, or nearly four times as many as most ornithologists have been usually willing to admit, a proceeding which naturally lowers the differential standard, and renders a comparison between "Orders" of *Aves* and "Orders" of *Mammalia* or *Reptilia* almost impossible.

<sup>2</sup> The term "Suborder" should very possibly not be used here, at least in a technical sense. The *Passeres* seem to be properly divisible into two great groups—one containing the genus *Messers*, the other all the rest, except most likely *Atrichia*, which there is some reason to suppose may be found to form a third group. Whenever these groups shall receive names, they ought to be regarded as Suborders, but in the meantime, with this explanation, perhaps no harm will follow from calling the sections *Polymyza* (the *Oecina* of some writers), *Oligomyzoda*, and *Trachophona* "Suborders."

<sup>3</sup> *Monomelator Avium Neotropicalium*, &c., Annotibus P. L. Sclater et G. Salvin. Londini: 1873.

we learn that of the 1997 species just mentioned, 1070 only belong to the higher Suborder (*Polymyza*), leaving 927 to the two lower Suborders (*Oligomyzoda* and *Trachophona*); or to speak in round numbers, out of 3000 species of the highest Order of birds, a little more than one-half belong to its highest section, while nearly one-half belong to its two lower sections. This is a state of things which exists nowhere else on the globe; for, except in Australia, where a few but uncertain number of purely indigenous and peculiar non-polymyzoan *Passeres* are found, and in the Nearctic Region whither one family of *Oligomyzoda* has evidently been led by the geographical continuity of its soil with that of the Neotropical Region, such forms do not occur elsewhere. Accordingly their disproportionate prevalence in South America and its neighbouring lands points unerringly to the lower rank of the ornis of the region as a whole, and therefore to the propriety of taking it next in order to that of the Australian Region, the general fauna of which is admittedly the lowest in the world. It is believed that much the same result would follow from a similar examination of other Orders, especially the *Picaria*; and Professor Huxley has urged with his wonted perspicuity the alliance of the two Regions just named, basing his opinion in great measure on the evidence afforded by the two sections into which the true *Gallinae* are divisible, the *Parietropodes* and the *Alectoropodes*, the former composed of the families *Megapodiidae*, almost wholly Australian, and the *Cracidae*, entirely Neotropical, but citing also other weighty evidence in favour of his conclusion.<sup>4</sup>

Leaving, however, this matter as in some degree hypothetical, though its probability can hardly be denied, we have as genera, families, or perhaps even larger groups a great many very remarkable forms which are characteristic of or peculiar to the Neotropical Region in part, if not as a whole. Of families we find 23, or maybe more, absolutely restricted thereto, besides at least 8 which, being peculiar to the New World, extend their range into the Nearctic Region, but are there so feebly developed that their origin may be safely ascribed to the southern portion of America. First in point of importance comes the extraordinarily beautiful family of Humming-birds (*Trochilidae*), with nearly 120 genera (of which only 5 occur in the Nearctic Region), and more than 400 species. Then the Tyrants (*Tyrannidae*), with more than 70 genera (8 of which range into the northern Region), and over 300 species. To these follow the Tanagers (*Tanagridae*), with upwards of 40 genera (only 4 of which cross the border), and about 300 species; the Piculules (*Dendrocolaptidae*), with as many genera, and over 200 species; the Ant-Thrushes (*Formicariidae*), with more than 30 genera, and nearly 200 species; together with other groups which, if not so large as those just named, are yet just as well defined, and possibly more significant, namely, the Tapaculos (*Petrochelidonidae*), the Toucans (*Rhamphastidae*), the Jacamars (*Galbulidae*), the Motmots (*Momotidae*), the Todies (*Todidae*), the Trumpeters (*Psephenidae*), and the Screamers (*Palmamedidae*); besides such isolated forms as the Screechers (*Cariacus*) and the Sun-Bittern (*Eurypyga*).

Having thus briefly indicated some of the chief characteristic and for the most part generally distributed forms of the Neotropical avifauna, we have next to consider the separation of the Region into Subregions and provinces. Herein we find far greater difficulty than we had to encounter in treating of the preceding (the Australian) Region, the geographical peculiarities of which marvellously lend themselves to its comparatively easy partition, while the isolation of its several portions contributes in an extraor-

inary degree to the process. But compared with the remaining Regions of the globe, the Neotropical, as it will be essayed to show in the sequel, presents, perhaps, no greater difficulty in this respect than others do. The Subregions (one excepted), however, cannot be said to be well defined, for no natural boundaries are to be found for them, and we must trust solely to the presence or absence of certain forms of Bird-life in marking out their limits. This is, of course, the most proper zoological method of proceeding, but in some cases it tends to make the divisions rather more than less arbitrary, and in all cases dependent upon the amount of investigation which has been bestowed on the several districts. The physical features of the continent of South America are very varied, and cannot be said to assist us much or at all in our task. The proximity of its southern extremity to an ocean wherein at one season of the year floating ice abounds, gives that portion a rigorous climate, and the presence of the grand chain of the Andes, the highest save one in the world, prolongs beyond the equator those characteristics of a mountainous or even an alpine tract, which override any that are commonly associated with degrees of latitude. This range, the great Cordillera, has also a remarkable effect first on the climatological properties of the whole country, and then on its vegetation, which, of course, acts directly on its animal inhabitants. Running as the Andes do pretty nearly longitudinally, and lying near the western coast of the continent, the warm, moist winds from the Atlantic sweep across its eastern and wider portion, unimpeded in their course by any considerable high land, till they are attracted by the summits of the giant range, and, precipitating their fertilizing showers on its lofty slopes, supply the brimming floods of some of the largest rivers of the world. Westward of the chain is in great part a desert, at least down to lat. 10° S., though much of this was, prior to the conquest of Peru by the Spaniards, carefully irrigated and highly luxuriant. A few other arid tracts are found, but compared with most other continents the proportion of desert-land is small, and the valleys of the majestic rivers which roll their course to the Atlantic are clothed with the most extensive virgin forests in the world. To these varied physical conditions seem due the chief differences which are observable in the avifauna of the component parts of the South-American continent, which, rich as it is beyond that of all other countries in genera and species, displays yet a considerable uniformity in its larger groups of Birds.

The Subregions into which that portion of the earth at present under consideration can be most conveniently separated seem to be six in number—four of them included within the continent of South America, and two lying beyond its limits.<sup>1</sup> But the confines of these continental Subregions, as has been above hinted, are of the vaguest. It is doubtful whether any amount of local knowledge will ever justify the zoogeographer in drawing an absolute line of demarcation between any two of them. At present our information certainly does not permit us to do more than indicate the general direction of such boundaries; not that we believe that their existence may not be legitimately assumed. Beginning with the apex of the continent, we have a Subregion, extending from Cape Horn to somewhere north of Bahía Blanca on its eastern coast, whence its boundary runs in a north-westerly direction, passing to the eastward of Mendoza, and then northward along the eastern and higher slopes of the Andes until it crosses the equator,

<sup>1</sup> In arriving at this conclusion the author wishes to acknowledge the kind assistance he has received from his old friend Mr Salvin, F.R.S., whose long-continued study of American, and especially Neotropical, forms of birds has placed him in the front rank of authorities on the ornithology of the New World.

and, after trifurcating on either side of the valleys of the Magdalena and its confluent the Cauca, returns along the western slopes of the lofty Cordillera, until it trends seaward and reaches the Pacific coast of South America somewhere about Truxillo, in lat. 7° S. This Subregion, for a reason presently to be given, may be called the Patagonian, though its northern extremity lies so far removed from its eponymic territory. Next we have what may be called the Brazilian Subregion, marching with the foregoing until somewhere near Potosi in Bolivia, whence it turns to the north-east, and, avoiding the watershed of the Amazons, strikes, perhaps, the Paranahyba, through or along which it makes its way to the Atlantic. Then comes the enormous basin of the Amazons—the Mediterranean of South America, as the dwellers on its banks fondly call it—which, though forming an important part of the Brazilian Empire, seems undoubtedly to be a distinct Subregion from that to which this last name has been applied, and may justly be denominated the Amazonian. Yet, be it remembered, that its peculiarities not being observable on the higher tributaries of the mighty river, its upper waters must be regarded as draining land which belongs to the fourth Subregion—of which more immediately. Continuous to the southward with the Brazilian boundary the western frontier of the Amazonian Subregion seems to turn off before the eastern confines of the Patagonian Subregion are reached, and, leaving a space intervening, it pursues a generally northward course, at a lower level, on the western bank of the Huallaga, and crossing the great stream whence it derives its name, in somewhere about long. 77° W. and lat. 5° S., it pursues its way towards the mouth of the Orinoco. The fourth and last Subregion of South America includes all that is left of the continent, and perhaps may be most fitly named the Subandean.<sup>2</sup> This begins in the south with the narrow slip of land before mentioned as intervening between the comparatively low-lying Amazonian Subregion and that portion of the Patagonian which runs along the lofty Peruvian Andes, and is believed to extend from the frontiers of Bolivia to the table-land of Ecuador, rounding, on the one hand, the forked extremity of the Patagonian Subregion to the westward until it meets the Pacific at Truxillo, stretching over 500 miles of sea to the Galapagos Islands, under the equator, and, on the other hand, following the Amazonian boundary to the Atlantic, while it comprehends the islands of Trinidad and Tobago, as well as those which lie on the northern coast of South America. Besides portions of the states already named, it includes Nueva Granada and Venezuela till it reaches the Central-American Subregion in the Isthmus of Panama. This fifth Subregion stretches on the west northward about as far as Guaymas on the east coast of the Gulf of California, and on the east to the Rio Grande, which forms the boundary of Mexico and Texas, but the Nearctic Region dips down along the central table-land till near Queretaro, a little to the northward of the city of Mexico, and thence southward along the higher ridges to an almost indefinite extent. The sixth Subregion is composed of the Antilles, with the important exception of Trinidad and Tobago, and its limits being capable of easy geographical circumscription, further consideration of them may be for the present deferred.

The difficulty of distinguishing these several Subregions is indeed very great; and it is not only possible, but highly probable that even in a few years further exploration will enjoin a large amount of rectification of their frontiers. It

<sup>2</sup> In some respects it corresponds with what has been commonly called the "Columbian" Subregion; but that name, having been used in a special and more restricted sense, might give rise to some misunderstanding. As will be seen, it comprehends far more than the former United States of Columbia.



must be remembered too that where, in the preceding paragraphs, "lines" of demarcation have been spoken of, such lines are in truth tracts of country often from one to two hundred miles in breadth, and in most cases there is no hope that the boundaries will ever attain any great degree of precision. Some advances of knowledge in this direction will no doubt accrue as the elevation and contour of hills and table-lands become more accurately laid down; but at first the effect of this increase to our information will certainly be to complicate matters, by shewing the existence within one Subregion of spurs, isolated spots, or enclosed areas belonging to another, and as yet unsuspected. Still the amount of light thrown on the Neotropical Region by the persevering labours of the eminent ornithologists before named, seems to deserve being brought to a focus; and accordingly the following summary is now offered in the hope that some of the characteristics of the avifauna of the Region may thereby be more readily comprehended.

Of the families of Birds peculiar to the Neotropical Region—twenty-four in number, according to Messrs Salater and Salvin—the distribution may be tabulated as follows:—

Subregion.	Peculiar to 1 Sub-region.	Common to 2 Sub-regions.	Common to 3 Sub-regions.	Common to 4 Sub-regions.	Common to 5 Sub-regions.	Common to all Sub-regions.
Patagonian .....	1 <sup>1</sup>	3	1	1	3	0
Brazilian .....	0	4	1	8	5	0
Amazonian .....	1	0	1	3	5	0
Subandean .....	1	1	2	3	5	0
Central-American .....	0	1	1	7	5	0
Antillean .....	1	0	0	0	2	0

This table will serve to shew the close alliance of the four middle Subregions to one another in their most remarkable forms, and, at the same time, the singularity displayed by the Patagonian and Antillean Subregions; while it will also make evident that no family peculiar to the Region is found in all its Subregions.

(1.) *The Patagonian Subregion*, lying chiefly at the southern extremity of the continent, seems to present the greatest affinity to that in which the Australian avifauna reaches its climax. This is shewn not only by the prevalence in it, alone of all the Neotropical Subregions, of the *Ratites*, which wander over its solitudes, and the Penguins (*Spheniscidae*), which haunt its shores; but by the low, generalized, and peculiar forms like *Thinocorus* and *Attagis* among the widely-varying *Limicolæ*, and the *Pteroptochidae* (though some few species of this family occur elsewhere in South America) among the *Passeres*. The family of Plantcutters (*Phytotomidae*) is almost peculiar, only just intruding upon Southern Brazil. Of the more characteristic families of Birds of the New World, some 3 only (*Dendrocolaptidae*, *Formicariidae*, and *Trochilidae*) shew themselves in any great abundance, while but 2 others, which are feebly represented, occur within the ill-defined limits of its southern province, Patagonia,—the rest of its terrestrial, and still more of its littoral or maritime, avifauna consisting of families, or groups of families, which are nearly cosmopolitan. On the pampas of La Plata we find the number of characteristic Neotropical forms much increased, but still the poverty of the Argentine ornis is of the most marked kind when compared with the wealth of the more fertile tracts which lie on its northern and eastern frontiers. In La Plata we have but 2 other families (*Tyrannidae* and *Palamedidae*) coming under this category that are at all well developed. *Mniotiltidae*, *Vireonidae*, and *Corvidae* do not appear at all, and *Tanagridae* but in small numbers. As has been said already, the Subregion extends northward along the chain of the Andes, and with this extension it

seems proper to take in their arid and barren western slopes as well as a portion of the tract lying between that range and the sea, so as to include Chile and a considerable slice of Peru. But even by so doing we gain but little. No more of the characteristically Neotropical forms mount these lofty ascents in any multitude, nor are we able to add any forms of very wide distribution. However, throughout the whole Subregion many genera, and species without number, which are absolutely peculiar, occur, and thus aid in stamping the quality of the tract. Indeed, the very presence of the Struthious family *Rheidae*, with its two or three species, would serve alone to do this; and as its headquarters are in Patagonia, that country becomes of sufficient importance to give its name to the Subregion of which it forms at most but a moiety.

Entering more into details, we find the Patagonian Subregion possessing about 46 genera of birds not found elsewhere in South America. Of these 30 are strictly Land-birds—3 belonging to the family *Emberizidae*, 1 to *Icteridae*, 5 to *Tyrannidae*, 8 to *Dendrocolaptidae*, 4 to *Pteroptochidae*, 3 to *Trochilidae*, 1 to *Pittacididae*, 1 to *Falconidae*, 1 to *Columbidae*, 2 to *Tinamidae*, and 1 to *Rheidae*. Of the rest there are 3 genera of *Charadriidae* (as restricted), 1 of which (*Eudromias*) is doubtfully identical with a genus of the Old World; 2 genera of the peculiar family *Thinocoridae*; *Chionis*, an antarctic form; 2 genera of *Scelopacidae*, one peculiar, the other (*Rhynchaea*) rather widely spread over Australia, India, and Africa; 2 genera of *Anatidae*, both peculiar; 2 genera of *Laridae*, one peculiar, the other belonging to subpolar seas; 1 genus of the cosmopolitan *Podicepsidae*; and 3 genera of *Spheniscidae*, a family limited to the Antarctic or Subantarctic Ocean. But further into particulars want of space forbids our going, save to remark on a very peculiar and instructive case offered by Humming-birds there are three known species—*E. galaritus*, found in Chile, evidently its mother-country, but also occurring from 400 to 600 miles from the mainland on both of the chief islets of the little Juan-Fernandes group—*Masafuera* and *Masafuera*; but each of these limited spots has besides its own peculiar species of the genus—the former *E. fernandensis* and the latter *E. leyboldi*. This alone would present nothing at all unparalleled elsewhere; but it is curious that while both sexes of the more widely-ranging *E. galaritus* have a green plumage, the males of the other two have a brilliant red colour, and generally resemble each other, though the females of each differ more decidedly. Supposing, as we may justly do, that all these species have descended from a common ancestor, Mr Salater has shewn<sup>2</sup> the probability that *E. galaritus* represents the appearance of the parental stock that in bygone times colonized the Juan-Fernandes cluster, of which *E. fernandensis*, now peculiar to *Masafuera*, and the most aberrant from the original form, is the progeny of the earliest settlers, and *E. leyboldi*, confined to *Masafuera*, is the descendant of a later immigration, while, still more recently, *E. galaritus* has found its way to both islets, and in each yet possesses its normal characters.

Passing over, as not-affording anything especially remarkable, the chain of islands, from Chiloe to Cape Horn, in which the range of the Andes plunges into the Southern Ocean, though alongside of it lie Tierra del Fuego and its satellites, which form an important adjunct to the South-American continent, our attention is turned to the Falklands, an interesting and considerable group of islands situated over 200 miles to the north-east of the historic Strait of Lemaire. Here we find 18 species of Land-birds—7 belonging to the order *Accipitres* and 11 to *Passeres*. Of

<sup>1</sup> The *Thinocoridae* may be questioned as having a real existence. The writer would be inclined to include it in the cosmopolitan family of *Charadriidae*.

<sup>2</sup> *Ibid.*, 1871, pp. 180-183.

than the latter. But the affinities of its Reptilian fauna point to a connection, however remote in point of time, with South America, and accordingly the Galapagos are here left in that Region to which they have been commonly assigned.

(5.) *The Central-American Subregion* is the next to be considered, and in treating of it we become aware of a disturbing force which renders impossible the laying down for it of anything like a definite frontier. This disturbing force is the entrance, as before intimated, of a Nearctic fauna which runs along the backbone, so to speak, of the Subregion to an unknown but variable extent; for part of this Nearctic fauna ebbs and flows according to the season of the year, in winter possibly creeping down the mountainsides, and being strongly reinforced by immigrants from the north, but in summer retiring northward and perhaps upward, so as to occupy only the most lofty ridges. Yet that two Subregions here unite and inosculate is certain; but in considering the Central-American avifauna, we have to guard ourselves against this periodic stream of northern immigrants, and cannot deal with it precisely in the same way as we have done those Subregions further removed from the influence which is here so strongly manifested. In Central America, though its ornis is of the richest, we find not a single peculiar family of Birds, and those which it, to a more or less limited extent, shows with the other Subregions of the Neotropical Region have been already named, except the *Ampelida*, a small but widely-ranging family of the northern hemisphere, which it has in common with the Antillean Subregion. 5 other families, however, *Parida*, *Sittida*, *Certhida*, *Laniida*, and *Melagrida*, belonging also to the Nearctic Region, occur here. Of genera which are not found elsewhere in the Region, it seems to have 93, but 47, or just more than half, of them are also found in the Nearctic Region; and therefore to obtain anything like a true notion of the Central-American ornis, it will be necessary to keep the two categories apart. Taking first those which are absolutely peculiar, we have 2 belonging to *Turdida*, 1 to *Troglodytida*, 2 to *Mniotiltida*, 1 to each of *Vireonida*, *Ampelida*, and *Tanagrida*, 3 to *Emberinida*,<sup>1</sup> 1 to *Icterida*, 2 to *Corvida* and *Tyrannida* respectively, 1 to *Cotingida*, 2 to *Formicariida*, 19 to *Trochilida*, 2 to *Momotida*, 1 to each of *Tragonida*, *Ouculida*, and *Pittacida*, 2 to *Oracida*, and 1 to *Tetraonida*. Then, taking those not found elsewhere in the Neotropical Region, but inhabiting the Nearctic, we have, as occurring in Central America, 1 belonging to *Turdida*, 2 to *Sylviida*, 3 to *Parida*, 1 to each of *Sittida* and *Certhida*, 2 to *Troglodytida* and *Mniotiltida* respectively, 1 to *Laniida*, 2 to *Ampelida*, 14 to *Emberinida*,<sup>1</sup> 3 to *Fringillida*, 2 to *Icterida*, 1 to each of *Tyrannida*, *Trochilida*, *Picida*, and *Cuculida*, 2 to *Strigida* and *Anatida* respectively, 1 to each of *Columbida* and *Melagrida*, 2 to *Tetraonida*, and 1 to *Charadriida*.

Nicely balanced as these numbers are, they show a result which might well have been expected from the physical and geographical configuration of the country, while the numbers of other families peculiar to the Neotropical Region, though shared by some of its Subregions, as already given, prove incontestably the propriety of including Central America with that Region; and this would come out even more plainly did our limits permit of the investigation being extended to species, though so many northern forms here find their winter-quarters. It remains to remark that almost the only island of any importance belonging to the Subregion is Socorro; the largest of a small group lying to the westward of Mexico in lat. 18° 30' N., and long. 111° W. Here out of 9 species of Land-birds, 4 have been described as peculiar, 2 others are

elsewhere known as occurring only on the Tres Marias, a little group some 250 miles nearer the mainland, and 1 is regarded as a local race of a continental species, leaving but 2 (both Birds-of-prey) which cannot be deemed autochthonous. The still more remote Cocos Island, lying in lat. 5° 33' N., and long. 87° W., from which one peculiar species of *Coccyzus* (*Cuculida*) is known, may belong just as likely to the Subandean as to the Central-American Subregion.

(6.) *The Antillean* is the only one of the Neotropical Subregions the precise boundaries of which can be definitely laid down; and it is in many respects one of the most suggestive and interesting, comparatively small though it be. Extending from Cape San Antonio de Cuba in the west to Barbadoes in the east, its greatest length is only about 1700 miles, and from Abaco, one of the Bahamas, in the north to Grenada in the south, it does not cover 15 degrees of latitude, while within these limits the proportion of land to water, being less than 98,000 square miles, is very inconsiderable. The unbroken chain of islands which are commonly known as the "West Indies"—though that term rightly includes not only all of the "Spanish Main," but an indefinite extent of coast lying both north and south of the ancient dominions of the Catholic King in the New World—forms, geographically, a second line of connection between the two halves of the American continent, separated from the great western isthmus by the deep waters of the Caribbean Sea and the Gulf of Mexico, and at once suggests a former communication by land with Yucatan at the one extremity and with Venezuela at the other, to say nothing of a possible junction with Florida. Yet, as will presently be shewn from a consideration of the peculiar forms of Bird-life which have grown up along the chain, any such communication, if it ever existed, must have been exceedingly remote in point of time; for narrow as are the channels between Cuba and the opposite coast of Central America, between the Bahamas and the south-western peninsula of North America, and between Grenada and Tobago (the last belonging zoologically, as has been already demonstrated, to South America), the fauna of the Antillean chain, instead of being a mixture of that of the almost contiguous countries, differs much from all, and exhibits in some groups a degree of speciality which may be not unfitly compared with that of oceanic islands. Except such as are of coral formation, the Antilles are hilly, not to say mountainous, their summits rising in places to an elevation of 8000 feet, and nearly all, prior to their occupation by Europeans, were covered with luxuriant forest, which, assisting in the collection and condensation of the clouds brought by the trade winds, ensured its own vitality by precipitating frequent and long-continued rains upon the fertile soil. Under such conditions we might expect to find an extremely plentiful animal population, one as rich as that which inhabits the same latitudes in Central America, not many degrees further to the west; but no instance perhaps can be cited which shows more strikingly the difference between a continental and an insular fauna, since, making every allowance for the ravages of cultivation by civilized man, the contrary is the case, and possibly no area of land so highly favoured by nature is so poorly furnished with the higher forms of animal life. Here, as over so large a portion of the Australian Region, we find Birds constituting the supreme class—the scarcity of Mammals being accounted for in some measure as a normal effect of insularity.

Glancing at the entire chain, we may first set aside the Bahamas, a succession of emerged coral-reefs founded on, and to the south and east surrounded by shoals or banks, broken only here and there by deeper channels; and then by drawing a line to the south of the Islands of St Croix

<sup>1</sup> See preceding footnote.

and St Bartholomew, we find that this line divides the chain into two groups of distinct character—that lying to the southward and eastward, almost identical with the "Windward Islands" of some geographers,<sup>1</sup> which, excepting Antigua and Barbadoes, are almost entirely volcanic, while no direct trace of recent volcanic action is known in the group lying to the northward and westward. These three divisions, however natural in appearance, can hardly be affirmed to form as many zoological provinces, owing to the absolute dearth of information respecting many of them, and the insufficient amount which has been received of the remainder. Taking the whole of the Antillean Subregion, the Bahamas, Cuba, Jamaica, St Choix, St Thomas, Sombrero, St Bartholomew, Guadeloupe, Dominica, Martinique, and St Lucia are the only islands of the ornithology of which we have anything more than what may be called a casual account; and hence, though valuable observations respecting some of the rest have been placed on record by travelling naturalists, any attempt to separate the Subregion into proper provinces would necessarily be of the crudest kind, and here cannot be made, though doubtless such provinces will eventually be defined with precision.

Still enough is known of the Birds of this Subregion to enable us to draw some conclusions, though certain of them seem especially likely to be overset by further investigation. It is inhabited by some 41 families, 1 of which (*Todidae*) is not found elsewhere, 2 more (*Corvidae* and *Cotingidae*) are confined to the Neotropical Region, 8 (*Mniotiltidae*, *Vireonidae*, *Tanagridae*, *Icteridae*, *Tyrannidae*, *Trochilidae*, *Cathartidae*, and *Aramidae*) are common to that and the Nearctic Region, but are peculiar to the New World, and 30 are of much more general distribution, but 2 of these (*Trogonidae* and *Fregatidae*) are not found in the Nearctic Region, and, as the above numbers show, there is no family common to that Region and the Antillean Subregion without also occurring in other parts of the Neotropical Region. On the whole, therefore, the affinity of the Subregion to the Neotropical rather than to the Nearctic Region is fully made out. About 140 genera are found in the Antilles, of which 30 are peculiar to it, being a considerably larger proportion than is elsewhere found in the Neotropical Region. Of these 30 genera, which are all Land-birds, 4 belong to *Turdidae*, 1 to each of *Mniotiltidae*, *Vireonidae*, *Ampelidae*, and *Corvidae*, 2 to *Tanagridae* and *Emberizidae* respectively, 1 to each of *Icteridae* and *Tyrannidae*, 5 to *Trochilidae*, 1 to *Caprimulgidae*, 2 to *Picidae*, 1 to *Todidae*, 2 to *Trogonidae*, *Oculidae*, and *Strigidae* respectively, and 1 to *Columbidae*.<sup>2</sup> Besides these, 21 more, which it is perhaps unnecessary to particularise, do not exceed the limits of the Neotropical region, while 5 others, belonging respectively to the families *Cypselidae*, *Fregatidae*, *Anatidae*, *Columbidae*, and *Rallidae*, occur both here and elsewhere in that Region without reaching the Nearctic except as stragglers. *Perisoreoidea*, belonging to the family *Mniotiltidae*, is the only genus common to the Nearctic Region and the Antillean Subregion without occurring elsewhere in the Neotropical Region, all the remaining Antillean genera inhabiting both North and South America. The distribution of some of

the peculiar genera merits a little attention, for 19 out of the 30 are confined to a single island, or nearly-connected group of islands. Thus, Cuba has 6 believed to be restricted to its soil; Jamaica, 7; Hispaniola, 2; and the so-called "Windward Islands," probably 4; while none are known to be absolutely limited to the Bahamas, to Porto Rico, or the Virgin Islands. It is possible, indeed, that Hispaniola and Porto Rico, if as well explored as Cuba and Jamaica have been, might tell a very different story.

Pursuing the subject further, and entering, so far as space will allow, upon a consideration of details, we find that there are of Land-birds about 200 resident species, and nearly 90 which are not resident, but migratory. These last belong to about 55 genera, of which some 40 have no resident insular representatives, while those migrants pertaining to genera which possess permanent residents are nearly all as much Neotropical as Nearctic in character. Most of these, so far as is known, visit Cuba only, where over 80 are recorded as occurring, while but 30 reach Jamaica. The number, however, in the island last named, and in others, would most likely be not inconsiderably increased did competent observers but exist, though the fact that a well-known species like the Humming-bird of eastern North America (*Trochilus colubria*) does not seek its winter-abode in any of the islands except the Bahamas and Cuba, tends to lessen the force of such a supposition, and points to our actual knowledge being not very far wrong. Among the more interesting of peculiar forms is one genus of *Turdidae* (*Mimocichla*), which is represented by 4 distinct species, found in the Bahamas, Cuba, Jamaica, and Hispaniola respectively. Another genus of the same family (*Margaropus*) has a species ranging from Hispaniola to the Virgin Islands, and a second species inhabiting Martinique and St Lucia only, these two islands possessing at the same time a third and peculiar genus (*Rhamphocinclus*), containing but a single species, common to both, while they also have another genus (*Cincoerthia*), a distinct species of which inhabits either island, though a third species of the same is found in Guadeloupe and Nevia. The genus *Certhiola*, belonging to the *Corvidae*, is remarkable in that it occurs in nearly every island except Cuba; but what seems to be still more extraordinary is that the species found in the Bahamas (*C. bahamensis*), and there alone in the whole Subregion, also occurs in Cozumal, an island off the coast of Yucatan, though Cuba intervenes. The distribution of *Spindalis*, one of the *Tanagridae*, resembles that of *Mimocichla*, above noticed, only that here Porto Rico also has its distinct representative species. Of the peculiar genera of Humming-birds, *Eulampis* has 2 species—one ranging from St Lucia to Nevia, but the second extending northward to St Thomas. *Aithya*, a very remarkable form, is restricted to Jamaica, while *Mellisuga* is common to that island and Hispaniola—each of these genera consisting of but one species only, and the last is the smallest known bird. *Orthorhynchus* seems to have 3 species, one extending from St Thomas to Dominica, a second (perhaps barely separable) common to Martinique and St Lucia, and a third to St Vincent and Barbadoes; and, finally, *Sporadinus* has one species in Cuba and at least one of the Bahamas, a second species in Hispaniola, and a third in Porto Rico. Of genera of Humming-birds, which are not confined to the Antilles, *Lampornis*, a widely-ranging genus, has two species peculiar to Jamaica and Porto Rico respectively; while a third extends from Hispaniola to St Thomas. *Calypte*, which has two species in Mexico, has a third peculiar to Cuba, while *Doricha* is represented in two of the Bahamas (New Providence and Inagua) by as many distinct species; the other three described species of the form inhabiting Central America, and none, so far as known, occurring in

<sup>1</sup> In the language of others, the "Windward Islands" begin with Martinique and so continue to Trinidad, while the remainder of the Lesser Antilles, lying eastward of Porto Rico, are called the "Leeward Islands." Other authorities name all the smaller islands so far as St Thomas "Windward Islands," and those further westward the "Leeward." Creoles appear to apply these terms relatively to their own habitation, just as the dweller on the bank of a river speaks of "up stream" and "down stream" with sole reference to the position he occupies on the margin; and it might be wished, though that were vain, that the use of terms so little definite should be abandoned.

<sup>2</sup> This genus (*Sternonax*) has been said, however, to occur in the Florida Keys, but the statement seems doubtful.

Cuba; and thus we have afforded us another case of interrupted generic distribution somewhat like though not quite so extraordinary as that of *Certhiola* already noticed. In all, about 17 species of *Trochilidae* are found in the Antilles, of which only one, and that of exceptionally developed migratory habits, occurs elsewhere. The peculiar family *Todidae* has been already mentioned; and it is only necessary here to remark that the single genus *Todus* which it contains seems to have 5 species, one limited to each of the large islands, Cuba, Jamaica, Hispaniola, and Porto Rico, the fifth being from an unknown locality.<sup>1</sup> Much the same has to be said of *Sayornis*, a genus of *Ouculidae*, which is represented by a distinct species in each of these four islands, while another genus of the same family, *Hytornis*, with one species, is peculiar to Jamaica. The *Trogonidae* have two genera, *Prionotoles* and *Temnotrogon*, each with a single species, the former peculiar to Cuba, and the latter, which exhibits a remarkable affinity to the African genus *Hapaloderma*, to Hispaniola. *Pseudoscops*, a genus of *Strigidae*, is peculiar to Jamaica, but *Gymnoscops*, belonging to the same family, has one species limited to Cuba, while a second extends from Porto Rico to some of the Virgin Islands. Cuba also, besides a widely-ranging species of Kestrel (*Tinnunculus*), has a second species which is peculiar to the island. Jamaica, on the other hand, seems to have no Kestrel at all.

Any speculations as to the former history of the Antilles derived from our imperfect knowledge of their existing ornithology would be vain. It is enough to perceive, as the preceding facts will show, that there must here have been no ordinary amount of upheaval and subsidence, of turning land into water and water into land, to account for the present distribution of their avifauna. More wonderful than any evidence given by the Birds, is that which is afforded by other Classes. It is asserted that *Solenodon*, an Antillean genus of Insectivorous Mammals, has its nearest ally in a Malagasy form; and a splendid Butterfly, found only in Jamaica (*Uranis sloansii*), belongs to a genus of which while two other species are known from Central and South America respectively, the only other genus resembling it is one that inhabits Madagascar.

III. THE NEARCTIC REGION comprises all that is left of the American continent, after the Neotropical Region has been taken off, and certain outlying groups of islands, such as the Aleutian chain, with its immediate dependencies, and the Bermudas—none of them, however, being of any great importance,—as well as the circumpolar lands lying westward of long. 60° W., and Greenland. The confines of these two Regions, as before stated (page 748), are as yet but vaguely traced. All that is known for certain is that the more northern runs considerably southward along the highlands of Central America, and that its influence, as determined by the presence of resident genera of northern extraction, is perceptibly felt on the summits or slopes of the mountains, at least so far southward as lat. 20° N. In the lowlands the boundary lies much further towards the north, and, perhaps, in general terms, may be placed somewhere about lat. 25° N., while both in lowlands and highlands, as above explained, the northern influence varies with the seasons of the year, being greatest in winter, when the migratory birds, which breed in the Nearctic Region, have turned their flight southward, and least in summer, when they have retired to their northern homes. If the avifauna of the Neotropical Region could, in a wide sense, be truly termed homogeneous, much more is this the state of the case with the Nearctic. Of the 63 families<sup>2</sup> of Birds, which is the highest number

that it seems possible to count for this region, only 1, *Chamaeidae*, is peculiar, and the validity of the grounds on which this has been established as such may be open to question; 44 of them are also Palearctic; and the remaining 18 are common to the Neotropical Region, of which last number at least 4 (*Trogonidae*, *Plotidae*, *Fregatidae*, and *Phaetonidae*) have a much more extended range. Thus there are 14 peculiarly American families left. These are *Mniotiltidae*, *Corcebidae*, *Tanagridae*, *Vireonidae*, *Icteridae*, *Tyrannidae*, *Trochilidae*, *Momotidae*, *Aridae*, *Cathartidae*, *Cracidae*, *Melagridae*, *Tantalidae*, and *Aramidae*. But the propriety of here admitting *Trogonidae* (mentioned above) and *Momotidae* is very doubtful; for, though included by Dr Coues, they are omitted by Professor Baird, from his *North American Birds*, the most recent work on the subject. The claim of *Corcebidae* to be considered Nearctic is also slender, resting on the fact that a small colony of the Sugar-bird which inhabits the Bahamas (*Certhiola bahamensis*) has established itself on one of the Florida Keys. The *Aridae* are represented in the Region by a single species only—the long-known Carolina Parakeet (*Conurus carolinensis*); and the *Tanagridae*, a family containing upwards of forty genera, have but one genus (*Pyrranga*), exemplified by four or five species, out of about a dozen, which occur within its limits.

On the other hand, the peculiarly American families best represented in the Nearctic Region seem to be four in number,—*Mniotiltidae*, by 13 genera and about 50 species, *Vireonidae* by 1 genus and 14 species, *Icteridae* by 8 genera and 21 species, and *Tyrannidae* by 8 genera and 26 species. The first of these, however, can alone be regarded as eminently characteristic of the Region, since that affords a home to all but 3 of the genera, but at the same time, only about one-half of the described species occur there. None of the rest can compare with it in this respect, *Vireonidae* having 5 genera and 50 species, *Icteridae* 24 genera and 105 species, and *Tyrannidae* 71 genera and 324 species in the Neotropical Region.

Coming now to the genera of Nearctic birds, we may put the number perhaps at 330, of which 24 seem to be peculiar to the Region; 2 of them belong to *Turdidae*, 1 to *Chamaeidae*, *Paridae*, *Troglodytidae*, and *Motacillidae* respectively, 5 to *Emberizidae*, 2 to *Corvidae*, 1 to each of *Picidae*, *Falconidae*, and *Columbidae*, 5 to *Tetraonidae*, and 1 to *Scolopacidae*, *Anatidae*, and *Laridae* respectively. But it is perhaps worth remarking that the families *Emberizidae* and *Tetraonidae*, here most abundantly represented by genera, are still more abundantly represented in like manner elsewhere. In the Neotropical Region we have some 30 and in the Old World some 15 genera of the former, which are not found in the Nearctic Region; and the Old World has some 30 genera of the latter which are not found in the New. On the other hand it must be admitted that if we subdivide the American *Tetraonidae* into sections or sub-families, we find that while one of those sections, the *Odonophorinae*, is peculiar to America, the balance as regards the other, *Tetraoninae*, is clearly in favour of its greater development in North America, where we have 3 genera absolutely peculiar, as well as 3 others which are also found in the Palearctic Region. With this Region, indeed, the Nearctic has about 128 genera in common, having 178 which are also Neotropical. Returning to these last presently, it may be advisable here to give some particulars of those which are common to both sides of the North Atlantic. 1 belongs to each of the families *Turdidae* and *Cinclididae*; 3 to *Sylviidae*, 2 to *Paridae*, 1 to *Sittidae*, *Certhiidae*, *Troglodytidae*, and *Alaudidae* respectively, 2 to each of *Motacillidae* are not regarded as good families by the writer. They are all common also to the Palearctic Region.

<sup>1</sup> A bird of this group was one of those asserted by Ledru to have formerly occurred in St Thomas (page 784).

<sup>2</sup> Three of these (*Hemitelesidae*, *Stenocercidae*, and *Phalaropidae*)

*alida* and *Hirundinida*, 1 to *Ampelida* and *Laniida* respectively, 7 to *Fringillida*, 2 to *Emberisida*, 3 to *Corida*, 1 to each of *Cypselida* and *Alcedonida*, 3 to *Picida*, 9 to *Syringida*, 10 to *Falconida*, 1 to *Columbida*, 3 to *Tetraonida* and *Charadriida* respectively, 2 to each of *Hamptopodida*, *Recurvirostrida*, and *Phalaropodida*, 7 to *Scolopacida*, 1 to *Ibidida* and *Plataleida* respectively, 4 to *Ardeida*, 1 to *Gruidae*, 5 to *Rallida*, 1 to *Phanicopterida*, 18 to *Anatida*, 1 to each of *Suidae*, *Pelecanida*, and *Phalacrocoracida*, 6 to *Larida*, 3 to *Procellariida*, 1 to each of *Colymbida* and *Podicipedida*, and 10 to *Alcida*. Thus it will be seen that no less than 87, or more than one-sixth of the whole 330 genera, are purely Land-birds,—a very large proportion.

The genera which occur both in the Nearctic and Neotropical Regions, without appearing in the Palearctic, must be divided into two categories in order to arrive at a just estimate of the relations of the avifaunas of the first two. These categories consist of those genera which, being only winter visitants to the southern Region, do not breed there, and those which may fairly be called common to both. The latter need perhaps no further attention, after what has been previously said of the Central-American Subregion (p. 748), but the former require some notice. Of those in this category 1 genus belongs to each of the families *Sylviida* and *Troglodytida*, 8 to *Mniotiltida*, 6 to *Emberisida*, 1 to *Icteriida*, *Trochilida*, *Picida*, and *Columbida* respectively, 6 to *Scolopacida*, and 1 to *Phalaropodida*—27 in all. These must, of course, be considered characteristic of the Nearctic Region, and might, indeed, be not inappropriately added to the 24 genera which are, as already said, peculiar thereto; but even if this be done, we find the number of peculiar and characteristic genera (taken together) of the Nearctic Region to be only 51—a smaller number than that of the genera of Land-birds alone (57) which are common to the Palearctic, and considerably less than half the number of all genera which are found on both sides of the Atlantic (128), while the remaining genera which are strictly common to the Neotropical (151) is much larger again. Thus, regarded simply from an ornithologist's point of view, what we call the Nearctic "Region" seems to have no right to be considered one of the primary Regions of the earth's surface, and to be of less importance than some of the Subregions of the Neotropical Region, as may be shewn more plainly by the following table:—

	Whole No. of Genera of Birds.	Peculiar Genera of Birds.
Patagonian Subregion.....	290	46
Brazilian .....	396	43
Amazonian .....	373	27
Subandean .....	469	72
Central-American.....	464	46
Antillean .....	140	30
Nearctic Region.....	330	24

It is not, however, intended here to question the validity of the Nearctic Region in a zoogeographical sense. If that position could be successfully disputed, it must be done on more than ornithological grounds, and a consideration of them would be out of place in this article. It is enough to mention that though the Mammals would possibly lead to much the same conclusion as the Birds do, yet the lower Classes of Vertebrates—Reptiles, Amphibians, and Fishes—would most likely have a contrary tendency, while the present writer is quite unable to guess at the result which would be afforded by the Invertebrates. Now, as in map-

<sup>1</sup> Of many American Birds, especially Water-birds, which from time to time occur as stragglers in Europe, no account has here been taken, and, of course, they will not be reckoned in our computation of Palearctic genera.

ping out the world into zoological Regions all animals have to be regarded, he has no wish to disturb the scheme which has been so generally approved, but contents himself with pointing out that the case for its adoption is not in this particular instance strengthened by the evidence given by the Class *Aves*.

A great majority of the Nearctic families and genera of Birds appear to be generally distributed throughout all the "Subregions," or perhaps it would be better to call them "provinces," into which ingenuitly can separate the Region. And on this account, as well as from what has been urged in the preceding paragraph, it seems unnecessary to treat of each "Subregion" or "provinces" so fully as has hitherto been done in the present article. Indeed such districts are not easily defined, and their definition rests rather on differences of species than of higher groups, as we have found to be the case in discussing the several component parts of the other Regions we have considered. Professor Baird, in a masterly treatise on this and another subject,<sup>2</sup> would first divide that portion of North America which constitutes the Nearctic Region into two principal sections, the Eastern extending from the Atlantic sea-board westward across the Alleghany Mountains and over the valley of the Mississippi and its fertile prairies to about long. 100° W., where the sterile plain begin. The western boundary of this division, however, is not sharply defined, nor does it coincide with any meridian line, but lies somewhat obliquely and interdigitates with the eastern confines of the next division by extending westward along the river-bottoms. Marching with this irregular frontier we have the second, or Western, great division reaching thence to the shores of the Pacific, and though the character of its avifauna is much the same through and beyond the Rocky Mountains to the eastern slope of the Sierra Nevada and Cascade Mountains of California and Oregon, it changes somewhat on their western slope and thence to the sea, exhibiting modifications which may warrant further separation into a truly Western and a Central subdivision—thus making in all three provinces for the whole of the more southern part of the Nearctic Region, while each of them shews, as might be expected, indications of additional change, subject in great measure to the degree of latitude under which any particular locality in them may lie.

Having thus pointed out the three provinces into which this portion of the Region can be separated, it may be well to cull from Professor Baird's investigations of the subject some further details. The boundary of the Eastern province, which, taking up an old name, we may perhaps term the "Alleghanian"—from the principal mountain range within its limits,—starts from the Gulf of Mexico, near the eastern border of Texas, perhaps between the rivers Brazos and Sabine, and following the course of the former to the great American Desert, in about long. 100° W., runs northward, forced sometimes more or less westward, especially along the Platte, and sometimes eastward. It crosses the Platte between Fort Kearney and Laramie, and apparently intersects the Missouri about Fort Lookout. Reaching the southern frontier of the Dominion of Canada, it rapidly inclines to the westward, and including the valleys of the Saskatchewan and the Athabasca, it crosses the Rocky Mountains, and, cutting the river Yukon below the junction of the Pelly and the Porcupine, loses itself in the wilds which border the Arctic Ocean. Since the Middle province—on which as yet no more precise name has been bestowed—lies for the most part between the Alleghanian and the Western or "Californian," as it has been entitled, the boundaries of this last had best, so far

<sup>2</sup> "The Distribution and Migrations of North American Birds," *American Journal of Science and Arts*, ser. 2, vol. xli. pp. 78-90, 184-192, 337-347 (January, March, and May, 1866).

as is possible, be given. Its extent both southward and northward is somewhat indefinite. The avifauna of Cape San Lucas, at the extremity of the peninsula of Old or Lower California, is said to be thoroughly that of the "Middle" province, but whether the whole of that promontory is to be reckoned as belonging thereto, or only its eastern border, is not known. It appears, however, that some of the most characteristic forms of the Middle province find their way to the Pacific coast through a break in the mountains opposite to San Diego, and it is to be remarked that the difference between the species of birds found at Cape San Lucas (of which about a score are absolutely peculiar) and of Mazatlan, though separated only by the breadth of the Gulf of California, is very great. Northward the boundary of the Californian province probably runs along the Sierra Nevada and the Cascade Mountains before named, so that its extent is contracted to a mere strip along the coast, while still further to the north, in British Columbia, no precise details of its limits have as yet reached this country. But it would seem that in Alaska, as will presently be stated at greater length, an avifauna presenting many very different characters from any found elsewhere in America is reached, for here we encounter a number of genuine Palearctic forms.

But these are not all the zoological provinces into which this part of North America can be separated. A fourth, of especially Arctic type, occupies the northern portion of the continent, and gradually melts away into the rest, extending far to the southward along the highest ranges, even to Fort Burgwyn, in lat. 37° N., if not beyond. This province may be called the "Canadian," from the ancient colony of that name constituting so large a portion of it, but its limits must be confessed to be indefinite in a high degree. The eastern half, at least, of the British possessions in North America are herein included, and the province may be deemed to extend across Davis's Strait to Greenland.

In noticing these provinces, the results of Professor Baird's researches have been, with little deviation, mainly adopted, but his enquiries have been largely supplemented by the more recent investigations of Mr J. A. Allen, who has admirably carried out the further subdivision of the Eastern, or, as it has been termed, the Alleghanian province, together with part of what has just been denominated the Canadian. Regarding the whole eastern half of the continent as one province, he recognises in it the existence of seven distinct ornithological faunas, namely, the Floridan, the Louisianian, the Carolinian, the Alleghanian, the Canadian, the Hudsonian, and the American-Arctic, comparing them also with the distribution therein of Mammals and Reptiles.<sup>1</sup> To describe more fully the boundaries of these faunas would be to enter on matters too special for our present purpose, and it must suffice to direct attention to this essay of Mr Allen's, which, like others of his,<sup>2</sup> though their titles may seem to indicate for them but a limited scope, has, in truth, a very general bearing.

The provinces above named (and naturally the districts which they comprise) appear to be characterized rather by the presence or absence of certain species of widely-spread genera than by the presence or absence of the genera themselves, and much less of families, but it seems expedient to notice some of the chief exceptions to general distribution in the latter of these groups. First we have the peculiar family of *Chamæidæ*, restricted so far as is known to the coast-district of California, where it is represented by a single genus and a single species; and then

among families of greater range, the *Certhiidae*, already introduced to us as a Neotropical group, but in the Nearctic Region existing only in the case of the colony of a species of *Certhiola* before noticed; the *Aridae*, nowadays almost limited to Western Louisiana, Arkansas, and Florida, but formerly known along the whole valley of the Mississippi to the verge of the Great Lakes, and even occasionally penetrating to Pennsylvania and the State of New York; the *Cathartidae*, of which one genus (*Pseudogryphus*), having for its sole species one of the largest birds of flight, the Californian Vulture (*P. californianus*), is confined to the Pacific coast from a little north of the Columbia River to the Colorado, extending eastward to the Sierra Nevada, while of another genus (*Cathartes*) one species ranges from the Strait of Magellan to the Saskatchewan, but a second hardly strays further northward than North Carolina, and does not occur on the Pacific coast of the United States; the Turkeys (*Meleagridæ*), found only to the eastward of the Rocky Mountains, and now extinct in most of the settled districts of Pennsylvania, New England, and Canada; the Wood-Ibises (*Tantalidæ*), belonging to the southern country from the Colorado eastward, and so far to the north as the State of Ohio and the Carolinas; the Spoonbills (*Plataleidæ*), with apparently much the same range as the last, but more limited towards the north, being of only accidental occurrence on the Lower Mississippi and in the Carolinas; the Courlans (*Aramidæ*), frequenting in this region only the shores of the Gulf of Mexico and the coast of Florida; the Flamingoes (*Phasianopteridæ*), with haunts nearly as much confined, though occasionally reaching South Carolina; the Pelicans (*Pelecanidæ*), having one species abundant in the Western and only by chance occurring in the Middle and Eastern states, while a second is of strictly marine habit, and is found on the coast of California, and in the Gulf of Mexico and the shores of Florida. The single representative of the Darters (*Flotidæ*) in summer reaches North Carolina and Illinois, but that of the Frigate-birds (*Fregatidæ*) is confined to the shores of the great Gulf, while that of the Tropic-birds (*Phaetonidæ*) not only haunts the same waters but also finds a nursery in the Bermudas; the species of Divers (*Colymbidæ*) breed only in the north—Halifax, in lat. 45° N., being perhaps their most southern limit of reproduction; while, finally, the Auks (*Alcidæ*), Sea-birds of northern range, exhibit a most remarkable development of genera, species, and individuals on the rocky cliffs and islets which rise from the North Pacific.

Reference has already been made to the peculiarity of the avifauna of Alaska—Russian America, as it was formerly called,—and its character needs brief notice. The list of Birds observed in this territory, as given by Messrs Dall and Bannister,<sup>3</sup> seems after due revision to number 210 species. Of these 96 are Land-birds, belonging to 63 genera, whereof 20 at the outside are peculiarly American, while of the remaining 43, which are common to the Nearctic and Palearctic Regions, 3 are found nowhere else in the New World but in Alaska, and their occurrence there does not preclude us from setting them down as being emphatically Palearctic forms. Two of them are actually represented by species common throughout the greater part of Asia and Europe, as is the case with *Budytes flavus*, a Yellow Wagtail, and *Phylloscopus borealis*, a Willow-Wren, while the third is a peculiar species of Bullfinch, *Pyrrhuloxia castaneus*. Of the whole 96 species of Land-birds, 23, or nearly one-fourth, are common to the two Regions. The Water-birds, amounting to 115 species, are referable to 63 genera, of which only 4 (all belonging to *Scolopacidæ*) are

<sup>1</sup> *Bulletin of the Museum of Comparative Zoology at Harvard College*, vol. ii. pp. 387-407.

<sup>2</sup> *Memoirs of the Boston Society of Natural History*, vol. i. pp. 448-526, and *Bulletin of the Museum of Comparative Zoology*, vol. iii. pp. 118-183.

<sup>3</sup> *Transactions of the Chicago Academy of Sciences*, vol. i. pp. 267-310.

peculiarly Nearctic, though of the species 58 are truly American against 52 common to both Regions, one of these last, however, not having been found elsewhere in the New World, while the home of 5 seems doubtful. These numbers will show the great influence of Palaearctic forms on Alaska, and it only remains to be said that some of the ordinary summer-migrants thither would seem to arrive there from Asia, as the Wagtail and Willow-Wren just mentioned, to which should possibly be added the Wheatear (*Saricola ananthe*), for though that species is known as a regular annual visitant to Greenland and Labrador (where it breeds), and almost annually appears as a straggler on the eastern coast of the United States, the flocks which throng the stony hill-tops of Alaska in spring are not likely to have performed a north-west passage from Europe, and indeed it is stated that specimens from Norton Sound differ considerably in dimensions from those obtained in Greenland. All these Birds are unseen in British Columbia, and as all are migratory, the inference that they make some part of Asia their winter-quarters is almost irresistible.

After all, perhaps there is nothing very surprising in this, when we consider the narrowness of the channel<sup>1</sup> by which in these longitudes the New World is divided from the Old, and it would seem that it is almost within the confines of the Arctic circle that, apart from circumpolar species, the connection of the faunas of the two continents is closest. At any rate, the Aleutian Islands, though they look like stepping-stones from the one to the other, do not appear to be used as a route of communication; for Mr Dall calls especial attention to the fact that no intrusion of Asiatic forms occurs towards the western end of the chain, while observing that its avifauna beyond Oonalaaka is reinforced by several Arctic species not possessed by more eastern islands.<sup>2</sup>

Northward of the Aleutians lies a little volcanic group known as the Frybilov Islands, whose coasts are frequently encumbered by ice, and there only 40 species of Birds have as yet been found, while those which breed are about 12 in number, and among them a Sandpiper (*Tringa pilocnemis*), apparently peculiar to St Paul's Island, the largest of the group. Only one of the characteristically Palaearctic forms, and this also a Water-bird (*Limosa uropygialis*), which appear but in Alaska, seems there to occur—a fact which points yet again to the more northern connection of the two continents by way of Cape Prince-of-Wales and the East Cape (Vostochni) of Asia.

We have next to turn to another group of islands, situated in a different ocean, and in formation very unlike that last considered. These are the Bermudas, a cluster of low coral-reefs rising from the Atlantic, about 600 miles from Cape Hatteras, the nearest point on the eastern coast of North America. They possess but few Land-birds, and not a single peculiar species, yet they play by no means an unimportant part as a resting-station to the flocks of migrants as they retreat southward from their northern homes in Labrador and Greenland, and, though less often, on their northward journey in spring. Only about 6 Land-birds are resident, and about as many Water-birds are known to breed there; but the number of stragglers is large, and includes two or three of undoubtedly European extraction.

Greenland is the last portion of the Nearctic Region to which we shall especially invite attention, and there though the character of the avifauna is certainly that of the New World, yet that of the Old is very influential. Out of the 45 genera to which the feathered inhabitants of Greenland

belong, none are peculiar to the Palaearctic Region, while 2—*Zonotrichia*, one of the *Emberizidae*, and *Rhodostethia*, one of the *Laridae*—are peculiar to the Nearctic. If we take the species, we find that of the 63 inhabitants, those peculiar to the New World amount to 11, while those not elsewhere dwelling out of the Old are only 5. But, on the other hand, the Sea-Eagle (*Haliaeetus*), the Ringed Plover (*Actitis*), and the Snipe (*Scolopax*) which breed in Greenland are those of Europe instead of their American congeners; and the Wheatear (*Saricola*), the Sanderling (*Calidris*), the Knot (*Tringa canutus*), and the Barnacle-Goose (*Bernicla leucopsis*) would appear to cross the Atlantic from the east, while 43 out of the 63 inhabitant species are every bit as much Palaearctic as Nearctic; and 2 more, the Ptarmigan (*Lagopus rupestris*) and Barrow's Duck (*Clangula islandica*) breed abundantly in Iceland. Following the western coast-line (for of the eastern we know little) to the Arctic circle,<sup>3</sup> we find the proportion of forms which are common to the Palaearctic Region increase, until in lat. 75° N. or thereabouts, there are (so far as our means of information will allow us to judge) no species of Birds which have not been known to occur, and only about 5 which have not been known to breed, in the Old World.

It has been already stated that 128 out of the 330 Nearctic genera, or more than one-third, are common also to the Palaearctic Region. This will serve to show the great similarity of the two; and if we investigate the species, the similarity is still to a great extent borne out. Taking the number of Nearctic species at 700 (which is perhaps an exaggeration), and that of the Palaearctic at 850 (which is certainly under the mark), we find that, exclusive of stragglers, there are about 100 common to the two Regions. Nearly 20 more are Palaearctic but occasionally occur in America, and about 50 are Nearctic which from time to time stray to Europe or Asia.<sup>4</sup> But this is not the only ground of the resemblance. Of many genera the species found in the New World are represented in the Old by species which often no one but an expert can distinguish. Of such representative or parallel species, somewhere about 80 might be enumerated; and thus the relation of the two regions may be concisely stated:—

Species inhabiting the Nearctic Region....	(say) 700.	Species inhabiting the Palaearctic Region..	(say) 850.
Species of one Region represented by closely allied forms in the other.....	(say) 80.	Species identical in both Regions.....	(say) 100.
Palaearctic species occasionally found in the Nearctic Region	(say) 20.	Nearctic species occasionally found in the Palaearctic Region..	(say) 50.

IV. THE PALAARCTIC REGION begins with the Atlantic Islands (the Azores, Canaries, and Madeiras) and includes that portion of North-west Africa which was formerly known as the Barbary States, the whole of Europe and its islands—from Iceland and Spitzbergen to those of the Mediterranean—Asia Minor, Palestine, Persia, Afghanistan, and all the rest of the Asiatic continent lying to the northward of the Himalaya Mountains and of a line drawn as though it was a prolongation of that range to the east-

<sup>1</sup> People are apt to forget that Cape Farewell, the most southerly point of Greenland, lies in the latitude which cuts the Shetlands and passes far to the south of Iceland; and a large portion of the country though undoubtedly exposed in the highest degree to the rigours of an Arctic climate, is situated outside the Arctic circle.

<sup>2</sup> Professor Baird, in the essay before cited, has reasonably accounted for this disproportionate reciprocity between Europe and America; but perhaps something more than he has allowed must be set down to the comparative want of records in the new country, where observers and amateur collectors have until lately been scarce. This want is, however, being speedily supplied by the numerous students of outdoor ornithology, who are everywhere springing up throughout the United States.

<sup>3</sup> Behring's Strait is said also to be very shallow, which fact is suggestive as to a still greater interchange of animal life in past ages.

<sup>4</sup> Proceedings of the Californian Academy of Sciences, 14th March 1874.

ward somewhere between lat. 30° and 35° N. till it meets the Pacific Ocean; besides Japan and the Kurile Islands. The propriety of comprehending this enormous tract in one Zoological Region was first shown by Mr Sclater, in the paper to which reference has before been made,<sup>1</sup> and as regards the distribution of most classes of animals there have been few to doubt that it is an extremely natural one. Not indeed altogether so homogeneous as the Nearctic Region, it presents however even at its extreme points no very striking difference between the bulk of its Birds. Though Japan is far removed from Western Europe, and though a few generic forms and still fewer families inhabit the one without also frequenting the other, yet there is a most astonishing similarity in a large portion of their respective Birds. In some cases the closest examination has failed to detect any distinction that may be called specific between the members of their avifauna; but in most it is possible to discover just sufficient difference to warrant a separation of the subjects. Nevertheless it is clear that in Japan we have as it were a repetition of some of our most familiar species—the Redbreast and the Hedge-Sparrow for example—slightly modified in plumage or otherwise so as to furnish instances of the most accurate representation.

The limits of the western portion of the Region are definite enough, for except in its African province it is girt by the sea, but even there we find a boundary hardly inferior to a coast-line in the precision with which it may be recognized and in the influence it exerts. This is the Great Desert, commonly known as the Sahara, which, though yearly crossed by innumerable multitudes of many of the more migratory species, just as the sea itself is traversed by them, acts as a complete barrier to the less migratory and to the residents, cutting off the denizens of Morocco, Algeria, and Tunis from the rest of the continent to which they are geographically attached. Further to the eastward, however, the limits of the Region are if in any way marked at least but little known, though indications are not wanting to show that the avifauna of Tripoli is rather Ethiopian than Palearctic in its character. When we reach Egypt we have a state of things which may be compared to that debatable land in Central America wherein the Neotropical and Nearctic avifaunas meet but hardly mingle. During winter the bird-population of the Nile-valley is formed almost exclusively of the hordes of European migrants of nearly all Orders and families which there seek refuge. When spring returns these begin to troop across the Mediterranean, and their place is taken by the indigenous Birds of Egypt which had been either reduced to comparative insignificance by, or actually thrust out before, the northern invaders. The seaboard of Palestine, and even its interior, until the western limits of the Jordan-basin are touched, are on the contrary almost purely Palearctic, but the depressed valley of the Ghor, part of which is sunk about 1300 feet below the level of the Mediterranean, seems to be an outlier of the Ethiopian Region, and though the scanty avifauna of the Mountains of Moab may possess a northern phase, the desert, with its characteristic, and in the main Ethiopian, forms of animal-life almost immediately succeeds, and it is not until the fertile plains of Mesopotamia are approached or attained that we can feel assured we have again entered the Palearctic area, which may be considered to reach the head of the Persian Gulf. Coasting this inlet on its eastern side we have a fauna the character of which it is as yet impossible to declare, and this difficulty becomes greater still when we emerge into the Indian Ocean. It seems most probable

that Beloochistan belongs to the Palearctic Region, but if not then the line of demarcation must run inland and so continue between that land and Afghanistan till, ascending the right bank of the valley of the Indus, it turns the shoulder of the Great Snowy Range and thence proceeds in the direction already traced parallel to the southern frontier of Thibet, and across the intervening portion of the Chinese Empire, once more to the ocean. Arrived here the remaining limits of the Region are as well marked by the coast-line as they were in Europe. They extend to Kamchatka, and rounding the furthest verge of Asia, within the Arctic Circle, they return by the north coast of Siberia till the confines of Europe are again reached.

To separate this vast area into subsidiary districts according to the zoological properties of each is perhaps a less easy task than is the same operation with regard to the Nearctic Region, and, as in that case, the mapping-out of the whole into Subregions is almost impossible except it be done arbitrarily. Nevertheless the attempt must be made, and, though in the Asiatic half considerable assistance is to be derived from a careful essay by Mr Elwes,<sup>2</sup> respecting the European moiety much doubt may be reasonably entertained.

The very fulness of the information which we possess as to the ornithology of some countries of Europe makes the scarcity of it in respect to others all the more conspicuous, and renders any really comprehensive view of the whole all the more difficult. Grounds are not wanting at first sight in favour of a longitudinal or approximately longitudinal division of this quarter of the globe, in which case the line of demarcation might be taken to run up the Adriatic Sea, and starting from the neighbourhood of Trieste, to cross the Carnic Alps, descend the valley of the Inn till it falls into the Danube, and thence follow the angular mountain frontier of Bohemia as far as the head-waters of the Niessa, along which it would proceed to their junction with the Oder, and so to the Baltic a little to the westward of Stettin. Thence it might be continued northward between Geland and Gotland up the Gulf of Bothnia to the confines of Sweden and Finland, where cutting the Scandinavian peninsula to the westward of the Lower Torneå and its affluent the Muonio it would strike the shores of the Arctic Ocean perhaps on the Lyngen Fjord. Though undoubtedly most species of Birds are common to both sides of this imaginary line, yet it would be found to divide the breeding-range of a few which are very characteristic of the east and west of Europe respectively. But on further consideration it would seem that though such a division as has just been suggested may be convenient if not natural for the countries lying north of the Mediterranean basin, those, such as the three principal peninsulas which project into the great inland sea, together with the portion of North Africa which was at one time known as Mauritania, form a group which have much in common, and collectively differ more from the countries lying further to the north than the two (Eastern and Western) divisions of Central and Northern Europe, just suggested, do from one another. Accordingly it seems best to adopt primarily a latitudinal division of the Western part of the Palearctic Region. This done we should have as our first Subregion all Europe north of the Pyrenees, the Alps, the Balkan, the Black Sea, and the Caucasus, and since it would thus comprehend by far the greater portion of this quarter of the globe, we may not inappropriately call it the "European" Subregion, further subdividing it if we think fit into a Western and an Eastern Province, according to the boundary above traced—the eastern boundary of the last being indeed very uncertain, though perhaps to

<sup>1</sup> *Journal of the Proceedings of the Linnean Society, Zoology*, vol. ii. pp. 134-138.

<sup>2</sup> *Proceedings of the Ecological Society*, 1873; p. 618.



be limited by the Ural Mountains and the River of the same name. Next we should have the Subregion to which we may most properly affix the name of "Mediterranean," comprehending the portion of North Africa already indicated, the Iberian and Italian peninsulas, as well as Turkey in Europe and the Peloponnesus, but we must extend it far to the eastward through Asia Minor and Persia until it touches the Indian Region. The lofty range of the Caucasus would divide it from the European Subregion between the Black Sea and the Caspian; beyond the latter, however, we cannot do more than guess that the desert of the Tekko Turcomans and the mountains of Cabool would form its northern boundary. Then stretching from the eastern shores of the Caspian in a wide belt, but how wide is a matter of the greatest uncertainty, comes the third Subregion, which we may call the "Mongolian"—marching with the Mediterranean Subregion till the Hindoo Koosh is reached, and thence coincident with the southern borders of the Region towards the Yellow Sea—possibly following the course of the Yangtze-kiang. To this Subregion also would belong the greater part if not the whole of Japan. Northward again we have the great "Siberian" Subregion, but materials for any attempt to shew whether its southern boundary is capable of being laid down are absolutely wanting. Even on the seaboard it is at present impossible to say whether it is in Manchuria that one Subregion passes into the other, or whether first the Stannoi and further inland the Altai Mountains mark their respective limits.

Having thus indicated the component parts of the whole area, it is time to say somewhat of its avifaunal characters. Like the Nearctic the Palearctic Region seems to produce but a single peculiar family of Birds—the *Panurida*, the type of which is the beautiful species known to Englishmen as the Bearded Titmouse (*Panurus biarmicus*)—and this is a family which has not been long or very generally recognized. Its members, however, are found stationed at intervals from the western to the eastern extremity, and every attempt to refer them to other groups of Birds has proved unsatisfactory—for the different genera (about the number of which there is much doubt) have often been widely scattered by systematists, one being placed at times with the Titmouse-family (*Parida*), at times with the Buntings (*Emberisida*), another relegated to the Finches (*Fringillida*), and a third or even more to the so-called "Babblers" (*Timeliida*). The entire number of Palearctic families, computing them as we have already done those of other Regions, is about 67, not counting 1 other (*Nectarinida*) of which a single species is peculiar to the valley of the Ghor, and that of the genera 323, about which there can be little doubt, or if any exist it may be that the number is understated. Of these as we have above mentioned 128 are common to the Nearctic Region. Species of 51 more seem to occur as true natives both in the Ethiopian and Indian Regions, of which 4 genera belong to *Sylviida*, 1 each to *Timeliida*, *Isida*, and *Oriolida*, 2 to *Muscicapida*, 1 to *Laniida*, 2 to *Motacillida*, 1 to *Dicaeida*, 2 to *Fringillida*, 1 to *Emberisida*, 3 to *Alaudida*, 1 to *Cuculida*, 2 to *Coraciida*, 1 to *Meropida*, *Upupida*, *Caprimulgida*, and *Cypselida* respectively, 4 to *Vulturida*, 6 to *Falconida*, 1 to each of *Strigida*, *Columbida*, and *Pterocleida*, 3 to *Tetraonida*, 1 to *Turnicida*, 2 to *Otidida* and *Charadriida*, and 1 to each of *Glareolida*, *Cursorida*, *Larida*, and *Anatida*. Besides these 18 appear to be common to the Ethiopian without being found in the Indian Region, and no fewer than 71 to the Indian without being found in the Ethiopian. Of the former 1 is referable to *Turdida*, 9 to *Sylviida*, 1 to each of *Timeliida*, *Muscicapida*, *Laniida*, and *Motacillida*, 3 to *Fringillida*, 1 to *Emberisida* and *Sturnida* respectively, 3 to *Alaudida*, and 1 to each of *Gruidida* and *Ciconiida*.

Of the latter, 2 genera belong to *Turdida*, 17 to *Sylviida*, 4 to *Timeliida*, 1 to each of *Troglodytida* and *Certhiida*, 3 to *Liotrichida*, 1 to *Parida* and *Isida* respectively, 4 to *Muscicapida*, 1 to each of *Motacillida* and *Hirundinida*, 3 to *Fringillida*, 4 to *Sturnida*, 3 to *Corvida*, 1 to *Pittida*, 2 to *Picida*, 1 to *Jynghida* and *Cuculida* respectively, 2 to *Alcedinida*, 1 to *Vulturida*, 3 to *Strigida*, 2 to each of *Columbida* and *Tetraonida*, 5 to *Phasianida*, 1 to *Otidida*, 3 to *Scolopacida*, and 1 to *Anatida*. To compare the Palearctic genera with those of the Australian and Neotropical Regions would be simply a waste of time, for the points of resemblance are extremely few, and such as they are they lead to nothing. It will therefore be seen from the above that next to the Nearctic Region, the Palearctic has a much greater affinity to the Indian than to any other, a fact which need not surprise us when we consider the great extent of their contact.

Having shewn this much we have next to deal with the peculiarities of the Region under our view. At the lowest computation 37 genera seem to be peculiar to it, though it is certain that species of several are regularly wont to wander beyond its limits in winter seeking a southern climate there to avoid the distress they would suffer in that of their birth. Of these genera 3 are to be apportioned to the Warblers, *Sylviida*; probably 2 to the Babblers *Timeliida*; at least 3 or perhaps 4 to the *Panurida*; 1 to each of *Parida* and *Isida*; 2 to the Flycatchers *Muscicapida*; 6 to the Finches, *Fringillida*; 1 to the Buntings, *Emberisida*, Starlings, *Sturnida*, Crows, *Corvida*, Woodpeckers, *Picida*, and the Sand-Grouse, *Pterocleida*, respectively; 2 to each of the Grouse, *Tetraonida*, and Pheasants, *Phasianida*; 1 to the Ducks, *Anatida*, and Cranes, *Gruidida*, respectively; 2 to the Plovers, *Charadriida*, and 5<sup>1</sup> to the Snipes, *Scolopacida*.

The European Subregion does not seem to possess a single genus which can be accounted absolutely peculiar to it, but it has two genera, each containing but one species—*Mergulus*, one of the *Alcida*, and *Pagophila*, belonging to the *Larida*—which do not appear to be elsewhere found in the Palearctic Region though both inhabit the most northern parts of the Nearctic. *Muscicapa* as now restricted<sup>2</sup> almost fulfils the conditions of peculiarity, but one species has been said to breed, though in small numbers, in Palestine.

The Mediterranean Subregion appears to have peculiar to it 4 genera of *Sylviida*, and 1 of *Larida*; but some 22 more belong to it and to no other part of the Region, though having a wider range outside of the latter. Of these there are 8 common to both the Ethiopian and Indian Regions, namely, 1 of *Vulturida*, 3 of *Falconida*, and 1 of *Tetraonida*, *Anatida*, *Glareolida*, and *Cursorida* respectively. Confined to the same Subregion and the Ethiopian Region are 11, to wit, 1 of *Turdida*, 1 of *Sylviida*, 1 of *Timeliida*, 1 of *Laniida*, 2 of *Fringillida*, 1 of *Emberisida*, 1 of *Sturnida*, 1 of *Alaudida*, 1 of *Vulturida*, and 1 of *Charadriida*; while having the like relation to the Indian Region are 2—1 belonging to *Cuculida* and 1 to *Otidida*. Of the family last named another genus (*Eupodotis*), which only just makes its appearance in Morocco, ranges over Africa, India, and Australia; and a genus of *Anatida* (*Erimatura*) is represented in America and Australia as well as in Africa.

The Atlantic Islands, which must be regarded as outliers

<sup>1</sup> One of these last has for a wonder received no name from systematists, but its generic separation seems on several grounds expedient. It is that which would have for its type the *Tringa platyrhynchos* of Temminck.

<sup>2</sup> That is excluding *Buteo*, *Erythrostrarna*, and other kindred groups, as well as the purely Ethiopian forms which have been by some systematists attached to *Muscicapa* proper.

of the Mediterranean Subregion, offer some peculiarities too remarkable to be here left unnoticed. First we have the Azores, the subject of an excellent monograph by Mr Frederick Godman,<sup>1</sup> in which is contained the result of his own investigations in that group, as well as those of his predecessors. There is a general tendency among Azorean Birds to vary more or less from their continental representatives, and this is especially shown by the former having always darker plumage and stronger bills and legs. In one instance the variation is so excessive that it fully justifies the establishment of a specific distinction. This is the case of the Bullfinch of the more eastern of these islands (*Pyrrhula murina*), the male of which, instead of the ruddy breast of its well-known congener (*P. vulgaris*), has that part of a sober mouse-colour. A similar sombre hue distinguishes the peculiar Chaffinch of the Canary Islands (*Fringilla teydea*), but to these islands as well as the Azores and Madeiras there belongs in common another Chaffinch (*F. tintillon*), which, though very nearly allied to that of Mauritania (*F. spodiogenia*), is perfectly recognizable, and not found elsewhere. Madeira has also its peculiar Golden-crested Wren (*Regulus maderensis*), and its peculiar Pigeon (*Columba trocas*), while two allied forms of the latter (*C. laurivora* and *C. bollii*) are found only in the Canaries. Further on this subject we must not go; we can only state that Mr Godman has shown good reason for declaring that the avifauna of all these islands is the effect of colonization extending over a long period of years, and going on now.

The Mongolian has the largest number of peculiar genera of any Palearctic Subregion. In *Sylviida* there is 1, in *Timidiida* 2, in *Panurida* and *Isida* 1 each, in *Fringillida* 3, in *Sturnida* and *Pterocleida* 2 1 respectively, in *Phasianida* 2, and in *Anatida* 1—or 13 in all; but, in common with the Indian Region, and that only, there are 10 of *Sylviida*, 4 of *Timidiida*, 1 of *Troglodytida*, 3 of *Liotrichida*, 1, rather doubtful in position, but possibly belonging to *Panurida*, 1 of *Isida*, 4 of *Muscicapida*, 1 of *Motacillida* and *Fringillida* respectively, 2 of *Sturnida*, 1 of *Picida*, 2 of *Strigida* and as many of *Columbida*, 1 of *Tetraonida*, 4 of *Phasianida*, and 1 generally referred to *Scolopacida*<sup>2</sup>—or 39 altogether. In common with the Ethiopian Region alone, the Mongolian Subregion has only 1 genus, and that belongs to *Motacillida*; but in common with both Ethiopian and Indian, though with these only, there are 1 of *Muscicapida* and 1 of *Laniida*; while 2 genera—1 of *Fringillida* and 1 of *Scolopacida*—belong equally to the Nearctic fauna: 2 genera, members respectively of the *Dicaida* and *Pitrida*, are common as well to the Ethiopian, Indian, and Australian Regions.

The Siberian Subregion seems to have but 1 genus peculiar. This is *Eurymorhynchus*, one of the *Scolopacida*; but as its breeding-quarters have never yet been discovered the matter must remain in doubt. One genus of *Larida* and 6 of *Alcida* are also common to the Nearctic Region, but do not inhabit any other Palearctic Subregion.

It would extend the present article far beyond all reasonable bounds were we to dwell upon more than a few of the curiosities of distribution which have been revealed by the continuous observations of European ornithologists. There is no need to travel out of our own island to meet with some of the most remarkable among them, and we may take that of the Nightingale (*Daulias luciniva*) as an

example. In England the western limit of the range of this incomparable songster seems to be formed by the valley of the Exe, which is only overstepped on rare occasions—Montagu having once heard it near Kingsbridge, while it is said to have been observed at Teignmouth and Barnstaple. But even in the east of Devonshire it is local and rare, as it also is in the north of Somersetshire, though plentiful in other parts of that county. Crossing the Bristol Channel it is said to be not uncommon at times near Cowbridge in Glamorganshire; but this seems to be an isolated spot, or at any rate there is no evidence of its being found elsewhere in Wales, or between that place and Tintern on the Wye, where it has been reported to be plentiful. Thence there is more or less good testimony of its occurrence in Herefordshire, Shropshire, Staffordshire, Derbyshire, and so on, to about 5 miles north of York, but not further. Along the line thus sketched out and immediately to the east and south of it, the appearance of the nightingale, even if regular, which may be doubted, is rare, and the bird exceedingly local; but in many parts of the midland, eastern, and southern counties it is abundant, and the woods, coppices, and gardens ring with that thrilling song which has been the theme of writers in all ages. There are many assertions of its occurrence in England further to the northward, but some of them rest on anonymous authority only, and all must be regarded with the greatest suspicion. Still more open to doubt are the statements which have been made as to its visits to Scotland, while in Ireland there is no pretence even of its appearance. No reasonable mode of accounting for the partial distribution of the Nightingale has hitherto been propounded: there is no peculiar kind of soil which it especially affects, or none, so far as we know, that it especially avoids; and the same may be said of its relations to the flora of this country. It is not so entirely *adscriptus globis* that it will not readily betake itself to new localities suited to its wants, when these have been formed within its natural limits, though they may be miles away from its ancient haunts. On the contrary, it is often one of the first birds to establish itself when a heath has been broken up, and plantations of trees thereon made have grown sufficiently to afford it the sheltering covert that it loves. This instance, taken from a bird whose habits have been so closely studied both in captivity and at large, and one which is so familiar, and in many places so numerous, that abundant opportunities are given for observing all that can be observed about it, shews how futile would be the expectation that in most cases we could at present, even if ever, satisfactorily account for the existing causes which limit the distribution of species. A vast majority of them, we know, have each its bounds, which virtually it cannot pass, and the case of the Nightingale in England, beyond the fact that its distribution is extremely well marked, and therefore has long attracted especial attention, has really nothing out of the common way in it.<sup>4</sup> In Europe, the neighbourhood of Copenhagen is the most northern point which our Nightingale is asserted to reach; but on the continent its range is less extended, and though abundant in Mecklenburg, it is not found in that part of Pomerania

<sup>1</sup> *Natural History of the Azores or Western Islands*, 8vo. London: 1870.

<sup>2</sup> The genus of this family here meant is *Syrhaptes*, the Three-toed Sand-Grouse, one species of which (*S. paradoxus*) overran Europe in astounding numbers in 1863, and effected a temporary settlement both in Denmark and Holland.

<sup>3</sup> This is *Ibidorhynchus*, which, until some details of its osteology are known, can hardly be placed without risk of error.

<sup>4</sup> When the history of the earth shall be really well and minutely understood, it seems quite possible that as much light will be shed on this and other particular cases of the same kind by a knowledge of the various changes and displacements which sea and land have undergone as has already been done by the same means in regard to many of the general facts of distribution. The results of the labour of the geologist are doubtless just as necessary to, and closely connected with, the work of the biologist, as those of the investigation of the historian are to and with the efficiency of the statesman; while, in return, the researches of the biologist are, or ought to be, of the greatest service to the geologist. The history of the earth is for a long period of time that of its inhabitants

which lies to the north of the river Peene, nor does it stretch so far to the eastward as Danzig. It occurs, however, sparingly on the Polish frontier, near Thorn, and is observed in Austria, Upper Hungary, and Gallizia. In Russia its distribution cannot be laid down with any degree of accuracy, but it does not reach the Governments near the Ural, though it is said to be plentiful in that of Kharkov, and it is known to visit the Crimea. Still further to the eastward it can be traced through Circassia, and as far as Kasbin in Persia. Southward of this imperfectly-drawn line it may be found as a winter-visitant even in Arabia, Nubia, and Abyssinia, as well as in Algeria, where it is reported as breeding, and it would seem to migrate thence so far as the Gold Coast. It is abundant in Spain and Portugal; but it is a stranger to Brittany, the western peninsula of France, just as it is to the western peninsula of England.<sup>1</sup>

One other example we may take, and this, though much less familiar, is equally instructive, as exhibiting some of the as yet unexplained peculiarities of distribution. It shall be from a Bird belonging to a very different Order from the last, having habits entirely dissimilar, and presenting in most ways a great contrast. The Kentish Plover (*Agriolais cantiana*), first determined from specimens obtained on the coast of that English county whence it takes its specific name, has its breeding-place in Britain limited to the pebbly beach between Sandwich and Hastings, and in other parts of the British Islands only occurs as a chance straggler. Yet this bird has as wide a range elsewhere as almost any that could be named—breeding not only abundantly along the greater part of the coasts of the temperate and warmer portions of the Old World north of the Equator, but also occasionally in the interior, as at the base of the Caucasus and in the *chotts* of the North African plains; while during its migrations it wanders to the Malay Archipelago and South Africa, or even seems most likely to be specifically identical with a Plover which is found on the west coast of America, from California southward—though this last has been described as distinct under the name of *A. nivea*.

Islands must always be a matter of the greatest interest to the student of Geographical Distribution, and we have already mentioned some peculiarities of those groups which belong to the Mediterranean Subregion of Europe. There are not many more here to be cited. Spitzbergen is supposed to have its peculiar species of Ptarmigan (*Lagopus hantelocurus*), though it is confessedly very nearly allied to the Rock-Ptarmigan (*L. rupestris*) which inhabits the Arctic portion of the American continent and islands, Greenland, and Iceland, but, except in the last-named country, does not occur in the Palæarctic Region. Iceland is also remarkable for being the headquarters of the noble Falcon (*Falco islandicus*) which takes its name therefrom, though this bird also inhabits the southern districts of Greenland, to say nothing of other countries; and in Iceland alone of the western portion of the Region does the beautiful Harlequin-Duck (*Histrioniscus torquatus*) breed. It is, however, known to inhabit North America and the eastern half of Siberia.

Coming nearer home, we have a remarkable case of restricted distribution in the Red Grouse (*Lagopus scoticus*), found (and in certain districts, as every one knows, numerously), in each of the three kingdoms composing the British Islands as well as in the principality of Wales. The details of its local distribution, as of that of all other birds which breed in Great Britain, have been carefully and concisely given by Mr More,<sup>2</sup> and we do not propose to con-

sider them here, but what is worthy of remark is that this particular species differs in no essential character save coloration from the Willow-Grouse (*L. albus*), which is an abundant bird throughout the whole of the northern parts of the Palæarctic Region from Norway to Kamchatka, and again throughout the same or even lower latitudes of the Nearctic Region from Alaska to Newfoundland. Its remains, as has before been said (page 731), have also been found in the south of France, associated with those of the Reindeer and Snowy Owl. It is not for us now to enter into any hypothetical discussion, but it is hard to resist drawing an inference that at a time, geologically speaking, not very recent, both these species of Grouse had a common ancestor, and that the severe winters to which it has for a long period been exposed have caused the Willow-Grouse to don the snowy garb that is characteristic of it and other species of the genus, the more so since we find it in its first plumage possessed of the coloured quills, which are precisely similar to those of the Red Grouse at the same age.

Other instances there are in which British-born examples of species common to the continent are in a less degree distinguishable from those of neighbouring countries. The Coal-Titmouse of England is to be recognised from that of continental Europe (*Parus ater*), and accordingly by some ornithologists it is regarded as a distinct species (*P. britannicus*), but the scanty remnants of the ancient pine-forests of Scotland are inhabited by birds between which and European examples no difference can be established. The home-bred Bottle-Titmouse of Britain, too, has, from its darker coloration, been accorded specific rank, but then we occasionally find continental birds of this species (*Acrochorda caudata*) varying in this respect, and the specific validity of the British form (*A. rosea*) can hardly be with consistency maintained. Indeed, as a matter of fact, nearly all our smaller birds can be distinguished by an expert from their continental brethren, and this mainly through their duller or darker plumage. The difference is not so great by any means as obtains in the case of the birds of the Atlantic Islands above mentioned, but it most unquestionably exists to a greater or less degree; and it is curious that an analogous state of things is observable in regard to many of the birds of Japan, a country which is subject to many of the same climatic conditions as the British Islands. It will be for future investigators to ascertain the cause of this similarity, we here only record the fact; but another remarkable instance of the forms of the western portion of the region being repeated in the far east, is found in the range of the two kindred species of the beautiful genus *Cyanopica*—the Blue Magpie of Portugal and Spain (*C. cyanea*) being replaced in Amoorland and Japan by a species (*C. cyanea*) so closely allied that some authorities refuse to acknowledge their distinctness, and yet throughout 130° of longitude no representative of either is found.

V. THE ETHIOPIAN REGION, comprising the whole of the African continent, except the Barbary States, besides the Cape-Verd Islands and naturally those situated in the Gulf of Guinea, as well as Madagascar and the Mascarene group from Réunion (Bourbon) to the Seychelles, and the large island of Socotra, and crossing the Red Sea to Arabia, is sufficiently well marked out in a geographical point of view. The Ghor, or valley of the Jordan and the depressed basin of the Dead Sea, has been before mentioned as an outlier of this Region, the north-eastern part of which melts into the Palæarctic between Palestine and the Persian Gulf. There, and apparently there only, do its boundaries admit of no precise definition. Some zoogeographers seem inclined to extend its limits further to the eastward, through Beloochistan and even beyond the Indus; but though the desert-forms of a large portion of that tract of country are

<sup>1</sup> Cf. Yarrell, *British Birds*, ed. 4, vol. I, pp. 315-318, & *Ibid.*, 1846, pp. 1-27, 119-143, 425-464.

undoubtedly closely allied to, if not identical with, the denizens of similar districts in Africa, yet it must be remarked that such forms should be regarded in much the same light as those which frequent wide seas, and that the determination of a desert-tract must therefore depend rather on the fauna which inhabits its islands—as we may term the oases which, whether plentifully or rarely, stud its surface—rather than on the fauna of the desolate space which surrounds these fertile and more favoured spots. Still, it is hardly to be denied that the influence of Ethiopian types is to be discovered in Sindh, Gujerat, and even further in the Indian peninsula. In the Ethiopian Region we again find a number of the sub-class *Ratites* in the very specialized form *Struthio*—the Ostrich—and this ranges, or did range, from the immediate vicinity of the Cape of Good Hope to the confines of Algeria in the north-west, and to the banks of the Euphrates in the north-east.<sup>1</sup> It is even possible that within historic times it penetrated much further to the eastward and reached Sindh at least, and if this be so, the fact would lend colour to the proposed inclusion of that country within the Ethiopian Region.<sup>2</sup> But without concerning ourselves with speculations of this kind, there is enough and to spare which marks the Region as one of the chief zoological portions of the globe, despite the mystery which still hangs over its interior and at present completely defies any attempt to trace the boundaries of its Subregions or provinces beyond a comparatively little distance from the coast.

So large a portion of the Ethiopian Region lies between the tropics that no surprise need be expressed at the richness of its fauna relatively to that of the last two Regions we have considered. Between 50 and 60 families of land-birds alone are found within its limits, and of them at least 8—*Buphagida*, *Eurycerotida*, *Musophagida*, *Irrisorida*, *Leptosomida*, *Coliida*, *Serpentariida*, and *Struthionida*—are peculiar; but it is singular that of them only 2 belong to the Order *Passeres*, a proportion which is not maintained in any other tropical Region. The number of peculiar genera is too great for them to be named here; some of the most remarkable, however, especially of those peculiar to one of its Subregions, whose Bird-life has been differentiated to a degree that is very extraordinary, will presently be mentioned.

The subdivision of the Ethiopian Region is perhaps accomplished with less difficulty than in the case of the more temperate tracts with which we have lately had to do. Bounded on the north by the Mediterranean Subregion of the Palearctic Region, we have a Subregion extending from the Cape-Verd Islands on the one side of the continent to Socotra on the other; and with this we must comprehend all the Asiatic territory, whatever be its limits, which is, for zoogeographical purposes, to be annexed to the Ethiopian Region. On the West Coast of Africa the southern frontier of this Subregion, which we may call the "Libyan,"<sup>3</sup> seems to lie a little to the northward of lat. 10° N.; but, owing to the unexplored state of the country, we quickly lose trace of its confines. We may perhaps

presume that they more or less follow that parallel to somewhere about long. 15° E., and then trend in a south-easterly direction. On the East Coast the frontier of the Libyan Subregion extends from near Cape Guardafui in a south-westerly direction towards the system of the Great Lakes, all the waters flowing to which it may be held to include; and is then succeeded by the "Mosambican" Subregion, which continues perhaps to Sofala. Beginning on the West Coast, where the Libyan Subregion stops, we have another Subregion, the "Guinean," comprising the seaboard from Sierra Leone to somewhere about Angola; but as to how far inland this penetrates we are absolutely without information. The rest of continental Africa forms what may be called the "Caffrarian"<sup>4</sup> Subregion, while Madagascar, the Comoros, and the widely-scattered Mascarene Islands, constitute a fifth Subregion, the most distinct and remarkable of all, and for this we may most reasonably use the name "Madagascanian."

(1.) *The Libyan Subregion*, the first we have separated, may perhaps be broken up into four provinces—the Arabian, Egyptian, Abyssinian, and the Gambian; but it must not be expected that all their respective boundaries can be distinctly drawn—those of the first excepted, which, however, seems to be the one that has precisely the fewest positive characteristics, and the propriety of its recognition, except on purely geographical grounds, is most questionable. We may doubt whether it has more than half-a-dozen peculiar species; but then we know next to nothing of the zoology of any part of Arabia, save the Peninsula of Sinai and the desert of the Tih. As before mentioned the Ostrich occurs here, but its present northern or eastern limits are indeterminate; we know, however, that within recent years it has been killed in the desert of Belka, just on the other side of the Dead Sea. The species which seem to be peculiar to the Jordan basin are—*Crateropus chalybanus*, *Nectarinia osea*, *Passer moabiticus*, *Amegrus tristrami* and *Caprimulgus tamaricis*, the last but one of which in its name commemorates Canon Tristram, the naturalist to whom we owe most of our information as to the fauna of this singular district.

The Egyptian province, so far as regards the valley of the Lower Nile, is remarkable for being, as already stated, overrun by migrants from Europe during the winter, and since it is chiefly from the observations of travellers at this season that most of our knowledge is derived, it is perhaps not very wonderful that many zoogeographers are inclined to include this district within the Palearctic Region. The number of species which occur in Egypt and Nubia, as given by Captain Shelley,<sup>5</sup> is 362, but many of them he says are of doubtful occurrence. Of these more than 230 are natives of the Palearctic Region; but only between 50 and 60, or about one quarter of them, remain to breed in Egypt, and of this number a considerable proportion do not breed in Europe, but only in the Barbary States. The extra-Palearctic character of the Egyptian ornith is thus fully established.

Respecting the Abyssinian province very full particulars are included in the lately-completed work of Dr von Heuglin;<sup>6</sup> but for our purpose it is not easy thence to ascertain the precise features of its avifauna, since he has not discriminated between it and the Egyptian. North-east Africa, according to him, has about 950 species of Birds, of which he reckons about 325 as migrants from Europe or Western Asia—that is to say, from the Palearctic Region. Of these 113 breed in that Region, as well as in North-eastern Africa; 294 have been observed in the Bar-

<sup>1</sup> Xenophon, *Anabasis*, I. v. 2.

<sup>2</sup> For all that can be said as to the supposed former extent of the Ostrich's range in Asia, and, indeed, for the best account of this Bird that has ever been published, see Finch and Hartlaub, *Vögel Ost-Afrikas* (pp. 597-607), forming the fourth volume of Von der Decken's *Reise in Ost-Afrika* (Leipzig and Heidelberg: 1870). Fossil remains of *Struthio* have been indubitably recognized from the Sivallik hills in India.

<sup>3</sup> In using this name the writer follows Blyth (*Nature*, III. p. 428, March 30, 1871). Mr Sharpe, whose kind assistance in preparing this portion of the present treatise the author gratefully acknowledges, has proposed to call this Subregion the "Abyssinian," from its leading characteristic being most evident in that country, but that name would seem to be better applied to a province, and accordingly, here a more general designation appears preferable.

<sup>4</sup> Again following Blyth (*loc. cit.*)

<sup>5</sup> *Handbook to the Birds of Egypt*. London: 1872.

<sup>6</sup> *Ornithologie Nordost-Afrikas*. Cassel: 1859-75.

bary States; 438 are common to the West Coast, but whether to the Guinean Subregion, presently to be treated, or only to the Gambian province of the Libyan, is not stated; 318 are common to South Africa or the Caffrarian Subregion, and 253 only to the Mosambican; while 215 are peculiar to the district to which his work especially relates; the last statement being the most important for our present use, since it cannot be doubted that nearly all these 215 species are peculiar to the Abyssinian province, which may be taken as extending from about the southern frontier of Dongola to the Victoria Nyanza, and from the Koesanga River (long. 27° E.) to Cape Guardafui. One of the most wonderful forms of birds peculiar to this province is the gigantic Whale-headed Stork, *Baleniceps rex*. Of Socotra we know far too little to determine its provincial affinity.

Of the Gambian province we cannot say much, through want of materials to convey any definite notion of its character; and we are only able to confirm the general belief that it has a good deal in common with the Abyssinian, next to be mentioned, for without lists carefully drawn up by those who have a special knowledge of the avifauna of a country, or the power to compile such for oneself, which in this case the present writer does not possess, any attempt at a critical examination of its details would be rather misleading than otherwise. The province probably lies between lat. 18° and lat. 10° N., but whether it preserves those limits in the interior, whether it passes directly into the Abyssinian, or whether another province intervenes, are questions that cannot be now decided. It would seem to have in common with the East Coast several very characteristic species, of which *Buphaga africana*, *Vidua paradisæa*, *Parus leucopterus*, *Corythornis cyanostigma*, *Coracias naviæ*, and *Tocxus nasutus*, with *T. erythrorhynchus*, may be mentioned.

To the Gambian province belong the Cape-Verd Islands, which, out of 17 or 18 Land-birds enumerated by Dr H. Dohrn (*Journ. für Ornith.* 1871, pp. 1-10), seem to have 2 peculiar species—a Sparrow (*Fringillida*) and an aquatic Warbler (*Sylviida*).

(2.) *The Guinean Subregion* is the next to be treated, and occupies what is commonly spoken of as the "West Coast" of Africa, extending from Sierra Leone to the south of Congo, while its breadth is a matter of the greatest uncertainty. Hitherto no catalogue even of its birds has been published, for the work of Dr Hartlaub<sup>1</sup> comprehends also those of the Gambian province of the Libyan Subregion, while, admirably executed as it was at the time of its appearance, so much has since been done by collectors in this part of Africa, and by those who in Europe have examined their collections (especially Professor Barbosa du Bocage and Mr Sharpe), that its results must be regarded as out of date. Yet no good, and much harm, would follow from any attempt to generalise on the facts thus recorded, at various times and in various publications, except it were made by one especially acquainted with African ornithology; and we must therefore, perforce, leave the continental portion of this Subregion without trying to exhibit its particular characteristics. Respecting the islands belonging to it, however, somewhat may be advanced with more confidence. The chief of these are four in number—Fernando Po, Prince's Island, that of St Thomas, and Annobon. The first, lying in the Bight of Biafra, was once believed to possess a very peculiar avifauna; but one by one, all, or nearly all, of the supposed peculiar species have been found on the mainland, until it seems likely to have none whatever. Prince's Island, situated outside the Bight, but still lying within the Gulf

of Guinea, has been said to possess 1 peculiar genus, *Cypopterus* (of perhaps uncertain affinity, though it has been referred to the *Timeliida*), comprising a single species, (but this has since been sent from the Gaboon) and 6 other species—1 each of *Dicaeida* and *Hirundinida*, and 2 of *Ploceida* and *Columbida* respectively. A curious assertion has been made with regard to this island, namely, that it is not inhabited by any Diurnal Bird-of-prey, all such being, it is said, driven off by the Grey Parrots (*Pittacus erithacus*) which there abound. The island of St Thomas, lying nearly or just under the equator, also has 6 peculiar species, belonging respectively to the *Turdida*, *Dicaeida*, *Oriolida*, *Ploceida*, *Columbida*, and *Strigida*; while another species of the family last mentioned is common to this and Prince's Island, but seems to be found nowhere else. Of Annobon we know nothing.

(3.) *The Caffrarian Subregion* has its inland boundaries as ill-defined as either of the preceding, yet its distinctive features are much more marked—a fact which is doubtless to some extent explained by so great a portion of it lying without the tropic. Though this part of Africa has perhaps received the closest attention from ornithologists, the several labours in various districts of the Subregion of Levaillant and Jules Verreaux, Andersson and Andrew Smith, Mr Layard and Mr Ayres, assisted at home by Sundevall and Mr Gurney, all require digesting before their bearings upon the subject of geographical distribution can be fully comprehended; and, as in the cases previously mentioned, the careful collation and comparison of different lists can only be usefully accomplished by one who has a special knowledge of the objects treated of by those writers, and any attempt to attain this end by an inexperienced person would be dangerous. Only one island can be with certainty affiliated to this Subregion, and that is St Helena, where the indigenous Land-birds, if any there were, have probably been extirpated with most of its original and peculiar flora. Yet, curious as it may be, it seems to be a fact that this isolated spot possesses a peculiar Water-bird, albeit it is of a group which greatly affects dry places. This is a small Ringed Plover (*Agialitis sancta-helena*), and, though belonging to a genus the members of which are remarkable for very wide distribution, it is not known to have occurred off the island. Tristan da Cunha, commonly assigned to the Ethiopian Region, and therefore to this Subregion, seems, from reasons before stated, to have at least as much affinity to the Neotropical, and Ascension appears to have no indigenous Land-birds whatever, so that its appropriation must remain in doubt.

(4.) *The Mosambican Subregion* next follows, and its relations to the Abyssinian the numbers already quoted from Dr von Heuglin will have shewn, but these must be taken with caution, since the limits of the Subregion are so indefinite. Whether we should comprehend in it the whole of the country drained by the Zambesi and its tributaries seems to be very uncertain; but, judging from the collections he has received, Mr Sharpe is now inclined to think that this part has more affinity to South Africa. The general uniformity of distribution which obtains among the Birds of all the tropical portion of the Region, especially noticed by Dr Kirk in writing on those of Zambesia (*Ibis*, 1864, p. 307), requires much fuller geographical details than are at present available to entitle us to form any very decided opinion, though the in most respects excellent monograph of Drs Finsch and Hartlaub (see note at page 758) gives ample information as to the literature and descriptions of the 448 species which, according to those learned authors, constitute its avifauna, and no attempt can possibly be made to subdivide the Subregion into provinces. Lying off its coast are three considerable islands, Pemba, Zanzibar, and Monfia, but as yet there is no reason

<sup>1</sup> *System der Ornithologie West Africa's*. Bremen: 1857.

to expect that they have any very important bearing from a zoogeographical point of view. Zanzibar is the best known, and that seems to have a few species peculiar to it—for instance, *Laniarius salima*, *L. orientalis*, and *Franco-linus kirki*,—but further investigation may prove that some of them also occur on the mainland.

(5.) *The Madagascarian Subregion* remains for consideration, and this from its insularity is obviously well defined, while a good deal of attention has been paid to its remarkable peculiarities. Indeed, except New Zealand, it may be safely deemed the most peculiar Subregion on the earth's surface, while from the richness and multifariousness of its animal and especially of its ornithic population, New Zealand cannot for a moment be compared with it. Its principal subdivision, Madagascar itself, once possessed in the extinct gigantic bird *epyornis* a form of *Ratita*, not less singular than the Ostrich or the Moe, and though some writers would fain see in the remains of this marvellous creature a realization of Oriental fables respecting the Roc, not a vestige has been recovered which can be declared to belong to any period to which history or even legend can reach, and Arabian tales are not corroborated by the hypothesis of Professor Bianconi, while they are virtually contradicted by the researches at home of M. Alphonse Milne-Edwards, and Herr von Nathusius, and of M. Grandidier abroad. Three also of the satellite islands—Mauritius, Réunion (Bourbon), and Rodrigues—possessed brevipennate Birds totally dissimilar from but hardly less singular than the *epyornis*, and here the Dodo and its kindred, together with other Birds now extirpated, flourished peacefully till they felt the power of man and his agencies. But brief particulars of these extinct forms have already been given (pp. 732, 733), and we must now restrict ourselves to the consideration of those which survive.

This Subregion is easily divided into two provinces—Madagascar and the Mascarene Islands; but then it becomes a question whether the Comoros should not be considered to form a third, and also how the Seychelles should be treated. Not without scruples we propose to refer the latter to the Mascarene province as an outlying group, and to regard the former in the same light in reference to the Malagash province or Madagascar proper.

Long studied as the Birds of Madagascar have been, hardly a year now passes without some new form being added to its list; and what is especially remarkable is that a very large proportion of the additions are not merely new species of genera previously known, but are the types of undeniably good and new genera, while it would seem also as if many of these had a very limited range in the island, for every fresh district visited by a collector is almost sure to produce something which neither he nor his predecessors have met with in other parts, though the actual distance between the localities may be inconsiderable. The number of genera of Land-birds amounts to nearly 100, and of them almost one-half are peculiar to the Subregion; by far the greatest number of them belonging to the Order *Passeres*, though the *Picariæ* are also well represented by peculiar genera, and the *Pittaci* and *Columbæ* possess to a certain extent the same characteristics. Many of the genera belonging to the two Orders first named can be but with difficulty referred to any family existing elsewhere, but for fear of exaggerating the singular character of the Subregion we prefer regarding two only of these families as absolutely peculiar. These are *Leptosomida* and *Eurycerotida*, the single genus and species constituting each of which it seems impossible to place with any other family. Almost the same may be said of the genera *Brachypteraciæ*, *Geobiastæ*, and *Atelornis*, which may perhaps be linked in one group, though to what family it should be attached seems very doubtful; and there is

*Philopitta* so isolated that by one author it is referred to the *Turdida*, by another to the *Paradisæida*, and by a third to the *Pittida*, the probability being that each assignment is wide of the mark. But the *sviffans* of Madagascar is not entirely composed of such singularities as these. We have homely genera, even among the *Passera*, occurring there, such as *Acrocephalus*, *Motacilla*, *Pratincola*, and *Alauda*, while a *Cisticola*, which, though it has received a distinct trivial name, is undistinguishable from the well-known Fantail-Warbler (*C. schaniicola*) of southern Europe, Africa, and India, has long been known as an inhabitant of Madagascar. But there are also species, though not *Passerine*, which are absolutely identical with those of Britain—*Aluco flammatus*, *Coturnix commensis*, *Porzana pygmaea*, and *Podiceps minor*—all of them common in the island. The number of species of Birds hitherto found in Madagascar cannot be safely put at less than 200, of which 120 are Land-birds, and of these latter fully 100 are peculiar. The Comoros, so far as they have been explored, have yielded more than 20 Land-birds, of which 12 at least are peculiar, the remainder being common to Madagascar; but, no doubt, throughout every part of the Malagash province there is room for further discoveries.

The principal islands of the Mascarene province have had their original fauna so largely destroyed by colonization, as has just been stated, that we are hardly in a condition to judge its peculiarities accurately. Mauritius and Réunion, lying within sight of each other, and possessing about the same number of existing species, seem not to have more than 3 in common. There is 1 genus (*Oryzotus*) belonging to the *Campephagida* which is peculiar to these two islands, and represented in each by a distinct species. Réunion also had within the memory of man yet living a peculiar genus of *Sturnida*—*Fregilupus*. Rodrigues is now known to possess only 4 species of Land-birds natural to it; and of these 3 are peculiar, 1 being the Parakeet before mentioned as on the verge of extinction, and another an aberrant form of *Drymacca*, pointing possibly to a common origin with certain Indian species.<sup>1</sup> The Land-birds of the Seychelles which have not been introduced are 14 in number, and of these 12, according to Mr Edward Newton (*Ibis*, 1867, p. 359), are peculiar; but there is no good genus which can be so termed. Finally, we may mention that the small island of Aldabra has a Dove which has been described as a distinct species, and that of St Denis a Water-hen which probably merits the same remark. Taken as a whole, we cannot but be struck with the force of the evidence as to the land-connection which must once have existed—though not necessarily all at once—between the various units forming the whole Subregion. Even the scanty remnant that is left enables one to see how the denizens of its most distant quarters represent one another, a clear token of their long-continued isolation and the working of a differentiating power. But this is no place to pursue theories.

#### VI. THE INDIAN REGION<sup>2</sup> completes our survey of the

<sup>1</sup> This same leaning towards India is also indicated by the genus *Hypipetes*, one of the *Turdida*, all the members of which, save 4, belong to the Indian region, and these four are peculiar respectively to Madagascar, Réunion, Mauritius, and the Seychelles, and it would be easy to cite similar cases of isolated Birds of either the Indian or Ethiopian Region which have their nearest relatives natives of the other.

<sup>2</sup> It must be mentioned that objection has frequently, and not without show of reason, been taken to the name "Indian" applied to this Region; and, except for the awkwardness of the title, we must admit that "Indo-Malayan" would have most likely been found a more expressive and suitable epithet, since what we commonly mean by "India" forms but a small and perhaps not the most characteristic portion. Mr Wallace proposes to use the name "Oriental," against which it may be not unreasonably urged that it errs on the side of vagueness, just as "Indian" does on the side of particularity. On the

globe; and its boundaries, so far as they can be defined, have been already sketched out when treating of the adjoining areas. Large as is its extent, and greatly varied as are its physical features, it would seem to have but 2 peculiar families of Birds (*Phyllornithidae* and *Eurylamida*) out of upwards of 70 which occur within its limits. There is peculiar difficulty in determining the zoological Subregions and provinces into which this Region should be separated. While the fauna of some districts, or even larger portions, has been studied so that we possess a knowledge of them almost as full as of any country in the world, Europe and the tracts of other Regions settled by Europeans alone excepted, the greater part is not much better known zoologically than is the centre of Africa. Yet we cannot treat the Indian Region with the same audacity of ignorance that we did the Ethiopian, drawing our boundaries here and there in a manner which the experience of a few more years will very likely prove to be exceedingly wide of the mark, for our acquaintance with the Region now under consideration is such as to convince us that throughout its whole extent there are districts, large or small, which have an unmistakable affinity to one another, and yet appear to be cut off from all communication with their neighbours. True it is that we may readily account for this on the ground that the similarity to be observed is due to corresponding elevation above the sea-level, and that throughout the whole Region the hill-countries are, as a rule, disconnected; but such an explanation does not make our task the easier, and we are filled with the consciousness that we cannot map out the Indian Region according to the method we have hitherto followed. We find the characteristics of the Himalayan avifauna shewing themselves not only on the highlands of Southern India and Ceylon, but far away to the eastward also, as in Formosa, Hainan, and Cochin China, and again repeated in a lesser but still perceptible degree to the southward in the mountain ranges of Malacca and Sumatra. This then being the case, we think it better to follow in the main the scheme adopted by Mr Elwes, to whose essay on the geographical distribution of Asiatic Birds we have before referred (page 754). Right or wrong in his results, he has the merit of having arrived at them, as he tells us, contrary to a certain bias which he had entertained at the beginning of his investigations, and these are marked by uncommon care and a diligent study of all the means of information at that time available to him. Mr Elwes would establish three Subregions—the "Himalayan" "or Hirmalo-Chinese," the "Indian" (proper), and the "Malayan."

(1.) *The Hirmalo-Chinese Subregion*, according to his view, includes all the middle slopes of the Himalayan range, from an elevation of about 3000 to 12,000 feet, and, beginning with Cashmere, extends through Nepal, Bhotan, the highlands of Assam, and thence, marching with the as yet undetermined frontier of the Palearctic Region, to the sea-coast of China. To this Subregion belong the islands of Formosa and Hainan, and it not only includes a great part of China proper, but probably the whole of Cochin China and Siam, with the hill-country of Tennasserim and Burmah, merging into the Malayan Subregion somewhere about lat. 12° N. In its western part, he observes, it is merely a narrow border-land, in which the members of two very different faunas meet, and, being inhabited during some part of the year by nearly all the principal Palearctic genera, and those of the proper Indian Subregion, probably includes some of the richest portions of the world. Besides this, as already remarked, its influence is felt far to the southward, even in the islands of Ceylon and Sumatra.

whole, it seems as though "Indian," having been the distinguishing term first applied to this region, had better be retained.

From what has been said above as to the way in which some of the Subregions of the Indian Region are broken up, and this Subregion especially, it is useless to attempt any partitioning of them into true zoological provinces. We can only follow Mr Elwes in taking the various countries in succession, and stating what is known of them. Cashmere is the first. Here there seems to be 171 Land-birds, referable to 116 genera; of the latter, 34 have a wide range, 32 are characteristic of the Palearctic Region, 29 of the Indian, and 21 peculiar to or characteristic of the Hirmalo-Chinese Subregion. There is only 1 species peculiar to the country—a very normal Bullfinch (*Pyrrhula*) belonging to *Fringillidae*. *Cephalopyrus*, an aberrant Titmouse (*Parida*), and once thought to be a peculiar genus, extends eastward so far as Simla. Of the species 70 seem to be peculiar to the Himalayan district, and 30 are common to the Palearctic Region.

Nepal is the next country of which we know enough to give any satisfactory account; and, indeed, thanks to Mr Hodgson's labours in years gone by, our knowledge of its zoology is very tolerably complete, though of late years little has been added to it. Its rich avifauna is said to consist of 553 species of Land-birds, belonging to 394 genera; of the latter, 62 are of wide range, 30 characteristic of the Palearctic, and 122 of the Indian Region, while 80 are peculiar to, or characteristic of, the Himalaya. Of the species there are 330 peculiar to the Himalayan district, and 60 common to the Palearctic Region.

The small state of Sikkim seems to be richer still. Excluding the *Accipitres* there are here found 423 species of Land-birds, of which 270 do not occur out of the Himalaya, except as migrants or stragglers. Of these, 63 belong to genera of wide range, 60 more are of Palearctic distribution, and 154 are nearly peculiar to the Indian Region, while 146 are peculiar to, or characteristic of, the Hirmalo-Chinese Subregion. Passing to Assam, the hills to the north and east of which, however, are very little known, its ornithic character seems greatly to resemble that of Sikkim; but we have from its southern boundary a few genera which are not actually found in the Himalaya, such as *Anthreptes*, *Turdinus*, and *Rhytoceros*, belonging respectively to *Nectarinidae*, *Troglodytidae*, and *Bucerotidae*, while we are acquainted with only 16 species which are not found also in Sikkim, and of these one-half are Burmese.

Burmah must be taken next, though a district intervenes of which we are quite ignorant, and this country, its highlands especially, requires much more exploration, but the valley of the Irrawadi, Aracan, and Pegu are very fairly known. Of 373 species of Land-birds, 97 are common to India, and the rest to the Malay peninsula. 193 more are found in India, and 27 in the peninsula alone, while 46 are peculiar to Burmah or to Burmah and Tennasserim. In Tennasserim, taking it to extend from Martaban to the isthmus of Krau, we have 313 species of Land-birds, 93 being common to India and the rest of the peninsula, 117 more being found in India, and 56 in the peninsula alone, while 47 are peculiar to Tennasserim or to Tennasserim and Burmah. This country is especially rich in species of the peculiarly Indian family *Eurylamida*, possessing a majority of the known forms.

Lying in the Bay of Bengal are two remarkable groups of islands—the Andamans and the Nicobars—which the authority we are following would, from the similarity of their avifauna to that of Pegu, include in this Subregion. Lord Walden, however, thinks (*Ibis*, 1873, p. 297) the former have a greater affinity to the highlands of India south of the Himalaya and west of the Brahmapootra, and Mr Hume (*Stray Feathers*, ii. p. 136) considers both groups to form an outlying bit of the proper Indian Subregion on which many foreign intruders have established

themselves. It is certain that many genera, or even families, which are common in Burmah are wanting in the Andamans, such as the *Timelidæ*, *Pittidæ*, *Eurylamidæ*, and *Bucerotidæ*, though a peculiar form of the last occurs on Narcondam, an island between the Andamans and Burmah, and there is an extreme paucity of several other families. Still the Andamans possess an avifauna of some 155 species, 17 of which (all Land-birds) are peculiar. The precise number of species found in the Nicobars is not explicitly stated by Mr Hume, but he gives 10 as peculiar to that group, which is inhabited by two very noteworthy forms—*Calonax*, a very remarkable genus of *Columbidæ*, widely spread throughout the Malayan archipelago, and a species of *Megapodius*, belonging to one of the most characteristic families of the Australian Region. The presence of these two forms would almost incline one to remove the Nicobars from the Subregion to which they have generally been assigned, and refer them rather to the Malayan Subregion.

It is now necessary to retrace our steps northward and notice China;<sup>1</sup> but this is a branch of the subject on which it is as yet impossible to form an opinion. The chief authority on Chinese ornithology is unquestionably Mr Swinhoe, who has for so long a time laboured in various parts of that country equally as a public servant and a naturalist; but the results of his multitudinous contributions to our knowledge of its avifauna have never yet been tabulated, and probably their author is alone competent to perform this task without running into errors that would be disastrous in their consequences. In his latest catalogue of the Birds of China,<sup>2</sup> he enumerates 675 species as found in that country and its islands; but valuable and carefully-drawn up as this list is, it is impossible to eliminate therefrom the species not strictly belonging to that part of the Celestial Empire which lies within our present bounds; or even were this possible, an intimate acquaintance with its ornithology would be required to separate the birds-of-passage from the residents, and still more to classify them according to their several Orders and families. Add to this, that assiduously as Mr Swinhoe has himself worked in the field, and diligently as he has availed himself of such information as he could obtain from other trustworthy observers, only the outskirts of this great territory have, with few exceptions, been examined. Much is it to be hoped that he will be able in due time to bring forth the ripe fruit of his labours, but meanwhile the attempt to elucidate the peculiarities of the avifauna of China proper, that is, south at least of the Yangtze-kiang and of Cochin China, would be vain if not misleading.

The two principal islands lying off the Chinese coast, however, are in a different condition. One of them has been extremely and the other tolerably well ransacked by Mr Swinhoe. In Formosa he has found 144 species, referable to 102 genera, of which 98 are found in the Himalayan Subregion, and 70 in the Malayan. The species may be thus assorted:—74 belong to wide-ranging genera, 47 to genera common to the Himalayan and Malayan Subregions, 18 are peculiar to, or characteristic of, the former Subregion, and 5 to China itself; 18 are not found in the Malayan Subregion, and no less than 34 are peculiar to the island. For Hainan Mr Swinhoe has enumerated 130 species belonging to 96 genera, of which latter 86 are common to the Malayan Subregion, and 93 to the Himalayan. Of the species 54 belong to wide-ranging genera, 59 to genera characteristic of the Indian

and 16 of the Palearctic Region, while 16 are believed to be peculiar to the island.

(2.) *The Indian Subregion*, still following Mr Elwes, is the next to be considered. This consists of the remainder of the peninsula of India lying to the south and west of the last, as well as of the island of Ceylon. Its partition into provinces has been several times attempted, and doubtless the method proposed by Mr Blanford, when treating of the geographical distribution of Indian Reptiles,<sup>3</sup> is one of the most reasonable, but even this may perhaps be premature,<sup>4</sup> and here it seems preferable to abstain from doing more than consider, so far as materials are available, the avifauna of the various districts of which it is composed—the more so since the extraordinary impulse given to the study of ornithology in India by the publication of the late Dr Jerdon's work<sup>5</sup> will doubtless in a few years place the whole subject in a very different light, for the number of Indian ornithologists is grown so considerable that that country has now a journal especially devoted to the record of their observations.

Beginning in the north-west with the Punjab, we have as yet no complete list of the Birds of this most important district, and we can only infer that we shall here find the Malayan influence at its least, and the Palearctic at its greatest; but descending the Indus to Sindh we have a discursive account of its ornithology by Mr Hume,<sup>6</sup> from which Mr Elwes gives the following results:—of 150 species observed, 41 are peculiarly desert-forms, and as such either very nearly allied to or identical with the like forms of the Palearctic and Ethiopian Regions; 40 are peculiar to the Indian Subregion, 8 are common to the Malayan, 4 to the non-desert portions of the Ethiopian, and 12 to the similar parts of the Palearctic Region, while 45 do not come under any of these heads. Omitting the desert-forms as not leading to any just conclusion, it would appear that Sindh has less affinity to the Ethiopian Region than to the Palearctic, that is to say, to its Mediterranean Subregion. The very remarkable district of Cutch yielded 115 Land-birds to Stoliczka,<sup>7</sup> and these were mostly migrants or common Indian species of wide range.

Of Rajpootana and Central India we know very little, but near Goona, about 200 miles to the south of Agra, Dr King some years since observed 116 species of Land-birds;<sup>8</sup> and more lately Mr Adam has noticed 171 species of Land-birds around the Sombhar Lake in its western portion.<sup>9</sup>

We must next turn eastward to Oudh, wherein Col. Irby (*Ibis*, 1861, p. 217) obtained 108 species of Land-birds, but of these 23 were found only on the hills of Kumaon. There seems to be a remarkable absence of many of the most widely-spread genera of the Region, and many forms generally common to Africa are also wanting; but no doubt Mr Brooks, who has of late industriously investigated this portion of the country, will be able to supply some of these unaccountable deficiencies.

We may judge of what are politically known as the "Central Provinces" of India, as well as of Bundelcund, Malwa, and Chota Nagpore, forming the "Gangetic" sub-province of Mr Blanford, from observations made by that gentleman and Colonel M'Master,<sup>10</sup> wherein 190 species of Land-birds are enumerated, of which 38 have a very wide range, 57 belong to widely-ranging genera but are almost

<sup>1</sup> Of China proper Mr Elwes says little, but he includes Eastern Tibet in this Subregion. The present writer, however, is disposed to refer that, or at any rate the scene of Père David's discoveries, to the Palearctic Region.

<sup>2</sup> *Proc. Zool. Soc.* 1871, pp. 327-343.

<sup>3</sup> *Journal of the Asiatic Society of Bengal*, 1870, pp. 335-376.

<sup>4</sup> Compare Dr Günther's remarks, *Zoological Record*, vii. p. 67.

<sup>5</sup> *The Birds of India*. Calcutta: 1862-64.

<sup>6</sup> *Stray Feathers*, i. pp. 44-49, 91-289, 419-421.

<sup>7</sup> *Journal of the Asiatic Society of Bengal*, 1872, pp. 211-258.

<sup>8</sup> *Op. cit.* 1868, p. 208-218.

<sup>9</sup> *Stray Feathers*, i. pp. 361-404.

<sup>10</sup> *Ibis*, 1867, p. 461; *Proc. As. Soc. Beng.* 1869, p. 104; *Journ. As. Soc. Beng.* 1871, pp. 207-216.



confined to India, 37 to genera common to tropical Africa and India, 8 to genera of Ethiopian type, and 53 to purely Indian genera.

Pursuing our way southward we come to the Deccan or table-land of India, and our information respecting its ornithic chiefly rests on the catalogue given by Sykes many years ago,<sup>1</sup> which only contains about 150 species of Land-birds, of which about 105 belong to genera common to the Himalayan and Malayan Subregions, 27 to Himalayan but not Malayan genera, 30 to genera having Ethiopian or Palearctic affinity, and the rest to widely-ranging genera or to genera peculiar to the Indian Subregion.

The avifauna of Southern India seems to be small relatively to the extent and variety of the country, and most of its peculiar species are said to have a considerable range of latitude, though some, which are restricted to the highest hills, are only found to the southward of lat. 12° N., where several mountain-ranges reach the height of 8000 feet. No single comprehensive list of the Birds of this part of India seems lately to have been put together, and Mr Elwes gives us no statistics as the result of his investigations whereby we may compare its ornithic products with those of other districts.

Ceylon has profited by the residence of several competent naturalists—especially Mr Layard and Mr Holdsworth, and taking also its isolation into account, we are in a position to speak of this island with greater certainty than of the preceding portions of the Subregion. The latter of these gentlemen gives a list<sup>2</sup> numbering 323 species, of which 224 are Land-birds, and an analysis shows that, though 37 species are peculiar, only 4 belong to genera not found in Southern India, 22 belong to genera inhabiting the Himalaya but not the Malayan Subregion, and only 6 to Malayan but not Himalayan genera, while 14 are members of genera only found in India.

(3.) *The Malayan Subregion* is the last of which we have to treat, and we have already hinted that it possibly has a connection with the Indian through the Nicobar Islands, but of course the most intimate communication between the two exists on the mainland. The birds of its continental portion, the Malay Peninsula, have never formed the subject of a separate memoir, and to compile a complete list of them at present is a task which a more competent author has found impossible. Stoliczka has given us a catalogue<sup>3</sup> of 95 species obtained in the Wellesley Province, lying opposite to Penang, and numerous species have been constantly described by various authors as coming from Malacca or Singapore, which in most cases probably means that the specimens have been purchased at one of those places. To enter into any details with respect to the Malay Peninsula, therefore, would here be impossible, but the case is different as regards the islands which form the greater part of the Subregion.

The Philippines, for more than a century, have supplied European ornithologists with materials of study, yet it is little more than ten years ago that any attempt to compile a complete list of their Birds was made, and that list, by Dr von Martens,<sup>4</sup> was manifestly imperfect. It is only since the present article was begun that a satisfactory account of their avifauna has appeared. This is the work of Lord Walden,<sup>5</sup> and we here avail ourselves of the results which he has so ably set forth. He enumerates 219 species, of which 150 are Land-birds; but in consequence

of the caution he has exercised, it is most probable that this number is really too small. Of these, 106 species are peculiar to the archipelago—96 of them being Land-birds. There is no species, he remarks, which is common to the Philippines and the neighbouring island of Celebes which does not also possess a more extended range, and there is only one genus—*Prioniturus*, a very singular form of *Pittacus*—common to both and yet found nowhere else. The genera peculiar to the group are 11 in number—*Pseudolalage* belonging to *Campophagida*, *Zoocopus* to *Muscicapida*, *Rhabdornis* to *Corthida*, *Sarcope* to *Sturnida*, *Penelopides* to *Bucconida*, *Dasylophus* and *Lepidogrammus* to *Cuculida*, *Pseudoplys* to *Strigida*, *Phaboteron* and *Ptilocolpa* to *Columbida*, and *Amasornis* to *Rallida*. There is also only 1 species common to one of the Philippines—the island of Negros—and to one other island. This is *Xantholama rosea*, which is also found in Java, and seems to be the representative of the widely-spread *X. hamatocephala*, which ranges over India, Malacca, and Sumatra, but is not found either in Java or Negros. It will thus be seen that the amount of peculiarity exhibited by the avifauna of the Philippines is very great, but it must be observed that hardly anything is as yet known of Palawan or the Sooloo cluster—islands which connect the Philippines with Borneo.

Borneo is the next island to which our attention should be directed, and this magnificent country, large enough as Mr Wallace has remarked for the whole of the United Kingdom to be set down in its midst and hidden, has lately had its avifauna carefully investigated by Dr Salvadori, the result of whose labours was published in 1874.<sup>6</sup> The following may be given as a summary of them. There are 392 species, of which 325 are Land-birds, 27 belonging to the Order *Accipitres*, 4 to *Pittacia*, 99 to *Picaria*, 172 to *Passeres*, 14 to *Columba*, and 9 to *Gallina*. Yet there are only 3 unquestionably peculiar genera—*Pityriasis*, a most singular form, doubtfully referred to *Laniida*, *Schwameria* belonging to *Muscicapida*, and *Heterococeus* to *Cuculida*. There are 58 or 59 peculiar species, all but 1 Land-birds, and at least 25, or perhaps as many as 32, which have no representatives elsewhere. Of Land-birds Borneo has, in common with Malacca and Sumatra, 226 species; in common with Java, 149; with the Philippines, 25; with the Indian Subregion, 53; with China, 72; and with Celebes, 28. A species of *Megapodius* (*M. cumingi*) is found in Borneo and also in the Philippines,<sup>7</sup> and its presence in both, like that of a member of the same genus in the Nicobars already noticed, is a very remarkable fact.

The comparatively little-known island of Banca, lying between Borneo and Sumatra, produces 2 peculiar species of *Pittida*, the one representing a species which inhabits the whole Subregion and extends to China and Siam, the other allied to two species, the first ranging from Nepal to Malacca, and the second inhabiting the Philippines, Borneo, and Sumatra.<sup>8</sup>

Sumatra must be considered next, or perhaps it ought to have been taken after Malacca, from which it is divided by so narrow a channel. The greater part of this island, its northern half especially, is unknown, and not more than 240 species can be assigned to it, of which about 20 appear to be peculiar. Its avifauna is much allied to that

<sup>1</sup> *Annali del Museo Civico di Storia Naturale di Genova*, v. pp. 1-430.

<sup>2</sup> A reputed fourth, *Anas*, referred to *Ardeinax*; is suspected to be founded on a manufactured specimen! *Loblophiasis*, since established by Mr Sharpe (*Ann. and Mag. Nat. Hist. Ser. 4*, xiv. p. 378), and belonging to *Phasianida*, probably makes another.

<sup>3</sup> Mr Sharpe, however, considers the species distinct (*Proc. Zool. Soc.* 1875, p. 111).

<sup>4</sup> But on this point compare Mr Hume's remark (*Stray Feathers*, II. p. 475).

<sup>1</sup> *Proc. Zool. Soc.* 1832, pp. 77, 149

<sup>2</sup> *Op. cit.*, 1872, pp. 404-483.

<sup>3</sup> *Journ. As. Soc. Beng.* 1870, pp. 277-334. This, however, must not be read without referring to Lord Walden's remarks on it (*Ibid.*, 1871, pp. 168-177).

<sup>4</sup> *Journal für Ornithologie*, 1866, pp. 5-31

<sup>5</sup> *Transactions of the Zoological Society*, ix. pp. 125-252.

both of Malacca and of Borneo, but it seems to have much less peculiarity than the latter's.

We then have Java, the best-explored, the most thickly peopled, and, proportionately to its fauna, the most peculiar, perhaps, of the Indo-Malay Islands. Here we find about 270 species of Land-birds, of which about 45 are peculiar—most of them being from the mountains in the western part of the island. The reappearance in Java of several Burmese species, as *Cryptorhina varians*, *Picus analis*, *Pavo muticus*, and others, which do not occur in the Malay Peninsula south of Penang, is very remarkable.

Of Bali, so interesting as the southern outpost of the Region, we only know from Mr Wallace that he saw there several Birds highly characteristic of Javan ornithology, and whether the island has any peculiar species nowhere appears. We are then brought to the brink of that remarkable strait through which runs "Wallace's Line," and crossing it find ourselves at once in the Australian Region, with which we began this protracted dissertation.

It is, of course, much to be regretted that at present our information does not allow of our treating all the Six Zoological Regions of the globe on a uniform plan, or of dealing equally with their several component portions. That this will be possible in a few years, as materials are accumulated, none can doubt; but as yet we are far from the attainment of so desirable an end, and must be content to make the most of what we have. Want of space, also, has hindered the proper consideration here of many points that fully deserve notice, and especially the negative characteristics of the different Regions—often quite as important as those which are positive. Of the imperfections of the preceding sketch no one can be more painfully aware than its author, but its very imperfections may serve a useful purpose in drawing attention to the districts about which least is known. Yet it would be affectation for him not to believe that it has some actual merit, but that merit is greatly if not chiefly due to the kindness of Mr Wallace, who, in the manner already stated, has allowed his forthcoming work to be laid under contribution, though in several respects its conclusions are not here adopted. That work, when published, will unquestionably form a foundation on which a noble superstructure will ultimately be erected, but it were vain to anticipate the ends which such a building will one day serve, and it would be beyond our scope to enter into any theoretical disquisition on the deductions which follow from the facts here advanced.

#### MIGRATION.

Most strangely and unaccountably confounded by many writers with the subject of Distribution is that of Migration. True it is that owing to the vast powers of locomotion possessed by nearly all Birds, we have individuals belonging in the main to certain groups, but by no means always confined to them, straying from their proper quarters and occurring in places far removed, not only from the land of their birth, but from the country whither they are ordinarily bound in their journeys, to reach which is the object wherefore such journeys are undertaken. It may be that in some measure this erraticism is governed by fixed laws, and indeed indication is not wanting that such laws exist, though as yet we know much too little to lay them down with any approach to confidence. But it is obvious on reflection that, granting the existence of most rigorous laws of this kind—determining the flight of every winged vagabond—they must be very different from those which are obeyed by Birds commonly called "Migratory," and migrating year after year according to a more or less

fixed rule from one locality to another with the seasons as they roll. The former laws would seem to be created or controlled by purely external circumstances, which if they possess any periodicity at all possess a periodicity of cycles, and are most likely dependent in the main on cycles of the weather, but on this point observation has not yet supplied us with the means of avoiding speculation. We may indeed say almost without much risk of error that so many individuals of a foreign species—whether North-American or Asiatic—will occur in Great Britain so many times in the course of a term of years; but, though we may safely predict that if they appear at all they will do so at a certain season, it is impossible to make a forecast as to the year in which an example will turn up, or whether in one year some half-dozen may or may not occur. The matter thus becomes a matter of averages, and like all such is open to the influence of many perturbants, not that such may not well be subject to some law of which we are ignorant. Besides this, the average is hard to strike, depending as it must on the existence of favourably-placed and watchful observers. Moreover if we consider that the number of competent observers, though possibly greater in England than anywhere else in the world, has been at all times small, it is not surprising that little has been effected towards the compassing of any definite notion on this head. At present we can but attribute the appearance of foreign stragglers on our shores, and no doubt the same may be said of other countries, to the influence of storms which have driven the wanderers from their course, and though other more remote causes may possibly be assigned, there seems to be none but this on which we can safely rely. Consequently until the periodicity of storms is brought within our knowledge we must be content to abide in our ignorance of the laws which govern the appearance of the strangers. Still confining our remarks to the British Islands, the effect of these laws is in some degree constant. Singular as it may appear, the greatest number of North-American Birds—and especially of the *Limicola*, or Shore-birds, which are recorded as having occurred in this country have been met with in the eastern part of England or Scotland. There are two ways of accounting for this fact, the first of which is the unfortunate scarcity of observing naturalists in Ireland and on its western coast especially, and this is by no means to be overlooked; but it may be remarked that in no part of the United Kingdom is the profession of the gunner more enthusiastically followed than in the sister island, and the men who pursue that vocation are all alive to the mercantile value of any strange bird which may fall in their way. Of course they have no means of knowing what it is, yet as their spoils are sent for sale to the nearest market, it cannot but happen that if many examples of North-American species were procured by them, some proportion of these would find their way to the notice of the amateur naturalist and by him be recorded in the public prints.<sup>1</sup> Now, as compared with Great Britain, this so rarely occurs in Ireland that it is by no means unfair to draw the inference that Transatlantic Birds are there far less frequently met with. The second mode of accounting for the fact above stated is that the majority of North-American Birds which occasionally visit Europe are of species which breed in somewhat high northern latitudes. On their way thence to their winter-quarters, some are driven out to sea by violent westerly gales—the strongest winds, be it remembered, that prevail

<sup>1</sup> It seems also not unlikely that the very scarcity of rare birds in Ireland is one reason why there are so few ornithologists in that country, for here it is not uncommon for a man to have his attention first called to zoology by meeting with some strange animal—be it beast, bird, beetle, or butterfly, and for such a man afterwards to become no mean field-naturalist.

in the North Atlantic, and thus strike the coast of Norway.<sup>1</sup> In that country observers may be said to be practically absent, and fowling as a rule unknown. Such storm-beaten wanderers there consort with the allied species to be found at that season in abundance on its shores and in their company pursue the same southerly course. With them they cross to the east of Great Britain, and once arrived here are speedily picked out and secured by the practised gunner. But should they even escape his notice, they with their comrades follow the shore-line, where they obtain the best supply of food, until passing round the south coast they find themselves at the western extremity of England—the district of the Land's End, in which, next to Norfolk and Suffolk, the greatest number of these Transatlantic stragglers have been obtained. This suggestion may serve to shew what most likely goes on in other parts of the world, though the materials for establishing its general truth are not forthcoming.

But returning to the subject of Migration proper, distinguished as it ought to be from that of the more or less accidental occurrence of stray visitors from afar, we have here more than enough to excite our wonder, and indeed are brought face to face with perhaps the greatest mystery which the whole animal kingdom presents—a mystery which attracted the attention of the earliest writers, and can in its chief part be no more explained by the modern man of science than by the simple-minded savage or the poet or prophet of antiquity. Some facts are almost universally known and have been the theme of comment in all ages and in all lands. The Hawk that stretches her wings toward the south is as familiar to the latest Nile-boat traveller or dweller on the Bosphorus as of old to the author of the book of Job. The autumnal thronging of myriads of Waterfowl by the rivers of Asia is witnessed by the modern sportsman as it was of old by Homer. Anacreon welcomed the returning Swallow, in numbers which his imitators of the colder north, to whom the associations connected with it are doubly strong, have tried in vain to excel. The Indian of the Fur-Countries in forming his rude calendar names the recurring moons after the Birds-of-passage whose arrival is coincident with their changes. But there is no need to multiply instances. The flow and ebb of the mighty feathered wave has been sung by poets and reasoned of by philosophers, has given rise to proverbs and entered into popular superstitions, and yet we must say of it still that our "ignorance is immense."

On one point and one only in connection with this subject can we boast ourselves to be clearly wiser than our ancestors. Some of them fully believed that the seasonal disappearance of the Swallow, the Nightingale, the Cuckoo, and the Corncrake was due to hibernation, while others indeed doubted whether or not this was the true explanation of the fact. It is not so long since this belief and these doubts were in vogue, but now assuredly they have no hold upon the mind of any one capable of appreciating evidence, and this absurd fancy being exploded need not again trouble us.

In considering the phenomena of Migration it will be best first to take the facts, and then try to account for their cause or causes. That a very large number of Birds all over the world change their abode according to the season is well known, and we find that in almost all countries there are some species which arrive in spring, remain to breed, and depart in autumn; others which arrive in autumn, stop for the winter, and depart in spring; and others again—and these are strictly speaking the "Birds of Passage"—which shew themselves but twice a

year, passing through the country without staying long in it, and their transient visits take place about spring and autumn. People who have given but little thought to the subject are apt to suppose that these migrants, which may thus easily be classed in three categories, are acted upon by influences of different kinds, whereas very little reflection will show that all are really affected by the same impulse, whatever that may be, and that the at first sight dissimilar nature of their movements is in truth almost uniform. The species which resort to this and to other temperate countries in winter are simply those which have their breeding-quarters much nearer the poles, and in returning to them on the approach of spring are but doing exactly as do those species which, having their winter-abode nearer the equator, come to us with the spring. The Birds-of-passage proper, like our winter-visitors have their breeding-quarters nearer the poles, but, like our summer-visitors, they seek their winter-abode nearer the equator, and thus perform a somewhat longer migration. So far there is no difficulty and no hypothesis—the bringing together of these three apparently different categories is the result of simple observation.

This however is not the only fact which is evident on the most cursory examination. To take the birds of the British Islands as an example (though exactly similar cases are presented in other countries) we find that while there are some species, such as the Swallow or the Fieldfare, of which every individual disappears at one period of the year or another, there are other species, such as the Pied Wagtail or the Woodcock, of which only the majority of individuals vanish—a few being always present<sup>2</sup>—and these species form the so-called "Partial Migrants." If we extend our view and look to birds on the continent of Europe, we find that many species are there notoriously migrant which are not generally suspected to be so in this country—such as the Song-Thrush and the Redbreast, both of which species closer observation has proved to be with us subject to the migratory impulse. In respect of the former it is known that towards the end of summer or in autumn our native Song-Thrushes receive a considerable accession in numbers from the birds which arrive from the north, though the immigration is by no means so well marked as it is in Belgium, France, or Germany, where the arrival of the strangers sets all the fowling to work, and the beginning of the *Chasse aux Grives* or *Drosselzug* is regarded in many places nearly as the Twelfth of August or the First of September is with us. In most localities in Britain the new comers depart after a short sojourn, and are accompanied by so many of the home-bred birds that in some parts of the island it may be safely declared that not a single Song-Thrush can be found from the end of November to the end of January, while in others examples can always be seen. Much the same may be said of the Redbreast. Undeniably resident as a species, attentive scrutiny will reveal the fact that its numbers are subject to very considerable variation according to the season of the year. At no time do our Redbreasts collect in bands, but towards the end of summer they may be seen in the south of England successively passing onward, the travellers being mostly if not wholly young birds of the year; and so the great majority disappear, departing it may be safely presumed for more southern countries, since a few weeks later the markets of most towns first in France and then in Italy are well supplied with this species. But the migratory influence affects, though in a less degree, many if not most of the Redbreasts that remain with us. Content during the autumn to occupy their usual haunts,

<sup>1</sup> Prof. Baird's remarks on this subject are much to the point (*Am. Journ. Sc.*, ser. 2, xii. pp. 344, 345).

<sup>2</sup> Whether these few be not migrants from another district is a point that would require further consideration.

the first sharp frost has a decided effect upon their distribution, and a heavy fall of snow drives them towards the homesteads for the larger supply of food they find there, while should severe and long-continued hard weather follow even these birds vanish, leaving only the few which have become almost domesticated.

These two species have been here chosen as illustrative cases because they are at once plentiful and familiar, and want of space only forbids us from citing others, but we shall find on inquiry that there is scarcely a Bird of either the Palearctic or Nearctic Region, whose habits are at all well known, of which much the same may not be said, and hence we are led to the conclusion that every Bird of the northern hemisphere is to a greater or less degree migratory in some part or other of its range. Such a conclusion brings us to a still more general inference—namely that Migration, instead of being the exceptional characteristic it used formerly to be thought, may really be almost universal, and though the lack of observations in other, and especially tropical, countries does not allow us to declare that such is the case, it seems very probable to be so. Before proceeding however to any further conclusions it is necessary to examine another class of facts which may possibly throw some light on the matter.

It must be within the experience of every one who has ever been a birds'-nesting boy that the most sedentary of Birds year after year occupy the same quarters in the breeding season.<sup>1</sup> In some instances this may be ascribed, it is true, to the old haunt affording the sole or the most convenient site for the nest in the neighbourhood, but in so many instances such is not the case that we are led to believe in the existence of a real partiality, while there are quite enough exceptions to show that a choice is frequently exercised. The same may equally be said of the most migrant of Birds, and perhaps the strongest instance that has ever come to the knowledge of the writer refers to one of the latter. A pair of Stone-Curlews (*Edicnemus crepitans*)—a very migratory species, affecting almost exclusively the most open country—were in the habit of breeding for many years on the same spot though its character had undergone a complete change. It had been part of an extensive and barren rabbit-warren, and was become the centre of a large and flourishing plantation.

With these two sets of facts before us we may begin to try and account for the cause or causes of Migration. In some cases want of food would seem to be enough, as it is undoubtedly the most obvious cause that presents itself to our mind.<sup>2</sup> The need which all animals have of finding for themselves proper and sufficient sustenance is all-powerful, and the difficulties they have to encounter in

obtaining it are so great that none can wonder that those which possess the power of removing themselves from a place of scarcity should avail themselves of it, while it is unquestionable that no Class of animals has this facility in a greater degree than Birds.<sup>3</sup> Even among many of those species which we commonly speak of as sedentary, it is only the adults which maintain their ground throughout the year. It has long been known that Birds-of-prey customarily drive away their offspring from their own haunts so soon as the young are able to shift for themselves. The reason generally, and no doubt truly, given for this behaviour, which at first sight appears so unnatural, is the impossibility of both parents and progeny getting a livelihood in the same vicinity. The practice, however, is not limited to the Birds-of-prey alone, but is much more universal. We find it to obtain with the Redbreast, and if we watch our feathered neighbours closely we shall perceive that most of them indulge in it. The period of expulsion, it is true, is in some Birds deferred from the end of summer or the autumn, in which it is usually performed, until the following spring, when indeed from the maturity of the young it must be regarded as much in the light of a voluntary secession on their part as in that of an act of parental compulsion, but the effect is ultimately the same. These cases, however, which make certainly the exception rather than the rule, we can account for in another manner. It is to be observed that they are confined to species having a peculiar mode of life, the individuals associating in family-parties to form small bands. The members of the Titmouse-family (*Paridae*) offer a good instance of this peculiarity, but it requires no very abstruse reflection to perceive that the adoption of this habit is one eminently conducive to the easy attainment of their food, which is collected, as it were, in particular spots often far apart, but where it does occur occurring plentifully. Thus a single Titmouse searching alone might hunt for a whole day without meeting with a sufficiency, while if a dozen are united by the same motive it is hardly possible for the place in which the food is lodged to escape their detection, and when discovered a few call-notes from the lucky finder are enough to assemble the whole company to share the feast. It is impossible to watch a band of any species of Titmouse, even for a few minutes, without arriving at this conclusion. One tree after another is visited by the active little rovers, and its branches examined: if nothing be forthcoming away goes the explorer to the next that presents itself, merely giving utterance to the usual twitter that serves to keep the body together. But if the object of search be found, another kind of chirp is emitted, and the next moment the several members of the band are flitting in succession to the tree and eagerly engaged with the spoil.<sup>4</sup>

The mode in which the want of sustenance produces Migration may best be illustrated by confining ourselves to the unquestionably migrant Birds of our own northern hemisphere. As food grows scarce towards the end of summer in the most northern limits of the range of a species, the individuals affected thereby seek it elsewhere. Thus doing, they press upon the haunt of other individuals: these in like manner upon that of yet others, and so on,

<sup>1</sup> Two remarkable instances of this persistency may be noticed. The nest of a Falcon (*Falco peregrinus*) on Avasaxa—a hill in Finland somewhat celebrated as one of the most southern points whence the midnight sun may be seen—is mentioned by the French astronomer Manpertuis as having been observed by him in the year 1786. In 1796 it was rediscovered by Skjöldebrand and Akerbl. In 1858 Wolley found it tenanted, and from enquiries he made of the neighbours it was evident that such had yearly been the case so far as any one could remember, and so it was in 1855 as the writer can testify. In 1779 according to one account, in 1785 according to another, a pair of the Blue Titmouse (*Parus caeruleus*) built their nest in a large earthenware bottle placed in the branches of a tree in a garden at Oxbridge near Stockton-on-Tees. With two exceptions only, this bottle, or a second which has lately been placed close to it, has been tenanted by a pair of birds of this species from the year in which it was first occupied until 1873, when the writer saw it.—See Yarrell's *British Birds*, 4th ed. i. pp. 53, 496.

<sup>2</sup> Far more so than variation of the temperature, though in popular belief that probably holds the first place. But Birds generally, as compared with other Vertebrates, are but slightly affected by extremes of heat or cold, and indeed (so far as we can judge) by most climatic influences, provided only their supply of food is not affected thereby.—*Cf.* Max Schmidt, *Zoolog. Garten*, 1866, pp. 330-340.)

<sup>3</sup> The only animals which approach Birds in the extent and character of their migrations are Fishes, of which there is no need here to say anything.

<sup>4</sup> The case is altogether different with those species which in winter form themselves into large flocks, as most of the Finches (*Fringillidae*) and Buntings (*Emberizidae*). The discoverer of a favourite morsel perhaps by his actions betrays what he has obtained, and accordingly his fellows may repair to the place, but it is without invitation on his part, and the only particular bond of union not entirely selfish which keeps them together is the cry of alarm with which a stranger is greeted.

until the movement which began in the far north is communicated to the individuals occupying the extreme southern range of the species at that season; though, but for such an intrusion, these last might be content to stay some time longer in the enjoyment of their existing quarters.

This seems satisfactorily to explain the southward movement of all migrating Birds in the northern hemisphere; but when we consider the return movement which takes place some six months later, doubt may be entertained whether scarcity of food can be assigned as its sole or sufficient cause, and perhaps it would be safest not to come to any decision on this point. On one side it may be urged that the more equatorial regions which in winter are crowded with emigrants from the north, though well fitted for the resort of so great a population at that season are deficient in certain necessities for the nursery. Nor does it seem too violent an assumption to suppose that even if such necessities are not absolutely wanting, yet that the regions in question would not supply sufficient food for both parents and offspring—the latter being at the lowest computation, twice as numerous as the former—unless the numbers of both were diminished by the casualties of travel.<sup>1</sup> But on the other hand we must remember what has above been advanced in regard to the pertinacity with which Birds return to their accustomed breeding-places, and the force of this passionate fondness for the old home cannot but be taken into account, even if we do not allow that in it lies the whole stimulus to undertake the perilous voyage.

Mr Wallace in some remarks on the subject (*Nature*, x. p. 459) ingeniously suggests the manner in which the habit of Migration has come to be adopted:<sup>2</sup>—

“It appears to me probable that here, as in so many other cases, ‘survival of the fittest’ will be found to have had a powerful influence. Let us suppose that in any species of migratory bird, breeding can as a rule be only safely accomplished in a given area; and further, that during a great part of the rest of the year sufficient food cannot be obtained in that area. It will follow that those birds which do not leave the breeding area at the proper season will suffer, and ultimately become extinct; which will also be the fate of those which do not leave the feeding area at the proper time. Now, if we suppose that the two areas were (for some remote ancestor of the existing species) coincident, but by geological and climatic changes gradually diverged from each other, we can easily understand how the habit of incipient and partial migration at the proper seasons would at last become hereditary, and so fixed as to be what we term an instinct. It will probably be found, that every gradation still exists in various parts of the world, from a complete coincidence to a complete separation of the breeding and the subsistence areas; and when the natural history of a sufficient number of species is thoroughly worked out, we may find every link between species which never leave a restricted area in which they breed and live the whole year round, to those other cases in which the two areas are absolutely separated.”

A few more particulars respecting Migration are all that can here be given, and it is doubtful whether much can be built upon them. It has now been ascertained by repeated observation that in the spring-movement of most species of the northern hemisphere the cock-birds are always in the van of the advancing army, and that they appear some days, or perhaps weeks, before the hens. It is not difficult to imagine that, in the course of a journey

<sup>1</sup> If the relative proportion of land to water in the Southern Hemisphere were at all such as it is in the Northern, we should no doubt find the birds of southern continents beginning to press upon the tropical and equatorial regions of the globe at the season when they were thronged with the emigrants from the north, and in such a case it would be only reasonable that the latter should be acted upon by the force of the former, according to the explanation given of the southward movement of northern migrants. But, though we know almost nothing of the migration of birds of the other hemisphere, yet, when we regard the comparative deficiency of land in southern latitudes all round the world, it is obvious that the feathered population of such as now-a-days exists can exert but little influence, and its effects may be practically disregarded.

<sup>2</sup> In principle Captain Hutton had already foreshadowed the same theory.—(*Trans. New Zeal. Inst.* 1872, p. 236.)

prolonged throughout some 50° or 60° of latitude, the stronger individuals should outstrip the weaker by a very perceptible distance, and it can hardly be doubted that in most species the males are stouter, as they are bigger than the females. Some observers assert that the same thing takes place in the return-journey in autumn, but on this point others are not so sure, which is not surprising when we consider that the majority of observations have been made towards what is the northern limit of the range of the *Passeres*, to which the remark is especially applicable—in the British Islands, France, North Germany, and the Russian Empire—for it is plain that at the beginning of the journey any inequality in the speed of travelling will not have become so very manifest. There is also another matter to be noticed. It has been suspected that where there is any difference in the size of birds of the same species, particularly in the dimensions of their wings, the individuals that perform the most extensive journeys are naturally those with the longest and broadest *remiges*, and in support of this view it certainly appears that in some of the smaller migrants—such as the Wheatear (*Saxicola oenanthe*) and Willow-Wren (*Phylloscopus trochilus*)—the examples which reach the extreme north of Europe and there pass the summer possess greater mechanical powers of flight than those of the same species which stop short on the shores of the Mediterranean. It may perhaps be also inferred, though precise evidence is wanting, that these same individuals push further to the southward in winter than do those which are less favoured in this respect. It is pretty nearly certain that such is the case with some species, and it may well be so with individuals. Canon Tristram has remarked (*Ibis*, 1866, p. 77) that, in many genera of Birds, “those species which have the most extended northerly have also the most extended southerly range; and that those which resort to the highest latitudes for nidification also pass further than others to the southward in winter,” fortifying his opinion by examples adduced from the genera *Turdus*, *Fringilla*, *Cypselus*, and *Turtur*. But supposing this to be true for many Birds, it may fairly be doubted whether it is so for all, and whether in some species certain individuals do not always occupy the most northern portion of the range and others always keep to the most southern, no matter what the season of the year may be, or over what countries the range may extend. On this point therefore it will be advisable to await further investigation.

For many years past a large number of persons in different countries have occupied and amused themselves by carefully registering the dates on which various migratory Birds first make their appearance, and certain publications abound with the records so compiled.<sup>3</sup> Some of the observers have been men of high scientific repute, others of less note but of not inferior capabilities for this especial object. Still it does not seem that they have been able to determine what connection, if any, exists between the arrival of birds and the state of the weather. This is not very wonderful, for the movements of the migrants, if governed at all by meteorological forces, must be influenced by their action in the places whence the travellers have come, and therefore to establish any direct relation of cause and effect corresponding observations ought equally to be made in such places, which has seldom been done.<sup>4</sup>

<sup>3</sup> These are far too numerous to mention here. Perhaps the most remarkable series of them is that carried on from 1786 to 1810 and again from 1836 to 1874 by four generations of the Marsham family at Stratton-Strawless and Blippon near Norwich, of which an account is given by Mr Southwall (*Trans. Norw. and Norw. Nat. Soc.* ii. p. 31).

<sup>4</sup> To a limited extent it must be admitted that the popular belief as to certain Birds being the harbingers of severe weather is justifiable. Cold comes from the north, and when it is accompanied, as is most gene-

As a rule it would seem as though Birds were not dependent on the weather to any great degree. Occasionally the return of the Swallow or the Nightingale may be somewhat delayed, but most Sea-fowls may be trusted, it is said, as the almanack itself. Were they satellites revolving around this earth, their arrival could hardly be more surely calculated by an astronomer. Foul weather or fair, heat or cold, the Puffins (*Fratercula arctica*) repair to some of their stations punctually on a given day as if their movements were regulated by clock-work. Whether they have come from far or from near we know not, but other Birds certainly come from a great distance, and yet make their appearance with scarcely less exactness. Nor is the regularity with which certain species disappear much inferior; every observer knows how abundant the Swift (*Cypselus apus*) is up to the time of its leaving its summer-home—in most parts of England, the first days of August—and how rarely it is seen after that time is past.

It must be allowed, however, that, with few exceptions, the mass of statistics above spoken of has never been worked up and digested so as to allow proper inferences to be made from them, and therefore it would be premature to say that little would come of it, but the result of those few exceptions is not very encouraging. Some twenty years ago Dr von Middendorff carefully collated the records of the arrival of migratory Birds throughout the Russian Empire, but the insight into the question afforded by his published labours<sup>1</sup> is not very great. His chief object has been to trace what he has termed the *isopteses* (*ivos = aqualis, tririvus = advolatus*) or the lines of simultaneous arrival, and in the case of 7 species<sup>2</sup> these are laid down on the maps which accompany his treatise. The lines are found by taking the average date of arrival of each species at each place in the Russian dominions where observations have been regularly made, and connecting those places where the dates are the same for each species by lines on the map. The curves thus drawn indicate the inequality of progress made by the species in different longitudes, and assuming that the advance is directly across the isoptesimal lines, or rather the belts defined by each pair of them, the whole course of the migration is thus most accurately made known. In the case of his seven sample species the maps show their progressive advance at intervals of a few days, and the issue of the whole investigation, according to him (*op. cit.* p. 8) proves that in the middle of Siberia the general direction of the usual migrants is almost due north, in the east of Siberia from south-east to north-west, and in European Russia from south-west to north-east. Thus nearly all the migrants of the Russian Empire tend to converge upon the most northern part of the continent, the Taimyr Peninsula, but it is almost needless to say that few of them reach anything like so far, since the country in those high latitudes is utterly unfit to support the majority. With the exception of some details, which, though possessing a certain special interest, need not here be mentioned, this treatise fails to show more; for the fact that there are places that notwithstanding their higher latitude are reached by Birds on their spring-migrations sooner than others in a lower latitude was already known.

The routes followed by migratory Birds, so far as our information at present extends, has been the subject of a

very exhaustive memoir by Herr Palmén,<sup>3</sup> but it would be impossible within the limits of the present article to do more than mention his results concisely. He enters very fully into this part of the enquiry and lays down with much apparent probability the chief roads taken by the most migratory Birds of the Palearctic Region in their return autumnal journey, further asserting that in the spaces between these lines of flight such birds do not usually occur. These main routes are, he states, nine in number. The first (A—to use his notation), leaving the Siberian shores of the Polar Sea, Nova Zembla, and the North of Russia, passes down the west coast of Norway to the North Sea and the British Islands. The second (B), proceeding from Spitzbergen and the adjoining islands, follows much the same course, but is prolonged past France, Spain, and Portugal to the west coast of Africa. The third (C) starts from Northern Russia, and, threading the White Sea, and the great Lakes of Onega and Ladoga, skirts the Gulf of Finland and the southern part of the Baltic to Holstein and so to Holland, where it divides—one branch uniting with the second main route (B), while the other, running up the valley of the Rhine and crossing to that of the Rhone, splits up on reaching the Mediterranean, where one path passes down the western coast of Italy and Sicily, a second takes the line by Corsica and Sardinia, and a third follows the south coast of France and eastern coast of Spain—all three paths ending in North Africa. The fourth (D), fifth (E), and sixth (F) main routes depart from the extreme north of Siberia. The fourth (D) ascending the river Ob, branches out near Tobolok—one track, diverging to the Volga, descends that river and so passes to the Sea of Azov, the Black Sea, and thence, by the Bosphorus and Ægean, to Egypt; another track makes for the Caspian by way of the Ural River and so leads to the Persian Gulf, while two more are lost sight of on the steppe. The fifth (E) mounts the Jennesee to Lake Baikal and so passes into Mongolia. The sixth (F) ascends the Lena and striking the Upper Amoor reaches the Sea of Japan, where it coalesces with the seventh (G) and eighth (O) which run from the eastern portion of Siberia and Kamchatka. Besides these the ninth (X) starting from Greenland and Iceland passes by the Færoes to the British Islands and so joining the second (B) and third (C) runs down the French coast. These being the main routes it must be added that, in Herr Palmén's opinion and that of many others, nearly all river-courses form minor routes.<sup>4</sup>

But lay down the paths of migratory Birds, observe their comings and goings, or strive to account for the impulse which urges them forward as we will, there still remains for consideration the most marvellous thing of all—How do the birds find their way so unerringly from such immense distances! This seems to be by far the most inexplicable part of the matter. Year after year the migra-

<sup>1</sup> *On Fyglarne Aflyttingsvege* (Helsingfors: 1874). In this and the work of Dr von Middendorff, already cited, reference is made to almost every important publication on the subject of Migration, which renders a notice of its very extensive literature needless here, and a pretty full bibliographical list is given in Prof. Giebel's *Thesaurus Ornithologicus* (l. pp. 146-155). Yet mention may be made of Prof. Schlegel's *Over het trekken des Vogels* (Harlem: 1828), Mr Hodgson's "On the Migration of the *Nastores* and *Grallatores* as observed at Kathmandu" in *Asiatic Researches* (xviii. pp. 122-128), and M. Marcel de Serran's *Des courses des Migrations des Animaux et particulièrement des Oiseaux et des Poissons* (Harlem: 1843). This last though one of the largest publications on the subject is one of the least satisfactory. Prof. Baird's excellent treatise *On the Distribution and Migration of North American Birds* has been before adverted to.

<sup>4</sup> In giving this abstract the present writer wishes to state that he does not thereby express his agreement with all that it contains. Herr Palmén's views deserve the fullest attention from the truly scientific spirit in which they are put forward, but some of the details on which they are founded seem to require correction.

rally the case, by heavy falls of snow, such Birds are of course driven southward to seek their living. But as often as not the Birds arrive with the kind of weather they are commonly held to prognosticate, while sometimes this does not follow their appearance.

<sup>2</sup> *Die Isoptesen Russlands. Grundlagen zur Erforschung der Zugellen und Zugrichtungen der Vogel Russlands.* St Petersburg: 1855.

<sup>3</sup> *Hirundo rustica, Molocilla alba, Alouca arvensis, Oriolus galbula, Cusculus canorus, Ciconia alba, and Grus communis.*

tory Wagtail will build her nest in the accustomed spot, and year after year the migratory Cuckoo will deposit her eggs in that nest, and yet in each interval of time the former may have passed some months on the shores of the Mediterranean, and the latter, absent for a still longer period, may have wandered into the heart of Africa.<sup>1</sup> The writer cannot offer an approach to the solution of this mystery. There was a time when he had hopes that what is called the "homing" faculty in Pigeons might furnish a clue, but Mr Tegetmeier and all the best authorities on that subject declare that a knowledge of landmarks obtained by sight, and sight only, is the sense which directs these Birds, while sight alone can hardly be regarded as affording much aid to Birds—and there is reason to think that there are several such—which at one stretch transport themselves across the breadth of Europe, or even traverse more than a thousand miles of open ocean, to say nothing of those—and of them there are certainly many—which perform their migrations by night. That particular form of Bluethroat which yearly repairs to breed upon the mooses of the Subalpine and Northern parts of Scandinavia (*Cyanocula suecica*) is hardly ever seen in Europe south of the Baltic.<sup>2</sup> Throughout Germany it may be said to be quite unknown, being replaced by a conspicuously different form (*C. leucocyanus*), and as it is a Bird in which the collectors of that country, a numerous and well-instructed body have long taken great interest, we are in a position to declare that it is not known to stop in its transit from its winter haunts, which we know to be Egypt and the valley of the Upper Nile, to its breeding-quarters. Other instances, though none so crucial as this, could be cited from among European Birds were there room here for them. In New Zealand there are two Cuckoos which are annual visitors: one, a species of *Chrysococcyx*, is supposed to come from Australia, the other, *Eudynamis taitensis* is widely spread throughout Polynesia, yet both these birds yearly make two voyages over the enormous waste of waters that surrounds the country to which they resort to breed. But space would utterly fail us were we to attempt to recount all the examples of these wonderful flights. Yet it seems impossible that the sense of sight should be the faculty whereby they are so guided to their destination, any more than in the case of those which travel in the dark.

Dr von Middendorff (*op. cit.* p. 9), from the conclusions he has drawn, as before mentioned, as to the spring-movement of all birds in the Russian Empire being towards the Taimyr Peninsula, the seat of one of the magnetic poles, has suggested that the migrating Bird is always aware (he does not sufficiently explain by what means) of the situation of this point, and thus knows how to steer its course. Not only is this hypothesis supported by any considerations known to the writer, but it is not at all borne out by the observed facts of Migration in North America, where Birds as has been shewn by Professor Baird (*op. cit.* p. 347) do not migrate in the direction of the magnetic pole.

Other authors there are who rely on what they call "instinct" as an explanation of this wonderful faculty. This with them is simply a way of evading the difficulty before us, if it does not indeed remove the question altogether from the domain of scientific inquiry. Rejecting such a mode of treatment, Herr Palmén meets it in a much

fairer spirit. He asserts (*op. cit.* p. 195) that migrants are led by the older and stronger individuals among them, and, observing that most of those which stray from their right course are yearlings that have never before taken the journey, he ascribes the due performance of the flight to "experience." But, granting the undisputed truth of his observation, his assertion seems to be only partially proved. That the birds which lead the flock are the strongest is on all accounts most likely, but what is there to show that these are also the oldest of the concourse? Besides this, there are many Birds which cannot be said to migrate in flocks. While Swallows, to take a sufficiently evident example, conspicuously congregate in vast flocks and so leave our shores in large companies, the majority of our summer-visitors slip away almost unobserved, each apparently without concert with others. It is also pretty nearly certain that the same species of Bird does not migrate in the same manner at all times. When Skylarks arrive on our north-eastern coast in autumn they come fitting over in a constant, straggling stream, not in compact flocks; yet a little later these same birds collect in enormous assemblages which prosecute their voyage in company. It is indeed possible that each bird of the stream intentionally follows that which goes before it, though in a long sea-passage it must be hard to keep the precursor in sight, and it may perhaps be granted that the leader of the whole is a bird of experience. But then we must consider not these cases only, but also those of Birds which do not migrate in company, and we must also have regard to what is implied in the word "experience." Here it can only signify the result of knowledge acquired on former occasions, and obtained by sight. Now it was stated by Temminck<sup>3</sup> many years ago, and so far as would appear the statement has not been invalidated, that among migrants the young and the old always journey apart and most generally by different routes. The former can have no "experience," and yet the greater number of them safely arrive at the haven where they would be. The sense of sight, essential to a knowledge of landmarks, as we have above attempted to demonstrate, is utterly insufficient to account for the success that attends Birds which travel by night, or in a single flight span oceans or continents. Yet without it the idea of "experience" cannot be substantiated. We may admit that inherited but unconscious experience, which is really all that can be meant by instinct, is a factor in the whole matter—certainly, as Mr Wallace seems to have proved, in originating the migratory impulse, but yet every aspect of the question is fraught with difficulty, and we must leave to time the discovery of this mystery of mysteries.

There yet remain a few words to be said on what may be termed Exceptional Migration, that is when from some cause or other the ordinary practice is broken through. This differs from the chance occurrence of the waifs and strays with which this section of the article began in that the Birds subject to it keep in a great measure their customary habit of migrating, and yet are compelled to indulge it in an irregular, or perhaps an altogether novel, manner, though they are not entirely the sport of circumstances. The erratic movements of the various species of Crossbill (*Loxia*) and some allied forms afford perhaps the best-known examples. In England no one can say in what part of the country or at what season of the year he may not fall in with a company of the Common Crossbill (*L. curvirostris*), and the like may be said of many other lands. The food of these Birds consists mainly of the seeds of oonifers, and as its supply in any one locality is intermittent or precarious, we may not unreasonably guess that

<sup>1</sup> Absolute proof of the identity of the particular birds is of course wanting, but if that objection be raised the circumstance becomes still more puzzling, for then we have to account for some mode of communicating precise information by one bird to another.

<sup>2</sup> It has occurred indeed as a straggler in about a dozen instances in England, and it arrives twice a year in greater or less numbers in Hallgöle, as reported by the ever-watchful observer on that island, Mr Gäcke, to whom ornithologists are so deeply indebted for his long-continued and intelligent scrutiny of the extraordinary number of wandering birds which alight there.

<sup>3</sup> *Manual of Ornithologie*, iii. Introd. p. xliii. note.

they shift from place to place in its quest, and may thus find an easy way of accounting for their uncertain appearance. The great band of Nutcrackers (*Nucifraga caryocatactes*) which in the autumn of 1844 pervaded Western and Central Europe<sup>1</sup> may also have been actuated by the same motive, but we can hardly explain the roaming of all other Birds so plausibly. The inroads of the Waxwing (*Ampelis garrulus*) have been the subject of interest for more than 300 years, and by persons prone to superstitious auguries were regarded as the forerunners of dire calamity. Sometimes years have passed without its being seen at all in Central, Western, or Southern Europe, and then perhaps for two or three seasons in succession vast flocks have suddenly appeared. Later observation has shown that this species is as inconstant in the choice of its summer-as of its winter-quarters, and though the cause of the irregularity may possibly be of much the same kind as that just suggested in the case of the Crossbill, the truth awaits further investigation.<sup>2</sup> One of the most extraordinary events known to ornithologists is the irruption into Europe in 1863 of Pallas's Sand-Grouse (*Syrhaptes paradoxus*). Of this Bird, hitherto known only as an inhabitant of the Tartar steppes, a single specimen was obtained at Sarepta on the Volga in the winter of 1848. In May 1859 a pair is said to have been killed in the Government of Vilna on the western borders of the Russian Empire, and a few weeks later five examples were procured, and a few others seen, in Western Europe—one in Jutland, one in Holland, two in England, and one in Wales. In 1860 another was obtained at Sarepta; but in May and June 1863 a horde computed to consist of at least 700 individuals overran Europe—reaching Sweden, Norway, the Færoes, and Ireland in the north-west, and in the south extending to Sicily and almost to the frontiers of Spain. On the sandhills of Jutland and Holland some of these birds bred, but war was too successfully waged against the nomades to allow of their establishing themselves, and a few survivors only were left to fall to the gun in the course of the following winter and spring.<sup>3</sup> In the summer of 1872, another visitation to Great Britain was reported, but if it really took place it must have been that of a very small number of birds, and it was not observed on the Continent. Speculation has amused itself by assigning causes to these movements but the real reason remains in doubt.

We cannot quit the subject of Migration, however, without referring to the wonderful assemblages of Birds which have in various places been time and again noticed by night. Towards the close of summer, in dark, cloudy, and still weather, it not infrequently happens that a vast and, to judge from their cries, heterogeneous concourse of Birds may be heard hovering over our large towns. The practical ornithologist will recognize the notes of Plover, Sandpiper, Tern, and Gull, now faint with distance and then apparently close overhead, while occasionally the stroke of a wing may catch his ear, but nothing is visible in the surrounding gloom. Sometimes but a few fitful wails are heard, of which only an expert listener will know the meaning. At others the continuous Babel of sounds will ensure the attention of the most incurious. It is supposed that these noises proceed from migrating birds, which, having lost their way, are attracted by the glare of the street-lamps, but far too little has been observed to remove the obscurity that in a double sense surrounds them and to enable us to come to any definite conclusion. It must be added also that such a concourse has been noticed where the fascina-

tion of light did not exist, for Lord Lilford has recorded<sup>4</sup> how that once at Corfu he was startled by an uproar as if all the feathered inhabitants of the great Acherusian Marsh had met in conflict overhead, but he could form no conception of what birds produced the greater part of it.

#### SONG.

Leaving then the subject of Migration, the next important part of the economy of Birds to be considered is perhaps their Song—a word, however, in a treatise of this kind to be used in a general sense, and not limited to the vocal sounds uttered by not more than a moiety of the feathered races which charm us by the strains they pour from their vibrating throat,—strains indeed denied by the scientific musician to come under cognizance as appertaining to his art, but strains which in all countries and in all ages have conveyed a feeling of true pleasure to the human hearer, and strains of which by common consent the Nightingale is the consummate master. It is necessary in a philosophical spirit to regard every sound made by a Bird under the all-powerful influence of love or lust as a "Song." It seems impossible to draw any but an arbitrary line between the deep booming of the Emu, the harsh cry of the Guillemot (which, when proceeding from a hundred or a thousand throats, strikes the distant ear in a confused murmur like the roar of a tumultuous crowd), the plaintive wail of the Plover, the melodious whistle of the Widgeon, "the Cock's shrill clarion," the scream of the Eagle, the hoot of the Owl, the solemn chime of the Bell-bird, the whip-cracking of the Manakin, the Chaffinch's joyous burst, or the hoarse croak of the Raven, on the one hand, and the bleating of the Snipe<sup>5</sup> or the drumming of the Ruffed Grouse, on the other. Innumerable are the forms which such utterances take. In many birds the sounds are due to a combination of vocal and instrumental powers, or, as in the cases last mentioned, to the latter only. But, however produced—and of the machinery whereby they are accomplished there is not room here to speak—all have the same cause and the same effect. The former has been already indicated, and the latter is its consummation. Almost contemporaneously with the hatching of the Nightingale's brood, the song of the sire is hushed, and the notes to which we have for weeks hearkened with rapt admiration are changed to a guttural croak, expressive of alarm and anxiety, inspiring a sentiment of the most opposite character. No greater contrast can be imagined, and no instance can be cited which more completely points out the purpose which "Song" fulfils in the economy of the bird, for if the Nightingale's nest at this early time be destroyed or its contents removed, the cock speedily recovers his voice, and his favourite haunts again resound to his bewitching strains. For them his mate is content again to undergo the wearisome round of nest-building and incubation. But should some days elapse before disaster befalls their callow care, his constitution undergoes a change and no second attempt to rear a family is made. It would seem as though a mild temperature, and the abundance of food by which it is generally accompanied, prompt the physiological alteration which inspires the males of most birds to indulge in the "Song" peculiar to them. Thus after the annual moult is accomplished, and this is believed to be the most critical epoch in the life of any bird, cock Thrushes, Skylarks, and others begin to sing, not indeed with the jubilant voice of spring but in an

<sup>1</sup> Bull. de l'Acad. de Bruxelles, xi. p. 298.

<sup>2</sup> Cf. Yarell, *Birds*, ed. 4, l. pp. 524-532.

<sup>3</sup> *Ibid.*, 1864, pp. 185-222. A few additional particulars which have since become known to the writer are inserted above.

<sup>4</sup> *Ibid.*, 1865, p. 176.

<sup>5</sup> The true cause of this sound has been much discussed, but Herr Meves's explanation (*Proc. Zool. Soc.* 1858, p. 302), based on experiment, seems to be correct, though it is far from being generally accepted.



uncertain cadence which is quickly silenced by the super-vention of cold weather. Yet some birds we have which, except during the season of moult, hard frost, and time of snow, sing almost all the year round. Of these the Red-breast and the Wren are familiar examples, and the Chiff-chaff repeats its two-noted cry, almost to weariness, during the whole period of its residence in this country.<sup>1</sup>

Akin to the "Song" of Birds, and undoubtedly proceeding from the same cause, are the peculiar gestures which the males of many perform under the influence of the approaching season of pairing, but these again are far too numerous here to describe with particularity. It must suffice to mention a few cases. The Ruff on his hillock in a marsh holds a war-dance. The Snipe and some of his allies mount aloft and wildly execute unlooked-for evolutions almost in the clouds. The Woodcock and many of the Goatsuckers beat evening after evening the same aerial path with its sudden and sharp turnings. The Ring-Dove rises above the neighbouring trees and then with motionless wings slides down to the leafy retreat they afford. The Capercally and Blackcock, perched on a commanding eminence, throw themselves into postures that defy the skill of the caricaturist—other species of the Grouse-tribe assume the strangest attitudes and run in circles till the turf is worn bare. The Peacock in pride spreads his train so as to shew how nearly akin are the majestic and the ludicrous. The Bower-bird, not content with his own splendour, builds an arcade, decked with bright feathers and shining shells, through and around which he paces with his gay companions. The Larks and Pipits never deliver their song so well as when seeking the upper air. Rooks rise one after the other to a great height and, turning on their back, wantonly precipitate themselves many yards towards the ground, while the solemn Raven does not scorn a similar feat, and, with the tenderest of croaks, glides supinely alongside or in front of his mate.<sup>2</sup>

#### NIDIFICATION.

Following or coincident with the actions just named, and countless more besides, comes the real work of the breeding-season, to which they are but the prelude or the accompaniment. Nidification is with most birds the beginning of this business; but with many it is a labour that is scamped if not shirked. Some of the Auk tribe place their single egg on a bare ledge of rock, where its peculiar conical shape is but a precarious safeguard when rocked by the wind or stirred by the thronging crowd of its parents' fellows. The Stone-Curlew and the Goatsucker deposit their eggs without the slightest preparation of the soil on which they rest; yet this is not done at haphazard, for no birds can be more constant in selecting, almost to an inch, the very same spot which year after year they choose for their precarient cradle. In marked contrast to such artless care stand the wonderful structures which others, such as the Tailor-bird, the Bottle-Titmouse, or the Fantail-Warbler build for the comfort or safety of their young. But every

variety of disposition may be found in the Class. The Apteryx seems to entrust its abnormally big egg to an excavation among the roots of a tree-fern; while a band of female Ostriches scrape holes in the desert-sand and therein promiscuously dropping their eggs cover them with earth and leave the task of incubation to the male, who discharges the duty thus imposed upon him by night only, and trusts by day to the sun's rays for keeping up the needful, fostering warmth. The Megapodes raise a huge hotbed of dead leaves wherein they deposit their eggs and the young are hatched without further care on the part of either parent. Some of the Grebes and Rails seem to avail themselves in a less degree of the heat generated by vegetable decay, and dragging from the bottom or sides of the waters they frequent fragments of aquatic plants form of them a rude half-floating mass which is piled on some growing water-weed—but these birds do not spurn the duties of maternity. Many of the Gulls, Sandpipers, and Plovers lay their eggs in a shallow pit which they hollow out in the soil, and then as incubation proceeds add thereto a low breastwork of haulm. The Ringed Plover commonly places its eggs on a shingle, which they so much resemble in colour, but when breeding on grassy uplands it paves the nest-hole with small stones. Pigeons mostly make an artless platform of sticks so loosely laid together that their pearly treasures may be perceived from beneath by the inquisitive observer. The Magpie, as though self-conscious that its own thieving habits may be imitated by its neighbours, surrounds its nest with a hedge of thorns. Very many birds of almost every group bore holes in some sandy cliff, and at the end of their tunnel deposit their eggs with or without bedding. Such bedding, too, is very various in character; thus, while the Shelduck and the Sand-Martin supply the softest of materials, the one of down from her own body, the other of feathers collected by dint of diligent search,—the Kingfisher forms a couch of the undigested spiny fish-bones which she ejects in pellets from her own stomach. Other birds, as the Woodpeckers, hew holes in living trees, even when the timber is of considerable hardness, and therein establish their nursery. Some of the Swifts secrete from their salivary glands a fluid which rapidly hardens as it dries on exposure to the air into a substance resembling isinglass, and thus furnish the "edible birds' nests" that are the delight of Chinese epicures. In the architecture of nearly all the Passerine birds, too, some salivary secretion seems to play an important part. By its aid they are enabled to moisten and bend the otherwise refractory twigs and straws and glue them to their place. Spiders' webs also are employed with great advantage for the purpose last mentioned, but perhaps chiefly to attach fragments of moss and lichen so as to render the whole structure less obvious to the eye of the spoiler. The Tailor-bird deliberately spins a thread of cotton and therewith stitches together the edges of a pair of leaves to make a receptacle for its nest. Beautiful too is the felt fabricated of fur or hairs by the various species of Titmouse, while many birds ingeniously weave into a compact mass both animal and vegetable fibres, forming an admirable non-conducting medium which guards the eggs from the extremes of temperature outside. Such a structure may be open and cup-shaped, supported from below as that of the Chaffinch and Goldfinch, domed like that of the Wren and Bottle-Titmouse, slung hammock-wise as in the case of the Golden-crested Wren and the Orioles, or suspended by a single cord as with certain Grosbeaks and Humming-birds. Under such circumstances it is even sometimes needful to balance the nest lest the weight of the growing young should destroy the equipoise and, precipitating them on the ground, dash the hopes of the parents, and compensation in such cases is applied by loading the opposite

<sup>1</sup> A curious question, which has as yet attracted but little attention, is whether the notes of the same species of Bird are in all countries alike. From his own observation the writer is inclined to think that it is not, and that there may exist "dialects," so to speak, of the song. (*Cf. Gloger, Jour. für Orn.* 1859, p. 398.)

<sup>2</sup> No comprehensive account of the Song of Birds seems ever to have been written. The following may be cited as the principal treatises on the subject:—Barrington, *Phil. Trans.* 1778, pp. 249–291; Kennedy, *N. Abhandl. Natur. Acad. (Phil. Abhandl.)* 1797, p. 169; Blackwall, *Mém. Lit. and Phil. Soc. Mançh.* 1824, pp. 289–323; Savart, (*Forsberg's*) *Notizen u. s. w.*, 1826, pp. 1–10, 20–25; Brehm and Hansmann, *Neumann's*, 1855, pp. 54–59, 96–101, 181–195, and *Journ. für Orn.* 1855, pp. 348–351, 1856, pp. 250–255. The notes of many of our common Birds are musically expressed by Mr Harting, *Birds of Middlesex* (London: 1866).

side of the structure with lumps of earth. Certain Warblers (*Aedon* and *Thamnobia*) for some unascertained reason invariably lay a piece of snake's slough in their nests—to repel, it has been suggested, marauding lizards who may thereby fear the neighbourhood of a deadly enemy. The clay-built edifices of the Swallow and Martin are known to everybody, and the Nuthatch plasters up the gaping mouth of its nest-hole till only a postern large enough for entrance and exit, but easy of defence, is left. In South America we have a family of birds (*Furnariidae*) which construct on the branching roots of the mangrove globular ovens, so to speak, of mud, wherein the eggs are laid and the young hatched. The Flamingo erects in the marshes it frequents a mound of earth some two feet in height, with a cavity atop, on which the hen, having oviposited, sits astride with dangling legs, and in that remarkable attitude is said to perform the duty of incubation. The females of the Hornbills, and perhaps of the Hoopoes, submit to incarceration during this interesting period, the males immuring them by a barrier of mud, leaving only a small window to admit air and food, which latter is assiduously brought to the prisoner.

But though in a general way the dictates of hereditary instinct are rigidly observed by birds, in many species a remarkable degree of elasticity is exhibited or the rule of habit is rudely broken. Thus the noble Falcon, whose ordinary eyry is on the beetling cliff, will for the convenience of procuring prey condescend to lay its eggs on the ground in a marsh, or appropriate the nest of some other bird in a tree. The Golden Eagle, too, remarkably adapts itself to circumstances, now rearing its young on a precipitous ledge, now on the arm of an ancient monarch of the forest and again on a treeless plain, making a humble home amid grass and herbage. Herons also shew the same versatility and will breed according to circumstances in an open fen, on sea-banks or (as is most usual) on lofty trees. Such changes are easy to understand. The instinct of finding food for the family is predominant, and where most food is there will the feeders be gathered together. This explains, in all likelihood, the associated bands of Ospreys or Fish-Hawks, which in North America breed (or used to breed) in large companies where sustenance is plentiful, though in the Old World the same species brooks not the society of aught but its mate. Birds there are of eminently social predilections. In Europe, excepting Sea-fowls—whose congregations are universal and known to all—we have perhaps but the Heron, the Fieldfare, and the Rook, which habitually flock during the breeding-season; but in other parts of the world many birds unite in company at that time, and in none possibly is this habit so strongly developed as in the Anis of the Neotropical Region, the Republican Swallow of North America, and the Sociable Grosbeak of South Africa, which last joins nest to nest until the tree is said to break down under the accumulated weight of the common edifice.<sup>1</sup>

In the strongest contrast to these amiable qualities is the parasitic nature of the Cuckows of the Old World and the Cow-birds of the New, but this peculiarity of theirs is so well known that to dwell upon it would be needless. Enough to say that the egg of the parasite is introduced

<sup>1</sup> There are not many works on nidification, for "Oology" or the study of nests has hardly been deemed a distinct branch of the science. A good deal of instructive matter (not altogether free from error) will be found in Beattie's *Architecture of Birds* (London: 1881), and there is Mr Wallace's most interesting dissertation, "A Theory of Birds' Nests," originally published in the *Journal of Travel and Natural History* (1868, p. 78), and reprinted in his *Contributions to the Theory of Natural Selection* (London: 1876). Mr Andrew Murray's and the Duke of Argyll's remarks on this essay are contained in the same volume of the *Journal* named (pp. 187 and 276).

into the nest of the dupe, and after the necessary incubation by the fond fool of a foster-mother the interloper successfully counterfeits the heirs, who perish miserably, victims of his superior strength. The whole process has been often watched, but the reflective naturalist will pause to ask how such a state of things came about, and there is not much to satisfy his enquiry. Certain it is that some birds whether by mistake or stupidity do not unfrequently lay their eggs in the nests of others. It is within the knowledge of many that Pheasants' eggs and Partridges' eggs are often laid in the same nest, and it is within the knowledge of the writer that Gulls' eggs have been found in the nests of Eider-Ducks, and *vice versa*; that a Redstart and a Field Flycatcher will lay their eggs in the same convenient hole—the forest being rather deficient in such accommodation; that an Owl and a Duck will resort to the same nest-box, set up by a scheming woodsman for his own advantage; and that the Starling, which constantly dispossesses the Green Woodpecker, sometimes discovers that the rightful heir of the domicile has to be brought up by the intruding tenant. In all such cases it is not possible to say which species is so constituted as to obtain the mastery, but it is not difficult to conceive that in the course of ages that which was driven from its home might thrive through the fostering of its young by the invader, and thus the abandonment of domestic habits and duties might become a direct gain to the evicted householder. This much granted, all the rest will follow easily enough, but it must be confessed that this is only a presumption, though a presumption which seems plausible if not likely.

#### EGGS.

The pains bestowed by such Birds (incomparably the most numerous of the Class), as build elaborate nests and the devices employed by those that, not doing so, display no little skill in providing for the preservation of their produce, invite some attention to the eggs which they lay. This attention will perhaps be more cheerfully given when we think how many naturalists, not merely ornithologists, have been first directed to the study of the animal kingdom by the spoils they have won in their early days of birds' nesting. With some such men the fascination of this boyish pursuit has maintained its full force even in old age—a fact not so much to be wondered at when it is considered that hardly any branch of the practical study of Natural History brings the enquirer so closely in contact with many of its secrets. It is therefore eminently pardonable for the victims of this devotion to dignify their passion by the learned name of "Oology," and to bespeak for it the claims of a science. Yet the present writer—once an ardent follower of the practice of birds' nesting, and still on occasion warming to its pleasures—must confess to a certain amount of disappointment as to the benefits it was expected to confer on Systematic Ornithology, though he yields to none in his high estimate of its utility in acquainting the learner with the most interesting details of bird-life—without a knowledge of which nearly all systematic study is but work that may as well be done in a library, a museum, or a dissecting-room, and is incapable of conveying information to the learner concerning the why and the wherefore of such or such modifications and adaptations of structure. To some—and especially to those who are only anatomists—this statement may seem preposterous, but it is in truth no such thing. What engineer can be said to understand his business if he knows not the purpose to which the machines he makes are to be applied and is unacquainted with their mode of working? We may investigate thoroughly the organs of any animal, we may trace them from the earliest moment in which they become defined, and

watch them as they develop to maturity, we may comprehend the way in which every part of a complicated structure is successively built up, but if we take not the trouble to know their effect on the economy of the creature we as naturalists have done but half our task and abandon our labour when the fulness of reward is coming upon us. The field-naturalist, properly instructed, crowns the work of the comparative anatomist and the physiologist, though without the necessary education he is little more than an empiric, even should he possess the trained cunning of the savage on whose knowledge of the habits of wild animals depends his chance of procuring a meal.

Perhaps the greatest scientific triumph of oologists lies in their having fully appreciated the intimate alliance of the *Limicola* (the great group of Snipes and Plovers) with the *Gavia* (the Gulls, Terns, and other birds more distantly connected with them) before it was recognized by any professed taxonomist,—L'Herminier, whose researches have been much overlooked, excepted; though to such an one was given the privilege of placing that affinity beyond cavil (Huxley, *Proc. Zool. Soc.* 1867, pp. 426, 456-458; cf. *Ibis*, 1868, p. 92). In like manner it is believed that oologists first saw the need of separating from the true *Passeres* several groups of birds that had for many years been unhesitatingly associated with that very uniform assemblage. Diffidence as to their own capacity for meddling with matters of systematic arrangement may possibly have been the cause which deterred the men who were content to brood over birds' eggs from sooner asserting the validity of the views they held. Following the example furnished by the objects of their study, they seem to have chiefly sought to hide their offspring from the curious eye—and if such was their design it must be allowed to have been admirably successful. In enthusiastic zeal for the prosecution of their favourite researches, however, they have never yielded to, if they have not surpassed, any other class of naturalists. If a storm-swept island, only to be reached at the risk of life, held out the hope of some oological novelty there was the egg-collector (Faber, *Ibis*, xx. pp. 633-688; Proctor, *Naturalist*, 1838, pp. 411, 412). Did another treasure demand his traversing a burning desert (Tristram, *Ibis*, 1859, p. 79) or sojourning for several winters within the wildest wastes of the Arctic Circle (Wolley, *Ibis*, 1859, pp. 69-76; 1861, pp. 92-106; Kennicott, *Rep. Smithsonian Inst.* 1862, pp. 39, 40), he endured the necessary hardships to accomplish his end, and the possession to him of an empty shell of carbonate of lime,<sup>1</sup> stained or not (as the case might be) by a secretion of the villous membrane of the parent's uterus, was to him a sufficient reward. Taxonomers, however, have probably been right in not attaching too great an importance to such systematic characters as can be deduced from the eggs of birds, but it would have been better had they not insisted so strongly as they have done on the infallibility of one or another set of characters, chosen by themselves. Oology taken alone proves to be a guide as misleading as any other arbitrary method of classification, but combined with the evidence afforded by due study of other particularities, whether superficial or deep-seated, it can scarcely fail in time to conduct us to an ornithological arrangement as nearly true to Nature as we may expect to achieve.

The first man of science who seems to have given any special thought to oology, was the celebrated Sir Thomas Brown, of Norwich, who already in 1681, when visited by John Evelyn (from whose diary we learn the fact), had assigned a place in his cabinet of rarities to a collection of birds' eggs. The next we hear of is that Count of Marsigli

who early in the eighteenth century explored, chiefly for this kind of investigation, the valley of the Danube—a region at that time, it is almost unnecessary to remark, utterly unknown to naturalists. But there is no need to catalogue the worthies of this study. As they approach our own day their number becomes far too great to tell, and if very recently it has seemed to dwindle the reason is probably at hand in the reflection that most of the greatest prizes have been won, while those that remain to reward the aspiring appear to be just now from one cause or another almost out of reach. Perhaps at the present time the Birds-of-Paradise and their allies form the only group of any recognized distinctiveness and extent of whose eggs we know absolutely nothing—though there are important isolated forms, such as *Asirichia*, *Heterolocha*, and others, concerning the eggs as well as the breeding habits of which our ignorance is absolute, and the species of many families that have hitherto defied the zeal of oologists are very numerous. These last, however, though including some common and some not very uncommon British birds, possess in a general way comparatively little interest, since, the eggs of their nearest allies being well known, we cannot expect much to follow from the discovery of the recluses, and it is only to the impassioned collector that the obtaining of such desiderata will afford much satisfaction.

The first thing which strikes the eye of one who beholds a large collection of egg-shells is the varied hues of the specimens. Hardly a shade known to the colourist is not exhibited by one or more, and some of these tints have their beauty enhanced by the glossy surface on which they are displayed, by their harmonious blending, or by the pleasing contrast of the pigments which form markings as often of the most irregular as of regular shape. But it would seem as though such markings, which a very small amount of observation will shew to have been deposited on the shell a short time before its exclusion, are primarily and normally circular, for hardly any egg that bears markings at all does not exhibit some spots of that form, but that in the progress of the eggs through that part of the oviduct in which the colouring matter is laid on many of them become smeared, blotched, or protracted in some particular direction. The circular spots thus betoken the deposition of the pigment while the egg is at rest, the blurred markings show its deposition while the egg is in motion, and this motion would seem often to be at once onward and rotatory, as indicated by the spiral markings not uncommonly observable in the eggs of some Birds-of-prey and others—the larger end of the egg (when the ends differ in form) making way for the smaller.<sup>2</sup> At the same time the eggs of a great number of birds bear, beside these last and superimposed markings, more deeply-seated stains, generally of a paler and often of an altogether different hue, and these are evidently due to some earlier dyeing process. The peculiar tint of the ground-colour, though commonly superficial, if not actually congenial with the formation of the shell, would appear to be suffused soon after. The depth of colouring whether original or supervening is obviously dependent in a great measure on the constitution or bodily condition of the parent. If a bird, bearing in its oviduct a fully-formed egg, be captured, that egg will speedily be laid under any circumstances of inconvenience to which its producer shall be subjected, but such an egg is usually deficient in coloration—fright and

<sup>2</sup> That the larger end is protruded first was found on actual experiment by Mr Bartlett, Superintendent of the Gardens of the Zoological Society, to be the case commonly, but as an accident the position may be sometimes reversed, and this will most likely account for the occasional deposition of markings on the smaller instead of the larger end as not unfrequently shown in eggs of the Sparrow-hawk (*Accipiter nisus*). The head of the chick is always formed at the larger end.

<sup>1</sup> A small proportion of carbonate of magnesia and phosphate of lime and magnesia also enters into its composition.

captivity having arrested the natural secretions. In like manner over excitement or debility of the organs, the consequence of ill health, give rise to much and often very curious abnormality. It is commonly believed that the older a bird is the more intensely coloured will be its eggs, and to some extent this belief appears to be true. Certain *Falconidae*, which ordinarily lay very brilliantly-tinted eggs, and are therefore good tests, seem when young unable to secrete so much colouring-matter as they do when older, and season after season the dyes become deeper, but there is reason to think that when the bird has attained its full vigour improvement stops, and a few years later the intensity of hue begins to decline. It would be well if we had more evidence, however, in support of this opinion, which is chiefly based on a series of eggs of one species—the Golden Eagle (*Aquila chrysaetos*), in the writer's possession, among which are some believed on good grounds to have been the produce in the course of about twelve years of one and the same female. The amount of colouring-matter secreted and deposited seems notwithstanding to be generally a pretty constant quantity—allowance being made for individual constitution; but it often happens—especially in birds that lay only two eggs—that nearly all the dye will be deposited on one of these, leaving the other colourless; it seems, however, to be a matter of inconstancy which of the two is first developed. Thus of two pairs of Golden Eagles' eggs also in the possession of the writer, one specimen of each pair is nearly white while the other is deeply coloured, and it is known that in one case the white egg was laid first and in the other the coloured one. When birds lay many mottled, and a fortiori plain, eggs, there is generally less difference in their colouring, and though no two can hardly ever be said to be really alike, yet the family resemblance between them all is obvious to the practised eye. It would seem however to be a peculiarity with some species—and the Tree-Sparrow (*Passer montanus*) which lays five or six eggs may be taken as a striking example—that one egg should always differ remarkably from the rest of the clutch. In addition to what has been said above as to the deposition of colour in circular spots indicating a pause in the progress of the egg through one part of the oviduct, it may be observed that the cessation of motion at that time is equally shown by the clearly defined hair-lines or vermiculations seen in many eggs, and in none more commonly met with than in those of the Buntings (*Emberisidae*). Such markings must not only have been deposited while the egg was at rest, but it must have remained motionless until the pigment was completely set, or blurred instead of sharp edges would have been the result.<sup>1</sup>

The composition of this pigment has long excited much curiosity, and it has been commonly and rather crudely ascribed to secretions of the blood or bile,<sup>2</sup> but very recently unexpected light has been shed upon the subject by the researches of Mr Sorby (*Proc. Eool. Soc.* 1875, p. 351), who, using the method of spectrum-analysis, has now ascertained the existence of seven well-marked substances in the colouring-matter of eggs, to the admixture of which in certain proportions all their tints are due. These he names

Oorhodeine, Oocyan, Banded Oocyan, Yellow Ooxanthine, Rufous Ooxanthine, a substance, giving narrow absorption-bands in the red, the true colour of which he has not yet been able to decide, and lastly Lichenoxanthine. It would be out of place here to particularize their chemical properties, and it is enough to say that they are closely connected either with hæmoglobin or bile-pigments, and in many respects resemble the latter more than do any other group of colouring-matters, but do not actually agree with them. The first is perhaps the most important of all the seven, because it occurs more or less in the shells of so great a number of eggs that its entire absence is exceptional, and it is of a very permanent character, its general colour being of a peculiar brown-red. The second and third seem when pure to be of a very fine blue, but the spectrum of the former shows no detached bands, while that of the latter has a well-marked detached absorbent-band near the red end, though the two are closely related since they yield the same product when oxidized. The fourth and fifth substances supply a bright yellow or reddish-yellow hue, and the former is particularly characteristic of eggs of the Emu (*Dromæus*), giving rise when mixed with oocyan to the fine malachite-green which they possess, while the latter has only been met with in those of the Tinamou (*Tinamidae*), in which it should be mentioned that oorhodeine has not been found, or perhaps in those of a Cassowary (*Casuarinus*), and when mixed with oocyan produces a peculiar lead-colour. The sixth substance, as before stated, has not yet been sufficiently determined, but it would seem in combination with others to give them an abnormally browner tint; and the seventh appears to be identical with one which occurs in greater or less amount in almost all classes of plants, but is more especially abundant in and characteristic of lichens and fungi. There is a possibility however of this last being in part if not wholly due to the growth of minute fungi, though Mr Sorby believes that some such substance really is a normal constituent of the shell of eggs having a peculiar brick-red colour. That gentleman is further inclined to think that oorhodeine is in some way or other closely related to cruentine, being probably derived from the red colouring-matter of the blood by some unknown process of secretion, and likewise that there is some chemical relation between the oocyans and the bile.

The grain of the egg-shell offers characters that deserve far more consideration than they have received until lately, when the attention of Herr von Nathusius having been directed to the subject by some investigations carried on by Dr Landois<sup>3</sup> and Herr Rudolf Blasius,<sup>4</sup> he has brought out a series of remarkable papers<sup>5</sup> in which he has arrived at the conclusion that a well-defined type of shell-structure belongs to certain families of birds, and is easily recognised under the microscope. In some cases, as in the eggs of certain Swans and Geese (*Cygnus olor* and *C. musicus*, *Anser cinereus* and *A. segetum*) even specific differences are apparent. The bearing of these researches on classification generally is of considerable importance and must be taken into account by all future taxonomers. Here we cannot enter into details, it must suffice to remark that the grain of the shell is sometimes so fine that the surface is glossy, and this is the case with a large number of *Picariae*, where it is also quite colourless and the contents of their eggs seen through the semi-transparent shell give an

<sup>1</sup> The principal oological works with coloured figures are the following:—Thienemann, *Fortpflanzungsgeschichte der gesammten Vögel* (4to, Leipzig: 1845); Leffèvre, *Atlas des œufs des oiseaux d'Europe* (8vo, Paris: 1845); Hewitson, *Coloured Illustrations of the Eggs of British Birds* (8vo, Ed. 3, London: 1856); Brewer, *North American Oology* (4to, Washington: 1859); Taczanowski, *Oologia Ptaków Polskich* (8vo, Warszawa: 1862); Bäckler, *Die Eier der Europäischen Vögel* (fol. Leipzig: 1863); Waller, *Ootheca Wollegams* (8vo, London: 1864)—some of which have never been completed; but a great number of rare eggs are also figured in various journals, as the *Proceedings of the Ecological Society*, *Nannamnia*, the *Journal für Ornithologie*, and *The Ibis*.  
<sup>2</sup> Cf. Wilke, *Nannamnia*, 1856, pp. 288–297, and C. Leconte, *Revue et Mémoires de Zoologie*, 1860, pp. 190–205.

<sup>3</sup> *Zeitschr. für wissenschaft. Zoologie*, xv. pp. 1–31.

<sup>4</sup> *Op. cit.* xvii. pp. 480–524.

<sup>5</sup> *Op. cit.* xviii. pp. 19–21, pp. 225–270, xix. pp. 322–343, xx. pp. 106–120, xxi. pp. 520–525. A summary of these will be found in *Journal für Ornith.* 1871, pp. 241–260, and the subject has been continued in the same periodical for 1872, pp. 331–352, and 1874, pp. 1–23.

opalescence of great beauty; but among the Tinamous (*Tinamida*) colour is invariably present and their opaque eggs present the appearance of more or less globular balls of highly-burnished metal or glazed porcelain. Most birds lay eggs with a smooth shell, such as nearly all the *Gavia*, *Limicola*, and *Passeres*, and in some groups, as with the normal *Gallina*, this seems to be enamelled or much polished, but it is still very different from the brilliant surface of those just mentioned, and nothing like a definite line can be drawn between their structure and that in which the substance is dull and uniform, as among the *Alcida* and the *Accipitres*. In many of the *Ratites* the surface is granulated and pitted in an extraordinary manner,<sup>1</sup> and in a less degree the same feature is observable in the eggs of some other birds, as the Storks (*Ciconiida*). Many Water-fowls, and particularly the Ducks (*Anatida*), lay eggs with a greasy or oleaginous exterior, as the collector who wishes to inscribe his specimens with marks of their identity often finds to his inconvenience; but there are other eggs, as those of the Anis (*Crotophaga*), the Grebes (*Podicipedida*), and all of the *Steganopodes*, except *Phaeton*, which are more or less covered with a cretaceous film, often of considerable thickness and varied by calcareous protuberances.

In form eggs vary very much, and this is sometimes observable in examples not only of the same species but even from the same mother, yet a certain amount of resemblance is usually to be traced according to the natural group to which the parents belong. Those of the Owls (*Strigida*) and of some of the *Picaria*—especially those which lay the glossy eggs above spoken of—are often apparently spherical, though it is probable that if tested mathematically none would be found truly so—indeed it may be asserted that few eggs are strictly symmetrical, however nearly they may seem so, one side bulging out, though very slightly, more than the other. The really oval form, with which we are most familiar, needs no remark, but this is capable of infinite variety caused by the relative position and proportion of the major and minor axes. In nearly all the *Limicola* and some of the *Alcida* the egg attenuates very rapidly towards the smaller end, sometimes in a slightly convex curve, sometimes without perceptible curvature, and occasionally in a sensibly concave curve. The eggs having this pyriform shape are mostly those of birds which invariably lay four in a nest, and therein they lie with their points almost meeting in the centre and thus occupying as little space as possible and more easily covered by the brooding parent. Other eggs as those of the Sand-Grouse (*Pterodroma*) are elongated and almost cylindrical for a considerable part of their length terminating at each end obtusely, while eggs of the Grebes (*Podicipedida*) which also have both ends nearly alike but pointed, are so wide in the middle as to present a biconical appearance.<sup>2</sup>

The size of eggs is generally but not at all constantly in proportion to that of the parent. The Guillemot (*Alca trisole*) and the Raven (*Corvus corax*) are themselves of about equal size; their eggs vary as ten to one. The Snipe (*Scolopax gallinago*) and the Blackbird (*Turdus merula*) differ but slightly in weight, their eggs remarkably. The eggs of the Guillemot are as big as those of an Eagle; and those of the Snipe equal in size the eggs of a Partridge (*Perdix cinerea*). Mr Hewitson, from whom these instances

<sup>1</sup> It is curious that Ostriches' eggs from North Africa are to be readily distinguished from those from the Cape of Good Hope by their smooth ivory-like surface, without any punctures, whereas southern specimens are rough as though pock-marked (*Ibis*, 1860, p. 74), yet no difference that can be deemed specific has as yet been established between the birds of the north and of the south.

<sup>2</sup> A great deal of valuable information on this and other kindred subjects is given by Des Murs, *Traité général d'Oologie ornithologique* (Svo, Paris: 1860).

are taken, remarks:—"The reason of this great disparity is, however, obvious; the eggs of all those birds which quit the nest soon after they are hatched, and which are consequently more fully developed at their birth, are very large."<sup>3</sup> It must be added, though, that the number of eggs to be covered at one time seems also to have some relation to their size, and this offers a further explanation of the fact just mentioned with regard to the Snipe and the Partridge—the former being one of those birds which are constant in producing four, and the latter often laying as many as a dozen—for the chicks of each run as soon as they release themselves from the shell.

Incubation is performed, as is well known, by the female of nearly all Birds, but with most of the *Passeres* and many others the male seems to share her tedious duties, and among the *Ratites*, apparently without exception, the cock takes that office wholly on himself. There are a few groups or perhaps species in which the same practice is suspected to obtain—certain of the *Limicola* for instance, the Godwits (*Limosa*), the Phalaropes (*Phalaropus*), and the Dotterel (*Eudromias morinellus*)—and in these it is to be remarked that the hen is larger and more brightly coloured than her mate. Owing to the unfortunate neglect of those who have the opportunity of making the needful observations the period of Incubation has been ascertained in comparatively few birds, and it is here possible to deal with that subject only in the most vague and general language. It may be asserted that most of the smaller *Passeres* of Europe hatch their young in about thirteen days, but in a few species the term is believed to be shortened to ten or eleven days, while in the largest of that Order, the Raven, it is lengthened to some twenty-one days. This also is the period which the Barndoor-fowl ordinarily takes, but the Pheasant, though so very nearly allied, takes about twenty-eight. Most Water-birds, so far as is known, and the smaller Birds-of-prey seem to require as long a time, but in the Swan incubation is protracted to six weeks. The temperature of the air is commonly credited with having something to do either in hastening or retarding, exclusion from the egg, but to what extent, or even whether justly so or not, seems in the absence of precise experiments to be doubtful. Certain birds occasionally begin brooding as soon as the first egg is laid,<sup>4</sup> and this plan unquestionably has its advantages, since the offspring being of different ages thereby become less of a burthen on the parents which have to minister to their wants, while the fostering warmth of the earlier chicks can hardly fail to aid the development of those which are unhatched, during the absence of father and mother in search of food; but most birds, and it need scarcely be said, all those the young of which run from their birth, await the completion of the clutch before sitting is begun. The care bestowed, by almost every species, on the infant-brood, is proverbial, and there is hardly any extremity of danger which one at least of the anxious parents will not incur to ward off injury from their progeny.

#### MOULT.

The more or less protracted business of reproduction being ended there forthwith follows in the case of nearly all Birds a process of the most vital consequence to them. This is the Moulting or shedding of their old and often weather-beaten feathers to be replaced by an entirely new suit. It is probably the severest strain to which bird-life is exposed, and, to judge from its effects on our domesticated pets, produces a greater mortality than an occasional want

<sup>3</sup> Hewitson, *op. cit.* Introd. p. x.

<sup>4</sup> This seems to be very often the case with the Owls, but if the writer's observation is not mistaken the habit is not constant even with the same individual bird.

of proper or even any food does. Important however as are its bearings on every individual of the whole Class, the subject is one which has been sadly neglected by ornithological writers and, with one exception,<sup>1</sup> we are not aware of any connected series of observations on Mould within the whole range of their literature. The structure and mode of growth of feathers has been very well studied and described by several investigators, and must be especially treated in introducing the subject of Pterylography—or the disposition of the various plumed patches on the bird's body—which, having been found to be a most useful auxiliary in Classification, is deferred until that comes to be discussed under the article "ORNITHOLOGY." For the present we have briefly to consider the different phases which the process of Moulding offers.

As a general rule all Birds are subject to an annual Mould, and this as above stated, commonly begins immediately on the close of the breeding-season, but, as will be explained further on, there are some which undergo in addition a second or even a third partial change of plumage, and it is possible that there may be others still more exceptional, our information respecting these, however, is too meagre to make it worth while saying anything here about them. It must be acknowledged that with regard to the great majority of forms we can only judge by analogy, and though it may well be that some interesting deviations from the general rule exist of which we are altogether ignorant, yet when we consider that the *Ratites*, so far as observed, moult exactly in the same manner as other birds,<sup>2</sup> the uniformity of the annual change may be almost taken for granted.

It is not intended here to describe the way in which a feather dies and a new one succeeds it, nor need we compare the process of moulting with the analogous shedding of the hair in Mammals or of the skin in Reptiles. Enough for our present purpose to see that such renovation is required in Birds, which nearly all have to depend upon their quills for the means of locomotion and hence of livelihood. It is easy to understand that durable as are the flight-feathers, they do not last for ever and are besides very subject to accidental breakage, the consequence of which would be the crippling of the bird. It is obviously to provide against what in most cases would be such a disaster as this last that we find the *remiges*, or quill-feathers of the wings, to be always shed in pairs. They drop out not indeed absolutely at the same moment, though this sometimes seems to happen, but within a few days of each other, and, equilibrium being thus preserved, the power of flight is but slightly deteriorated by their temporary loss. The same may be observed in a less degree, since there is less need of regularity, with the rest of the plumage, as a little attention to any tame bird will show, and the new feathers grow at an almost equal rate. In the young of most species the original quills are not shed during the first year, nor in the young of many does there seem to be an entire moult during that time, but in the typical *Gallina*, which are able to fly at a very early age, often before they are one-third grown, the original quills, being proportioned to the duties required of them, are shed before the bird has attained its full size and are succeeded by others that serve it when it has reached maturity. In the Duck-tribe (*Anatida*), however, we have a very singular exception to what has been above stated. Most of these birds shed their quill-feathers all at once, and become absolutely incapable of

flight for a season,<sup>3</sup> during which time they generally seek the shelter of thick, aquatic herbage, and it is further to be particularly remarked that the males of most of two sections of the family (*Anatina* and *Fuliginina*) at the same period lose the brilliantly-coloured plumage which commonly distinguishes them and "go into eclipse," as Waterton happily said, putting on for several weeks a dingy garb much resembling that of the other sex, to resume their gay attire only when, their new quills being grown, it can be safely flaunted in the open air. Here we have the first instances of Additional Mould to be mentioned. Another is not less interesting, though ornithologists must confess with shame that they have not sufficiently investigated it. This is that of the Ptarmigan (*Lagopus scoticus*), both sexes of which not only moult after the breeding-season is over into a grey suit, and then again as autumn passes away into their snowy winter-clothing, but, divesting themselves of this last in spring, then put on each a third and most distinctive dress—these changes, however, do not extend to the quills either of the wings or tail.<sup>4</sup>

The number of Birds which undergo a more or less entire Double Mould is very considerable, and the peculiarity is not always characteristic of families or even, unless in a restricted sense, of genera. Thus while the Garden-Warbler (*Sylvia salicaria*) is said to moult twice in the year the Blackcap (*S. atricapilla*) does so but once. The same may be said of the *Emberizida*, in which family both practices seem to obtain, but on the other hand the distinction in this respect between the Larks (*Alaudida*) and the Pipits (*Anthina*), belonging to the family *Motacillida*, appears, so far as our knowledge goes, to be invariable, though the habits and general appearance of both groups are so much alike—the *Alaudida* moulting but once and the *Anthina*, conforming to the practice of the normal *Motacillida* (*Motacillina*), twice a year—the quills, be it understood, excepted. But it would be impossible here to give more than these few examples, and indeed we scarcely know anything of the subject outside of groups belonging to the Northern hemisphere.<sup>5</sup>

In a large number of species the Additional Mould is very partial, being often limited to certain portions of the plumage, and it is yet an unsolved problem how far some of the changes to be observed are due to actual Mould and how far to the alteration of colour in the feathers themselves, as also the way by which this alteration of colour is produced, whether, as certainly happens in many instances, by the dropping off of the "barbicles"—the fine filaments that fringe the "barbicles" which are arranged on the upper surface of each "barb" composing the web of the feather—or in some other manner. With either of these last considerations we need not now concern ourselves. It is unquestionable that there are innumerable species of birds, the males at least of which put forth in spring decorative plumes unknown at any other season, and it would appear that in the majority of them the feathers which before clothed the parts whence the newly-donned ornaments grow are doffed to make room for these paraphernalia of marriage.

The subject of Additional Mould is thus intimately connected with the seasonal adornment of Birds, and as that

<sup>1</sup> One species, *Micropterus cinereus*, seems never to regain the power of flight thus lost. Cf. Cunningham, *Proc. Zool. Soc.* 1871, p. 362.

<sup>2</sup> Macgillivray (*Brit. Birds*, i. p. 196, London: 1857; and *Nat. Hist. of Decade*, p. 405, London: 1855) thought there were few moults in this species, but that seems to be one too many. Herr Meves (*loc. cit.*) and the Abbé Caire (*Rev. Zool.* 1854, p. 494) independently made the discovery of the Triple Mould, and almost simultaneously announced it. Cf. Gloger, *Journ. für Orn.* 1856, p. 461.

<sup>3</sup> The fullest list as yet published is that of Herr Meves (*loc. cit.*), but it is not entirely free from error.

<sup>1</sup> This is a valuable paper by Herr Meves, of Stockholm (*Öfvers. K. Vet. Akad. Förhandl.* 1854, p. 258), of which a German translation with some additions by the author may be found in *Journ. für Ornith.* 1855, pp. 230-238.

<sup>2</sup> For the knowledge of this fact the writer is indebted to the vast experience of Mr Bartlett.







skull, and the skin is then dried in a smoky hut. The Great Emerald Bird, so far as yet known, is only found in the Aru Islands. The Lesser Bird of Paradise (*Paradisæa minor*), though smaller in size and somewhat less brilliant in plumage, in other respects closely resembles the preceding species. It is also more common, and much more widely distributed, being found throughout New Guinea and the neighbouring islands. Its plumes are those most generally used as ornaments for ladies' head-dresses. It has been brought alive to Europe, and has been known to live for two years in the gardens of the Zoological Society of London. Both species are omnivorous, feeding voraciously on fruits and insects. They are strong, active birds, and are believed to be polygamous. The King Bird of Paradise (*Cicinnurus regius*) is one of the smallest and most brilliant of the group, and is specially distinguished by its two middle tail feathers, the ends of which alone are webbed, and coiled into a beautiful spiral disc of a lovely emerald green. In the Red Bird of Paradise (*Paradisæa rubra*) the same feathers are greatly elongated and destitute of webs, but differ from those in the other species, in being flattened out like ribbons. They are only found in the small island of Waigiu off the coast of New Guinea. Of the Long-billed Paradise Birds (*Epimachida*) the most remarkable is that known as the "Twelve-wired" (*Seleucidés alba*), its delicate yellow plumes, twelve of which are transformed into wire-like bristles nearly a foot long, affording a striking contrast to the dark metallic tint of the rest of its plumage. Like the *Paradisæida* they feed on insects and fruits.

**BIRKBECK, GEORGE**, an English physician and philanthropist, born at Settle in Yorkshire in 1776. He early evinced a strong predilection for scientific pursuits; and in 1799, after graduating as doctor of medicine, he was appointed to the chair of natural philosophy at the Andersonian Institution of Glasgow. In the following year he delivered, for the benefit of the working-classes, a gratuitous course of scientific lectures, which were continued during the two following years and proved eminently successful. He removed to London in 1804, and there he endeavoured to prosecute his philanthropic schemes, at first without much encouragement, but ultimately with marked success. In 1827 he contributed to found the Mechanics' Institute, his coadjutors being Bentham, Wilkie, Cobbett, and others. He was appointed director of the institute, which he had originally endowed with the sum of £3700, and held the office till his death in December 1841.

**BIRKENHEAD**, a seaport, market-town, extra-parochial district, township, and parliamentary borough, in the hundred of Wirral and west division of Cheshire, England. It is situated on the western bank of the Mersey, directly opposite Liverpool. It is of considerable antiquity, its history dating from 1180, when a priory was founded in honour of St Mary and St James by the third baron of Dunham Massey, and had considerable endowments. The priors sat in the parliaments of the earls of Chester, and enjoyed all the dignities and privileges of palatinate barons. A fine crypt and some interesting ruins of the priory still exist. From a comparatively obscure fishing village Birkenhead has become a large and important town, with a rapidity truly marvellous. The inhabitants numbered only 200 in 1821; in 1831 they were 2669; the following table shows the increase since 1841:—

Year.	Population.	Dwelling Houses.	Rateable Value.
1841	8227	1466	£44,000
1851	25,000	4148	114,801
1861	87,796	5239	150,827
1871	45,418	7511	219,011
1875-	(estim.) 52,000	8000	228,909

Birkenhead began to develop itself as a market-town in the year 1833, when an Act was obtained for paving, lighting, watching, cleansing, and improving the town, and for regulating the police and establishing a market. By this Act the Improvement Commissioners were originally constituted, and at that time included the mayor, bailiffs, and four aldermen of Liverpool. Immediately after the passing of this Act the town made rapid progress. The principal streets were laid out on a regular plan, intersecting each other at right angles. A line of tramway, the first laid in England, affords every facility of street communication. Hamilton Square, which occupies the summit of the rising ground near the river, forms the basis or starting point for all the parallel and rectangular lines of streets. The houses of the square are four stories in height, with stone fronts, the centres and ends of each terrace being relieved or ornamented with columns and porticos in the Tuscan order of architecture.

Birkenhead has (exclusive of the out townships) nine churches belonging to the Established Church. St Mary's, built in 1821 by Mr. F. B. Price, late lord of the manor, is in the Decorated Gothic style of architecture, with a well-proportioned tower and spire. The churchyard includes the burial ground and ruins of the ancient priory and chapel of St Mary. In addition to the Established churches there are twenty-four places of worship belonging to various Nonconforming denominations, viz., five Presbyterian, three Independent or Congregational, 2 Baptist, four Wesleyan, one Primitive Methodist, one Society of Friends, two Plymouth Brethren, three Roman Catholic, one Catholic and Apostolic, two Unitarian. Many of these buildings are fair examples of Gothic and classic architecture. St Aidan's Theological College, in connection with the Established Church, occupies a fine and elevated site adjoining the western boundary of Cloughton. It is a handsome building in the Tudor style of architecture. There are seven public elementary schools in connection with the Established churches, and seven in connection with other religious bodies. There is also a first-class proprietary school, conducted on the model of the great public schools, besides several private academies.

There are several public buildings in Birkenhead worthy of notice. The market-hall is a large and commodious building, 430 feet long and 130 feet wide, with substantial and lofty vaults extending under its entire area. It was opened in 1845, and built at a cost of £35,000. The public slaughter-houses in Jackson Street, belonging to the Birkenhead Commissioners, form an extensive pile of buildings; they were erected in 1846 at a cost, exclusive of the site, of about £11,000, and were the first public slaughter-houses of any extent erected in England. The town water-works also belong to the Birkenhead Commissioners, and consist of two pumping stations, the wells of which yield an aggregate supply of about 2½ million gallons in twenty-four hours. The town-hall in Hamilton Street is a one-story building, and formed when first erected the front of the old market-hall; it contains a police court, fire-engine station, and chief bridewell; there are, besides, two branch bridewells. Among other buildings are the post-office in Conway Street, the borough hospital, and the School of Art, also in Conway Street, both erected by the late Mr John Laird, M.P., and a free library in Hamilton Street. The large and commodious industrial schools in Corporation Road were built at the cost of Sir Wm. Jackson, Bart., as a memorial to the late Prince Consort. The Music Hall and the Queen's Hall are situated in Cloughton Road. There is also a neat and commodious theatre and opera-house in Argyle Street.

Birkenhead Park, opened in 1847, occupies 190½ acres of ground, and was laid out at a cost (including the land) of

£140,000. Birkenhead Cemetery, on Flaybrick Hill, occupies 20½ acres of ground, and cost about £40,000.

Woodside Ferry may be regarded as the principal entrance to Birkenhead and Wirral from Liverpool; and its exclusive right of ferryage dates back to 1332. In 1842 the Birkenhead Commissioners purchased this ferry, under an Act of Parliament, from Mr F. R. Price, the lord of the manor. At the present time the annual receipts for passengers alone amount to £36,000, and the number of persons conveyed in the twelve months is upwards of nine millions, the single fare being one penny. A large landing-stage, 800 feet in length and 80 feet in width, is moored at this ferry, the passenger traffic being conducted to and from the stage by means of a double gangway bridge, covered by two circular glass and iron roofs. The goods traffic is conveyed to and from the stage by a well-constructed floating bridge, 670 feet in length and 30 feet in width, which enables the traffic to be carried on at any state of the tide. Handsome and commodious saloon steamers, built and designed upon an improved principle, and capable of carrying above 1700 passengers each, are now used upon this ferry. The late Mr William Laird, whose name is so well known in connection with iron shipbuilding, first conceived the idea of turning to advantage the capabilities of Wallasey Pool for the formation of a dock. After a lapse of many years, the Commissioners of Birkenhead, alive to the advantages which this project would confer upon the town, employed the late Mr Bendel as their engineer, and applied to Parliament for powers to construct the necessary works. The foundation-stone of the new docks was laid in October 1844, and the first dock was opened by the late Lord Morpeth on 5th April 1847. Subsequently, the dock powers of the Commissioners were entrusted to a corporate body of trustees who afterwards transferred the property to the corporation of Liverpool; and ultimately it was vested in the Mersey Docks and Harbour Board, a corporation created by the Act of 1857 for the management of the docks on both sides of the Mersey. At that time the area of the dock space open and in use in Birkenhead was about 7 acres.

The docks bound the town on the north and north-east and partly on the east, extending from the landing-stage at Woodside Ferry to the Wallasey Bridge, a distance of over two miles. The Great Float has been constructed on the site of the Wallasey Pool, forming an immense dock of 150 acres, with a quay space of about five miles. The Great Float separates Birkenhead from Poulton-cum-Seacombe, in the parish of Wallasey, and communicates on the east with a low water basin of about 14 acres (now being converted into a dock) and the Alfred Dock (about 8 acres, and quay space 460 lineal yards), and on the south-east with the Egerton, Morpeth, and Morpeth Branch Docks. The Morpeth Dock (about 11 acres, quay space 1299 lineal yards) is connected with the Morpeth Branch Dock (about 3½ acres, quay space 600 lineal yards), both set apart for steamers. The total water area of these docks is about 170 acres, and the lineal quay space about 10 miles.

The entrances to the Birkenhead Docks are capable of docking the largest class of steamers afloat. The massive iron bridges across the dock entrances are opened and closed by hydraulic power, which is likewise applied to the cranes, coal hoists, warehouse lifts, and other appliances about the docks. At the extreme western end of the West Float are three large graving docks, two about 750 feet in length, and 130 feet and 80 feet in width respectively, and the largest, now in course of construction, measuring about 900 feet in length and 130 feet in width.

Substantial and commodious sheds and warehouses have been erected at various places along the dock quays for the full development of the traffic.

The block of warehouses known by the name of the corn warehouses are immense piles of buildings, with a canal between to give access to the separate blocks of buildings, and with machinery for carrying the grain, &c., from floor to floor, and for despatching it by railway.

In 1847 the Birkenhead Dock Warehousing Company opened their first warehouses, capable of storing 80,000 tons of goods. Each block is detached, and the whole premises are surrounded by a wall 12 feet high. A railway branch, called the Dock Extension Railway, is carried round the property. The company also built blocks of houses for their workmen, known as the Dock Cottages. This property is now in the hands of the Mersey Docks and Harbour Board.

The commerce of Birkenhead is in all respects a branch of that of Liverpool, and chiefly devoted to coal, guano, and grain,—the quantity of coal alone exported being over one million tons per annum. Many manufactories have sprung up within the last few years on the margin of the Great Float and other parts of the town, such as iron foundries, boiler-works, oilcake and seed mills, &c., some of the engineering works, shipbuilding yards, and forges being on a large scale. The Birkenhead Iron-works of Messrs Laird Brothers employ from 3000 to 4000 men; these works, in connection with their shipbuilding yards, have turned out some of the largest iron-clad ships; the engine-works, also belonging to the same firm, are on a very extensive scale. The Canada Works, belonging to Messrs Thomas Brassey and Co., carry on an extensive business in marine engines, iron-bridge building, pontoon and general railway work. There are also the Britannia Works (Messrs James Taylor and Co.) for portable engines, marine engines, traction engines, steam cranes, &c.; Messrs Clay and Inman's Forge, for heavy shafting, &c.; the Wirral Foundry, for large engine castings, &c.; and the Starbuck Car and Waggon Co.'s Works, for building tramway cars, &c.; and Messrs Clover and Clayton's shipbuilding premises as well as other manufactories of less extent.

The affairs of the township of Birkenhead and Claughton-cum-Grange are managed by twenty-one Commissioners, chosen by the ratepayers. The town contains a head post-office, county court, police court, petty sessional court for the hundred of Wirral, and two banks. Two newspapers are published weekly. The principal market-day is Saturday, but a large hay, straw, and vegetable market is held on Tuesdays in the hay market, a large open space of ground, having an area of about 1½ acres. The total area of the Commissioners' district is 1684 acres, including 365 acres of water space, viz., Birkenhead, 1248 acres, and Claughton-cum-Grange, 436. The parliamentary borough of Birkenhead was constituted in 1861, and returns one member to parliament. Its parliamentary limits include the extra-parochial chapelry of Birkenhead, the several "townships of Claughton, Tranmere, and Oxton, and so much of the township of Higher Bebington as lies to the eastward of the road leading from Higher Tranmere to Lower Bebington." The population of this district in 1861 was 51,649, and in 1871 it had increased to 64,671.

BIRMINGHAM, the fourth town in size and population in England, and the fifth in the United Kingdom, is situated at the extreme north-west of the county of Warwick, in 52° 59' N. lat. and 1° 18' W. long. It is 102 miles in a straight line N.W. of London, from which it is distant 112 miles by the North-Western Railway. The Roman Road, known as the Ikenield Street, runs through the town. On the north Birmingham touches Staffordshire, and on the south and west Worcestershire, the suburbs of the town extending largely into both these counties—Harborne and Handsworth being in the former and Balsall,

Moseley, and Yardley in the latter. The borough itself, however—both parliamentary and municipal, the boundaries being identical—is wholly in the county of Warwick. It covers an area of 8420 acres (of which 5900 are built upon), and includes the whole of the parishes of Birmingham and Edgbaston, and about one-third of the parish of Aston. It is nearly 6 miles long, has an average breadth of 3 miles, is 21 miles in circumference, and has 190 miles of streets and roads. The population, at the census of 1871, was 343,000; and in June 1875 it was estimated by the registrar-general at 360,000. Birmingham was enfranchised by the Reform Act of 1832, when two representatives were assigned to it—and Mr Thomas Attwood and Mr Joshua Scholefield (leaders of the Political Union) were elected; by the Reform Act of 1867 this number was

raised to three. A grant of incorporation was made to the town in 1838, when the first municipal council was elected. In 1870 a School Board of fifteen members was elected, under the Elementary Education Act passed in that year.

The town is built upon the New Red Sandstone, on a boldly undulated site, varying from 200 to 600 feet above the sea-level, steadily rising towards the north and west, so that when looked at from the heights on the south-east side it presents the appearance of a vast semicircle, picturesquely disposed, the masses of houses being broken by spires and lofty chimneys, and the south and west sides being thickly wooded on the slopes. The plan of the town is irregular, and the streets are mostly winding, and many of them somewhat narrow. In the centre, however, is a large open space, known as the Bull Ring and High



Sketch-Plan of Birmingham.

Street, at the foot of which stands the mother church of St Martin, and in which is situated the Market-Hall, one of the largest buildings of its kind in the kingdom. From this centre access is obtained to the principal streets, New Street and High Street; the former, about a quarter of a mile in length, derives a most picturesque appearance from its slightly curved form, and from the effective manner in which the sky-line is broken by lofty buildings alternating with others of lower altitude. This street contains the Exchange, the Grammar School, the Theatre Royal, the rooms of the Royal Society of Artists, which have a fine Corinthian portico stretching across the pavement. At the upper end of the street is the Town-Hall, and close to this are the corporate buildings and the Post-Office. The last quarter of a century has seen a great advancement in the style and accommodation of the public and commercial edifices; streets have been widened and new roads opened,

and the place has altogether put on a livelier and wealthier look. Excepting in some of the older and poorer districts, the private houses have undergone a corresponding improvement. The richer classes live chiefly in the parish of Edgbaston, which belongs almost entirely to Lord Calthorpe, and in which strict rules as to the description, position, and area of the houses are enforced. The streets inhabited by the working-classes are, of course, more crowded, and many of the houses are built in enclosed courts, access to which is gained from the street, either by openings between the houses, or by narrow entries, too commonly built over, and thus impeding the free passage of air. Many of the courts, however, are wide enough to allow of small gardens in front of the houses, while in the suburbs almost every house is provided with a garden of some kind; and in a considerable number of cases the houses, through means of building societies, have become

the property of the workmen themselves. The habit exists among all classes of each family (with rare exceptions) occupying a separate house, a practice which greatly affects the area of the town. Thus, to a population of 360,000 there are about 76,000 inhabited houses, giving an average of five persons to a house. Birmingham is a town of rapid growth. In 1700 the population was about 15,000. A century later, at the census of 1801, it had increased to 73,000. In the next thirty years the population doubled, being 147,000 in 1831. The same process was repeated in the following term of thirty years, the population in 1861 being 296,000. Between 1861 and 1871 the increase was 47,000, and the returns of the registrar-general show that the same rate of progress is still going on. It is, however, likely to be checked by the increasing value of land within the borough, by the absorption of available sites for building, and by the consequent overflow of population into the suburbs. If these, inhabited solely by borough people, are taken into account, the real population at present is probably not far short of half a million.

**Government.**—The government of the town resided originally in the high and low bailiffs, both officers chosen at the court of the lord of the manor, and acting as his deputies. The system was a loose one, but by degrees it became somewhat organized, and Crown writs were addressed to the bailiffs. In 1832, when the town was enfranchised, they were made the returning officers. About the beginning of the century, however, a more regular system was instituted, by an Act creating a body of street Commissioners, who acted for the parish of Birmingham,—the hamlets outside its boundaries having similar boards of their own. The annoyance and difficulty caused by these bodies—thirteen in number—led to a demand for the incorporation of Birmingham as a borough; and a charter was accordingly granted by the Crown in 1838, vesting the general government in a mayor, sixteen aldermen, and forty-seven councillors. The powers of this body were, however, unusually restricted, the other local governing bodies remaining in existence. It was not until 1851 that an Act of Parliament was obtained, abolishing all governing authorities excepting the Town Council, and transferring all powers to this body. Under this Act, and another local Act obtained in 1862, the affairs of the town are now administered, the whole municipal government being in the hands of the Town Council. The importance of the duties discharged by the Council may be inferred from the fact that it has under its control nearly 200 miles of street and road, that it has a police force of nearly 500 men, and that its revenue, derived from tolls and rates, amounts to about £300,000 a year. These responsibilities have been increased by the purchase in 1875 of the gas and water-works (the latter with a daily supply of 17,000,000 gallons), the two purchases making a cost of more than £3,000,000. The growth of the revenue and expenditure of the town, its rateable value, and its ordinary debt, excluding the gas and water-works, will be seen from the following tabular statement:—

Year.	Amount of Assessment to the Borough Rate	Total Amount of Rate in the £	Income	Expenditure.	Balance of Public Debt.
1854	£ 645,949	£ 5	120,237	131,723	366,095
1859	824,869	3 4	157,121	186,987	467,002
1864	920,191	3	187,620	185,587	688,308
1869	1,052,796	3 2	195,155	199,960	588,449
1874	1,254,911	3 10½	289,656	271,807	664,959

*N.B.*—The amount of property possessed by the Corporation on 31st December 1874, taken at its original cost, was £1,269,047.

<sup>1</sup> Including rate for School Board, 8d. in the £.

The administration of the poor-law is vested in a Board of Guardians, of sixty members, for the pariah Birmingham.

The parish of Edgbaston (wholly within the borough) is in the poor-law union of King's Norton, and that part of the parish of Aston included in the borough is in the Aston Union. There are three workhouses—that for Birmingham parish, situated at Birmingham Heath, is capable of receiving over 2000 inmates. In the week ending June 19, 1875, there were chargeable to the pariah (including lunatics and persons receiving outdoor relief) 6949 paupers, a very small number in proportion to population.



Arms of Birmingham.

Birmingham has a grant of quarter sessions, with a recorder, and petty sessions are held daily at the Sessions Court, in Moor Street, before a stipendiary magistrate, and a bench of borough justices. The justices for the borough and Aston division of Warwickshire also sit here occasionally. The borough justices have charge of the administration of the gaol. The town is the head of a county court district, and is the seat of the probate registry for Warwickshire.

**Religious Denominations, Buildings, &c.**—Until the year 1821 Birmingham was in the diocese of Lichfield and Coventry; it is now in the diocese of Worcester and archdeaconry of Coventry, and is a rural deanery. There was formerly a religious house, the priory of St Thomas the Apostle, and a Guild of the Holy Cross, an association partly religious and partly charitable, having a chantry in the parish church. The possessions of the priory went to the Crown at the dissolution, and the building was destroyed before the close of the 16th century. The lands of the Guild of the Holy Cross were granted by Edward VI. to trustees for the support of a free grammar school; they are now of the value of nearly £15,000 a year. Until 1718 there was but one parish church, St Martin's, a rectory, having the tithes of the entire parish of Birmingham. St Martin's was erected about the middle of the 18th century; but in the course of ages was so disfigured, internally and externally, as to present no traces, except in the tower and spire of its former character. In 1858 the tower was found to be in a dangerous condition, and together with the spire was rebuilt. In 1873 the remaining part of the old church was removed without disturbing the monuments, and a new and larger edifice was erected in its place, at a cost of nearly £30,000. The new church constitutes the chief ecclesiastical edifice in Birmingham, and indeed the handsomest structure in the town. St Philip's, a stately Italian structure, designed by Archer, a pupil of Wren, was the next church erected. It was consecrated in 1715. Then followed St Bartholomew's in 1749, St Mary's in 1774, St Paul's in 1779, St James's, Saught, in 1791, and others, which need not be mentioned, followed in due course. At present the mother parish is divided into five rectories, and there are within the borough, including those mentioned, 42 churches (each having an ecclesiastical district assigned to it) of the Church of England, most of these having schools and missions attached to them.

Under the Commonwealth Birmingham was a stronghold of Puritanism. Clarendon speaks of it and the neighbourhood as "the most eminently corrupted of any in England." Baxter, on the other hand, commending the garrison of Coventry, says it contained "the most religious men of the parts round about, especially from Birmingham." The traditional reputation for Nonconformity is maintained by the town, all varieties of dissenters being numerous and influential.

The Unitarians, the oldest body established here, have six chapels. One of these, the Old Meeting, is historically interesting, the congregation having been formed on the Presbyterian model by a number of ministers ejected under the Act of Uniformity. Another chapel, the New Meeting, in Moor Street (now occupied by the Roman Catholics), is memorable as having been the place of Dr Priestley's ministerial labours. In 1862 the Unitarians removed from this place to a new Gothic edifice, called the Church of the Messiah, in Broad Street, where they still preserve a monument of Priestley, with a medallion portrait in profile, and an inscription written by Priestley's friend, Dr Parr. The Society of Friends, whose first meeting-house dates from about 1690, have now three places of meeting. The Independents have now eleven chapels, several of them large and flourishing. The Baptists first erected a chapel in Cannon Street in 1738. They have now 16; one of them, Wycliffe Chapel, Bristol Road, is a singularly handsome structure of 14th century Gothic. The Wesleyan Methodists were established in Birmingham by John Wesley himself in 1745, when he was roughly handled while preaching on Coote Green. For some years they

worshipped in temporary premises. They have now 17 places of worship; and the other divisions of the Methodist body have 24 in the aggregate. The Presbyterians possess 5 places of worship, and the Jews have a handsome synagogue. The Roman Catholics have paid special attention to Birmingham. From the Revolution of 1688 until 1789 they had no place of worship here. They now have a bishop (who assumes a title from the town), a cathedral, and 9 other churches or chapels, a cemetery, and other establishments in the suburbs, including several religious houses, including the Oratory, founded by Dr Newman. The principal edifice is the cathedral of St Chad, built from the designs of Mr Pugin, at a cost of more than £30,000.

The religious institutions and societies in Birmingham are very numerous, and with these are associated many establishments of a benevolent character, such as almshouses, asylums, refuges, societies for the aid of discharged prisoners, and for the promotion of religious education in Board schools, training institutions for nurses and servants, and others of various kinds, in the management of which persons of different religious opinions are commonly found working together in friendly association.

**Charities.**—These are numerous. The principal is the General Hospital, Summer Lane, opened in 1779; it was founded by Dr Ash, an eminent local physician. The yearly average of in-patients is about 2800, of out-patients, 25,000. The Queen's Hospital, Bath Row, the other large hospital of the town, was founded in 1840 by Mr W. Sands Cox, F.R.S., an eminent local surgeon, who also founded the Queen's College as a medical school. This hospital receives annually about 1800 in-patients and 17,000 out-patients. The General Dispensary, the officers of which visit patients at their own homes, relieves about 8000 yearly. The Children's Hospital (free), established in 1864 by Dr Heapel, relieves about 15,000 out and 1000 in-patients. It has two establishments—for out-patients (a very handsome Gothic building) in Steelhouse Lane, and an in-patient department in Broad Street. There is also a Women's Hospital (free) for the special diseases of women; a lying-in charity; special hospitals for diseases of the eye, the ear, bodily deformities, and the teeth; and a homoeopathic hospital. The parish of Birmingham maintains a large infirmary at the workhouse (Birmingham Heath), and a dispensary for out-patients in Paradise Street.

Nearly all these medical charities depend upon subscriptions, donations, legacies, and income from invested property; and the sum raised in this way is probably nearly £20,000 a year. There are two public organisations for aiding the charities, both of which were begun in Birmingham. One is a simultaneous collection in October in churches and chapels, called the Hospital Sunday, established in 1859, and now yielding over £5000 a year; the other is the Saturday Hospital collection, made by the work-people in March, which was established in 1873, and yields about £4000.

There is also a Sanatorium at Blackwell, near the Lickey Hill, about 10 miles distant, common to all the hospitals. Amongst the non-medical charities the principal are the Blind Institution and the Deaf and Dumb Asylum, both at Edgbaston; and Sir Josiah Mason's Orphanage at Erdington, which receives 300 orphan children, and was built and endowed at the cost of about £250,000 solely by Sir Josiah Mason, a Birmingham penmaker. There are also in the town numerous almshouses for aged persons, the chief of which are Leach's Trust, the James Charities, the Licensed Victuallers' Asylum. Besides the general benefit societies, such as the Oddfellows', Foresters', &c., which are strongly supported in Birmingham, the work-people have numerous clubs of a charitable kind, and there are several important local provident societies of a general character, with many thousand members.

**Education.**—The oldest and principal institution is the Grammar School of King Edward the Sixth, founded in 1552, out of the lands of the Guild of the Holy Cross, then of the annual value of £21, but now yielding about £15,000 a year, with a prospect of large increase. The principal or high school, in New Street, was erected in 1840, in the Perpendicular period of the Gothic style, from designs by Sir Charles Barry, at a cost, including land, of £71,000. This school is divided into two departments, classical and English, and educates about 600 boys; while connected with it there are four elementary schools for boys and girls, used chiefly by the lower middle class, the number of pupils being 1500. The classical school has ten exhibitions of £50 each, tenable at Oxford or Cambridge. The next most important foundation is that of the Midland Institute, which includes a general literary department (lectures, museums, and reading-rooms), and an industrial department, with classes in science, languages, mathematics, arithmetic, history, literature, and the laws of health. There are about 600 science students, and about 1600 in

the other departments. The Queen's College, originally a school of medicine, founded in 1828, obtained a royal charter in 1843 as a kind of university, with departments of literature, theology, law, science, and engineering. All these branches have now fallen into disuse, excepting medicine and theology; in the latter the college educates candidates for the ministry of the Church of England. An important foundation is Sir Josiah Mason's Scientific College, for the endowment of which Sir Josiah has conveyed to trustees property valued at nearly £100,000, and a capacious building, estimated to cost probably £40,000, is now in erection in Edmund Street, near the Town-Hall. Among the other educational foundations may be mentioned Spring Hill College, Moseley, for the education of Congregational ministers; four industrial schools; a large reformatory for boys at Saltley, and one for girls at Smethwick. For general education there are many private schools, of a good class, for boys and girls. Elementary education is provided in the Church of England day schools, Roman Catholic schools, and Board schools. A total provision, in all the public elementary schools, is made for 41,791 children; there are (July 1875) 51,384 on the books, with an average attendance for the previous quarter of 37,894. The School Board, though it was elected only in 1870, has, by the provision of new schools, and the exercise of compulsory powers, more than doubled the school attendance. It has already built and opened 9 schools, with accommodation for 8800 children, at a cost, for land and buildings, of about £86,000; and 8 other schools are now in progress, providing accommodation for 7400 children, at an estimated cost of about £103,000—making a total expenditure of nearly £200,000, and provision for a total of about 16,000 children.

**Libraries, &c.**—The principal libraries of the town are the Birmingham Library (belonging to a body of proprietors), founded in 1798 by Dr Priestley, and containing about 40,000 volumes, and the Corporation Free Libraries, in Ratcliff Place, commenced in 1861. These consist of a central reference library and lending library (the former containing 36,000 volumes of carefully chosen books), to which is attached a central reading-room. There are also four lending libraries and news-rooms in other parts of the town, and news-rooms are about to be opened by the Corporation in connection with the Board schools. The total issue of books from the libraries for 1874 was 521,991. Included in the reference library are a special Shakespeare library, containing almost all known editions of the plays and of works illustrating them; a library of nearly 1000 volumes, illustrating the works of Cervantes (presented by Mr W. Bragge of Sheffield); and a large and unique collection of Warwickshire books and antiquities, known as the Staunton collection. An Art Gallery and Industrial Museum is attached to the Free Libraries; and there is at Aston Hall another museum of natural history, &c., belonging to the Corporation. Art instruction is provided by the Royal Society of Artists, which has classes and lectures for students, and which holds two general exhibitions annually; and by the School of Art, which has 900 students, together with affiliated classes in schools, containing nearly 1700 students.

**Miscellaneous Institutions, Parks, &c.**—These include 8 banks, 4 principal clubs—the Union, the Midland, the Arts, and the Conservative—to which a Liberal Club is about to be added. There are 3 morning and 2 evening daily papers—4 of them Liberal and 1 Conservative—and 2 weekly papers. There are 2 theatres, 2 large music-halls, and several smaller ones. Musical festivals for the benefit of the General Hospital are held triennially, and are usually marked by the production of new and important works, and by the engagement of most of the leading

vocalists and instrumental performers. There are 5 parks and pleasure grounds belonging to the Corporation—Aston Park and Hall, 45 acres; Calthorpe Park, about 35 acres; Cannon Hill Park, 65 acres; and Adderley and Highgate Parks, each about 12 acres. Beside these there are numerous pleasure-grounds—the Botanical Gardens, Edgbaston, open to subscribers, and the Lower Grounds, a beautiful series of gardens at Aston, in which important flower shows are periodically held. Sutton Park, about 8 miles distant, and including about 3000 acres, is also much used by the Birmingham people. The Corporation has several sets of baths and wash-houses in various parts of the town. There are several extensive cemeteries.

**Public Buildings.**—Of these the Town-Hall, a nobly-proportioned and impressive edifice, is the principal. It stands at the top of New Street, and on three sides is isolated from all other buildings by broad and handsome streets. The hall, completed in 1850 at a total cost of £52,000, is severely classic, modelled upon a Greek temple. The lower stage consists of a vast plinth or basement, 23 feet high, upon which is reared a façade of peripteral character, with 8 Corinthian columns (36 feet high) at the two principal fronts, and 13 columns on each side. These columns (imitated from those of the temple of Jupiter Stator at Rome) support a bold and enriched cornice, finished at each end with a lofty pediment and entablature. The exterior of the hall is built of Anglessea marble. The interior consists chiefly of a regularly-built room, designed specially for meetings and concerts, with an orchestra containing one of the finest organs in the kingdom. The seats are arranged for an audience of 2265 persons, but when cleared of benches, as is the case at great political meetings, 5000 persons may find standing room. On one side of the Town-Hall are the buildings of the Midland Institute and the Free Libraries (of Italian design), occupying the whole of Ratcliff Place, with fronts to Paradise Street and Edmund Street. A new Art Gallery is in course of erection, fronting the latter street. At the back of the Town-Hall is the site of the new building or the Mason College (Gothic), and in front of the hall, in Paradise Street, are Christ Church (classic), the Queen's College (Gothic), and the Post-Office. On the side of the hall in Ann Street, opposite to the Midland Institute, are the new Corporate Buildings (Italian), now being erected at a cost of nearly £200,000. These will give accommodation for the Town Council, law courts, public offices, and the mayor of the borough. Lower down New Street is the building of the Royal Society of Artists (classic), with a noble portico; then comes the Exchange (Gothic) in Stephenson Place; and at the bottom of the latter street is the Central Railway station, used by the North-Western, the Midland, and their branch railways, and fronted by the Queen's Hotel. The station is more than a quarter of a mile in length. The roof, a magnificent specimen of engineering, consists of a vast arch of glass and iron, carried on pillars on each side, and measuring 1100 feet in length, 80 feet in height, and 212 feet in width in a single span. The glass in the roof weighs 115 tons, and the iron-work 1400 tons. Below the station, in New Street, is the Grammar School; and in High Street, close at hand, is the Market-Hall, a magnificent classic building, erected in 1833 at a cost of nearly £70,000, with an area of 4380 square yards, and affording room for 600 stalls. Amongst the other public buildings are the Borough Gaol at Winson Green, with 467 cells, arranged on the separate system; near this the Lunatic Asylum, with accommodation for 600 patients; and close at hand the workhouse, which receives about 2000 inmates. The General and Queen's Hospitals are also handsome buildings, the latter especially so, it being remarkable for a very noble out-patient hall. This and the out-patient

hall at the Children's Hospital in Steelhouse Lane (Gothic) are perhaps the finest rooms of their kind in the kingdom.

Birmingham had till very recently only one public monument, the statue of Nelson, by Westmacott, in High Street; but several others have been erected—namely, those of Joseph Sturge, at the Five Ways, and of Thomas Attwood, the founder of the Political Union, in Stephenson Place, both of them by the late Mr Thomas; James Watt, a singularly beautiful work, in Ratcliff Place, by the late Mr Munro; Sir Robert Peel, in New Street, by Mr P. Hollins; the late Prince-Consort, in the Art Gallery, by Mr Foley; Sir Rowland Hill, in the hall of the Post-Office, by Mr Noble; and Dr Priestley, in New Street, by Mr F. J. Williamson. Chantry's famous statue of James Watt is in a special chapel at Handsworth church.

**Manufactures.**—From an early period Birmingham has been a seat of manufactures in metal. Hutton, the historian of the town, claims for it Saxon or even British antiquity in this respect, but without the shadow of foundation. The first or direct mention of Birmingham trades is to be found in Leland's *Itinerary* (1538). He writes:—"I came through a pretty street as ever I entered into Bermingham towne. This street, as I remember, is called Dirtye (Deritend). In it dwell smiths and cutlers. There be many smithes in the towne that use to make knives and all manner of cutlery tooles, and many lorimers that make bittes, and a great many naylors, so that a great part of the towne is maintained by smithes, who have their iron and sea-cole out of Staffordshire." The cutlers no longer exist, this trade having gone to Sheffield; but the smiths remain, and the heavier cutting tools are still largely made here. The well-ascertained importance of Birmingham as a centre of manufactures began towards the close of the 17th century, one great source of it being the absolute freedom of the town, there being no guilds, companies, or restrictions of any kind; besides which the easy access to cheap coal and iron indirectly helped the development. It is remarkable that two important trades, now located elsewhere, were first established here. Steel was made in Birmingham until 1797, and was then disused for quite 70 years, when an experiment in steel-making (still carried on) was made by a single firm. Cotton-spinning was begun in Birmingham by John Wyatt, and Lewis Paul, and Thomas Warren as early as 1739; but the speculation was abandoned before the end of the century. The great staple of Birmingham is metal-working in all its various forms. The chief variety is the brass-working trade, which employs several hundred masters, and about 10,000 work-people, and consumes probably 50,000 tons of metal annually, which is worked up into an infinity of articles of ornament and utility. Iron-working, though largely carried on, is a much less important trade, works of this kind being chiefly established in the Staffordshire district. Jewellery, gold, silver, and gilt come next to brass. Then follow small arms of all kinds, some of the larger establishments being capable of turning out 2000 stand per week. Buttons, hooks and eyes, pins, and other articles used for dress, constitute a large class of manufactures. Glass, especially table glass, is a renowned staple of the town. Screws, nails, &c., are made in enormous quantities; indeed, Birmingham has a monopoly of the English screw trade. Steel pens are also a specialty—as much as, probably, 15 tons or more of steel being the weekly consumption of these articles; the largest maker, Sir Josiah Mason, rolls 5 tons weekly for his own consumption, and has about 60 tons of pens constantly in manufacture in various stages. About 20,000,000 pens are made weekly in the town, and are sold at prices ranging from 1½d. to 12s. per gross of 12 dozen. The fact that each gross requires 144 pieces of steel to go through

12 different processes, renders this cheapness of sale one of the greatest marvels of manufacturing skill and industry. Electro-plating, first established about 1848 by Messrs Elkington and Mason, is one of the leading trades. Amongst other branches of manufacture are wire-drawing, bell founding, metal rolling, railway carriage building (a large and important industry), steel-toy making (including cutting implements and tools of all kinds), die-sinking, papier-maché making, and a variety of others, for which reference may be made to a volume entitled *Birmingham and the Midland Hardware District*, prepared on the visit of the British Association in 1865, and extending to more than 700 pages. It is impossible, indeed, in smaller compass to give an adequate idea of the variety and extent of Birmingham industry. To quote a modern writer:—

“We cannot move without finding traces of the great hive of metal-makers—the veritable descendants of Tubal-cain. At home or abroad, sleeping or waking, walking or riding, in a carriage or upon a railway or steamboat, we cannot escape reminiscences of Birmingham. She haunts us from the cradle to the grave. She supplies us with the spoon that first brings our infant lips into acquaintance with ‘pap,’ and she provides the dismal ‘furniture’ which is affixed to our coffins. In her turn Birmingham lays the whole world under contribution for her materials. For her smiths, and metal workers, and jewellers, wherever nature has deposited stores of useful or precious metals, or has hidden glittering gems, there industrious miners are busily digging. Divers collect for her button makers millions of rare and costly shells. For her adventurous hunters rifle the buffalo of his wide-spreading horns, and the elephant of his ivory tusks. There is scarcely a product of any country or any climate that she does not gladly receive, and in return stamps with a richer value.”

These labours Birmingham performs with the aid of many thousands of willing hands, moved by busy and ingenious brains, and aided by her own great invention, the steam-engine; for by the genius of Watt and the intrepid courage of Boulton, Birmingham may claim the perfection of this discovery as her own. The memory of the great Soho factory is one of the most precious heritages of the town, and the name remains, for though the old factory has long since disappeared, the firm of Boulton and Watt still continue to make steam-engines in the immediate neighbourhood; and James Watt's own private workshop continues just as he left it, with no single article disturbed, carefully preserved in the garret of his house at Heathfield.

The mention of Watt and of Soho recalls the memories of distinguished inventors and others who have been connected with Birmingham. Johnson was a frequent visitor here to his friend Hector, the surgeon, on whose house in the Old Square a tablet (erected by the Shakespeare Club) bears witness to the residence of the great moralist. Then Beakerville, the printer, carried on his work here. The famous Lunar Society, fully described by Mr Smiles in his *Lives of the Engineers*, brought together a brilliant company—Watt, Boulton, Priestley, Josiah Wedgwood, Darwin, Parr, Withering, Edgeworth, Sir Joseph Banks, Herschel, Dr Solander, Fothergill, Rosebuck, Galton, Keir, and many others. Murdoch, the inventor of gas, was a Soho man, and first used his invention to light the Soho factory at the peace of Amiens in 1802. Rickman, the reviver and historian of Gothic architecture, practised as an architect in Birmingham. Hutton, the antiquary and historian, carried on his book-selling business here. Many of the best engravers were Birmingham men, notably Willmore and Pye, the special translators of Turner's marvellous creations. In the ranks of landscape painters the name of David Cox will ever confer honour upon the town. Attwood, Joseph Parkes, and Bright speak for it in the region of politics and statesmanship. The series of inventors is continued to our own day by the names of Gillott, Elkington, Chance, Mason, and others.

In many respects Birmingham is a peculiar town, and in none more than the hold it has upon the affections of its

peoples. A “Birmingham man” is usually a man of strong individuality, independence of character, facility of resource, and with an enduring love for “the old town.” These traits of character are the result of a variety of circumstances. Birmingham is peculiar in opening a career even to the humblest who are gifted with ingenuity and industry. The great number of trades keeps work fairly constant, the skill required in them sustains wages of artisans at a high level, and the distribution of labour, and its dependence upon direct personal aptitude, afford chances of rising in the social scale which cannot be found in places where manufactures are mainly of one class and are conducted in factories demanding large capital. It is easy in Birmingham for a man to become a small master, and gradually to push his trade until he is able to establish a factory. Many of the largest employers have either been workmen themselves or are the sons of workmen; while of the smaller manufacturers almost all take a direct part in the handicraft work carried on in their places of business.

Wealth is more evenly distributed than in most other places. There are no colossal fortunes in Birmingham, and comparatively few large ones, and of these very few are made by speculative operations. To compensate for these distinctions there is an unusually large comfortable class—people of good though not excessive incomes derived from solid trade, or from savings made by hard personal and associated work. This class, touching the actually wealthy on one side, by easy and almost imperceptible stages touches the actual working-class on the other, and this latter class is constantly rising into the middle rank.

The Birmingham work-people, in their way, are courteous and helpful. This is probably owing to the free and open and common discussion of subjects of political and social interest engaged in without distinction of class. The same principle is adopted educationally—in the Midland Institute, for example—the Act of Parliament which established the Institute providing that the governing council shall always include artisan members. Another noticeable characteristic of the town is the development of means of self-instruction and of self-help. Birmingham was amongst the earliest places to establish a mechanics' institution, the place of which is now more efficiently supplied by the Midland Institute. Birmingham, again, was the birthplace of the freehold land and building societies, by which workmen are enabled, on easy terms, to acquire houses of their own; and in addition to these institutions, which are numerous and flourishing, it has a very large number of sick and friendly societies, savings-clubs, and other organizations of a provident kind,—more in proportion to population than, probably, any other of the large towns in England. Amongst the social characteristics it should be mentioned that there are few serious disputes between masters and workmen, and that strikes are infrequent, and when they do occur are found capable of easy adjustment by friendly negotiation. One point more is worthy of record—the constancy of the town to those who serve it. Many of the leading manufacturers and other citizens are members of the local governing bodies, and these and the parliamentary representatives are rarely changed by their constituents.

*History.*—Owing to its rapid expansion, and the consequent newness of most of the public and other buildings, Birmingham is often supposed to be a modern town. It is really one of the oldest in the country, and was in existence as a community in the Saxon period. Proof of this was given in 1809 by William de Bermingham, then lord of the manor, who showed in a law-suit that his ancestors had a market in the place, and levied tolls, before the Conquest. Some authors have endeavoured to identify the town with the supposed Roman station called *Bramentum*, but this claim has long since been abandoned as fabulous. The origin of the name is untraceable; the spelling of it is traceable in about 100 different forms. Dugdale, the historian of Warwickshire, adopts *Brom-*

wycham, and regards it as of Saxon derivation. Hutton, the historian of Birmingham, has the fanciful etymology of *Brem* (broom), *wyeh* (a descent), and *Aem* (a home), making together, the home on the hill by the heath. As regards the history of the town, we must agree with Hutton that "the way is long, dark, and slippery." In *Domesday Book* it is rated at four miles of land with half a mile of woods, the whole valued at £308. Two hundred years later the family of De Bermingham, the owners of the place, come into sight,—one of them, William, being killed at the battle of Evesham, in 1265, fighting with Simon de Montfort and the barons against Henry the Third. The son of this William afterwards took part in the French war, and was made prisoner; his father's estates, forfeited by treason, were restored to him. Thenceforward we find the family engaged in various local and other offices, but seemingly abstaining from politics. They held the place until 1827, when Edward de Bermingham was deprived of his property by means of John Dudley, duke of Northumberland, who trumped up a pretended charge of riot and robbery against him, and procured Birmingham for himself. On the attainder of Dudley the manor passed to the Crown, and was granted to Thomas Marrow, of Berke-well, from whom by marriage and descent it went to Christopher Musgrave, and finally, as regards the only valuable part—the market tolls—by purchase to the town itself. In the Wars of the Roses it does not seem that Birmingham took any part; but energy revived in the civil war under Charles I., when the town sided actively with the Parliamentarians. In 1642, when Charles was marching from Shrewsbury to relieve Banbury, the Birmingham people seized part of his baggage, including much plate, money, and wine, which they sent to the Parliamentary garrison at Warwick. Before the battle of Edgehill Charles rested for two nights at Aston Hall, near the town, as the guest of Sir Thomas Holte. The Birmingham people resented this by helping the Parliamentarians to cannonade the hall and to levy a fine upon Sir Thomas Holte. They also set to work, and supplied the Parliamentary army with 15,000 sword blades, refusing to make a single blade for the Royalists. These manifestations of hostility were avenged in April 1648, by Prince Rupert, who, with 2000 men and several pieces of artillery, attacked the town, planting his cannon on an eminence near Sparkbrook, still known as Camphill. The townspeople resisted, but were beaten, many persons being killed or wounded. Amongst the former was Lord Denbigh, one of the Royalist officers. Having captured the place, Prince Rupert allowed his troops to plunder it, to burn about eighty houses, and to set their prisoners to ransom. He also levied a fine of £30,000, equal to at least £100,000 of the present value of money. This bitter lesson kept Birmingham quiet during the rest of the civil war, though the sympathies of the people with the Parliamentarians were unabated. In 1665 Birmingham suffered heavy losses by the plague, great numbers of dead being buried in the Pest Field, at Lady-wood, then a lonely place far outside the town, but long since thickly covered with buildings. In 1688 the Revolution provoked a temporary outbreak of Protestant feeling. James II. had given timber from the royal forest of Needwood, near Burton, to build a Catholic chapel and convent in a place still called Mass-house Lane. This edifice the mob promptly destroyed when James gave place to William and Mary. Rather more than a century of quiet prosperity ensued, and then occurred the serious and most lamentable outbreak of popular fury known as the Church and King riots of 1791. For some years there had been much political activity in Birmingham, the dissenters, particularly the Unitarians, being desirous of relief from the political and religious disabilities under which they laboured. The leader in these movements was the famous Dr Priestley, who kept up an active controversy with the local clergy and others, and thus drew upon himself and his co-religionists the hatred of the more violent members of the Church and Tory party. The smouldering fire broke out on the occasion of the French Revolution. On the 14th of July a dinner of Birmingham Liberals was held at the Royal Hotel to celebrate the destruction of the Bastille. This was the signal of a popular outbreak. A Church and King mob, encouraged and organized by leaders of better station, but who were too cowardly to show themselves, began an attack upon the Unitarians. Dr Priestley was not present at the dinner, but his house at Fair Hill, Sparkbrook, was one of the first to be sacked and burnt—his library and laboratory, with all his manuscripts, the records of life-long scientific and philosophical inquiries, perishing in the flames. The house and library of Hutton, the historian and antiquary, were also destroyed. The Unitarian chapel was burnt, and several houses belonging to members of the sect were sacked and burnt. The riot continued until a strong body of troops was marched into the town, but before their arrival damage to the amount of more than £60,000 had been done. Some of the rioters perished in the burning buildings, in the cellars of which they drank themselves into stupefaction. Others were tried and imprisoned, and four of the prisoners were hanged. The persecuted Unitarians recovered a small part of their losses from the county; but Dr Priestley himself, owing to the unworthy prejudice against him, was in a great measure forced to remove to the

United States of America, where he spent the rest of his life. A late atonement was made by the town to his memory in 1873, by the erection of a statue in his honour in front of the Town-Hall, and the foundation of a Priestley scholarship at the Midland Institute.

As if ashamed of the excesses of 1791, Birmingham thenceforth became a thoroughly Liberal and, with one or two exceptions, a peaceful town. In the dismal period from 1817 to 1819, when the manufacturing districts were heavily distressed and were disturbed by riots, Birmingham remained quiet. Even when some of the inhabitants were tried and punished for demanding parliamentary representation, and for electing Sir Charles Wolesey as their delegate, there was no demonstration of violence—the wise counsels of the leaders inducing orderly submission to the law. The same prudent course was observed when in the Reform agitation of 1831–32 the Political Union was formed, under the leadership of Thomas Attwood, to promote the passing of the Reform Bill. Almost the whole town, and great part of the surrounding district, joined in this agitation; vast meetings were held on Newhall Hill; there was much talk of marching upon London 100,000 strong; but, owing to the firmness and statesmanship of Mr Attwood and his associates, there was no rioting or any sign of violence. Ultimately the Political Union succeeded in its object, and Birmingham helped to secure for the nation the enfranchisement of the middle classes and other political reforms. One exception to the tranquillity of the town has to be recorded—the occurrence of riots in 1839, during the Chartist agitation. Chartism took a strong hold in Birmingham, and, under the influence of Mr Feargus O'Connor and some of his associates, nightly meetings of a threatening character were held in the Bull Ring. The magistrates resolved to put these down, and having obtained the help of a detachment of the metropolitan police—the town then having no local police force—a meeting was dispersed, and a riot ensued, which resulted in injury to several persons, and required military force to suppress it. This happened on the 4th of July. On the 15th of the same month another meeting took place, and the mob, strongly armed and numbering many thousands, set fire to several houses in the Bull Ring, some of which were burned to the ground, and others were greatly damaged. The military again interfered, and order was restored, several of the ring-leaders being afterwards tried and imprisoned for their share in the disturbance. There was another riot in 1867, caused by the ferocious attacks of a lecturer named Murphy upon the Roman Catholics, which led to the sacking of a street chiefly inhabited by Irishmen; but the incident was comparatively trivial, and further disorders were prevented by the prompt action of the authorities. (J. T. B.)

**BIRON, ARMAND DE GONTAULT**, a baron and marshal of France, and a celebrated general, who signalized himself by his valour and conduct in several sieges and battles in the 16th century. He was made grand master of the artillery in 1569, and commanded at the siege of Rochelle, and in Guienne. He was one of the first who declared for Henry IV.; he brought a part of Normandy under his subjection, and dissuaded him from retiring to England or Rochelle. Biron was killed by a cannon-ball at the siege of Epernay, July 26, 1592. He was a man of considerable literary attainments, and used to carry a pocket-book, in which he noted everything that appeared remarkable. This gave rise to a proverb at court, when a person happened to say anything uncommon, "You have found that in Biron's pocket-book."

**BIRON, CHARLES DE GONTAULT**, son of the above and born in 1562, created duke of Biron and admiral of France by Henry IV., was a man of great intrepidity, but fickle and treacherous. In 1601 he was sent as ambassador to the court of queen Elizabeth to announce his royal master's marriage with Mary of Medici; but being discovered in a treasonable correspondence with Spain, he was beheaded in the Bastille at Paris, July 31, 1602. The extent to which he had carried his treason was not great, and Henry by sparing his life would not have shown undue clemency.

**BIRS NIMRUD**. See **BABYLON**, page 183.

**BISACCIA**, a city of Italy, in the Principato Ultraiore, 60 miles E. of Naples. It is a bishopric in conjunction with St Angelo, and contains 5342 inhabitants. Formerly it was the chief city in a principality belonging to the Pignatelli family, and it is believed to occupy the site of the ancient Romulea, a Samnite town of considerable size, which was captured by the Romans about 297 B.C.



**BISCAY**, or **VIZCAYA**, one of the three Basque provinces of Spain, with the title of Seignory. It is bounded on the N. by the bay to which it gives its name, E. by Guipuzcoa, S. by Alava, and W. by Santander. Its area is 845 square miles, and its population in 1867 was 183,098. The coastline, which extends from Ondarroa to a short distance to the east of Castro, is bold and rugged, and in some places is deeply indented. The only river of any size is the Nervion or Ibaizabal, on which Bilbao is situated; the others, which are numerous, are merely large mountain streams. The surface of the country is for the most part very mountainous, but at the same time is diversified with numerous narrow valleys and small plains. Some of the mountains are almost entirely composed of naked calcareous rock, but most of them are covered to their summits with forests of oaks, chestnuts, or pine trees. Holly and arbutus are also common, and furze and heath abound in the poorer parts. The province produces wheat, maize, barley, rye, flax, grapes, peaches, apples, and other fruits. The farms are generally small, and are for the most part tilled by manual labour. The wild boar, lynx, fox, and other wild animals, are found in the forests; and deer, rabbits, partridges, woodcocks, and other kinds of game are plentiful. Sheep and goats are the principal domestic animals. In minerals Biscay is very rich. Iron of the finest quality is found in almost every part, and forms a main article of export. The best mines are those of Somorostro, near the coast. The amount obtained in 1866 was about 80,000 tons. Lead, zinc, alum, and sulphur, are also present in smaller quantities; and marble, lime, and sandstone are abundant. The manufacture of the iron ore is the chief branch of industry; but porcelain, linens, copper and brass wares, ropes, and leather, are also produced. The fisheries are actively prosecuted along the coast by a hardy race of fishers, who were the first of their craft in Europe to pursue the whale, formerly abundant in the Bay of Biscay. Cod, bream, tunny, and anchovy are the principal fish taken. Bilbao is the capital of the province, with a population of 17,649; the other towns, Portugalete, Miravalles, Durango, and Orozco, are all very small. The principal ports, besides Portugalete, are Plencia, Bermeo, and Hea. After the fall of the Romans this Cantabrian province came successively into the hands of the Suevo, Franks, and Goths, and formed for some time an independent lordship. The legislative authority was exercised by the lord and a junto of popular representatives. The latter regularly assembled every two years, and on any emergency held an extraordinary meeting under an old tree at Guernica. Although incorporated with Spain, the Biscayans still maintain a republican form of administration, nominating their own governors and magistrates, regulating the amount of the taxes, and exercising various other privileges. They are a brave and active people, and their history is largely composed of exploits in defence of their liberties. For their linguistic and ethnographic affinities, see the article **BASQUE PROVINCES**. The name Biscay is not unfrequently employed as geographically equivalent to Basque, in that case including the three provinces of Biscay proper, Guipuzcoa, and Alava.

**BISCAY, BAY** or, in French the Golfe de Gascogne, and the Roman *Situs Aquitanicus*, an extensive gulf or bay of the Atlantic, enclosed by the northern coast of Spain and the western coast of France. It extends from the island of Ushant, on the coast of Finistère, to Cape Ortegal on the north of Galicia. In the Spanish portion of the bay the water is about 200 fathoms deep, while in the French portion it is only 20 fathoms. Navigation is impeded by strong westerly winds, and by Bannel's Current, which sets in from the west and sweeps along the southern and eastern shores sometimes at a rate of 27 miles

a day. The Loire, Charente, Gironde, and Adour, besides numerous smaller streams from the Spanish mountains, fall into the bay.

**BISCEGLIA**, perhaps the ancient *Natioium*, a fortified seaport of Italy, in the province of Terra di Bari, situated on a rocky promontory on the Adriatic, 21 miles W.N.W. of Bari. It is the seat of a bishopric, and has a cathedral, numerous churches and convents, and a theatre. Some ruins still exist of a hospital, founded by Bohemund for pilgrims to the Holy Land. Its harbour is only accessible to small vessels, and it has little trade. Being destitute of springs, it has numerous reservoirs for the collection of rain-water. Population, 21,371.

**BISCHWEILER**, a town of Alsace, 14 miles N. of Strasburg, on the railway from Hagenau. It has manufactures of woollen and linen stuffs, oil, soap, earthenware, &c., and some trade in hops, hemp, leather, and tobacco. Population in 1871, 9220, including that of Hanhoffen, which numbered 689.

**BISCUIT**. See **BAKING**, page 252.

**BISHOP**, the title of an ecclesiastical dignitary set over the presbyters and deacons at a very early period in the Christian church. The word is derived from the Saxon *bisceop*, which is a corruption of the Greek word *episcopos*, which signifies an "overlooker" or "overseer," and the churches in which the order of bishops is recognized as distinct from and superior to the order of presbyters are styled "Episcopal churches." The early history of the Episcopal order is obscure, but it would appear that the first bishops were established in the chief cities of Christendom, and each bishop had a certain territorial district placed under his superintendence, whence the city was termed the see (*sedes*) of the bishop, and the district his parish (*παροικία*), and subsequently his diocese (*διοκесьωσις*). In course of time the districts assigned to the first bishops became too populous, whereupon the clergy of each diocese, as the case might be, appear to have assembled and to have subdivided the diocese, and to have selected a second bishop, and so bishops and dioceses were multiplied, according to the wants of the churches, until it was thought expedient to reserve the right of erecting new bishoprics to provincial councils, and this reservation was made a rule of the church by a decree of the Council of Sardica. Meanwhile the bishops of the new sees had grouped themselves round the bishops of the more ancient sees, who exercised over them a certain spiritual authority as primates, and presided in their councils; and as some of the great cities in which the sees of the first bishops had been established were distinguished by the title of "metropolis," or mother-city, and were in fact the chief cities of civil provinces of the Roman empire, the bishops of those sees came to be distinguished by the title of metropolitan bishops, and exercised a superior authority in the councils of the church in proportion to the greater importance of their respective sees. This superior dignity of the metropolitan bishops over the others was formally recognized at the Council of Nicea as being in accordance with custom. Upon the establishment of Christianity as the religion of the Roman empire a coercive jurisdiction was engrafted on the spiritual superiority of the metropolitan, and the district over which the metropolitan exercised this jurisdiction was termed his province, the earliest ecclesiastical provinces being for the most part coterminous with the civil provinces of the empire. From the circumstance that there was no metropolitan city in Western Africa, the term metropolitan was never adopted in the Carthaginian Church, the senior bishop of that church being termed the primate, and having precedence and authority as such over the other bishops.

In the Church of Rome the Pope claims of right the

appointment of all the bishops; but the exercise of this right is modified by concordats with the sovereigns of the respective states. In France, since the concordat between Pope Leo X. and King Francis I., the sovereign has had the exclusive right of nominating the bishops, but the nomination is subject to the Pope's confirmation. In Austria (with the exception of four bishoprics), in Bavaria, in Spain, and in Portugal, the bishops are also nominated by the sovereign. In some countries the bishops are elected by the chapter of the cathedral church, as in Würtemberg, or by the bishops of the province, as in Ireland. In England, in the United States of America, and in Belgium, the Pope selects one out of a list of candidates submitted to him by the chapter. In all cases the bishop-nominate or the bishop-elect, as the case may be, has to obtain from the Holy See certain letters, entitled provisions, to authorize his consecration, and to recommend him to the protection of the sovereign and to the good offices of his metropolitan.

In the Church of Russia, after its separation from that of Constantinople, the right to elect a bishop was for some centuries vested in a synod of bishops, but by a regulation of the Emperor Peter the Great, the Holy Synod was restricted to recommend two persons to the sovereign for him to select one of them to be bishop. This regulation, however, is not always observed, and the sovereign, if he thinks fit, sets aside the list submitted to him by the Synod, and nominates of his own choice a person whom the Synod is obliged to elect. In Russia a diocese sometimes contains two capital cities, and the bishop has his title from both.

In the Church of the Levant, properly called the Greek Church, which is governed by the four patriarchs of Constantinople, Antioch, Jerusalem, and Alexandria, each patriarch has the right of confirming the election of the bishops within his patriarchate; but the firman or barat of the sultan is likewise necessary to give full authority to the bishops after their confirmation.

The bishops of the Church of England are twenty-eight in number, two of them being metropolitans, namely, Canterbury and York, who enjoy the more dignified title of archbishop, and have a special precedence assigned to them by law (see ARCHBISHOP). The twenty-six diocesan bishops, with the exception of the bishop of the Isle of Man, who is designated the bishop of Sodor and Man, are lords of parliament, and take precedence of the barons in the House of Lords; but the junior bishop for the time being is, by statute, disentitled from being summoned to parliament. From this disqualification the bishops of London, Durham, and Winchester are exempt. These three bishops have precedence over one another in the order in which their names are above mentioned, and they precede all the other bishops, the latter taking precedence of one another according to the date of their appointment. The junior bishop who has a seat in parliament acts as chaplain to the House of Lords.

In the Church of England the bishops exercise certain spiritual functions which are held not to be within the competence of the presbyters. They alone can administer the rite of confirmation to baptized persons, and they alone can ordain candidates for the sacred ministry. These functions the bishops exercise in virtue of their order, but they are also empowered by law to exercise a certain jurisdiction over all consecrated places and over all ordained persons. This jurisdiction they exercise for the most part through their consistorial courts, or through commissioners appointed under 3 and 4 Vict. c. 86, called the Church Discipline Act. The bishops also exercise a certain jurisdiction over marriages, inasmuch as they have by the canons of the Church of England a power of dispensing

with the proclamation of banns before marriage. These dispensations are termed marriage licences, and their legal validity is recognized by the Marriage Act, 4 Geo. IV. c. 76. The bishops had formerly jurisdiction over all questions touching the validity of marriages and the status of married persons, but this jurisdiction has been transferred from the consistorial courts of the bishops to a court of the Crown by 20 and 21 Vict. c. 85. They have in a similar manner been relieved of their jurisdiction in testamentary matters, and in matters of defamation and of brawling in churches; and the only jurisdiction which they continue to exercise over the general laity is with regard to their use of the churches and churchyards. The churchwardens, who are representative officers of the parishes, are also executive officers of the bishops in all matters touching the decency and order of the churches and of the churchyards, and they are responsible to the bishops for the due discharge of their duties; but the abolition of church-rates has relieved the churchwardens of the most onerous part of their duties, which was connected with the stewardship of the church funds of their parishes.

The bishops are still authorized by law to dedicate and set apart buildings for the solemnization of divine service, and grounds for the performance of burials, according to the rites and ceremonies of the Church of England; and such buildings and grounds, after they have been duly consecrated according to law, cannot be diverted to any secular purpose except under the authority of an Act of parliament.

The bishops of England have also jurisdiction to examine clerks who may be presented to benefices within their respective dioceses, and they are bound in each case by the 95th canon of 1604 to inquire and inform themselves of the sufficiency of each clerk within twenty-eight days, after which time, if they have not rejected him as insufficiently qualified, they are bound to institute him, or to license him, as the case may be, to the benefice, and thereupon to send their mandate to the archdeacon to induct him into the temporalities of the benefice. Where the bishop himself is patron of a benefice within his own diocese he is empowered to collate a clerk to it,—in other words, to confer it on the clerk without the latter being presented to him. Where the clerk himself is patron of the living, the bishop may institute him on his own petition. See BENEFICE.

The qualifications of a bishop of the Church of England are, that he should be a learned presbyter of at least thirty years of age, born in lawful matrimony, and of good life and behaviour. The mode of his appointment is regulated by 24 Henry VIII. c. 20. Upon the avoidance of a bishopric the Crown is authorized to issue to the dean and chapter of the cathedral church of the see a licence for them to proceed to the election of a bishop, accompanied by a letter missive containing the name of the person whom they are to elect. The dean and chapter are thereupon required, within twelve days, to elect the person so named by the Crown to be the bishop of the vacant see, failing which election the Crown is empowered to name, by letters patent under the Great Seal addressed to the archbishop and metropolitan of the province, such person to be bishop as the Crown shall think able and convenient. Upon the election being reported to the Crown, a mandate issues from the Crown to the archbishop and metropolitan, requesting him and commanding him to confirm the election, and to invest and consecrate the bishop-elect. Thereupon the archbishop issues a commission to his vicar-general to examine formally the process of the election of the bishop, and to supply by his authority all defects in matters of form, and to administer to the bishop-elect the oaths of allegiance, of supremacy, and of canonical obedience.

After this formal confirmation of the bishop's election has taken place, the archbishop, with the assistance of at least two bishops, proceeds to consecrate the bishop-elect. The most important part of the religious ceremony on this occasion consists in the imposition of hands, in other words, in the archbishop and the bishops placing their hands simultaneously upon the head of the bishop-elect kneeling before them, and in the name of the Holy Trinity committing to him his office of bishop; after which the archbishop delivers to him the Holy Bible and addresses to him a short admonition to preach faithfully the Word of God. The bishop is required afterwards, by statute, to do homage to the Crown, upon which he is put into possession of the temporalities of his see. In the case of the avoidance of the archbishopric of either province, the Crown sends a mandate to the archbishop of the other province to confirm and consecrate the archbishop-elect, and the practice is, for the most part, for the archbishop of the other province to send a commission to four or more bishops of the province of the archbishop-elect to confirm his election and to invest and consecrate him.

Doubts having been raised whether a bishop of the Church of England, being a lord of parliament, could resign his seat in the Upper House of parliament, although several precedents to that effect are on record, a statute of the realm (19 and 20 Vict. c. 115), which is confined to the case of the bishops of London and Durham, was passed in 1856, declaring that on the resignation of their sees being accepted by their respective metropolitans, those bishops should cease to sit as lords of parliament, and their sees should be filled up in the manner provided by law in the case of the avoidance of a bishopric. By a subsequent statute (32 and 33 Vict. c. 111), provision has been made for the case of an archbishop or bishop being permanently incapacitated by age or mental infirmity. If the archbishop or bishop is capable of executing an act of resignation, a representation may be made to the Crown, which is empowered to declare the see to be vacant, but if the archbishop or bishop should be incapacitated from intimating his desire to resign his bishopric, the Crown may grant a licence to the dean and chapter of the cathedral church of the diocese to appoint a bishop-coadjutor. This Act was to be in force for two years; it has been continued for three years more by 35 and 36 Vict. c. 40.

A peculiar institution of the Church of England, established by 26 Henry VIII. c. 14, having been long allowed to remain dormant, has been recently revived, under which every archbishop and bishop, being disposed to have a suffragan to assist him, may name two honest and discreet spiritual persons for the Crown to give to one of them the title, name, style, and dignity of a bishop of any one of twenty-six sees enumerated in the statute, as the Crown may think convenient. The Crown, having made choice of one of such persons, is empowered to present him by letters patent under the great seal to the metropolitan, requiring him to consecrate him to the same name, title, style, and dignity of a bishop; and the person so consecrated is thereupon entitled to exercise, under a commission from the bishop who has nominated him, such authority and jurisdiction, within the diocese of such bishop, as shall be given to him by the commission, and no other.

The first colonial bishopric of the Church of England was that of Nova Scotia, founded in 1787, since which time various colonial bishoprics have been established, some of which were constituted by letters patent of the Crown only, whilst others have been confirmed by acts of the imperial or colonial legislatures. With regard to those bishoprics which have been constituted by letters patent of the Crown only, where the bishopric has been established in a Crown colony, the bishop is legally entitled to exercise the jurisdiction conferred upon him by the letters patent; but where the bishopric has been established in a colony possessing at the time an indepen-

dent legislature, the bishop is not entitled to exercise such jurisdiction unless it has been confirmed to him by an imperial or colonial statute. The report of the judicial committee of the Privy Council in the case of the bishop of Natal (Moore's *Privy Council Reports*, N.S., III. p. 115) is an exposition of the law on this subject. On the other hand, where bishoprics have been constituted by letters patent of the Crown, in pursuance of imperial statutes, as was the case of the East Indian bishoprics, or where bishoprics constituted by letters patent have subsequently been confirmed or recognized by colonial statutes, the bishop's jurisdiction is complete; otherwise his authority is only pastoral or spiritual. The practice adopted by the Crown, since the decision of the judicial committee in the case of the bishop of Natal has revealed the invalidity of the letters patent granted to many colonial bishops, has been to grant licences to the archbishop of Canterbury to consecrate bishops for the colonies without any definite diocese, and without any authority to exercise coercive jurisdiction. The Crown has also revoked the letters patent erecting Gibraltar into a bishop's see, and the last appointed bishop has been consecrated under a licence from the Crown, and is a titular bishop, having only consensual authority in that colony. (T. T.)

BISHOP, SIR HENRY ROWLEY, musical composer, was born in London on the 18th November 1786. He received his artistic training from Francesco Bianchi, at whose instance, probably, he was employed to write his first work, the ballet of *Tamerlan et Bajazet*, produced at Covent Garden in 1806. This proved successful, and was followed within two years by several others, of which *Caractacus*, a pantomimic ballet, written for Drury Lane, may be named. In 1809 his first opera, *The Circassian's Bride*, was produced at Drury Lane; but by a singular misfortune the theatre was burned down after one performance, and the score of the work perished in the flames. His next work of importance, the opera of *The Maniac*, written for the Lyceum in 1810, established his reputation, and probably secured for him the appointment of composer for Covent Garden theatre. The numerous works—operas, barlettas, cantatas, incidental music to Shakespeare's plays, &c.—which he composed while in this position, are now in great part forgotten. The most successful were—*The Virgin of the Sun* (1812), *The Miller and his Men* (1813), *Guy Manservant* and *The Slave* (1816), *Maid Marian and Clari*, introducing the air of "Home, Sweet Home" (1822). His English adaptations, or rather mangled versions, of Morari's *Don Giovanni* and *Figaro*, and Rossini's *Il Barbiere* and *Guillaume Tell*, were certainly no true service to art. It seems almost incredible that a man of Bishop's undoubted genius should have been so misguided as to suppress the incomparable *Figaro* overture of Mozart in favour of one of his own. In 1824 Bishop was induced by Elliston to transfer his services from Covent Garden to the rival house in Drury Lane, for which he wrote with unusual care the opera of *Aladdin*, intended to compete with Weber's *Oberon*, commissioned by the other house. As was to be expected the result was a failure, and with *Aladdin* Bishop's career as an operatic composer may be said to close. On the formation of the Philharmonic Society (1813) Bishop was appointed one of the directors, and he took his turn as conductor of its concerts during the period when that office was held by different musicians in rotation. In 1841 he was appointed to the "Reid" chair of music in the University of Edinburgh, but he resigned the office in 1843. He was knighted by the queen in 1842, being the first musician who ever received that honour. In 1848 he succeeded Dr Crotch in the chair of music at Oxford. The music for the ode on the occasion of the installation of Lord Derby as chancellor of the university (1853) proved to be his last work. He died on the 30th April 1855 in impoverished circumstances, though few composers ever made more by their labour. Bishop's name will live in connection with his numerous glee, songs, and smaller compositions, rather than with his larger works, which are now seldom or never performed in their entirety. His Shake-

spear songs and glees are familiar favourites with all vocalists, and genius is discernible in not a few of them. His melodies are clear, flowing, appropriate, and often charming; and his harmony is always pure, simple, and sweet. He was a prominent example of both the strength and the weakness of the native English school, in which the name of Purcell alone stands unquestionably higher than his.

**BISHOP-AUCKLAND**, a market-town of England, in the county of Durham, 11 miles south-west of the city of Durham. It is beautifully situated on an eminence near the confluence of the Wear and the Gaunless; its streets are well paved and lighted, and there is a good supply of water. The parish church is 1 mile distant, at Auckland St Andrews, but there are several churches and chapels in the town. The town-house, which dates from 1863, is a handsome building, with a tower 100 feet in height; and the palace of the bishop of Durham, which stands at the north-east end of the town, is a spacious and splendid though irregular pile. The site of the palace was first chosen by Bishop Anthony Beck, in the time of Edward I. The present building covers about 5 acres, and is surrounded by a park of 800 acres. The principal industrial establishments are cotton-factories and engineering works; and in the neighbourhood of the town are several coal-mines. Population of local board district in 1871, 8736.

**BISHOP-STORTFORD**, a market-town of England, on the eastern border of Herts, 11 miles E.N.E. of Hertford, and 32 miles by railway from London. It is situated on both sides of the River Stort, a tributary of the Lea, and has thus direct water communication with the metropolis. The parish church of St Michael's, a fine building with a spire, dates from the reign of Henry VI., but was partly rebuilt in 1820. A town-house, a corn exchange, a union workhouse, a high school, a collegiate school, and a diocesan training school, are among the chief buildings; and there are also public baths, libraries, and banks. The industrial establishments comprise a brewery, malt-houses, coach-works, lime-kilns, and a foundry; and the trade consists chiefly in grain and malt. Stortford was in existence before the Norman conquest; and its castle, known as Waytemore Castle, was presented by William the Conqueror to Maurice, bishop of London, and his successors. The building was, however, demolished by King John, and only a few ruins remain. Sir H. Chauncey, the historian of Hertfordshire, and Hoole, the translator of Tasso, were both natives of Stortford. Population of the parish in 1871, 6250.

**BISHOP-WEARMOUTH**, a township of Durham in England, now incorporated in the parliamentary borough of Sunderland. See **SUNDERLAND**.

**BISKARA**, or **BISKRA**, a town of Algeria, in the province of Constantine, and the most important military post of the Sahara. It lies on the south side of the Aures Mountains, in a fertile district, watered by the Wadi Biskra. The streets of the town are broad, and its houses are for the most part built of brick, one story high, and with terraced roofs. Among the principal buildings are the fort of St Germain, the caravanserai, the hospital, and the barracks. A large caravan trade between the Sahara and the Tell passes through the town; iron, limestone, and saltpetre are obtained in the neighbourhood, and the surrounding country yields abundance of valuable dates. The chief articles of manufacture are burnous and carpets. An acclimatization garden has been established at Beni-Morra by the French, who first made themselves masters of Biskara in 1844. Population in 1872, 7367.

**BISMUTH**. This metal appears to have been unknown to the older metallurgical writers, it having been first noticed by Agricola, who speaks of it as a form of lead, and describes the method of separating it from its associ-

ated minerals by lixivation. Mathesius in his *Bergpostilla*, written between 1553-1562, describes it as white like pyrites, and occasionally cubical like marcasite, easily overcome by the fire when melted, and running together with the tin, which thereby is rendered brittle and unsound,—the last remark referring to its occurrence with tin ores in Saxony. It was considered by the miners as a hopeful indication of silver, and even in certain cases is said to have been transformed gradually into that metal, as portions of the ore which had lain for some time exposed were found afterwards to be partly or wholly changed into silver. This remark is interesting, as the same belief seems to have come up again in our own time. The name *Wismuth* is a miner's term, whose origin is completely lost; but Mathesius assigns it a fanciful derivation from *Wisse = Wise*, a meadow, because in the mine it is found covered with flowers or incrustations of various colours, resembling a meadow covered with brilliantly coloured flowers,—an obvious confusion with the minerals known as nickel and cobalt bloom, derived from the oxidation of arsenides of nickel and cobalt, with which native-bismuth is commonly associated in Saxony. It is to this association with cobalt and arsenic that must be ascribed the statements that its principal use was to produce a blue colour, and that it gave off a very poisonous furnace smoke. The chief use of the metal at that time seems to have been by pewterers, who added it to their alloy in small proportions for the purpose of rendering their wares hard and sonorous when struck.

The principal minerals containing bismuth are:—1. Native bismuth, essentially *the pure metal*, having all the properties described below. This, the most important ore, occurs in connection with nickel and cobalt ores at Schneeberg, Saxony, at Wheal Sparrow in Cornwall, similarly associated, and with tin ores in the mines of the St Just district. It is also found in some quantity in Bolivia. 2. Tetradymite, or telluric bismuth, a compound in variable proportions with the isomorphous element tellurium. This contains from 60 to 80 per cent. of bismuth, 15 to 35 per cent. of tellurium, and from 3 to 5 per cent. of sulphur. It occurs usually in association with gold ores; the principal localities are Schemnitz and Retschany in Hungary, the gold mining district of Virginia and North Carolina, California; and other western states of America. It was also found at the Merionethshire gold mines as a rarity. 3. Bismuth silver, found at Schapbach in Baden, and near Copiapo in Chili. The mineral from the former locality contains 27 of bismuth to 15 of silver, with some lead and sulphur, and a little iron; and that from the latter 60 of silver to 10 of bismuth, the remainder being copper and arsenic. 4. Bismuthine, or bismuth glance, a sulphide of bismuth, of the composition  $\text{Bi}_2\text{S}_3$ , containing 81.6 per cent. bismuth and 18.4 per cent. sulphur, crystallizing in acicular rhombic prisms isomorphous with antimony glance. It occurs with tin ore at Botallack and other mines near St Just in Cornwall, and in the Saxon localities given above. 5. Bismuth ochre, an earthy oxide of bismuth, containing 90 per cent. bismuth and 10 per cent. oxygen, which is derived from the oxidation both of the native metal and of the sulphide. 6. Bismutite, a hydrated carbonate of bismuth, containing 90 per cent. bismuth oxide, 6.56 per cent. carbonic acid, and 3.44 per cent. water, another product of atmospheric action upon native bismuth. It is found principally in Saxony and South Carolina. Besides the above there is also a silicate described, but this is an exceedingly rare mineral, as is also Hypochlorite, a hydrated silicate mixed with phosphate of alumina. Practically the only ore is the native metal, and of late years, from the supply not keeping pace with the demand, the price has risen very considerably. The bismuth of com-

meres usually contains both gold and silver, often in considerable quantity, which circumstance has probably given rise to the story current about its transmutation into these metals.

Bismuth may be readily obtained in crystals by pouring it when melted into a heated iron ladle, and cooling it until a crust is formed on the surface, which must then be pierced by a red-hot iron rod, and the liquid metal poured off. The solidified portion adhering to the ladle is found to be covered with hopper-shaped crystals, which are usually beautifully irised, owing to the formation of a thin film of oxide on the surface, showing the colours of thin plates. This colouring is only obtained when the metal is quite free from arsenic. It may be purified by melting with about 10 per cent. of nitre, and keeping it constantly stirred at a temperature not much above its melting point, whereby the more oxidizable metals are removed, and form a slag at the surface. Another method of purifying it from arsenic is by fusing it with from 3 to 5 per cent. of zinc, covering the surface with charcoal to prevent oxidation of the zinc, which takes off the whole of the arsenic, and is subsequently removed by treatment with hydrochloric acid, the purified bismuth remaining insoluble. When prepared by any of these processes, Bismuth is a hard, brittle metal, and the fracture is highly crystalline and white, with a perceptible red tinge by reflected light. The crystalline form is rhombohedral, the angle of the primary rhombohedron being  $87^{\circ} 40'$ , or very close to a cube. The specific gravity is 9.88, but when subjected to great pressure the density is reduced to 9.8. The melting point is  $264^{\circ} \text{C}$ . ( $507^{\circ} \text{Fabr}$ .) (Kudberg), or  $268^{\circ} 3$  ( $515^{\circ}$ ) (Riemedijk). Like water it may be cooled  $6^{\circ}$  or  $7^{\circ} \text{C}$ . below its freezing point; but when solidification sets in the temperature rises to  $480^{\circ} \text{Fabr}$ ., and continues until the mass is completely solidified. Like ice it expands about  $\frac{1}{4}$  of its volume in solidification, a property which is communicated to its alloys, rendering them valuable for taking casts of incised or relief surfaces for reproduction, as printing-blocks by electrotype or other processes. It may be distilled by heating to a higher temperature in hydrogen. Despretz volatilised it by subjecting it to the current from 600 Bunsen elements. The spectrum of the vapour in the voltaic arc shows numerous brilliant green lines, one strong and one fainter line on the red, and a faint line on the orange field (Masson). The coefficient of expansion by heat is .001841, calorific conductivity 81, silver being 1000 (Calvert and Johnson), and specific heat 0.0806 (Kopp). The electric conductivity is 1.19 at  $14^{\circ} \text{C}$ ., silver being 100 at  $0^{\circ}$  (Matthiessen). According to Mattiæd the conductivity varies in the crystals according to the direction of the cleavages. It is the most strongly diamagnetic of all metals.

The atomic weight is 208 (Schnneider) or 210 (Dumas). Like phosphorus and arsenic it is both triatomic and pentatomic, the latter state being represented only by a very unstable acid; there are also several diatomic compounds, including  $\text{BiBr}_2$ ,  $\text{BiCl}_2$ , and  $\text{BiI}_2$ . The triatomic compounds are the most numerous and stable. Unlike the elements chemically similar,—phosphorus, tellurium, arsenic, antimony, &c.,—it does not form a gaseous compound with hydrogen. Bismuth does not change in dry air, but in moist air it oxidises superficially, and by long exposure may be converted into carbonate. When melted at a red heat it oxidises, and the oxide (whose formula is  $\text{Bi}_2\text{O}_3$ ), by a higher temperature, melts to a glassy substance, in which property it resembles lead, the oxide, like litharge, exerting a very corrosive action upon earthen crucibles, or substances containing silica, at a red heat. At a red-white heat it slowly decomposes water with the production of oxide. The higher oxide  $\text{Bi}_2\text{O}_5$  corresponds to arsenic acid; it is a very unstable compound, and of no practical value. An intermediate oxide is known which is generally regarded as a compound of the other two,  $\text{Bi}_2\text{O}_4$ ,  $\text{Bi}_2\text{O}_3$ . Bismuth unites directly with chlorine, bromine, and iodine, and when fused with sulphur forms a sulphide of the form  $\text{Bi}_2\text{S}_3$ , corresponding to bismuth glance, and isomorphous with the corresponding sulphide of antimony. The same sulphide is produced when sulphuretted hydrogen is passed through a solution containing bismuth.

Bismuth is but slightly acted upon by hydrochloric or sulphuric acids in the cold; but the latter dissolves it more readily when heated. The best solvent is nitric acid, which attacks it readily, producing a nitrate which crystallizes from the concentrated solution in colourless transparent crystals belonging to the triatomic system, whose composition is  $\text{Bi}_2\text{NO}_3 \cdot 5\text{H}_2\text{O}$ . These crystals are soluble in nitric acid, but, like all neutral salts of the metal, are decomposed by water, with the formation of an insoluble basic nitrate and an acid liquor. These basic salts are very numerous and complex in constitution, the most important one being that represented by the formula  $\text{Bi}_2\text{NO}_3 \cdot \text{H}_2\text{O}$ , which is known as pearl-white, *blanc de fer*. This, which is largely used as a medicine, is prepared by adding to a concentrated solution of bismuth dissolved in nitric acid from 40 to 50 times its weight of water, which precipitates a considerable proportion in the form of a white powder; the remainder, which is retained by the acid liquor, may be separated by neutralizing the excess of acid with ammonia, when a rather

more acid salt than the first precipitate is obtained. Under the name of pearl-white the sub-nitrate is used as a cosmetic, but it has the disadvantage of being readily blackened by sulphuretted hydrogen.

Bismuth unites readily with other metals, the alloys being remarkable for their ready fusibility, and by their property of expanding on solidification. An alloy with potassium is obtained by calcining 20 parts of bismuth with 16 parts of cream of tartar in a crucible, and heating the mixture to a very strong red heat. On cooling, a button of metal is found, of a silvery white colour and lamellar fracture, which fuses easily, and remains for a long time in a pasty condition before solidification; it is brittle, can be easily powdered, and is readily decomposed by water. The alloy with sodium is obtained in a similar manner, with a sodic tartrate. With silver, gold, and metals of the platinum group, bismuth forms brittle alloys. With mercury it forms a liquid amalgam; but when equal weights of the two metals are heated together, there is a separation on cooling of octahedral crystals, which may be a solid amalgam. The copper alloy is brittle, and of a pale red colour. The ternary alloys of lead, tin, and bismuth, are the most interesting of these compounds, from their low fusibility, which is much below that of any of the components taken separately. This property was known to Sir Isaac Newton; the alloy named after him, Newton's fusible metal, melts at  $94^{\circ} 5 \text{C}$ . ( $202^{\circ} \text{Fabr}$ .); it contains 8 parts of bismuth, 5 of lead, and 3 of tin. Darcey's fusible metal, containing 2 of bismuth, 1 of lead, and 1 of tin, melts at  $95^{\circ}$  ( $199^{\circ} 4 \text{Fabr}$ .). Another, with 5 of bismuth, 2 of tin, and 3 of lead, melts at  $91^{\circ} 6$  ( $197^{\circ} \text{Fabr}$ .) Rose's fusible metal, containing 420 parts of bismuth, 286 of lead, and 207 of tin, a composition corresponding to the formula  $\text{Bi}_2\text{Sn}_3\text{Pb}$ , fuses below  $100^{\circ}$  ( $212^{\circ}$ ), and remains pasty for a considerable range of temperature below that point. The expansion of this alloy by heat proceeds regularly from  $0^{\circ}$  to  $35^{\circ} \text{C}$ ., but by further heating it contracts up to  $55^{\circ}$ , from which point up to  $80^{\circ}$  the rate of expansion is more rapid than at the lower temperatures. Above  $80^{\circ}$  the normal rate is resumed. The fusibility of these alloys is increased by an addition of cadmium. Thus Wood's fusible metal, containing 1 to 2 parts of cadmium, 3 of tin, 2 of lead, and 7 to 8 of bismuth, melts between  $66^{\circ}$  and  $71^{\circ} \text{C}$ . Another, described by Lipowitz, containing 8 parts of lead, 15 of bismuth, 4 of tin, and 3 of cadmium, is silvery white, and has a specific gravity of 9.4. It softens at about  $55^{\circ}$ , and is completely liquid at a little above  $60^{\circ}$ .

Fusible alloys containing bismuth are used to some extent as safety plugs for steam boilers, as an accessory to the safety-valve,—a hole in the boiler being plugged by a disc of the metal, which in the event of the temperature of the water rising through excessive pressure is melted, and the steam passes through the aperture in the same manner as through an opened safety-valve. It is found, however, that this method is not trustworthy, owing to the ligation of the more fusible components of the mass, when subjected to continued heating near but below the melting point, leaving a more refractory alloy behind. The alloy known as Britannia metal, consisting chiefly of tin, antimony, and copper, often contains a little bismuth.

In analysis bismuth is usually separated from solution as carbonate by precipitation with carbonate of ammonia, which is then converted into oxide by calcination at a gentle heat, in which form it is weighed and estimated. The oxide  $\text{Bi}_2\text{O}_3$  contains 89.74 per cent. of bismuth. It is readily precipitated as sulphide by passing sulphuretted hydrogen through an acid solution, but the precipitate cannot be weighed, as it usually contains an excess of sulphur, and cannot be completely freed from water below  $200^{\circ}$ , so that it must be redissolved in nitric acid and precipitated as carbonate as above described. It may be precipitated in the metallic state by zinc, cadmium, copper, iron, or tin. A plate of copper introduced into a boiling solution of a bismuth salt, even when very weak, is readily covered with a coating of the reduced metal of a steel-gray colour.

Bismuth may be employed instead of lead for the assay of gold and silver by cupellation, as the melted oxide is absorbed by bone ash in exactly the same manner as litharge.

The separation of bismuth from solutions in which it is associated with silver, copper, mercury, cadmium, and lead, may be effected by cyanide of potassium; by digesting the solution with an excess of this reagent the cyanides of bismuth and lead remain in the insoluble portion, while those of the other metals are contained in the filtrate. On redissolving, the lead may be precipitated as sulphate, or by hydrochloric acid and alcohol, which renders the chloride of lead insoluble. The bismuth is finally precipitated from the filtrate by sulphuretted hydrogen. From copper it is readily separated by carbonate of ammonia, bismuth being precipitated, and copper remaining in solution. Another method is by heating in a current of chlorine, when chloride of bismuth is volatilised.

The metallurgical processes for the extraction of bismuth are very simple, being mainly comprised in ligation out of contact with the air, and subsequent fusion of the ligated product of the first operation. At Schneeberg, in Saxony, the ligation is effected in cast-iron tubes placed transversely over a fire-grate which runs the whole length of the furnace. The tubes are inclined, the highest

and being open for charging, and the lower stopped, with the exception of a small hole for the passage of the separated metal, which is received in a cast-iron pot placed in front and heated with charcoal. The charge, about half a cwt. of ore, broken into pieces about half inch cube, occupies about half of the length and rather more than half the area of each tube. When all the tubes are charged the upper ends are stopped by sheet-iron doors, and heat is applied by means of a wood fire upon the grate. The liquid metal soon commences to flow, and is received in the pots in front. If the flow ceases through any obstruction the passage is cleared by an iron rod introduced through the aperture at the lower end. When the operation, which usually lasts about an hour, has terminated, the residues in the tubes are removed and thrown into a water trough placed behind the furnace on the charging side, and a fresh supply of ore is introduced. The bismuth collected in the pots is ladled out and cast into ingots of from 25 to 50 lb weight. In a furnace containing 11 tubes about 20 cwt. of ore may be heated daily with a consumption of 63 cubic feet of wood. In Plattner's modification the furnace is of the reverberatory form, the tubes being placed with their inclined axes in the direction of the flame, an arrangement which allows the use of a smaller fire-grate and a proportionate saving of fuel. At Joachimsthal, ores containing from 10 to 80 per cent. of bismuth are heated in a finely-ground state with scrap-iron, carbonate of soda, and a little lime and fluor-spar in earthen crucibles, which are heated until the mixture is completely fused, when the contents are poured into iron moulds of a sugar-loaf form. The bismuth collects in the point of the mould, and is covered with a cake of spates, containing all the nickel and cobalt of the ore with about 2 per cent. of bismuth, which is reserved for further treatment; the slag filling the upper part of the mould is thrown away. If the bismuth is sufficiently rich in silver it is cupelled, and the oxide formed is subsequently reduced or revived by fusion with carbon. When argentiferous lead containing bismuth is subjected to cupellation the former metal is oxidized more rapidly than the latter, which accumulates to such an extent that it may often form a notable proportion of the litharge produced towards the end of the process, although not existing in sufficient amount to be appreciable by the ordinary processes of analysis in the original lead. This property has recently been utilised to recover a small quantity of bismuth existing in the silver ores smelted at Freiberg. The last portion of the litharge, and the hearth or test bottom from the silver refining furnace, are heated in quantities of 80 or 100 lb in earthenware pots with hydrochloric acid until complete solution of the bismuth oxide takes place, the proportion of acid and water being regulated to prevent the formation of insoluble salts. When the liquid is clear it is siphoned off to the precipitating tub, where it is thrown down as an insoluble oxychloride by the addition of a large quantity of water. By redissolving and reprecipitating, a purer material is obtained, which is then dried and reduced by fusion in iron crucibles with carbonate of soda and charcoal. The production of bismuth annually in Saxony is about 22 tons, and in Austria about 17 cwt.

The principal properties and reactions of bismuth and its compounds were described in 1789 by Pott, who gave a summary of the information contained in the earlier writers. Our more exact knowledge of the subject is due to Neumann, Hellot, Geoffroy (1763), John Davy (1812), Lagerhjelm (1815), Stromeyer, and, more recently, Schneider and Nickle. (H. B.)

**BISON**, a genus of Ruminant Mammals belonging to the family *Bovidae*, and comprising two widely separated species—the European and American Bisons. They are distinguished from other bovine animals by the greater breadth and convexity of their foreheads, superior length of limb, and the longer spinal processes of the dorsal vertebrae, which, with the powerful muscles attached for the support of the massive head, form a protuberance or hump on the shoulders. The bisons have also fourteen pairs of ribs, while the common ox has only thirteen. The forehead and neck of both species are covered with long, shaggy hair of a dark brown colour; and in winter the whole of the neck, shoulders, and hump are similarly clothed, so as to form a "curly felted mane." This mane in the European species disappears in summer; but in the American Bison it is to a considerable extent persistent. The European Bison (*Bison bonassus*), or Aurochs of the Germans, is the largest of existing European quadrupeds, measuring about 10 feet long, exclusive of the tail, and standing nearly 6 feet high. Formerly it was abundant throughout Europe, as is proved by its fossil remains found on the Continent and in England, associated with those of the extinct mammoth and rhinoceros. These

remains, while indicating larger proportions in the ancient aurochs than in those now living, do not, in Professor Owen's opinion, exhibit any satisfactory specific distinction. Caesar mentions the aurochs as abounding, along with the now extinct *Bos primigenius*, in the forests of Germany and Belgium, where it appears to have been occasionally captured, and afterwards exhibited alive in the Roman amphitheatres. At that period, and long after, it seems to have been common throughout Central Europe, the Caucasus, and the Carpathian Mountains. It is now only found in one of the forests of Lithuania, where it is saved from immediate extinction by the protection of the emperor of Russia, but notwithstanding this it is gradually dying out. Many years ago the Lithuanian bisons numbered over 1000, but by the year 1872 they had diminished to 528, and all attempts to domesticate them have failed. The aurochs feeds on grass and the bark of young trees. The American Bison (*Bison americanus*) has its home on the eastern slopes of the Rocky Mountains, being seldom found to the west of these, and rarely to the east of the Appalachian range. Northwards it extends to lat. 63°, and southward as far as New Mexico. Those bisons or buffaloes, as the settlers call them, roam in enormous herds over the western prairies in quest of fresh pastures, being specially fond of the tender grass that springs up after a prairie fire. The two sexes live in separate herds during the greater part of the year, although one or two aged bulls, it is said, always accompany the females. During the rutting season when the sexes come together, the bulls engage in fierce fights among themselves, and at such seasons it is highly dangerous to approach them. At other times they are shy, and retreat before man; but when wounded they become furious, and then all the dexterity of the practised hunter is needed to make good his retreat. The Indians capture them in various ways; by hunting on horseback, and shooting them with bows and arrows, or with fire-arms; by snaring them within immense enclosures of snow, which the bisons are unable to overleap; or by attracting the herd towards a precipice, and then setting it in motion from behind, so that those in front are pushed irresistibly forward and over. The American Bison, though still found in considerable numbers, is rapidly diminishing before the advance of the white settler; and should man in the meantime not succeed in domesticating it, it will probably ere long share the fate which threatens its European congener. To the Indian the bison has hitherto been indispensable as an article of food, and for the many useful purposes to which its horns, skin, and hair are applied. Its hide forms an excellent fur wrapper; its great value in this respect was proved during the Crimean war.

**BITHYNIA** (*Bithynia*), a province in the N.W. of Asia-Minor, adjoining the Propontis, the Thracian Bosphorus, and the Euxine. According to Strabo it was bounded on the east by the River Sangarius; but the more commonly received division extended it as far as the Parthenius, which separated it from Paphlagonia, thus comprising the district on the sea-coast between these two rivers, which was inhabited by the Mariandyni. Towards the west and south-west it was limited by the River Rhyndacus, which separated it from Mysia; and on the south it adjoined the portion of Phrygia called Phrygia Epictetus, and a part of Galatia. The territory thus defined is in great part occupied by mountains and forests, but has valleys and districts near the sea-coast of great fertility. The most important of the mountain ranges is that known as the Mysian Olympus—from its proximity to that province, though properly included within the limits of Bithynia—which rises to a height of about 6400 feet. It towers in a commanding manner above the city of Broussa, while it forms a conspicuous object as seen from Constantinople, at

a distance of 70 miles. Its summits are covered with snow for a great part of the year. Eastward of this the range now called Ala-Dagh extends for above 100 miles from the River Sangarius to the confines of Paphlagonia. It adjoins throughout its course the frontiers of Phrygia and Galatia, and rises to a height of from 6000 to 7000 feet. Both of these ranges belong to that border of mountains which bounds the great table-land of Asia Minor through a great part of its extent. The country between them and the sea-coast is for the most part occupied by subordinate mountain chains, which may be regarded as underfalls or offshoots of the more lofty mountain ranges of the interior. These constitute a very rugged and broken country, covered with extensive forests, and traversed by very few lines of route, so that it is still very imperfectly known. But the broad tract which projects towards the west as far as the shores of the Bosphorus, though hilly and covered with forests, so as to be termed by the Turks Aghatch Denizî, or "The Ocean of Trees," is not traversed by anything like a mountain chain.

The western coast of Bithynia, where it adjoins the Propontis or Sea of Marmora, is indented by two deep gulfs or inlets—the northernmost, now called the Gulf of Ismid, anciently known as the Gulf of Astacus, penetrating to a distance of between 40 and 50 miles into the interior, as far as the town of Ismid, the ancient Nicomedia, which is separated by an isthmus of only about 25 miles from the Black Sea. The next, known in ancient times as the Gulf of Cius, now called the Gulf of Moudania or Gemlik, extends to about 25 miles. At its extremity is situated the small town of Gemlik, on the site of the ancient Cius, at the mouth of a valley, through which it communicated with the inland lake of Isnik, on which was situated the flourishing city of Nicæa.

According to the general testimony of ancient authors (Herodotus, Xenophon, Strabo, &c.), the Bithynians were a tribe of Thracian origin who had migrated into Asia by crossing the Bosphorus. The existence of a tribe called Thyni in Thrace is well attested, and the two cognate tribes of the Thyni and Bithyni appear to have settled simultaneously in the adjoining parts of Asia, where they expelled or subdued the previously existing races of the Mysians, Caucones, and other petty tribes, the Mariandyni alone maintaining themselves in the north-eastern part of the country. Herodotus mentions the two tribes, the Thyni and Bithyni, as existing side by side; but ultimately the latter people must have become the more important, so as to give name to the whole country. They were first subdued by Croesus, and incorporated with the Lydian monarchy, together with which they soon after fell under the dominion of Persia (546 B.C.) During the Persian empire they were included in the satrapy of Phrygia, which comprised all the countries up to the Hellespont and Bosphorus. But even before the conquest by Alexander some obscure native chiefs appear to have asserted their independence in the mountains of Bithynia, and successfully maintained it under two native princes named Bas and Zipotes, the last of whom transmitted his power to his son Nicomedes I., who was the first to assume the title of king. He became the founder of the city of Nicomedia, which soon rose to great prosperity and opulence; and during his long reign (278–250 B.C.), as well as those of his successors, Prusias I., Prusias II., and Nicomedes II. (149–91 B.C.), the kingdom of Bithynia held a considerable place among the minor monarchies of Asia. But the last king, Nicomedes III., was unable to maintain himself against the increasing power of his neighbour Mithridates, king of Pontus; and although restored to his throne by the interposition of the Roman Senate, at his death, in 74 B.C., he bequeathed his kingdom by will to the

Romans. Bithynia was now reduced into the form of a Roman province; but its limits were frequently varied, and it was commonly united for administrative purposes with the neighbouring province of Pontus, extending along the southern shore of the Black Sea as far as Trapezus or Trebizond. This was the state of things in the time of Trajan, when the younger Pliny was appointed governor of the combined provinces (103–105 A.D.), a circumstance to which we are indebted for much valuable information concerning the Roman provincial administration. Under the Byzantine empire Bithynia was again divided into two provinces, separated by the River Sangarius, to the westernmost of which the name of Bithynia was restricted.

The most important cities of Bithynia in ancient times were Nicomedia and Nicæa, which disputed with one another the rank of its capital. Both of these were founded after the time of Alexander the Great; but at a much earlier period the Greeks had established on the coast the colonies of Cius (afterwards named Prusias), on the site of the modern Gemlik; Chalcedon, at the entrance of the Bosphorus, nearly opposite Constantinople; and Heraclea, surnamed Pontica, on the coast of the Euxine, about 120 miles east of the Bosphorus. All these rose to be flourishing and important places of trade. Prusa, at the foot of Mount Olympus, which was founded by Prusias, was also a considerable town under the Roman empire, but did not attain in ancient times to anything like the importance enjoyed by the modern city of Broussa, which became the capital of the Ottoman Turks before the conquest of Constantinople, and is still (after Smyrna) the second city of Asia Minor. The only other places of importance at the present day are Ismid (Nicomedia) and Scutari, which, from its position on the Bosphorus, may be considered as a mere suburb of Constantinople.

The natural resources of Bithynia are still very imperfectly developed. Its mountains are covered with vast forests, which would furnish an almost inexhaustible supply of timber, if rendered accessible by roads. Coal also is known to exist in the neighbourhood of Ereki (Heraclea), but is not worked to any extent. The valleys which open towards the Black Sea abound in fruit trees of all kinds, while the valley of the Sangarius and the plains near Broussa and Isnik (Nicæa) are fertile and well cultivated. Extensive plantations of mulberry trees supply the silk for which Broussa has long been celebrated, and which is manufactured there on a large scale.

The principal rivers of Bithynia are the Sangarius, still called the Sakaria, which traverses the province from S. to N.; the Rhyndacus, which forms the boundary that separated it from Mysia; the Billeus (Filyas), which rises in the chain of the Ala-Dagh, about 150 miles from the sea, and after flowing by the town of Boli (the ancient Claudiopolis) falls into the Euxine, close to the ruins of the ancient Tium, about 40 miles N.E. of Heraclea. It has a course of more than 100 miles. The Parthenius (now called the Bartan), which forms the boundary of the province towards the E., is a much less considerable stream. (R. H. R.)

BITONTO, a city and bishop's see, in the province of Bari, in South Italy, on the great road from Foggia to Bari, about 12 miles from the latter town. Its cathedral, dedicated to St Valentine, is a fine building in the Italo-Gothic style; and it possesses a theological seminary, a large orphan asylum, and a hospital. The inhabitants maintain an active trade, and have extensive manufactures of olive oil. Their principal export is an excellent wine known as Zagarella. Bitonto, or Butantum, seems from its coins to have been a place of some importance at an early period, but it makes no appearance in ancient history. In the Middle Ages its *Accademia degli Inflammati* obtained

considerable fame. In 1735 it was the scene of a severe battle, in which the Austrians were defeated by the Spaniards under Mortemar, in whose honour Philip V. caused a pyramid to be erected on the spot. Population in 1871, 24,978.

**BITTSCH** (French, **BITOHE**), formerly **KALTENHAUSEN**, a town and fortress in German Lorraine, on the River Horn, at the foot of the northern slope of the Vosges, between Hagenau and Saargemund. It was originally a countship in the possession of the counts of Alsace and Flanders, but was bestowed by Frederick III. on the dukes of Lorraine, and at length passed with that duchy to France in 1738. After that date it rapidly increased, and its citadel, which had been constructed by Vauban on the site of the ducal palace, was restored and strengthened. The attack upon it by the Prussians in 1793 was repulsed, and although the Bavarians occupied the town in 1815 and 1818, they did not get possession of the fort. In the war of 1870 it was blockaded by the Germans in vain, and only surrendered in 1871, after the campaign was over. A large part of the fortification is excavated in the red-sandstone rock, and rendered bomb-proof; while a supply of water is secured to the garrison by the possession of a deep well in the interior. The inhabitants of the town, who in 1871 numbered 3047, manufacture watch-glasses and matches, and carry on a trade in grain, cattle, wood, and peats.

**BITTERN**, a genus of Wading Birds, belonging to the family *Ardeidae*, comprising several species closely allied to the Herons, from which they differ chiefly in their shorter neck, the back of which is covered with down, and the front with long feathers, which can be raised at pleasure. They are solitary birds, frequenting countries possessing extensive swamps and marshy grounds, remaining at rest by day, concealed among the reeds and rushes of their haunts, and seeking their food, which consists of fish, reptiles, insects, and small quadrupeds, in the twilight. The Common Bittern (*Botaurus stellaris*) is nearly as large as the heron, and is widely distributed over the eastern hemisphere. Formerly it was common in Britain, but the extensive drainage of late years has greatly diminished its numbers, and it is now a permanent resident only in the fen districts of England. The bittern in the days of falconry was strictly preserved, and afforded excellent sport. It sits crouching on the ground during the day, with its bill pointing in the air, a position from which it is not easily roused, and even when it takes wing, its flight is neither swift nor long sustained. When wounded it requires to be approached with caution, as it will then attack either man or dog with its long sharp bill and its acute claws. It builds a rude nest among the reeds and flags, out of the materials which surround it, and the female lays four or five eggs of a uniform dusky brown. During the breeding season it utters a booming noise, from which it probably derives its generic name, *Botaurus*, and which has made it in many places an object of superstitious dread. Its plumage for the most part is of a pale buff colour, rayed and speckled with black and reddish brown. The American Bittern (*Botaurus lentiginosus*) is somewhat smaller than the European species, and is found throughout the central and southern portions of North America, where it forms an article of food. It also occurs in Britain as an occasional straggler.

**BITTERS**, an aromatized alcoholic beverage, so named originally in the United States, where it was first used on account of its flavour and tonic influence. The drink by itself, or as an addition to unflavoured spirits, is used with considerable frequency in Europe, and especially in France it has come to be favourably regarded as a substitute for the insidious and deleterious absinthe. In the

year 1867 the daily consumption of bitters in Paris alone had reached 4000 litres. The preparation of bitters in Europe was at first a *specialité* of the Dutch, and Dutch bitters are the staple used in Great Britain. A considerable variety of recipes are in use for the preparation of Dutch bitters, but generally gentian root is the leading bitter ingredient in the beverages. The following is given as the composition of brandy bitters:—Gentian root, 4 oz.; orange peel, 5 oz.; cassia bark, 2 oz.; cardamoms, 1 oz.; and proof spirits, 1 gallon, coloured with  $\frac{1}{4}$  oz. of cochineal. Bitters prepared in the great French cities—Bordeaux, Rouen, Havre, Paris, &c.—contain extracts of gentian root, bitter orange peel, and orange flowers, with a proportion of sugar, and possess an alcoholic strength of about 40°

**BITUMEN**. See **ASPHALT**, vol. ii. p. 715.

**BIZERTA**, or **BEZERT**, a seaport of North Africa, in Tunis, 38 miles from the capital, on a gulf or salt lake of the same name, which communicates with a shallow fresh water lake in the interior, formerly called Sissara, and now the lake of Gebel Ishkel. It occupies the site of the ancient Tyrian colony Hippo Zaritus, the harbour of which, by means of a specious pier, protecting it from the north-east wind, was rendered one of the safest and finest on this coast. This important work, however, having been neglected by the Turks, the port has been to a great extent choked up. It is still visited by small vessels, and a certain amount of trade is carried on. The exports in 1869 were valued at £19,759. The town is about a mile in circuit; it is defended by several forts. The principal employment of the inhabitants is fishing. The adjoining lake abounds in fish, particularly mullets, the roes of which, dried and formed into the substance called botargo, form a considerable article of Mediterranean commerce. N. lat. 37° 17', E. long. 9° 50'. Population, 8000.

**BLACK, DR JOSEPH**, a celebrated chemist, was born, in 1728, at Bordeaux, where his father—a native of Belfast, but of Scottish descent—was engaged in the wine trade. He was educated from his twelfth to his eighteenth year at a grammar school in Belfast, whence he removed, in 1746, to the university of Glasgow. There he chose medicine as his profession, and devoted himself earnestly to physical science, being encouraged and guided by Dr Cullen, who then lectured on chemistry in Glasgow, and whose liberal and original views were in unison with Black's own aspirations. From assisting in Cullen's chemical experiments he acquired the delicate manipulative skill essential to success in original scientific research.

In 1751 he went to complete his medical studies at Edinburgh, and after taking his medical degree there in 1754 revealed himself as a great scientific discoverer. At that time the causticity of the alkalis was attributed to their absorbing an imaginary fire-essence known as phlogiston, an hypothesis which Black overthrew by showing that their causticity depended on their combining with a ponderable gas, carbonic acid, which he named *fixed air*, meaning that it was found not only as a separate fluid, but as *fixed* in solid bodies. This discovery, made by Black in his twenty-fourth year, was first sketched in a treatise, *De Acido e Cibus orto, et de Magnesia*, and afterwards embodied in his work, *Experiments on Magnesia, Quicklime, and other Alkaline Substances*, which Lord Brougham has declared to be "incontestably the most beautiful example of strict inductive investigation since the *Optics* of Sir Isaac Newton."

These works revolutionized chemistry. Previous investigators imagined that atmospheric air was the sole permanently aeriform element, a belief to which even Hales, who had shown that solids contain elastic fluids, had adhered. But when Black proved that a gas not identical with atmospheric air was found in alkalis, it was made plain



that various dissimilar gases might exist, and pneumatic chemistry was founded.

Although the full value of this discovery was not immediately visible, it added so greatly to Black's reputation that in 1756 he was chosen to succeed Dr Cullen as lecturer on chemistry in Glasgow University. He was also appointed to the chair of anatomy, but, not finding its duties congenial, exchanged it for the professorship of medicine. For some time he was so assiduous in preparing his lectures as to neglect fresh investigations, and even left the examination of carbonic acid, or *fixed air*, to be afterwards completed by Cavendish. He was highly esteemed as a professor by his students and colleagues, and became, through his attention and urbanity, a very popular physician in Glasgow. From 1759 to 1763 he prosecuted inquiries resulting in his theory of *latent heat*, which may be thus summarized—A solid liquefies or a fluid vaporizes through heat uniting with the solid or fluid body, and a fluid solidifies or a gas liquefies through the loss of heat; but in no case is this increase or diminution of heat detected by the senses or the thermometer. Black therefore named that heat *latent* which alters the condition, not the temperature, of a body. He likewise proved that bodies of equal masses require different increments of heat to raise them to the same sensible temperature—a doctrine now known as the law of *specific heat*.

His theory of latent heat he corroborated by numerous experiments, but he never published a detailed account of it, an omission which enabled others to lay claim to his great discovery. Thus M. Deluc, in 1788, declared himself its author. In 1766 Black was elected to succeed Cullen in the chair of chemistry at Edinburgh University. In this office he bestowed great care on his lectures, striving to give a lucid exposition of ascertained facts rather than to effect new discoveries; and such an interest did he communicate to his subject, that chemistry was for a time, it is said, regarded as a fashionable accomplishment in the Scottish capital.

He was intimate with the great men who adorned Edinburgh society during the second half of the eighteenth century, counting among his friends Watt, Hume, Robertson, Hutton, Adam Smith, and, at a later period, Robison, Playfair, and Dugald Stewart. His constitution had always been feeble, and he was ultimately reduced to the condition of a valetudinarian, which may account for the indifference he manifested during his latter years to original research. He retired from his professorship in 1796, and on the 26th November 1799 passed away so quietly that a cup of water, which he had held in his hand, remained unspilled after he had breathed his last. At the instance of Lavoisier he had been elected a member of the Paris Academy of Sciences.

Black was singularly modest, gentle, and sincere; his philosophic tranquillity was seldom ruffled; and his sagacious diffidence was equally conspicuous in his scientific inquiries and in his social relations. He has been called the founder of modern chemistry. When he began his career that branch of knowledge had only recently been raised to the rank of a true science through the efforts of Hermann Boerhaave, and was in many quarters even regarded with suspicion as being akin to alchemy on the one hand, and to humble trades on the other. But after Black's discoveries its scope and capabilities were immensely extended, and no one could then question its claim to rank with the most important sciences. The only works of his which appeared in print during his lifetime were *Experiments on Magnesia, &c.*, *Observations on the more ready Freezing of Water that has been boiled*, and *Analysis of the Waters of some Boiling Springs in Iceland*.

His lectures on chemistry were issued after his death. (*Cf.* Prof. Robison's *Life of Black*.)

**BLACK FOREST** (German, SCHWARZWALD), an extensive upland district on the right bank of the upper Rhine, stretching from that river to the Neckar and upper Danube. See BADEN and WÜRTTEMBERG.

**BLACK SEA**, or **EUXINE**, the *Pontus Euxinus* of the ancients, is a large inland sea, bounded on the W. by the Turkish provinces of Rumilia, Bulgaria, and Moldavia; on the N. by South Russia, including Bessarabia, Kherson, and Taurida; on the E. by the Russian provinces of Circassia and Transcaucasia; and on the S. by the Turkish provinces of Asia Minor. It is entered from the Mediterranean through the channel of the Dardanelles or *Hellaspontus*, the Sea of Marmora or *Propontis*, and the channel of Constantinople or *Thracian Bosphorus*; and it is connected with the Sea of Azoff, or *Palus Mæotis*, by the strait between the Crimea and the isle of Taman, anciently the *Cimmerian Bosphorus*, and known by the various modern names of the Strait of Kertch, of Yenikale, and of Taman.

The first navigators of Greece who ventured into this sea having been repulsed or massacred by some of the fierce tribes inhabiting its coasts, their countrymen gave it the name of *Pontus Aænes*, or "sea unfriendly to strangers." But when the repeated visits of the Greeks had rendered these tribes more familiar with strangers, and commercial intercourse had softened down the original ferocity of their character, Grecian colonies were established at different points on the shores of this sea, and the epithet *Aænes* was changed into *Euxinus*, which has the opposite import, and means "friendly to strangers." The modern name seems to have been given to it by the Turks, who, being accustomed to the navigation of the *Ægean*, the islands of which furnish numerous harbours of refuge, were appalled by the dangers of a far wider expanse of water without any shelter, subject to sudden and violent storms, and often covered with dense fogs.

The basin of the Black Sea is of an irregular ovate form, its long diameter lying nearly E. and W. Its greatest length, from the head of the Bay of Burghas in Rumilia on the west to the boundary between Transcaucasia and Asiatic Turkey near Batum on the east, is about 720 miles. Its greatest breadth is in its western portion, between the estuary of the Dnieper on the north and the mouth of the Sakaria on the south, where it is 380 miles; its middle portion is narrowed, by the projection of the Crimean peninsula on the north and of the coast line of Anatolia between Cape Kereppe and Sinope on the south, to 160 miles; but further east it widens out again between the Strait of Kertch on the north and the mouth of the Kizil Irmak (the ancient *Halys*) on the south, to 260 miles. Its total area, including the Sea of Azoff, is about 172,500 square miles. The western coast line of the Black Sea, for some distance northwards from the Bosphorus, is high and rocky, having ranges of hills at its back; and the water rapidly deepens to from 30 to 40 fathoms. Between their northern extremity and the range of the Balkans (the ancient *Hæmus*), which extends east and west, terminating in Cape Eminéh, there is a large bay, named after the town of Burghas at the head of it, which affords a safe anchorage for large ships, the only one on this coast. Between Cape Eminéh and Varna the coast line is again low and the shore shallow; and the same condition extends, with but little interruption, along the low-lying region called the Dobrudscha, which extends to the mouth of the Danube. This great river discharges itself by seven mouths, among swampy islands and shifting banks; and the quantity of *debris* brought down by it is so large as not only to form a very extensive bar, but also to require the con-

tinal use of artificial means for its removal from the bed of the navigable channels. The same low coast-line continues along the southern boundary of the Russian steppes, to the shallow inlet which forms the estuary of the Dniester, and of which the mouth is nearly closed by a bar; beyond which, towards Odessa, the coast-line is more lofty, and the waters deepen more rapidly, so that it has been possible to construct a harbour in which ships of considerable tonnage can lie securely. Between Odessa and the mouth of the Dniester the shore again becomes low, and the water shallow; and the outlet of that river, which also receives the River Bog or Bug, is a long shallow bay bordered by shifting sand-banks, which is called the Gulf of Leman or the Bay of Kherson. Only ships of light draught of water can navigate these rivers, of which the Bug is the deeper; and vessels of war, which are built and repaired at the arsenals of Kherson and Nicolaieff, are artificially floated up and down. The Crimean peninsula is separated from the mainland on the western side by the Gulf of Perekop, the northern boundary of which is formed by a narrow belt of sand that runs nearly straight for a distance of 80 miles, and was celebrated by ancient geographers as the *ὄριμος Ἀρχιπέλαγος*. The inner portion of this gulf is so shallow that only vessels of very light draught can make their way to Perekop, which is situated on the narrow isthmus that divides it from the Sea of Azoff. Along the western coast of the Crimea, however, the coast-line gradually rises, and the shore deepens more rapidly; and at Eupatoria there is a good harbour for ships of moderate size. South of Eupatoria, the coast is formed by cliffs, sometimes of considerable height; and the water is deep almost to their base. The harbour of Sebastopol somewhat resembles that of Valetta in being a deep inlet, subdividing into several branches, in any one of which the largest vessels may find good anchorage, and lie within a cable's length of the shore. Between Sebastopol and Cape Chersonese are six other bays running inland parallel to each other; and on rounding this we arrive at the harbour of Balacava, which is a remarkable inlet, having a very narrow entrance, and almost entirely surrounded by lofty heights. Eastward from Balacava there commences an almost continuous chain of lofty cliffs, with mountains behind them, whose height ranges from 4000 to 5800 feet; the commencement of this chain is formed by Cape Aia or Tarchanskoï, probably the *Parthenon* of Strabo, the most remarkable headland in the Crimea. Along the whole south-east coast of the Crimean peninsula the water is deep; but there is no good harbour between Balacava and the Bay of Kaffa, which furnishes an excellent and sheltered anchorage for large vessels, and was formerly much frequented when Kaffa or *Theodosia* (an ancient Greek colony) was a port of considerable importance. The peninsula of Kertch and the island of Taman, which separate the Sea of Azoff from the Black Sea, are for the most part low and sandy, the most elevated land in each being near the border of the Strait of Yenikale. On the western side of this strait the town of Kertch is situated, upon what was formerly known as the Hill of Mithridates.

The Sea of Azoff may be considered as the wide shallow estuary of the River Don, which discharges its waters into the north-eastern prolongation of the sea, sometimes distinguished as the Gulf of Taganrog; its area is estimated at about 14,000 square miles; and its depth, which is nowhere more than  $7\frac{1}{2}$  fathoms, diminishes near the shores to 4½ fathoms, and is less than 2 fathoms opposite the town of Taganrog. These depths show a tendency to yet further diminution through the deposit of river detritus,—vessels which could formerly pass up the gulf as far as Taganrog being no longer able to do so, whilst during certain winds the bottom becomes dry enough to be crossed between Taganrog and Azoff. The western portion of this basin is separated from the rest by a long narrow strip of low sandy land, enclosing what was named by the Greeks the Patrid Sea,—into which, when the wind is easterly, the water

of the Sea of Azoff passes through a narrow opening at the northern extremity of the bar, but which at other times consists of a series of swamps and quagmires, equally impassable to men and animals, and giving forth noxious exhalations that render the adjacent country nearly uninhabitable. The water of the Sea of Azoff is always less salt than that of the Black Sea; and when the Don is at its fullest, the large quantity of fresh water which is mingled with the water of the sea renders the latter nearly drinkable, and tends to empty the basin of its salt. When, on the other hand, the river brings down but little water, and the wind is from the south, there is a considerable reflux of the more saline water outside; and thus the average salinity of the water of the Sea of Azoff is maintained,—just as is seen to be the case on a larger scale with the Baltic. See BALTIC, p. 297.

The whole of the portion of South Russia that lies between the Dniester and the Don is an almost unbroken steppe, but very little elevated above the sea-level; and there are abundant indications of its having been at no remote period covered by salt water. For not only are there numerous salt lakes and marshes at a long distance inland from the present coast-line, but extensive beds of sea-shells, which have become mineralized into strata of solid limestone, sometimes 30 or 40 feet in thickness. The like features prevail over the plain which lies between the Don and the Kuban, and which forms the eastern boundary of the Sea of Azoff; this plain, inhabited by nomads Kalmucks and Cossacks, extends eastward to the desert of Astrakhan; and as salt marshes and beds of sea-shells are found there also, it is evident not only that both the Black Sea and the Caspian extended farther north than they do at present, but that they were then in continuity with each other over the plain of South Russia, though separated towards the south by the Caucasian Highlands. It is interesting to note that Pliny expressly stated that the Tauric Chersonese was not only surrounded by the sea, but that the sea covered all that northern portion of it which is now an alluvial level.

The island or peninsula of Taman, which forms the eastern border of the Strait of Yenikale, is for the most part an expanse of salt-marshes and lagoons, into which the River Kuban discharges itself,—one portion of its water passing into the Sea of Azoff and the rest into the Black Sea. At Anapa, a little to the east, the Caucasian range comes down to the sea; and thence around the shore of Circassia, the coast-line is high with a mountainous back-ground, and the water rapidly deepens. As the great mountain range trends inland, however, the coast becomes lower; and the region now termed Mingrelia, the ancient *Colchis*, is a fertile plain, through which run the River Rion (the ancient *Phasis*) having the important port of Poti at its mouth, and the Khopi, at the mouth of which is Redout Kale. Through these channels the merchants of Tiflis export the produce of the interior, and import European goods. Passing the boundary between Russia and Turkey, the coast-line begins to trend westwards, to the outlet of the large river Chouruk (the ancient *Batyse*), where the fortified town of Batoum is situated at the base of the northern mountain range of Asia Minor. This range extends, with occasional interruptions, along the whole southern coast of the Black Sea, sending down spurs that form headlands and promontories, sometimes of considerable height. Owing to the steepness of the shores, there are few good anchorages here, except in the Bay of Samsoun, which receives the River Yeabil, and the Bay of Sinope, which receives the Kizil-Irmak,—at the mouths of which rivers there are plains formed by their alluvial deposit. From Cape Injeh westward to the Bosphorus, the coast-line of Anatolia is continuously elevated, with high mountains in the back-ground, occasionally projecting seawards as lofty promontories, of which Cape Kerempe is the most noteworthy; numerous rivulets come down from the mountains, and discharge themselves into

little coves; but excepting the Sakaria (the ancient *Sagaris*), there is no considerable river, and the water deepens very rapidly to 20 fathoms or more.

Although it is known that the depth of the central part of the basin of the Euxine reaches 1070 fathoms, the extent of this deep depression is not known. The increase of depth off the low-lying western and north-western shores is very gradual and regular, the lines of 20, 30, and 60 fathoms maintaining a general parallelism to the coast,—so that within this range the distance of a ship from land can be approximately ascertained by sounding. But outside the 60 fathom line the bottom deepens more rapidly and less regularly, depths of from 600 to 700 fathoms being met with in some parts within a few miles of it. The depth of the eastern portion of the basin has not been ascertained, but it is probably considerable.

The basin of the Euxine communicates with that of the Sea of Marmora by the Bosphorus, a strait about 20 miles long, from  $\frac{1}{2}$  to  $2\frac{1}{2}$  miles wide, and a depth of from 30 to 40 fathoms, resembling a broad river with high banks, which maintain a general parallelism, although the strait has seven distinct reaches. The region on either side presents distinct evidence of recent volcanic action.

The Sea of Marmora lies in the course of the channel that connects the Black Sea with the *Ægean*. Its bottom is depressed to a depth far greater than that of the channel of which it is an expansion. Its length from strait to strait is 110 geographical miles, and its greatest breadth is 43 miles. Round the shores, the depth generally ranges from 10 to 30 fathoms; but it rapidly increases in most parts; and depths of 100, 133, 266, and even 355 fathoms have been met with, chiefly near the line connecting the two straits.

The channel which connects the Sea of Marmora with the *Ægean* is properly termed the Hellespont,—the name Dardanelles, by which it is commonly known, being really that of the fortifications erected on the two sides of the strait by which its passage is guarded. The Sea of Marmora narrows to a breadth of ten miles towards the north-eastern entrance of the channel; at Gallipoli, the distance between the two shores suddenly contracts to about two miles; and between this and the *Ægean* end of the strait, that distance is further diminished at certain points to even less than a mile. The depth of the channel is considerable, being for the most part between 30 and 50 fathoms.

*Climate*.—The climate of the Black Sea is very peculiar,—the range of temperature between the summer and winter extremes being remarkably great. The summer isotherm of 70° runs a little way inland, nearly parallel to its north-western coast-line, whilst the summer isotherm of 80° passes along its southern coast-line, which is as warm as the southern coast-line of the Mediterranean, nearly 10° nearer the equator. Thus the whole area of the Black Sea lies, like that of the Mediterranean, between these two summer isotherms; and the evaporation from its surface during the warmer part of the year will consequently be enormous. During the winter months, on the other hand, the Black Sea is exposed to the chilling winds which come down to it from the Arctic regions, sweeping over the snow-covered plains of Russia, without any interruption from high mountain ranges; and nearly the whole of its area lies between the winter isotherms of 30° and 40°, the former passing round its northern coast, while the latter passes from the Bosphorus to Poti in Mingrelia. Thus it happens that, notwithstanding their high summer temperature, the northern shores of the Black Sea are more or less blockaded with ice during the winter,—this being most the case where the water is shallowest, and has its salinity lowered by the entrance of rivers. Thus the Sea of Azoff

and the Strait of Yenakals are always frozen over, as are also the northern ports between the Crimea and Odessa; while, on the other hand, the harbours of Kaffa and Sebastopol are never closed, and that of Odessa but seldom. It is recorded, however, that in 401 A.D. the surface of the Euxine was almost entirely frozen over, and that when the ice broke up enormous masses were seen floating in the Sea of Marmora for thirty days. In 762 A.D., again, the sea is said to have been frozen from the terminal cliffs of the Caucasus to the mouths of the Dniester, Dnieper, and Danube; and contemporary writers assert that the quantity of snow which fell on the ice rose to the height of from 30 to 40 feet, completely hiding the contour of the shores, and that on the breaking up of the ice in the month of February, the masses of it carried by the current into the Sea of Marmora reunited in one immense sheet across the Hellespont between Sestos and Abydos. No similar occurrence has been subsequently recorded.

The winds of the Black Sea are variable, except during summer, when they generally blow from the north-east, while at other seasons southerly or south-westerly winds often prevail. The area is very subject to fogs, which appear to proceed from the precipitation by a cold northerly current of the moisture which has been raised by evaporation from its surface, or has been brought thither by N. or S.W. winds. This sea is remarkable for the rapidity with which violent storms not infrequently arise, often to subside again with like rapidity.

*Drainage Area*.—The drainage area of the Black Sea is one of the largest in the world, being estimated at 939,000 square miles, of which 825,000 lie in Europe and 114,000 in Asia. The largest of its rivers is the Danube, which has a total length of 1560 miles, and drains the immense area of 306,000 square miles in the southern portion of Central Europe; its western tributaries lie so near the southern tributaries of the Rhine and the Elbe, that a canal-communication has been established between them, by which small vessels can pass between the North Sea and the Black Sea. The Dnieper has a total length of 1080 miles, and drains an area of 195,500 square miles, chiefly in Western Russia and Russian Poland; its northern tributaries approach the southern tributaries of the Niemen; and a canal-communication has thus been established between the Black Sea and the Baltic. The Don, with a length of 1000 miles, drains an area of 176,500 square miles in South-Eastern Russia, which is continuous with the basin of the Volga, being separated from it by the Serpa Hills. Between the Dnieper and Danube, the two smaller rivers, the Bug and the Dniester, traverse respectively 440 and 660 miles in their course, and drain an area of more than 50,000 square miles (ten times greater than that of the Thames). Passing eastwards, we come to the Kuben, which drains the northern slopes of the Caucasus and the plains inhabited by the Black Sea Cossacks, and debouches near the entrance to the Sea of Azoff. But there is no other important river on the eastern coast, most of the water flowing from the mountainous region that separates the Black Sea from the Caspian passing into the latter. The northern slopes of the Armenian mountains furnish tributaries of the River Chourak, a stream of moderate size, which enters the Black Sea to the east of Trebizond. On the southern coast the principal river is the Kizil Irmak (the *Euxis* of the ancients), which drains the large central area of the northern portion of Asia Minor, while towards the western side the River Sakaria drains a large area in the province of Anatolia. Along the whole western coast of the Black Sea, from the Bosphorus to the Danube, no large stream empties itself into the basin,—most of the drainage of Rumilia being carried off by the River Maritza into the *Ægean*, whilst that of Bulgaria contributes to swell the Danube.

The greater part of the drainage area of the Black Sea, like that of the Baltic, is covered with snow during the winter months, and comparatively little water is then brought down by the rivers. With the return of spring, however, the melting of the snow increases the volume of fresh water poured into the sea, its rivers being at their highest in early summer. By far the larger part of this water is discharged at its north-western border; and the elevation of level thus produced establishes a current that sets along its western shore towards the outlet of the Bosphorus. But as the narrowness of this channel does

not allow it to give immediate passage to the overflow, a portion of the current continues to pass onwards along the southern shore, and, when more than usually strong, even completes the entire circuit of the sea. There are no perceptible tides in this basin.

As might be expected from the foregoing, the salinity of Black Sea water varies (like that of the Baltic) at different periods of the year; but in consequence of the much greater total mass of water contained in the deeper part of this basin, the variation of its salinity is by no means so great as that of Baltic waters,—the usual range of its sp. gr. being from about 1.012 to 1.014, which corresponds to a little less or a little more than half the salinity of ordinary sea-water.

The most contradictory notions have prevailed as to the influence of the Euxine waters on those of the Mediterranean,—some writers having represented the rivers of the former as important contributors to the maintenance of the level of the Mediterranean, which the enormous evaporation from that area is always tending to reduce; whilst others assert that the Bosphorus and Dardanelles' currents are entirely due to the agency of wind. A valuable *datum* is afforded by the condition of the Caspian, in the closed basin of which, contracted by a reduction of its level to 80 feet below that of the Black Sea, an equality is now established between the amount of water lost by evaporation and that which is restored by its rivers and by the rainfall on its own surface. The areas of the Caspian and of the Euxine are not very different; and though the axis of the former basin lies north and south, while that of the latter lies east and west,—so that the northern portion of the Caspian is colder, and the southern portion warmer, than the northern and southern portions of the Black Sea,—the annual average temperatures, and consequently the total evaporation, of the two areas cannot differ much. Now, the drainage area of the Volga is equal to that of the Danube, the Dnieper, and the Dniester taken together; the Ural, with the two Transcaucasian rivers, Kur and Araxes, may be considered as equaling the Don; and thus the Bug and the rivers of the Caucasus and Asia Minor may be regarded as furnishing the excess of water discharged into the Black Sea above that which is received by the Caspian. Hence, as the whole of the river and rain water annually discharged into the basin of the Caspian is only sufficient to replace that which is lost by evaporation during the same period, it follows that we may in like manner regard the principal rivers of the Black Sea as only fulfilling the same function; consequently, if the Bosphorus were closed, the water which they pour into the Euxine basin would not produce any elevation of its level, being entirely dissipated by evaporation. Thus the water which the Black Sea has to spare for the Mediterranean only represents the *excess* of its river supply above the total river supply of the Caspian; and that this excess is small in amount appears from the fact that the salinity of the water of the *Ægean* is not sensibly reduced by it below that of the Mediterranean. But that there is some excess is evident from the consideration that if the evaporation of the Black Sea were merely neutralized by the return of fresh water, its water would have the salinity of that of the great basin with which it is in free communication, instead of containing only about half its proportion. It is further evident, on the other hand, that a continual efflux of the half-salt water of the Black Sea, to be replaced only by the fresh water discharged into its basin by rain and rivers, would in time completely drain that basin of its salt; and as its proportion, though liable to seasonal variation, undergoes no sensible diminution from year to year, it is obvious that the salt which passes out must be replaced by re-entry of *Ægean* water. The mode in which this re-

placement is effected has been recently elucidated by a careful examination of the currents of the Black Sea straits, of which an account will be presently given.

It is during the winter months, when a large proportion of the drainage area of the Black Sea rivers is covered with snow, that the supply of water is at its minimum; but it is then that the evaporation from its surface is also at its minimum; so that there is no reason to suppose that the level of the Black Sea ever falls below that of the *Ægean*. There can be no reasonable doubt that during the spring and early summer, when the melting of the snows causes the rivers to swell to their highest, the quantity of fresh water thus brought into the basin, being greater than that which is lost by evaporation (as is shown by the general reduction which then takes place in the salinity of its contents), would cause a considerable rise of level, if this were not kept down by the outflow through the straits.

*Dardanelles and Bosphorus Currents.*—It has been known from very early times that a current, usually of considerable strength, sets outwards through the Black Sea straits during a large part of the year,—its rate being subject, however, to considerable variation in accordance with the breadth of the channel, and also with the force and direction of the wind. Thus, when the N.E. wind is of average strength, the rate of the current at Gallipoli is about 1 knot per hour; whilst in the "Narrows" at Chanak Kaleski it is about 3 knots, increasing with a strong wind to about 4½ knots. In calm weather the out-current of the Dardanelles is usually slack; and if, as sometimes happens even during the general prevalence of N.E. winds, the wind should suddenly blow strongly from the S.W., the surface outflow may be entirely checked. It requires a continuance of strong S.W. wind, however, to reverse its direction; and its rate, when thus reversed, never equals that of the out-current. The Bosphorus current has not been as carefully studied as that of the Dardanelles; but its rate is greater, in accordance with the limitation of its channel, which is scarcely wider at any point than the "Narrows" of the Dardanelles. It continues to run, though at a reduced rate, when there is no wind, and is not known to be ever reversed except in winter after a S.W. gale of long duration. Even then it appears that the reversal is confined to the superficial stratum,—the direction of the sub-surface water-weeds proving that there is still an outflow from the Black Sea into the *Ægean*. Hence it cannot be reasonably maintained that it is by this occasional and superficial reversal that the immense mass of salt continually being carried outwards by the Bosphorus and Dardanelles currents is restored to the Black Sea basin.

The existence of an inward under-current (although controverted by an authority of weight) has been clearly demonstrated by the recent experimental researches of Captain Wharton, R.N., of H.M. surveying ship "Shearwater." By the use of a "current-drag," so constructed and suspended as always to present a large vertical surface, it was found that when the outward surface-current was at its strongest there was an inward under-current sufficiently strong and rapid to carry inwards the suspending buoy.

The difference in specific gravity of water obtained from different depths was found, in Captain Wharton's investigations (as in those previously made by Dr Carpenter, in conjunction with Captains Calver and Nares, in the Strait of Gibraltar), to afford, under ordinary circumstances, a very sure indication of the direction of the movement of each stratum,—the heavy water of the *Ægean*, as a rule, flowing inwards, and the lighter water of the Black Sea flowing outwards. And it was indicated alike by both modes of inquiry that the two strata move in opposite directions, one over the other, with very little intermixture

or retardation,—the transition between them being usually very abrupt. The anomalies occasionally met with seemed due to the prevalence of opposite winds at the two ends of the straits.

Putting aside for the time the influence of wind, the double current of the Black Sea straits may be accounted for as follows:—The excess of fresh water discharged into the basin of the Black Sea is always tending to raise its level; and this produces an outward surface-current, which as regularly tends to keep it down. On the other hand, the reduced salinity of the Euxine column gives to the Ægean column an excess of lateral pressure, which causes its lower stratum to flow back into the Black Sea basin; and as the equality in the amount of salt thus carried back by the under-current to that which escapes by the surface-current is indicated by the maintenance of the standard salinity of Black Sea water, it follows that, as the water which escapes contains about half as much salt in equal measures as the water that enters, the volume of the latter must be about half that of the former.

Now, when the rate of the surface-current is augmented by a N.E. wind, there will be not only a more rapid lowering of the Black Sea level, but a tendency to elevation at the Ægean end of the strait; and as this will augment the difference between the downward, and therefore the lateral, pressures of the two columns, the force and volume of the inward under-current will be augmented. When, on the other hand, the S.W. direction of the wind reverses the surface-current, it tends, by piling up the water at the N.E. end of the strait, to augment the weight of the Black Sea column,—the excess of which (notwithstanding its lower salinity) over that of the Ægean column, will then produce a reversal of the under-current also. When the S.W. wind is moderate enough to check the surface outflow without reversing it, the inward under-current will likewise be brought to a stand; for a slight rise in the level of the Black Sea column will cause its greater height to compensate for the greater salinity of the Ægean column, so that their lateral pressures will be equalized.—We have here a “pregnant instance” of the potency of slight differences in level and in salinity to produce even rapid movements of considerable bodies of water; and a strong confirmation is thus afforded by direct observation to the doctrine that differences in density produced by temperature are adequate to give rise to still larger, though slower, movements of the same kind in the great ocean basins.

*Zoology.*—The basin of the Black Sea is frequented by seals, dolphins, and porpoises; and it is said that in the neighbourhood of the mouths of the Danube the porpoise is perfectly white, so that the Greek mariners, when they catch sight of it, know that they are in the current of that river, although in 30 fathoms water, and many leagues from land. The fish of the Black Sea appear to be for the most part the same as those of the Caspian and the Sea of Aral. Its northern rivers bring into it the sturgeon, sterlet, and other fresh-water fish, which can live in and near their estuaries. On the other hand, its waters are elsewhere salt enough for the mackerel, whiting, mullet, turbot, and sole. The *pelamys* spoken of by Strabo as issuing from the *Maotis* (Sea of Azoff) in shoals, and as following the coast of Asia, is still abundant; though commonly spoken of as the herring, it seems to be a large sprat. The principal fish that enters this basin from the Mediterranean is the tunny, which comes into the Black Sea in large numbers at the spawning season. The other inhabitants of the Black Sea have not been especially studied; but it may be noted that a species of *T.redo* is very common and destructive both to ships and to wooden harbour-works, and that it is not confined to the saltier waters of the basin, but frequents the estuaries where the water is almost fresh. (W. B. C.)

**BLACKBIRD** (*Turdus merula*), belongs to the *Turdidae* or Thrushes, a family of Dendrostratal Birds. The plumage of the male is of a uniform black colour, that of the female various shades of brown, while the bill of the male, especially during the breeding season, is of a bright gamboge yellow. The blackbird is of a gay and restless disposition, courting concealment, and rarely seen in flocks, or otherwise than singly or in pairs, and taking flight when startled with a sharp shrill cry. It builds its nest in March, or early in April, in thick bushes or in ivy-clad trees, and usually rears two broods each season. The nest is a neat structure of coarse grass and moss, mixed with earth, and plastered internally with mud, and here the female lays from four to six eggs of a blue colour speckled with black. The blackbird feeds chiefly on fruits, worms, the larvæ of insects, and snails, extracting the latter from their shells by dexterously chipping them on stones; and though it is generally regarded as an enemy of the garden, it is probable that the amount of damage done by it to the fruit is amply compensated for by its undoubted services as a vermin-killer. The notes of the blackbird are rich and full, but monotonous as compared with those of the song-thrush. Like many other singing birds it is, in the wild state, a mocking-bird, having been heard to imitate the song of the nightingale, the crowing of a cock, and even the cackling of a hen. In confinement it can be taught to whistle a variety of tunes, and even to imitate the human voice. It is found throughout Europe, Palestine, and the northern parts of Africa, and Dr. Swin states that he observed it as far west as the Azores. Individuals reared in Britain, it is said, do not migrate; but annually great flocks arrive on the eastern shores of England from more northern countries, remaining for a few days only, and then proceeding southward.

**BLACKBURN**, a large manufacturing town and municipal borough of England, situated on a stream called, in *Domesday Book*, the Blackburn, but now only known as “The Brook,” in the north-eastern division of the county of Lancaster, 209 miles from London by railway, 15 E. of Preston, and 30 N.N.W. of Manchester. Besides its numerous churches and chapels, the public buildings of Blackburn comprise a large town-hall, finished in 1856, a market-house, an exchange, built in 1865, a county court (1863), public baths (1864), and, outside the town, an infirmary (1862). A public park of about 50 acres was opened in 1857. Since about 1865 a variety of extensive and important improvements have been effected in the general condition of the town, which is now well paved and lighted, has an elaborate system of drainage, and receives an abundant supply of water. Previous to that date the so-called streets were, over a large area, almost useless for purposes of traffic. The staple trade of Blackburn has long been the manufacture of cotton, for the development of which a great deal was done by some natives of the town, such as Peel and Hargreaves, in the last century. The subordinate branches include woollen factories, engineering works, iron foundries, and breweries. In 1871 there were employed in the cotton factories 14,220 men and 17,075 women, of twenty years of age and upwards, the engineering works gave employment to 356 men, and the iron manufacture to 794. Coal, and lime, and building stone are abundant in the neighbouring district, which is, however, very far from fertile. The Leeds and Liverpool Canal passes the town, which has also extensive railway communication. Blackburn is a place of some antiquity, and its parish church of St Mary’s (for the most part taken down in 1813), dated from before the Norman Conquest. It was for a time the chief town of a district known as Blackburnshire, and as early as the reign of Elizabeth ranked as a flourishing market town. About

the middle of the 17th century it became famous for its "cheeks," which were afterwards superseded by a similar linen-and-cotton fabric known as "Blackburn greys." A charter of incorporation was obtained in 1851, when W. H. Hornby, one of the largest cotton manufacturers of the place, was elected first mayor. The population of the town, which was only about 5000 in 1790, had increased by 1801 to 11,980. In 1861 there were 11,306 inhabited houses in the municipal borough; and by the census of 1871 the number had increased to 14,690. In the former year the population of the municipal borough was 63,126, and in 1871 it amounted to 76,339 (males 36,099, females 40,240), while the parliamentary burgh with its extended boundaries contained 82,928 inhabitants. Blackburn returns two members to parliament.

**BLACKCOCK** (*Tetrao tetrax*), a Gallinaceous Bird belonging to the family *Tetraonidae* or Grouse, the female of which is known as the Grey Hen and the young as Poults. In size and plumage the two sexes offer a striking contrast, the male weighing about 4 lb, its plumage for the most part of a rich glossy black shot with blue and purple, the lateral tail feathers curved outwards so as to form, when raised, a fan-like crescent, and the eyebrows destitute of feathers and of a bright vermilion red. The female, on the other hand, weighs only 2 lb, its plumage is of a russet brown colour irregularly barred with black, and its tail feathers are of the ordinary form or but slightly forked. The males are polygamous, and during autumn and winter associate together, feeding in flocks apart from the females; but with the approach of spring they separate, each selecting a locality for itself, from which it drives off all intruders, and where morning and evening it seeks to attract the other sex by a display of its beautiful plumage, which at this season attains its greatest perfection, and by a peculiar cry, which Selby describes as "a crowing note, and another similar to the noise made by the whetting of a scythe." Its nest, composed of a few stalks of grass, is built on the ground, usually beneath the shadow of a low bush or a tuft of tall grass, and here the female lays from six to ten eggs of a dirty-yellow colour speckled with dark brown. The blackcock then rejoins his male associates, and the female is left to perform the labours of hatching and rearing her young brood. The plumage of both sexes is at first like that of the female, but after moulting the young males gradually assume the more brilliant plumage of their sex. There are also many cases on record, and specimens may be seen in the principal museums, of old female birds assuming, to a greater or less extent, the plumage of the male. The blackcock is very generally distributed over the highland districts of Northern and Central Europe, and in some parts of Asia. It is found on the principal heaths in the south of England, but is specially abundant in the Highlands of Scotland, where great numbers are killed annually during the statutory shooting season, which commences on August 20 and extends to December 10. The bird does not occur in Ireland, and all attempts that have hitherto been made to naturalize it there have failed, although it now thrives and breeds in the south-west of Scotland within 21 miles of the Irish coast. During summer, blackcock reside chiefly on the ground, feeding on seeds, the young shoots of heath, and insects; in autumn they regularly frequent the stubble fields; but in winter they perch on trees, especially the birch and fir, the tender shoots of which then form their principal food.

**BLACKLOCK**, THOMAS, a Scottish poet and divine, was born of humble but respectable parents at Annan, in Dumfriesshire, in 1721. When not quite six months old he lost his sight by the smallpox. Under this misfortune, his father and friends endeavoured to amuse him as he grew up by reading to him various books,—among others,

the works of Milton, Spenser, Prior, Pope, and Addison. Shortly after the death of his father, which took place in 1740, some of Blacklock's poems began to be handed about among his acquaintances and friends, and a few specimens were brought under the notice of Dr Stevenson of Edinburgh, who was struck by their merits, and formed the design of giving the author a classical education. Blacklock, in consequence, was enrolled a student of divinity in the university of Edinburgh in 1741, and continued his studies under the patronage of Dr Stevenson till 1745, when he retired to Dumfries, and resided there until the close of the civil war. When peace had been restored, he returned to the university, and during this residence in Edinburgh he made the acquaintance of several literary men, in particular of Hume, who was extremely useful to him in the publication by subscription of the 4to edition of his poems in 1756. Two editions in 8vo had previously been published at Edinburgh, in 1746 and in 1754. After applying closely for a considerable time to the study of theology, he was in 1763 ordained minister of the church of Kirkcudbright; but owing to an opposition to the appointment on the part of the parishioners, he resigned his right to the living, and accepted a moderate annuity in its stead. In 1767 the degree of doctor in divinity was conferred on him by Marischal College, Aberdeen. He died on the 7th of July 1791. His poems are pleasing but weak effusions, and there is nothing remarkable about them save that they were written by one who laboured under the misfortune of blindness.

**BLACKMORE**, SIR RICHARD, a physician, and voluminous writer of theological and poetical works, was born in Wiltshire about 1650. He was educated at Westminster and Oxford, graduated in medicine at Padua, and settled in practice as a physician in London. Having early declared in favour of the Revolution, he was in 1697 chosen one of King William's physicians in ordinary, and received the honour of knighthood. On Queen Anne's accession, Sir Richard was also appointed one of her physicians, which office he held for some time. He died on the 9th October 1729. Blackmore had a passion for writing epics. No fewer than seven long poems were published by him between 1695 and 1723. The first was *Prince Arthur*, in 10 books; then followed *King Arthur*, in 12 books; *Eliza*, in 10; *Creation*, in 7; *Redemption*, in 6; *Nature of Man*, in 3; and *Alfred*, in 12. Of these *Creation*, a philosophic poem directed against the atomic theories of Epicurus and Lucretius, and intended to refute the atheism of Vanini, Hobbes, and Spinoza, and to unfold the intellectual philosophy of Locke, has been the most favourably received. Addison and Johnson praised it highly, the latter anticipating that this poem would transmit the author to posterity "among the first favourites of the English muse." It would be hard to find grounds for this expectation, which has certainly not been realized. The poem, like everything else that Blackmore wrote, is dull and tedious, and exhibits in every part the author's want of true poetic sensibility and taste.

**BLACKPOOL**, a seaside town of England, in Lancashire, situated on the coast to the north of the estuary of the Ribble, about 20 miles W. of Preston by rail. It is largely frequented as a bathing-place. A good sandy beach, bracing air, and a fine view, are its chief attractions. In the end of last century it was a mere hamlet, but since then it has gradually increased. It has two churches, two market-halls, a court-house, and assembly rooms. The parade affords a fine promenade. A new pier was built in 1866. Population in 1871, 6100.

**BLACKSTONE**, SIR WILLIAM, an eminent English jurist, was born at London, July 10, 1723. He was a posthumous child, and his mother died before he was twelve

years old. From his birth the care of his education was undertaken by his maternal uncle Thomas Bigg, an eminent surgeon in London. When about seven years old he was sent to the Charterhouse School, and in 1735 he was admitted upon the foundation there by the nomination of Sir Robert Walpole. His progress was so rapid that at the age of fifteen he was at the head of the school, and qualified to be removed to the university, and he was accordingly entered a commoner at Pembroke College, Oxford, on the 30th of November 1738. At the time of entering he held an exhibition from his school, and in February following he was elected by his college to one of Lady Holford's exhibitions for Charterhouse scholars. He was a diligent student, devoting himself specially though not exclusively to the Greek and Roman poets. At the only age of twenty he compiled a treatise, entitled *Elements of Architecture*, intended for his own use only and not for publication, which was highly spoken of by those who were permitted to read it.

Having made choice of the profession of the law, he was entered in the Middle Temple, November 20, 1741. In a copy of verses of considerable merit, afterwards published by Dodsley in the fourth volume of his *Miscellanies*, entitled *The Lawyer's Farewell to his Muse*, he gave utterance to the regret with which he abandoned the pleasing pursuits of his youth for severer studies. Besides this, several fugitive pieces were at times communicated by him to his friends; and he left, but not with a view to publication, a small collection of juvenile pieces, consisting of both original poems and translations. Some notes which just before his death he communicated to Steevens, and which were inserted by the latter in his last edition of Shakespeare's works, show how well he understood the meaning and relished the beauties of his favourite English poet.

In November 1743 he was elected into the society of All Souls' College. In the November following he spoke the anniversary speech in commemoration of Archbishop Chichele, the founder, and the other benefactors to that house of learning, and was at the same time admitted actual fellow. From this period he divided his time between the university and the Temple, where he took chambers in order to attend the courts. In the former he pursued his academical studies, and on the 12th of June 1745 took the degree of bachelor of civil law; in the latter he applied himself closely to his profession, both in the hall and in his private studies; and on the 28th of November 1746 he was called to the bar. Though but little known or distinguished in Westminster Hall, he was actively employed, during his occasional residences at the university, in taking part in the internal management of his college. In May 1749, as a small reward for his services, and to give him further opportunities of advancing the interests of the college, Blackstone was appointed steward of its manors. In the same year, on the resignation of his uncle, Seymour Richmond, he was elected recorder of the borough of Wallingford in Berkshire. On the 26th of April 1750 he commenced doctor of civil law, and thereby became a member of the convocation, which enabled him to extend his views beyond the narrow circle of his own society, to the benefit of the university at large. In the summer of 1753 he took the resolution of wholly retiring to his fellowship and an academical life, still continuing the practice of his profession as a provincial counsel.

His lectures on the laws of England appear to have been an early and favourite idea; for in the Michaelmas term immediately after he quitted Westminster Hall, he entered on the duty of reading them at Oxford; and we are told by the author of his *Life*, that even at their commencement, the high expectations formed from the acknowledged abilities of the lecturer attracted to these lectures a very

crowded class of young men of the first families, characters, and hopes. Bentham, however, declares that he was a "formal, precise, and affected lecturer—just what you would expect from the character of his writings—cold, reserved, and wary, exhibiting a frigid pride." It was not till the year 1758 that the lectures in the form they now bear were read in the university. Mr Viner having by his will left not only the copyright of his abridgment, but other property to a considerable amount, to the University of Oxford, in order to found a professorship, fellowships, and scholarships of common law, Blackstone was on the 20th of October 1758 unanimously elected Vinerian professor; and on the 25th of the same month he read his first introductory lecture, which he published at the request of the vice-chancellor and heads of houses, and afterwards prefixed to the first volume of his celebrated *Commentaries*. It is doubtful whether the *Commentaries* were originally intended for the press; but many imperfect and incorrect copies having got into circulation, and a printed edition of them being either published or preparing for publication in Ireland, the author thought proper to print a correct edition himself, and in November 1765 published the first volume, under the title of *Commentaries on the Laws of England*. The remaining parts of the work were given to the world in the course of the four succeeding years. It ought to be remarked, that before this period the reputation which his lectures had deservedly acquired for him had induced him to resume his practice in Westminster Hall; and, contrary to the general order of the profession, he who had quitted the bar for an academic life was sent back from the college to the bar with a considerable increase of business. He was likewise elected to parliament, first for Hindon, and afterwards for Westbury in Wilts; but in neither of these departments did he equal the expectations which his writings had raised. The part he took in the Middlesex election drew upon him the attacks of some persons of ability in the senate, and likewise a severe animadversion from the caustic pen of *Jesuita*. This circumstance probably strengthened the aversion he professed to parliamentary attendance, "where," he said, "amidst the rage of contending parties, a man of moderation must expect to meet with no quarter from any side." In 1770 he declined the place of solicitor-general; but shortly afterwards, on the promotion of Sir Joseph Yates to a seat in the court of Common Pleas, he accepted a seat on the bench, and on the death of Sir Joseph succeeded him there also. Blackstone died on the 14th February 1780, in the fifty-seventh year of his age.

The design of the *Commentaries* is exhibited in his first Vinerian lecture printed in the introduction to them. The author there dwells on the importance of noblemen, gentle men, and educated persons generally being well acquainted with the laws of the country; and his treatise, accordingly, is as far as possible a popular exposition of the laws of England. Falling into the common error of identifying the various meanings of the word law, he advances from the law of nature (being either the revealed or the inferred will of God) to municipal law, which he defines to be a rule of civil conduct prescribed by the supreme power in a state commanding what is right and prohibiting what is wrong. On this definition he founds the division observed in the *Commentaries*. The objects of law are rights and wrongs. Rights are either rights of persons or rights of things. Wrongs are either public or private. These four headings form respectively the subjects of the four books of the *Commentaries*.

Blackstone was by no means what would now be called a scientific jurist. He has only the vaguest possible grasp of the elementary conceptions of law. He evidently regards the law of gravitation, the law of nature, and the law of

England, as different examples of the same principle—as rules of action or conduct imposed by a superior power on its subjects. He propounds in terms a fallacy which is perhaps not yet quite expelled from courts of law, viz., that municipal or positive laws derive their validity from their conformity to the so-called law of nature or law of God. "No human laws," he says, "are of any validity if contrary to this." His distinction between rights of persons and rights of things, implying, as it would appear, that things as well as persons have rights, is attributable to a misunderstanding of the technical terms of the Roman law. In distinguishing between private and public wrongs (civil injuries and crimes) he fails to seize the true principle of the division. Austin, who accused him of following slavishly the method of Hale's *Analysis of the Law*, declares that he "blindly adopts the mistakes of his rude and compendious model; missing invariably, with a nice and surprising infelicity, the pregnant but obscure suggestions which it proffered to his attention, and which would have guided a discerning and inventive writer to an arrangement comparatively just." By the want of precise and closely-defined terms, and his tendency to substitute loose literary phrases, he falls occasionally into irreconcilable contradictions. Even in discussing a subject of such immense importance as equity, he hardly takes pains to discriminate between the legal and popular senses of the word, and, from the small place which equity jurisprudence occupies in his arrangement, he would scarcely seem to have realized its true position in the law of England. Subject, however, to these strictures the completeness of the treatise, its serviceable if not scientific order, and the power of lucid exposition possessed by the author demand emphatic recognition. Blackstone's defects as a jurist are more conspicuous in his treatment of the underlying principles and fundamental divisions of the law than in his account of its substantive principles.

Blackstone by no means confines himself to the work of a legal commentator. It is his business, especially when he touches on the framework of society, to find a basis in history and reason for all our most characteristic institutions. There is not much either of philosophy or fairness in this part of his work. Whether through the natural conservatism of a lawyer, or through his own timidity and subserviency as a man and a politician, he is always found to be a specious defender of the existing order of things. Bentham accuses him of being the enemy of all reform, and the unscrupulous champion of every form of professional chicanery. Austin says that he truckled to the sinister interests and mischievous prejudices of power, and that he flattered the overweening conceit of the English in their own institutions. He displays much ingenuity in giving a plausible form to common prejudices and fallacies; but it is by no means clear that he was not imposed upon himself. More undeniable than the political fairness of the treatise is its merit as a work of literature. It is written in a most graceful and attractive style, and although no opportunity of embellishment has been lost, the language is always simple and clear. Whether it is owing to its literary graces, or to its success in flattering the prejudices of the public to which it was addressed, the influence of the book in England has been extraordinary. Not lawyers only, and lawyers perhaps even less than others, accepted it as an authoritative revelation of the law. It performed for educated society in England much the same service as was rendered to the people of Rome by the publication of their previously unknown laws. It is more correct to regard it as a handbook of the law for laymen than as a legal treatise; and as the first and only book of the kind in England it has been received with somewhat indiscriminating reverence. It is certain that a vast amount of

the constitutional sentiment of the country has been inspired by its pages. To this day Blackstone's criticism of the English constitution would probably express the most profound political convictions of the majority of the English people. Long after it has ceased to be of much practical value as an authority in the courts, it remains the arbiter of all public discussions on the law or the constitution. On such occasions the *Commentaries* are apt to be construed as strictly as if they were a code. It is amusing to observe how much importance is attached to the *speciosa verba* of a writer who aimed more at presenting a picture intelligible to laymen than at recording the principles of the law with technical accuracy of detail. (R. R.)

BLAINVILLE, HENRI-MARIE DUCROTAY DE, a distinguished naturalist, was born at Arques, near Dieppe, Sept. 13, 1777. About the year 1795 he entered the school of design at Rouen, but after a very short time he went to Paris, where he became a pupil of Vincent the painter. Attracted by the lectures of Cuvier and other eminent professors in the College of France, he commenced the study of anatomy, and in 1808 he took the degree of M.D. He now devoted himself to the study of natural history, particularly the department of myology, and he soon attracted the attention of Cuvier, who engaged him to draw some figures for one of his works, and to carry out some of the practical work of anatomy. He was also chosen by that illustrious professor to supply his place on occasions at the College of France and at the Athenæum, and in 1812 he obtained the vacant chair of anatomy and zoology in the Faculty of Sciences at Paris. His somewhat irascible disposition was probably one cause of the subsequent estrangement between him and Cuvier, which ended in an open and irreconcilable enmity. In 1825 Blainville was admitted a member of the Academy of Sciences; and in 1830 he was appointed to succeed Lamarck in the chair of natural history at the museum. This he resigned in 1832, being appointed on the death of Cuvier to the chair of comparative anatomy, which he continued to occupy for the space of eighteen years, and in the conduct of which he proved himself no unworthy successor to his great teacher. Blainville was found dead in a railway carriage while travelling between Rouen and Caen, May 1, 1850.

Besides a great variety of separate memoirs, he was the author of *Prodrome d'une Nouvelle Distribution Méthodique du Règne Animal*, 1816; *Otolographie ou Description Iconographique Comparée du Squalette*, &c.; *Faune Française*, 1821-1830; *Cours de Phytologie Générale et Comparée*, 1833; *Manuel de Malacologie et de Conchyliologie*, 1835-1837; *Histoire des Sciences Naturelles au Moyen Age*, 1846.

BLAIR, or PORT-BLAIR, the chief place in the convict settlement of the Andaman Islands in the Indian Ocean, is situated on the south-east shore of the South Andaman Island, in 11° 42' N. lat. and 93° E. long. In 1789 it was selected as a convict settlement, under orders of the Indian Government, by Lieutenant Blair, R.N., whose name the port bears. It possesses one of the best harbours in Asia, while its central position in the Bay of Bengal gives it immense advantage as a place of naval rendezvous for military operations in this part of the world. For further particulars see ANDAMAN ISLANDS.

BLAIR, DR HUGH, was born April, 7, 1718, at Edinburgh, where his father was a merchant. He entered Edinburgh University in 1730 and won the favourable notice of Professor Stevenson by an essay on the Beautiful, written for the logic class in his sixteenth year. On taking the degree of M.A. in 1739, he printed a thesis *De Fundamentis et Obligations Legis Naturæ*, which contains an outline of the moral principles afterwards unfolded in his sermons. He was licensed to preach in 1741, and in a few months the earl of Leven, hearing of his eloquence,



presented him to the pariah of Collesie in Fife. In 1743 he was elected to the second charge of the Canongate Church, Edinburgh, where he performed the pastoral duties with great success, until removed to Lady Yester's, one of the city churches, in 1754. He married his cousin, Katherine Bannatyne, in 1748, and by her had a son, who died in infancy, and a daughter who lived to her twenty-first year. In 1757 the University of St Andrews conferred on him the degree of D.D., and in the following year he was promoted to the High Church, Edinburgh, the most important charge in Scotland. In 1759 he commenced, under the patronage of Lord Kames, to deliver a course of lectures on composition, the success of which led to the foundation of a chair of rhetoric and belles lettres in the Edinburgh University. To this chair he was appointed in 1762, with a salary of £70 a year. Having long taken interest in the Celtic poetry of the Highlands, he published in 1763 a laudatory *Dissertation* on Macpherson's *Osian*, of which he maintained the authenticity. This critique, after being greatly overrated at the time, has now fallen into neglect. In 1777 the first volume of his *Sermons* appeared. It was succeeded by other four volumes, all of which met with the greatest success. Dr Samuel Johnson praised them warmly. "I love Blair's *Sermons*," Johnson said, "his doctrine is the best limited, the best expressed; there is the most warmth without fanaticism, the most rational transport." The *Sermons* were translated into almost every language of Europe, and in 1780, to signify the royal approbation, George III. conferred upon him a pension of £200 a year. In 1783 he retired from his professorship and published his *Lectures on Rhetoric* which he had carefully revised, and which have been frequently reprinted. He died, after a brief illness, on the 27th December 1801. In the church Blair belonged to the "moderate" or latitudinarian party, and his *Sermons* have been objected to as deficient in doctrinal definiteness. His once brilliant reputation is now becoming forgotten. His works display little originality, but are written in a flowing and elaborate style; and his *Rhetoric*, although inferior to Campbell's, and wanting in research and depth of thought, is unworthy of the neglect it has met with.

BLAIR, ROBERT, author of the well-known poem entitled *The Grave*, was the eldest son of the Rev. Robert Blair, of Edinburgh. He was probably born at Edinburgh about the year 1700, and at the university of that city he received the elements of a classical education. He afterwards spent some time on the Continent. Upon his return he took orders, and in 1731 was ordained minister of Athelstaneford, in East Lothian, where he spent the remainder of his life. He died of fever, February 4, 1746, and was succeeded in his living by John Home, the author of *Douglas*. His fourth son became lord-president of the Court of Session. Blair wrote several other pieces besides *The Grave*; but that poem alone constitutes his title to rank as a poet. It consists of a succession of descriptions and reflections, which have no other connection except what they may derive from their relation to a common subject, but these are interspersed with striking allusions, picturesque imagery, touches of a rude though effective pathos, and a vein of sentiment at once natural and just. The rhythm is often harsh, and the versification frequently devoid of correctness, harmony, and grace; but it has nevertheless a masculine vigour and freshness about it, which more than atone for the defects in the finishing; while, in certain moods of the mind, the air of deep and almost misanthropical melancholy diffused over the whole proves highly touching and impressive. Campbell, in the *Pleasures of Hope*, has borrowed, with a slight variation, a line from this poem—

"Its visits,  
Like those of angels, short and far between."

The vigorous, though occasionally rather forced, poetic conceptions of the author of *The Grave*, were finely illustrated in Cromek's edition, published in 1808, by the grandly wild designs of William Blake, engraved by the delicate burin of Schiavonetti. *The Grave* was first printed at London in 1743.

BLAKE, ROBERT, the famous English admiral of the Commonwealth, was born at Bridgwater in Somersetshire, in August 1598. His birth thus falls in the year before that of Cromwell; their lives ran parallel in the service of their country; their characters present many points of likeness; and they died within a few months of each other. Blake was the eldest son of a well-to-do merchant, and received his early education at the grammar school of Bridgwater. At the age of sixteen he was sent to Oxford, entering at first St Alban's Hall, but removing afterwards to Wadham College, then recently founded by his father's friend, Nicholas Wadham. He remained at the university till 1623, and though certainly not wanting in ability or in diligence, he missed, for some reason not clearly ascertained, such college preferment as he naturally aimed at. From Oxford, after taking his degree of M.A., he returned to his father's house, where, through the memorable and troubled years which followed, he led a quiet and retired life. His thorough honesty, his public spirit and disinterestedness, his courageous utterance of what he thought of the court and the church, of shipmoney and the High Commission Court and the licence of the times, made him a man of mark among his neighbours. And when, after eleven years of kingship without parliaments, a parliament was summoned to meet in April 1640, Blake was elected by the Presbyterian party to represent his native borough. This parliament, named "the Short," was dissolved in three weeks, and the career of Blake as a politician was suspended. Two years later the inevitable conflict began. Blake declared for the Parliament; and thinking, says Johnson, a bare declaration for right not all the duty of a good man, he raised a troop of horse in his county, and rendered such efficient service, that in 1643 he was entrusted with the command of one of the forts of Bristol. This he stoutly held during the siege of the town by Prince Rupert, and was near being hung for continuing his resistance after the governor had capitulated. In the following year Colonel Blake took Taunton by surprise, and notwithstanding its imperfect defences and inadequate supplies, held the town for the Parliament against two sieges by the Royalists, until July 1645, when it was relieved by Fairfax. Blake did not approve of the trial and execution of Charles I.; but he adhered to the Parliamentary party after the king's death, and within a month (February 1649) was appointed, with Colonels Dean and Popham, to the command of the fleet, under the title of General of the Sea. In April he was sent in pursuit of Prince Rupert, who with the Royalist fleet had entered the harbour of Kinsale in Ireland. There he blockaded the Prince for six months; and when the latter, in want of provisions, and hopeless of relief, succeeded in making his escape with the fleet and in reaching the Tagus, Blake followed him thither, and again blockaded him for some months. The king of Portugal refusing permission for Blake to attack his enemy, the latter made reprisals by falling on the Portuguese fleet, richly laden, returning from Brazil. He captured seventeen ships and burnt three, bringing his prizes home without molestation. After re-vice-revailing his fleet, he sailed again, captured a French man-of-war, and then pursued Prince Rupert once more to the harbour of Carthage. The Spanish governor would not allow him to violate the peace of a neutral port, and he therefore withdrew. In January 1651 he at last attacked the Royalist fleet in Malaga harbour, and destroyed the whole

with the exception of two ships. In consequence of the Portuguese protest against his proceedings, a formal investigation was instituted in England, which resulted in the approval of the home authorities. The thanks of Parliament were voted to Blake, and he was appointed warden of the Cinque Ports. He was continued in his office of admiral and general of the sea; and in May following he took, in conjunction with Ayacue, the Scilly Islands. For this service the thanks of Parliament were again awarded him, and he was soon after made a member of the Council of State. In 1652 war broke out with the Dutch, who had made great preparations for the conflict. In March the command of the fleet was given to Blake for nine months; and in the middle of May the Dutch fleet of forty-five ships, led by their great admiral Van Tromp, appeared in the Downs. Blake, who had only twenty ships, sailed to meet them, and the battle took place off Dover on May 19. The Dutch were defeated in an engagement of four or five hours, lost two ships, and withdrew under cover of darkness. Attempts at accommodation were made by the States, but they failed. Early in July war was formally declared, and in the same month Blake captured a large part of the Dutch fishery-fleet and the twelve men-of-war that formed their convoy. On September 28, Blake and Penn again encountered the Dutch fleet, now commanded by De Ruyter and De Witt, in the Downs, defeated it, and chased it for two days. The Dutch took refuge in Goree. A third battle was fought near the end of November. By this time the ships under Blake's command had been reduced in number to forty, and nearly the half of these were useless for want of seamen. Van Tromp, who had been reinstated in command, appeared in the Downs, with a fleet of eighty ships besides ten fire-ships. Blake, nevertheless, risked a battle, but was defeated, and withdrew into the Thames. It was in his first elation at this victory that Van Tromp carried the broom at his mast-head in his passage through the Channel, as a pledge of his determination to sweep the English off the seas. His bravo was speedily avenged. The English fleet having been refitted, put to sea again in February 1653; and on the 18th, Blake, at the head of eighty ships, encountered Van Tromp in the Channel. The Dutch forces, according to Clarendon, numbered 100 ships of war, but according to the official reports of the Dutch, only seventy. The battle was severe, and continued through three days, the Dutch however retreating, and taking refuge in the shallow waters off the French coast. In this action Blake was severely wounded. In the change of Government introduced by the dismissal of the Long Parliament by Cromwell (April 1653) Blake did not interfere. "It is not," he said, "the business of a seaman to mind state affairs, but to hinder foreigners from fooling us." The three English admirals put to sea again in May; and on June 3d and 4th another battle was fought near the North Foreland. On the first day Dean and Monk were repulsed by Van Tromp; but on the second day the scales were turned by the arrival of Blake, and the Dutch retreated to the Texel. Ill health now compelled Blake to retire from the service for a time, and he did not appear again on the seas for about eighteen months; meanwhile he sat as a member of the Little Parliament (Barebones's). In November 1654 he was selected by Cromwell to conduct a fleet to the Mediterranean to exact compensation from the Duke of Tuscany, the knights of Malta, and the piratical states of North Africa, for wrongs done to English merchants. This mission he executed with his accustomed spirit and with complete success. Tunis alone dared to resist his demands, and Tunis paid the penalty of the destruction of its two fortresses by English guns. In the winter of 1655-56, war being declared against Spain, Blake was sent to cruise off Cadiz and the

neighbouring coasts, to intercept the Spanish shipping. One of his captains captured a part of the Plate fleet in September 1656. In April 1657 Blake, then in very ill health, suffering from dropsy and scurvy, and anxious to have assistance in his arduous duties, heard that the Plate fleet lay at anchor in the bay of Santa Cruz, in the island of Teneriffa. The position was a very strong one, defended by a castle and several forts with guns. Under the shelter of these lay a fleet of sixteen ships drawn up in crescent order. Captain Stayner was ordered to enter the bay and fall on the fleet. This he did. Blake followed him. Broadides were poured into the castle and the forts at the same time; and soon nothing was left but ruined walls and charred fragments of burnt ships. The wind was blowing hard into the bay; but suddenly, and fortunately for the heroic Blake, it shifted, and carried him safely out to sea. "The whole action," says Clarendon, "was so incredible that all men who knew the place wondered that any sober man, with what courage soever endowed, would ever have undertaken it; and they could hardly persuade themselves to believe what they had done; while the Spaniards comforted themselves with the belief that they were devils and not men who had destroyed them in such a manner." The English lost one ship and 200 men killed and wounded. The thanks of Parliament were voted to officers and men; and a very costly jewel (diamond ring) was presented to Blake, "as a testimony," says Cromwell in his letter of June 10th, "of our own and the Parliament's good acceptance of your carriage in this action." "This was the last action of the brave Blake." After again cruising for a time off Cadiz, his health failing more and more, he was compelled to make homewards before the summer was over. He died at sea, but within sight of Plymouth, August 17, 1657. His body was brought to London and embalmed, and after lying in state at Greenwich House was interred with great pomp and solemnity in Westminster Abbey. In 1661 Charles II. disgraced himself by ordering the exhumation of Blake's body, with those of the mother and daughter of Cromwell and several others. They were cast out of the abbey, and were reburied in the churchyard of St Margaret's. "But that regard," says Johnson, "which was denied his body has been paid to his better remains, his name and his memory. Nor has any writer dared to deny him the praise of intrepidity, honesty, contempt of wealth, and love of his country." Clarendon bears the following testimony to his excellence as a commander:—"He was the first man that declined the old track, and made it apparent that the science might be attained in less time than was imagined. He was the first man that brought ships to contain castles on the shore, which had ever been thought very formidable, but were discovered by him to make a noise only, and to fright those who could be rarely hurt by them." A life of Blake is included in the work entitled *Lives, English and Foreign*. Dr Johnson wrote a short life of him, and in 1852 appeared Mr Hepworth Dixon's fuller narrative, *Robert Blake, Admiral and General at Sea*. (w. l. r. c.)

BLAKE, WILLIAM, poet and painter, was born in London, on 28th November 1757. His father, James Blake, kept a hosier's shop in Broad Street, Golden Square; and from the scanty education which the young artist received, it may be judged that the circumstances of the family were not very prosperous. For the facts of William Blake's early life the world is indebted to a little book, called *A Father's Memoirs of a Child*, written by Dr Malkin, and published in 1806. Here we learn that young Blake quickly developed a taste for design, which his father appears to have had sufficient intelligence to recognize and assist by every means in his power. At the age of ten the boy was sent to a drawing school kept by Mr Parr

in the Strand, and at the same time he was already cultivating his own taste by constant attendance at the different art sale rooms, where he was known as the "little connoisseur." Here he began to collect prints after Michel Angelo, and Raphael, Durer, and Hemskerck, while at the school in the Strand he had the opportunity of drawing from the antique. After four years of this preliminary instruction Blake entered upon another branch of art study. In 1777 he was apprenticed to James Basire, an engraver of repute, and with him he remained seven years. His apprenticeship had an important bearing on Blake's artistic education, and marks the department of art in which he was made technically proficient. In 1778, at the end of his apprenticeship, he proceeded to the school of the Royal Academy, where he continued his early study from the antique, and had for the first time an opportunity of drawing from the living model.

This is in brief all that is known of Blake's artistic education. That he ever, at the academy or elsewhere, systematically studied painting we do not know; but that he had already begun the practice of water colour for himself is ascertained. So far, however, the course of his training in art schools, and under Basire, was calculated to render him proficient only as a draughtsman and an engraver. He had learned how to draw, and he had mastered besides the practical difficulties of engraving, and with these qualifications he entered upon his career. In 1780 he exhibited a picture in the Royal Academy Exhibition, conjectured to have been executed in water colours, and he continued to contribute to the annual exhibitions up to the year 1808. In 1782 he married Catharine Boucher, the daughter of a market-gardener at Battersea, with whom he lived always on affectionate terms, and the young couple after their marriage established themselves in Green Street, Leicester Fields. Blake had already become acquainted with some of the rising artists of his time, amongst them Stothard, Flaxman, and Fuseli, and he now began to see something of literary society. At the house of the Rev. Henry Mathew, in Rathbone Place, he used to recite and sometimes to sing poems of his own composition, and it was through the influence of this gentleman, combined with that of Flaxman, that Blake's first volume of poetry was printed and published in 1783. From this time forward the artist came before the world in a double capacity. By education as well as native talent, he was pledged to the life of a painter, and these *Poetical Sketches*, though they are often no more than the utterances of a boy, are no less decisive in marking Blake as a future poet.

For a while the two gifts are exhibited in association. To the close of his life Blake continued to print and publish, after a manner of his own, the inventions of his verse illustrated by original designs, but there is a certain period in his career when the union of the two gifts is peculiarly close, and when their service to one another is unquestionable. In 1784 Blake, moving from Green Street, set up in company with a fellow-pupil, Parker, as print-seller and engraver next to his father's house in Broad Street, Golden Square, but in 1787 this partnership was severed, and he established an independent business in Poland Street. It was from this house, and in 1787, that the *Songs of Innocence* were published, a work that must always be remarkable for beauty both of verse and of design, as well as for the singular method by which the two were combined and expressed by the artist. Blake became in fact his own printer and publisher. He engraved upon copper, by a process devised by himself, both the text of his poems and the surrounding decorative design, and to the pages printed from the copper plates an appropriate colouring was afterwards added by hand. The poetic genius already discernible in the first volume

of *Poetical Sketches* is here more decisively expressed, and some of the songs in this volume deserve to take rank with the best things of their kind in our literature. In an age of enfeebled poetic style, when Wordsworth, with more weighty apparatus, had as yet scarcely begun his reform of English versification, Blake, unaided by any contemporary influence, produced a work of fresh and living beauty; and if the *Songs of Innocence* established Blake's claim to the title of poet, the setting in which they were given to the world proved that he was also something more. For the full development of his artistic powers we have to wait till a later date, but here at least he exhibits a just and original understanding of the sources of decorative beauty. Each page of these poems is a study of design, full of invention, and often wrought with the utmost delicacy of workmanship. The artist retained to the end this feeling for decorative effect; but as time went on, he considerably enlarged the imaginative scope of his work, and decoration then became the condition rather than the aim of his labour.

Notwithstanding the distinct and precious qualities of this volume, it attracted but slight attention, a fact perhaps not very wonderful, when the system of publication is taken into account. Blake, however, proceeded with other work of the same kind. The same year he published *The Book of Thel*, more decidedly mystic in its poetry, but scarcely less beautiful as a piece of illumination; *The Marriage of Heaven and Hell* followed in 1790; and in 1793 there are added *The Gates of Paradise*, *The Vision of the Daughters of Albion*, and some other "Prophetic Books." It becomes abundantly clear on reaching this point in his career, that Blake's utterances cannot be judged by ordinary rules. The *Songs of Experience*, put forth in 1794 as a companion to the earlier *Songs of Innocence*, are for the most part intelligible and coherent, but in those intervening works of prophecy, as they were called by the author, we get the first public expression of that phase of his character and of his genius upon which a charge of insanity has been founded. The question whether Blake was or was not mad seems likely to remain in dispute, but there can be no doubt whatever that he was at different periods of his life under the influence of illusions for which there are no outward facts to account, and that much of what he wrote is so far wanting in the quality of sanity as to be without a logical coherence. On the other hand, it is equally clear that no madness imputed to Blake could equal that which would be involved in the rejection of his work on this ground. The greatness of Blake's mind is even better established than its frailty, and in considering the work that he has left we must remember that it is by the sublimity of his genius, and not by any mental defect, that he is most clearly distinguished from his fellows. With the publication of the *Songs of Experience* Blake's poetic career, so far at least as ordinary readers are concerned, may be said to close. A writer of prophecy he continued for many years, but the work by which he is best known in poetry are those earlier and simpler efforts, supplemented by a few pieces taken from various sources, some of which were of later production. The body of Blake's intelligible verse is now made accessible to the public, in Mr W. Rossetti's edition of his works, published in the Aldine series, and to this volume those readers may be referred who desire to know the foundation upon which the poet's fame has been built. But although Blake the poet ceases in a general sense at this date, Blake the artist is only just entering upon his career. In the *Songs of Innocence and Experience*, and even in some of the earlier *Books of Prophecy*, the two gifts worked together in perfect balance and harmony; but at this point the supremacy of the artistic faculty

asserts itself, and for the remainder of his life Blake was pre-eminently a designer and engraver. The labour of poetical composition continues, but the product passes beyond the range of general comprehension; while, with apparent inconsistency, the work of the artist gains steadily in strength and coherence, and never to the last loses its hold upon the understanding. It may almost be said without exaggeration that his earliest poetic work, *The Songs of Innocence*, and nearly his latest effort in design, the illustrations to the *The Book of Job*, take rank among the sanest and most admirable products of his genius. Nor is the fact, astonishing enough at first sight, quite beyond a possible explanation. As Blake advanced in his poetic career, he was gradually hindered and finally overpowered by a tendency that was most serviceable to him in design. His inclination to substitute a symbol for a conception, to make an image do duty for an idea, became an insuperable obstacle to literary success. He endeavoured constantly to treat the intellectual material of verse as if it could be moulded into sensuous form, with the inevitable result that as the ideas to be expressed advanced in complexity and depth of meaning, his poetic gifts became gradually more inadequate to the task of interpretation. The earlier poems dealing with simpler themes, and put forward at a time when the bent of the artist's mind was not strictly determined, do not suffer from this difficulty; the symbolism then only enriches an idea of no intellectual intricacy; but when Blake began to concern himself with profounder problems the want of a more logical understanding of language made itself strikingly apparent. If his ways of thought and modes of workmanship had not been developed with an intensity almost morbid, he would probably have been able to distinguish and keep separate the double functions of art and literature. As it is, however, he remains as an extreme illustration of the ascendancy of the artistic faculty. For this tendency to translate ideas into image, and to find for every thought, however simple or sublime, a precise and sensuous form, is of the essence of pure artistic invention. If this be accepted as the dominant bent of Blake's genius, it is not so wonderful that his work in art should have strengthened in proportion as his poetic powers waned; but whether the explanation satisfies all the requirements of the case or not, the fact remains, and cannot be overlooked by any student of Blake's career.

In 1796 Blake was actively employed in the work of illustration. Edwards, a bookseller of New Bond Street, projected a new edition of Young's *Night Thoughts*, and Blake was chosen to illustrate the work. It was to have been issued in parts, but for some reason not very clear the enterprise failed, and only a first part, including forty-three designs, was given to the world. These designs were engraved by Blake himself, and they are interesting not only for their own merit but for the peculiar system by which the illustration has been associated with the text. Quite recently it has been discovered that the artist had executed original designs in water colour for the whole series, and these drawings, 537 in number, form one of the most interesting records of Blake's genius. Mr Gilchrist, the painter's careful and sympathetic biographer, in commenting upon the engraved plates, regrets the absence of colour, "the use of which Blake so well understood, to relieve his simple design and give it significance," and an examination of the original water colour drawings fully supports the justice of his criticism. Soon after the publication of this work Blake was introduced by Flaxman to the poet Hayley, and in the year 1801 he accepted the suggestion of the latter, that he should take up his residence at Felpham in Sussex. The mild and amiable poet had planned to write a life of Cowper, and for the

illustration of this and other works he sought Blake's help and companionship. The residence at Felpham continued for three years, partly pleasant and partly irksome to Blake, but apparently not very profitable to the progress of his art. One of the annoyances of his stay was a malicious prosecution for treason set on foot by a common soldier whom Blake had summarily ejected from his garden; but a more serious drawback was the increasing irritation which the painter seems to have experienced from association with Hayley. In 1804 Blake returned to London, to take up his residence in South Moulton Street, and as the fruit of his residence in Felpham, he published, in the manner already described, the prophetic books called the *Jerusalem*, *The Emanation of the Giant Albion*, and *Milton*. The first of these is a very notable performance in regard to artistic invention. Many of the designs stand out from the text in complete independence, and are now and then of the very finest quality.

In the years 1804-1805 Blake executed a series of designs in illustration of Blair's *Grave*, of much beauty and grandeur, though showing stronger traces of imitation of Italian art than any earlier production. These designs were purchased from the artist by an adventurous and unscrupulous publisher, Cromek, for the paltry sum of £21, and afterwards published in a series of engravings by Schiavonetti. Despite the ill treatment Blake received in the matter, and the other evils, including a quarrel with his friend Stothard as to priority of invention of a design illustrating the *Canterbury Pilgrims*, which his association with Cromek involved, the book gained for him a larger amount of popularity than he at any other time secured. Stothard's picture of the *Canterbury Pilgrims* was exhibited in 1807, and in 1809 Blake, in emulation of his rival's success, having himself painted in water colour a picture of the same subject, opened an exhibition, and drew up a *Descriptive Catalogue*, curious and interesting, and containing a very valuable criticism of Chaucer.

The remainder of the artist's life is not outwardly eventful. In 1813 he formed, through the introduction of George Cumberland of Bristol, a valuable friendship with Mr John Linnell and other rising water colour painters. Amongst the group Blake seems to have found special sympathy in the society of Varley, who, himself addicted to astrology, encouraged Blake to cultivate his gift of inspired vision; and it is probably to this influence that we are indebted for several curious drawings made from visions, especially the celebrated "ghost of a flea" and the very humorous portrait of the builder of the Pyramids. In 1821 Blake removed to Fountain Court, in the Strand, where he died 1827. The chief work of these last years was the splendid series of engraved designs in illustration of the book of Job. Here we find the highest imaginative qualities of Blake's art united to the technical means of expression which he best understood. Both the invention and the engraving are in all ways remarkable, and the series may fairly be cited in support of a very high estimate of his genius. None of his works are without the trace of that peculiar artistic instinct and power which seizes the pictorial element of ideas, simple or sublime, and translates them into the appropriate language of sense; but here the double faculty finds the happiest exercise. The grandeur of the theme is duly reflected in the simple and sublime images of the artist's design, and in the presence of these plates we are made to feel the power of the artist over the expressional resources of human form, as well as his sympathy with the imaginative significance of his subject.

A life of Blake, with selections from his works by Alexander Gilchrist, was published in 1863; in 1868 Mr Swinburne published a critical essay on his genius re-

taskable for a full examination of the Prophetic Books, and still more recently Mr William Rossetti has published a memoir prefixed to an edition of the poems. (J. A. C.)

BLANC, MONT, the highest, and in other respects one of the most remarkable mountains in Europe, is situated in that division of the great Alpine system known as the Pennine Alps, in 45° 49' 58" N. lat. and 6° 51' 54" E. long. It rises almost in the shape of a pyramid to the height of 15,780 feet, and is visible at a distance of 130 miles to the west. The mass of the mountain is composed of granite, covered with strata of schists and limestones. To the N.E. lies the beautiful vale of Chamouni, and on the S.W. the Allée Blanche. Of the numerous glaciers that send their ice-streams down its sides the most remarkable is the Mer de Glace, which winds down its northern slope towards Chamouni, and gives birth to the River Arve. The ascent of Mont Blanc was first accomplished in 1786 by a guide named Jacques Balmat, who shortly afterwards led Dr Paccard, a local physician, to the summit, and thus gave him the honour of being the first person of scientific education to make known the possibility of the undertaking. De Saussure, the naturalist, ascended in the following year, and when the Italian naturalist Imperiale de Sant'Angelo made the ascent in 1840 he had been preceded by thirty-three known travellers. The whole journey to the top and back can now be accomplished in 50 or 60 hours; but in general the view can hardly be said to be worth the fatigue, the extreme height of the position, even when the outlook is unclouded, rendering the prospect indistinct. For authorities and maps, see ALPS, vol. i. pp. 635-6.

BLANE, SIR GILBERT, a distinguished physician, was born at Blansfield in Ayrshire, in 1749, and died in London in 1834. He was educated at Edinburgh University, and shortly after his removal to London became private physician to Lord Rodney, whom he accompanied to the West Indies. Through his skill and exertions the health of the seamen on board the fleet remained comparatively unaffected by the climate; and on his return home he embodied the results of his experience in a treatise *On the Diseases of Seamen*, 1783. He rose rapidly to fame, acquired an extensive practice, and in 1812 was appointed physician in ordinary to the Prince of Wales, with the rank of baronet. When at the head of the Navy Board of Health, an office he held for some years, he introduced many useful measures for securing the health of seamen during long voyages. Of his numerous works the most important is the *Elements of Medical Logic*, 1819.

BLANÈS, a city of the province of Gerona in Spain, at the mouth of the River Tordera, defended by a castle. The population, 5900 in number, are principally employed in the fisheries and navigation. Lace is manufactured by the women. Long. 2° 51' E., lat. 41° 42' N.

BLARNEY, a small village of Ireland, in the county of Cork, about 5 miles from that city, chiefly celebrated as giving name to a peculiar kind of eloquence, alleged to be characteristic of the natives of Ireland. The "Blarney Stone," the kissing of which is said to confer this faculty, is pointed out within the castle.

BLASPHEMY means literally defamation or evil speaking, but is more peculiarly restricted to an indignity offered to the Deity by words or writing. The common law of England treats blasphemy as an indictable offence. All blasphemies against God, as denying his being, or providence, all contumelious reproches of Jesus Christ, all profane scoffing at the Holy Scriptures, or exposing any part thereof to contempt or ridicule, are punishable by the temporal courts with fine, imprisonment, and also infamous corporal punishment. The Act 1 Edw. VI. c. 1 (repealed 1 Mary, c. 2, and revived 1 Eliz. c. 1), enacts that persons reviling the sacrament of the Lord's supper, by contemptuous

words or otherwise, shall suffer imprisonment. Persons denying the Trinity were deprived of the benefit of the Act of Toleration by 1 Will. III. c. 18. The 9 and 10 Will. III. c. 32, enacts that if any person, educated in or having made profession of the Christian religion, should by writing, preaching, teaching, or advised speaking, deny any one of the persons of the Holy Trinity to be God, or should assert or maintain that there are more gods than one, or should deny the Christian religion to be true, or the Holy Scriptures to be of divine authority, he should, upon the first offence, be rendered incapable of holding any office or place of trust, and for the second incapable of bringing any action, of being guardian or executor, or of taking a legacy or deed of gift, and should suffer three years' imprisonment without bail. It has been held that a person offending under the statute is also indictable at common law (*Rex v. Carlisle*, where Mr Justice Best remarks, "In the age of toleration, when that statute passed, neither churchmen nor sectarians wished to protect in their infidelity those who disbelieved the Holy Scriptures.") The 53 Geo. III. c. 160, excepts from these enactments "persons denying as therein mentioned respecting the Holy Trinity," but otherwise the common and statute law on the subject remains as stated. In the case of *Rex v. Woolston* (2 Geo. II.) the court declared that they would not suffer it to be debated whether to write against Christianity in general was not an offence punishable in the temporal courts at common law, but they did not intend to include disputes between learned men on particular controverted points. The law against blasphemy has not recently been in active operation. In 1841, Moxon was found guilty of the publication of a blasphemous libel (*Shelley's Queen Mab*), the prosecution having been instituted by Hetherington, who had previously been condemned to four months' imprisonment for a similar offence, and wished to test the law under which he was punished. In the case of *Cowan v. Milbourn*, in 1867, the defendant had broken his contract to let a lecture-room to the plaintiff, on discovering that the intended lectures were to maintain that "the character of Christ is defective, and his teaching misleading, and that the Bible is no more inspired than any other book," and the Court of Exchequer held that the publication of such doctrine was blasphemy, and the contract therefore illegal. On that occasion the court reaffirmed the dictum of C. J. Hale, that Christianity is part of the laws of England. The Commissioners on Criminal Law (sixth report) remark, that "although the law forbids all denial of the being and providence of God or the Christian religion, it is only when irreligion assumes the form of an insult to God and man that the interference of the criminal law has taken place."

Profane cursing and swearing is made punishable by 19 Geo. II. c. 21, which directs the offender to be brought before a justice of the peace, and fined 5 shillings, 2 shillings, or 1 shilling, according as he is a gentleman, below the rank of gentleman, or a common labourer, soldier, &c.

By the law of Scotland, as it originally stood, the punishment of blasphemy was death. By an Act passed in the first parliament of Charles II., whoever, "not being distracted in his wits," should curse God or any person of the blessed Trinity was punishable with death; and by a statute of King William's reign (1695, c. 11), any person reasoning against the being of God, or any person of the Trinity, or the authority of the Holy Scriptures, or the providence of God in the government of the world, was to be imprisoned for the first offence until he should give public satisfaction in sackcloth to the congregation, to be punished more severely for the second offence, and for the third doomed to death; but by 6 Geo. IV. c. 47, amended by 7 Will. IV. and 1 Vict. c. 5, blasphemy was made punishable by fine or imprisonment or both. (M. S.)

BLASTING is the process by which portions of rock, or other hard substances, are disintegrated by means of an explosive agent, such as gunpowder. It is largely resorted to in quarrying, tunnelling, and mining operations.

Of late years there has been rapid advance in the art, through the discovery of new explosives, through improvements in appliances for firing, &c.; so that the older method of blasting has, in many instances, given place to a more complex system, with which much better results are obtained. The simpler process may be described thus. When a blast is to be made, a hole to receive powder is first bored in the rock; such holes vary in diameter from  $\frac{1}{2}$  inch to  $2\frac{1}{2}$  inches, in depth from a few inches to many feet, and in direction from the vertical to the horizontal. The borer, or jumper, with which the hole is made is a steel pointed drill; it is struck by a hammer, and is turned partly round after each blow, to make the hole cylindrical. One man may do all this alone, but generally, in the case of larger holes, a man, in sitting posture, directs the jumper, supplies the hole with water, and clears out the powdered stone at intervals with a scraper, while another man, or two, or three, are engaged in striking. A small rope of straw or hemp is twisted round the jumper at the orifice of the hole to prevent squirting up of the water. In the case of soft rock a loaded drill is sometimes used, which acts merely by its own weight. On the other hand, in substances like pyrites, or compact magnetic iron ore, which cannot be penetrated with steel drills, holes for blasting may be made by the gradual action of an acid (commonly muriatic) admitted through a vertical glass tube. When a sufficient depth is reached, the hole is cleaned and dried, and a charge of powder put in. A small taper rod of copper, the needle or nail, is inserted so as to reach to the bottom of the charge; then the rest of the hole is filled up with some such material as dry sand or tough clay, which forms the "tamping" or wadding, and which is firmly rammed down in small quantities successively by means of the tamping bar, a copper-faced punch of such thickness that it nearly fills the hole, and having a groove in it to receive the nail. This operation requires great care, because of the danger of eliciting sparks through collision. The hole being now fully charged, the nail is withdrawn, leaving a small vent hole, into which is then introduced an oaten straw filled with powder (or a series of such). To this is attached a slow match of paper steeped in saltpetre. The match is touched with fire; the alarm is given to retire to a safe distance; and presently the explosion takes place, the rock opening with a sharp report, and fragments of stone being often shot into the air in all directions. An improvement on this method of firing consists in the employment of Bickford's patent fuse, which may be described as a perforated rope or hose containing an inflammable composition. A suitable length of fuse is placed in contact with the charge before tamping, and carried up to the mouth of the hole. On being lighted it burns at the rate of 2 to 3 feet per minute, giving the miners an opportunity to escape before explosion. A water-tight form of the fuse is often used in submarine blasting,—the shot or charge being then made up in cartridge form.

Blasting, however, is often done on a much larger scale than that just indicated. As an example of the large blasts, or "mines," where great blocks of rock have to be removed at once, we might take some of the operations carried on at the Holyhead quarries a number of years ago for the harbour works. An entrance gallery, 5 feet 6 inches by 3 feet 6 inches was first driven from the face of the rock (hard quartzose schist), an extent of 34 feet, where a shaft, 3 feet 6 inches by 3 feet 6 inches, was sunk to a depth of 14 feet. From this, level galleries were

driven some distance right and left, with four short headings, at intervals, returning towards the face of the rock and terminating in chambers for the charges. The four charges, amounting in all to 12,000 lb of powder, were enclosed in canvas bags coated with tar. They were calculated at the rate of 1 lb of powder to 3 tons of rock. For tamping a stiff red clay was used; it was well rammed up close to the bags of powder (leaving a small air space round these), and continued to the mouth of the gallery. The charges were fired simultaneously by means of platinum wire heated by a Grove's battery. The total quantity of rock removed was about 40,000 tons; it was separated into various sized blocks. Similarly, the Rounddown Cliff at Dover was overthrown in 1843 for railway purposes by 18,500 lb of powder, in three separate charges, fired simultaneously from a Voltaic battery; a saving of £7000 was thus effected by the South-Eastern Railway Company.

In reviewing recent developments of the art of blasting, the application of machinery in the boring of rocks naturally claims some attention. A good rock-boring machine, at least where used in connection with simultaneous firing by electricity, ensures considerable economy in time and labour over the old method of hand-boring. Of such machines, in which the jumper is repeatedly driven against the rock by compressed air or steam, being also made to rotate slightly at each blow, there are several varieties; the Burleigh rock drill is one of the best. It was used in the Hoosac tunnel in Massachusetts from 1869; and the last 5220 yards were completed with only eight of these machines. The rock was gneiss alternating with quartz. With hand-boring, the progress per minute was about 16 yards; with the Burleigh drill it was 48 yards, and the work was about one-third cheaper. According to *Engineering*, the cost of the Mont Cenis tunnel was £195 per linear yard; that of the Hoosac tunnel, notwithstanding much harder rock, only £180. In the recent large blastings at Hellgate, New York, the Burleigh machines also established their superiority, and came to be used exclusively. Among other boring-machines may be mentioned the "Diamond" drill, and the systems of Law, Ingersoll, McKean, Bergstrom, Sachs, Doering.

The general properties of ordinary blasting-powder are well known; it requires to be kept dry, and when dry, a spark of fire will cause it to explode. Various efforts have of late years been made towards the employment of more powerful explosive agents for blasting purposes. The violent oxidizing power of chlorate of potash marked it out as available for explosive mixtures; and sundry preparations containing this substance have been made (some of them highly dangerous). *Horsley's Blasting-Powder*, consisting of powdered nut galls and chlorate, may be taken as a type of these mixtures, and as the safest of them. It is both more violent and more rapid in explosion than ordinary blasting-powder, and does not give off any smoke or unpleasant smell when it explodes. It must be kept dry, and it is liable to explode through friction; the expensiveness of its ingredients is also a drawback. *Gun-cotton* was discovered by Schönbein in 1846, but owing to disastrous accidents occurring in the three years which followed, it was abandoned in this country and in France for sixteen years. Through the researches, meanwhile, of an Austrian, Baron von Lenk, it again came into notice in 1864, and a Government committee investigated the merits of the gun-cotton twist or rope made according to the Austrian system. For blasting hard rock its general superiority in effect to powder was recognized; and the absence of smoke, where the resistance opposed to the gun-cotton was sufficient to develop its full explosive force, was specially remarked upon. The want of rigidity of the material was objectionable; and several accidents

occurred, through violent friction of the twist, when miners had attempted to drive home a jammed charge. A considerable gain was secured by the invention of *compressed gun-cotton* by Professor Abel in 1868. In this form the explosive occupied less than half the space of the rope charges, and the smooth, hard exterior of the cylindrical charges rendered the operation of loading comparatively easy. The compressed charges, moreover, did not burn with the explosive violence of spun gun-cotton even when confined in the ordinary packing cases. Among further improvements may be noted the cheapening of the material by use of cotton waste, instead of the long staple cotton of high quality that was used in the Austrian manufacture. In 1868 Mr. E. O. Brown discovered that (like nitroglycerine)<sup>1</sup> compressed gun-cotton was susceptible of violent explosion through the agency of a detonation, as well as in the ordinary way. This was important, especially for submarine operations and works of demolition; for the strong confinement which was always necessary in the other case could be dispensed with; indeed, with some waste of power, the substance might be exploded completely unconfined. Gun-cotton is not affected in its explosiveness by cold; and it can be kept any length of time without deterioration in the damp and perfectly unignitable state. The formula that has been assigned for the most explosive gun-cotton is  $C_8H_7N_3O_8$ .

In 1864 Mr. Nobel's researches called attention to the application of *nitroglycerine* (discovered by Sobrero in 1846) as an explosive agent. He first showed that the effect of gunpowder was considerably increased through impregnation with it; and later, that the liquid itself, which burns slowly in the air on application of a flame with a common fuse, could be exploded by an initiative detonation,—confinement by tamping being then unnecessary. In its pure state it was soon proved to be the most powerful explosive yet known; its destructive force is about ten times that of gunpowder. Its liquid form, high specific gravity, and insolubility in water, are valuable properties in some cases, as in blasting under water or in wet holes. It freezes at a comparatively high temperature ( $40^\circ$  Fahr.); but the opinion, formed from several grave accidents, that it was more susceptible of detonation in the frozen than in the liquid state, has been shown to be contrary to fact. When frozen it is more liable to recklessly rough usage. The liquid state of nitroglycerine, on the other hand, constitutes a very serious defect, owing to its tendency to leak from vessels in which it is carried, or from the blast-hole, through fissures in the rock,—resulting in unexpected explosions, it may be, through some slight concussion. Mr. Nobel's ingenious device for rendering nitroglycerine temporarily inexplorable, by dissolving it, viz., in wood spirit, is only partially successful. Nitroglycerine has been extensively used in various mining districts, especially in California. After some terrible accidents, which occurred in 1866-7, its use in England was placed under severe restrictions.

Impressed with the serious disadvantages of this explosive, Mr. Nobel was led to the important observation that its readiness to explode by detonation is not diminished, but rather favoured, by mixture with solid substances, in themselves quite inert; and the dilution did not materially detract from the great superiority of nitroglycerine over gunpowder. In 1867 he brought before the public the substance appropriately called *dynamite*, which is one of the safest, most powerful, and most convenient explosives for industrial purposes. It consisted of seventy-five parts of nitroglycerine held absorbed by twenty-five

parts of a porous, infusorial, silicious earth, known in Germany as "Kieselguhr." Other absorbents have been employed (precipitated kaolin, tripoli, precipitated alumina, sugar, &c.), but none of them are equal to kieselguhr in power of retaining oil. Dynamite is furnished to the trade in the form of small cylindrical cartridges, in which the material, consolidated by pressure, is enclosed in a single wrapping of parchment paper. It requires no tamping, and can be exploded by detonation under water. It is slow to catch fire, but burns rather fiercely when fired; and if the quantities are large, or under confinement, an explosion may finally ensue. The trade in it has developed rapidly; thus, while only 11 tons of it were sold in 1867, the quantity rose to 3120 tons in 1874.

In the preparation known as *lithofracteur*, which came into notice during the Franco-German War, nitroglycerine is used in considerably smaller proportions than in dynamite; and the kieselguhr of the latter is partly replaced by materials forming of themselves a feebly explosive mixture. Its properties are very similar to those of dynamite, but it is less powerful.

The less known ammonia powder, invented by Ohlson and Norbin, is much stronger than lithofracteur, and even surpasses dynamite. Its only drawback is the hygroscopic nature of its chief ingredient, which is nitrate of ammonium; but otherwise it is a very superior blasting agent. Numerous other explosives have been tried in blasting, but those we have named are amongst the most important.

In a recent paper to the Society of Arts, Mr. Nobel has discussed the relative power of several blasting agents. He finds that when their ballistic power is compared bulk for bulk, the substances experimented with rank as follows:—Nitroglycerine, 100; ammonia powder, 80; dynamite (No. 1), 74; lithofracteur, 53; gun-cotton, 45; Curtis and Harvey's blasting-powder (fired by detonator), 17.5. While these figures show the great superiority of nitroglycerine, there are practical circumstances which bring it and dynamite nearly on an equality. Thus, to get the full benefit of a blast there should be no air-space round the charge. Now, from the danger (as we have seen) of nitroglycerine leaking through imperceptible fissures in a rock, rigid cartridges are required for it, and these always involve a considerable air chamber, whereas dynamite, being highly plastic, can be easily compressed so as to exclude all empty space. The cartridges of compressed gun-cotton are also liable, of course, to the objection just noticed.

Where rapid destruction is to be accomplished there is a saving of labour, of tools, and of time by use of the new explosive agents (such as dynamite or gun-cotton). Their shattering and splitting effect in hard rock is much greater, but in quarrying, the rock is generally not thrown out by them to the same extent. Where a moderate cleaving or splitting effect is desired, with as little local action as possible, gunpowder is best, as in raising large blocks of slate; also where great displacing action is required. In submarine blasting of soft rocks the violent explosives disintegrate the rock into a plastic mass within a limited area, but do not shatter or rend it to any great distance.

As regards comparative safety, there is no doubt that modern explosives offer a relative immunity from the danger arising from fire, to which gunpowder is subject. Neither dynamite nor gun-cotton can be fired by a spark, and if accidentally fired by a flame, they allow reasonable chances of escape. On the other hand, accidents have often happened in the thawing of nitroglycerine preparations when frozen,—a process that requires great care, and for which suitable warming-pans are provided. But miners are slow to understand that a cartridge which firing does not set off cannot be slowly heated with the same impunity; hence they will roast the preparations near a

<sup>1</sup> It was found, in the course of these inquiries, that all explosive compounds, even including gunpowder, are susceptible of explosion through a detonation, though the nature and force of the detonation vary considerably with different explosive substances.

fire, or on hot cluders, or in other ways really dangerous. Gun-cotton and dynamite prove much safer than nitroglycerine as regards exploding through concussion. There is not, however (Mr Nobel thinks), that amount of difference between the sensitiveness of nitroglycerine and dynamite which the latter substance generally receives credit for. The main danger of nitroglycerine arose from the sensitiveness to concussion which it acquired through contact with a hard, metallic, strongly vibrating substance, such as the tin canisters in which it was contained. The main safety of dynamite is derived from the absence of any hard vibrating material in immediate contact with the nitroglycerine it contains.

As regards danger from concussion in manufacture and transit, gun-cotton ranks first; but in the hands of miners, the case is reversed, through the rough usage of gun-cotton charges, where, e.g., they are found too large for a bore-hole, for gun-cotton is well known to explode with a blow. The danger most dreaded in modern explosives is from their supposed liability to chemical decomposition productive of heat, which sometimes leads to ignition and explosion. This decomposition is generally due to the presence of acid (chiefly nitric and hyponitric), which every nitrated compound has a strong tendency to retain. From the ease with which the acid can be washed out from nitroglycerine, both it and dynamite show much greater chemical stability than gun-cotton. Most cases of spontaneous combustion of the latter have probably arisen either from imperfect washing, or from drying at too high a temperature (by which hyponitric acid is set free).

Complaints have often been made of the poisonous fumes given off by the new explosives. Where this occurs, it is probably due to an injudicious use of the substance, resulting in imperfect explosion. If a dynamite cartridge partly burns instead of exploding, the temperature is much lower, and fumes of hyponitric acid are given off, which could not escape decomposition at the higher temperature of perfect explosion. The general mistake consists in not securing carefully the detonator cap to the fuse, and especially the fuse to the cartridge.

*Blasting by Electricity.*—It is known that electricity has a thermal effect on wire through which it passes; and the amount of heat produced in any part of the circuit is proportional to the resistance in that part. Thus a piece of wire of small section and conductivity may be made incandescent by a current. On this principle platinum is sometimes employed to fire blasting charges. In making a fuse of this sort, two insulated copper wires are twisted together for a length of about 6 inches, leaving the extremities free for about half an inch, and separated the same distance. A fine platinum (or iron) wire is stretched across this interval, metallic contact being established with the copper. The other ends of the fuse are connected with a battery. Platinum fuses are not much to be relied on for simultaneous blasting of several charges by one battery; for some of the fuses may take a little more time to reach the exploding temperature than others, and thus, as soon as one explodes, the connection between the others and the battery is broken. The batteries to be used with them are such as generate electricity of great quantity. The Bunsen and Leclanché batteries, in some of their varieties, are well suited for this. Twelve cells of Highton's battery will melt a piece of platinum wire over an inch long.

There is, however, another class of fuses, offering certain advantages over those just referred to, in which the spark produced by electricity of tension is the means used to effect the explosion. It might naturally be thought that an electric spark must inevitably cause explosion in a mass of powder or like substance through which it is made to pass; but this is not the case. The heating

power of the spark is often insufficient for explosion. The duration of an induction spark is about the *millionth* of a second; whereas, to ignite powder, it is necessary that a spark should exist for at least the *three hundredth* part of a second. By interposing, however, a suitable priming composition in the interval which the spark is to cross, and in contact with the charge, explosion may be thus effected. In preparing such a composition, the properties of the ingredients as regards conductivity, inflammability, and explosiveness have to be nicely adjusted, according to the degree of tension of the electricity employed. The composition selected by Professor Abel for his fuses is an intimate mixture of subsulphide of copper, subphosphide of copper, and chlorate of potassium. It is a mixture which conducts, but conducts with difficulty, and the fuses made with it are very effective. There are several other varieties, e.g., Ebner's fuse, where the priming consists of a mixture of sulphuret of antimony, chlorate of potash, and graphite.<sup>1</sup>

For generating electricity of tension with the Voltaic battery, Leclanché's battery is, again, one of the most suitable. The elements of this battery consist of a rod of carbon placed in a porous cell and tightly packed round with a mixture of peroxide of manganese and coke; the porous cell is placed in a vessel containing a plate of zinc, which forms the electro-positive element, and a solution of sal-ammoniac is used as the exciting liquid. There are some forms of battery for the same purpose so arranged that the contact of the elements with the liquid takes place only at the time of firing; such are those of Wollaston, Ruhmkorff, and Trouvé

Frictional electricity is the kind generally adopted by military authorities in firing charges,—the machines for generating it being easily made, simple, portable, and powerful. Bornhardt's frictional machine has found extensive use in Austria in ordinary blasting operations. It is contained in a small metallic case, and consists of a disc of ebonite, which can be rotated between two cushions, charging a small Leyden jar placed near it. On pressing a little button from the outside, connection is made between the two coatings of the jar in such a way that the charge is sent through two wires by which the box is connected with the fuse, or fuses, at a distance. Some absorbent of moisture is kept within the box, and it is necessary to see that the machine be kept as warm and dry as possible.

Experiments were made by Messrs Wheatstone and Abel, a number of years ago, with Armstrong's hydroelectric machine, as a source of electricity for exploding charges of powder. They state that in very extensive mining operations, where a great many charges have to be fired simultaneously, and provided all the necessary appliances for success are at hand, the machine could be used very effectively. It is a powerful source of electricity of high tension. There are serious objections, however, to its general use.

Electro-magnetic induction currents (such as are developed in Ruhmkorff's coil) were first applied, and successfully, by Colonel Verdu, a Spanish officer, in 1853. The induction discharge, unlike that of a Leyden battery, is much enfeebled by successive solutions of continuity, so that not more than four mines in a single circuit could certainly be exploded on this system. But M. Savare made an improvement by interposing the fuses in branches of the principal circuit. The mine nearest the apparatus explodes first; and, owing to the abrupt separation of the wires, the current can no longer pass through this branch; thus the electric action is augmented in the other branches, and in a similar manner the explosions necessarily take

<sup>1</sup> In one form of fuse employed with dynamite, there is connected with the priming just mentioned some mercuric fulminate and loose gun-cotton.



place in them, and that with a rapidity almost instantaneous. This is also a more efficient plan than that of employing a rheotome for changing the direction of the current, so as to bring wires connected with one or more charges successively into the circuit. The Ruhmkorff coil is, however, objectionable for its delicacy and the maintenance of batteries in connection with it. In experiments made by Messrs Wheatstone and Abel, a powerful magneto-electric machine was found very limited in its power of igniting several charges arranged in succession in one circuit (it only ignited three at most, with certainty); but on M. Savare's plan of arranging the charges in divided circuits, the simultaneous ignition of twenty-five charges was repeatedly effected; on several occasions as many as forty. By this plan each charge was connected with a separate branch attached to the main line, and their connection with earth established by means of uncovered copper wire wound round an iron stake driven in the ground. Another form of instrument, devised by Wheatstone, consists of six small magnets, to the poles of which are fixed soft iron bars surrounded by coils of insulated wire; the coils of all the magnets are united together, so as to form, with the external conducting wire and the earth, a single circuit. An axis carries six soft iron armatures, in succession, before each of the coils. With this apparatus twenty-five charges were frequently fired in divided circuit, so rapidly that the effect on the ear was as of one explosion, only of slightly longer duration than when the large magnet was employed. The Markus apparatus, largely used in Germany, is on the same principle.

Siemens's dynamo-electric machine, in which electro-magnets are employed, is a very useful machine for simultaneous firing. It is found that the residual

magnetism left in the coils of electro-magnets, after a current from even a single Voltaic cell has been once sent through them, is always sufficient to have the necessary inductive action on the armature. This inductive action, though very weak at first, generates slight alternating currents in the armature, which are by means of a commutator caused to flow always in one direction through the coils of the electro-magnet, thus increasing the magnetism in the core, which, in its turn, increases the inductive action, causing stronger and stronger currents to be generated in the armature. This action and reaction goes on till the limit of magnetic capacity of the core is reached, and if the coil of the armature be then suddenly connected with the line leading to a fuse, a very powerful current is transmitted. In Breguet's exploder (in which a bar of soft iron is suddenly separated from the armature of a magnet bearing two induction coils) a special arrangement gives rise to an extra-current, and considerably increases the intensity of the current. M. Breguet has lately utilized in this apparatus the new and powerful laminated magnets constructed by M. Jamin. Gramme's machines are also effective in exploding charges, but their volume and high price are against a large use of them industrially.

For more detailed information on the recent developments of blasting, reference may be made to Spou's *Dictionary of Engineering*, art. "Boring and Blasting;" *Professional Papers of the Corps of Royal Engineers*, vols. vii., x., xxii.; *Transactions of the Society of Engineers*, 1869 and 1871; *Proceedings of South Wales Institute of Mining Engineers*, vol. viii., No. 5, vol. ix., Nos. 1 and 2; *Dingler's Polytechnisches Journal*, Oct. 1, 1874; *Annales de Chimie et de Physique*, May 1875; *Journal of the Society of Arts*, May 28, 1875. (A. R. M.)

## BLEACHING

**B**LEACHING is the process of whitening or depriving objects of colour, an operation incessantly in activity in nature by the influence of light, air, and moisture. The art of bleaching, of which we have here to treat, consists in inducing the rapid operation of whitening agencies, and as an industry it is mostly directed to cotton, linen, silk, wool, and other textile fibres, but it is also applied to the whitening of paper-pulp, bees-wax, and some oils and other substances. The term bleaching is derived from the Anglo-Saxon *blaccan* to bleach, or to fade, from which also comes the cognate German word *bleichen*, to whiten or render pale. Bleachers, down to the end of last century, were known in England as "whiteters," a name obviously derived from the nature of their calling.

The operation of bleaching must from its very nature be of the same antiquity as the work of washing textures of linen, cotton, or other vegetable fibres. Clothing repeatedly washed, and exposed in the open air to dry, gradually assumes a whiter and whiter hue, and our ancestors cannot have failed to notice and take advantage of this fact. Scarcely anything is known with certainty of the art of bleaching as practised by the nations of antiquity. Egypt in early ages was the great centre of textile manufactures, and her white and coloured linens were in high repute among contemporary nations. As a uniformly well-bleached basis is necessary for the production of a satisfactory dye on cloth, it may be assumed that the Egyptians were fairly proficient in bleaching, and that still more so were the Phœnicians with their brilliant and famous purple dyes. We learn, from Pliny, that different plants, and likewise the ashes of plants, which no doubt contained alkali, were employed as detergents. He mentions particularly the *Struthium* as much used for bleaching

in Greece, a plant which has been identified by some with *Gypsophila Struthium*. But as it does not appear from Sibthorp's *Flora Græca*, published by Sir James Smith, that this species is a native of Greece, Dr Sibthorp's conjecture that the *Struthium* of the ancients was the *Saponaria officinalis*, a plant common in Greece, is certainly more probable.

In modern times, down to the middle of the 18th century, the Dutch possessed almost a monopoly of the bleaching trade, although we find mention of bleach-works at Southwark near London as early as the middle of the 17th century. It was customary to send all the brown linen, then largely manufactured in Scotland, to Holland to be bleached. It was sent away in the month of March, and not returned till the end of October, being thus out of the hands of the merchant more than half a year.

The Dutch mode of bleaching, which was mostly conducted in the neighbourhood of Haarlem, was to steep the linen first in a waste lye, and then for about a week in a potash lye poured over it boiling hot. The cloth being taken out of this lye, and washed, was next put into wooden vessels containing butter-milk, in which it lay under a pressure for five or six days. After this it was spread upon the grass, and kept wet for several months, exposed to the sunshine of summer.

In 1728 James Adair from Belfast proposed to the Scotch Board of Manufactures to establish a bleachfield in Galloway; this proposal the board approved of, and in the same year resolved to devote £2000 as premiums for the establishment of bleachfields throughout the country. In 1732 a method of bleaching with kelp, introduced by R. Holden, also from Ireland, was submitted to the board; and with their assistance Holden established a bleachfield for prosecuting his process at Pitkerro, near Dundee,

The bleaching process, as at that time performed, was very tedious, occupying a complete summer. It consisted in steeping the cloth in alkaline lyes for several days, washing it clean, and spreading it upon the grass for some weeks. The steeping in alkaline lyes, called *ducking*, and the bleaching on the grass called *crofting*, were repeated alternately for five or six times. The cloth was then steeped for some days in sour milk, washed clean, and crofted. These processes were repeated, diminishing every time the strength of the alkaline lye, till the linen had acquired the requisite whiteness.

For the first improvement in this tedious process, which was faithfully copied from the Dutch bleachfields, manufacturers were indebted to Dr Francis Home of Edinburgh, to whom the Board of Trustees paid £100 for his experiments in bleaching. He proposed to substitute water acidulated with sulphuric acid for the sour milk previously employed, a suggestion made in consequence of the new mode, of preparing sulphuric acid, contrived some time before by Dr Roebuck, which reduced the price of that acid to less than one-third of what it had formerly been. When this change was first adopted by the bleachers, there was the same outcry against its corrosive effects as arose when chlorine was substituted for crofting. A great advantage was found to result from the use of sulphuric acid, which was that a souring with sulphuric acid required at the longest only twenty-four hours, and often not more than twelve; whereas, when sour milk was employed, six weeks, or even two months, were requisite, according to the state of the weather. In consequence of this improvement, the process of bleaching was shortened from eight months to four, which enabled the merchant to dispose of his goods so much the sooner, and consequently to trade with less capital.

No further modification of consequence was introduced in the art till the year 1787, when a most important change was initiated by the use of chlorine, an element which had been discovered by Scheele in Sweden about thirteen years before. Berthollet repeated the experiments of Scheele in 1785, and by the prosecution of further investigations he added considerably to the facts already known. He showed that this substance (called by Scheele *dephlogisticated muriatic acid*) is a gas soluble in water, to which it gives a yellowish green colour, an astringent taste, and the peculiar smell by which the body is distinguished.

The property which this gas possesses of destroying vegetable colours, led Berthollet to suspect that it might be introduced with advantage into the art of bleaching, and that it would enable practical bleachers greatly to shorten their processes. In a paper on dephlogisticated muriatic acid, read before the Academy of Sciences at Paris in April 1785, and published in the *Journal de Physique* for May of the same year (vol. xxvi. p. 325), he mentions that he had tried the effect of the gas in bleaching cloth, and found that it answered perfectly. This idea is still further developed in a paper on the same substance, published in the *Journal de Physique* for 1786. In 1786 he exhibited the experiment to Mr James Watt, who, immediately upon his return to England, commenced a practical examination of the subject, and was accordingly the person who first introduced the new method of bleaching into Great Britain. We find from Mr Watt's own testimony that chlorine was practically employed in the bleachfield of his father-in-law, Mr Macgregor, in the neighbourhood of Glasgow in March 1787. Shortly thereafter the method was introduced at Aberdeen by Messrs Gordon, Barron, and Co., on information received from M. de Saussure through Professor Copland of Aberdeen. Mr Thomas Henry of Manchester was the first to bleach with chlorine in the Lancashire district, and to his independent investigations several of the

early improvements in the application of the material were due.

No very great amount of success, however, attended the efforts to utilize chlorine in bleaching operations till the subject was taken up by Mr Tennant of Glasgow. He, after a great deal of most laborious and acute investigation, hit upon a method of making a saturated liquid of chloride of lime, which was found to answer perfectly all the purposes of the bleacher. This was certainly a most important improvement, without which, the prodigious extent of business carried on by some bleachers could not possibly have been transacted. Such was the acceleration of processes effected by the new method that, it is stated, a bleacher in Lancashire received 1400 pieces of gray mullin on a Tuesday, which on the Thursday immediately following were returned bleached to the manufacturers, at the distance of sixteen miles, and were packed up and sent off on that very day to a foreign market.

In the year 1798 Mr Tennant took out a patent for his new invention, and offered the use of it to practical bleachers, for a fair and reasonable portion of the savings made by its substitution for potash, then in general use. Many of the bleachers, however, used it without paying him, and a combination was formed to resist the right of the patentee. In December 1802, an action for damages was brought against Messrs Slater and Varley, nominally the defendants, but who, in fact, were backed and supported by a combination of almost all the bleachers in Lancashire. In consequence of this action, the patent right was set aside by the verdict of a jury and the decision of Lord Ellenborough, who used very strong language against the patentee. The grounds of this decision were, that the patent included a mode of *ducking* with quicklime and water, which was not a new invention. It was decided that, because one part of the patent was not new, therefore the whole must be set aside. Lime was indeed used previous to the patent of Mr Tennant; but it was employed in a quite different manner from his, and he would have allowed the bleachers to continue their peculiar method without any objection, because it would have been productive of no injury to his emolument.

In consequence of this decision the use of liquid chloride of lime in bleaching was thrown open to all, and speedily came to be universally employed by the bleachers in Britain. Mr Tennant, thus deprived of the fruits of several years of anxious and laborious investigation, advanced a step farther, to what may be considered as the completion of the new method. This consisted in impregnating quicklime in a dry state with chlorine, an idea originally suggested by Mr Charles McIntosh of Cross-Basket, then a partner with Messrs Tennant and Knox. A patent for this was taken out on the 13th of April 1799, and he began his manufacture of solid chloride of lime at first upon a small scale, which has ever since been gradually extending, and the manufactory is now the largest of the kind in Great Britain.

The various processes for the preparation of the so-called chloride of lime, or bleaching-powder, as conducted at the present day, and its other applications in arts, will be found described under the head of CHLORINE.

#### BLEACHING OF COTTON.

Of the two great staples, cotton and linen, to the whitening of which the art of the bleacher is directed, cotton is the more easily and expeditiously bleached. The basis of all vegetable fibres is cellulose or ligneous tissue, a pure white substance, and it is to obtain this body in a state of purity, free from the resinous matter naturally associated with it as well as from adventitious impurities

imparted in the process of spinning and weaving, that is the object of bleaching. The operations, although apparently complex and numerous, are essentially simple, though frequently repeated, and the greatest variety of detail is connected with the finishing of cloth, which is in reality a separate industry, frequently conducted in distinct establishments under the name of calendering and finishing works. Bleaching proper resolves itself into washing with suitable detergents, and subjecting the washed material to the influence of chlorine, whereby the colouring matter either belonging to the fibre or imparted to it is oxidized and discharged.

The general arrangements of a bleach-house will be made plain from the ground-plan (fig. 1). The various pieces

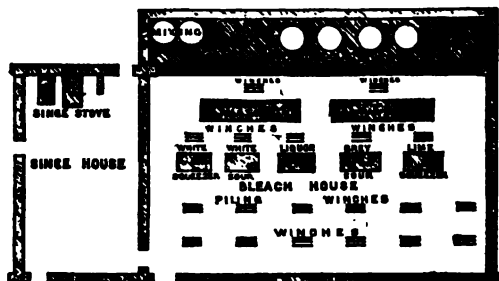

FIG. 1.—Ground-Plan of Bleach-House

of apparatus, the positions of which are there indicated, will be described in connection with the sequence of operations through which the cloth passes in the process of bleaching. In the best arranged works, it should be mentioned, where power is required to work any machine, it is generally supplied by a separate engine attached to the machine itself, instead of by gearing carried from one engine for all the machinery. For this plan, as well as for the greater portion of the illustrations which follow, we are indebted to Mr William Mather, of the eminent firm of Mather and Platt, Salford, to whom we are also under obligation for much valuable practical information. We have also to express our indebtedness to Mr Alexander Crum of Thornliebank, for the fullest access to the important works of his firm, and for the cordial assistance afforded by the managers of its various departments.

The sequence of operations in the bleaching and finishing of calico has undergone no change in its general details since the bleaching-powder process was first introduced; but the mechanical arrangements by which the operations are conducted have been the subject of frequent improvements. The ingenuity of engineers and bleachers has been chiefly directed towards the decreasing of manual labour, economy of fuel and materials, and the rapid completion of the various processes. The application of factory legislation to bleach-works by the Bleaching and Dyeing Works Act of 1860, by imposing a necessity for regular and stated hours of work, still further stimulated the production of apparatus and arrangements for prompt and certain completion of the various operations. Consequently a great part of the old machinery and arrangements of a bleach-house have now disappeared, and the processes are carried on in a continuous series of operations by machinery and appliances to a large extent self-acting. Formerly each piece of goods was separately treated and carried by hand or on barrows from one stage to the next; now the pieces are sewn end to end, as many as 1000 pieces, measuring perhaps 20 miles, being operated on in one stretch.

As various pieces of old machinery are yet in use for certain kinds of work, it has been considered desirable to

give descriptions and figures of some of them, and these, at the same time, will serve the further purpose of indicating the nature of the mechanical improvements which have been carried out, in recent years, in bleaching establishments. The important and frequently repeated operation of washing was formerly conducted either at the wash-stocks or washing-mill or in the dash-wheel. The wash-stocks, which are yet in use in many large works, especially where linen is the bleacher's staple, consists of a trough or box for holding the goods to be washed, through which a constant stream of water is passing. A pair or more of heavy hammer-headed wooden beams, hung by long shafts, and playing into the trough, are alternately tilted against the cloth, causing the water by their momentum to work through and squirt out of the mass. This process of washing is rather tedious, occupying on an average about half an hour, and requiring besides a great amount of manual labour. The dash-wheel (fig. 2) is a cylindrical box revolving on its axis. It has four divisions, as shown by the dotted lines, and an opening into each division. A number of pieces are put into each, abundance of water is admitted behind, and the knocking of the

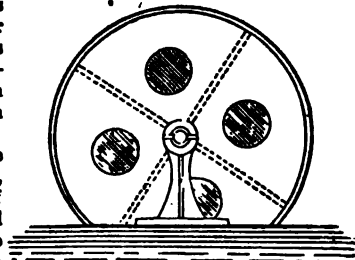

FIG. 2.—Section of a Dash-Wheel.

pieces as they alternately dash from one side of the division to the other during the revolution of the wheel effects the washing. The process lasts from four to six minutes. The dash-wheel is used to the present day in the bleaching of curtain materials and fine muslins. In nothing have greater improvements been effected than in the arrangement of the kiers or vessels in which the cloth is boiled or "bowed." An old form of kier is seen in fig. 3. It consisted of a cylindrical vessel AA, 9 feet wide, of wood or iron, having a false bottom BB, on which the goods were placed, about 6 inches from the real one. A small pipe E, in the centre of a wider one CC, conveyed the steam from the steam-boiler. When the liquid boiled at the bottom, where the steam issued, the steam forced its way up the pipe CC, carrying with it a quantity of the lye, which was thrown back by the small cover D, spreading itself over the surface of the goods, and filtering through them into the space below the false bottom, where it was again heated by the steam, reascending the pipe CC, and so on in constant succession, till the boiling was completed. FF is a wooden cover which prevented the cooling of the materials below a boiling heat.

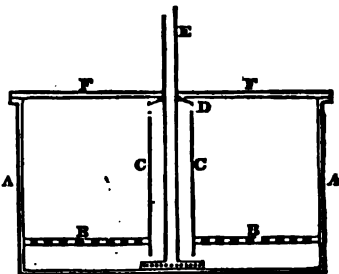

FIG. 3.—Section of Kier (old form).

The bleaching of common calico is divided into two branches—1st, print bleaching, in the case of which the goods are bleached as a preliminary to the process of calico printing; and 2d, white bleaching, which applies to goods to be finished white or unprinted. The processes differ in some of their details, as in white bleaching it is only neces-

nary to satisfy the eye, whereas in print-bleaching the material must be rendered chemically pure, otherwise the colours in the subsequent printing process would be dull and blotchy. The print bleaching must therefore be more thoroughly done than the other; but as the processes are generally the same, it will be sufficient to indicate the points of difference in the various stages through which the material in both cases passes. A process preliminary to bleaching is

*Singeing.*—Gray calico as received from the looms is generally in lengths of 37½ and 50 yards. A large number of these, sometimes as many as 1000, measuring more than 20 miles in length, are sewn into a continuous web. At the extremities of each owner's lengths, the name of the firm, or some distinguishing mark, is either stamped on in tar, or marked by means of coloured threads. These long lengths are then submitted to the operation of singeing, which has for its object the removal of the downy pile and short threads from the surface of the cloth, which would interfere with the appearance of finished white goods, and with the uniformity and sharpness of patterns in the case of prints. Several methods of accomplishing this have been employed, but that most commonly used is the system of plate singeing illustrated in fig. 4. A pair of

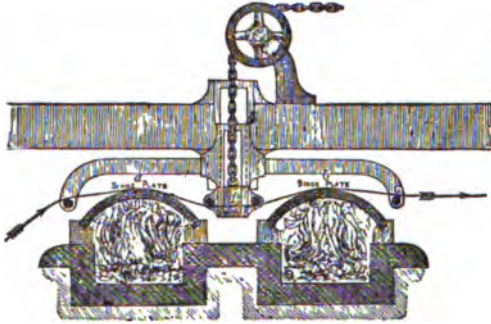

FIG. 4.—Section of Singe-Stove.

singe-plates, *a* and *b*, made of thick bent sheets of copper, are mounted over the flues of a fire sufficient to raise a white heat. The plate *b* is most highly heated, *a* being at the end of the flue furthest removed from the fire. The cloth enters over a rail *c*, and in passing over the plate *a* is thoroughly dried and prepared for the singeing it receives when it comes to the highly-heated plate *b*. A block *d*, carrying two rails in the space between the plates, can be raised or lowered at pleasure so as to increase or lessen the pressure of the cloth against the plates, or, if necessary, to lift it quite free of contact with them. The system of plate singeing is found generally sufficient in practice, but the caking of paste and dirt on the plates from the cloth as it passes over them, and variations in the heat of the plates, often lead to irregularities in singeing. A combination of plate and gas singeing is frequently employed to overcome the deficiencies of plate singeing alone. In this case the cloth is passed first over an ordinary plate, and then on to another, along the ridge of which is a long narrow slit, which allows the issue of a gas flame produced from coke burning immediately under it. By this means long loose threads are more effectually burned off than in plate singeing, and a more uniform heat is applied to the gray cloth. Fig. 5 is a sectional view of a very efficient singeing apparatus introduced by Messrs Mather and Platt. The figure represents the first half of the machine, the second portion being precisely similar in arrangement. The singeing in this case is accomplished by the burning of a

mixture of coal-gas and atmospheric air admitted by a pipe

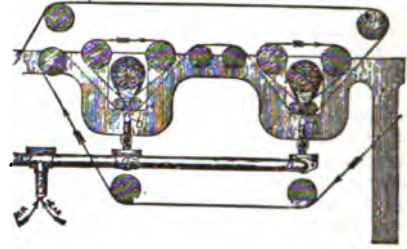

FIG. 5.—Gas Singeing Apparatus.

intense heat and a blue smokeless flame. The cloth is carried by a series of rollers to the gas jets, and in passing over the rollers *c, c, c* the one side of the cloth impinges laterally four times against the flame, which is never permitted to pass through the fabric, but only shaves its surface. The back is thus singed in the first portion of the apparatus, and being turned over on roller *d* it is carried forward to another pair of jets, where, being thoroughly dry, the face side of the cloth is completely singed by going over exactly the same course through which the back is carried in the first part. By an arrangement not shown in the illustration, the attendant of the machine can instantaneously lower the gas burners by a treadle movement in case of any stoppage or accident, and thus prevent the cloth from being burned. With a proper pressure of gas this machine singes at the rate of 60 yards per minute.

At this stage the cloth has now in addition to the brown coloured incrusting substance and the resinous material proper to the fibre, a dark-coloured carbonised surface, caused by the singeing process, the weaver's paste or dressing, tallow or other fat introduced in the process of weaving, and the accumulation of dirt which the handling of weavers and others may have produced. The object of the subsequent processes is to wash out the mechanical impurities and resinous substances from the cloth, to render soluble by chemical agencies such as are otherwise insoluble in water, and to oxidize the colouring matter of the cotton by the chloride of lime as already explained.

*Liming.*—In some cases it is the practice immediately after singeing to steep the pieces in water and pile them up wet for a night, in order to loosen and partly ferment the weaver's paste, which is then in large part removed by washing in a machine to be subsequently described. The "gray-backs" which have been used in calico-printing have always to be thus steeped, and at one time it was the practice to leave the cloth so long in this steep that it acquired a most offensive odour. This preliminary steeping and washing facilitates the percolation of the liquor through the fabric in the process of boiling, but notwithstanding this advantage it is generally dispensed with, and the goods pass direct from the singeing to the liming process. The pieces are formed into a loose coil or rope by being passed through circular rings of glass or pottery called "pot-eyes," and worked up and down several times in a strong milk of lime, in order that the whole may be uniformly and thoroughly impregnated. The arrangement for liming will be understood from fig. 6, which is a sectional view of a "squeezer," an apparatus used repeatedly in subsequent operations as well as in this of liming. The cloth passes up and down as indicated by the arrows, dipping several times into the solution, and before passing finally on to the kiers for boiling it is slightly "nipped" between the



is then let into the kier A, through the tap G, until the necessary quantity has been supplied, about 20 gallons of caustic soda at 70° Tw., and 400 lb lime for the full charge being used. The steam is then turned on slowly, and by its pressure the liquor in kier A is made to pass with great force through the cloth, and then up the pipe D, through the 3-way valve, into the kier A'. When all the liquor has passed over, the steam valve E' is reversed, steam is shut off from A, communication is opened to pipe D', and valve E' turned so as to admit steam to A', when the action of forcing the liquor through the cloth up the pipe E' into kier A is performed. This alternate passing of the liquor backwards and forwards, see-saw fashion, through the cloth, constitutes the operation of boiling. The steam also has great effect if left in contact with the cloth for a few minutes in one kier, after the liquor has gone over to the other kier. This process is continued for eight hours (nearly one-third the time formerly required in what are termed low-pressure kiers), with steam of from 30 to 50 lb, during which time the liquor passes about 16 times from one kier to the other; then the valves HH' are opened, and all the liquor expelled by the steam from the cloth into a drain. The steam is then shut off, the man-hole lids removed, and the ends of the two chains of cloth taken out and passed through pot eyes, which guide the pieces to the washing-machine.<sup>1</sup>

**Washing.**—The cloth as it issues from the kiers is found to have assumed a very dirty brown aspect. Formerly, the apparatus used for washing was either the wash-stocks or the dash-wheel, to which allusion has already been made. The machine now generally employed is represented in section in fig. 9. It consists of a pair of wooden bowls

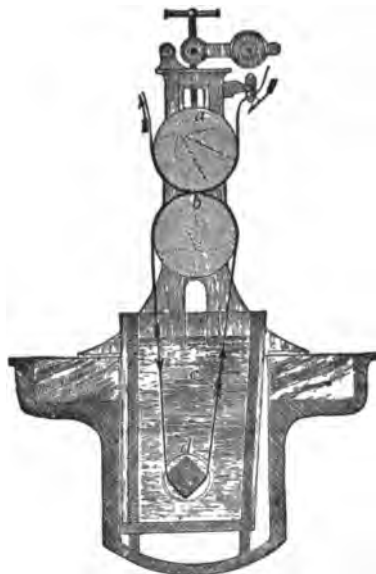

FIG. 9.—Section of Washing-Machine.

or cylinders *a* and *b*, about 9 feet long, mounted in a strong framework, and arranged to press against each other in their revolution. Plane tree is the wood most suitable for making these bowls. Running underneath the whole length of the bowls is a box or trough *c* filled with water, near the bottom of which a rectangular roller *d* is fixed. The water in the box is constantly renewed during washing operations by a current flowing in at the middle and escaping at each end. Two chains of cloth are washed in this machine at the same time, one being introduced at each extremity of the roller. The cloth passes down into the water under the roller *d* and up to the wooden bowls, between which it is caught and nipped, and down again

into the water, working its way in a spiral manner from the end to the centre of the machine, passing nine times through the water end between the bowls in its progress. Its course inwards is guided by a strong wooden rail, from which pegs project, arranged according to the number of turns to be given to the cloth. In the centre part of the upper bowl there is a lapping of cotton rope, which projects a little above the surface of the wood, and serves to give the cloth, as it finally issues from the machine, a much stronger squeeze than it would obtain between the long even bowls, and thereby expels a large proportion of moisture. As the cloth travels inwards towards the centre of the trough, while the flow of water is outward to escape at each end, the cloth on each revolution is meeting water more nearly pure, till just at the point where it issues from the trough for the last time, the clean water entering the trough is powerfully spurted upon it, thus giving it a thorough rinse before it is finally squeezed. It is usual to pass the cloth from the lime boil either through a pair of such washing-machines, or twice through the same, in order to expel the last trace of calcareous soap and uncombined lime from the texture.

In addition to this machine various other devices have from time to time been proposed and introduced to perform the important operations of washing. Among these the continuous washer of Mr Henry Bridson of Bolton-le-Moors, Lancashire, patented in 1852, is deserving of notice as a simple and efficient washing machine. Mr Bridson's washer consists of an oblong tank or trough of cast-iron which, in use, is kept about half filled with water. Within this tank, just dipping into the water, two cross shafts are fixed, which are geared to revolve in the same direction by spur-gearing mounted outside the trough. Each shaft carries a pair of discs of large diameter, and between the discs of the two shafts a pair of bars placed diametrically opposite each other are mounted. These bars form flat winces or revolving frames, by the revolution of which the fabric is not only carried forward, but is in its progress caused to strike with great violence against the surface of the water. The intermittent flapping and shaking motion thus communicated to the material has a powerful effect in detaching adhering impurities from the cloth. Another form of washing-machine in use in Lancashire consists of a row of eight vats or troughs arranged in an ascending series, so that the overflow of water from the highest or last runs into the second highest, and so downwards till it escapes from the lowest or first. The cloth enters at the lowest trough, and is carried by guide-rollers up and down through the entire series, issuing at the top between a pair of squeezing rollers.

**Gray Sour.**—From the washing-machine the chain of cloth is passed through a pair of squeezers, by which a large proportion of moisture is expelled. The operation of souring, which comes next, is performed in an apparatus of the same construction as the washing-machine, the trough under which contains the souring liquor. For white bleaching a solution of hydrochloric acid of a strength of 3° Twaddle (sp. gr. 1.010) is used, and for print bleaching the solution is made up to 4° Tw. Through this the cloth is passed up and down twice by the revolution of the bowls, and piled up in the sour in stillages for some hours. The object of the souring is to dissolve any traces of free lime which may have been left in the washing, and to decompose the calcareous soap.

**Second Boil.**—After having lain in the sour for a sufficient length of time the cloth is passed through squeezers to expel as much as possible of the acid, and again washed in the machine. It is next passed into a kier or set of kiers, precisely as after liming, for the second boil, which in the

<sup>1</sup> For this description of the Barlow kiers we are indebted to Mr William Mather

case of print bleaching is done with a solution of soda-ash and rosin. For a pair of Barlow kiers boiling 12,000 lb of cloth, the quantities used are 350 lb of soda-ash and 200 lb of rosin dissolved with 30 gallons of caustic soda at 70° Tw. The boiling is carried on for ten hours, in a like manner and at the same pressure as in the case of the lime boiling. The soda-ash and rosin form a soap, which dissolves out the free fatty acid in the cloth, and acts on the calcareous soap remaining by forming carbonate of lime and a soluble soda soap. In the white bleaching of 2700 lb of cloth, the boiling solution is 8 gallons of caustic soda at 70° Tw., but by some bleachers soda-ash is employed in the proportion of 80 lb to 2700 lb of cloth. From this boil the cloth is passed on to the washing-machine, and then squeezed, when it is ready for "chemicking" with the bleaching-powder solution.

**Chemicking.**—When the previous processes have been efficiently carried out, the cloth will, at this point, have attained a considerable appearance of whiteness and purity. The "chemicking" or liquoring with bleaching-powder which it now undergoes is conducted in a similar manner to the souring already described. The chemick is used as weak as possible, the solution varying from  $\frac{1}{2}$ ° to  $\frac{1}{4}$ ° Tw. (sp. gr. 1.000625 to 1.00125) according to the weight and condition of the cloth under treatment. It is run through this liquor, gently squeezed, and piled up for four or six hours. It is then squeezed and washed; and at this stage the bleacher has to judge whether the cloth requires to be chemicked a second time, which, in the case of heavy goods, is frequently necessary. If a repetition of the process is required, the cloth is again passed into the kiers, boiled with a solution of soda-ash, and the other processes repeated as before.

**White Sour.**—After lying in the chemick the goods are again washed and squeezed, and afterwards soured in machine with sulphuric acid, used at a strength of about 4° Tw. (sp. gr. 1.020), and piled up for a period of at least three hours. Thereafter, in order thoroughly to expel all acid the goods are twice washed, and finally squeezed, which concludes the operation of bleaching proper. The calico should now present a snow-white aspect, and should be fit to take the most delicate shades of colour when it is to be used for printing purposes.

**Opening.**—In passing through the numerous processes detailed in the foregoing statement, the cloth has been always in the form of a coil or loose rope. In the drawing from one machine to another it has been also pulled somewhat to the length at the expense of breadth, and in places it is likely to have become a little twisted. The pieces have therefore now to be opened out to their full width, and, if necessary, evened. The opening out is effected by passing the pieces to a winch placed at a considerable height when the weight of the cloth itself in passing upwards unfolds it, and the selvages are caught and extended by a boy just before it passes on to the winch. When necessary it is caught beyond the winch by an opening-machine, such as that patented in 1871 by Mr Wm. Birch of Salford. It is a complex apparatus, working by endless bands, on which are toothed projections, and these, travelling from the centre to the sides in opposite directions, open and spread out the cloth before it passes over the roller which is mounted on the machine. From the opener the cloth passes at once to the drying-machine (hereafter described), after passing over which cloth intended for printing is folded or batched on rollers, and its further treatment belongs to the art of calico-printing.

**Finishing.**—So far as regards bleaching proper the process is now at an end, and the further operations which white calicoes undergo have only for their object the improvement of their appearance for the market. But

although the finishing adds in no way to the quality of the material, it is regarded as of great value by the merchants, and the finish of a bleacher is of more importance than his bleaching. A great variety of finishing operations have to be employed, according to the different qualities of textiles, and the purposes to which they are devoted. Finishes are "beetled," "calendered" (either "stiff," "medium," or "soft," or "glazed,") and, for dress muslins, &c., "elastic." As the processes and appliances for these finishing operations are very numerous and varied, they cannot here be described in detail. In most cases they are the same as used in the finishing of calico prints, and more information will be found under that head. We shall here confine our remarks chiefly to the finishing of ordinary white beetled calicoes.

**Water Mangle.**—The cloth, when brought into the finishing-room, is passed over a stretching rail into a trough of boiling water and between a series of calender rollers, in which it is powerfully pressed. A common arrangement of the cylinders of the water mangle is to have a series of four, two of small diameter being made of copper, and two larger of condensed cotton; but wooden bowls are also sometimes employed with only a single intermediate copper cylinder. By this mangling process the water is equalized throughout the whole piece, the threads are flattened, and the cloth stretched, smoothed, and wound upon a roller, and thus rendered fit for receiving the starch.

**Starching.**—It is in this stage that so much is done by some bleachers to give cloth a factitious appearance of weight and bulk by filling up the interstices between the fibres with compounds which have no other object than to please or deceive the eye, and some of which have a decidedly deleterious influence on the tissue they are intended to improve in appearance. A great variety of mixtures, both cheap and nasty, are used by some finishers in place of starch with a view to produce weight and appearance, but, naturally, as little information as possible on this point is permitted to leak out to the public. What ought to be, and by reputable bleachers really is, used is pure starch, either of Indian corn or wheat, or both, made up into a stiff mucilage and blued with ultramarine or indigo. The cloth passes over a stretching rail into a trough of this starch, in which a roller is mounted. As it comes out of the starch it is caught between a pair of bowls, by which the superfluous starch is squeezed out and thrown back into the trough, the cloth passing on to the drying-machine. The starching mangle and drying-machine are seen together in fig. 10.

**Drying.**—The drying-machine (fig. 10), consists of a

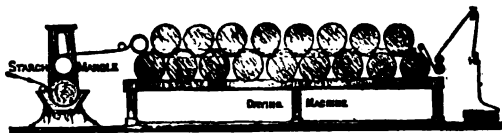

FIG. 10.—Starching Mangle and Drying Cans.

number of cylinders made of tinned iron or copper, and filled with steam of low pressure. The cloth passes alternately back and face over one and the other, and emerges to be placed down at the end perfectly dry. This system of drying was introduced among the first mechanical appliances used in calico-printing, and has not as yet been superseded by any other plan. Various improvements in detail, we learn from Mr William Mather, as to the construction of the cylinders and the mode of applying steam to them have been recently introduced, but the machine remains the same.—One important defect has been recently

removed by an alteration in the construction of the cylinders, to prevent collapse, in case a vacuum were formed by the rapid condensation of the steam. A spiral rib or stay is made to run from end to end of the body of the cylinder, giving support uniformly the whole length, and serving at the same time as a screw to drive the condensed water, as the cylinder revolves, to one end, where it is ejected through a nozzle. The steam enters at a nozzle, from the framing which is cast hollow, and serves as a pipe to distribute the steam to all the cylinders in the machine, while the framing on the other side serves in like manner to receive and discharge the water.

*Damping.*—From the drying cans the cloth is passed on to the damping-machine, where it is uniformly moistened by an exceedingly fine spray of water thrown upon it. The spray is thrown up by a circular brush, the tips of which are allowed to dip into water in a trough over which it revolves. Mather and Platt have introduced a manifest improvement on this plan by throwing the water in fine jets on the brush from a pipe which runs parallel with it. By this means the quantity of water and degree of moisture can be regulated with the utmost nicety. Fig. 11 shows the damping-machine in section as modified by

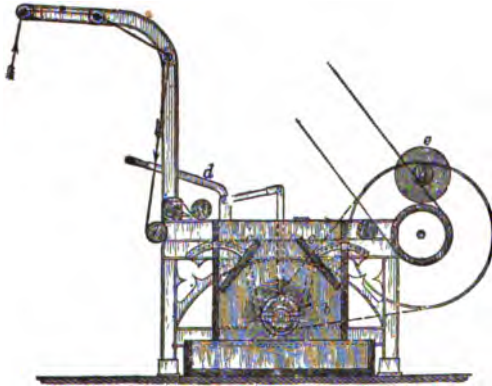

FIG. 11.—Damping-Machine.

Mather and Platt. *a* represents the circular brush revolving in a trough, and *b* is the pipe from which the water is squirted on the brush. The spray from the brush is confined by two sloping boards *c, c*, which work on quadrants, and the lever *d* raises or depresses the brush at

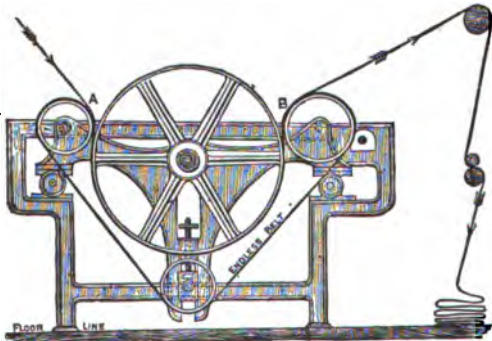

FIG. 12.—Elevation of Belt-Stretching Machine.

pleasure. The course of the cloth over the machine is indicated by arrows, and after damping it is batched on

an iron or wooden beam *e*, when it is ready for the process of beetling. When goods are to be finished of any particular width, they are at this stage broadened by such an apparatus as the belt-stretching machine of Mather and Platt shown in elevation in fig. 12 and in plan in fig. 13. In

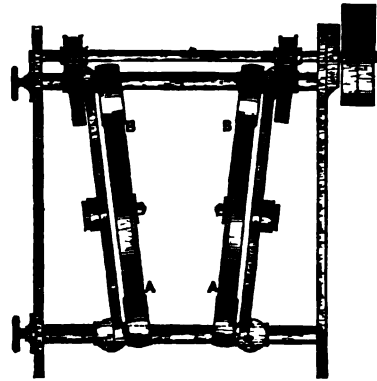

FIG. 13.—Plan of Belt-Stretching Machine.

this machine the full width of the cloth is obtained by the selvages being held firmly by a belt and pulley on each side, the pulleys revolving at such an angle that the stretch on the cloth has to compensate for the difference in distance between these pulleys at *A* and *B*.

*Beetling.*—The beetles ordinarily employed are a series of long heavy wooden piles arranged in a frame. These piles are alternately raised and allowed to fall with their full weight against the beamed cloth by the revolution of a roller having a spiral series of notches, which catch a corresponding range of projections on the piles. The beam with the cloth is made to revolve gently by a ratchet motion as it is submitted to this hammering, which goes on for two or three hours. Recently Mr John Patterson of Belfast has patented and introduced a form of beetling-machine (fig. 14), which from its highly effective action,

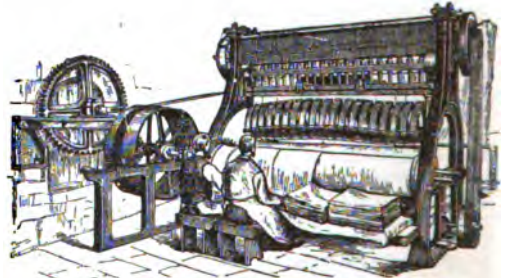

FIG. 14.—Patterson's Patent Beetle.

is likely to come into very extensive use. The advantages claimed for his machine over the common beetle Mr Patterson thus states: "Heretofore, the beetling of textiles fabrics has been done by means of beetles, or stampers, falling upon the fabric by the action of gravitation, each stamper or beetle falling 55 or 60 times per minute through a space of 13 to 15 inches. This rate of speed cannot be accelerated by gravitation, and the consequence has been that in order to increase the quantity of work done by the ordinary beetles, very bulky and massive machinery has been employed, requiring large and expensive buildings and driving gear. The new beetling-machine requires not one-tenth of the space, very much lighter gearing, and



instead of making 60 blows per minute, each beetle makes from 420 to 500 blows per minute. The blows are not by the action of gravitation, but are actuated by a series of cranks cut upon a solid steel shaft. There are connecting rods from the steel cranks to semicircular springs. The beetles are attached to, or suspended between, the points of the semicircular springs by means of leather straps. When the crank shaft is set in motion the beetles are snatched up in regular sequence by the upward motion of the cranks, and the springs are compressed by the weight of the beetles, as in fig. 15, and by the combined upward motion of the cranks and the springs the beetle is thrown upwards with great impetus. The upward motion is stopped as the cranks pass the top centre, and the beetles are thus met by the springs and thrown violently into them, causing them to be again compressed, as in fig. 16.

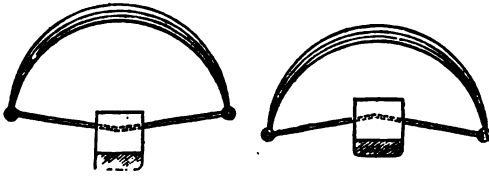

FIG. 15. FIG. 16.  
Hammers of Patterson's Beetles.

When by the downward motion of the cranks the springs are allowed to throw the beetles on the cloth beam, a rapid forcible whipping blow is imparted to the cloth, which does not cut or injure it in the manner often done by the slow dropping blows of the ordinary beetles. The weight of the blows can be instantly varied by varying the speed of the crank shaft, from the slightest touch to the heaviest penetrating blow. It is found that twice or thrice the number of folds of cloth can be beetled effectively on the cloth beams more than can be done on ordinary beetles, that is, instead of 200 folds on the beam, 400 or 600 folds can be equally well beetled on the new machine."

**Calendering.**—When it is desired to finish cloth with a stiff or with a glazed finish, instead of being submitted to the operation of beetling, it is finished in the calender. The calender, as its name *καλιφόρος* implies, is a series of cylinders mounted above each other in a strong framework. The number of cylinders and the material of which they are constructed vary. In some only three cylinders or bowls are employed, and in others they are four or five. One or two of the bowls are made of metal, and two or three are either of wood, of condensed cotton, or of paper, and they must always be turned with great accuracy and be free from all warping. Cylinders of paper or condensed cotton have a very smooth surface and a considerable amount of elasticity. Between these cylinders the cloth as it comes from the damping-machine is passed, and twice, thrice, or four times, according to the construction of the calender, it is powerfully pressed. The pressure gives the cloth a very even surface, condensing the fibres, and produces a shining lustre. When the cloth is submitted to friction, as well as to pressure in a heated calender, a glazed finish is produced. The frictional effect is produced by the cylinders being geared to move at different rates of rapidity, so that in their revolution they rub over the surfaces of each other in addition to communicating pressure. Fig. 17 shows a finishing or friction calender in section. The metal cylinder *a* is made hollow so that it may be heated by the introduction of steam or gas, *b* and *d* are of compressed cotton or paper of the same diameter as *a*, and *c* is a smaller metal cylinder. The pressure of the cylinders is regulated by means of the screw *e*, and the compound lever *f*, which is adjusted by the double screw on the con-

necting rod at *g*. The cloth enters over stretching rails and rollers, passes through the calender in the manner indicated by the arrows, and is batched on roller *A*.

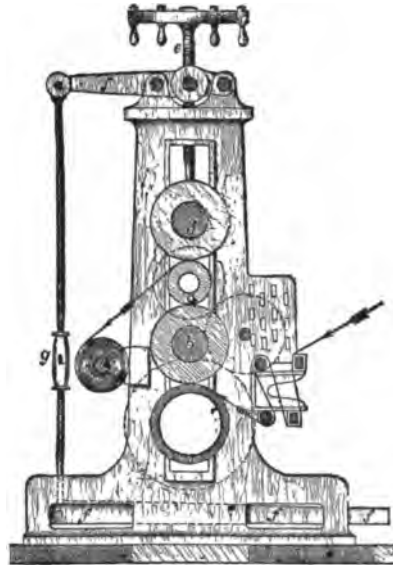

FIG. 17.—Section of Calender.

**Elastic Finish.**—This particular kind of finish is applied to muslins and similar thin fabrics, and has to be done in highly-heated apartments called stentering stoves. Formerly the work was entirely done by manual labour, and consisted in holding the fabric by the selvages, and pulling it forward and backward while it was drying in the heated air. In this way the threads were made to rub against each other, and the cloth was thus deprived of the hard, stiff board-like appearance it would have possessed if left motionless when drying. Mr Ridgway Bridson was the first who introduced a machine which successfully supplanted hand labour in producing the elastic finish in muslins. His stentering frame is thus described:—Two horizontal rails or frames extend side by side the whole length of the machine, carrying at each end a large wheel or pulley, with small pins fixed at equal distances in its periphery. These pins pass through corresponding holes in an endless band which passes round the pulleys. On the surface of the endless bands are fastened very fine needle or tenter points to hold the selvages of the fabric as it passes through the machine. The horizontal rails can be moved away from each other laterally, so as to stretch the fabric breadthwise. The rails are of equal length with the fabric to be treated, which is fastened by the selvages at one end to the centre pins, and the pulleys being set in motion, the entire piece is carried on and stretched out over the machine, and the rails are then moved outwards to broaden the fabric. The elastic finish is given by communicating alternate vibrating motions to the two rails, by which a diagonal stretching is given to the muslin while in the process of drying.

At the conclusion of any of these various finishing processes, the goods are folded either in a plaiting-machine or by girls hooking plaits of definite length by the selvages on steel spikes. The end of each separate piece is then stamped with some device or motto intended to serve as a trade-mark. After the goods have been regularly folded, they are placed piece by piece, separated by sheets of

pasteboard, in a Bramah press, and after a certain interval an iron plate is substituted for the pasteboard, to prevent any inequality in the pile. Finally, the folded pieces are prepared for the market by fastening a band of gilt and ornamented paper around each end, which with the imprinted device is in some way regarded as a guarantee of good quality.

The whole operations of bleaching and finishing occupy on an average eight days, although goods can be hurried through much quicker if occasion arises. The cost, which of course will vary with the price of fuel and other circumstances, is very small as compared with the value of the material, and does not on an average, for shirting calicoes and the like, exceed 1½d. per lb weight of cloth.

#### BLEACHING OF THREAD.

We have been favoured by Messrs J. and P. Coats of Paisley with the following outline of the processes in the bleaching of thread:—

1. The various Nos. of thread are prepared before boiling.
2. The first boil. The kier used is a common vomiter, into which are put water and a solution of caustic lye,—the proportions being regulated by the number of pounds of thread to be treated.
3. The first bleach. The thread is placed in a box, and a sieve let down upon it. Underneath the box is a well which is filled with water and chlorine. The liquor is drawn up by a pump, and thrown upon the sieve, through which it passes, and filters through the thread into the well.
4. The thread is next moved into a souring-box, also covered with a sieve, where it is washed to take out the chlorine of the previous process.
5. A souring-well under the souring-box is now filled with water and sulphuric acid, and this mixture, called the *sour*, is pumped up on the sieve over the souring-box, through which it runs back into the souring-well, in the same manner as described in process No 3.
6. Before removing the thread from the souring-box it is washed with water through the sieve.
7. It is next washed in a washing-machine.
8. The scald, or second boil in kier. Various mixtures are used for it. Some prefer black soap and crystals of soda; others use caustic lye.
- 9-13. Repetition of Nos. 3, 4, 5, 6, and 7.
14. The thread is now extracted, *i.e.*, dried in hydro-extractor.
15. Stocking. The stocks are boxes about 3 ft. long, by 2 ft. wide, and 2 ft. deep, with a large woollen mallet hung in each, similar to those used in bleaching linen. The thread bunks having been properly prepared, so that they will not get loose, are put into the stocks with a mixture of hot soap and water, and beat there till of the proper colour. It is then taken out, and
16. Washed in washing-machines, and
17. Extracted.
18. The bluing process is done in a box filled with a solution of water and extract of indigo. As much thread is put in as the box will contain. It is let stand for a time, after which it is taken out and thrown on a barrow.
19. It is next taken to extractor and dried, and
20. Placed in the stove. After being a sufficient time there it is
21. Removed to cooling shed, where it is hung up to cool.
22. It is now taken to stretching-machine, where it is passed over hot rollers to take out the curl and moisture received in cooling shed.
23. Taken to warehouse, where Nos. are classed and made up in bundles.

#### BLEACHING OF LINEN.

The bleaching of linen is a much more tedious and difficult operation than the bleaching of cotton. The process of water-retting, or rotting, by which the fibre is separated from the woody portion of the stalk, lodges a large proportion of colouring matter in the fibre, with which it enters into very intimate combination. The amount of colouring matter which has thus to be dealt with in the bleaching of linen is very great, being as much as one-third of the entire weight of the fibre. In the early part of the century a great amount of public attention was given to a plan proposed by Mr James Lee for preparing flax fibre without the process of steeping or retting, by

which it was affirmed that, among other advantages, it would only be necessary simply to wash, in soap, linen fabrics made from fibre so prepared, to render them pure and white. Mr Lee obtained a special Act of parliament allowing the specification of his patent to remain sealed for seven years, and his plans were entered into in a most full and laborious manner by the Irish Linen Board. After the expenditure of many thousands of pounds on his machines and experiments, the plan had to be entirely abandoned as a failure. More recently, Chevalier Claassen renewed the attempt to prepare flax without steeping, by breaking it by means of machinery, separating the refuse part of the stalk from it, and then by a chemical process splitting the hollow fibres, so as to reduce them to a soft cottony state fit for spinning by means of the cotton-spinning machinery. The fibre was proposed to be split by steeping the prepared flax in a solution of carbonate of soda, and then plunging it into dilute sulphuric acid. The sudden evolution of carbonic acid gas within the hollow tube of the flax was said to have the effect of splitting up the fibre and reducing it to fine flat threads possessing the felting properties of cotton. Sir Robert Kane, in his Report to the House of Commons, May 20, 1852, states that the whole process failed. The machinery for the beating and cleansing of the flax failed to separate it sufficiently from the refuse part of the stalk; and the chemical process for the splitting of the hollow tube only broke up small portions of the exposed ends, leaving the greater portion untouched. Various other plans of preparing flax fibres without water or dew-retting have from time to time been proposed and patented, but hitherto none of them has stood the test of extended practical operation. Till towards the end of last century the bleaching of linen both in the north of Ireland and Scotland was accomplished by bowking in cow's dung and souring with sour milk. In the year 1764 Dr James Ferguson of Belfast received a premium of £300 from the Irish Linen Board for the application of lime in the bleaching of linen. Notwithstanding this reward the use of lime in the bleaching of linen was for a long time afterwards forbidden in Ireland under statutory penalties, and so late as 1815 "Mr James Barklia, a respectable linen-bloomer of Linen Vale, near Keady, was prosecuted for using lime in the whitening of linens in his bleach-yard." The bleaching of linen to the present day is conducted much more in the primitive fashion of last century than is the practice with cotton-bleaching. Owing to the stiffness and inelasticity of flax fibres, a great part of the machinery used for cotton is not available for linen, and solutions of acid and bleaching-powder require to be used in a very dilute condition for linen fabrics, involving frequent repetitions of the various processes before a satisfactory white is produced. "Crofting," or exposure to the air on grass, is also very largely resorted to in the bleaching of linens, especially for plain shirting and sheeting, which necessitates the possession of very extensive grass parks in connection with works, and renders the process both tedious and subject to the influences of the weather. A large proportion of linen cloth is half-bleached or improved in the yarn before being woven, and it consequently requires less bleaching than that which comes in its original "green" condition. The following is an outline of the two chief methods, with and without crofting, as pursued in the principal Scotch linen bleachfields at the present day:—

#### I. WITHOUT CROFTING.

- |   |   |
|---|---|
| 1. Linned.                                | 4. Soured with hydrochloric acid, and piled in sour for some hours. |
| 2. Boiled in open kier for about 6 hours. | 5. Washed at stocks.  |
| 3. Washed at washing-mill or stocks       |   |

- |   |  |
|---|--|
| 6. Boiled in soda-ash for 8 or 10 hours.        | 10. Boiled in alkali for 6 or 7 hours. |
| 7. Again boiled.                                | 11. Liquefied in chlorine solution.    |
| 8. Liquefied in chlorine solution and piled up. | 12. Washed.                            |
| 9. Washed.                                      | 13. Soured with sulphuric acid.        |
|   | 14. Washed.                            |

When necessary the processes from 10 to 14 are repeated. The whole processes occupy, on an average, four weeks.

11. WITH CROFTING.

- |                                  |  |
|----------------------------------|--|
| 1. Boiled in lime.               | 10. Liquefied.   |
| 2. Washed.                       | 11. Washed.  |
| 3. Soured.                       | 12. Soured with sulphuric acid.                          |
| 4. Washed.                       | 13. Washed.  |
| 5. Boiled in alkali and washed.  | 14. Boiled in alkali.                                    |
| 6. Exposed on grass 3 or 4 days. | 15. Liquefied.   |
| 7. Boiled in alkali.             | 16. Washed.  |
| 8. Washed.                       | 17. Soured with sulphuric acid.                          |
| 9. Exposed on grass.             | 18. Washed, and processes 14 to 18 repeated if required. |

With exposure on the grass the bleaching of plain linens usually occupies from 4 to 6 weeks. The finishing processes are essentially the same as in the case of calicoes. The following are the stages in finishing linen damasks:—

- |  |  |
|--|--|
| 1. Nipped in squeezers.                          | 7. Calendered.                             |
| 2. Blued in ultramarine in blueing-water mangle. | 8. Dried on steam cans.                    |
| 3. Starched in starching-mangle.                 | 9. Again calendered.                       |
| 4. Dried on steam cans.                          | 10. Viewed to detect rust spots and holes. |
| 5. Damped with fine spray.                       | 11. Lapped.                                |
| 6. Beetled.                                      | 12. Pressed in hydraulic-press.            |

Charles Tennant of St Rollox made some experiments in 1831 to determine by which parts of the process the chief loss was sustained during bleaching. The result was that in 1000 parts by weight, linen yarn lost—

- |  |        |
|--|--------|
| In the now abandoned fermenting alkaline steep 57 parts. |        |
| In 4 boils with caustic soda.....                        | 70 ..  |
| In 4 steeps with chloride of lime. ....                  | 170 .. |
| In 4 steeps in the sour .....                            | 18 ..  |

Total..... 315 parts in 1000.

BLEACHING OF PAPER-MAKING MATERIALS.

In addition to cotton and linen rags, esparto or Spanish grass (*Macrochloa tenacissima*) is now very largely used for the manufacture of the better classes of paper. Wood, especially the wood of the aspen (*Populus tremula*), is also now applied as a paper-making material. Jute has been used for printing paper, and straw is very largely employed, but chiefly for brown and packing papers. These and the numerous other substances used for paper-making are all reduced to the condition of "half-stuff" before they come to undergo the operation of bleaching, and the treatment they receive in this stage varies only in the amount of whitening required, and consequently in the proportions of bleaching solution used. It is therefore unnecessary to notice more than the process followed in the bleaching of the "half-stuff," which in Great Britain is very frequently prepared from a mixture of esparto fibre and rags. The bleaching solution of chloride of lime is either prepared in specially constructed cisterns, fitted with revolving agitators and stored in a reservoir for use, or prepared for immediate use in a wooden vessel. When the solution is made up to the requisite strength, and all insoluble sediment has sunk to the bottom of the vessel, it is ready for pouring into the engine. From 4 to 10 lb of ordinary bleaching-powder are used for every 100 lb of rag half-stuff, but a much larger proportion is required for esparto. Sulphuric acid in not more than a proportion of 1 lb to 4 lb of bleaching-powder is thereafter added in a highly dilute condition, and the whole, after mixing in the engine, is turned into the drainer, which is a large tank provided with a false bottom of perforated wood covered with wire-netting or bagging. In some cases the bleaching-liquids are not added to the pulp material till it is deposited in the drainer; and the acid

solution may be poured in first, or both solutions may be alternately used in small quantities. The bleaching process is sometimes carried on in separate engines constructed of materials not affected by the corrosive action of acid substances. Drained half-stuff may also be bleached in a suitable apparatus by the direct application of chlorine gas.

It is of the greatest importance to free the pulpy material from the last traces of chlorine before it is made into paper, as it would react upon the manufactured product and render it brittle. To eliminate the free chlorine and acid, &c., the pulp is washed in the beater with pure water till it ceases to redden litmus paper, or give other characteristic indications of the presence of such compounds. The prejudicial effects of chlorine and its combinations are also overcome by the addition of "antichlor," the hyposulphite of soda or of lime, which forms with them compounds that do not affect the colour of the paper, although it is desirable, as far as possible, to remove such compounds also by washing with water.

BLEACHING OF STRAW.

The fine wheat-straw used in Tuscany and elsewhere for straw-plaiting, after being cut, dried, and tied up in bundles, is stacked for a month. It is then spread out in a meadow, and exposed to the action of the sun and air, being frequently turned during that period. The lower joint of the straw is then separated leaving only the upper joint with the ear attached,—this being the only part of the straw used. It is then steamed, and after that exposed to the action of sulphurous acid gas prepared by burning sulphur, which complete the bleaching. It is then tied up in bundles, in which state it is ready for the market. In the strawplait-making centres of Great Britain—Luton, Dunstable, &c., in Bedfordshire—straw is bleached, chiefly after plaiting, by the influence of sulphurous acid gas.

WHITENING AND CLEANING PRINTS, MAPS, BOOKS, AND OTHER ARTICLES OF PAPER.

Chlorine was first applied to this purpose by Chaptal, and his method was employed with the greatest success by Vialard and Heudier, who by Chaptal's process restored several of the most valuable books of the French National Library. Chaptal's *modus operandi* is thus described in his own words:—

"They begin by unsewing the book and separating it into leaves, which they place in cases formed in a leaden tub, with very thin slips of wood or glass, so that the leaves, when laid flat, are separated from each other by intervals scarcely sensible. The acid is then poured in, making it fall on the sides of the tub, in order that the leaves may not be deranged by its motion. When the workman judges, by the whiteness of the paper, that it has been sufficiently acted upon by the acid, it is drawn off by a cock at the bottom of the tub, and its place is supplied by clear fresh water, which weakens and carries off the remains of the acid, as well as its strong smell. The leaves are then to be dried, and, after being pressed, may be again bound up.

"The leaves may be placed also vertically in the tub; and this position seems to possess some advantage, as they will then be less liable to be torn. With this view I constructed a wooden frame, which I adjusted to the proper height, according to the size of the leaves which I wished to whiten. This frame supported very thin slips of wood, leaving only the space of half a line between them. I placed two leaves in each of these intervals, and kept them fixed in their place by two small wooden wedges, which I pushed in between the slips. When the paper was whitened, I lifted up the frame with the leaves, and plunged them into cold water, to remove the remains of the acid, as well as the smell. This process I prefer to the other.

"By this operation books are not only cleaned, but the paper acquires a degree of whiteness superior to what it possessed when first made. The use of this acid is attended also with the valuable advantage of destroying ink spots. This liquor has no action upon spots of oil, or animal grease; but it has been long known that a weak solution of potash will effectually remove stains of that kind.

"When I had to repair prints so torn that they exhibited only scraps parted upon other paper, I was afraid of losing these fragments in the liquid, because the paste became dissolved. In such cases I enclosed the prints in a cylindrical glass vessel, which I inverted on the water in which I had put the mixture proper for extracting the oxygenated muriatic acid gas. This vapour, by filling the whole inside of the jar, acted upon the print, extracted the grease as well as ink spots, and the fragments remained pasted to the paper."

A solution of peroxide of hydrogen ( $H_2O_2$ ) has been used with great success in the restoration of valuable prints, as well as for cleaning and reviving oil painting darkened by the action of sulphurous vapours.

#### BLEACHING OF WOOL.

The bleaching of wool and animal fibres generally is a much simpler and less important operation than is the whitening of vegetable fibres. Wool is covered with a peculiar varnish or greasy matter which impairs its qualities, and which it is the object of the bleacher to remove. To this varnish the name of "yolk" or "suint" is given. It is a fatty unctuous matter, chiefly derived from the cutaneous perspiration, but, no doubt, also secreted by the pores of the wool itself; and it imparts that peculiar heavy odour to sheep with which all must be familiar. From the researches of Vauquelin it would appear that this unctuous varnish consists chiefly of a kind of soap, together with a small quantity of waxy matter, a peculiar odorous animal substance, a mixture of potash salts, and a little lime. This varnish, in consequence of its soapy nature, is soluble in water, so that washing in pure water would remove the greater portion of it; but it is found more advantageous to remove it by the process termed "scouring."

Scouring is performed by means of an ammoniacal lye, prepared of river or other soft water mixed with stale purified urine, which is found to contain a large quantity of ammonia, upon which its action probably depends. The mixture is heated by steam to a temperature at which the hand of the workman can be easily held in it for a considerable time. In this bath the wool is left for from half an hour to two hours, according to the quantity of greasy matter it contains. It is then to be taken out and drained into a basket, so that the drainings may drop into the vessel in which it was steeped, that nothing may be lost. It must now be completely rinsed by exposing it in baskets to a continuous stream of clear water, while a workman is perpetually employed in stirring it with a pole, till the water passes off perfectly clear. As a substitute for urine pig's dung is sometimes used, and various other substances have been proposed and introduced, such as ammoniacal salts, soda-ash, phosphate of soda, and soluble glass. Recently a machine, Petrie's wool-washer, has been introduced for scouring wools. It consists of a range of three or four long tanks, clean water entering at one end of the series and flowing through the whole. The wool is introduced at the end of the range where the water escapes, and where it is consequently most highly charged with the impurities of the washing process, and it is carried forward from one tank to another till it is lifted out at the point where the pure water enters.

It is known that the wool is properly scoured by its filaments being smooth, long, slender, white, and perfectly free from foreign substances, and not having lost their natural tenacity. If this scouring be properly done there is no need of further washings in soaps, or otherwise, till the wool is subjected to the process called "sulphuring;" and in point of fact it is very rarely passed through any other process. Some, however, recommend for the finer wools, where a very delicate white is wished, that they should be passed through one, two, or more baths of soft soap. No caustic

alkaline lyes can be employed, as they destroy the wool altogether, dissolving it, and forming with it a kind of soap.

The process of sulphuring is applied to yarns and woven goods only when they are intended to be finished white or light bright colours. Formerly, the method of sulphuring woollen goods was to expose them in a close apartment to the vapour of burning sulphur. The goods were hung on poles, and when the chamber was filled, a quantity of sulphur placed in very flat and broad dishes was allowed to burn away gradually in the chamber, while every aperture by which the vapour could escape was carefully closed. After exposure to the sulphurous acid vapours from six to twenty-four hours the bleaching process was complete, and the goods withdrawn from the chamber. The same process is now much more expeditiously performed by Thom's sulphuring process. The goods are passed on a long chain up and down over a series of rollers in a small chamber filled with sulphurous acid vapours, and a few minutes suffice for the operation. Sulphite of soda acidified with hydrochloric acid is also used in France for the bleaching of woollen fabrics.

Cloth which is to be finished white after the sulphuring process is run through a bath containing some indigo carmine, which increases the brilliancy of the white. When it is to be dyed it is treated with dilute sulphuric acid, thoroughly washed, and dried.

#### BLEACHING OF SILK.

Raw silk is covered with a kind of varnish, the nature of which was first thoroughly investigated by M. Roard. He showed that this varnish, instead of being a gum, as was usually believed, resembled a mixture of bees' wax and oil, with a resinous colouring matter, and in raw silk constituted 23 or 24 per cent. of the weight. The varnish is soluble in water, and affords a solution which forms a lather like soap. The yellow varnish is of a resinous nature, and is insoluble in water, but is soluble in alcohol. The waxy substance exists in all silks, but the whiter the silk the less wax does it contain.

The comparative composition of yellow and white raw silk is shown by M. Mulder's analysis:—

	Yellow.	White.
Fibroine.....	53.87	54.04
Gelatine.....	20.66	19.08
Albumen.....	24.43	26.47
Wax.....	1.89	1.11
Colouring matter.....	0.05	...
Fatty and resinous matter.....	0.10	0.20

This varnish, or "gum," as it is technically called, gives the silk a stiffness and elasticity which, for many of the purposes to which silk is applied, it is desirable to remove. This is called "ungumming" by the bleachers of silk. Though many different processes have been suggested for this purpose, none seems to answer so well as the old process of scouring in a weak solution of soap. If, however, the silk be kept in the soap too long after the varnish is removed, it begins to lose body, and has its qualities impaired, becoming dull, stiff, and discoloured, in consequence of being partly dissolved. White or yellow silks may be completely scoured in one hour in the soap bath, using about 15 lb of water for each pound of silk, and a suitable quantity of the finest soap. The soap and silk should be put into the water half an hour before it is brought to the boiling point, and then be boiled one hour. They are then removed, wrung out, washed in pure water, and either exposed to the vapour of sulphur or passed through a solution of sulphurous acid gas in water.

The following is the process usually followed by the scourer of silks. A quantity of water is put into a boiler over a fire, and for every 100 lb of silk to be scoured, 30 lb

of very fine soap are dissolved. The solution is generally boiled; but before the silk is put into it, the heat must be lowered to about 90° Fahr., and at this temperature it must be kept during the process. The silks are to be hung in the liquor on rods or frames, and left till the gum is sufficiently destroyed,—care being taken to alter their position now and then, so that every part may be exposed to the action of the bath. When perfectly un gummed, they are flexible and of a dull whiteness; in this state they are to be wrung out to clear them of the soapy water, then well shaken, and put into coarse linen bags, in parcels of from 20 to 30 lb each.

These bags are now to be steeped in a fresh bath, or, as the workmen say, are to be baked. The bath is prepared in a manner and proportion much as before, except that the quantity of soap may be somewhat diminished as the heat is to be increased; for the silk is now to be boiled for an hour and a half, taking care to keep the bags from sticking to the bottom of the boiler, by frequently stirring them with a stick. For silk that is intended to be dyed, the former steeping in the lukewarm soap-bath is unnecessary, and the boiling only is employed, using a greater quantity of soap in proportion to the fineness of the colour. After boiling the silk is wrung as before, and then washed, and if it is found to be not sufficiently or not uniformly scoured, it must be submitted to a fresh bath.

The white silk usually sold has a bluish shade given it by a bath impregnated with litmus or indigo. This is prepared by dissolving a pound and a half of fine soap in about 90 gallons of water, in which a small quantity of litmus or indigo has been diffused. This process gives to the silk the tints known by the names of "silver white," "azure white," and "thread white," according to the depth of shade which has been imparted. The "China white" tint is given by adding arnotto to the bath instead of indigo.

From these processes the silk acquires a tolerably clear white, but the highest degree is given to it by the action of sulphurous acid, the silk being either, as is usually the case, subjected to the acid in the state of vapour, or immersed in a solution. At Lyons no soap is used in the tinting process; but, after being boiled, the silk is washed, wrung dry, sulphured, and then passed through water properly blued.

#### BLEACHING OF BEES'-WAX, &c.

Bees'-wax in its raw condition, as it is first melted up from the comb, is a yellowish coloured substance somewhat greasy to the touch, and having a faint honey-like odour. It often contains mechanical impurities, besides traces of honey, and to remove these and discharge the colour the following process is adopted:—The wax is broken up into small pieces and melted in a copper boiler, with water sufficient to keep it from burning. When melted it is run into a tub containing hot water, and while in the hot fluid condition the mechanical impurities it may have contained subside to the bottom. From this tub the melted wax flows

into a vessel, the bottom of which is perforated with small holes. Through these thin streams of wax are received on a cylinder kept revolving in water below; and thus fine threads of solid wax are produced. These are exposed on moistened sheets to the air and light for some days, during which they are occasionally turned and watered. By this exposure the wax loses much of its colour. It is then melted up into solid blocks and left for some time, after which the operations of melting, forming into threads, and bleaching in the light are repeated till it has attained a pure white translucent lustre, is of very firm consistency, and is free from all odour. Yellow wax is also decolorised by treatment with nitric acid, but chlorine, although it bleaches most expeditiously, is not available, as it leaves traces incorporated with the wax, which on burning evolves irritating fumes of hydrochloric acid. Palm oil, used in the manufacture of soap and candles, is bleached by the action of bichromate of potash and acid.

For bleaching generally, but especially for the bleaching of animal fibres and substances, the use of a considerable variety of processes, and of chemicals other than chlorine and sulphur compounds, have from time to time been proposed and to some extent put into operation. To some of these proposals incidental allusion has already been made, and generally their success has not been such as to warrant special notice. Among other substances which have been recommended for scouring wools and silk are feeble solutions of sulphides of sodium and of potassium, or aluminates of these alkalies, the cyanide of potassium, and a mixture of common salt and oxalic acid. The alkaline permanganates have also been frequently regarded as hopeful bleaching chemicals; and a few years ago the permanganate of potash was introduced and used by MM. Tessié du Motay and Maréchal, who, in connection with the permanganate, used a solution of the peroxide of hydrogen. To this latter substance a peculiar bleaching application has recently been given. Under the name of *golden hair water*, or *auricome*, a liquid is sold by hair-dressers which is found to hold in solution a large percentage of peroxide of hydrogen. The use of this solution gives to the hair the brilliant golden yellow tinge which has come to be regarded as a highly fashionable colour. Other applications of this powerful oxidising and reducing agent have been suggested by its toilet use, and it has been employed for the bleaching of ornamental feathers, hair, &c. Doubtless, if it could be prepared in stable solution at moderate price it would be found extensively useful in bleaching and other industrial applications. It has also long been hoped that a means of applying ozone as a direct bleaching agent might be devised, but hitherto little success has been attained in this direction. In Germany ivory is bleached by steeping it a week in light naphtha or ether volatile oil, and exposing it thereafter to the air and sunlight, by which the atmospheric oxygen becomes ozonized in contact with the ivory and thus whitens it. (J. P. A.)

BLEEK, FRIEDRICH, one of the greatest Biblical scholars that Germany has produced in modern times, was born on the 4th July 1793, at Ahrensböck, in Holstein, a village near Lübeck. While attending the elementary school there, he gave evidence of such ability that his father sent him, after he had acquired some knowledge of Latin and Greek, in his sixteenth year, to the gymnasium at Lübeck, where he spent three years, and there imbibed so great a love for the languages of antiquity, that he abandoned the idea of a legal career, which he had once entertained, and resolved

to devote himself to the study of theology. After spending some time at the University of Kiel, he repaired to Berlin, and there, from 1814 to 1817, enjoyed the instructions of De Wette, Neander, and Schleiermacher. The teaching of these distinguished men, especially of the last named, exercised a decisive influence upon the whole of his after life. So highly were his merits appreciated by his professors—Schleiermacher was accustomed to say of Bleek that he possessed a special *charisma* for the science of "Introduction"—that in 1818, after he had passed the

necessary examinations for entering the church, he was recalled to Berlin to occupy the position of *Repetent* or tutor in theology, a temporary post which the theological faculty had obtained for him, with a view of retaining his services in connection with that department of the university. In this position, besides discharging his duties in the theological seminary, he published, in Schlieiermacher's and Lücke's *Journal* (1819, 1820, 1822), two dissertations, one on the "Origin and Composition of the Sibylline Oracles," and another on the "Authorship and Design of the Book of Daniel." These articles attracted much attention, and were distinguished by those qualities of solid learning thorough investigation, and candour of judgment, which characterized all the productions of his pen. Bleek's merits as a rising scholar were recognized by the minister of public instruction, who continued his stipend as *Repetent* for a third year, and promised further advancement in due time. But the attitude of the political authority underwent a change. The excitement caused in academic circles by the dismissal of De Wette from his professorship in 1819, in consequence of certain injudicious expressions in the letter of sympathy which he had written to the mother of Sands, the murderer of Kotzebue, had not died out, and the odium and punishment which fell upon De Wette were shared in a greater or less degree by his friends. Bleek, who had been a favourite pupil of the banished professor, incurred the suspicion of the Government as one who was believed to hold extreme democratic opinions. Not only was his stipend as *Repetent* discontinued, but his nomination to the office of extraordinary professor, which had already been signed by the minister Altenstein, was withheld for two years. The mystery at last was cleared up. Bleek had been confounded with another individual of a similar name, one Beuseleven Blech. Tardy justice was at length done, and in 1823 Bleek received the appointment to which his merits so well entitled him.

During the six years that Bleek remained at Berlin he twice declined a call to the office of ordinary professor of theology, once to Greifswald and once to Königsberg. In 1829, however, he was induced, on the death of Lücke, to accept his chair in the recently-founded university of Bonn, and entered upon his duties there in the summer of the same year. For the space of thirty years he laboured with ever increasing success, attracting students to his lectures, not by any attractions of manner nor by the enunciation of novel or bizarre opinions on theological subjects, but by the soundness and thoroughness of his investigations, the remarkable impartiality of his critical judgments, and the exceeding clearness of his method of presentation. In 1843 he was raised to the office of consistorial councillor, and was selected by the university to hold the office of rector, a distinction which has not since been conferred upon any theologian of the Reformed Church. After a long and honoured academic life he died suddenly of apoplexy on the 27th February 1869, having been able to lecture to his students as usual on the previous day.

Bleek's works belong entirely to the departments of Biblical criticism and exegesis. His great merits as a critic and exegete consist, as has been already observed, in the thoroughness of his investigations, and especially in the candour of his judgment. The latter quality, indeed, he possessed in so remarkable a degree, that, as a recent writer has remarked, it has become "proverbial." His views, indeed, on questions of Old Testament criticism would be regarded in this country as those of the "advanced" school; for on all the disputed points concerning the unity and authorship of the books of the Old Covenant he was led to form conclusions opposed to received opinions. But with respect to the *New Testament*, his position was highly conservative. His defence of the genuineness and

authenticity of the gospel of St John is still regarded as the ablest that has yet appeared; and although, on some minor points, his views did not altogether coincide with those of the traditional school, his critical labours on the *New Testament* must nevertheless be regarded as among the most important contributions to the maintenance of orthodox opinions that the present century has produced. Bleek's works were published partly during his lifetime, and partly after his death. His greatest work, his commentary on the epistle to the Hebrews (*Brief an die Hebräer erläutert durch Einleitung, Uebersetzung, und fortlaufenden Commentar*) appeared in three parts, in 1828, 1836, and 1840 respectively. Of it De Wette said that "It was so distinguished for comprehensive learning and thorough untiring industry, for so pure and transparent a love of truth and so profound a theological feeling, that it was entitled to one of the foremost, if not the very foremost, place among the exegetical works of our time;" and Delitzsch adds that "every one acquainted with the subject will endorse the judgment." This work was abridged by Bleek for his college lectures, and was published in that condensed form after his death by Pfarrer Windrath in 1868. In 1846 he published his contributions to the criticism of the gospels (*Beiträge zur Evangelien Kritik*, pt. i.), which contained his defence of St John's gospel, and which arose out of a review of Ebrard's *Wissenschaftliche Kritik der Evangelischen Geschichte*.

After his death were published—(1), his *Introduction to the Old Testament (Einleitung in das Alte Testament)*, 8d edition, by his pupil Prof. Kamphausen, 1869, English translation, by Venables (from 2d edition), 1869; (2), his *Introduction to the New Testament*, 8d edition, Mangold, 1876, English translation, by Urwick, 1869, 1870; (3), his *Exposition of the first three Gospels*, by Holtmann, 1862; (4), his *Lectures on the Apocalypses*, English translation, 1876. Besides these there has also appeared a small volume containing *Lectures on Colossians, Philemon, and Ephesians*, Berlin, 1866. Bleek also contributed many articles to the *Studien und Kritiken*. For further information as to Bleek's life and writings the reader is referred to Kamphausen's article in the *Darmstadt Allgemeine Kirchenzeitung*, 1869, No. 20; to the same writer's article in Herzog's *Real-Encyclopädie*, vol. xix.; and to Lichtenstein's *Histoire des Idées Religieuses en Allemagne*, vol. iii.; and to Diestel's *Geschichte des Alten Testaments*, 1869. (F. C.)

BLEEK, WILHELM HEINRICH IMMANUEL, son of the preceding, distinguished by his researches in African philology, was born in 1827 at Berlin. He studied first at Bonn and afterwards at Berlin, where his attention was directed towards the philological peculiarities of the South African languages. In his doctor's dissertation (Bonn, 1851), *De nominum generibus linguarum Africa Australis*, he endeavoured to show that the Hottentot language was of North African descent. In 1864 his health prevented him accompanying Baikie in the expedition to the Niger; but in the following year he accompanied Bishop Colenso to Natal, and was enabled to prosecute his researches into the language and customs of the Kaffres. Towards the close of 1856 he settled at Cape Town, and in 1857 was appointed interpreter by Sir George Grey. In 1859 he was compelled by ill-health to visit Europe, and on his return in the following year he was made librarian of the valuable collection of books presented to the colony by Sir George Grey. In 1869 he visited England, where the value of his services was recognized by a pension from the Civil List. He died at Cape Town on the 17th August 1876. His works, which are of the first importance for African and Australian philology, consist of the *Vocabulary of the Mosambique Language*, Lond., 1856; *Handbook of African, Australian, and Polynesian Philology*, Cape Town and Lond., 3 vols., 1858-63; *Comparative Grammar of the South African Languages*, vol. i., Lond., 1869; *Reynard the Fox in South Africa, or Hottentot Fables and Tales*, Lond., 1864; *Origin of Language*, Lond., 1869.

**BLLENHEIM** (German, *BLINDHEIM*), a small village of Germany, in the kingdom of Bavaria, and circle of Swabia, situated on the left bank of the Danube, a few miles below Hochstädt. It is only remarkable as the scene of the defeat of the French and Bavarians, on the 13th of August 1704, by the English and the Austrians under the duke of Marlborough and Prince Eugene. Population, 751.

**BLLENHEIM HOUSE**, a princely mansion erected by Parliament for the duke of Marlborough at Woodstock, near Oxford, and, with the manor of Woodstock, settled on the duke and his heirs, in consideration of his military services, and especially his decisive victory at Blenheim. The large sum of £500,000 was voted for the purchase of the manor and the erection of the building, which, notwithstanding the strictures of Swift and the criticisms of Evans and Walpole, is a magnificent pile, built by Sir John Vanbrugh, in a massive Italo-Corinthian style. The front from wing to wing extends to 348 feet; and the great hall is a lofty and noble apartment in good proportions. There are a considerable number of fine pictures in the Blenheim collection, the most noted being "The Young St Augustine and Pope Gregory," by Titian; "Europa," "Esther," and "The Massacre of the Innocents," by P. Veronese; "St Jerome," by Tintoretto; "Magdalen," by C. Dolce; many historical subjects, by Rubens; portraits by him and Vandyck; and "The Woman taken in Adultery," and "Isaac blessing Jacob," by Rembrandt.

**BLESSINGTON, MARGARET POWER, COUNTESS OF**, novelist and miscellaneous writer, was born near Clonmel, Tipperary, Ireland, September 1, 1790. Her childhood was made unhappy by the bad temper, improvidence, and loose living of her father, and by the reduced circumstances of the family. Her early womanhood was made unhappier still by her compulsory marriage at fifteen to one Captain Farmer, whose drunkenness involved him in debt, and whose debts brought him to the King's Bench prison, where he was killed by a fall in one of his drunken fits, in October 1817. His wife had some time before left his house, and in February 1818 she was married a second time to the earl of Blessington. Celebrated for her wit, her literary accomplishments, her generosity, and her social attractions, she was no less distinguished by her passion for pleasure and her craving for show and a high style of living. In the gratification of these tastes debts were accumulated, and the estates of the earl soon became burdened with "incumbrances." In the autumn of 1822 they set out on a Continental tour, and remained abroad till the death of the earl, which took place at Paris in May 1829. Some years earlier they had become acquainted with Count Alfred d'Orsay, a man of fashion and seeker of pleasure, who was then serving in the army, but quitted it for the sake of joining them. In 1827 he had connected himself with the family by his marriage with the only daughter of the earl by a former wife. After Lord Blessington's death Count d'Orsay, who had separated from his wife, came to England with the countess, and they lived together in London till her death. The home of the beautiful and brilliant countess (first Seamore Place, and afterwards Gore House, Kensington) became a centre of attraction for whatever was distinguished in literature, learning, art, science, and fashion. Ambitions of the distinction of authorship, Lady Blessington had published in 1822 her first work entitled *Sketches*, in two volumes. Ten years later she made herself favourably known by a *Journal of Conversations with Lord Byron*, which appeared first in successive numbers of the *New Monthly Magazine*, and soon afterwards as a separate work. This was followed by a long series of works, most of them novels of high life, several of which obtained considerable popularity. Her *Idler in Italy* and *Idler in*

*France* were rendered temporarily attractive by personal gossip and anecdotes, descriptions of nature, and sentiment. Lady Blessington was for some years editor of Heath's *Book of Beauty* and the *Keepsake*, the popular annuals of the day, and also contributed largely to magazines and newspapers. Early in 1849, in consequence of failing resources, the splendours of Gore House were extinguished; its furniture and decorations were sold to pay debts, and its presiding genius withdrew to Paris, whither her friend Count d'Orsay had previously gone. She died there, June 4, 1849. Her *Literary Life and Correspondence*, 3 vols., edited by R. R. Madden, appeared in 1855.

**BLICHER, STEEN STEENSEN**, Danish lyrical poet and novelist, was born at Vium in Viborg, Jutland, on the 11th October 1782. He was extremely delicate in constitution, and after having passed a year or two at the university, which he joined in 1799, was compelled to give up his studies on account of a consumptive complaint. He accepted a situation as tutor in a family at Falster, and by vigorous physical exercise and flute-playing succeeded in restoring himself to health. He afterwards returned to the university, and completed his course in 1809. Several years were then spent at his father's parsonage, preparing for the ministry and managing the farm. In 1819 he was called to the church of Thorning, and in 1825 to a more remunerative charge at Spentrup. Here he died in 1848. Blicher was first known by his translations of Ossian, but his early poems did not attract much attention. He then contributed to a literary journal, the *Nordlyset*, in which appeared the first of his Jutland tales (*Jydsk Romanser*). The popularity of these romances was surpassed by that of the *National Noveller*, which give an admirable picture of country life in Jutland. His collected poems, some of which had appeared as early as 1814, were published in 2 vols., 1835-36; the novels appeared in 5 vols., 1833-36. A short sketch of his own life and character was prefixed by him to the complete collection,—*Old and New Novels (Gamle og nye Noveller)* 7 vols., 1846-47. Blicher also translated Goldsmith's *Vicar of Wakefield*.

**BLIDAH**, the chief town of an arrondissement in the province of Algiers in Algeria, about 30 miles inland from the capital, on the railway from that city to Oran. It lies at the base of the Algerian Atlas, in the midst of the fertile plain of Metija, and is beautifully surrounded with orchards and gardens, which afford a pleasant contrast to its ramparts and towers. It has well-built modern streets with frequent arcades, and numbers among its buildings several mosques and churches, a Franco-Arabic and a Protestant school, extensive barracks, and a military hospital. Water is abundantly supplied by an aqueduct fed by the Oued-el-Kebir. As the centre of a flourishing district and a post on one of the main routes in the country it enjoys an extensive traffic, and the inhabitants maintain a thriving trade in oranges, raisins, grain, cotton, and tobacco. The products of the neighbouring copper-mines and of the cork-tree and cedar-groves are also of importance. In the vicinity are the two villages of Joinville and Montpensier, which owe their origin to the military camps established by Marshal Valée in 1838; and on the road to Medeah are the tombs of the Marabut Mohammed-el-Kebir and his two sons. Blidah was a town of some importance under the Turks, but in 1825 it was nearly destroyed by an earthquake. It was not till 1838 that it was finally held by the French, though they had been in possession for a short time eight years before. In 1867 it suffered from another earthquake which also nearly ruined the village of Chiffa. Population in 1872, 8113.

**BLIGH, WILLIAM**, admiral, was born of a good family in the south of England in 1754. He accompanied Captain

Cook in his second expedition as sailing-master of the "Resolution," and in 1787 was despatched to the Pacific in command of H.M.S. "Bounty," for the purpose of introducing into the West Indies the bread-fruit tree from the South Sea Islands. Bligh sailed, in 1787, from Otaheite, where he had remained about six months; but, when near the Friendly Islands, a mutiny broke out on board the "Bounty," headed by Fletcher Christian, the master's mate, and Bligh, with eighteen others, was set adrift in the launch. This mutiny, which forms the subject of Byron's *Island*, did not arise so much from tyranny on the part of Bligh as from attachments contracted between the seamen and the women of Otaheite. After suffering severely from hunger, thirst, and storms, Bligh and his companions landed at Timor in the East Indies, having performed a voyage of about 4000 miles in an open boat. Bligh returned to England in 1790, and he was soon afterwards appointed to the "Providence," in which he effected the purpose of his former appointment by introducing the bread-fruit tree into the West India Islands. He showed great courage at the mutiny of the *Nore* in 1797, and in the same year took part in the battle of Camperdown, where Admiral Duncan defeated the Dutch under De Winter. In 1801 he commanded the "Glatton" at the battle of Copenhagen, and received the personal commendations of Nelson. He was subsequently made governor of New South Wales, and vice-admiral of the blue. He died at London in 1817. He was an active, persevering, and courageous officer, although, perhaps, somewhat exacting in his manner.

**BLIND.** The blind, as a class, are limited to such narrow spheres of action that those unacquainted with the subject fail to realize how large a number of the human race are deprived of sight. In the temperate regions of the globe about 1 in every 1000 of the population is blind, but in less favourable climates the percentage is much greater. When we consider what medical skill has already accomplished in Europe and America, not only for the relief but the positive prevention of blindness, we may readily conclude that in warmer and less civilized countries the class is more numerous and their condition more deplorable.

We rejoice that much can still be done by proper care and treatment to prevent blindness; for instance, ophthalmia of infants is a very common cause, and ought not to terminate in loss of sight, which in most cases results from neglect and dirt. Glaucoma is also a fruitful source of blindness, invariably causing loss of sight if left to itself; but, thanks to Professor Grife's brilliant discovery, these cases are generally curable if operated on early. Another very common cause of blindness is serious injury to one eye, which is thus lost, and if the injured organ be not at once removed, sympathetic inflammation and destruction of the other is very apt to follow, resulting in total blindness; whereas, if the injured eye be at once removed the other is generally preserved.

Loss of sight from small-pox is now comparatively rare, owing to the general practice of vaccination, but much undoubtedly may still be done towards diminishing the frequency of blindness by further advances in the art of treating eye-disease, and especially by spreading among all classes a knowledge of what has already been done in this direction.

It often occurs that children become blind through the most trivial causes by parents consulting unskilful practitioners. The improvement and increase in the number of well-regulated hospitals now makes it possible for every parent, however poor, to have the best medical advice and attendance.

In all ages of the world the blind have been the objects of pity and commiseration, yet it has only been within the

past century that Christian civilization in its grand onward march has taken them in its embrace, and shed the influence of its light upon their midnight darkness. During recent years leading philanthropists have given much earnest thought to the best methods of ameliorating and improving the condition of the blind. Nearly all the European Governments and the States of the American Union have made liberal provision for their education and special training. In Great Britain the work has been left thus far to charitable enterprise. Much, however, has been done,—almost every large town having its asylum, workshop, or home teaching society.

The following summary, from *A Guide to Institutions and Charities for the Blind*, prepared by M. Turner and W. Harris in 1871, will show the state of these institutions at a recent date:—

"In the year 1800 there were only four institutions for the blind in the United Kingdom; during the next thirty years six others were added to the list; in the succeeding thirty years seventeen more were opened; while within the last ten years twenty new ones have been established, making a total now of fifty-three, without including societies for visiting the blind at their homes, and other charities.

Scotland with five institutions sold, in the last year of which we have any report, goods of the value of £31,930, while England with forty institutions only sold in the same period goods of the value of £38,598; and Ireland, only £454.

Scotland provides for, on an average, 76 blind in each institution; while England only provides for 48, and Ireland for 60.

The donations and subscriptions in Scotland for the same year amount to more than £20 per head of the number benefited; while in England they amount to about £21, and in Ireland to about £16.

So far as returns have reached us, it appears that Mr Moon's system of reading for the blind is adopted by 38 institutions and home-teaching societies, while only 22 use the books of other systems—Lucas's, 7; Roman, 4; Alston's, 4; Frere's, 3; Braille, 4. [Since 1871 the use of Braille has been introduced into many other institutions.]

Of the 30,000 blind in the United Kingdom, there are only about 2250 being instructed or assisted to work. The total amount received per annum for the benefit of the blind, according to the answers received, is about £66,000; besides, there are twelve societies from which no return has been made. Of institutions for the blind generally, we may remark that in each institution nearly the same difficulties appear to exist, the principal one being the difficulty of selling the goods manufactured at such prices as will secure a ready sale and cover the cost of production, and consequently in most instances there is a large surplus stock. In cases where the stock is wholly disposed of, our observations lead us to think that sales have been secured by selling at a loss.

The principal trades practised by the blind in the United Kingdom are the making of baskets, brushes, brooms, mattresses, rugs, mats, casing of chairs, with knitting and sewing for women."

Within a few years a great impetus has been given in England to the higher education of the blind, by the formation of the British and Foreign Blind Association, the establishment of the College for the Blind Sons of Gentlemen at Worcester, and the Royal Normal College and Academy of Music for the Blind, Upper Norwood.

The first-mentioned association "has been formed for the purpose of promoting the education and employment of the blind, by ascertaining what has been done in these respects in this and other countries, by endeavouring to supply deficiencies where these are found to exist, and by attempting to bring about greater harmony of action between the different existing schools and institutions.

"The founders of the association took as an axiom that in all questions which relate to obtaining impressions by touch the blind are the best judges; the council of the association therefore consists entirely of gentlemen who are either blind, or so nearly so that they have to use the finger instead of the eye for the purpose of reading.

"One main difficulty in the way of educating the young blind is the great cost of most of the appliances; this the council have endeavoured to meet by the manufacture of cheaper and better apparatus than any hitherto in use.



No one who has not made the attempt can have any idea of the extreme difficulty of combining great accuracy and durability with cheapness. This has been in a great measure accomplished as regards the Braille writing frames, which are now within the reach of every blind person who wishes to avail himself of the advantages of writing. The fact that a large number of these frames has been already sold speaks for itself, and, as the great majority of the purchasers are poor, the quick sale is evidence not only of the cheapness of the frames, but also of the widespread desire for self-education existing among the blind.

"Another obstacle to the diffusion of the knowledge of the Braille system has been the absence of printed books in English. With the view of meeting this want one of the council has perfected the process of stereotyping used in France, by which the cost of production of stereotype plates is greatly reduced; and as the blind can themselves produce these plates, a new and remunerative means of employment has been discovered. Some school books have already been issued by the association, and will shortly be followed by others. The work on the *Education and Employment of the Blind*, by the honorary secretary, has been published under the sanction and at the expense of the association."

The following extract from an address delivered by the honorary secretary before the Society of Arts on the various types for the blind, shows how thoroughly they are investigating the subject:—

"The happy idea of printing on paper letters recognisable by the touch is due to M. Hatty of Paris, who printed his first book in 1784, and founded the Institut des Jeunes Aveugles, Paris. The type he adopted was the script, or Italic form of the Roman letter. This was introduced into England by the present Sir C. Lowther, who printed the gospel of St Matthew in 1832 with type obtained from Paris, and followed it with other portions of the Bible. In 1834, Gall, of Edinburgh, printed the gospel of St John in Roman capitals, in which, however, all curves were replaced by angular lines, and the lines themselves were serrated, which changes, he believed, gave greater distinctness to the letter.

Alston, of Glasgow, adopted Fry's plan of using ordinary Roman capitals. Dr Howe, of Boston, U.S., makes use of the small Roman letters, giving them angularity according to Gall's idea.

The Philadelphia type does not differ much from Alston's. The combination of capitals with small letters has also been tried, and a society has recently been formed at Worcester with the intention of printing on a large scale in this type. In Germany various modifications of the Roman letter exist, the principal of which, the so-called Stachelschrift of Stuttgart, consists of Roman capitals formed by finely dotted lines. All these modifications are suggestive of the strong tendency among those who have attempted to benefit the blind to retain for them the form of letter to which the seeing are accustomed, while the constant change of form indicates a fact with which most blind persons are familiar from personal experience, viz., that none of these modifications are satisfactory as to the primary condition of being easily felt. A better form than any which has obtained currency was suggested twenty years ago by Mr Welch, a blind man, who has been the pioneer of education amongst the blind of London, and this is almost identical with one independently worked out by Mr Littledale of Cheltenham.

The second great class is made up of alphabets deviating more or less widely from the Roman letter, and consists of a stenographic shorthand invented by Mr Lucas, a phonetic shorthand due to Mr Frere, and a full writ system introduced by Mr Moon, in which the Roman letter is retained in a more or less modified form whenever he considered this could be done compatibly with easy recognition, the simple line-signs employed by Mr Frere being used to replace the more complicated of the Roman letters. It will be necessary to examine these systems in detail, and it will facilitate this examination if we compare them with each other in the following particulars:—(a.) As respects the shape of the letter; (b.) As respects the advantage of conformity with the Roman letter; (c.) As regards the reading from right to left and from left to right alternately; (d.) Advantage of a shorthand as contrasted with a full written system.

(a.) *As respects the shape of the letter.*—Mr Lucas and Mr Frere brought out their systems about the year 1838, Lucas preceding Frere by a few months. They employed at first almost identically the same characters, but unfortunately could not agree to represent the same sound by the same symbol. Mr Frere had the advantage

of having his plan carried out by a very ingenious and sensible blind man, who soon discovered that the letters formed by lines and curves upon which dots were placed were too similar to those formed by the corresponding lines and curves without dots; he, therefore, changed all his dotted characters, replacing the dotted curves by angles of 45°, and the dotted lines by lines in which a short line is substituted for the dot.

The result of this change is, that Frere's character is now far superior to Lucas's in the quality of easy recognition. Mr Moon's character, in the large size which is used by him, is quite as easily distinguishable as Frere's, but in the form in which he now prints his characters, his right-angles are not true right-angles, but are rounded. In the size which he uses, this defect is of very little importance, but it effectually prevents any considerable diminution, because, if this is attempted, the rounded right-angles cannot be distinguished from the hooked lines.

The importance of using a character as small as is compatible with easy recognition may be readily understood from the following statement:—The largest type used by Mr Frere is that employed in the gospel of St John. The character is 44-sixteenths of an inch long, and is about the same size as Moon's character. The pages occupied by the gospel of St John in Frere are 96. In his medium type, in which the length of the letter is 4-sixteenths of an inch, the same matter would go into 67 pages; and in his smallest type, in which the length of the letter is 34-sixteenths, it would occupy 46 and a third pages. It has been found, by an experience extending over 27 years, and embracing many hundreds of individuals of all ages and conditions, that all those who can read the largest type can read the medium, and almost all can read the smallest.

The medium type is very generally preferred, as being more pleasant to the finger, and many with delicate touch prefer the smallest for the same reason. Thus it will be seen that, by selecting a well-devised character, not only can a very considerable saving be made in the size, and therefore in the cost of books, but by a diminution of size, within certain limits, the character is rendered absolutely more legible. The gospel of St John, in Moon's type, occupies 140 pages.

(b.) *As respects the advantage of conformity with the Roman letter.*—Much has been said and written on this subject. A favourite argument with the advocates of the Roman letter is, that by its use a blind man can be assisted in his reading by those around him who are possessed of sight. This, no doubt, would be valid if no simpler character for the blind had been invented, but when we have to choose between a character in the reading of which the blind can be assisted by the seeing, and one which is so simple that no assistance is required, there can hardly be a doubt as to which ought to be used.

Another plea for the use of the Roman letter is, that by its means the blind can write in a character understood by everybody. This writing is, as we shall presently see, a very imperfect process; but this argument is undoubtedly of some weight. These remarks apply simply to the existing systems in which the Roman letter is employed. It is probable that a much more legible alphabet might be constructed, but, after our 96 years of experience and experiments with the Roman letter, another failure may well be feared. The small angularised Roman letter of Dr Howe, of Boston, which is used in most of the schools of the United States, is probably as good a form as any, and if printed in a larger size would not be difficult to feel; in its present size, however, it is far too small, and has signally failed in America. The American schools are all State institutions, and have to furnish accounts to their respective State Legislatures of the work done by them.

Out of 664 pupils in seven schools, where the Roman character of Dr Howe is used, one-third learn to read fluently, one-third by spelling, while none fail; and it must be borne in mind that those who learn to read by this system also acquire an admirable method of writing. Moon's system retains those Roman letters which can be easily distinguished, and thus makes a transition between the systems in which the Roman character is used and those which employ purely arbitrary signs. For this reason, and from its great simplicity of construction, it is more easily learned than any other, and therefore is well suited to the great mass of the poor, who from want of intelligence or of application cannot learn one of the shorthand systems. Its great bulk, however, involving costliness of production and comparative slowness of reading, is a serious obstacle to its general use.

(c.) *Reading from left to right, and from right to left, alternately.*—In Frere's system the lines are read from left to right, and from right to left, alternately, an arc of a circle taking the finger from the end of the upper to the beginning of the lower line. The plan may be illustrated by imagining the letters to be fixed on the upper edge of a long string. Let it be supposed that this string is doubled backwards and forwards upon itself in such a way that the letters always occupy its upper edge. This will give a good idea of Frere's method of reversing the line; not only is the line reversed, but every letter in it is also reversed, so that the finger, when

moving forwards, whether towards the right or towards the left, the characters in the same position, and is, in fact, never moving backwards, in the same manner that a person may walk to the end of a room, turn and walk back, yet is moving forwards in both directions. Moon, on the other hand, while borrowing the reversal of the line from Frere retains the letters in the returning line in the same position as the advancing, so that the finger in the return line meets the characters in the opposite direction from that in the advancing line; and to those accustomed to Frere's simpler method of reversal an unpleasant feeling is produced, exactly comparable to walking backwards.

The following examples of both modes of reversal, in which Roman Capitals are used, will make this clear:—

*Frere's Method.*

I WILL MAKE DARKNESS  
MEHT BEFORE THIGH

*Moon's Method.*

I WILL MAKE DARKNESS  
MEHT EROFEB THGIL

No doubt habit will accustom a reader to either plan, and probably there is not much difference in the difficulty of either, but, as we shall see by-and-by, it is absolutely necessary for writing that the pupil should thoroughly understand that, whichever way he goes, he is moving forwards; it is, therefore, wise to accustom him in reading to a process which he will have to follow in writing. Opinions differ widely among the blind whether it is best to read forwards in one direction and backwards in the other, or forward in both; it seems, however, among those who have had experience of the return line, that there can be no doubt of its great value, as by its use no time is lost by the reading finger having to return from the end of the upper to the beginning of the lower line, and the setting free of the left hand enables it to follow the right in reading, to take its place, or to rest.

(d.) *Shorthand.*—By a shorthand system, reading is more rapid, and a nearer approach is made to the way in which the eye takes in a whole word at a glance, than in a full-written system. The books are also more manageable and less costly, but the stereographic method is distinctive of correct spelling, and in the phonetic method this is not even attempted; yet it is advisable, for many reasons, that the blind should be able to spell. The shorthand systems seem therefore to be of the same use to the blind as to the seeing—not being of universal application, but extremely useful to those who have to read much.

In all the systems which we have hitherto considered, the letters, whether Roman or arbitrary, are formed by raised lines. The method employed for writing them is as follows:—Small cubes of wood are used with projecting pin points, so placed as to assume the form of each letter. The paper to be written on being laid on a soft surface, the pin-point letters are pressed into it; each point carries some of the paper before it, forming a little prominence on the reverse side, and as the pin points are very close together, the series of little prominences formed by them feel to the fingers like serrated lines. This plan ought rather to be called printing than writing. It requires great practice, and is at the best very slow and imperfect; yet it has its use, as by employing Roman capitals the blind can correspond with the seeing. The letters, however, are not sufficiently distinct, and communications from blind correspondents written in this manner, or with pencil, are less satisfactory, both to writer and reader, than if the letter had been written from dictation. Printing from the Roman letter (not embossed) can be effected by the blind, with considerable rapidity, by means of Hughes's typograph or Feneault's writing-machine; but the blind writer cannot read what he has written, and the apparatus is so costly that it is not procurable by the poor.

[A new machine called 'the type-writer,' has lately been invented in America. It is largely manufactured, and is coming into general use for the seeing. It is equally well adapted to the use of the blind. It is very simple, and can be manipulated very rapidly. A skillful operator can write at least twice as fast as an expert penman. It is not only a valuable invention, but one superior to all others of the kind.]

Various plans exist to enable the blind to keep their lines when writing with a pencil or with a stile on carbonized paper, but such writing can only be used for correspondence with the seeing, and cannot, of course, be read by touch.

We come now to the third class of systems, viz. those in which the letters are formed by a combination of dots. These are:—

1. The Braille system, universal in France, both for writing and printing, and very much used for both purposes in Switzerland, and employed as the *written* character in almost all countries, with the exception of the United Kingdom.

2. The Carton type, which was introduced into Belgium by the Abbé Carton.

3. Hughes's system consists of large and small dots, and lines placed in different positions. It never obtained much currency, and

seems never to have attracted the attention which its ingenuity merited.

4. A modification of the French method has been lately proposed in New York, and seems to have much to recommend it.

To begin with the French method. This was invented in 1834 by M. Braille, a blind pupil of the *Institut des Jeunes Aveugles*. It spread with great rapidity, and has, as we have before seen, become almost the universal written language of the blind. Its signs are purely arbitrary and consist of varying combinations of six dots placed in an oblong, of which the vertical side contains three and the horizontal two dots. For writing, a frame is used consisting of a grooved metal bed, containing ten grooves to the inch; over this is fitted a guide whose vertical diameter is  $\frac{1}{4}$  inch, while the horizontal diameter is  $\frac{1}{2}$ . This perforated guide is fixed into a light wooden frame, like the frame of a slate, which is attached to the grooved metal bed by hinges. The paper is introduced between the frame and the grooved bed. The instrument for writing is a blunt awl, which carries a little cap of paper before it into the grooves of the bed, thereby producing a series of little pits on the side next the writer. When taken out and turned over, little prominences are felt, corresponding to the pits on the other side. The reading is performed from left to right, consequently the writing is from right to left; but this reversal presents no practical difficulty as soon as the pupil has caught the idea that in reading and writing alike he has to go *forwards*. The brass guide has a double row of openings, which enables the writer to write two lines; when these are written, he shifts his guide downwards until two little pins, which project from the under surface at its ends, drop into corresponding holes of the frame, when the writer writes two more lines, and this operation is repeated until he arrives at the bottom of the page.

The first ten letters, from 'a' to 'j,' are formed in the upper and middle grooves; the next ten, from 'k' to 't,' are formed by adding one lower dot behind to each letter of the first series; the third row, from 'u' to 'h' is formed from the first by adding two lower dots to each letter; the fourth row, from 's' to 'w,' similarly, by adding one lower front dot.

The first ten letters, when preceded by the prefix for numbers, stand for the nine numbers and the cypher. The same signs, written in the lower and middle grooves, instead of the upper and middle, serve for punctuation. The seven last letters of each series stand for the seven musical notes—the first series representing quavers, the second minims, the third semibreves, the fourth crotchets. Rests, accidentals, and every other sign used in music, can be readily and clearly expressed, without having recourse to the staff of five lines which forms the basis of ordinary musical notation, and which, though it has been reproduced for the blind, can only be considered as serving to give them an idea of the method employed by the seeing, and cannot, of course, be written. By means of this dotted system a blind man is able to keep memoranda or accounts, write his own music, emboss his own books from dictation, and carry on correspondence.

But this French system, though extremely useful, is not perfect. The letter is too small for ready recognition by the unskilful or hard-handed, and if this is sought to be remedied by increasing the size, the reading finger does not cover the whole of the letter, and has to proceed up and down, feeling out each letter, instead of following the even gliding motion essential to good reading. The modification proposed in New York remedies this defect, though this does not appear to have been the intention of its promoters. It proceeds on the principle that the letters occurring most frequently in the English language should be represented by the fewest number of dots, and that the letters should be so spaced that a letter composed of one dot should not, as is the case in the French system, occupy the same room as one with six dots. For this purpose the oblong, consisting of six dots, composing the root-form of the letter, is placed horizontally instead of vertically, the greatest vertical depth of any letter in two dots instead of three. From these two changes results a saving of about one-third in space; this involves a saving of about one-third in the price of printed books; writing is rendered more rapid; and as the size can now be increased, owing to the diminution of the vertical length of the letter, it can be made sufficient for the dullest touch. Ten-word and part-word signs have been introduced, which effect a further saving of nearly one-third, while they do not interfere in the least degree with correct spelling. These advantages make it well worth while to consider whether the modification of the Braille system ought not to be adopted as the written system of all English-speaking blind; but before such a step is recommended, the question should be carefully considered in all its bearings on musical notation as well as on ordinary writing."

Regarding the Worcester College for Blind Sons of the Gentlemen, founded in 1866 by the Rev. R. H. Blair, the Report informs us that—

"It was opened with the view of giving to families of the better class an opportunity of educating their children in a systematic

manner, with a due regard to home comforts, and with surroundings befitting their position.

The course of education projected by Mr Blair was such as would convert the pupils into intelligent home companions, if no other object were desired. But a conviction, based on personal knowledge, that the blind were capable of the highest competition with the seeing, lay at the root of this gentleman's endeavours. Self-helpfulness and usefulness in the ordinary affairs of life is therefore but one of the first results which reward the teaching of the blind; and it appears that blind men can be made reproductive also, not only in the particular instance, but in the bulk, and that the arts of teaching and lecturing, acting as deputations, translating, presiding over blind or other institutions, the law, and in the most favoured cases the church, are fully within the capacity of the well-educated blind. A prejudice has hitherto existed against the employment of blind men, owing to their supposed incapacity, and certain other drawbacks resulting from neglect. Let this impression be removed, and there will be an increase in the number of positions open to them.

For an entrance into these walks of life, the training must be such as to enable its recipients to compete for university distinctions. The objections to this course, if they are entertained, will be removed by a little reflection on the nature and uses of a university; and the difficulties which in the idea of inexperienced persons a blind man has to overcome, are greatly diminished by being met and grappled with in early years, and are actually being materially lessened by the earnest efforts now made by blind instructors and investigators.

It is impossible to rule definitely at what age the school education of a child born blind should begin. Children vary as much in natural quickness as parents in the power of educating. A quick and resolute child will, through the almsiveness of nurses or the carelessness of a parent, early acquire tricks which it takes years to eradicate, and acquire habits and ways of thought and action which may have a profound effect on his after life. The sooner, therefore, a child can consistently with his health and other considerations be admitted to cheerful and active society, where his character can have free play and find sympathy, yet be quietly trained, the more easy will his education be afterwards. For those who have become blind from accident or disease, in childhood or towards the age of adolescence, one word of advice may be given. As soon as it is ascertained that the blindness is past remedy, the child should be sent to school, so that the habit of study may be remitted as little as possible. It is in the highest degree impolitic to allow the faculties to degenerate through several years' disuse, as is often done; and it is in reality kinder to a child or youth to send him away to pick up strength and consolation by the example of his cheerful and patient fellows, and to distract his grief by learning the instruments which he will ultimately need in his education, than to keep him in the indulgences of home, brooding over his misfortune, or buoyed up by a hope which will not be realized.

No claim to exclusiveness is asserted in the use of English types. There are useful works to be found in all; and when a pupil arrives who has been educated in one or other form of type, he is never discouraged from its continued use. But as uniformity of class-books is desirable, and one system must be employed as a basis, the Roman form, in which are printed books suitable for higher education, is adopted for class purposes. Dr Moon's type is read by some for recreation or private study, and the American Bible, which is the most portable yet printed, and is beautifully executed, is read by those whose dexterity, acquired by long practice, enables them to master this somewhat difficult, because small, type. After some years of practice the desire for smaller type seems to become a passion for those possessed of a quick and nimble touch.

Dr Moon's type is large and easy, and comprises the Bible, Prayer Book, and a large number of religious and devotional works, together with numerous stories, biographies, and other works suitable for the young and aged. Dr Moon has also several educational works of a very useful character; but his plan of action has not yet led him to enter largely into the production of higher literature.

The Royal Normal College and Academy of Music for the Blind has for its object the affording of a thorough general and musical education to the youthful blind of both sexes who possess the requisite talent, so as to qualify them for self-maintenance. The Report of the institution states that

"As without previous trial it would in many cases be difficult to determine whether an applicant for admission has sufficient capacity for the kind of education given at the college, candidates will first be received as probationers for a term of three months, or less. If, at the end of that period, they are found to possess adequate ability, they may become permanent pupils.

With a view to adapting the methods of instruction to pupils of different ages and capacities, the following classification has been adopted, viz. :—A. The elementary section, the instruction in which

is designed especially for children from seven to nine years of age; B. The intermediate, for pupils from nine to twelve years of age; C. The junior, for pupils from twelve to fifteen years of age; D. The senior, for pupils from fifteen to twenty-one years of age. Exceptional cases over twenty-one years of age can only be admitted by special vote of the committee.

The college embraces three distinct departments—1. General education; 2. The science and practice of music; 3. Pianoforte tuning.

The department of general education embraces all the ordinary branches of a sound English education. Special care is bestowed on the intellectual training of the pupils; for experience has shown that in order to qualify the blind for self-support, it is essential to afford them a thorough general as well as musical education.

In the musical department both vocal and instrumental instruction is given, according to the improved methods which have been employed during late years with marked success in the leading institutions of France and America. This department embraces the culture of the voice, the study of the piano, organ, and other solo instruments, harmony, counterpoint, composition, the history of music, and the art of teaching.

In the department for training the pupils in the art of regulating and tuning pianos, pupils are instructed who have passed the age at which they might have become qualified for remunerative employment in other departments. Though a superficial knowledge of the art of tuning may be readily acquired by those deprived of sight, a prolonged course of careful training is necessary in order to enable them to become thoroughly successful.

Experience has shown that the blind can seldom fully support themselves merely by manual labour, and the great majority of those who have been trained to industrial trades continue to require charitable assistance during their whole life.

It is well known that many of the blind possess musical talent, yet only a small number in the United Kingdom have ever been qualified to earn their living by the profession of music.

Such was formerly the case in other countries, but during recent years great improvements in the general and musical education of the blind have been effected abroad, particularly in France and America, and large numbers of this class educated in the institutions of those countries have been enabled to maintain themselves fully by various pursuits, especially as skilled organists, teachers, pianists, and pianoforte tuners.

In view of the practical results of the improved education of the blind in other countries, the Normal College and Academy of Music was founded in order to afford similar advantages to the youthful blind of the United Kingdom.

The college was opened in March 1872, under the direction of a committee, including members of the governing bodies of various metropolitan societies and institutions for the blind, with an experienced principal, and a staff of highly-trained teachers.

Upwards of seventy pupils from London and other large towns have been under instruction; a number have already left the college, and are now regularly employed as thoroughly competent pianoforte tuners."

As it will be impossible in this article to give any lengthened account of the institutions on the Continent and in America, we will briefly sketch the plan of working in a few of the most progressive.

The following extracts from addresses delivered at the first European Congress of Teachers of the Blind at Vienna in 1873, will best give an insight into the schools of Saxony :—

Herr Reimer, superintendent of the Preparatory School for the Blind at Hubertusberg, pointed out that, "even among the families which are not very poor, blind children often grow up without learning to wash or feed themselves, with hands hanging soft and helpless at their sides, and thus become more incapable than the poorest, who are forced to exert themselves by the necessity of the case.

If they are not taught to help themselves at home, it is very difficult to teach them at school, and as the existing blind institutions cannot admit young children without injuring the education of the older ones, they ought to be taught in preparatory schools or Kindergärten separately, which should be established by the State.

In the preparatory school at Hubertusberg in Saxony, the first thing aimed at is the strengthening of the limbs, then to make the children use them properly, to make them help themselves instead of relying on others, to correct their bad habits and to improve their mental condition, arousing in their minds the love of God and of truth as well as conscience. All this must be done methodically, and each lesson must be given separately and repeatedly as well as most patiently.

The change wrought thus is wonderful, if the teachers are experienced. They must be encouraged to move about as directed, and the 'Frübel play and exercises' will be found useful. Pleading

strips of leather, and other occupations which combine play with work, are carried on with advantage. A good manager of Kindergarten can do them great good, and gymnastics give them the power of controlling their limbs; but every exercise must be first taught singly.

Object lessons must be given by means of models, stuffed animals, birds, fish, &c., to bring out the powers of memory and reason. Simple hymns and ballads are practised.

Very little technical work can be taught, except making rush baskets, &c., as the children are all under ten. This school has been carried on for eleven years, and the benefits of teaching blind children so early are plainly seen by all who watch the progress which they make when removed to the Blind Institution; they are fit for independent work at an age three years less than the average of those who do not go through it.

As the children pass through the institution more rapidly, there is also more room for those who become blind as adults."

Of the *National Blind Institution* at Dresden, Dr Reinhard, the director, said—"It is organized so that the working school forms an essential part of it, and when children enter it, consideration is at once given, not only to their physical, religious, and intellectual education, but also to their instruction in work. Whilst between the ages of six and eleven they remain in the preparatory school, and find inexhaustible occupation in Frobel's system of play and exercise.

'Playwork' is given them as they become fit for it; for the feeling that they can make something useful rejoices the little workers and excites their activity; it is important that they should learn early to aim at real work. They learn to plait reed mats, which is an excellent means of strengthening the muscles of the arm and hand, and they also make little rush baskets.

The range of their work is extended when they are transferred to the higher class, which is usually during their eleventh year; and from that time till their confirmation, which is generally at the end of their fourteenth year, they have at least three hours' work every day in the shops.

The work of the girls is, unfortunately, much restricted, and it is doubtful whether their learning to make baskets and rope is without injury to their constitution. Besides, we must not lose sight of the evils arising from their working with male overseers and workmen.

Hence, girls learn in general only knitting, plaiting counterpanes, chair-caning, hair-working, and sewing—as much as is required for mending their linen.

Hair-work has already been adopted in another institution, and is the most profitable work for blind girls, as a clever one can earn 7 or 8 groschen (about 9d.) a day by it, whilst the quickest knitter can scarcely make 2 groschen a day.

The boys learn either basket-making or rope-making; they learn in the rope factory various kinds of light work, and, when they have been confirmed, choose for themselves between these two trades, their muscles being strengthened by alternately being employed at both.

It is important to consider the grounds of fitness for these trades. Rope-making requires strength and health of body, for much of the work must be carried on in places exposed to the weather; and besides this it requires a great deal of dexterity which is not indispensable in basket-making. It is also of great importance that each should learn the trade in which he is most likely to succeed after leaving the institution; for the great object is that pupils should be fitted for independent work eventually.

All those who understand the subject are now convinced that the blind cannot be really helped by building asylums. If there were three times as many asylums as there are schools, there would not be room for all, and the inmates would never be satisfied with their condition. Even women prefer an independent life full of care to the sameness of an asylum, where one quarrelsome person often embitters the whole life of the institution.

If there is any possibility of establishing pupils of either sex without exposing them to the risk of losing their health, there can be no doubt that it is to be preferred to placing them in asylums.

"The Dresden Blind Institution is managed on the principle that the pupils, on commencing independent work, require much assistance before they can support themselves by it, and that the institution must give the necessary help. The director of the institution makes known to the manufacturers that a blind worker is coming to settle near them, and induces some of the families around to take an interest in him, and recommend him for employment. He also inserts in the newspapers short notices describing his capacity for work, and his difficulty in finding customers, &c., and requesting people to employ him.

The outfit required for pupils on leaving the institution consists of tools and clothing, and materials must also be provided at first. The cost of these is partly defrayed by the fund established for the purpose, partly by the savings of the pupils, and partly, if necessary, by a grant from the parish.

It is indispensable that the blind worker should have some person near in whom he can fully confide, and from whom he can

get advice and help in any time of temporary difficulty, whilst the manager of the institution can rely on his taking an interest in the worker, and seeing that he obeys the rules.

The purchase of new material causes the greatest difficulty; the blind man has not the means of buying much at a time, and must, consequently, pay highly for it; therefore the institution helps him by buying it at wholesale prices and letting him have it at the same price in small quantities. The number of his applications for materials shows the managers whether the man is industrious.

More than 200 blind support themselves in Saxony by means of the aid afforded by the fund and their own exertions. The fund amounted, in 1873, to 85,000 dollars, subscribed in all parts of the country."

Previous to the Franco-German War, Mr Liebreich, a celebrated oculist and practical friend of the blind, by order of the empress of the French, prepared a report in regard to the *Institution Impériale des jeunes Aveugles* of Paris, in which he says that the institution—

"Is an establishment of the State, in which children of both sexes deprived of sight receive an intellectual, musical, and industrial training. Children are received at the age of 13 years. They remain in the institution 8 years, and are made professors, musicians, tuners of pianos, workmen and workwomen.

During the last ten years 110 male pupils have left the institution, concerning whom we have received satisfactory information. The workwomen, on the contrary, earn but very little; among 168 blind, 108 have received a very good education, which ensures to them an easy and independent living; 56 have received an elementary training, and have not been put entirely beyond the charge of public charity.

The annual expense for 300 pupils is very nearly 240,000 francs (of which 146,000 francs are given by the State), making an average of 1200 fr. (£48) per pupil,—the workman costing a little less, the artist a little more. This sum is not excessive for the education of a tuner, a professor, or an organist, but it certainly is for the education of a workman, who only receives an elementary training, and is not even qualified to earn his own living.

M. Gaudet, chief instructor of the institution, expresses disapproval of the simultaneous education of artists and workmen. He says, 'Realising from the first the great difference which exists between the future of an organist or a piano tuner on one side, and of a blind workman on the other, the apprentices regard themselves as sacrificed; therefore they do all they can to become tuners, and thus often lose much time in fruitless efforts before they resign themselves to become workmen, and even then toil reluctantly. On quitting the establishment to follow their occupations, they are not habituated to assiduous toil; returning to their indigent families they regret the comfortable life of the institution, and finally become discouraged.'

Tuners begin ordinarily to work with piano manufacturers, and earn easily 1500 francs per year. If a little later they succeed in obtaining a town connection, they have no difficulty in earning double that or more. Some have even succeeded in uniting manufacture with tuning. The organists, by obtaining places in churches and by giving music lessons, very soon earn a good livelihood.

In short, the tuners, organists, and teachers have, in spite of their infirmity, become independent men, exercising honourable and lucrative professions; some have married and reared families, others have come to the aid of their indigent relatives.

Very different is the lot of the blind workmen, who by toiling without relaxation many more hours than sighted workmen, barely succeed in gaining a part of what they need to support themselves. By perfecting as far as possible the industrial training of the institution, a greater number of the male pupils might be enabled to earn 300 or 400 francs, but none far exceed this sum. The workwomen seldom earn more than 100 or 150 francs per year."

The institutions of America are not asylums, but in the truest sense of the word educational establishments, in which the blind, without regard to their future, receive a thorough education. The blind in the United States are socially far above those of any other country; large numbers of them become eminent scholars and musicians, and even their blind workmen enjoy a degree of comfort unknown in England or on the Continent.

The results achieved by the Perkins Institution at Boston, U.S., are particularly instructive. High-class musical training appears to have been commenced there about 13 years ago, previous to which time the results in this respect were far from being satisfactory. The report of 1867 states that music is now taught to all of both sexes whose natural abilities make it probable that, under proper

instruction, they will succeed as organists, teachers of music, or piano tuners, and goes on to say—"The teaching of music and playing is now the largest single field open to the blind as a means of support, and it seems to be growing larger. People are becoming more disposed to employ them; and as they go forth from the school they have more and more ground of hope that they will find opportunities to earn their living in this way." The whole tone of mind among the musical pupils has been changed, for instead of looking forward to the future with fear and anxiety, they now feel a well-grounded confidence in themselves. It seems that in Boston, and in America generally, the blind are able to earn more as teachers of music than as tuners, which is exactly the reverse of the state of things existing in Paris, and may arise either from differences in the condition of the two countries, or from the training for teachers being more thorough at Boston than at Paris; but their experience is identical in one respect, which is, that the blind who have the requisite amount of talent are almost certain to make a good income out of music; but to attain this end they must aim high. It will not do to be equal to the average seeing teacher or tuner; they must be superior; and this involves a good musical notation with first-rate masters, instruments, and appliances, and above all, a determination on the part of managers and teachers to overcome all obstacles.

A few paragraphs from American reports will sufficiently illustrate the enlightened views held in that country in regard to the education of the blind.

"A school for the higher education of the blind should be specially adapted to the condition and wants of the persons to be trained. In it the course of study should be the same as in our best colleges. All instruction should be oral, and the apparatus and modes of illustration be addressed to the touch. It should be supplied with text-books, maps, diagrams, and the like, in raised characters. It should have large collections of models of various kinds, such as weights, measures, tools, machinery, and the like; manikins and models showing the anatomy of plants and animals, as well as their outward form. It should have collections of shells, crystals, minerals, and the like; models and sections showing geological strata; philosophical apparatus adapted to the touch; in short, everything that can be represented by tangible forms.

It would amaze those who have not reflected upon it to know how much can be done in this way. Saunderson, the blind pro-

fessor of mathematics in Cambridge, not only knew ordinary money well, but he was an expert numismatist, and could detect counterfeits in a collection of antique coins better than ordinary persons could do by the sight.

Such an institute should have able professors and teachers, with special aptness for adapting their lessons to the condition of their scholars. It should furnish special facilities for the study of languages, ancient and modern, of mathematics, of pedagogy, and especially of music. It should also be well provided with everything necessary in a good conservatory of music, and have funds for the payment of competent teachers.

It is evident that there are a large number of persons to whom such an institute would be a source of great happiness, and a means of preparation for great usefulness.

A little reflection will show what a great advantage generous culture would be to a blind man, even if he were to be only a musician. Let him be ever so accomplished in his immediate art, he is under great disadvantages as compared with his competitors who can see. But if he has generous culture in other branches of knowledge, he will have advantages which few of them possess, and of course he will be more nearly on a level with them, and more capable of earning a living and enjoying it. Human effort will in such a case be successful in counteracting the principal evil which flows from the infirmity of blindness."

"The careful observer will see a marked difference between a hundred youths in a blind institution and the same number of boys in an ordinary school. This is especially true of the male sex. He will find among the blind a larger proportion of scrofulous, narrow-chested, angular, pallid, and feeble boys, who move sluggishly and soon tire; and a smaller proportion of those full-chested, chubby, rosy, elastic creatures, whom nothing can keep still, and nothing tire out.

Now, if the blind, as a class, have a much smaller *quantum* of life than ordinary persons, it must be either on account of some flaw in the stock whence they sprung, or of some peculiarity in their mode of life, induced by their infirmity, such as bodily inactivity; but it probably results from both causes. At any rate, it is a matter worth considering.

The following tables have been calculated from data furnished by seven American State Institutions for the Blind—namely, those of New York, Ohio, Pennsylvania, Illinois, Missouri, Tennessee, and Massachusetts, and are the results of careful discussion of data, by far the most extensive and trustworthy, it is believed, yet published in any country.

In each of these tables the number of the blind actually surviving in 1859 are compared with the numbers that *should* then be surviving, according to two different Life Tables—first, the Massachusetts Life Table, prepared by Mr Elliott, from the State Census and Registration Returns for the year 1855; and secondly, the English Life Table, prepared by Dr Farr of London, from the returns for the year 1841:—

TABLE I.—Comparing the relative vitality (or ability to resist destructive influences) of the Blind, at diverse ages of life, according to the combined experience of seven American State Institutions for the Blind, with that of the populations of Massachusetts and of England respectively. Calculated by Mr E. B. Elliott, Consulting Actuary, Boston.

Ages on Admission.	Number of Persons Admitted (known whether Surviving or Deceased).	Average Age on Admission.	Average Years elapsed, to middle of 1859.	Number Deceased (before the end of 1859).	Number Surviving (in 1859).	According to Elliott's Massachusetts Life Table.		According to Farr's English Life Table.			
						Number that should be Surviving (in 1859).	Deficiency of Actual Survivors, relative to the Number that should be Surviving.	Number that should be Surviving (in 1859).	Deficiency of Actual Survivors, relative to the Number that should be Surviving.		
										Number.	Per cent.
0-6	14	4.4	19.1	1	13	12.0	-1.0 <sup>3</sup>	13.0	-1.0 <sup>3</sup>	...	
6-10	210	7.7	14.3	39	171	189.2	18.2	9.6	189.8	28.8	9.9
10-14	287	11.5	13.2	52	235	257.2	22.2	8.6	259.5	24.5	9.4
14-18	309	15.5	13.3	38	171	182.0	11.0	6.1	186.6	15.6	8.4
18-22	177	19.3	14.6	50	127	149.6	22.6	15.1	154.0	27.0	17.5
22-26	101	23.2	14.6	19	82	84.8	2.8	3.4	86.9	4.9	5.6
26-30	47	27.4	12.6	10	37	40.3	3.3	8.1	40.8	3.8	9.4
30 and over	38	37.2	12.7	11	27	31.9	4.9	15.4	31.8	4.8	15.2
Age not specified	19	...	12.4	4	15	16.7 <sup>1</sup>	1.7	10.4	17.1 <sup>1</sup>	2.1	12.4
All ages...	1102	15.4	13.8	224	878	963.7	85.7	8.9	978.5	100.5	10.3

*Notes.*—This table may be read thus:—Between the ages of 6 and 10 the number of persons admitted to the above-mentioned institutions, of whom it is known whether they were living in 1859 or had previously deceased, was 210; their average age on admission was 7.7 years; the average period elapsed since admission, and previous to the middle of the year 1859, was 14.3 years; the number of those who died before the end of the year 1859 was 39,—the number surviving in 1859 being 171. The number that should be surviving, according to the Massachusetts Life Table, is 189.2. Hence the number of actual survivors was 18.2 less than the number demanded by the Massachusetts Table, which deficiency is 9.6 per cent. of (189.2) the number so demanded. The number that should be surviving, according to the English Life Table, is 189.8. Hence the number of actual survivors was 18.8 less than the number demanded by the English Table, which deficiency is 9.9 per cent. of (189.8) the number so demanded.

<sup>1</sup> Calculated on the assumption that the average age on admission of the persons whose ages were not specified was the same as the average age of those whose ages were specified, to wit, 15.4 years. <sup>3</sup> Excess.

TABLE II.—Comparing the relative vitality (or ability to resist destructive influences) of the Blind, at different periods after admission, according to the combined experience of seven American State Institutions for the Blind, with that of the population of Massachusetts and England respectively. Calculated by Mr E. B. Elliott, Consulting Actuary, Boston.

Years.	Number of Persons Admitted (Known as Surviving or Deceased).	Number Deceased Previous to the middle of 1859.	Number Surviving in 1859.	Average Age on Admission.	Average Number of Years Elapsed (to middle of 1859).	According to Elliott's Massachusetts Life Table.				According to Farr's English Life Table.			
						Number that should be Surviving (in 1859.)	Deficiency of Actual Survivors, relative to the Number that should Survive.			Number that should be Surviving (in 1859).	Deficiency of Actual Survivors, relative to the Number that should Survive.		
							Number.	Per cent.	Per cent.		Number.	Per cent.	Per cent.
1832	13	4	9	12.7	27	9.7	0.7			10.1	1.1		
1833	49	17	32	16.4	26	26.3	4.3	7.1	12.5	37.6	5.5	10.4	15.6
1834	29	7	22	15.9	25	21.8	0.2 <sup>1</sup>						
1835	26	8	18	17.1	24	19.7	1.7	17.8	12.5	23.6	0.6	90.7	15.6
1836	23	12	21	15.5	23	25.5	4.5						
1837	45	18	27	16.3	22	35.1	8.1	12.3	8.7	26.3	9.3	15.4	11.1
1838	41	12	29	14.9	21	23.6	3.6						
1839	30	12	18	14.5	20	24.2	6.2	6.0	8.7	25.0	7.0	8.4	11.1
1840	37	8	29	16.6	19	29.9	0.9						
1841	47	7	40	14.2	13	39.0	1.0 <sup>1</sup>	8.9	7.6	31.0	2.0	11.0	9.1
1842	56	16	40	16.5	17	46.5	6.5						
1843	70	13	57	12.7	16	60.2	3.2	11.1	4.4	47.9	7.9	6.7	4.5
1844	68	14	54	13.9	15	58.6	4.6						
1845	43	11	32	14.6	14	37.3	5.3	5.0	4.4	59.9	5.9	5.2	4.5
1846	51	9	42	15.3	13	44.6	2.6						
1847	35	8	27	14.2	12	31.2	4.2	6.4	4.4	38.3	6.3	6.7	4.5
1848	43	12	31	16.3	11	39.3	7.3						
1849	60	8	52	16.8	10	54.2	2.2	0.2 <sup>1</sup>	0.2 <sup>1</sup>	31.7	4.7	0.2 <sup>1</sup>	4.5
1850	54	9	45	18.5	9	49.0	4.0						
1851	38	4	34	15.8	8	35.2	1.2	5.0	4.4	40.9	4.9	5.2	4.5
1852	23	1	27	11.5	7	26.7	0.2 <sup>1</sup>						
1853	40	0	40	12.6	6	33.4	1.0 <sup>1</sup>	4.4	4.4	26.7	0.2 <sup>1</sup>	6.7	4.5
1854	30	5	25	14.5	5	23.8	3.8						
1855	24	4	20	15.7	4	23.8	2.8	6.4	4.4	26.9	3.9	6.7	4.5
1856	23	5	18	16.3	3	23.4	4.4						
1857	16	0	16	17.6	2	15.7	0.2 <sup>1</sup>	0.0	0.0	23.0	3.0	0.2 <sup>1</sup>	4.5
1858	23	0	23	16.0	1	22.8	0.2 <sup>1</sup>						
1859	30	0	40	16.2	0	40.0	0.0			40.0	0.0		

Note.—This table may be read thus.—Of the 68 persons admitted to the before-mentioned institutions during the year 1844, 14 died previous to the middle of the year 1859, and 54 were surviving in that year. The average age on admission of the 68 persons was 13.9 years, and the average number of years elapsed between the time of admission and the middle of the year 1859 was about 15 years. According to the Massachusetts Life Table, the number that should be surviving in 1859 was 58.6, showing the number of actual survivors to have been 4.6 less than the number demanded by such table. The deficiency (4.6 + 5.3 + 2.6 = 12.5) of actual survivors relative to the number that should survive of those admitted during the three years 1844, 1845, and 1846, was, according to the Massachusetts Table, 8.9 per cent. of (58.6 + 37.3 + 44.6 = 140.5) the number demanded; and the deficiency of actual survivors relative to the number that should survive of those admitted during the seven years 1839 to 1845 inclusive, was, according to the same life table, 8.7 per cent. of the number demanded. In like manner may be read the results derived from comparison with the English Life Table.

TABLE III.—Summary of the results presented in the two preceding Tables, comparing the relative vitality (or ability to resist destructive influences) of the Blind, at diverse ages of life, and also at diverse periods after admission, according to the combined experience of seven American State Institutions for the Blind, with that of the population of Massachusetts and England respectively. Calculated by Mr E. B. Elliott, Consulting Actuary, Boston.

Deficiency in the number of the Blind that survived in 1859, relative to the number that should then be surviving.

Ages on Admission.	According to the Massachusetts Life Table, Elliott.		Date of Admission (in Periods of Three Years).	Average Years Elapsed (to middle of 1859).	According to the English Life Table, Farr.		Date of Admission (in Periods of Seven Years).	Average Years Elapsed (to middle of 1859).	According to the Massachusetts Life Table, Elliott.		According to the English Life Table, Farr.	
	Per cent.	Per cent.			Per cent.	Per cent.			Per cent.	Per cent.		
	0-6	...			...	1832-34			25.8	7.1	10.4	1832-38
6-10	9.6	9.9	1835-37	22.8	17.8	20.7	1839-45	16.6	8.7	11.1		
10-14	8.6	9.4	1838-40	20.0	12.3	15.4	1846-52	10.2	7.6	9.1		
14-18	6.1	8.4	1841-43	16.9	6.0	8.4	1853-59	3.2	4.4	4.6		
18-22	15.1	17.5	1844-46	14.1	8.9	11.0						
22-26	3.4	5.6	1847-49	10.8	11.1	12.6						
26-30	8.1	9.4	1850-52	8.2	4.4	5.5						
30 and over	15.4	15.2	1853-55	5.1	5.0	5.2						
Age not specified	10.4	12.4	1856-58	2.0	6.4	6.7						
All ages	8.9	10.3										

Note.—This table may be read thus.—Of the number of persons admitted to the above-mentioned institutions, between the ages of 10 and 14, the number that was surviving in 1859 was 8.6 per cent. less according to the Massachusetts Life Table, and 9.4 per cent. less according to the English Life Table, than the number that should then be surviving. Of the number of persons admitted during the three years 1838-40, from which the average time elapsing to the middle of 1859 was 20.0 years, the number that survived in 1859 was 12.3 per cent. less according to the Massachusetts Table, and 15.4 per cent. less according to the English Table, than the number that should then have been surviving. Of the number of persons admitted during the seven years 1839-45, from which the average time elapsing to the middle of 1859 was 16.6 years, the number that survived in 1859 was 8.7 per cent. less according to the Massachusetts Table, and 11.1 per cent. less according to the English Table, than the number that should then have been surviving.

<sup>1</sup> Excess.

According to the first table, it appears that, of the entire 1102 persons admitted whose after-history is known, 878 now survive, whereas the Life Table of Massachusetts calls for about 979 survivors, thereby indicating that the power of the blind, represented by the returns of these institutions, to resist destructive influences is about 9 per cent. (10·8) less than that of the population of all England, and that the number of deaths is from 60 to 80 per cent. greater, according to the tables employed for the comparison, than the number required by such tables.

If we could draw our statistics from the blind as a whole, and not from the favoured few who have been taught in schools, the average duration of life would be much less. We should probably find the average amount of vital force, or power to resist destructive agencies, to be nearly one-fifth less than that of ordinary persons.

It is well known that the blind as a class are happy, contented, and cheerful. There are exceptions, of course, and it is unfortunate that Milton should have been one of them, because his eminence as a poet and scholar makes his example conspicuous, and his words to be taken as the natural language of a class of unfortunates. There have been others more admirable in this respect, for they set forth in their lives and conversation the sublime moral height to which men may attain by grasping courageously the nettle misfortune, and 'plucking thence the flower' happiness." (F. J. C.)

BLOCH, MARK ELIEZER, a German naturalist, born at Ansbach, of very poor Jewish parents, about the year 1730. Having entered the employment of a surgeon at Hamburg, he was enabled by his own exertions to supply the want of early education, and made great progress in the study of anatomy, as well as in the other departments of medical science. After taking his degree as doctor at Frankfort-on-the-Oder he established himself as a physician at Berlin, and found means to collect there a valuable museum of objects from all the three kingdoms of nature, as well as an extensive library. His first work of importance was an essay on the different species of worms found in the bodies of other animals, which gained the prize offered by the Academy of Copenhagen. Many of his papers on different subjects of natural history, comparative anatomy, and physiology, were published in the collections of the various academies of Germany, Holland, and Russia, particularly in that of the Friendly Society of Naturalists at Berlin. But his greatest work was his *Allgemeine Naturgeschichte der Fische* (12 vols., 1782-95), which occupied the labour of a considerable portion of his life, and is considered to have laid the foundations of the science of ichthyology. The publication was encouraged by a large subscription, and it passed rapidly through five editions in German and in French. Bloch made little or no alteration in the systematic arrangement of Artedi and Linneus, although he was disposed to introduce into the classification some modifications depending on the structure of the gills, especially on the presence or absence of a fifth gill, without a bony arch. To the number of genera before established he found it necessary to add nineteen new ones; and he described 176 new species, many of them inhabitants of the remotest parts of the ocean, and by the brilliancy of their colours, or the singularity of their forms, as much objects of popular admiration as of scientific curiosity. In 1797 he paid a visit to Paris, in order to examine the large collections of such subjects of natural history as had been inaccessible to him on the shores of the Baltic; and he returned to Berlin by way of Holland. His health, which had hitherto been unimpaired, began now to decline. He went to Carlsbad for its recovery, but his constitution was exhausted, and he died there on the 6th of August 1799.

**BLOCK MACHINERY.** A block is a case with its contained pulley or pulleys, by means of which weighty objects are hoisted or lowered with facility. There is nothing in the appearance of a block which, to an unpractised eye, would seem to require any stretch of mental ingenuity or of manual dexterity to manufacture. It is a machine apparently so rude in its structure, and so simple in its contrivance, that the name was probably given to it from its

general resemblance to a log of wood, as is obviously the case with a butcher's block, a barber's block, the block of the executioner, &c. Of the two constituent parts of a ship's block, the external *shell* and the internal *sheave*, every carpenter might make the one, and every turner the other; but still block-making is a separate branch of trade, and it is necessary that it should be, for the whole efficiency of the block depends upon the proper proportions being observed between the various parts and the accuracy with which they are adjusted.

Mr Walter Taylor of Southampton took out a patent in the year 1781, to secure the benefit of some improvement he had made in the construction of the sheaves. He also shaped the shells, cut the timber, &c., by machinery driven by water, and carried on so extensive a manufacture of blocks as to be able to contract for nearly the whole supply of blocks and blockmakers' wares required for the use of the Royal Navy. Mr Dunsterville of Plymouth had a similar set of machines wrought by horse-power. Both his blocks and Taylor's were said to be superior to those constructed by the hand, though still deficient in many respects.

It would appear that it was the enormous quantity of blocks consumed in the course of a long protracted war that first called the attention of the Admiralty or Navy Board to the possibility of some reduction being made in the expense of so important an article, and to the imprudence of depending entirely on a single contractor. On these considerations, it seems to have been the intention of Government to introduce, among other improvements in Portsmouth Dockyard about 1801, a set of machines for making blocks there. About this time, too, Mr Brunel had completed a working model of certain machines for constructing, by an improved method, the shells and sheaves of blocks. This model was submitted to the inspection of the lords commissioners of the Admiralty, and it was decided to adopt Mr Brunel's more ingenious machinery.

The advantages to be gained were those common to all cases in which machine work supercedes hand labour, and consisted in the fact that, after the proper sizes of each part had been determined by careful calculation and experience, the machine could be made to observe these sizes with unerring accuracy, and so avoid all variations due to the carelessness or ignorance of the workman; these considerations are in blocks, perhaps more than in most things, of the utmost importance. Another advantage was, that the blocks could be made by Brunel's machinery about 30 per cent cheaper than hand-made blocks had been previously obtained by contract, and the importance of this to the Admiralty in those days, when all ships were so heavily rigged, having no steam to supplement their sail power, will be sufficiently seen when it is stated that the remuneration which Brunel was to receive for his invention was agreed to be the savings of one year, and that these savings were estimated at £16,621; in addition to this he received an allowance of a guinea a day for about six years while engaged on the work, and was paid £1000 for his working model—the total amount paid to Brunel for the invention amounting to about £20,000.

The process may be described as follows:—Pieces of wood are cut roughly to the size of the block, and the first operation is then performed by the *borring-machine*, which bores a hole for the pin, and one, two, or three holes, as the case may be, for single, double, or treble blocks, to receive the first stroke of the mortising chisel; the block is next taken to the *mortising-machine*, where the mortise or mortises for the sheaves are cut; after this, to a *circular saw*, conveniently arranged for cutting off the corners and so preparing the block for the *shaping-machine*, which consists principally of two equal and parallel circular wheels

moving on the same axis, to which one of them is firmly fixed, but on which the other is made to slide; so that these two wheels may be placed at any given distance from each other, and blocks of any size admitted between their two rims or peripheries. For this purpose, both rims are divided into ten equal parts, for the reception of ten blocks, which are firmly fixed between the two wheels. When the double wheel with its ten attached blocks is put in motion, the outer surface of the blocks, or those which are farthest from the centre, strike against the edge of a chisel or gouge fixed in a movable frame, which, being made to slide in a curved direction in the line of the axis, cuts those outward faces of the blocks to their proper curvature. A contrivance is attached to the cutting tool which allows of the curvature being altered in any required way. One side being shaped, the ten blocks are then, by a single operation, each turned one fourth part round, and another side is exposed to the cutting instrument moving in the same direction as before. A third side is then turned outwards, and after that the fourth side, when the whole ten blocks are completely shaped.

The velocity with which the wheels revolve, and the great weight with which their peripheries are loaded, would make it dangerous to the workmen or bystanders, if, by the violence of the centrifugal force, any of the blocks should happen to be thrown off from the rim of the wheels; to prevent the possibility of such an accident, an iron cage or guard is placed between the workman and the machine.

The last operation is performed by the *scoring-machine*, which cuts a groove to receive the binding or strapping of the block. The binding may be of iron or rope, and is very frequently of wire rope.

*The Sheaves.*—The machinery employed for making this part of the block consists of a *circular saw*, by which the log is cut into plates of the thickness required for the sheaves, according to their several diameters. These plates are next carried to a *crown saw*, which bores the central hole, and at the same time reduces them to a perfect circle of the assigned diameter. The sheave, thus shaped, is next brought to the *coaking-machine*, a piece of mechanism not inferior in ingenuity to the shaping machine for the shells. A small cutter, in traversing round the central hole of the sheave, forms a groove for the insertion of the *coak* or *bush*, the shape of which is that of three semicircles, not concentric with each other, nor with the sheave, but each having a centre equally distant from that of the sheave. The manner in which the cutter traverses from the first to the second, and from this to the third semicircle, after finishing each of them, is exceedingly ingenious. So very exact and accurate is this groove cut for the reception of the metal coak, and so uniform in their shape and size are the latter cast, the casting being made not in sand but in iron moulds, that they are invariably found to fit each other so nicely that the tap of a hammer is sufficient to fix the coak in its place. The coaks are cast with small grooves or channels in the inside of their tubes, which serve to retain the oil or grease for the pins.

The sheave, with its coak thus fitted in, is now taken to the *drilling-machine*, which is kept in constant motion. In casting the coaks a mark is left in the centre of each of the three semicircles. This mark is applied by a boy to the point of the moving drill, which speedily goes through the two coaks and the intermediate wood of the sheave. Rivets are put in these holes and clenched by hand. The next operation is performed by the *facing-machine*, which has two cutters, so arranged as to finish the side and groove the edge simultaneously; then the hole for the pin is enlarged to its exact size by the *broaching-machine*. The pins, which form a very important part of the block, are

now made at Portsmouth, not of iron but of *steel*, carefully tempered by special appliances. They are turned by a *self-acting lathe*, and are then reduced to the exact required diameter, and polished in the *pin-polishing machine*. They are also, in this machine, subjected to a proof strain proportional to their sectional area, and thus the strength of the pin is guaranteed.

The blocks are invariably made of English elm, the grain of the wood running lengthways of the block; but in Germany recently, blocks have been made with the grain of the wood running across the block, the reason being that they are less likely to be split by the pressure on the pin of the sheave. The sheaves are made of *lignum vita*.

Three machines of each description for each operation, up to and including the facing-machine, are required. The smallest sized machines will make blocks of from 4 inches to 7 inches in length, the second size from 8 inches to 11 inches, and the largest from 12 inches to 17 inches. Two sizes of the *broaching-machine*, and one *pin-polishing machine*, are sufficient. Blocks larger than 17 inches are made by hand, 26 inches being the largest used in the Royal Navy.

As will be seen from the foregoing account, all machine-made blocks are cut out of a solid piece of wood; whereas hand-made blocks, larger than about 8 inches, are usually made in pieces, filled in at the ends and riveted together. It is questionable whether a block so made is not stronger than one cut out of the solid, as in the latter case the short-grained wood at the ends of the mortises is very liable to give way. In hand-made blocks the brass coak or tail of the sheave is not made of the peculiar shape described for machine-made blocks, but is usually of a circular shape.

The machinery for Portsmouth Dockyard, on Brunel's plans, was made by Mandalay, whose firm—now the very eminent firm of Mandalay Sons and Field—has since supplied block-making machinery to the Spanish, Turkish, and Russian Governments, and also to Chatham Dockyard; the last mentioned, however, has never been used, as the machinery at Portsmouth is capable of supplying all the dockyards, the demand for blocks being much less for the steamships and ironclads than it was formerly for the old sailing ships. The first cost of this machinery is so great that no private firm has yet ventured to set it up, and the whole of the blocks used in merchant ships are made by hand-labour, assisted by a lathe and two or three other simple mechanical contrivances. (T. M.)

**BLOCKADE.** It appears to have been the ancient practice of belligerents at the outset of a war to forbid by proclamation all trade on the part of neutrals with the enemy, and to treat as enemies all those who contravened the proclamation; and neutrals acquiesced tacitly in this practice until the commencement of the 17th century. In the course of that century the ancient practice came into question, as imposing on the commerce of neutrals an inconvenience not justified by any adequate necessity on the part of belligerents, and it has since fallen into desuetude. Belligerents, however, have still maintained, without any question on the part of neutrals, the practice of intercepting supplies going over sea to an enemy under certain conditions, namely, when a belligerent has invested an enemy's port, with the intention of reducing the enemy to surrender from the failure of supplies, and for that object a stoppage of all supplies to such port has become a necessary operation of the war. Any attempt, under such circumstances, on the part of a neutral merchant to introduce supplies into the invested port is a direct interference with the operations of the war, and is inconsistent with neutrality, and it accordingly subjects the offending party to be treated



as an enemy by the belligerent. The question. What constitutes such a belligerent investment of an enemy's port as to create an obligation on the part of neutrals to abstain from attempting to enter it, has been much controverted since the "armed neutrality" of 1780; but all uncertainty as to the principle upon which the decision in each case must proceed, has been put an end to by the declaration of the powers assembled in congress at Paris in 1856, that "Blockades, in order to be binding, must be effective, that is to say, must be maintained by a force sufficient really to prevent access to the enemy's coast." The question of fact will still be a subject for judicial inquiry in each case of capture, whether the conditions under which a blockade has been maintained satisfy the above declaration. If an asserted blockade is maintained in a manner which satisfies the above declaration, there is no limit to the extent of an enemy's coast which may be placed under blockade. There is also a general consent amongst nations that a neutral merchant must have knowledge of a blockade in order to be liable to be treated as an enemy for attempting to break it; but there is not any uniform practice amongst nations on this subject further than that when a blockade has become notorious, the knowledge of it will be presumed against every neutral vessel which attempts to enter the blockaded port. On the other hand, where a blockade is not notorious, it is in accordance with the practice of nations to give some notice of it to neutrals; and this notice may be communicated to them either by actual warning given to each neutral vessel which seeks to cross the line of blockade, or by a constructive warning to all neutrals resulting from an official notification of the blockade on the part of the blockading power to all powers in amity with it. It is a growing practice, if not altogether an established practice, amongst nations which accredit to one another resident envoys, for belligerents to notify diplomatically to the neutral powers the fact that they have placed an enemy's port under blockade; and it is the rule of the prize courts of Great Britain and of the United States of America to hold that, where such an official notification has been made, all the subjects of the neutral powers may be presumed to have knowledge of the blockade. Other powers, amongst which France may be mentioned, have been accustomed to direct their blockading cruisers to give warning of the blockade to each vessel that attempts to cross the line of blockade, and not to capture any vessel unless she attempts to break the blockade after such warning; but the practice of France agrees with the practice of other powers in not giving such warning after a blockade has become notorious. There is, further, a general practice amongst nations to treat the act of sailing with an intention to enter a blockaded port as an unneutral act, which will warrant the capture of a neutral merchant vessel by a belligerent cruiser on any part of the high seas, unless clear evidence is forthcoming from the captured vessel that the intention has been abandoned, or that its execution was contingent on the blockade being raised. After a port has been placed under blockade, egress is prohibited to all neutral vessels, except to such as have entered the port before the blockade was established, if they come out either in ballast or with cargoes taken on board before the commencement of the blockade. No warning is required to affect such vessel with a knowledge of the blockade, and if any such vessel should succeed in passing through the blockading squadron it becomes liable to capture as good prize by a belligerent cruiser on any part of the high seas, until it has reached its port of destination, when the offence is considered to be purged. Under the ancient practice both ship and cargo were confiscable for the breach of a blockade, and even the captain and crew were liable to be treated as enemies. A milder practice is now generally

observed as regards the captain and crew, and a certain equity is administered in the British and American prize courts towards the owners of cargo, where the ship and the cargo do not belong to the same parties, and the owners of the cargo have not any knowledge of the blockade, or have been unable to countermand the shipment of the cargo since the blockade has become known to them. In such cases the cargo is released, although the ship may be rightfully condemned to the captors. (T. T.)

BLOIS, the chief town of the department of Loir-et-Cher in France, is situated in the form of an amphitheatre on the steep slope of a hill on the right bank of the Loire, 35 miles S.W. of Orleans, in 47° 35' N. lat. and 1° 29' E. long. It is united by a bridge of the 17th century with the suburb of Vienne on the other side of the river. The houses of the older part of the town are frequently of antiquarian interest, and the streets, which are in many cases rather stairways than streets, have often a picturesque appearance. The castle is an immense structure built at different periods, part as early as the 13th century. It was the birth-place of Louis XII., and is noted as the scene of the assassination of the duke of Guise and his brother the cardinal by command of Henry III. Among the other remarkable buildings in the town are the Hôtel de Ville, the episcopal palace, now occupied by the prefecture, the cathedral of St Louis (a modern structure), and the churches of St Vincent and St Nicholas. An ancient aqueduct, cut in the solid rock by the Romans, conveys the water of several springs to a reservoir, whence it is distributed to different parts of the town. Blois is the seat of a bishopric founded by Louis XIV., and has a communal college, a normal school, and two diocesan seminaries; an exchange, a hospital, a theatre, a botanical garden, a public library, and an agricultural society. It manufactures gloves, hosiery, hardware, and pottery, and has a considerable trade in wine, brandy, and timber. Population in 1872, 17,475. Though possibly existing under the Roman empire, Blois is first distinctly mentioned by Gregory of Tours in the 6th century, and does not become of much importance till the 9th or 10th, when it forms the chief town of a countship. From that date it appears very frequently in French history. In 1577 and 1588 the States-General were held in the city.

BLOMFIELD, CHARLES JAMES, bishop of London, was born on the 29th May 1786, at Bury-St-Edmund's. He received his first education at his father's school in that town, and was then transferred to the grammar school, where, under the able instruction of the Rev. M. T. Becher, he laid the foundations of an unusually sound and thorough classical scholarship. His career at Trinity College, Cambridge, which he entered in 1804, was brilliant. He gained the Browne medals for Latin and Greek odes, and carried off the Craven scholarship. In 1808 he graduated as third wrangler and first medallist, and in the following year was elected to a fellowship at Trinity College. The first-fruits of his scholarship was an edition of the *Prometheus of Eschylus*, in 1810; this was followed by editions of the *Septem contra Thebas*, *Persea*, *Choephora*, and *Agamemnon*, of Callimachus, and of the fragments of Sappho, Sophron, and Alceus. Blomfield, however, soon ceased to devote himself to mere scholarship. He had been ordained in 1810, and held for a short time the curacy of Chesterford. He was then presented to the rectory of Quarrington, and shortly afterwards to that of Dunton, in Buckinghamshire, where he remained for about five years. In 1817 he was moved to the benefices of Great and Little Chesterford and Tuddenham, and he was in the same year appointed private chaplain to Howley, bishop of London. In 1819 he was nominated by Lord Liverpool to the rich living of St Botolph's, Bishopsgate, and in 1822

he became archdeacon of Colchester. Two years later he was raised to the bishopric of Chester, and in that position began his career of incessant labour for the advancement of the church. Many reforms were needed in the diocese, and the new bishop's energy and ardour succeeded in effecting much, though not without stirring up enemies. In 1828 he was transferred to a wider sphere of activity, being raised to the bishopric of London. This important office he held for eight-and-twenty years, labouring incessantly in a field where unremitting exertion was absolutely necessary. He gave his whole heart to the endeavour to extend the influence and efficiency of the church, and his strenuous activity was not without result. In all political or social movements which concerned the church the bishop took a prominent part. He was noted as being one of the best debaters on the episcopal bench in the House of Lords; he took a leading position in the action for church reform, which culminated in the Ecclesiastical Commission; and he did much for the extension of the colonial episcopate. His health gave way under his unceasing labours, and in 1856 he was permitted to resign his bishopric, retaining Fulham palace as his residence, along with a pension of £6000 per annum. He died at Fulham on the 6th August 1857. In private life Blomfield was warm-hearted, genial, and kindly; he was fond of travelling and of intellectual society, in which he was well qualified to shine. His published works, exclusive of those above mentioned, consist of charges, sermons, lectures, and pamphlets, and of a *Manual of Private and Family Prayers*. He was a frequent contributor to the quarterly reviews, chiefly on classical subjects. An admirable memoir has been published by the bishop's son, *Memoirs of Charles James Blomfield, D.D., Bishop of London, with Selections from his Correspondence*, edited by his son, Alfred Blomfield, M.A., &c., 1863. See also Biber, *Bishop Blomfield and his Times*, 1857.

BLONDEL, DAVID, a Protestant clergyman, distinguished by his proficiency in ecclesiastical and civil history, was born at Chalons-sur-Marne in 1591, and died in 1665. In 1650 he succeeded G. J. Vossius in the professorship of history at Amsterdam. His works were very numerous, and were remarkable even at that period for obscurity of style. The most celebrated of them was the dissertation on Pope Joan, in which he came to the conclusion that the whole story was a mere myth. Considerable Protestant indignation was excited against him on account of this book.

BLOOD. See ANATOMY and PHYSIOLOGY

BLOOD, THOMAS, generally known by the appellation of *Colonel Blood*, was a disbanded officer of the Parliamentary army. Bearing a grudge against the duke of Ormond, who had defeated a conspiracy he engaged in to surprise the castle of Dublin, Blood seized the duke one night in his coach in St James's Street, and carried him off a considerable distance, resolving to hang him at Tyburn; but Ormond struggled for his liberty and was rescued by his servants. Soon after, in 1671, Blood formed the design of carrying off the crown and regalia from the Tower,—an attempt which very nearly proved successful. He had bound and wounded Edwards, the keeper of the jewel-office, and had escaped out of the Tower with his prey; but he was overtaken and seized, together with some of his associates. One of these was known to have been concerned in the attempt upon Ormond, and Blood was immediately concluded to be the ringleader. When questioned, he frankly avowed the enterprise, but refused to discover his accomplices. All these extraordinary circumstances induced Charles II. to seek an interview with him, which not only led to his pardon, but to the king's granting him an estate of £500 a year in Ireland, encouraging his attendance about his person,

and showing him great favour. He died August 21, 1680.

BLOOMFIELD, ROBERT, was born of very humble parents at the village of Honington in Suffolk, in 1766. Losing his father at the age of eleven, he was apprenticed to a farmer, and could only cultivate his literary tastes by perusing such books as he could borrow. Thomson seems to have been his favourite author, and *The Seasons* inspired him with the ambition of being a poet. He came to London, and composed *The Farmer's Boy* in a garret in Bell Alley. The manuscript fell into the hands of Capel Lofft, who encouraged him to print it, and it succeeded so well, that above 26,000 copies of it were sold. His reputation was increased by the appearance of his *Rural Tales, Songs and Ballads, News from the Farm, Wild Flowers, and The Banks of the Wye*. These are of unequal merit; but all breathe a spirit of purity and enthusiasm for the beauties of nature, that place the name of Bloomfield among the most natural and amiable of our pastoral poets. The extensive sale of *The Farmer's Boy* and *Wild Flowers* seems to have done little for the benefit of the poet, who died in poverty at Shefford in Bedfordshire in 1823. His *Remarks in Poetry and Verse*, 2 vols., appeared in 1824, and another edition of his poems in 1866. A selection from his correspondence, edited by Hart, appeared in 1871.

BLOUNT, CHARLES, younger son of Sir Henry Blount, was born at Upper Holloway, April 27, 1654, and died 1693. He gained considerable reputation as a politician and man of letters, but his abilities were not great, and his strength lay in scoffing infidelity. His *Anima Mundi, or an Historical Narration of the Opinions of the Ancients concerning Man's Soul after this Life, according to Unenlightened Nature*, gave great offence; and his translation of Philostratus's *Life of Apollonius Tyannus* was suppressed for the flippancy and impertinence of its attacks on revealed religion. A similar work of his, called *Great is Diana of the Ephesians*, under colour of exposing superstition, struck at revelation. In 1684 he printed a kind of introduction to polite literature, under the title of *Janaa Scientiarum*. His *Just Vindication of Learning and of the Liberty of the Press* (1693) is a shameless plagiarism from the *Areopagitica*. The pamphlet which he sent anonymously to Bohun, the censor, entitled *King William and Queen Mary Conquerors*, set all London in a flame, and completely attained its object, the ruin of Bohun. Indirectly it had a good result in directing attention to the folly of the censorship. After the death of his wife, he proposed to marry her sister, and wrote a letter on that subject with great learning and address; but the archbishop of Canterbury and other divines decided against him, and the lady having therefore refused him, he is said to have shot himself, or, according to Pope's account, to have given himself a mortal wound in the arm. A collected edition of his works was published in 1695 by Gildon, with a life by the editor. See Macaulay, *History*, iv. 352, sqq.; Lechler, *Gen. d. Englisch. Dichtkunst*, 114-127.

BLOW, JOHN, an English musical composer, was born in 1648 at North Collingham in Nottinghamshire. He was educated at the chapel royal, and distinguished himself by his proficiency in music, having composed several anthems at an unusually early age. In 1673 he was made a gentleman of the chapel royal, and in 1685 was named one of the private musicians of James II. In 1687 he became master of the choir of St Paul's Church; in 1695 he was elected organist of St Margaret's, Westminster, and in 1699 composer to the chapel royal. In 1700 he published his *Amphion Anglicus*, a collection of pieces of music for one, two, three, and four voices, with a figured-bass accompaniment. Doctor Burney says that in the *Amphion*,

*Anglicus* "the union of Scottish melody with the English is first conspicuous." Blow died in 1708, and was buried in the north aisle of Westminster Abbey. None of his compositions, most of which are anthems, attain the highest order of merit.

**BLOWPIPE**, a tube for directing a jet of air into a fire or into the flame of a lamp or gas jet, for the purpose of producing a high temperature by complete and rapid combustion. The blowpipe has been in common use from the earliest times for soldering metals and working glass; and since 1733, when Anton Swab first applied it to analysis of mineral substances, it has become a valuable auxiliary to the mineralogist and chemist, in the chemical examination and analysis of minerals. Its application has been variously improved at the hands of Cronstedt, Bergmann, Gahn, Berzelius, Plattner, and others, but more especially by the two last-named chemists.

The simplest and oldest form of blowpipe (still used by gasfitters, jewellers, &c.), is a conical brass tube, about 7 inches in length, curved at the small end into a right angle, and terminating in a small round orifice, which is applied to the flame, while the larger end is applied to the mouth. Where the blast has to be kept up for only a few seconds, this instrument is quite serviceable; but in longer chemical operations inconvenience arises from the condensation of moisture exhaled by the lungs in the tube. Hence many blowpipes are made with a cavity for retaining the moisture. Cronstedt placed a bulb in the centre of his blowpipe. Dr Black's convenient instrument consists of a conical tube of tin plate, with a small brass tube, supporting the nozzle, inserted near the wider end, and a mouth-piece at the narrow end. One of the most suitable forms of blowpipe is that shown in fig. 1. It is Gahn's instru-

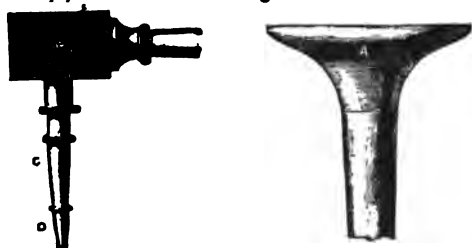

FIG. 1.—Extremities of Gahn's Blowpipe.—ordinary size.

ment as improved by Plattner. The tube A is ground to fit accurately into a socket at the top of the water-trap B, as is also the jet-pipe C. The nozzle D, of platinum, is fitted in the same manner, so that it can be easily removed and replaced while hot; e.g. when it is desired to remove the crust of soot which deposits upon the point when an oil lamp or candle is used. The sizes of orifices recommended by Plattner are 0.4 and 0.5 millim. The trumpet mouthpiece, from the support it gives to the cheeks when inflated, conduces to a more steady and long-continued blast being kept up without fatigue than when the mouthpiece is inserted between the lips. Mr David Forbes has suggested the use of a double jet-pipe in connection with this instrument, so that a large or small orifice may be obtained without stopping the point: but it is doubtful whether the advantage gained is counterbalanced by the extra cost and complication. For the majority of blowpipe workers, there is probably no better instrument than Dr Black's, if provided with a properly-shaped nozzle, if possible of platinum; but where it is much used, the large-sized trumpet-mouthed instrument of Plattner is to be preferred. The instrument should be held with the first and fourth fingers passed round it, and the thumb laid along the side of the tube, the hold being steadied by resting

the elbow on the table. The mode of blowing is peculiar, and requires some practice; an uninterrupted blast is kept up by the muscular action of the cheeks, while the ordinary respiration goes on through the nostrils.

If the flame of a candle or lamp be closely examined, it will be seen to consist of four parts—(a) a deep blue ring at the base, (b) a dark cone in the centre, (c) a luminous portion round this, and (d) an exterior pale blue envelope. The blue ring is formed chiefly by combustion of carbonic oxide. In the central cone the combustible vapours from the wick, though heated, are not burned, atmospheric oxygen not reaching it. In the luminous portion the supply of oxygen is not sufficient for complete combustion; the hydrogen takes up all or most of it, and carbon is precipitated in solid particles and ignited. In the exterior envelope, lastly, the temperature is highest, and combustion most complete,—sufficient oxygen being supplied to convert the carbon and hydrogen into water and carbonic acid.

In blowpipe work only two of these four parts are made use of, viz. the pale envelope, for *oxidation*, and the luminous portion, for *reduction*. To obtain a good *oxidizing flame*, the blowpipe is held with its nozzle inserted in the edge of the flame close over the level of the wick, and blown into gently and evenly. A conical jet is thus produced, consisting of an inner cone, with an outer one commencing near its apex:—the former, corresponding to (a) in the free flame, blue and well defined; the latter, corresponding to (d), pale blue and vague. The heat is greatest just beyond the point of the inner cone, combustion being there most complete. Oxidation is better effected (if a very high temperature be not required) the farther the substance is from the apex of the inner cone, so far as the heat proves sufficient, for the air has thus freer access.

To obtain a good *reducing flame* (in which the combustible matter, very hot, but not yet burned, is disposed to take oxygen from any compound containing it), the nozzle, with smaller orifice, should just touch the flame at a point higher above the wick, and a somewhat weaker current of air should be blown. The flame then appears as a long, narrow, luminous cone,—the end being enveloped by a dimly visible portion of flame corresponding to that which surrounds the free flame, while there is also a dark nucleus about the wick. The substance to be reduced is brought into the luminous portion, where the reducing power is strongest.

The flame of an oil-lamp is the best for blowpipe operations where gas is wanting; candle flame may be used when great heat is not required. The blowpipe lamp of Berzelius, supplied with colza oil, is probably the most suitable. The wick, when in use, should be carefully trimmed and clean, so as to avoid a smoking flame. The general introduction of gas has quite driven out the use of oil-lamps for blowpipe purposes in laboratories.

Various materials are used as supports for substances in the blowpipe flame; the principal are charcoal, platinum, and glass. *Charcoal* is valuable for its infusibility and low conductivity for heat (allowing substances to be strongly heated upon it), and for its powerful reducing agency by the production of carbonic oxide when ignited: so that it is chiefly employed in trying the fusibility of minerals, and in reduction. The best kind of charcoal is that of close-grained pine or alder; it is cut in short prisms, having a flat smooth surface at right angles to the rings of growth. In this a shallow hole is made with a knife or borer, for receiving the substance to be held in the flame. *Platinum* is employed in oxidizing processes, and in fusion of substances with fluxes with a view to try their solubility in them, and note the phenomena of the bead: also in observing the colouring effect of substances on the blowpipe flame (which effect is apt to be somewhat masked

by charcoal). Most commonly it is used in the form of wire, with a small bend or loop at the end. In flux experiments this loop is dipped when ignited in the powdered flux (*e.g.*, borax), then held in a lamp flame till the powder is fused; and the process is repeated, if necessary, till the loop is quite filled with a bead of the flux; to this is now added a little of the substance to be examined. Platinum is also used in the form of foil and of spoons, and for the points of forceps. Metals and easily reducible oxides, sulphides, or chlorides should not be treated upon platinum, as these substances may combine with and damage it. Tubes of hard German glass, 5 to 6 inches long, about  $\frac{1}{4}$  inch diameter, and open at both ends, are useful in the examination of substances containing sulphur, selenium, arsenic, antimony, and tellurium; these, when heated with access of air, evolve characteristic fumes. They are put in the tube near one end (which is held slightly depressed), and subjected to the blowpipe flame. The sublimates often condense on the cooler parts of the tube. Small tubes, closed at one end, are used, where it is required to detect the presence of water, mercury, or other bodies which are volatilised by heat without access of air.

The most important fluxes used in blowpipe analysis are carbonate of sodium, borax, and microcosmic salt. The first (which must be anhydrous and quite free from sulphates) serves chiefly in reducing metallic oxides and sulphides on charcoal, decomposing silicates, determining the presence of sulphur, and discriminating between lime and other earthy bases in minerals. Pure borax, or acid borate of sodium deprived of its water of crystallization by heating, is used for the purpose of dissolving up metallic oxides, when in a state of fusion at a red heat, such fused masses usually having characteristic colours when cold. In some cases the colour and transparency change on cooling. *Microcosmic salt*, or ammonio-phosphate of sodium, is used on platinum wire in the same way as borax; on heating, water and ammonia are given off. The following are some other reagents for certain cases—nitrate of potash, bisulphate of potash, nitrate of cobalt, silica, fluoride of calcium, oxide or oxalate of nickel, protoxide of copper, tin-foil, fine silver, dry chloride of silver, bone ash, and litmus and Brazil-wood paper.

It may be useful here to pass briefly under review a few of the effects obtained in qualitative examinations with the blowpipe. Beginning with the *closed tube*, organic substances may be revealed by the empyreumatic odour given off, and by charring. Mercury condenses on the tube in minute globules. Selenium gives a reddish-brown, tellurium a grey, arsenic a black sublimate. Oxygen is sometimes given off, and will inflame an incandescent splinter of wood when introduced; while ammonia may be detected by red litmus paper, as also the acid or alkaline reaction of any liquid product. In the *open tube*, sulphur and sulphides give off pungent-smelling sulphurous acid gas. Selenium gives a steel-grey deposit, and an odour resembling that of horse radish. Arsenic, antimony, tellurium, yield their respective acids, forming white sublimates. The deposit from arsenic is crystalline, that from the others amorphous. In examination on charcoal, it is useful, in practice, to commence with pure materials and familiarise one's self with their phenomena. Most of the metals fuse in the heat of the blowpipe flame; and in the outer flame they oxidise. The noble metals do not oxidise, but they fuse. The metals platinum, iridium, rhodium, and palladium do not fuse. The incrustations (when such occur) are in each case characteristic, both in aspect and in the effects they give before the blowpipe flame. Among the most common oxides capable of reduction on charcoal alone, in the

inner flame, are those of zinc, silver, lead, copper, bismuth, and antimony. The principal minerals that cannot be so reduced are those containing alkalies and alkaline earths, and the oxides of iron, manganese, and chromium. Many substances give a characteristic colour, when held by platinum forceps in the oxidising flame. For example, arsenic, antimony, lead, colour the flame blue; copper, baryta, zinc, green; lime, lithia, strontia, red; potash, violet. Heated with borax, some bodies give a clear bead, both while hot and cold, except when heated by the intermittent oxidising flame, or the flame of reduction, when the bead becomes opalescent, opaque, or milky white. The alkaline earths, tantalum and titanic acids, yttria and zirconia are examples of this. The oxides of most of the heavy metals give coloured glasses with borax, similar to those obtained by their use in glass or enamel painting. Thus oxide of cobalt gives a showy blue, and oxide of nickel a reddish-brownish colour, both being very characteristic and delicate tests of the presence of these metals. Ferric oxide gives a feeble yellow colour, which is darker while hot; but when the bead so coloured is treated in the reducing flame the iron passes into the state of ferrous oxide, giving an intensely green or nearly black colour. This reaction may be more certainly brought about by touching the bead while melted with a fragment of tin, when the ferric oxide is probably reduced at the expense of the metal. With manganese the reverse effect is produced. A bead containing a considerable quantity of manganeous oxide, such as is produced by a clean reducing flame, is colourless, but when treated in the oxidising flame the showy violet colour of the higher oxide is brought out. This reaction is a very delicate one, and is to be recommended to beginners as a test exercise in blowing a clean flame, the bead being rendered alternately coloured and colourless according as the oxidizing or reducing flame is used. Molybdic acid, which gives a black bead in the reducing, and a clear bead in the oxidising flame, but requires more careful management, was usually recommended by Plattner to his students for this kind of exercise. Copper salts give a green bead in the oxidising and a deep sealing-wax red in the reducing flame. This latter indication is of value in detecting a trace of copper in the presence of iron, which is done by reducing with tin as already described for iron. The effects obtained with beads of microcosmic salt, or as it is more generally called *salt of phosphorus*, are generally similar to those described for borax, but in certain cases it is to be preferred, especially in the detection of silica, which remains undissolved, and titanic acid, which can be made to assume the form of crystals similar to the natural mineral anatase by particular treatment and microscopic examination. Several new phenomena, due to the crystallization of titanic acid and similar bodies, have been described by Gustav Rose.

With carbonate of sodium as flux (a paste of which and the substance to be examined is made with water, and held on charcoal to the flame), three reactions may occur. The substance may fuse with effervescence, or it may be reduced, or the soda may sink into the charcoal, leaving the substance intact on the surface. The first takes place with silica, and with titanic and tungstic acids. The oxides of tungsten, antimony, arsenic, copper, mercury, bismuth, tin, lead, zinc, iron, nickel, and cobalt are reduced. Lead, zinc, antimony, bismuth, cadmium, and tellurium are volatilised partially, and form sublimates on the charcoal. Mercury and arsenic are dissipated as soon as reduced. Silica and titanic acid are the only two substances that produce a clear bead. The bead in which silica is fused is sometimes rendered yellow by the presence of sulphur. Carbonate of soda, with addition of a little nitrate of potash, is very useful for detecting minute quantities of manganese. The fused mass, when clear, has, from the production of man-

<sup>1</sup> In a paper to the Royal Society, Captain Rose points out that it is better to use boric acid and phosphoric acid, instead of borax and microcosmic salts, for various analyses.

ganate of sodium, a fine green colour. (For particulars of the behaviour of different minerals before the blowpipe, see the detailed description in the article MINERALOGY.) Of late years the spectroscope has been successfully used in connection with blowpipe operations, in the detection of certain of the rarer metallic elements.

The blowpipe was first applied in the quantitative determination of metals by Harkort in 1827, and was brought to a high degree of perfection by Plattner. The methods are substantially those adopted in the assay of ores on the large scale in the wind furnace or muffle, thin capsules of clay or cavities in charcoal blocks being substituted for crucibles, and steel basins faced with bone ash, for cupels, in silver and gold assaying. From the small size of the beads obtained, especially when the ores of the precious metals are operated upon, the results are often such as cannot be weighed, and they are then measured by a tangent scale, and the weight computed from the observed diameter. This method, devised by Harkort, gives very accurate results when carefully used, but owing to the difficulty of sampling the minute quantities operated upon so as to represent the bulk of the mineral fairly, the quantitative blowpipe assay has not made much progress. Perhaps the most useful quantitative application is in the determination of nickel and cobalt. This depends upon the fact that when the compounds of these metals, as well as those of copper and iron, with arsenic, are melted in contact with an oxidizing flux, such as borax or salt of phosphorus, iron is first taken up, then cobalt, and next nickel, and finally copper; and as the oxides of these metals give very different colours to the flux, we are enabled by examining the slag to detect the exact moment at which each is removed. For the details of the process the reader is referred to Plattner's work.

Among the various arrangements which have been contrived for supplying air to the blowpipe otherwise than with the mouth, we may select that represented in the annexed figure (2) as one which is generally sufficient for

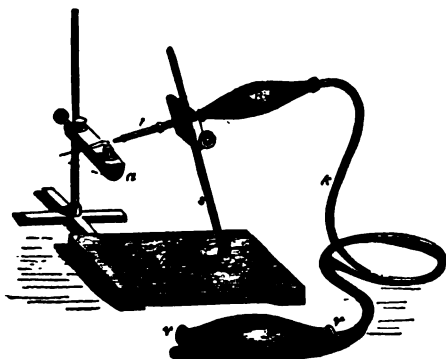

FIG. 2.—Blowpipe with Bellows.

practical purposes. It will be seen that the jet *s* is supported on a slide which can be fixed by screwing in any direction and at any height on the rod *s*, which is jointed on the board *b*. The blast can thus be adjusted variously, according to the position given to the blowpipe lamp *a*, which is of the form devised by Berzelius. The bellows *B*, the tube *t*, and the reservoir *R*, are of vulcanized india-rubber, *v* and *v'* are valves. The bellows being alternately compressed (with hand or foot) and allowed to expand, air is driven into the reservoir, and a fresh supply admitted into the bellows through *v*. After a few trials a constant blast may thus be maintained through the nozzle.

For glass-blowing ordinary coal gas is the best combustible, as the flame can be well controlled by a stop-cock, and requires no trimming. The nature of the apparatus will be understood from fig. 3, which shows the burner in horizontal section.

The tube *ab* is screwed into another tube which is connected with the gas pipe *ef*. *mn* and *op* are two annular disks which support the pipe *ab*; they have a series of openings round their edges, to admit a uniform flow of gas to the narrow annular mouth between the two tubes where it joins the blast. The stop-cock *f* regulates the supply of gas. The wind, supplied by double bellows fixed under the table, is sent through a lead pipe on which brass nozzles of various width can be screwed, opening into *ab*; the finer nozzles being pushed up nearly to the end of this. Elastic tubing may sometimes be used with advantage for the connections. A modified form of the apparatus is suitable for ordinary blowpipe



FIG. 3.—Section of Blowpipe for Glassblowing.

researches of the mineralogist or chemist (see Plattner's work, 4th edition), and the apparatus used in hand-soldering of metals and other operations of the workshop is on the same principle. With suitable trunnions the blowpipe may be made to point in any direction as required.

The soldering lamp of tinner's is an example of the scolipile, an instrument which deserves some notice here. The spirit lamp *a* (fig. 4) is inserted at the bottom of a sheet-iron cylinder *MN*, which is open on one side, as shown. The upper part of the cylinder supports a strong cup of hammered metal, with an opening for spirits at the top (closed by a screw or cock), and a bent tube coming down from its upper part, through a slit in the cylinder to the back of the flame. The weak spirits which are put in the cup are caused to boil by the heat of the lamp, and the vapour, escaping through the bent tube, produces a jet of very hot flame. (The cup is shown separately in fig. 5). Similar advantage is gained by causing air to pass through a quantity of some soluble hydrocarbon before it goes to the nozzle of a blowpipe.



FIG. 4.—Soldering Lamp.



FIG. 5.—Cup of fig. 4.

There are several forms of apparatus in which water-pressure is utilized for supplying a steady blast to the blowpipe. One of these consists of a tin case, with an oblique partition reaching nearly to the bottom. The case is filled nearly three-fourths with water. Air is blown into the compartment which narrows upwards (and with which the nozzle is connected above) by a pipe reaching nearly to the bottom. This air rises through the water and accumulates above it, forcing the water up into the other compartment, which communicates freely with the outer air. The difference of water-level in the two cham-

bers thus sustains a continuous blast through the nozzle. Blowpipes have also been made on the principle of the blowing-machine known as the *trompe*. Again, the blast is sometimes supplied from a chamber in which air is condensed by means of a syringe.

The absorption of heat when an ordinary blast of cold air (with its large proportion of nitrogen) is sent into a flame is considerable; and this has suggested the employment of a hot blast for blowpipe work. Mr T. Fletcher has constructed an apparatus on this principle, which yields a very intense flame, sufficient to fuse platinum wire. The arrangement is represented in fig. 6. It will be observed that the pipe conveying the blast is coiled several times round the gas pipe (for ordinary coal-gas), and that both coil and core are heated by a row of burners placed below. The blast is furnished either with the mouth or with india-rubber bellows.



FIG. 6.—Hot-Blast Blowpipe.

The power of the blowpipe flame may be greatly increased by supplying oxygen in the place of atmospheric air; and a still greater heat is obtained by the combination of pure oxygen and hydrogen. In the latter arrangement, which constitutes the oxyhydrogen blowpipe, it is important that the oxygen and hydrogen be kept in separate reservoirs, and be only allowed to mix at the jet, otherwise explosion may occur through the flame running back through the jet to the reservoir of mixed gases. There are various methods of effecting this, which we do not stop to describe. The blue flame produced gives the most intense heat that is obtainable by artificial means, except by the electric current. Thick platinum wires are melted before it like wax in a candle flame; and earths, such as lime, magnesia, or zirconia, are raised to intense incandescence. For the application of the oxyhydrogen blowpipe to the fusion of the more refractory metals, see PLATINUM.

The literature of the blowpipe is very extensive. The earlier notices of the subject will be found in Berzelius's original work, of which there are English translations by Children, published in 1822, and by J. D. Whitney (of a later edition), published in Boston in 1845. The most complete work, however, is Plattner's *Probirkunst mit dem Löthrohre*, of which there are several editions; the fourth or latest, published since the author's death, has been edited by his pupil and successor, Professor Richter of Freiberg. An English translation, by Professor H. B. Cornwall, has been published in New York. For the use of the blowpipe in determining minerals, the best works are Scheerer's *Löthrohrbuch*, translated by Professor H. B. Blanford, and a *Manual of Determinative Mineralogy, with an Introduction to Blowpipe Analysis*, by Professor G. J. Brush of Yale College. In addition to these works, notices, more or less extensive, will be found in most mineralogical handbooks and works on chemical analysis. (A. B. M.)

BLÜCHER, GERHARD LEBERRECHT VON, field-marshal of the Prussian armies, prince of Wahlstadt in Silesia, was born at Rostock in 1742. In his fourteenth year he entered into the service of Sweden; and in the war between that power and Prussia he was taken prisoner. He afterwards entered into the service of Prussia, in which he became distinguished by his activity; but conceiving himself neglected by the great Frederick, he became a farmer

in Silesia, and by his enterprise and perseverance in fifteen years he acquired an honourable independence. On the accession of Frederick-William II. he was recalled to military service, and replaced as major in his old regiment, the Black Hussars, where he distinguished himself in six general actions against the French, rose to the rank of colonel and major-general in 1793-4, and gained a high reputation by his energy, promptitude, and foresight. He was in a subordinate command in the disastrous battle of Jena in 1802; but he made a masterly retreat with his column to Lübeck, and extorted the praises of his adversaries, who testified on his capitulation that it was caused by "want of provisions and ammunition." He was soon exchanged for General Victor, and was actively employed in Pomerania, at Berlin, and at Königsberg, until the conclusion of the war. When Prussia shook off the French yoke in 1813, he first obtained a separate command. At the head of 60,000 troops, chiefly composed of raw militia, he defeated four French marshals at Katsbach, and rapidly crossing the Elbe, materially contributed to the signal victory of Leipzig. In several severe actions he fought his way to Paris, which he entered on 31st March 1814; and there, it has been stated, but for the intervention of the other allied commanders, he was disposed to make a severe retaliation for the calamities that Prussia had suffered from the armies of France. Blowing up the bridge of Jena across the Seine was said to be one of his contemplated acts. When war again broke out in 1815, the veteran was at the head of the Prussian armies in Belgium, and exhibited his wonted enterprise and activity. But partly owing to his own confidence and temerity, partly to the skilful strategy of his celebrated opponent, he was defeated in the severe battle of Ligny on 16th of June; yet, with his characteristic spirit and energy, Blücher rallied his defeated forces, and appeared on the field of Waterloo on the 18th, just as Wellington had repulsed the last attack of Napoleon on the British position. At that critical moment Blücher was seen emerging from the wood of Frichemont on the French right; and the simultaneous irresistible charge of the British forces converted the retreat of the French into a tumultuous flight. The allied commanders met on the Genappes road, near the farm called Maison du Roi, where the British forces were halted. The pursuit was continued through the night by sixteen fresh Prussian regiments with terrible carnage. The allies soon again entered Paris, where Blücher remained for several months; but the health of the aged commander having declined, he retired to his Silesian residence at Kirblowitz, where he died on the 12th September 1819, aged seventy-seven. The life of Blücher has been written by Varnhagen von Ense (1827), Rauchnick (1836), Bieske (1862), and Scherr (1862).

BLUMENBACH, JOHANN FRIEDRICH, a distinguished physiologist, was born at Gotha on the 11th of May 1752. He studied medicine at Jena, and afterwards at Göttingen, where he took the degree of doctor in 1775. His thesis on that occasion *De Generis Humani Varietate Nativa*, published in quarto, was the germ of those cranio-logical researches to which so many of his subsequent inquiries were directed; and such was the opinion entertained of his acquirements, that he was appointed an adjunct or extraordinary professor of medicine in the following year, and ordinary professor in 1778; soon after which period he began to enrich the pages of the *Medicinisches Bibliothek*, of which he was editor from 1780 to 1794, with various contributions on medicine, physiology, and anatomy. In physiology he was of the school of Haller, and was in the habit of illustrating his theory by a careful comparison of the animal functions of man with those of the lower animals. His reputation was much extended by

the publication of his excellent *Institutiones Physiologicae*, a condensed, well-arranged view of the animal functions, expounded without discussion of minute anatomical details. This work appeared in 1787, and between its first publication and 1821 went through many editions in Germany, where it was the general text-book of the science. It was translated into English in America by Caldwell in 1798, and in London by Elliotson in 1807.

Blumenbach was perhaps still more extensively known by his admirable *Handbuch* of comparative anatomy, of which the German editions were numerous, from its appearance in 1805 to 1824. It was translated into English in 1809 by the eminent surgeon Lawrence, and again, with the latest improvements and editions, by Cousson in 1827. This manual of Blumenbach's, though alighter than the subsequent works of Cuvier, Carus, and others, and not to be compared with such recent expositions as that of Gegenbaur, will always be esteemed for the accuracy of the author's own observations, and his just appreciation of the labours of his predecessors.

One of the most extensive of Blumenbach's works was the *Decas Collectionis sua Craniorum Diversarum Gentium illustrata*, in which accurate though slight delineations of the skulls in his noble collection are given, with brief descriptions of each. It appeared in *fasciculi*, until sixty crania were represented,—exhibiting in a striking manner the peculiarities in form of the skulls of different nations, and justifying the division of the human race into several great varieties or families, of which he enumerated five—the Caucasian or white race, the Mongolian or Tatar, the Malayan or brown race, the Negro or black race, and the American or red race. The classification he thus proposed has been very generally received, and most later schemes have been modifications of it. For these see the article ANTHROPOLOGY, vol. ii. p. 113.

Although the greatest part of Blumenbach's long life was passed at Göttingen, in 1789 he found leisure to visit Switzerland, and gave a curious medical topography of that country in his *Bibliothek*. He was in England in 1788 and 1792. The Prince Regent conferred on him the office of physician to the royal family in Hanover in 1816, and made him knight companion of the Guelphic order in 1821. The Royal Academy of Paris elected him a member in 1831. He died at Göttingen on the 22d of January 1840.

BOA, a name formerly applied to all large Serpents, which, devoid of poison fangs, killed their prey by constriction; but now confined to that section of them occurring in America, the Old World forms being known as Pythons. The true boas are widely distributed throughout tropical America, occurring most abundantly in Guiana and Brazil, where they are found in dry sandy localities, amid forests, on the banks of rivers and lakes, and in the water itself, according to the habits of the various species. They feed chiefly on the smaller quadrupeds, in search of which they often ascend trees, suspending themselves from the branches by the tail, and thus awaiting motionless the approach of their victim. While so hanging they are partly supported by two spine-like hooks, situated one on each side of the vent, which are connected with several small bones concealed beneath the skin and attached to the main skeleton. These bones, terminating thus in an external claw, are characteristic of the family *Boidæ*, and are recognized by anatomists as the rudiments of those which form the hind limbs in all quadrupeds. The size of the boa's prey often seems enormously beyond its apparent capacity for swallowing, a difficulty which disappears on acquaintance with the peculiar structure of the creature's jaws. The bones composing these are not knit together as in Mammals, but are merely connected by ligaments, which

can be distended at pleasure. The mouth of the boa can thus be made to open transversely as well as vertically; and in addition to this the two jaws are not connected directly as in other animals, but by the intervention of a distinct bone, which adds greatly to the extent of its gape. It has also the power of moving one half of the jaw independently of the other, and can thus keep a firm hold of its victim while gradually swallowing it. The boa possesses a double row of solid sharp teeth in the upper jaw, and a single row beneath, all pointing inwards, so that, its prey once caught, it would be well-nigh impossible even for the boa itself to release it. After feeding, boas, like all other reptiles, become inactive, and remain so while the process of digestion is going on, which, in the case of a full meal, may extend over a few weeks, and during this period they are readily killed. All the species are ovoviviparous. The *Jiboya* or *Boa constrictor*—the latter name having been loosely given to all the species—is an inhabitant of the dry and sandy districts of tropical America, and rarely exceeds 20 feet in length. Its food consists chiefly of the agoutis, capybaras, and ant-bears, which abound in those districts. It seeks to avoid man, and is not feared by the inhabitants, who kill it readily with a sharp blow from a stick. The Water-Boa or Anaconda (*Eunectes murinus*) is a much more formidable creature, attaining, it is said, a length of 40 feet, and being thus probably the largest of living serpents. It inhabits the lakes, rivers, and marshes of Brazil and Guiana, and passes a considerable portion of its existence in the water. It is exceedingly voracious, feeding on fishes and on such animals as may come to the banks of the stream to drink, for which it lies in wait with only a small part of its head above the surface of the water. It also occasionally visits the farmyards, carrying off poultry and young cattle, and it has been known to attack man.

BOADICEA, a British queen in the time of the Emperor Nero. She was wife of Prasutagus, king of the Iceni, a people inhabiting the eastern coast of Britain. On his deathbed, 60 A.D., Prasutagus named the emperor heir to his accumulated treasures conjointly with his own two daughters, in expectation of securing thereby Nero's protection for his family and people; but he was no sooner dead than the emperor's officers seized all. Boadicea's opposition to these unjust proceedings was resented with such cruelty, that orders were given that she should be publicly whipped, and her daughters exposed to the brutality of the soldiers. The Britons took up arms, with Boadicea at their head, to shake off the Roman yoke; the colony of Camalodunum or Colchester was taken, and the Romans were massacred wherever they could be found. The whole province of Britain would have been lost to Rome, if Suetonius Paulinus had not hastened from the Isle of Mona, and at the head of 10,000 men engaged the Britons, who are said to have amounted to 230,000. A great battle was fought, which resulted in the complete defeat of the Britons (62 A.D.) Boadicea, who had displayed extraordinary valour, soon after despatched herself by poison. (*Tac. Ann. xiv. Agric. 15-16; Dion Cass. lxxii.*)

BOAR, WILD (*Sus scrofa*), an important species of *Suidæ*, a family of Pachydermatous Mammals, and generally regarded as the original stock of our domestic breeds of swine. In size it is equal to the largest of the domestic kinds, while exceeding them all in strength of body and in ferocity of disposition. It is of a greyish-black colour, covered with short woolly hair, thickly interspersed with coarse stiff bristles, which assume the form of a mane along the spine. The canine teeth are largely developed, forming two pairs of prism-shaped tusks, which thus become formidable weapons. In old age these tusks in the lower jaw gradually curve inwards and upwards over

the snout until they are rendered useless for purposes of attack, when, according to Darwin, they become serviceable for defence in the frequent fights which take place during the rutting season. At the same time, the canines of the upper jaw begin to develop outwards and upwards, and these take the place of the lower ones as offensive weapons. The wild boar is a native of the temperate regions of Europe and Asia, where it inhabits the deepest recesses of forests and marshy grounds. Vambéry, in his recent journey through Central Asia, found them in enormous numbers in the extensive swamps of Turkestan. They appear to have been denizens of British forests at least till the reign of Henry II., after which they are not heard of till the time of Charles I., when an attempt to restock the New Forest with them failed. In the reign of William the Conqueror any one killing a wild boar was liable to have his eyes put out. After reaching maturity the boar becomes a solitary animal, unless during the breeding season, when it seeks the female, and at this time they engage in fierce contests with each other, although these, it is said, seldom lead to fatal results, as they contrive to receive the blows on their tusks, or on the specially tough skin which covers their shoulders. The Indian Wild Boar (*Sus indicus*) is undoubtedly polygamous, and there are several facts which point to a similar habit in the European boar. Both species are nocturnal, issuing from their coverts at twilight in quest of food. This is chiefly of a vegetable nature, consisting of roots which it ploughs up by means of its broad muscular snout and of grain; although they are also known to devour the smaller mammals, birds, and eggs. The female is ordinarily a timid creature, but shows great courage and fierceness in defence of its young. It associates with other females for mutual protection against wolves. The wild boar was for many centuries a favourite beast of chase with the nobility of Europe. It was hunted on foot with the spear,—its great strength, and its ferocity when at bay, rendering the sport alike exciting and dangerous. The gun has now superseded the spear in European boar-hunting, but owing to the comparative scarcity of the boars it is now little practised. In India, however, where these animals abound in the jungles, it is still a favourite sport, the boar being pursued on horseback and speared. The bristles of the boar are much used in the manufacture of brushes.

**BOAT-BUILDING.** See SHIP-BUILDING.

**BOBRUISK**, a town of Russia, in the government of Minak, 110 miles S.E. of that city, in 53° 16' N. lat. and 28° 52' E. long., on the right bank of the Beresina, near the confluence of the Bobruiska, on the high road from Mogileff to Brest-Litovsk. Bobruisk was an unimportant place in 1508, when the Moscovite army, sent by the Emperor Basil against the Polish king Sigismund, advanced towards it. In the 17th century there existed a castle, which was burned down in 1649. When the Minak government was incorporated with Russia, Bobruisk was a small borough; but in 1795 it was raised to the rank of chief town of a department in the Minak government. In the beginning of the reign of Alexander I. there was erected at Bobruisk, by the advice of General Osterman, a fort, which obtained great importance in 1812, and was made equal to the best in Europe by the Emperor Paul I. The fort proper is built on a height exactly at the confluence of the Bobruiska with the Beresina, nearly a mile from the town. On the right bank of the former river is another small fort, called Fort Frederick William, well supported by a line of defences. In 1860 the population of Bobruisk was 23,761, of whom 11,394 were Jews. It has 2 Greek churches, 17 synagogues, a military hospital, and a departmental college. The only industrial establishments are two potteries. On the river near the town there is a har-

bour, by which grain and salt are imported from the southern governments.

**BOCCACCIO, GIOVANNI.** Comparatively little is known of Boccaccio's life, particularly of the earlier portion of it. He was born in 1313, as we know from a letter of Petrarch, in which that poet, who was born in 1304, calls himself the senior of his friend by nine years. The place of his birth is somewhat doubtful,—Florence, Paris, and Certaldo being all mentioned by various writers as his native city. Boccaccio undoubtedly calls himself a Florentine, but this may refer merely to the Florentine citizenship acquired by his grandfather. The claim of Paris has been supported by Baldelli and Tiraboschi, mainly on the ground that his mother was a lady of good family in that city, where she met Boccaccio's father. The balance of evidence is decidedly in favour of Certaldo, a small town or castle in the valley of the Elsa, 20 miles from Florence, where the family had some property, and where the poet spent much of the latter part of his life. He always signed his name Boccaccio da Certaldo, and named that town as his birthplace in his own epitaph. Petrarch calls his friend Certaldese; and Filippo Villani, a contemporary, distinctly says that Boccaccio was born in Certaldo.

Boccaccio, an illegitimate son, as is put beyond dispute by the fact that a special licence had to be obtained when he desired to become a priest, was brought up with tender care by his father, who seems to have been a merchant of respectable rank. His elementary education he received from Giovanni da Strada, an esteemed teacher of grammar in Florence. But at an early age he was apprenticed to an eminent merchant, with whom he remained for six years, a time entirely lost to him, if we may believe his own statement. For from his tenderest years his soul was attached to that "*alma poësis*," which, on his tombstone, he names as the task and study of his life. In one of his works he relates that, in his seventh year, before he had ever seen a book of poetry or learned the rules of metrical composition, he began to write verse in his childish fashion, and earned for himself amongst his friends the name of "the poet." It is uncertain where Boccaccio passed these six years of bondage; most likely he followed his master to various centres of commerce in Italy and France. We know at least that he was in Naples and Paris for some time, and the youthful impressions received in the latter city, as well as the knowledge of the French language acquired there, were of considerable influence on his later career. Yielding at last to his son's immutable aversion to commerce, the elder Boccaccio permitted him to adopt a course of study somewhat more congenial to the literary tastes of the young man. He was sent to a celebrated professor of canon law, at that time an important field of action both to the student and the practical jurist. According to some accounts—far from authentic, it is true—this professor was Cino da Pistoia, the friend of Dante, and himself a celebrated poet and scholar. But, whoever he may have been, Boccaccio's master was unable to inspire his pupil with scientific ardour. "Again," Boccaccio says, "I lost nearly six years. And so nauseous was this study to my mind, that neither the teaching of my master, nor the authority and command of my father, nor yet the exertions and reproof of my friends, could make me take to it, for my love of poetry was invincible."

About 1333 Boccaccio settled for some years at Naples, apparently sent there by his father to resume his mercantile pursuits, the canon law being finally abandoned. The place, it must be confessed, was little adapted to lead to a practical view of life one in whose heart the love of poetry was firmly rooted. The court of King Robert of Anjou at Naples was frequented by many Italian and French men of letters, the great Petrarch amongst the



number. At the latter's public examination in the noble science of poetry by the king, previous to his receiving the laurel crown at Rome, Boccaccio was present,—without, however, making his personal acquaintance at this period. In the atmosphere of this gay court, enlivened and adorned by the wit of men and the beauty of women, Boccaccio lived for several years. We can imagine how the tedious duties of the market and the counting-house became more and more distasteful to his aspiring nature. We are told that finding himself by chance on the supposed grave of Virgil, near Naples, Boccaccio on that sacred spot took the firm resolution of devoting himself for ever to poetry. But perhaps another event, which happened some time after, led quite as much as the first mentioned occurrence to this decisive turning point in his life. On Easter-eve, 1341, in the church of San Lorenzo, Boccaccio saw for the first time the natural daughter of King Robert, Maria, whom he immortalized as Fiammetta in the noblest creation of his muse. Boccaccio's passion on seeing her was instantaneous, and (if we may accept as genuine the confessions contained in one of her lover's works) was returned with equal ardour on the part of the lady. But not till after much delay did she yield to the amorous demands of the poet, in spite of her honour and her duty as the wife of another. All the information we have with regard to Maria or Fiammetta is derived from the works of Boccaccio himself, and owing to several apparently contradictory statements occurring in these works, the very existence of the lady has been doubted by commentators, who seem to forget that, surrounded by the chattering tongues of a court, and watched perhaps by a jealous husband, Boccaccio had all possible reason to give the appearance of fictitious incongruity to the effusions of his real passion. But there seems no more reason to call into question the main features of the story, or even the identity of the person, than there would be in the case of Petrarch's Laura or of Dante's Beatrice. It has been ingeniously pointed out by Baldelli, that the fact of her descent from King Robert being known only to Maria herself, and through her to Boccaccio, the latter was the more at liberty to refer to this circumstance,—the bold expression of the truth serving in this case to increase the mystery with which the poets of the Middle Ages loved, or were obliged, to surround the objects of their praise. From Boccaccio's *Ameto* we learn that Maria's mother was, like his own, a French lady, whose husband, according to Baldelli's ingenious conjecture, was of the noble house of Aquino, and therefore of the same family with the celebrated Thomas Aquinas. Maria died, according to his account, long before her lover, who cherished her memory to the end of his life, as we see from a sonnet written shortly before his death.

The first work of Boccaccio, composed by him at Fiammetta's command, was the prose tale, *Filicopo*, describing the romantic love and adventures of Florio and Biancafiore, a favourite subject with the knightly minstrels of France, Italy, and Germany. The treatment of the story by Boccaccio is not remarkable for originality or beauty, and the narrative is encumbered by classical allusions and allegorical conceits. The style also cannot be held worthy of the future great master of Italian prose. Considering, however, that this prose was in its infancy, and that this was Boccaccio's first attempt at remoulding the unwieldy material at his disposal, it would be unjust to deny that *Filicopo* is a highly interesting work, full of promise and all but articulate power.

Another work, written about the same time by Fiammetta's desire and dedicated to her, is the *Tesside*, an epic poem, and indeed the first heroic epic in the Italian language. The name is chosen somewhat inappropriately, as King Theseus plays a secondary part, and the interest of

the story centres in the two noble knights, Palemone and Arcito, and their wooing of the beautiful Emelia. The *Tesside* is of particular interest to the student of poetry, because it exhibits the first example of the *ottava rima*, a metre which has been adopted by Tasso and Ariosto, and in our own language by Byron in his *Don Juan*. Another link between Boccaccio's epic and our literature is formed by the fact of Chaucer having in the *Knight's Tale* adopted its main features.

Boccaccio's poetry has been severely criticized by his countrymen, and most severely by the author himself. On reading Petrarch's sonnets, Boccaccio resolved in a fit of despair to burn his own attempts, and only the kindly encouragement of his great friend prevented the holocaust. Posterity has justly differed from the author's sweeping self-criticism. It is true, that compared with Dante's grandeur and passion, and with Petrarch's absolute mastery of metre and language, Boccaccio's poetry seems to be somewhat thrown into shade. His verse is occasionally slipshod, and particularly his epic poetry lacks what in modern parlance is called poetic diction,—the quality, that is, which distinguishes the elevated pathos of the recorder of heroic deeds from the easy grace of the mere *conteur*. This latter feature, so charmingly displayed in Boccaccio's prose, has to some extent proved fatal to his verse. At the same time, his narrative is always fluent and interesting, and his lyrical pieces, particularly the poetic interludes in the *Decameron*, abound with charming gallantry, and frequently rise to lyrical pathos.

About the year 1341 Boccaccio returned to Florence by command of his father, who in his old age desired the assistance and company of his son. Florence, at that time disturbed by civil feuds, and the silent gloom of his father's house could not but appear in an unfavourable light to one accustomed to the gay life of the Neapolitan court. But more than all this, Boccaccio regretted the separation from his beloved Fiammetta. The thought of her at once embittered and consoled his loneliness. Three of his works owe their existence to this period. With all of them Fiammetta is connected; of one of them she alone is the subject.

The first work, called *Ameto*, describes the civilizing influence of love, which subdues the ferocious manners of the savage with its gentle power. Fiammetta, although not the heroine of the story, is amongst the nymphs who with their tales of true love soften the mind of the huntsman.

*Ameto* is written in prose alternating with verse, specimens of which form occur in old and middle-Latin writings. It is more probable, however, that Boccaccio adopted it from that sweetest and purest blossom of mediæval French literature, *Aucassin et Nicolette*, which dates from the 13th century, and was undoubtedly known to him. So pleased was Boccaccio with the idea embodied in the character of *Ameto* that he repeated its essential features in the Cimone of his *Decameron* (Day 5th, tale i.)

The second work referred to is a poem in fifty chapters, called *L'amorosa Visione*. It describes a dream in which the poet, guided by a lady, sees the heroes and lovers of ancient and mediæval times. Boccaccio evidently has tried to imitate the celebrated *Triompf* of Petrarch, but without much success. There is little organic development in the poem, which reads like the *catalogue raisonné* of a picture gallery; but it is remarkable from another point of view. It is perhaps the most astounding instance in literature of ingenuity wasted on trifles; even Edgar Poe, had he known Boccaccio's puzzle, must have confessed himself surpassed. For the whole of the *Amorosa Visione* is nothing but an acrostic on a gigantic scale. The poem

is written, like the *Divina Commedia*, in *terza rima*, and the initial letters of all the triplets throughout the work compose three poems of considerable length, in the first of which the whole is dedicated to Boccaccio's lady-love, this time under her real name of Maria. In addition to this, the initial letters of the first, third, fifth, seventh, and ninth lines of the dedicatory poem form the name of Maria; so that here we have the acrostic in the second degree. No wonder that thus entrammelled the poet's thought begins to flag and his language to halt.

The third important work written by Boccaccio during his stay at Florence, or soon after his return to Naples, is called *L'amorosa Fiammetta*; and although written in prose, it contains more real poetry than the elaborate production just referred to. It purports to be Fiammetta's complaint after her lover, following the call of filial duty, had deserted her. Bitterly she deplores her fate, and upbraids her lover with coldness and want of devotion. Jealous fears add to her torture, not altogether unfounded, if we believe the commentators' assertion that the heroine of *Ameto* is in reality the beautiful Lucia, a Florentine lady loved by Boccaccio. Sadly Fiammetta recalls the moments of former bliss, the first meeting, the stolen embrace. Her narrative is indeed our chief source of information for the incidents of this strange love-story. It has been thought unlikely, and indeed impossible, that Boccaccio should thus have become the mouthpiece of a real lady's real passion for himself; but there seems nothing incongruous in the supposition that after a happy reunion the poet should have heard with satisfaction, and surrounded with the halo of ideal art, the story of his lady's sufferings. Moreover, the language is too full of individual intensity to make the conjecture of an entirely fictitious love affair intrinsically probable. *L'amorosa Fiammetta* is a monody of passion sustained even to the verge of dulness, but strikingly real, and therefore artistically valuable.

By the intercession of an influential friend, Boccaccio at last obtained (in 1344) his father's permission to return to Naples, where in the meantime Giovanna, grand-daughter of King Robert, had succeeded to the crown. Being young and beautiful, fond of poetry and of the praise of poets, she received Boccaccio with all the distinction due to his literary fame. For many years she remained his faithful friend, and the poet returned her favour with grateful devotion. Even when the charge of having instigated, or at least connived at, the murder of her husband was but too clearly proved against her, Boccaccio was amongst the few who stood by her, and undertook the hopeless task of clearing her name from the dreadful stain. It was by her desire, no less than by that of Fiammetta, that he composed (between 1344 and 1350) most of the stories of his *Decameron*, which afterwards were collected and placed in the mouths of the Florentine ladies and gentlemen. During this time he also composed the *Filistrato*, a narrative poem, the chief interest of which, for the English reader, lies in its connection with Chaucer. With a boldness pardonable only in men of genius, the great English poet has adopted the main features of the plot, and has literally translated parts of Boccaccio's work, without so much as mentioning the name of his Italian source.<sup>1</sup>

In 1350 Boccaccio returned to Florence, owing to the death of his father, who had made him guardian to his younger brother Jacopo. He was received with great dis-

tingtion, and entered the service of the Republic, being at various times sent on important missions to the margrave of Brandenburg, and to the courts of several popes, both in Avignon and Rome. Boccaccio boasts of the friendly terms on which he had been with the great potentates of Europe, the emperor and pope amongst the number. But he was never a politician in the sense that Dante and Petrarch were. As a man of the world he enjoyed the society of the great, but his interest in the internal commotions of the Florentine state seems to have been very slight. Besides, he never liked Florence, and the expressions used by him regarding his fellow-citizens betray anything but patriotic prejudice. In a Latin elogue he applies to them the term "Batrachos" (frog), by which, he adds parenthetically—*Ego intelligo Florentinorum morem; loquacissimi enim sumus, verum in rebus bellicis nihil valeamus*. The only important result of Boccaccio's diplomatic career was his intimacy with Petrarch. The first acquaintance of these two great men dates from the year 1350, when Boccaccio, then just returned to Florence, did all in his power to make the great poet's short stay in that city agreeable. When in the following year the Florentines were anxious to draw men of great reputation to their newly-founded university, it was again Boccaccio who insisted on the claims of Petrarch to the most distinguished position. He himself accepted the mission of inviting his friend to Florence, and of announcing to Petrarch at the same time that the forfeited estates of his family had been restored to him. In this manner an intimate friendship grew up between them to be parted only by death. Common interests and common literary pursuits were the natural basis of their friendship, and both occupy prominent positions in the early history of that great intellectual revival commonly called *Renaissance*.

During the 14th century the study of ancient literature was at a low ebb in Italy. The interest of the lay world was engrossed by political struggles, and the treasures of classical history and poetry were at the mercy of monks, too lazy or too ignorant to use, or even to preserve them. Boccaccio himself told that, on asking to see the library of the celebrated monastery of Monte Casino, he was shown into a dusty room without a door to it. Many of the valuable manuscripts were mutilated; and his guide told him that the monks were in the habit of tearing leaves from the codices to turn them into psalters for children, or amulets for women at the price of four or five *soldi* a piece. Boccaccio did all in his power to remove by word and example this barbarous indifference. He bought or copied with his own hand numerous valuable manuscripts, and an old writer remarks that if Boccaccio had been a professional copyist, the amount of his work might astonish us. His zealous endeavours for the revival of the all but forgotten Greek language in western Europe are well known. The most celebrated Italian scholars about the beginning of the 15th century were unable to read the Greek characters. Boccaccio deplored the ignorance of his age. He took lessons from Leone Pilato, a learned adventurer of the period, who had lived a long time in Thessaly and, although born in Calabria, pretended to be a Greek. By Boccaccio's advice Leone Pilato was appointed professor of Greek language and literature in the university of Florence, a position which he held for several years, not without great and lasting benefit for the revival of classical learning. Boccaccio was justly proud of having been intimately connected with the foundation of the first chair of Greek in Italy. But he did not forget, in his admiration of classic literature, the great poets of his own country. He never tires in his praise of the sublime Dante, whose works he copied with his own hand. He conjures his friend Petrarch to study the great Florentine, and to defend himself against

<sup>1</sup> Among the publications of the Chaucer Society for 1873 the reader will find a careful analysis of *Filistrato*, together with an English translation of the lines partly or entirely embodied in Chaucer's poem, by Mr. W. M. Rossetti. The parallel between the treatment of the same story by two poets, both great in their individual spheres, and both in a manner representative of their national types of literature, is of engaging interest.

the charges of wilful ignorance and envy brought against him. A life of Dante, and the commentaries on the first 16 cantos of the *Inferno*, bear witness to Boccaccio's learning and enthusiasm.

In the chronological enumeration of our author's writings we now come to his most important work, the *Decameron*, a collection of one hundred stories, published in their combined form in 1353, although mostly written at an earlier date. This work marks in a certain sense the rise of Italian prose. It is true that Dante's *Vita Nuova* was written before, but its involved sentences, founded essentially on Latin constructions, cannot be compared with the infinite suppleness and precision of Boccaccio's prose. The *Cento Novelle Antiche*, on the other hand, which also precedes the *Decameron* in date, can hardly be said to be written in artistic language according to definite rules of grammar and style. Boccaccio for the first time speaks a new idiom, flexible and tender, like the character of the nation, and capable of rendering all the shades of feeling, from the coarse laugh of cynicism to the sigh of hopeless love. It is by the name of "Father of Italian Prose" that Boccaccio ought to be chiefly remembered.

Like most progressive movements in art and literature, Boccaccio's remoulding of Italian prose may be described as a "return to nature." It is indeed the nature of the Italian people itself which has become articulate in the *Decameron*; here we find southern grace and elegance, together with that unveiled *naïveté* of impulse which is so striking and so amiable a quality of the Italian character. The undesirable complement of the last-mentioned feature, a coarseness and indecency of conception and expression hardly comprehensible to the northern mind, also appears in the *Decameron*, particularly where the life and conversation of the lower classes are the subject of the story. At the same time, these descriptions of low life are so admirable, and the character of popular parlance rendered with such humour, as often to make the frown of moral disgust give way to a smile.

It is not surprising that a style so concise and yet so pliable, so typical and yet so individual, as that of Boccaccio was of enormous influence on the further progress of a prose in a manner created by it. This influence has indeed prevailed down to the present time, to an extent beneficial upon the whole, although frequently fatal to the development of individual writers. Novelists like Giovanni Fiorentino or Franco Sacchetti are completely under the sway of their great model; and Boccaccio's influence may be discerned equally in the plastic fullness of Machiavelli and in the pointed satire of Aretino. Without touching upon the individual merits of Lasca, Bandello, and other novelists of the *cinquecento*, it may be asserted that none of them created a style independent of their great predecessor. One cannot indeed but acquiesce in the authoritative utterance of the Accademia della Crusca, which holds up the *Decameron* as the standard and model of Italian prose. Even the Della Cruscan writers themselves have been unable to deprive the language wholly of the fresh spontaneity of Boccaccio's manner, which in modern literature we again admire in Manzoni's *Promessi sposi*.

A detailed analysis of a work so well known as the *Decameron* would be unnecessary. The description of the plague of Florence preceding the stories is universally acknowledged to be a masterpiece of epic grandeur and vividness. It ranks with the paintings of similar calamities by Thucydides, Defoe, and Manzoni. Like Defoe, Boccaccio had to draw largely on hearsay and his own imagination, it being almost certain that in 1348 he was at Naples, and therefore no eye-witness of the scenes he describes. The stories themselves, a hundred in number, range from the highest pathos to the coarsest licentiousness.

A creation like the patient Griselda, which international literature owes to Boccaccio, ought to atone for much that is morally and artistically objectionable in the *Decameron*. It may be said on this head, that his age and his country were not only deeply immoral, but in addition exceedingly outspoken. Moreover, his sources were anything but pure. Most of his improper stories are either anecdotes from real life, or they are taken from the *fabliaux* of mediæval French poets. On comparing the latter class of stories (about one-fifth of the whole *Decameron*) with their French originals, one finds that Boccaccio has never added to, but has sometimes toned down the revolting ingredients. Notwithstanding this, it cannot be denied that the artistic value of the *Decameron* is greatly impaired by descriptions and expressions, the intentional licentiousness of which is but imperfectly veiled by an attempt at humour.

Boccaccio has been accused of plagiarism, particularly by French critics, who correctly state that the subjects of many stories in the *Decameron* are borrowed from their literature. A similar objection might be raised against Chaucer, Shakespeare, Goethe (in *Faust*), and indeed most of the master minds of all nations. Power of invention is not the only nor even the chief criterion of a great poet. He takes his subjects indiscriminately from his own fancy, or from the consciousness of his and other nations. Stories float about in the air, known to all yet realized by few; the poet gathers their *disejuncta membra* into an organic whole, and this he inspires and calls into life with the breath of his genius. It is in this sense that Boccaccio is the creator of those innumerable beautiful types and stories, which have since become household words amongst civilized nations. No author can equal him in these contributions to the store of international literature. There are indeed few great poets who have not in some way become indebted to the inexhaustible treasure of Boccaccio's creativeness. One of the greatest masterpieces of German literature, Lessing's *Nathan the Wise*, contains a story from Boccaccio (*Decameron*, Day 1st, tale iii.), and the list of English poets who have drawn from the same source comprises amongst many others the names of Chaucer, Lydgate, Dryden, Keats, and Tennyson.

For ten years Boccaccio continued to reside in Florence, leaving the city only occasionally on diplomatic missions or on visits to his friends. His fame in the meantime began to spread far and wide, and his *Decameron*, in particular, was devoured by the fashionable ladies and gentlemen of the age. About 1360 he seems to have retired from the turbulent scenes of Florence to his native Certaldo, the secluded charms of which he describes with rapture. In the following year took place that strange turning-point in Boccaccio's career, which is generally described as his conversion. It seems that a Carthusian monk came to him while at Certaldo charged with a posthumous message from another monk of the same order, to the effect that if Boccaccio did not at once abandon his godless ways in life and literature his death would ensue after a short time. It is also mentioned that the revelation to the friar on his deathbed of a secret known only to Boccaccio gave additional import to this alarming information. Boccaccio's impressionable nature was deeply moved. His life had been far from virtuous; in his writings he had frequently sinned against the rules of morality, and worse still, he had attacked with bitter satire the institutions and servants of holy mother church. Terrified by the approach of immediate death, he resolved to sell his library, abandon literature, and devote the remainder of his life to penance and religious exercise. To this effect he wrote to Petrarch. We possess the poet's answer; it is a masterpiece of writing, and what is more, a proof of tenderest friendship. The message of the monk Petrarch is evidently inclined

to treat simply as pious fraud, without however actually committing himself to that opinion. "No monk is required to tell thee of the shortness and precariousness of human life. Of the advice received accept what is good; abandon worldly cares, conquer thy passions, and reform thy soul and life of degraded habits. But do not give up the studies which are the true food of a healthy mind." Boccaccio seems to have acted on this valuable advice. His later works, although written in Latin and scientific in character, are by no means of a religious kind. It seems, however, that his entering the church in 1362 is connected with the events just related.

In 1363 Boccaccio went on a visit to Naples to the seneschal Acciajuoli (the same Florentine who had in 1344 persuaded the elder Boccaccio to permit his son's return to Naples), who commissioned him to write the story of his deeds of valour. On his arrival, however, the poet was treated with shameful neglect, and revenged himself by denying the possibility of relating any valorous deeds for want of their existence. This declaration, it must be confessed, came somewhat late, but it was provoked by a silly attack on the poet himself by one of the seneschal's indiscreet friends.

During the next ten years Boccaccio led an unsettled life, residing chiefly at Florence or Certaldo, but frequently leaving his home on visits to Petrarch and other friends, and on various diplomatic errands in the service of the Republic. He seems to have been poor, having spent large sums in the purchase of books, but his independent spirit rejected the numerous splendid offers of hospitality made to him by friends and admirers. During this period he wrote four important Latin works—*De Genealogia Deorum libri XV.*, a compendium of mythological knowledge full of deep learning; *De Montium, Silvarum, Lacuum, et Marium nominibus libri*, a treatise on ancient geography; and two historical books—*De Casibus Virorum et Feminarum Illustratum libri IX.*, interesting to the English reader as the original of John Lydgate's *Fall of Princes*; and *De Claris Mulieribus*. To the list of his works ought to be added *Il Ninfale Fiescolano*, a beautiful love-story in verse, and *Il Corbaccio ossia Il Laberinto d'Amore*, a coarse satire on a Florentine widow who had jilted the poet, written about 1358, not to mention many eclogues in Latin and miscellaneous *Rime* in Italian (the latter collected by his biographer Count Baldelli in 1803).

In 1373 we find Boccaccio again settled at Certaldo. Here he was attacked by a terrible disease which brought him to the verge of death, and from the consequences of which he never quite recovered. But sickness could not subdue his intellectual vigour. When the Florentines established a chair for the explanation of the *Divina Commedia* in their university, and offered it to Boccaccio, the senescent poet at once undertook the arduous duty. He delivered his first lecture on the 23d of October 1373. The commentary on part of the *Inferno*, already alluded to, bears witness of his unabated power of intellect. In 1374 the news of the loss of his dearest friend Petrarch reached Boccaccio, and from this blow he may be said to have never recovered. Almost his dying efforts were devoted to the memory of his friend; urgently he entreated Petrarch's son-in-law to arrange the publication of the deceased poet's Latin epic *Africa*, a work of which the author had been far more proud than of his immortal sonnets to Laura.

In his last will Boccaccio left his library to his father confessor, and after his decease to the convent of Santo Spirito in Florence. His small property he bequeathed to his brother Jacopo. His own natural children had died before him. He himself died on the 21st of December 1375 at Certaldo, and was buried in the church of SS.

Jacopo e Filippo of that town. On his tombstone was engraved the epitaph composed by himself shortly before his death. It is calm and dignified, worthy indeed of a great life with a great purpose. These are the lines:—

"Hæc sub mole jacent cineres ac ossa Joannis;  
Mens sedet ante Deum, meritis ornata laborum  
Mortalis vita. Genitor Boccacœus illi;  
Patria Certaldum; studium fuit alma potest."

A complete edition of Boccaccio's Italian writings, in 17 vols., has been published by Moutier (Florence, 1834). The life of Boccaccio has been written by Tiraboschi, Mazzuchelli, Count Baldelli (*Vita di Boccaccio*, Florence, 1806), and others. The first printed edition of the *Decameron* is without date, place, or printer's name; but it is believed to belong to the year 1469 or 1470, and to have been printed at Florence. Besides this, Baldelli mentions eleven editions during the 15th century. The entire number of editions by far exceeds a hundred. A curious expurgated edition, authorised by the Pope, appeared at Florence, 1573. Here, however, the grossest indecencies remain, the chief alteration being the change of the improper personages from priests and monks into laymen. The best old edition is that of Florence, 1527. Of modern reprints, that by Forloni (Florence, 1857) deserves mention. Manni has written a *Storia del Decameron* (1742), and a German scholar, M. Landau, has published (Vienna, 1869) a valuable investigation of the sources of the *Decameron*. An interesting English translation of the work appeared in 1824, under the title *The Model of Mirth, Wit, Eloquence, and Conversation*. (F. H.)

BOCCALINI, TRAJANO, an Italian satirist, was born at Loretto in 1556. The son of an architect, he himself adopted that profession, and it appears that he commenced late in life to apply to literary pursuits. Pursuing his studies at Rome, he had the honour of teaching Bentivoglio, and acquired the friendship of the cardinals Gaetano and Borghesi, as well as of other distinguished personages. By their influence he obtained various posts, and was even appointed by Gregory XIII. governor of Benevento in the states of the church. Here, however, he seems to have acted imprudently, and he was soon recalled to Rome, where he shortly afterwards composed his most important work, the *Ragguagli di Parmaso*, in which Apollo is represented as receiving the complaints of all who present themselves, and distributing justice according to the merits of each particular case. The book is full of light and fantastic satire on the actions and writings of his eminent contemporaries, and some of its happier hits are among the hackneyed felicities of literature. To escape, it is said, from the hostility of those whom his shafts had wounded, he returned to Venice, and there, according to the register in the parochial church of Sta Maria Formosa, died of colic, accompanied with fever, on the 16th of November 1613. It was asserted, indeed, by contemporary writers that he had been beaten to death with sand-bags by a band of Spanish bravadoes, but the story seems without foundation. At the same time, it is evident from the *Pietra del Paragone*, which appeared after his death in 1615, that whatever the feelings of the Spaniards towards him, he cherished against them feelings of the bitterest hostility. The only Government, indeed, which is exempt from his attacks is that of Venice, a city for which he seems to have had a special affection. The *Ragguagli*, which was first printed in 1612, has frequently been republished; but its popularity seems exceeded by that of the *Pietra*, which has been translated into French, German, English, and Latin. The English translator was Henry earl of Monmouth, and the title of his version, *The Politicks Touchstone*, London, 1674. Another posthumous publication of Boccacalini was his *Commentarii sopra Cornelio Tacito*, Geneva, 1669, which ought rather to be called observations than commentaries, and has not done much for his fame. Many of his manuscripts are preserved still unprinted in various Italian libraries. (See Mazzuchelli's *Scrittori d'Italia*.)

**BOCHART, SAMUEL**, a learned writer of the 17th century, specially distinguished as an Oriental scholar, was born at Rouen in Normandy, May 30, 1599. He was many years pastor of a Protestant church at Caen, and became tutor to Wentworth Dillon, earl of Roscommon, author of the *Essay on Translated Verse*. While at Caen he particularly distinguished himself by his public disputations with Father Veron, a Jesuit, and celebrated as a polemic. The dispute was held in the castle of Caen, in the presence of a great number of Catholics and Protestants, the duke of Longueville being among the former. In 1646 Bochart published his *Phaleg* and *Chanaan*, which are the titles of the two parts of his *Geographia Sacra*. His *Hierozoicon*, which treats of the sacred animals of Scripture, was printed at London in 1675. In 1652, Christina, queen of Sweden, invited him to Stockholm, whither he repaired, accompanied by Huet. On his return to Caen he resumed his duties as a minister of the gospel, married, and was received into the academy of that city. Bochart was a man of profound erudition; he possessed a thorough knowledge of the principal Oriental languages, including Hebrew, Syriac, Chaldaic, and Arabic; and such was his zeal for extending his acquirements, that at an advanced age he wished to learn Æthiopia. He was remarkable for modesty and candour; but so absorbed was he in his favourite study, that he saw Phœnician, and nothing but Phœnician, in everything, even in the words of the Celtic, and hence the prodigious number of chimerical etymologies which swarm in his works. He died at Caen, May 16, 1667. A complete edition of his works was published at Leyden, under the title of *Sam. Bochart Opera Omnia: hoc est; Phaleg, Chanaan, seu Geographia Sacra, et Hierozoicon, seu de Animalibus sacris Sacra Scriptura, et Dissertationes Variæ*, 1675, 2 vols. folio; 1692, 1712, 3 vols. folio.

**BOCHENIA**, the chief town of a district in Austrian Galicia, on the River Raba or Uswica, a tributary of the Vistula. It is built principally of wood, and has a gymnasium, a hospital, and various public offices. Its importance is mainly due to its extensive salt mines, entrance to which is obtained by a shaft in the very heart of the town. The excavations, carried on at different levels, have completely undermined the whole area of the place, which was greatly damaged by a subsidence of the ground in 1843, occasioned by heavy floods. About 290,000 cwts. of salt are obtained annually. Population in 1869, 7480.

**BOCHUM**, the chief town of a circle in the Prussian province of Westphalia and government of Arnsberg, on the railway between Duisburg and Dortmund. It is a busy industrial town, with manufactures of cassimeres, woollen cloth, carpets, and hardware of various descriptions. About 27,000 hand coffee-mills are turned out annually. There is an extensive steel factory in the hands of a company; coal-mines are worked, and coke is manufactured; and a considerable trade is carried on in grain. Population in 1871, 21,192.

**BODE, JOHANN ELERT**, a celebrated German astronomer, born January 19, 1747, at Hamburg, where his father kept a commercial academy. From his earliest years he was devoted to the mathematical sciences, especially astronomy. In the garret of his father's house, with the aid of a telescope constructed by himself, he eagerly made observations of the heavens; and at eighteen years of age he had acquired so great a knowledge of astronomy, that when Dr Reimarus visited his father, young Bode was found occupied in calculating an eclipse of the sun. This incident was the means of introducing him to the notice of Professor Bäsch, who at once afforded him every facility for prosecuting his labours with success. Shortly afterwards Bode

gave the first public proof of his knowledge by a short work on the solar eclipse of August 5, 1766; and this was followed by his *Anleitung zur Kenntniss des gestirnten Himmels*, an elementary treatise on astronomy, which was eminently successful, and has since gone through numerous editions. In 1772, being called to Berlin by Frederic II., he was made astronomer to the Academy of Sciences, and afterwards a member of that institution. The well-known periodical work entitled *Astronomische Jahrbücher*, which is continued to the present day, was commenced by Bode in 1774; but that on which his fame chiefly rests is the *Uranographia*, published in 1801, in which the industrious author has given observations of 17,240 stars, or 12,000 more than are to be found in any older charts. This veteran observer, who may justly be said to have been the first to diffuse a general taste for astronomy in Germany, died at Berlin, Nov. 23, 1826. For the curious empirical law which bears Bode's name, see *ASTRONOMY*, vol. ii. p. 806.

**BODIN, JEAN**, one of the ablest political thinkers in France during the 16th century, was born at Angers in 1530. He studied law at Toulouse, and, after taking his degree, lectured there for some time on jurisprudence. Thence he proceeded to Paris, and began to practise at the bar. His want of success is said to have been the reason of his applying himself to literature; but this we may reasonably doubt, as he was only twenty-five years of age when he published his first work, a translation of Oppian's *Cynægeticon* into Latin verse, with a commentary. Almost immediately on its publication the celebrated scholar, Turnebus, complained that some of his emendations had been appropriated without acknowledgment. A discourse on public instruction, *Oratio de Instituenda in Republica Juventute*, which Bodin had delivered at Toulouse, was printed in 1559, and his *Methodus ad Facilem Historiarum Cognitionem* appeared in 1566. The latter is a work of considerable interest and value. It has, indeed, no title to the high honour which M. Baudrillart assigns to it of having laid the foundation of the philosophy of history; but it contains several thoughts of essential importance to that philosophy, as, for example, those relative to the nature of history, to progress and law in history, and to historical causation. Two years later Bodin published a work in refutation of the views of M. de Malestroict, who maintained that there had been no rise of prices in France during the three preceding centuries. The *Responsio ad Paradoxa Malestroicti* not only completely established the contrary, but for the first time explained in a nearly satisfactory manner the revolution of prices which took place in the 16th century, pointing out not only its primary but most of its secondary causes with remarkable perspicacity. This tract, the *Discours sur les causes de l'estimation cherté qui est aujourd'hui en France* (1574), and the disquisition on public revenues in the sixth book of the *Republic*, undoubtedly entitle Bodin to a distinguished position among the earlier cultivators of political economy. His learning, genial disposition, and conversational powers recommended him to the favour of Henry III. and of his brother, the duke of Alençon. The former appointed him to the office of king's attorney at Leon in 1576. This was the most eventful year of his life, being that in which he married, performed his most brilliant service to his country, and completed his greatest literary work. Elected by the Tiers Etat of Vermandois to represent it in the states-general of Blois, he contended with great skill and boldness in extremely difficult circumstances for freedom of conscience, justice, and peace. The nobility and clergy favoured the League, and urged the king to force his subjects to abjure Protestantism and profess the Catholic religion. When Bodin found he could not prevent this

resolution being carried, he contrived to get inserted in the petition drawn up by the states the clause "without war," which practically rendered all its other clauses nugatory. While he thus resisted the clergy and nobility and their dependents, he opposed the demand of the king to be allowed to alienate the public lands and royal demesnes, and had influence sufficient to get it refused, although the chief deputies had been won over to assent to it. This lost him the favour of the king, who wanted money on any terms. His *magnum opus*—*Les six livres de la République* (Paris, 1576)—passed through various editions in its author's lifetime, that of 1683 having as an appendix *L'apologie de René Herpin* (Bodin himself). In 1586 he issued a Latin version, for the use chiefly of English students of law and politics. It is the first elaborate attempt in modern times to construct a system of political science. "From the time," says Sir William Hamilton, "when Aristotle wrote his eight books of *Politics*, until the time when Montesquieu wrote his thirty-one books on *The Spirit of Laws*, the six books of the *Republic* of Bodinus is the ablest and most remarkable treatise extant on the philosophy of government and legislation; and even until the present day these three authors stand out as the great political triumvirate." Bodin was, of course, greatly indebted to Aristotle for his knowledge of the working of political causes, but he made use of what his illustrious predecessor taught him in no servile way, and added much from his own reflections, his large acquaintance with history, and his vivid personal experience. The *Republic* is a work of which it is quite impossible to give a brief account, and as there have been many lengthened summaries of it, it may suffice to say that those to be found in Hallam's *Lit. of Europe* (vol. ii. 1st ed.), Heron's *History of Jurisprudence*, Lermnier's *Introduction à l'Histoire du Droit*, and Bluntschli's *Geschichte des Staatsrechts*, give a good general view of its character, while that in Professor Baudrillart's *J. Bodin et son Temps* is so exceedingly careful and excellent that scarcely a thought of any value in the original has escaped being indicated. With all his breadth and liberality of mind Bodin was an exceedingly credulous believer in witchcraft, the virtues of numbers, and the power of the stars, and in 1580 he published the *Demonomanie des Sorciers*, a work which is a most humbling evidence that even the greatest men may not be exempt from the most irrational prejudices of their age. Although he was himself regarded by most of his contemporaries as a sceptic, and by some as an atheist, he denounced all who dared to doubt of sorcery, and zealously urged the burning of witches and wizards. It might, perhaps, have gone hard with himself if his counsel had been strictly followed, as he confessed to have had from his thirty-seventh year a friendly demon who, if properly invoked, touched his right ear when he purposed doing what was wrong, and his left when he meditated doing good. To the duke of Alençon Bodin owed several important preferments. In 1581 he accompanied his patron as secretary when that prince came over to England to seek the hand of Queen Elizabeth. Here he had the pleasure of finding that the *Republic* was studied at London and Cambridge, although in a barbarous Latin translation. This was what determined him to translate his work into Latin himself. The latter part of Bodin's life was spent at Leon, the inhabitants of which he is said to have persuaded to declare for the League in 1589, and for Henry IV. five years afterwards. He died of the plague in that city in 1596, and was buried in the church of the Carmelites. In the year during which he died there appeared his *Universale Naturæ Theatrum*, which was translated into French by Fongerolles in the following year. He left behind him a very famous MS., the *Colloquium Neptaplomeræ de abditis rerum sublimium arcansis*, which

was published for the first time in a complete form by Noack in 1857, although it had been previously studied by others, e.g., Grotius, Huet, Ménage, Dieckmann, &c. It is composed in the form of a conversation between seven learned men—a Jew, a Mahometan, a Lutheran, a Zwinglian, a Roman Catholic, an Epicurean, and a Theist. The conclusion to which they are represented as coming is that they will live together in charity and toleration, and cease from further disputation as to religion.

*Authorities.*—The works of Bodin above mentioned; H. Baudrillart, *J. Bodin et son Temps* (Paris, 1858); N. Planchevaul, *Études sur Jean Bodin* (Angers, 1858); and Thierry, *History of the Three Estates* (Engl. Transl.). As to the political philosophy of Bodin, see the works of Hallam, Heron, Lermnier, and Bluntschli, already indicated; as to his political economy, Kantz, *Geschichte der National-Ökonomik*, ii. 269-271; as to his ethical teaching, A. Desjardins, *Les Moralistes Français des Sécolaux Sixiècle*, ch. v.; and as to his historical views, Flint's *Philosophy of History in Europe*, i. 66-76. (R. F.)

**BODLEY, SIR THOMAS**, founder of the Bodleian library at Oxford, was born at Exeter in 1544. When he was about twelve years of age, his father, John Bodley, being obliged to leave the kingdom on account of his Protestant principles, settled with his family at Geneva, and continued there till the death of Queen Mary. In that university, then in its infancy, young Bodley studied under several eminent professors. On the accession of Queen Elizabeth he returned with his father to England, and was soon after entered of Magdalen College, Oxford. In 1563 he took the degree of bachelor of arts, and the year following was admitted a fellow of Merton College. In 1565 he read a Greek lecture in the hall of that college, took the degree of master of arts the year after, and read natural philosophy in the public schools. In 1569 he was one of the proctors of the university, and for some time after officiated as public orator. Quitting Oxford in 1576, he made the tour of Europe; and on returning to his college after four years' absence he applied himself to historical and political studies. He became gentleman-usher to Queen Elizabeth; and in 1585 he married Anne Ball, a widow lady of considerable fortune, whose father, named Carew, was of Bristol. He was soon after sent as ambassador to the king of Denmark, and to several German princes. He was next despatched on a secret mission to France; and in 1588 he went as ambassador to the United Provinces. On his return to England in 1597, finding his preferment obstructed by the jarring interests of Burleigh and Essex, he retired from court, and could never afterwards be prevailed on to accept of any public employment. He now began the foundation of the Bodleian library; and soon after the accession of King James I. he received the honour of knighthood. He died at his house in London, January 28, 1612, and was buried in the choir of Merton College chapel, where a monument of black and white marble was erected to him, on which stands his effigy in a scholar's gown, surrounded with books. Sir Thomas wrote his own life to the year 1609, which, with the first draught of the Statutes and his Letters, has been published from the originals in the Bodleian library, by Hearn, under the title of *Reliquiæ Bodleianæ, or Authentic Remains of Sir Thomas Bodley*, London, 1793, 8vo. For a particular account of the Bodleian library, see **LIBRARIES**.

**BODMIN**, a parliamentary and municipal borough and market-town of England, in the county of Cornwall, 235 miles from London, and 30 from Plymouth by rail. It is situated between two hills, and consists of one narrow but well-paved street, about a mile in length. The church of St Petrock, which formerly belonged to the monastery of that name, is a spacious building dating from 1472; and the town-hall consists partly of remains of the convent of the Grey Friars. A lunatic asylum, erected in 1866, the

county jail, rebuilt in 1859, and a market-house of recent date, are among the chief buildings. The principal manufacture is shoes. Four annual fairs for cattle and horses are held in the town, and at St Lawrence, one mile to the S.W., there is a fair in October for cattle and sheep.

Bodmin returned two members to Parliament from the time of Edward I. till 1868, when its representation was reduced to one member. The assizes and quarter-sessions are held in the town, and it is one of the polling-places for the east division of the county.



Arms of Bodmin.

Bodmin or, as the name appears in charters, *Bosmana* or *Bod-minian*, grew up in the neighbourhood of a monastic building, which is said to have been founded as early as 926. At the time of the Conquest it was a flourishing town, but fell into decay at the Reformation, and only recovered its prosperity in the course of last century. In 1498 the Cornish insurrection was originated by the people of Bodmin, who again, in the reign of Edward VI., expressed their discontent at the change of religion by resorting to arms. Population of municipal borough in 1871, 4672, and of parliamentary borough, 6758.

**BODONI, GIAMBATTISTA**, superintendent of the royal press at Parma, chief printer to his Catholic Majesty, member of various academies in Italy, and knight of several orders, was born in 1740, at Saluzzo in Piedmont, where his father owned a printing establishment. While yet a boy he began to engrave on wood. He at length went to Rome, and there became a compositor for the press of the Propaganda. He made himself acquainted with the Oriental languages, and thus was enabled to render essential service to the Propaganda press, by restoring and accurately distributing the types of several Oriental alphabets which had fallen into disorder. The Infante Don Ferdinand having established at Parma, about 1760, a printing-house on the model of those in Paris, Madrid, and Turin, Bodoni was placed at the head of this establishment, which he soon rendered the first of the kind in Europe. The beauty of his typography, &c., leaves nothing further to be desired; but the intrinsic value of his editions is seldom equal to their outward splendour. His Homer, however, is a truly magnificent work; and, indeed, his Greek letters are faultless imitations of the best Greek manuscript. His editions of the Greek, Latin, Italian, and French classics are all highly prized for their typographical elegance, and some of them are not less remarkable for their accuracy. Bodoni died at Padua in 1813, aged 73. In 1818 a magnificent work appeared in two volumes quarto, entitled *Manuale Typografico*, containing specimens of the vast collection of types which had belonged to this celebrated typographer. See De Lama, *Vita del Cavaliere Giambattista Bodoni*, 1816, 2 vols.

**BOEOE**, or **BOYCA**, **Βοιωτός**, a distinguished Scottish historian, was born at Dundee, about the year 1465, being descended of a family which for several generations had possessed the barony of Panbride or Balbride. The orthography of his surname is extremely fluctuating; it is to be found under the various modifications of Boece, Boeth, Boeis, Boys, Boyse, Boyes, Boyis, Boiss, and Boyca. He received his early education at Dundee, and completed his course of study in the university of Paris, where he took the degree of B.D. He was appointed a professor of philosophy in the college of Montaigu; and in this seminary he became intimately acquainted with Erasmus,

who in two epistles has testified his esteem for Boece's character (*Erasmii Opera*, tom. i. tom. iii. col. 1784, edit. Clerici). In his academical station he had already distinguished himself when King's College was founded at Aberdeen by the munificence of William Elphinstone, bishop of the diocese. The Papal bull for the erection of a university had been obtained in the year 1494, but the buildings were not sufficiently advanced, nor did the lectures commence, till about the year 1500. It was not without some degree of hesitation that he consented to quit the lettered society of Paris, and to become principal of this new college; but having at length accepted the conditions, he proceeded to Aberdeen, and experienced a kind reception from the canons of the cathedral, several of whom he has commemorated as men of learning. It was a part of his duty as principal to read lectures on divinity. The common branches of science and literature were taught with zeal and success; and the prosperity of the institution was greatly promoted by the influence of Boece.

The emoluments of his office were not such as appear very dazzling to modern eyes. "Boethius, as president of the university," says Dr Johnson, "enjoyed a revenue of forty Scottish marks, about two pounds four shillings and sixpence of sterling money. In the present age of trade and taxes, it is difficult even for the imagination so to raise the value of money, or so to diminish the demands of life, as to suppose four and forty shillings a year an honourable stipend; yet it was probably equal not only to the needs but to the rank of Boethius. The wealth of England was undoubtedly to that of Scotland more than five to one, and it is known that Henry the Eighth, among whose faults avarice was never reckoned, granted to Roger Ascham, as a reward of his learning, a pension of ten pounds a year." But it is necessary to recollect that this was not the only preferment which Boece enjoyed: he was not only principal of King's College, but was likewise a canon of Aberdeen, and rector of Tyrie in the same county. Under the date of July 14, 1527, we find a "grant to Maister Hector" of an annual pension of £50, to be paid by the sheriff of Aberdeen out of the king's casualties; and on the 26th of July 1529 was issued a "precept for a letter to Mr Hector Boys, professor of theology, of a pension of £50 Scots yearly, until the king promote him to a benefice of 100 marks Scots of yearly value; the said pension to be paid him by the customers of Aberdeen." In 1533 and 1534, one-half of his pension was, however, paid by the king's treasurer, and the other half by the comptroller; and as no payment subsequent to that of Whitsuntide 1534 has been traced in the treasurer's accounts, he is supposed to have obtained his benefice soon after that period.

His earliest publication, the lives of the bishops of Aberdeen, appeared under the following title—*Epicoporum Murthlacensium et Aberdonensium per Hectorem Boetium Vita. Impressa sunt hac prelo Ascensiano ad Idus Maias anno Salutis, M.D.XXII.*, 4to. This little volume, which is of great rarity, was reprinted for the members of the Bannatyne Club—*Hectoris Boetii Murthlacensium et Aberdonensium Epicoporum Vita sterum in lucem edita*, Edin., 1826, 4to. Of this diocese the seat was originally at Murthlack, or Mortlach, in the county of Banff, but it was afterwards transferred to Aberdeen. His notices of the early prelates are necessarily brief and unsatisfactory, and the most interesting portion of the book is that which relates to his liberal patron Bishop Elphinstone, of whose private history and public services he has given a circumstantial detail, which occupies nearly one-third of the volume. Here we likewise find an account of the foundation and constitution of the college, together with some notices of its earliest members. His more famous work, the *History of Scotland*, was published after an interval of

five years:—*Scolorum Historia a prima gentis origine cum aliarum et rerum et gentium illustratione non vulgari: promissa epistola nuncupatoria, tabellisque amplissimis, et non parviter Isagoge, qua ab hujus tergo explicabitur diffusius. Quae omnia impressa quidem sunt Iodoci Badii Ascensii typis et opera; impensis autem nobiliss et praedocti viri Hectoris Boethii Deidonani, a quo sunt et condita et edita, fol.* The title and colophon have no date, but the commendatory epistle by Alexander Lyon, precentor of the cathedral of Elgin, bears the 15th of March 1527. This edition contains seventeen books. Another edition, containing the eighteenth book and a fragment of the nineteenth, was published by Ferrerius, who has added an appendix of thirty five pages; Paris, 1574, fol. Though published at Paris, the latter edition appears from the colophon to have been printed at Lausanne.

The composition of Boece's history displays much ability; and if the style does not always reach the standard of ancient purity, it displays a certain vein of elegance which generally renders it attractive. The author's love of his native country, and his anxiety to emblazon the heroic deeds of his countrymen, are conspicuous in every part of the work; nor must we leave unnoticed those aspirations after political freedom, by which he was honourably distinguished at a period when the human mind was so generally chained to the earth by the most slavish maxims of submission. It may be recorded as commendation instead of reproach, that his principles of polity have been represented as no better than those of Buchanan. Boece's imagination was, however, stronger than his judgment: of the extent of the historian's credulity, his narrative exhibits many unequivocal proofs; and if this circumstance admits of a sufficient excuse from the common propensity of the age in which he lived, his work presents strong indications of another fault, for which it is not so easy to find an apology. According to Bishop Lloyd, he put Fordun's tales "into the form of an history, and pieced them out with a very good invention, that part in which he chiefly excelled." (Lloyd's *Historical Account of Church Government in Great Britain and Ireland*, pref.) He professes to have obtained from the monastery of Icolmkill, through the good offices of the earl of Argyll, and his brother the treasurer, certain original historians of Scotland, and among the rest Veremundus and Campbell, of whose writings not a single vestige is now to be found. In his dedication to the king, he is pleased to state that Veremundus, a Spaniard by birth, was archdeacon of St Andrews, and that he wrote in Latin a history of Scotland from the origin of the nation to the reign of Malcolm III., to whom he inscribed his work. According to Bishop Stillingfleet, whose opinion has been adopted by many other writers, these historians never existed except in Boece's fertile imagination. His propensity to the marvellous was at an early period exposed in the following tetrastich of Leland:—

"Hectoris historici tot quot mendacia scripsit,  
Si vis ut numerus, lector amice, tibi,  
Me jubeat etiam fictus numerare marinos,  
Et liquidi stellas connumerare poli."

Lhuyd, who attacked him in different works, spoke of his fabrications with unsparing severity, nor did he experience much better treatment from Stanihurst, an Irish writer of considerable reputation. Of his merits as an historian a very unfavourable estimate was formed by Lord Hailes and Mr Pinkerton. But in the opinion of Wallace, a learned lawyer, his "elegant style and correct composition, not to add beautiful genius and fine fancy, are conclusive proofs that his understanding could not be inaccurate." And, as Maitland, the editor of Bellenden's translation of Boece's history, has remarked, "in forming a final estimate of the literary character of Boece, we must bear

in mind that, when scholar-craft in this country at least was rare, he was a scholar, and contributed, by reviving ancient learning, to dispel the gloom of the Middle Ages; and that, while the history of his country existed only in the rude page of the chroniclers who preceded him, or in the fading records of oral tradition, he embodied it in narrative so interesting and language so beautiful, as to be worthy of a more refined age."

Boece's *History of Scotland* was translated into the Scottish language by John Bellenden, archdeacon of Moray and canon of Ross. While the learned archdeacon was engaged in translating the work into prose, another individual was engaged in the more formidable task of translating it into verse. A copy of this metrical version, containing about 70,000 lines, is preserved in the library of the University of Cambridge; a leaf seems to be wanting at the beginning, and the manuscript has suffered some other mutilations. The name of the versifier does not appear, nor has it been ascertained from any other document; but we learn from the prologue that his labours, like those of Bellenden, were intended for the benefit of the young monarch. From the concluding lines, it is ascertained that he began his task in April 1531, and concluded it in September 1535. His verses are not distinguished by any considerable degree of energy or elegance, and the writer is chiefly to be commended for his perseverance.

In 1528, soon after the publication of his history, Boece took the degree of D.D. at Aberdeen; and on this occasion the magistrates voted him a present of a tun of wine when the new wines should arrive, or, according to his option, the sum of £20 to purchase a new bonnet. He appears to have survived till the year 1536; for on the 22d of November in that year, the king presented John Garden to the rectory of Tyrie, vacant by the death of "Mr Hector Boisia." He died at Aberdeen, and, according to the most probable conjecture, he had then attained, or at least approached, the age of seventy.

BOECKH, AUGUST, one of the greatest scholars that Germany has produced in modern times, was born in Karlsruhe, November 24, 1785. He was sent to the gymnasium of his native city, and remained there until he left for the University of Halle. There he devoted himself to the study of theology, as his intention was to enter the church. He had the privilege of listening to the lectures of Schleiermacher and other eminent theologians; but at this time in Halle F. Wolf was exercising a spell over the young men and creating an enthusiasm for classical studies. August Boeckh felt the spell, passed from theology to philology, and became the greatest of all Wolf's scholars. At Easter of 1806 he went to Berlin to study in the seminary for secondary teachers, conducted by Gedike; but the disturbances which then agitated the country sent him home. In the summer of 1807 he came out as privat-docent in the University of Heidelberg, and in the autumn of the same year he was appointed a professor extraordinary. Two years after (1809) he was nominated ordinary professor. In 1811 he removed to Berlin, having been appointed professor of eloquence and ancient literature in the university newly established there. Here he remained till his death, which took place August 3, 1867. He was elected a member of the Academy of Sciences of Berlin in 1814, and for a long time acted as its secretary. Many of the speeches contained in his *Kleine Schriften* were delivered in this latter capacity.

Boeckh worked out the ideas of Wolf in regard to philology, and illustrated them by his practice. Discarding the old notion that philology lay in a minute acquaintance with words and the exercise of the critical art, he believed it to be the entire knowledge of antiquity, historical and philosophical (*esse cum universa antiquitatis cognitionem*



*historiam et philosophiam*). He divides philology into five parts: first, an inquiry into public acts, with a knowledge of times and places, into civil institutions, and also into law; second, an inquiry into private affairs; third, an exhibition of the religions and arts of the ancient nations; fourth, a history of all their moral and physical speculations and beliefs, and of their literatures; and fifth, a complete explanation of the language. These ideas in regard to philology Boeckh gave out in a Latin oration delivered in 1822 (*Gesammelte Kleine Schriften*, vol. i. p. 104). He repeats them in somewhat different language in the speech which he delivered at the opening of the congress of German philologists in 1850. He there defines philology to be the historical construction of the entire life,—therefore, of all forms of culture and all the productions of a people in its practical and spiritual tendencies. He allows that such a work is too great for any one man; but the very infinity of subjects is the stimulus to the pursuit of truth, and men strive because they have not attained (vol. ii. p. 189). Even before Boeckh had published anything on this subject, his oral expositions had become widely spread, and were much discussed. (Lübker, "De Partitione Philologiae," *Gesammelte Schriften zur Philologie und Pädagogik*, vol. i. p. 8.) Freund gives the following account of Boeckh's division of philology:—

"Boeckh distinguishes two chief parts of philological discipline—a formal and a material part. To the formal part belong only interpretation and criticism; to the material all the other disciplines, even grammar. More particularly the material part embraces—I. the practical life; II. the theoretical life of the ancients. I. The practical, again, falls into the two divisions of—1. Public life, including (1) political history, (2) political antiquities, (3) chronology, and (4) geography; 2. Private life, which is considered as (1) external life, in agriculture, commerce, trades, domestic economy, and metrology; (2) internal life, including marriage, education, slaves, &c. II. Theoretical life is divided into two parts—1. The life in which the thought of man is presented externally through a symbol—worship, plastic art, music, *Orchestik*; 2. Life in which the thought remains pure within the mind—science. In the case of the last (1) the contents, and (2) the form of acquisition are distinguished. The contents lie originally in mythology, out of which philosophy developed itself, and out of philosophy came the other sciences, which are partly physical, including mathematics, and partly ethical. The form of knowledge is language, and it must be considered first in itself, in its inner structure through grammar, and then in its formation and application to the various artistic forms which the history of literature has to exhibit" (*Wie studirt man Philologie*, p. 29).

From 1806 till the time of his death, Boeckh's literary activity was unceasing. His principal works were—(1.) An edition of Pindar, the first volume of which (1811) contains the text of the Epinician odes; a treatise *De Metris Pindari*, in three books; and *Nota Critica*: the second (1819) contains the *Scholiaz*; and part ii. of volume ii. (1821) contains a Latin translation, a commentary, the fragments, and indices. It is the most complete edition of Pindar that we have. But it was especially the treatise *De Metris Pindari* in the first volume which placed Boeckh in the first rank of scholars. This treatise forms an epoch in the treatment of Greek metres. In it the author threw aside all attempts to determine the Greek metres by mere subjective standards, pointing out at the same time the close connection between the music and the poetry of the Greeks. He investigated minutely the nature of Greek music as far as it can be ascertained, as well as all the details regarding Greek musical instruments; and he explained the statements of the ancient Greek writers on

rhythm. In this manner he laid the foundation for a new treatment of Greek metres. (2.) *Die Staatseinkhaltung der Athener*, 2 vols., Berlin, 1817 (2d improved edition, Berlin, 1851), translated into English by Sir George Cornewall Lewis, 2 vols., Lond., 1828. Boeckh shows in this work an imperfect acquaintance with the principles of the modern science of political economy. The book might have been written by an ancient Greek. But this imperfection does not much impair its great value and extraordinary merits. Boeckh has in it investigated a subject of peculiar difficulty with profound learning. He has amassed information from the whole range of Greek literature, he has carefully apprised the value of the information given, and he shows throughout every portion of it rare critical ability and insight. Similar and supplementary to his work on the political economy of Athens, was his *Urbunden über das Seewesen des Attischen Staats*, Berlin, 1840. Allied to it also was his work *Metrologische Untersuchungen über Gewichte, Münzfuss, und Maasse des Alterthums*, Berlin, 1838. (3.) His third great work arose out of his second. In regard to the taxes and revenue of the Athenian state he derived a great deal of his most trustworthy information from inscriptions, and many of these inscriptions are given in his book. It was natural, therefore, that when the Berlin Academy of Sciences projected the plan of a *Corpus Inscriptionum Græcarum*, Boeckh should be chosen as the principal editor. This great work (1825–1859) is in four volumes, the last being incomplete. Boeckh's resources as a scholar have full scope in the treatment of these inscriptions, and though a new edition is now necessary and has been begun, Boeckh's explanations of them will form the basis of all subsequent commentaries.

These were Boeckh's great works; but his activity was continually digressing into widely different fields. He has gained for himself a foremost position amongst investigators into ancient chronology, and his name will occupy a parallel place with those of Ideler and Mommsen. His principal work on this subject was called *Zur Geschichte der Mondzyklen der Hellenen*, Leipzig, 1855; but another, *Epigraphisch-chronologische Studien*, 1856, and several papers which he published in the *Transactions of the Berlin Academy*, throw light on the subject. Boeckh also occupied himself with philosophy. One of his earliest papers was on the Platonic doctrine of the world (*De Platonicæ corporis mundani fabrica*, 1809), and *De Plat. System. celestium globorum et de vera indole astronomia Philolaia*, 1810. In opposition to Gruppe he denied that Plato affirmed the diurnal rotation of the earth, *Untersuchungen über das kosmische System des Platon*, Berlin, 1852, and when in opposition to him Grote published his opinions on the subjects (Plato and the Rotation of the Earth) Boeckh was ready with his reply. Another of his earlier papers, and one frequently referred to, was *Commentatio Academica de similitudine quæ Platoni cum Xenophonte intercessionis fertur* (1811).

Boeckh did not do much in the way of editing the classics. We have already noticed his edition of Pindar. He also published an edition of the *Antigone* of Sophocles, with a poetical translation. (*Antigone, Griechisch und Deutsch: Nebst Abhandlungen über diese Tragödie in Gassen und über Einzelne Stellen derselben*, Berlin, 1843). He also collected and arranged the fragments ascribed to Philolaus (Berlin, 1819), and endeavoured to show that they were genuine. The force of his arguments in this direction has, however, been recently weakened by Schaarschmidt, and the genuineness of the fragments is open to grave doubt.

The smaller writings of Boeckh began to be collected in his lifetime. Three of the volumes were published before his death, and four after (*Gesammelte Kleine Schriften*, 7 vols., 1859–1873). The first two consist of orations

delivered in the university or academy of Berlin, or on public occasions. The third, fourth, fifth, and sixth contain his contributions to the *Transactions of the Berlin Academy*, and the seventh contains his critiques. The first two are valuable among other excellences from an educational point of view, and contain an exposition of many sound educational principles. In them Boeckh shows himself a man of wide heart, interested in the most diverse forms of investigation, an ardent patriot, and a lover of justice and truth.

(J. D.)

BOEHME, JAKOB (1575-1624), a mystical writer, whose surname (of which Fechner gives eight German varieties) appears in English literature as Beem, Behmont, &c., and notably in the form BREHMEN, was born at Alt-Seidenberg, in Upper Lusatia, a straggling hamlet among the hills, some ten miles S.E. of Görlitz. He came of a well-to-do family, but his first employment was that of hard boy on the Landskrone, a hill in the neighbourhood of Görlitz, and the only education he received was at the town-school of Seidenberg, a mile from his home. Seidenberg, to this day, is filled with shoemakers, and to a shoemaker Jakob was apprenticed in his fourteenth year (1589), being judged not robust enough for husbandry. Ten years later (1599) we find him settled at Görlitz as master-shoemaker, and married to Katharina, daughter of Hans Kuntzschmann, a thriving butcher in the town. After industriously pursuing his vocation for ten years, he bought (1610) the substantial house, which still preserves his name, close by the bridge, in the Neisse-Vorstadt. Two or three years later he gave up business, and did not resume it as a shoemaker; but for some years before his death he made and sold woollen gloves, regularly visiting Prague fair for this purpose.

Boehme's authorship began in his 37th year (1612) with a treatise, *Morgen Rösche im Aufgang*, which though unfinished was surreptitiously copied, and eagerly circulated in MS. by Karl von Ender. This raised him at once out of his homely sphere, and made him the centre of a local circle of liberal thinkers, considerably above him in station and culture. The charge of heresy was, however, soon directed against him by Gregorius Richter, then pastor primarius of Görlitz. Feeling ran so high after Richter's pulpit denunciations, that, in July 1613, the municipal council, fearing a disturbance of the peace, made a show of examining Boehme, took possession of his fragmentary quarto, and dismissed the writer with an admonition to meddle no more with such matters. For five years he obeyed this injunction. But in 1618 began a second period of authorship; he poured forth, but did not publish, treatise after treatise, expository and polemical, in the next and the two following years. In 1622 he composed nothing but a few short pieces on true repentance, resignation, &c., which, however, devotionally speaking, are the most precious of all his writings. They were the only pieces offered to the public in his lifetime and with his permission, a fact which is evidence of the essentially religious and practical character of his mind. Their publication at Görlitz, on New Year's Day 1624, under the title of *Der Weg zu Christo*, was the signal for renewed clerical hostility. Boehme had by this time entered on the third and most prolific though the shortest period (1623-4) of his speculation. His labours at the desk were interrupted in May 1624 by a summons to Dresden, where his famous "colloquy" with the Upper Consistorial Court was made the occasion of a flattering but transient ovation on the part of a new circle of admirers. Richter died in August 1624, and Boehme did not long survive his pertinacious foe. Seized with a fever when away from home, he was with difficulty conveyed to Görlitz. His wife was at Dresden on business; and during the first week of his malady he was nursed by

a literary friend. He died, after receiving the rites of the church, grudgingly administered by the authorities, on Sunday, 17th November. Clerical ill-will followed him to the grave, and the malice of the vulgar defaced his monument.

Boehme always professed that a direct inward opening or illumination was the only source of his speculative power. He pretended to no other revelation. Ecstatic raptures we should not expect, for he was essentially a Protestant mystic. No "thus saith the Lord" was claimed as his warrant, after the manner of Antoinette Bourignon, or Ludowick Muggleton; no spirits or angels held converse with him as with Swedenborg. It is needless to dwell, in the way either of acceptance or rejection, on the very few occasions in which his outward life seemed to him to come into contact with the invisible world. The apparition of the pail of gold to the hard boy on the Landskrone, the visit of the mysterious stranger to the young apprentice, the fascination of the luminous aseen, reflected from a common pewter dish, which first, in 1600, gave an intuitive turn to his meditations, the heavenly music which filled his ears as he lay dying—none of these matters are connected organically with the secret of his special power. The mysteries of which he discoursed were not reported to him: he "beheld" them. He saw the root of all mysteries, the *Ungrund* or *Urgrund*, whence issue all contrasts and discordant principles, hardness and softness, severity and mildness, sweet and bitter, love and sorrow, heaven and hell. These he "saw" in their origin; these he attempted to describe in their issue, and to reconcile in their eternal result. He saw into the being of God; whence the birth or going forth of the divine manifestation. Nature lay unveiled to him, he was at home in the heart of things. "His own book, which he himself was," the microcosm of man, with his threefold life, was patent to his vision. Such was his own account of his qualification. If he failed it was in expression; he confessed himself a poor mouthpiece, though he saw with a sure spiritual eye.

It must not be supposed that the form in which Boehme's pneumatic realism worked itself out in detail was shaped entirely from within. In his writings we trace the influence of Theophr. Bombast von Hohenheim, known as Paracelsus (1493-1541), of Kaspar Schwenkfeld (1490-1561), the first Protestant mystic, and of Valentin Weigel (1533-1588). From the school of Paracelsus came much of his puzzling phraseology,—his *Turba* and *Tinctur* and so forth,—a phraseology embarrassing to himself as well as to his readers. His friends plied him with foreign terms, which he was delighted to receive, interpreting them by an instinct, and using them often in a corrupted form and always in a sense of his own. Thus the word *Idea* called up before him the image of "a very fair, heavenly, and chaste virgin." The title *Aurora*, by which his earliest treatise is best known, was furnished by Dr Balthasar Walther. These, however, were false helps, which only serve to obscure a difficult study, like the *Flagrat* and *Lubet*, with which his English translator veiled Boehme's own honest *Schreck* and *Lust*. There is danger lest his crude science and his crude philosophical vocabulary conceal the fertility of Boehme's ideas and the transcendent greatness of his religious insight. Few will take the pains to follow him through the interminable account of his seven *Quellgeister*, which remind us of Gnosticism; or even of his three first properties of eternal nature, in which his disciples find Newton's formulas anticipated, and which certainly bear a marvellous resemblance to the three *Äryai* of Schelling's *Theogentische Natur*. Boehme is always greatest when he breaks away from his fancies and his trammels, and allows speech to the voice of his heart. Then he is artless, clear, and strong; and no man can help listening to him, whether he dive deep down with the

conviction "ohne Gift und Grimm kein Leben," or rise with the belief that "the being of all beings is a wrestling power," or soar with the persuasion that Love "in its height is as high as God." The mystical poet of Sillesia, Joh. Angelus, discerned where Boehme's truest power lay when he sang—

"Im Wasser lebt der Fisch, die Pflanze in der Erden,  
Der Vogel in der Luft, die Sonn' am Firmament,  
Der Salamander muss im Feu'r erhalten werden,  
Und Gottes Herz ist Jakob Böhme's Element."

The three periods of Boehme's authorship constitute three distinct stages in the development of his philosophy. He himself marks a threefold division of his subject matter:—1. PHILOSOPHIA, i.e., the pursuit of the divine *Sophia*, a study of God in himself; this was attempted in the *Aurora*. 2. ASTROLOGIA, i.e., in the largest sense, cosmology, the manifestation of the divine in the structure of the world and of man; hereto belong, with others, *Die drei Principien göttlichen Wesens; Vom dreifachen Leben der Menschen, Von der Menschwerdung Christi; Von der Geburt und Bezeichnung aller Wesen* (known as *Signatura Rerum*). 3. THEOLOGIA, i.e., in Scougall's phrase, "the life of God in the soul of man." Of the speculative writings under this head the most important are *Von der Gual-wahl; Mysterium Magnum* (a spiritual commentary on Genesis); *Von Christi Testamenten* (the Sacraments).

Although Boehme's philosophy is essentially theological, and his theology essentially philosophical, one would hardly describe him as a philosophical theologian; and, indeed, his position is not one in which either the philosopher or the theologian finds it easy to make himself completely at home. The philosopher finds no trace in Boehme of a conception of God which rests its own validity on an accord with the highest canons of reason or of morals; it is in the actual not in the ideal that Boehme seeks God, whom he discovers as the spring of natural powers and forces, rather than as the goal of advancing thought. The theologian is staggered by a language which breaks the fixed association of theological phrases, and strangely reversing the usual point of view, characteristically pictures God as underneath rather than above. Nature rises out of Him; we sink into Him. The *Ungrund* of the unmanifested Godhead is boldly represented in the English translations of Boehme by the word *Abyss*, in a sense altogether unexplained by its Biblical use. In the *Theologia Germanica* this tendency to regard God as the *substantia*, the underlying ground of all things, is accepted as a foundation for piety; the same view, when offered in the colder logic of Spinoza, is sometimes set aside as atheistical. The procession of spiritual forces and natural phenomena out of the *Ungrund* is described by Boehme in terms of a threefold manifestation, commended no doubt by the constitution of the Christian Trinity, but exhibited in a form derived from the school of Paracelsus. From Weigel he learned a purely idealistic explanation of the universe, according to which it is not the resultant of material forces, but the expression of spiritual principles. These two explanations were fused in his mind till they issued forth as equivalent forms of one and the same thought. Further, Schwenkfeld supplied him with the germs of a transcendental exegesis, whereby the Christian Scriptures and the dogmata of Lutheran orthodoxy were opened up in harmony with his new-found views. Thus equipped, Boehme's own genius did the rest. A primary effort of Boehme's philosophy is to show how material powers are substantially one with moral forces. This is the object with which he draws out the dogmatic scheme which dictates the arrangement of his seven *Quellgeister*. Translating Boehme's thought out of the uncouth dialect of material symbols (as to which one doubts sometimes whether he means them as concrete

instances, or as pictorial illustrations, or as a mere *memoria technica*) we find that Boehme conceives of the correlation of two triads of forces. Each triad consists of a thesis, an antithesis, and a synthesis; and the two are connected by an important link. In the hidden life of the Godhead, which is at once *Nichts* and *Alles*, exists the original triad, viz., Attraction, Diffusion, and their resultant, the Agony of the unmanifested Godhead. The transition is made; by an act of will the divine Spirit comes to Light; and immediately the manifested life appears in the triad of Love, Expression, and their resultant, Visible Variety. As the action of contraries and their resultant are explained the relations of soul, body, and spirit; of good, evil, and free will; of the spheres of the angels, of Lucifer, and of this world. It is a more difficult problem to account on this philosophy for the introduction of evil. Boehme does not resort to dualism, nor has he the smallest sympathy with a pantheistic repudiation of the fact of sin. That the difficulty presses him is clear from the progressive changes in his attempted solution of the problem. In the *Aurora* nothing save good proceeds from the *Ungrund*, though there is good that abides and good that falls—Christ and Lucifer. In the second stage of his writing the antithesis is directly generated as such; good and its contrary are coincidentally given from the one creative source, as factors of life and movement; while in the third period evil is a direct outcome of the primary principle of divine manifestation—it is the wrath side of God. Corresponding to this change we trace a significant variation in the moral end contemplated by Boehme as the object of this world's life and history. In the first stage the world is created in remedy of a decline; in the second, for the adjustment of a balance of forces; in the third, to exhibit the eternal victory of good over evil, of love over wrath.

Boehme's influence has lain chiefly with the learned. Translations of sundry treatises have been made into Latin (by J. A. Werdenhagen, 1632), Dutch (complete, by W. v. Bayerland, 1634-41), and French (by Jean Macle, *circa* 1640, and L. C. de Saint-Martin, 1800-9). For the nearest approach to popularity which his writings have enjoyed we must search the annals of the English Commonwealth. Between 1644 and 1662, all Boehme's works were translated by John Ellistone (d. 1652) and John Sparrow, assisted by Durand Hotham and Humphrey Blunden, who paid for the undertaking. At that time regular societies of *Boehmists*, embracing not only the cultivated but the vulgar, existed in England and in Holland. They merged into the Quaker movement, holding already in common with Friends that salvation is nothing short of the very presence and life of Christ in the believer, and only kept apart by an objective doctrine of the sacraments which exposed them to the polemic of Quakers (*e.g.*, J. Aenderdon). Muggleton led an anthropomorphic reaction against them, and between the two currents they were swept away. The Philadelphian Society at the beginning of the 18th century consisted of cultured mystics, Jane Lead, Pordage, Francis Lew, Bromley &c., who fed upon Boehme. William Law (1686-1761) somewhat later recurred to the same spring, with the result, however, in those dry times of bringing his own good sense into question rather than of reviving the credit of his author. After Law's death the old English translation was in great part re-edited (4 vols. 1762-84) as a tribute to his memory, by George Ward and Thomas Langcake, with plates from the designs of D. A. Freher (Brit. Mus. Add. MSS. 5767-94). This forms what is commonly called Law's translation; to complete it a 5th vol. (12mo, Dublin, 1820) is needed. Germany has also in this century turned to Boehme with eyes directly philosophical. "He is known," says Hegel, "as the *Philosophus Teutonicus*; and in reality through him for the first time did philosophy in Germany come forward with a characteristic stamp. The kernel of his philosophizing is purely German" (*Gesch. Ph.*, iii. 1836, p. 300). Franz Baader is the most remarkable of his recent philosophical exponents. See also Hamberger, *Die Lehre des deutschen Philosophen J. Boehme*, 1844; Alb. Pulp, *J. Boehme der deutsche Philosoph*, 1860; von Harless, *J. Boehme und die Alchymisten*, 1870. For Boehme's life, consult the *Memoirs*, by Abm. von Frankenberg and others, trans. by Fms. Okely, 1870; La Motte Fouquet's *J. Boehme, ein biographischer Denkstein*, 1831; and, above all, H. A. Reulner's *J. Boehme, sein Leben und seine Schriften*, 1857. A comprehensive study of Boehme in English is a desideratum. See *Memorial of W. Law* (by Chr. Walton, 1856); *Sat. Rev.*, xxxv.

(1878) p. 52; *Unilar. Rev. (Amer.)*, il. (1874) pp. 243, 447, art. by Prof. E. E. Thomson. Boehme's MSS. went to Holland. His works, having been separately printed at Amsterdam, 1681-82, by Hen. Beets and others, were first uniformly edited by J. G. Giehtel, Amst. 1682-3, in 24 pts. 8vo, bound in 6, 7, or 9 vols.; reprinted Amst. 1715, 2 vols. 4to; again, Amst. 1780-1, in 21 pts. 8vo, bound in 6 vols. They were re-edited by K. W. Schiebler, Leipz. 1831-47, in 7 vols. 8vo; reprinted 1861, *f.*

**BCŒOTIA** (*Boœotia*) a country of Central Greece, bounded on the S. by the Gulf of Corinth, Megaris, and Attica; on the E. by Attica and the Euripus, which separates it from Eubœa; on the N. by the territory of the Locri Opuntii; and on the W. by Phocia. Its surface is estimated at 1119 English square miles. Surrounded nearly on all sides by mountains, it divides itself naturally into three parts, the low country about Lake Copais, or, as it is now called, the Lake of Topolias, the valley of the River Asopus (now Oropo), and the coast district between Mount Helicon and the Corinthian Gulf. The country about the lake is a large valley, so completely surrounded by hills that it is connected with the Eubœan Sea by subterranean passages only. The natural passages, or *katavothra*, not being sufficient to carry off the great masses of water accumulating in the valley, which is traversed by the Cephissus, the principal river in the country, the early inhabitants often suffered severely from inundations; and at a very remote period large artificial drains were constructed, probably by the Minyans of Orchomenos, to supplement the natural outlets. Remains of these works, as stupendous as any that were erected in antiquity, still excite the admiration of the traveller. They formerly rendered that part of Boœotia one of the most fertile districts of Greece, but being neglected for centuries, the shores of the lake became an extensive marsh. A large stretch of country is still often under water during the winter, but it begins to dry up in spring, and in summer forms fine wheat-fields and meadows. Between this valley of the Copais and the basin of the Asopus is situated the Theban plain, which is still distinguished for its fertility, especially in grain. The lowlands and valleys of Boœotia were notorious in antiquity for their moist and thick atmosphere, which was believed to render the inhabitants dull and stupid. For these characteristics the Boœotians are frequently satirized by the Attic writers; and it is certain that comparatively few names were added to the long roll of Greek literature from this portion of the Greek soil. One writer alone, perhaps, the poet Pindar, stands out in striking contrast to the national character; the two others who alone of his fellow-countrymen can claim to be also his intellectual kinsmen, Hesiod and Ptolemy, bear no small trace of a Boœotian origin. The dialect spoken by the Boœotians was a broad Æolic. In the earliest times of history Boœotia was inhabited by various tribes, such as the Aoniens, Temmicians, Thracians, Leleges, Phlegyans, and the Minyans of Orchomenos. Of these we know almost nothing, but the last-mentioned appear to have formed a great centre of civilization at a very remote period. All these tribes were gradually expelled or absorbed by the Boœotian Æolians, who immigrated from Thessaly about sixty years after the destruction of Troy, according to the ordinary chronology. The country, which had previously possessed no common name, henceforth is always spoken of as Boœotia, and the several cities and towns, with Thebes at their head, formed a sort of confederation, in which, however, the Thebans and the other Boœotians frequently came into hostile collision, Thebes claiming the supremacy of the whole country, and the other cities insisting on their independence. The confederation was administered by a number of officers called Boœotarchs, of whom two were chosen by Thebes and one by each of the remaining confederate communities. The federal temple was that of Athene Itonica

at Coronea, and there a religious festival was held. The political history of the country is inseparable from that of **ORCHOMENOS**, **THEBES**, **PLATEÆ**, and **THESPÆ**, to which the reader must be referred for details. The confederacy continued its nominal existence even under the Roman emperors, although the country was so reduced that, about the time of Augustus, Tanagra and Thespis alone could be considered towns, the other cities having either been entirely destroyed, or existing only as villages. The more important of the towns which had formerly existed, besides those already mentioned, were Tegyra, Arne, Haliartus, Alalcomene, and Lebadea in the Copaic valley; Anthedon, Mycalessus, and Oropus along the Euripus; Thisbe and Creusis on the Corinthian Gulf; Ascrea and Leuctra further inland; and Side, Tanagra, and Phers in the valley of the Asopus. During the Middle Ages and under the Turkish domination, Livadia, the ancient Lebadea, was the capital of the country, which indeed was frequently called after that city. The district is now united in one *Nomus* with Attica (Attikiviotia), and is divided into two eparchies that take their names from Thebes and Livadia. The population in the eastern part is largely Albanian, and is engaged in the growing of grain and culture of the vine. See the Travels of Clarke, Wheler, Dodwell, Sir W. Gell, Hobhouse, Holland, Leake, and Mure; Thiersch, *État actuel de la Grèce*, 1833; Forchhammer, *Hellenika*, 1837; Kruse, *Hellas*, 1825-28; Klitz, *De fœderis Boœotico*, 1821; Ten Brunel, *De fœderis Boœotico*, 1834; Francke, *Der Boœotische Bund*, 1843; and Bursian's *Geographie von Griechenland*, 1863.

**BOERHAAVE**, **HERMANN**, one of the most celebrated physicians of modern times, was born at Voorhout near Leyden, December 31, 1668. Destined for the clerical profession, to which his father belonged, he received a liberal education, and early displayed unusual abilities. At the age of sixteen he entered the University of Leyden, where he studied under Gronovius, Ryckius, Trigland, and other distinguished men, and obtained the highest academical honours. In 1690 he took his degree in philosophy; on which occasion he delivered an inaugural dissertation *De distinctione mentis a corpore*, wherein he attacked the doctrines of Epicurus, Hobbes, and Spinoza. Being left, on the death of his father, without any provision, he was compelled to support himself by teaching mathematics. By the advice of Vandenberg, the burgomaster of Leyden, Boerhaave now applied himself with ardour to the study of medicine, to which indeed he had early manifested a decided inclination. The works of Hippocrates among the ancients, and those of Sydenham among the moderns, were the especial objects of his study; but his reading was by no means confined to these authors. In 1693 he took his degree of M.D. at Harderwyck in Guelderland, and immediately entered on the studies of his profession. His merits were soon recognized, and in 1701 he was appointed by the University of Leyden to supply the place of Dreilincourt as lecturer on the institutes of medicine. His inaugural discourse on this occasion was entitled *De commendando Hippocratis studio*, in which he recommended to his pupils that great physician as their model. In 1709, the university appointed him successor to Hottin in the chair of botany and medicine, in which capacity he did good service, not only to his own university, but also to botanical science, by his improvements and additions to the botanic garden of Leyden, and by the publication of numerous works descriptive of new species of plants. He was appointed in 1714 rector of the university. In the same year he succeeded Bidloo in the chair of practical medicine, and in this capacity he had the merit of introducing into modern practice the system of clinical instruction. Four years later he was appointed to the

chair of chemistry, and delivered an inaugural discourse, which contains the germs of his celebrated *Elements of Chemistry*. In 1728 he was elected into the Royal Academy of Sciences of Paris, and two years later into the Royal Society of London; to both of which he communicated his chemical researches. In 1729 declining health obliged him to resign the chairs of chemistry and botany; and in 1731 he resigned the rectorship of the university, to which office he had been re-elected. On this occasion he delivered a discourse *De Honore Medici Servitutis*. This great and good man died, after a lingering and painful illness, on the morning of the 23d September 1738.

From the time of Hippocrates, no physician had more justly merited the esteem of his contemporaries and the admiration of posterity than Boerhaave. To uncommon intellectual abilities he united those amiable qualities of the heart which give them so great a value to society. His personal appearance was simple and venerable. He taught very methodically, and with great precision; his style was eloquent, and his delivery dignified and graceful. He sometimes also gave his lectures a lively turn; but his raillery was never coarse or satirical. He possessed remarkable powers of memory, and was an accomplished linguist. A declared foe to all excess, he considered decent mirth as the salt of life. He was fond of music, with which he had a scientific acquaintance; and during winter he had a weekly concert in his house. It was his daily practice throughout life, as soon as he rose in the morning, which was generally very early, to retire for an hour to private prayer and meditation on some part of the Scriptures. He often told his friends, when they asked him how it was possible for him to go through so much fatigue, that it was this practice which gave him spirit and vigour in the business of the day.

Of his sagacity, and the wonderful penetration with which he often discovered and described, at first sight, such distempers as betray themselves by no symptoms to common eyes, very surprising accounts have been transmitted to us. Yet so far was he from having presumptuous confidence in his own abilities, or from being puffed up by prosperity, that he was condescending to all, and remarkably diligent in his profession. His great skill and celebrity as a physician brought him a large fortune. He left his only surviving daughter two millions of florins.

The genius of Boerhaave raised the fame of the University of Leyden, especially as a school of medicine, so as to make it a resort of strangers from every part of Europe. All the princes of Europe sent him disciples, who found in this skilful professor not only an indefatigable teacher, but an affectionate guardian. When Peter the Great went to Holland in 1715, to instruct himself in maritime affairs, he also took lessons from Boerhaave. The reputation of this eminent man was not confined to Europe; a Chinese mandarin wrote him a letter directed "To the illustrious Boerhaave, physician in Europe," and it reached him in due course. The city of Leyden raised a splendid monument to his memory in the church of St Peter, inscribed "To the health-giving genius of Boerhaave," SALUTIFERO BOERHAAVH GENIO SACRUM.

The principal works of Boerhaave are—(1.) *Institutiones Medicæ*, Leyden, 1708; (2.) *Aphorismi de cognoscendis et curandis Morbis*, Leyden, 1709,—on this work, which was the text-book of Boerhaave's lectures, Van Swieten published a commentary in 5 vols. 4to; (3.) *Libellus de Materia Medica et Remediorum Formulæ*, Leyden, 1719; (4.) *Institutiones et Experimenta Chemicæ*, Paris, 1724.

BOETIUS, ANICIUS MANLIUS SEVERINUS, is described by Gibbon "as the last of the Romans whom Cato or Tully could have acknowledged for their countryman." The events of his life are involved in uncertainty. The

historians of the day give us but imperfect records or make unsatisfactory allusions. Later chroniclers indulged in the fictitious and the marvellous, and it is almost exclusively from his own books that trustworthy information can be obtained.

There is considerable diversity among authorities as to the name of Boetius. One editor of his *De Consolatione*, Bertius, thinks that he bore the prænomen of Flavius, but there is no authority for this supposition. His father bore the name of Flavius, and it is probable that the Flavius Boetius who was prætorian præfect, and who was put to death in 455 A.D., by order of Valentinian III., was the grandfather of the subject of our notice; but these circumstances form no good reason for supposing that he also had the prænomen of Flavius. Many of the earlier editions inserted the name of Torquatus, but it is not found in any of the best manuscripts. The last name is generally written Boethius, from the idea that it is connected with the Greek *Boéthos*; but here, again, the best manuscripts agree in reading Boetius, and the latest editors have adopted this form.

The date of his birth is unknown; but it is conjectured on good grounds that he was born at Rome somewhere about the year 475 A.D. He was, therefore, too young to see the last of the Roman emperors (476), and his boyhood was spent in Rome while Odoacer, king of the Heruli, was monarch of that city. We know nothing of his early years. A passage in a treatise falsely ascribed to him (*De Disciplina Scholarium*) and a misinterpretation of a passage in Cassiodorus, led early scholars to suppose that he spent a long time in Athens pursuing his studies there; but later biographers have seen that there is no foundation for this opinion. His father, Flavius Manlius Boetius was consul in the year 487. It is probable that he died soon after; for Boetius states that, when he was bereaved of his parent, men of the highest rank took him under their charge (*De Con.*, lib. ii. c. 3). He soon became well known for his energy and ability, and his high rank gave him access to the noblest families. He married Rusticius, the daughter of the senator Symmachus. By her he had two sons, Anicius Manlius Severinus Boetius and Q. Aurelius Memmius Symmachus. When Theodoric, the king of the Ostrogoths, displaced Odoacer no change of fortune for the worse seems to have befallen Boetius. On the contrary he became a favourite with that monarch, and was one of his intimate friends. Boetius attained to the consulship in 510, and his sons, while still young, held the same honour together (522). Boetius regarded it as the height of his good fortune when he witnessed his two sons, consuls at the same time, convoyed from their home to the senate-house by a crowd of senators amidst the enthusiasm of the masses. On that day, he tells us, while his sons occupied the curule chairs in the senate-house, he himself had the honour of pronouncing a panegyric on the monarch, and placed between his two sons he distributed largesses among the people in the circus. But his good fortune did not last, and he attributes the calamities that came upon him to the ill-will which his bold maintenance of justice had caused, and to his opposition to every oppressive measure. "How often," he says, "have I opposed the attacks of Conigastus on the property of the weak! how often have I kept Triguilla, the chamberlain of the palace, from perpetrating acts of injustice! how often have I protected, by influence exercised at my own peril, the miserable whom the licensed avarice of the barbarians always harassed with endless insults!" And then he mentions several particular cases. A famine had begun to rage. The præfect of the prætorium was determined to satisfy the soldiers, regardless altogether of the feelings of the provincials. He accordingly issued an edict for a *coemptio*, that is, an order compelling the provincials

to sell their corn to the Government, whether they would or not. This edict would have utterly ruined Campania. Boetius interfered. The case was brought before the king, and Boetius succeeded in averting the *coemptio* from the Campanians. He also rescued Paulinus, a man of consular rank, from the jaws of those whom he calls *palatina canes* (dogs of the palace), and who, he says, had almost devoured his riches. And he gives as a third and crowning instance in that he exposed himself to the hatred of the informer Cyprianus by preventing the punishment of Albinus, a man of consular rank. He mentions in another place that when at Verona the king was anxious to transfer the accusation of treason brought against Albinus to the whole senate, he defended the senate at great risk. In consequence of the ill-will that Boetius had thus roused, he was accused of treason towards the end of the reign of Theodoris. Three accusers appeared against him. The first, Basilus, had been expelled from the monarch's service, and in consequence of debt he had become an informer and now appeared against Boetius. The other two were Opilio and Gaudentius, on whom sentence of banishment had been pronounced on account of innumerable frauds. They first took refuge in a church, but when this fact became known, a decree was issued that if they did not leave Ravenna before a prescribed day, they were to be driven out with a brand upon their forehead. On the very last day allowed them they gave information against Boetius, and their information was received. The accusation which these villains brought against him was that he had conspired against the king, that he was anxious to maintain the integrity of the senate, and to restore Rome to liberty, and that for this purpose he had written to the Emperor Justin. Justin had, no doubt, special reasons for wishing to see an end to the reign of Theodoris. Justin was orthodox. Theodoris was an Arian. The orthodox subjects of Theodoris were suspicious of their ruler; and many would gladly have joined in a plot to displace him. The knowledge of this fact may have rendered Theodoris suspicious. But Boetius denied the accusation in unequivocal terms. He did indeed wish the integrity of the senate. He would fain have desired liberty, but all hope of it was gone. The letters addressed by him to Justin were forgeries, and he had not been guilty of any conspiracy. Notwithstanding his innocence he was condemned and sent to Ticinum (Pavia) where he was thrown into prison. It was during his confinement in this prison that he wrote his famous work *De Consolatione Philosophica*. His goods were confiscated, and after an imprisonment of considerable duration he was put to death in 525. Procopius relates that Theodoris soon repented of his cruel deed, and that his death, which took place soon after, was hastened by remorse for the crime he had committed against his great counsellor.

Two or three centuries after the death of Boetius writers began to view his death as a martyrdom. Several Christian books were in circulation which were ascribed to him, and there was one especially on the Trinity which they regarded as proof that he had taken an active part against the heresy of Theodoris. It was therefore for his orthodoxy that Boetius was put to death. And these writers delight to paint with minuteness the horrible tortures to which he was exposed and the marvellous actions which the saint performed at his death. He was canonized as Saint Severinus. The brick tower in Pavia in which he was confined was a hallowed building. And finally, in the year 998, Otho III. ordered the bones of Boetius to be taken out of the place in which they had lain hid, and to be placed in the church of St Augustine within a splendid marble tomb, for which Gerbert, who afterwards became Pope under the name of Silvester II., wrote an inscription.

It should be mentioned also that some have given him a decidedly Christian wife, of the name of Elpis, who wrote hymns, two of which are still extant (Daniel, *Thea Hymna.*, i. p. 156). This is a pure supposition inconsistent with chronology, unauthenticated by authority, and based only on a misinterpretation of a passage in the *De Consolatione*.

The contemporaries of Boetius regarded him as a man of profound learning. Priscian the grammarian speaks of him as having attained the summit of honesty and of all sciences. Cassiodorus, the chancellor of Theodoris and the intimate acquaintance of the philosopher, employs language equally strong. And Ennodius, the bishop of Pavia, knows no bounds for his admiration. "You surpass," he says to Boetius, "the eloquence of the ancients in imitating it." The king Theodoris had a profound idea of his great scientific abilities. He employed him in setting right the coinage. When he visited Rome with Gunibald king of the Burgundians, he took him to Boetius, who showed them, amongst other mechanical contrivances, a sundial and a water-clock. The foreign monarch was astonished, and, at the request of Theodoris, Boetius had to prepare others of a similar nature, which were sent as presents to Gunibald. It was Boetius also whom Theodoris consulted when Clovis, king of the Franks, wished a musician who could sing to the accompaniment of the lyre, and Boetius was charged with the duty of selecting him.

The fame of Boetius increased after his death, and his influence during the Middle Ages was exceedingly powerful. His circumstances peculiarly favoured this influence. He appeared at a time when contempt for intellectual pursuits had begun to pervade society. In his early years he was seized with a passionate enthusiasm for Greek literature, and this continued through life. Even amidst the cares of the consulship he found time for commenting on the *Categories* of Aristotle. The idea laid hold of him of reviving the spirit of his countrymen by imbuing them with the thoughts of the great Greek writers. He formed the resolution to translate all the works of Aristotle and all the dialogues of Plato, and to reconcile the philosophy of Plato with that of the Stagirite. He did not succeed in all that he designed; but he did a great part of his work. "Through your translations," says Cassiodorus to him, "the music of Pythagoras and the astronomy of Ptolemaeus are read by the Italians; the arithmetic of Nicomachus and the geometry of Euclid are heard by the Westerns; the theology of Plato and the logic of Aristotle dispute in the language of Quirinus; the mechanical Archimedes also you have restored in a Latin dress to the Sicilians; and whatever discipline or arts fertile Greece has produced through the efforts of individual men, Rome has received in her own language through your single instrumentality." Boetius translated into Latin Aristotle's *Analytica Priora et Posteriora*, the *Topica*, and *Elencha Sophistici*; and he wrote commentaries on Aristotle's *Categories*, on his book *peri interpretationis*, also a commentary on the *Isagoge* of Porphyrius. These works formed to a large extent the source from which the Middle Ages derived their knowledge of Aristotle. (See Stahr, *Aristoteles bei den Römern*, pp. 196-234.)

But Boetius did not confine himself to Aristotle. He wrote a commentary on the *Topica* of Cicero; and he was also the author of independent works on logic:—*Introductio ad Categorias Syllogismos*, in one book; *De Syllogismo Categorico*, in two books; *De Syllogismis Hypotheticis*, in two books; *De Divisione*, in one book; *De Definitione*, in one book; *De Differentiis Topicis*, in four books.

We have also seen from the statement of Cassiodorus that he furnished manuals for the quadrivium of the schools of the Middle Ages (the "*quattuor mathematicas disciplinas*,"

as Boetius calls them) on arithmetic, music, geometry, and astronomy. The statement of Cassiodorus that he translated Nicomachus is rhetorical. Boetius himself tells us in his preface addressed to his father-in-law Symmachus that he had taken liberties with the text of Nicomachus, that he had abridged the work when necessary, and that he had introduced formulae and diagrams of his own where he thought them useful for bringing out the meaning. His work on music also is not a translation from Pythagoras, who left no writing behind him. But Boetius belonged to the school of musical writers who based their science on the method of Pythagoras. They thought that it was not sufficient to trust to the ear alone, to determine the principles of music, as did practical musicians like Aristoxenus, but that along with the ear, physical experiments should be employed. The work of Boetius is in five books, and is a very complete exposition of the subject. It remained a text-book of music in the Universities of Oxford and Cambridge till within comparatively recent times. It is still very valuable as a help in ascertaining the principles of ancient music, and gives us the opinions of some of the best ancient writers on the art. The manuscripts of the geometry of Boetius differ widely from each other. The latest editor, Godofredus Friedlein, thinks that there are only two manuscripts which can at all lay claim to contain the work of Boetius. He has published the *Arithmetica*, in two books, as given in these manuscripts; but critics are generally inclined to doubt the genuineness even of these.

By far the most important and most famous of the works of Boetius is his book *De Consolatione Philosophiæ*. Gibbon justly describes it as "a golden volume, not unworthy of the leisure of Plato or Tully, but which claims incomparable merit from the barbarism of the times and the situation of the author." It was a favourite book of the Middle Ages, and deserves to be a favourite still. The high reputation it had in mediæval times is attested by the numerous translations, commentaries, and imitations of it which then appeared. Among others Asser, the instructor of Alfred the Great, and Robert Grosseteste, bishop of Lincoln, commented on it. Alfred translated it into Anglo-Saxon. Versions of it appeared in German, French, Italian, Spanish, and Greek before the end of the 15th century. Chaucer translated it into English prose before the year 1382; and this translation was published by Caxton at Westminster, 1480. Lydgate followed in the wake of Chaucer. It is said that, after the invention of printing, amongst others Queen Elizabeth translated it, and that the work was well known to Shakespeare.

This famous work consists of five books. Its form is peculiar, and is an imitation of a similar work by Marcianus (Capella, *De Nuptiis Philologie et Mercurii*). It is alternately in prose and verse. The verse shows great facility of metrical composition, but a considerable portion of it is transferred from the tragedies of Seneca. The first book opens with a few verses, in which Boetius describes how his sorrows had turned his hair grey, and had brought him to a premature old age. As he is thus lamenting, a woman appears to him of dignified mien, whom for a time he cannot distinguish in consequence of his tears, but at last he recognizes her as his guardian, Philosophy. She, resolving to apply the remedy for his grief, puts some questions to him for that purpose. She finds that he believes that God rules the world, but does not know what he himself is; and this absence of self-knowledge is the cause of his weakness. In the second book Philosophy presents to Boetius Fortune, who is made to state to him the blessings he has enjoyed, and after that proceeds to discuss with him the kind of blessings that fortune can bestow, which are shown to be unsatisfactory and uncertain. In the third book Philosophy promises to lead him to true happiness, which is to be found in God alone, for since God is the highest good, and the highest good is true happiness, God is true happiness. Nor can real evil exist, for since God is all-powerful, and since he does not wish evil, evil must be non-existent. In the fourth book Boetius raises the question, Why, if the governor of the universe is good, do evils exist, and why is virtue often punished and vice rewarded? Philo-

sophy proceeds to show that this takes place only in appearance; that vice is never punished nor virtue unrewarded. From this Philosophy passes into a discussion in regard to the nature of providence and fate, and shows that every fortune is good. The fifth and last book takes up the question of man's free will and God's foreknowledge, and, by an exposition of the nature of God, attempts to show that these doctrines are not subversive of each other; and the conclusion is drawn that God remains a foreknowing spectator of all events, and the ever-present eternity of his vision agrees with the future quality of our actions, dispensing rewards to the good and punishments to the wicked.

Several theological works have been ascribed to Boetius, as has been already mentioned. The *Consolatio* affords conclusive proof that the author was not a practical believer in Christianity. The book contains several expressions, such as *daemones*, *angelica virtus*, and *purgatoria clementia*, which have been thought to be derived from the Christian faith; but they are used in a heathen sense, and are explained sufficiently by the circumstance that Boetius was on intimate terms with Christians, and could not help being influenced to some extent by their language. The writer nowhere finds consolation in any Christian belief, and Christ is never named in the work. It is not impossible, however, that Boetius may have been brought up a Christian, and that in his early years he may have written some Christian books. This is the conjecture to which the latest editor of his Christian treatises has had recourse. Peiper thinks that the first three treatises are the productions of the early years of Boetius. The first, *De Sancta Trinitate*, is addressed to Symmachus (Domino Patri Symmacho), and the result of the short discussion, which is of an abstract nature, and deals partly with the ten categories, is that unity is predicated absolutely, or, in regard to the substance of the Deity, trinity is predicated relatively. The second treatise is addressed to John the deacon ("Ad Joannem Diaconum"), and its subject is "Utrum Pater et Filius et Spiritus Sanctus de divinitate substantialiter predicentur." The treatise is shorter than the former, occupying only two or three pages, and the conclusion of the argument is the same. The third treatise bears the title, *Quomodo substantia in eo quod sint bona sint cum non sint substantia bona*. It contains nothing distinctly Christian, and it contains nothing of great value; therefore its authorship is a matter of little consequence. Peiper thinks that, as the best MSS. uniformly assign these treatises to Boetius, they are to be regarded as his; that it is probable that Symmachus and John (who afterwards became Pope) were the men of highest distinction who took charge of him when he lost his father; and that these treatises are the first-fruits of his studies, which he dedicates to his guardians and benefactors. He thinks that the variations in the inscriptions of the fifth treatise, which is not found in the best manuscript, are so great that the name of Boetius could not have originally been in the title. The fourth book is also not found in the best manuscript, and two manuscripts have no inscription. He infers from these facts, that there is no sure evidence for the authorship of the fourth and fifth treatises. The fifth treatise is *Contra Eutycheum et Nestorium*. Both Eutycheus and Nestorius are spoken of as living. A council is mentioned, in which a letter was read, expounding the opinion of the Eutycheians for the first time. The novelty of the opinion is also alluded to. All these circumstances point to the Council of Chalcedon (451). The treatise was therefore written before the birth of Boetius, if it be not a forgery; but there is no reason to suppose that the treatise was not a genuine production of the time to which it professes to belong. The fourth treatise, *De Fide Catholica*, does not contain any distinct chronological data; but the tone and opinions of the treatise produce the impression that it probably belonged to the same period as the treatise against Eutycheus and Nestorius. Several inscriptions ascribe both these treatises to Boetius. It will be seen from this statement that Peiper bases his conclusions on grounds far too narrow; and on the whole it is far more probable that Boetius wrote none of the four Christian treatises, particularly as they are not ascribed to him by any of his contemporaries. Three of them express in the strongest language the orthodox faith of the church in opposition to the Arian heresy, and these three put in unmistakable language the procession of the Holy Spirit from both Father and Son. The fourth argues for the orthodox belief of the two natures and one person of Christ. When the desire arose that it should be believed that Boetius perished from his opposition to the heresy of Theodoric, it was natural to ascribe to him works which were in harmony with this supposed fact. The works may really have been written by one Boetius, a bishop of Africa, as Jourdain supposes, or by some Saint Severinus, as Nitzsch conjectures, and the similarity of name may have aided the transference of them to the heathen or neutral Boetius.

The best editions of the entire works of Boetius are the Basal edition of 1570, and Migne's in his *Patrologia Cursus Completus, Series Latina*, vol. lxxii, lxxv. There are many editions of the *De Consolatione*. The most recent are—(1.) In Valpy's *Delphin Classics*, Nos. 54 and 55. This contains the lives of Boetius by Bertius and

by Bots, and a list of the various editions of Boetius. It has also numerous notes. (2.) An edition by Theodorus Obbarius, Jena, 1843. This contains prolegomena on the life and writings of Boetius, on his religion and philosophy, and on the manuscripts and editions, a critical apparatus, and notes. (3.) An edition by Rudolph Peiper, Lipsa, 1871. This edition has the fullest collection of manuscripts, though a considerable number of manuscripts still remain to be collated. In addition to an account of the MSS. used, it gives the Book of Lupus "De Metris Boetii," the "Vita Boetii" contained in some MSS., "Elogia Boetii," and a short list of the commentators, translators, and imitators of the *Consolation*. It contains also an account of the metres used by Boetius in the *Consolatio*, and a list of the passages which he has borrowed from the tragedies of Seneca. The work also includes the five treatises, four of them Christian, of which mention has been made above. In 1867 appeared a very satisfactory edition of Boetius's works, *De Institutione Arithmetica Libri Duo, De Institutione Musica Libri Quinque, Accedit Geometria qua fertur Boetii: e libris manuscriptis editis Godofredus Friedlein, Lipsia.* (J. D.)

**BOGHAZ-KEUY**, or **BOGHAS-KOHI** (*i.e.*, the Village of the Gorge), a small hamlet in Asia Minor, remarkable for its ruins, which are identified with the ancient Pterium or Pteria. It stands 3515 feet above the sea-level, about half-way between Angora and Amassia, almost in the 40th parallel of N. lat., on the banks of a small tributary of the Kizil Irmak. The present village contains about 150 houses, but the remains give evidence of its former importance. Almost all the heights they occupy bear traces of fortification; extensive chambers have been excavated in the rocks; many portions of escarpment are elaborately sculptured; and the massive foundations of a vast temple or palace can still be traced. The date and origin of these ruins have given rise to much discussion. Dr Barth thinks the city was probably founded by Cyaxares, the Mede, and explains the groups of sculpture as commemorating the peace between Cyaxares and Alyattes, which is described by Herodotus in the 74th chapter of his 1st book. M. Texier's hypothesis, on the other hand, is that the carvings represent the introduction of the worship of Astarte into Phrygia; and this interpretation has been provisionally accepted by Van Lennep, in whose *Travels in Asia Minor*, 1870, carefully-drawn copies of the sculptures will be found. (See also Barth, *Reise von Trapezunt nach Sontari*, 1860, and in *Monatsbericht der Berl. Akad. der Wissenschaft.*, Febr., 1859.)

**BOGODUKHOFF**, a town of Russia, in the government of Kharkoff, about 43 miles N.W. of that city, in 50° 10' N. lat. and 36° 32' E. long., on the sandstone heights along the River Merl. There seems to have been a settlement on this site as early as 1571, and in 1681 it is spoken of as a town. In 1709, at the time of the Swedish war, Bogodukhoff was taken by Menschikoff and the Emperor Alexis Petrovitch. There are still remains of the ramparts and ditches with which it was formerly surrounded. The town contains four churches and a cathedral (of the Assumption, built in 1793), a hospital, and an almshouse. The inhabitants are chiefly engaged in agriculture and gardening, and in the manufacture of boots, caps, and furred gowns. Tanning also is carried on to some extent. The trade is principally in grain, cattle, and fish. There are two weekly markets and six annual fairs. Population in 1860, 10,522.

**BOGOMILI**, a heretical sect of the Greek Church, who came into notice during the 12th century. In origin they are probably Bulgarian, and their name appears to be a compound of the Slavonic words *Bog*, God, and *milui*, have mercy. In doctrine they are closely assimilated to the Euchites of the preceding century, and they may be looked on as an offshoot of that older sect. The peculiarity of their system of belief is the place assigned to Satan, who, under his original name Satanael, is held by them to be the first-born son of God. But Satanael, though seated at the right hand of his father and endowed with universal sway, was discontented and desired to become independent. He

led away a section of the angels from their allegiance, and with their aid formed out of chaos a new world—the earth, and a new race—man. But he was unable to give to man a portion of his own living spirit, and therefore besought God to bestow life on this new creation, promising that the vacant places of the seceded angels should be filled up by the spirits of men. Repenting of this promise, however, he resolved to bring forth an evil race which should overwhelm the good among mankind. He accordingly seduced Eve, who gave birth to Cain, the first of the descendants of the evil principle. His power also enabled him to deceive the greater part of mankind, particularly the Jews, to whom he represented himself as Jehovah. At last God sent out from himself the *Logos*, or angel Michael, who came upon earth in an ethereal form which was in appearance only an earthly body. Christ overcame Satanael, and deprived him of his creative power, *Et*, from which time he is called Satan. Christ then ascended and took his place beside the Father, who again sent forth an emanation, the Holy Ghost, for the comfort and edification of believers. In church observances the Bogomili were equally heterodox. They rejected baptism by water only, and made the ceremony consist of prayer, and of laying on the head of the convert the gospel (probably apocryphal) of St John, and the hands of the congregation. As they rejected the symbol of water in baptism so they refused to admit such symbolic rites as the Lord's supper, which they looked upon as an offering to evil spirits. They were averse to all images, even to the cross. The Bogomili suffered persecution from Alexius Comnenus, who put to death their leader Basilus, and they were condemned by a synod of Constantinople in 1140. They lingered on, however, in and about Philippopolis, and opinions nearly identical with theirs are to be met with among the later Catharists. (See the *Church Histories* of Neander and Gieseler.)

**BOGOTA**, or **SANTA FÉ DE BOGOTA**, the capital of the United States of Colombia, in South America, is situated in the state of Cundinamarca, in 4° 6' N. lat. and 78° 30' W. long. It occupies a fine position at the base of the mountains La Guadalupe and Montserrat, on a table-land that forms part of the eastern ridge of the Andes, between the extensive valley of the Magdalena and the plains that are watered by part of the Orinoco system. The surrounding country is exceedingly fertile, and produces abundant crops of wheat and barley and the leguminous plants cultivated in Europe. The city of Bogota is the finest in the republic; its streets are well built, and run at right angles to each other; and within recent years most of them have been supplied with side pavements. The private houses are built of sun-dried bricks, and white-washed; and owing to the prevalence of earthquakes they are mostly of one story in height. Of the streets the largest and finest is the Calle-Real or Calle de la Republica, which ends in a large square or plaza containing some of the chief buildings in the city. The cathedral, rebuilt in 1814, possesses very little external beauty; but its interior is fitted up with considerable elegance, its ornaments are rich and valuable, and the image of the Virgin, the patron saint, is covered with a profusion of precious stones. There are about thirty other churches in the city, but many of them are in a state of decay, while several of the monastic buildings are appropriated to secular uses,—the religious communities having been dissolved by Mosquera, and their revenues devoted in great measure to educational purposes. The convent of San Francisco is of great extent, and contains some of the productions of Vasquez, a native artist of merit. A large and elegant building—a capitol, for the reception of Congress and for the various offices of state—is now (1875) in course of erection. Besides the university there are three endowed colleges, a school of



chemistry and mineralogy, a national academy, a public library, a botanic garden, and a military school, which is supported out of the public funds, and has produced some good engineers. The mint, one of the three in the republic, is a large and handsome building, and is well supplied with the necessary machinery. There are manufactures of soap, cloth, leather, and the precious metals; an active trade is carried on; and the neighbourhood is rich in minerals of various kinds. The population in 1800 amounted to 21,464, exclusive of strangers and temporary residents; in 1821 it was estimated at 30,000, and in 1870 at about 52,000. Santa Fé de Bogota was founded in 1538 by Gonzalez Ximenes de Quesada, and received its name from his birthplace Santa Fé, with the addition of Bogota, in honour, it is said, of a native prince of that time. It soon increased in size and importance, and became the capital of the Spanish vice-royalty of New Granada. In 1811 the citizens threw off the Spanish yoke and a republic was proclaimed; the city, however, in 1816, fell into the hands of Murillo the Spanish general. Delivered by Bolivar in 1819 it was made capital of the republic of Colombia; on the separation of the three states it remained the chief city of New Granada, and it is now the capital of the United States of Colombia, forming itself an independent federal territory. It is the seat of the supreme court and the other offices of the Federal Government, and the residence of the foreign diplomatic representatives.

BOGRA, correctly *BAGURÁ*, a district in the *Rájsháhí* division, within the Lieutenant-Governorship of Bengal, situated between 25° 20' and 24° 20' 28" N. lat., and 88° 55' 30" and 89° 49' 25" E. long. It is bounded on the N. by the districts of Dinájpur and Rangpur, on the E. by the districts of Rangpur and Maimansinh, on the S. by the district of Pabná, and on the W. by the districts of *Rájsháhí* and Dinájpur. The revenue area, of the district in 1870 was 2000 square miles, of which 1750 were returned as under cultivation, 125 as cultivable but not actually cultivated, and 125 as uncultivable waste. The census of 1872 returned the police area of the district at 1500 square miles, and disclosed a population of 689,467 souls, of whom 556,620, or 80 per cent., were Mahometans; 130,644, or 19 per cent., Hindus; 22 Christians; and 2181 were classified as "others." Density of population in the census area, 59 per square mile. The district stretches out in a level plain, intersected by numerous streams and dotted with patches of jungle. The Karatoyá River flows from north to south, dividing the district into two portions, possessing very distinct characteristics. The eastern tract consists of rich alluvial soil, well watered, and subject to fertilizing inundations, yielding heavy crops of coarse rice, oilseeds, and jute. The western portion of the district is high-lying and produces the finer qualities of rice. The principal rivers are formed by the different channels of the *Brahmaputra*, which river here bears the local names of the *Konái*, the *Dáokobá*, and the *Jamuná*, the last forming a portion of the eastern boundary of the district. Its bed is studded with alluvial islands. The *Brahmaputra* and its channels, together with three minor streams, the *Bángálí*, *Karatoyá*, and *Alai*, afford admirable facilities for commerce, and render every part of the district accessible to native cargo boats of large burden. The rivers swarm with fish,—the value of the fisheries being estimated at £45,000 a year. The principal products of the district are rice, pease, pulses, oilseeds, jute, sugar-cane, mulberry, red pepper, and hemp for smoking (*Cannabis indica*). These products, together with clarified butter and a little silk, form the chief articles of export. The imports consist of salt, cloth, tobacco, areca-nuts, copper and brass utensils, spices, iron and piece goods. The chief trading markets are Bográ, *Lakhmiganj*, *Buriganj*,

*Dhupcháchiá*, &c. A silk factory has been established at *Naodápára*, and is conducted with European capital, with an annual outlay of about £4500. The revenue and expenditure of the district have steadily increased of late years. In 1853 the total revenue of the district amounted to £48,431, and the civil expenditure to £7282; in 1860, revenue £57,744, and civil expenditure £11,013; in 1870-71 the revenue had risen to £59,979. In 1870-71 the district contained 1064 separate estates held by 2497 proprietors, paying a total Government land revenue of £44,347. The machinery for protecting person and property consists of six magisterial and six civil courts, with (1) a regular police force, numbering 54 officers and 252 men, and costing Government £5975; (2), a rural constabulary or village watch, numbering 2552 men, and costing £6635, paid by the landholders and villagers; and (3), municipal police, numbering 36 men, and costing £251. In 1871-72 there were 41 Government and aided schools in the district, attended by 1492 pupils, and maintained at a total cost of £1398, of which £692 was contributed by the state. The total number of aided and unaided schools in the district is returned in the census of 1872 at 169, attended by 1685 pupils. The only town containing upwards of 5000 inhabitants in the district is Bográ, the administrative headquarters, situated on the *Karatoyá* River; population in 1872, 5872; municipal income, £282; expenditure, £208; rate of taxation per head, 11½d. There is one other municipality, *Sherpur*, formerly a place of importance when the East India Company had silk filatures in its neighbourhood. A great part of this town is now overgrown with jungle; the municipal income in 1869 was £246, the expenditure £174. The climate of Bográ is mild during the winter, but sultry and oppressive at other seasons. The average annual rainfall for the five years ending 1869 was 82 inches, and the average annual temperature 77° Fahr.

BOHADDIN, or, more properly, *BOHA-EDDYN*, an eminent Arabian writer and statesman, better known in the East under the appellation of *IRK-SYEDDAD*. He was born at Mosul 1145 A.D. (539 A.H.), and early became eminent in the study of the Koran, as well as in jurisprudence. At the age of twenty-seven he obtained the place of lecturer at Baghdad, and, soon after, a professor's chair at Mosul. In 1187 he made the pilgrimage to Mecca, and then proceeded to visit Jerusalem and Hebron. In passing through Damascus he was sent for by Saladin, who was then employed in the siege of Kancab. Bohaddin observed, as he himself mentions (*Vita Saladiní*, c. v.), that the whole soul of the monarch was engrossed by the war which he was then waging against the enemies of the faith, and saw that the only mode of securing his favour was by urging him to its vigorous prosecution. With this view he composed a treatise on the *Laws and Discipline of Sacred War*; and this work, on his return, he presented to Saladin, who received it with peculiar favour. Bohaddin, from this time, remained constantly attached to the person of the sultan, and was employed in various important embassies and departments of civil government. He was also appointed judge of the army, and judge of Jerusalem. After Saladin's death Bohaddin was active in securing the throne to his son, *Melik-al-Dhaker*, and was by that prince created *cadi* of Aleppo. He then founded a college in that city of which he himself was the principal professor. When *Melik-al-Dhaker* died, his son *Melik-al-Aziz* was a minor, and Bohaddin obtained the principal sway in the regency. This gave him an opportunity of introducing learned men at court, and loading them with honour. As the prince, however, approached to manhood, Bohaddin, though he still retained his offices, found it expedient to retire from court. Even after he was unable to go to college, he continued to

give lectures in his own house; and he persevered in these learned labours till the age of ninety, when he died 1235 A.D. (633 A.H.) Bohaddin wrote on jurisprudence and Muslim divinity; but his principal work is his *Life of Saladin*, which, with several other pieces connected with the same subject, was published by Schultens, at Leyden, in 1732, accompanied by a Latin translation, with notes and a geographical index. This work affords a favourable specimen of the historical compositions of the Arabs. It is written with some spirit, and yet is free from that inflation which so frequently disfigures Oriental composition. Whatever relates to Saladin breathes the highest tone of panegyric; yet the enthusiasm with which everything concerning him is narrated, and the anecdotes which the author, from his personal knowledge, is able to communicate respecting that extraordinary character, give his work a great degree of interest.

**BOHEMIA** (German *BÖHMEN* or *BÖHEMEN*), a kingdom of the Austrian empire, situated between 48° 33' and 51° 4' N. lat., and 12° 5' and 16° 25' W. long., and bounded on the N. by Saxony and Prussian Silesia, E. by Moravia, S. by Upper and Lower Austria, and W. by Bavaria. Its area is estimated at 19,983 square miles. It belongs almost entirely to the basin of the Elbe, which rises within the territory, and is joined by the Adler, the Iser, the Moldau, and the Eger before it passes the frontier. The boundaries are pretty clearly marked by mountain ranges on all sides,—the Böhmerwald dividing the country from Bavaria, the Erzgebirge and Riesengebirge from Saxony and Silesia, and the Moravian Hills from the basin of the Danube. The climate is healthy, but varies considerably in different districts; the soil in many parts is highly fertile, and grain of various kinds, potatoes, hops, flax, hemp, vines, and fruits are extensively cultivated. In 1870 there were 6,305,161 acres of ploughed land, 2656 in vineyards, 1,560,321 in gardens and meadows, 995,340 in pasture, and 3,749,411 in woodland. At the same date the number of horses in the country was 189,337, cattle 1,602,015, sheep 1,106,290, goats 194,273, swine 228,180, and bee-hives 140,892. The mineral productions comprise gold, silver, lead, tin, copper, iron, cobalt, blamuth, arsenic, sulphur, coal, alum, vitriol, and different sorts of stone. In 1870 there were obtained 156 cwt. of gold-ore, 1245 of silver-ore, 225,536 tons of iron, 999 tons of lead, 2274 of tin, 61 tons of antimony, and 111 of arsenic-ore. The quantity of coal and lignite amounted to 4,099,909 tons. The mineral springs of Bohemia—Carlsbad, Teplitz, Marienbad, and Franzensbrunn, &c.—are justly famous. The industry of the kingdom is highly developed in various directions. Most important of all is the manufacture of woollen goods, principally carried on at Reichenberg and in the neighbourhood. The cotton manufacture is also extensively prosecuted in the same district; and at Rumburg and other places linen stuffs are largely produced. Bohemian glass has been celebrated for centuries, and is still exported to all parts of Europe. Porcelain and earthenware of different sorts, iron and steel wares, copper, tin, and pewter articles, wooden wares, chemical stuffs, and paper are all the objects of a considerable industry. Beetroot sugar is pretty largely manufactured, the refineries numbering 126 in 1870. At the same date there were 968 breweries in the country, and 324 brandy distilleries. The chief commercial city is the capital, Prague; but Reichenberg, Pilsen, Haida, Rumburg, Leitmeritz, and Budweis are all important centres. Bohemia is divided into twelve circles—Prague, budweis, Pisek, Pilsen, Eger, Saas, Leitmeritz, Bunslau, Jiczin, Königgrätz, Chrudin, Czeslau, and Tabor, and these are subdivided into 91 departments. In 1869 there were 372 towns, 226 smaller market-towns, and 12,551 villages. The number of inhabited houses in the whole country amounted to

632,404; and the total population was 5,106,069, of whom 2,433,629 were males, and 2,672,440 females. The census of 1869 took no count of nationality, but according to Ficker in his *Die Völkerstämme der Oesterreichisch-Ungarischen Monarchie*, there are 20 of German race for 32 of Slavonic. By far the greater part of the population (4,940,898) belongs to the Roman Catholic Church; while only 3438 are members of the Greek Church, 106,115 Protestants, and 89,933 Jews. The country constitutes an archbishopric, and is divided into three bishoprics. In 1870 there were 140 ecclesiastical foundations, with endowments amounting to £65,726. At the head of the educational establishments is the University of Prague, with four faculties, and attended in 1871 by 1516 students. There are upwards of 4000 ordinary schools; rather more than the half of which Czech is spoken, 26 gymnasiums, 4 theological seminaries, and several institutions for special departments of the arts and sciences.

Bohemia derives its name from the Boii, a Celtic race expelled from the country by the Marcomanni, who, after establishing a considerable kingdom under Marbod and being converted to Christianity, were in their turn supplanted by the Slavonic race, which is still predominant. The new comers were in danger of expulsion or conquest by the Avars, but were defended and established, according to their own possibly mythical account, by the heroic Samo; and somewhat later, as the story goes, his place was filled by the good knight Krok, whose daughter Libussa, marrying Premysl, became the founder of a regular dynasty. Bohemia was for a time absorbed in the great Carolingian monarchy, but soon reasserted its independence. In the course of the 9th century Christianity was introduced. Under Boleslas I. the bounds of Bohemia were extended and its unity secured; but after a vigorous defence he had to recognize the overlordship of Otto I. of Germany. Under his grandchildren his kingdom fell to pieces; a Polish conquest followed, and the restoration of the native dynasty was only effected by the help of Henry II. of Germany. In 1086 Wratislaw II. received the title of king from the emperor for himself; and Premysl Ottocar I. (1197–1230) became the founder of a hereditary series of kings. He was a bold defender of his independence, and at the same time gave great encouragement to German immigration. By the introduction of the right of primogeniture in the succession to the throne, he put an end to the disputes and contests which so often followed the death of a king. In 1241 his son and successor was the successful defender of Europe against a Mongolian invasion; but he was eclipsed by Ottocar II. (1253–1278), who added greatly by conquest to the extent of his dominions, and made himself a formidable rival to the emperor himself. The Premysl dynasty was at last extinguished in 1306; and after a few years of uncertainty and dissatisfaction the Bohemian crown was bestowed on John of Luxembourg (son of the Emperor Henry VII.), who thus became the founder of a dynasty which lasted till 1437. This warlike and prosperous monarch was succeeded by his son Charles I., who obtained the imperial dignity as Charles IV., and left Bohemia in a flourishing and influential position at his death in 1378. Under his successors, who fell far below the character of their ancestor, the country was thrown into confusion by the Hussite reformation, which resulted in a protracted war (1419–1434). The success of the reforming party led to an elective monarchy, and after various vicissitudes, George of Podiebrad mounted the throne in 1458; and in spite of Papal bull and Hungarian arms maintained his position till his death in 1471. His successor, the Polish prince Ladislas, ultimately obtained also the crown of Hungary; but under him and his son Louis (1517–1526) the nobility made themselves more and

more independent of the king, and the common people were crushed deeper into serfdom. On the death of Louis, in a battle against the Turks at Mohacz, Bohemia passed into the hands of Ferdinand of Austria, who treated the kingdom in the most despotic manner, and in 1547 declared it a hereditary possession. He was followed in succession by his son Maximilian II and his grandson Rudolph II, who left the country as distracted as they found it. The son of Matthias, the next king, was rejected by the Protestant party, which chose in his stead Frederick V. of the Palatinate; but the victory at the White Mountain in 1620 left Bohemia at the mercy of the emperor, who inflicted a terrible vengeance on his enemies, and in 1627 declared the country a purely Catholic and hereditary kingdom of the empire. Owing to this no fewer than 30,000 families are said to have gone into exile and the population of the country was reduced to 800,000. On the death of Charles VI. Charles Albert of Bavaria laid claim to the crown, which continued to be an object of dispute though the Silesian campaigns and the Seven Years' War, but was successfully defended by Maria Theresa and her son Joseph II. The country was greatly benefited in many ways by the government of that monarch; but he destroyed the independence of the royal towns, and treated the whole land as a mere province of the empire. Its religious condition was considerably improved, however, by an edict of toleration published in 1781. Under the succeeding reigns the circumstances of Bohemia underwent but little alteration, and it was hardly affected by the first French Revolution. In 1848, however, a determined "national" movement agitated the country. The demands of the Liberal party gradually increased, and nothing short of a full share in the constitutional government of their country would suffice. The movement was not confined to Bohemia, but spread through the whole Austrian empire, to the article on which (p. 137 of the present volume) the reader is referred. (See Fruher, *Rerum Bohemicarum Antiqui Scriptores*, 1602; Dobner, *Monumenta Historica*, 1764-68; Pelzel, *Geschichte der Böhmen*, 1817; Palacky, *Geschichte von Böhmen*, 1839; Jordan, *Geschichte des böhm. Volkes und Landes*, 1845-47.)

The Bohemians or Czechs speak a Slavonic language, which has been subjected to literary culture from about (if not before) the 9th century. A few fragments of a pre-Christian literature have been preserved in a manuscript discovered by Hanka in 1817 in the church-steeple of Königshof; but the first productions of any extent are due to the activity of the early German Christians, and are composed for the most part in the Latin language. Against this powerful exotic speech the vernacular had a long and dubious struggle, especially in the ecclesiastical domain, and it was still striving against its encroachments when the political circumstances of the nation exposed it to the more dangerous, because more popular and less artificial, rivalry of German. From the court and the capital outward over the nobility and the country there spread a Germanizing energy that at first seemed likely to destroy everything that was distinctively Bohemian; but here and there the national language and customs were fostered and preserved by a few patriotic spirits, among whom the monks of the Slavonic monastery of Sazawa were especially conspicuous. At length the native language obtained the imperial patronage (under Charles IV.) Dalimil wrote his *Rhyming Chronicle of Bohemia* (1314); and translations began to be made from Latin and other languages. Among these were Mandeville's *Travels*; and about the end of the 14th century a complete version of the Scriptures, the manuscript of which is preserved at Nikolburg in Moravia. Thomas Stitny the domestic moralist, Dube the jurist, and Flaska the didactic poet,

deserve to be mentioned as original writers. The next generation saw the attempts at once at religious and at linguistic reform that came to so sad an end in the burning of John Huss and the persecutions that followed. The Bohemian language was, indeed, brought into general use and served the disputants of both sides; but little was consigned to its keeping except the ephemeral productions of ecclesiastical and political strife. A large collection of these works, saved from destruction by the invading Swedes, is still preserved in the library of Stockholm. Of more permanent interest may be mentioned Paul Zidek's *History of the World*, written for George of Podiebrad; the interesting travels of Leo of Rosmital and his companions through various countries of Europe; and those of Kabatnik in Egypt and Asia Minor, and of John of Lobkowitz in Palestine. The 16th century saw a remarkable development of Bohemian prose in various departments of literature. Weleslawin, Paprocky, and Hayek of Libocun wrote popular histories; Wratislas of Mitrovic and Prefat of Wilkanow gave accounts of their travels; and Nicolas Konec, Dobrenaky, and Lomnicky produced didactic works of various kinds. A valuable translation of the Bible was published at Kralitz in Moravia by eight learned Bohemian Brethren at the instigation of John of Zerotin; and various versions of the classics appeared from time to time. A long period of literary decadence followed the battle of the White Mountain in 1620. The best blood of the nation went into exile, and what Bohemian literature was produced appeared for the most part in foreign cities. In 1774 a severe blow was struck at the native language by Maria Theresa's imperial decree which enforced the use of German in the higher and middle schools of the country. Before long, however, the defence of the mother tongue was taken up by Count Kinsky, Hanka of Hankenstein, the historian Pelzel, and the Jesuit Balbin,—by the last mentioned in a *Dissertatio apologetica pro lingua Bohemica*. The language became the object of the scientific investigations of Dobrowsky, and the remains of the early periods were edited by Dobner, Prochaska, and other philologists. A chair of the Bohemian language was founded in the University of Prague, and in 1818 a Bohemian museum was established in connection with a society that devoted itself to the study of national antiquities, and published a valuable journal. Puchmayer (1795-1820) gave an impulse to national poetry, and has been succeeded by Langer, Roko, Wocel, Schneider, Czelakowsky, and Kollar, and a great number of other writers. In the department of science Presl, Sedek, Amerling, Smetana, Petzina, Sloboda, and Opis have attained distinction. Grammars of the Czech language have been produced by Burian, Hanka, Maly, Sembers, and Tomicek; Sumawsky published a great German-Bohemian dictionary; Spatny, a Bohemian-German and German-Bohemian technological dictionary; and Jungmann a large Bohemian-German lexicon. The names of even the prominent writers in philosophy, theology, and politics are too numerous to be mentioned. (See Schafarik's *Slavisch Alterthümer*, 1842, and *Geschichte der Slav. Sprache*, 1826; Jungmann's *Geschichte der Böhm. Sprach- und Literatur*, 1825.)

BOHEMOND, MARC, one of the leaders of the Crusades, born about 1056, was the eldest son of Robert Guiscard, a Norman, who had obtained by conquest the dukedom of Apulia and Calabria. From 1081 to 1085 he served under his father in a war against the Byzantine emperor Alexander Comnenus, whom he twice defeated, though he had to return to Italy without reaping any substantial fruits of his success. In 1085 his father died, leaving Apulia and Calabria to a younger son, while Bohemond obtained only the small principality of Tarentum. A war between the

brothers followed, from which, however, Bohemond was speedily diverted by the Crusades, which opened up a wider field for his ambition. Accompanied by his cousin Tancred, he led an army of 10,000 cavalry and 20,000 infantry, with which he would have besieged Constantinople had he been able to persuade Godfrey of Bouillon to join him. He took a leading part in the battle of Dorylæum (1097), and the other engagements of the campaign in Asia Minor. A year later he besieged and captured Antioch, of which he assumed the principality. In 1101 he was defeated and taken prisoner by the Turks. Released, after a captivity of two years, on the payment of a very heavy ransom, he returned to Europe to collect troops. In 1106 he visited France, and married Constance, a daughter of Philip I. With an army levied in France, in right of his marriage, he renewed war with Alexius, but being unsuccessful in the siege of Durazzo he was obliged to conclude a peace in 1108. He died at Canosa in Apulia in 1111. (See Gibbon's *Decline and Fall*, c. lviii., lx.; and Michaud's *Histoire de Croisades*.)

BOIARDO, COUNT MATTEO MARIA, of a noble and illustrious house established at Ferrara, but originally from Reggio, was born at Scandiano, one of the seignorial estates of his family, near Reggio di Modena, about the year 1434, according to Tiraboschi, or 1420 according to Mazzuchelli. At an early age he entered the University of Ferrara, where he acquired a good knowledge of Greek and Latin, and even of the Oriental languages, and was in due time admitted doctor in philosophy and in law. At the court of Ferrara, where he enjoyed the favour of Duke Borsò d'Este and his successor Hercules, he was entrusted with several honourable employments, and in particular was named governor of Reggio, an appointment which he held in the year 1478. Three years afterwards he was elected captain of Modena, and reappointed governor of the town and citadel of Reggio, where he died in the year 1494, though in what month is uncertain. Almost all his works, and especially his great poem of the *Orlando Innamorato*, were composed for the amusement of Duke Hercules and his court, though not written within its precincts. His practice, it is said, was to retire to Scandiano or some other of his estates, and there to devote himself to composition; and Castelvetro, Vallisneri, Mazzuchelli, and Tiraboschi, all unite in stating that he took care to insert in the descriptions of his poem those of the agreeable environs of his chateau, and that the greater part of the names of his heroes, as Mandricardo, Gradaseo, Sacripant, Agramant, and others, were merely the names of some of his peasants, which, from their uncouthness, appeared to him proper to be given to Saracen warriors. Be this as it may, the *Orlando Innamorato* deserves to be considered as one of the most important poems in Italian literature, since it forms the first example of the romantic epic worthy to serve as a model, and, as such, undoubtedly produced the *Orlando Furioso*. Gravina and Mazzuchelli have said, and succeeding writers have repeated on their authority, that Boiardo proposed to himself as his model the *Iliad* of Homer; that Paris is besieged like the city of Troy; that Angelica holds the place of Helen; and that, in short, the one poem is a sort of reflex image of the other. In point of fact, however, the subject-matter of the poem is derived from the *Fabulous Chronicle* of the pseudo-Turpin; though, with the exception of the names of Charlemagne, Roland, Oliver, and some other principal warriors, who necessarily figure as important characters in the various scenes, there is little resemblance between the detailed plot of the one and that of the other. The poem, which Boiardo did not live to finish, was printed at Scandiano the year after his death, under the superintendance of his son Count Camille. The title of the book is without date: but a Latin letter from Antonia Caraffa di

Reggio, prefixed to the poem, is dated the kalends of June 1495. A second edition, also without date, but which must have been printed before the year 1500, appeared at Venice; and the poem was twice reprinted there during the first twenty years of the 16th century. These editions are the more curious and valuable, that they contain nothing but the text of the author, which is comprised in three books, divided into cantos, the third book being incomplete. But Niccolò degli Agostini, an indifferent poet, had the courage to continue the work commenced by Boiardo, adding to it three books, which were printed at Venice in 1526-1531, in 4to; and since that time no edition of the *Orlando* has been printed without the continuation of Agostini, wretched as it unquestionably is. Boiardo's poem suffers from the incurable defect of a laboured and heavy style. His story is skillfully constructed, the characters are well drawn and sustained throughout; many of the incidents show a power and fertility of imagination not inferior to that of Ariosto, but the perfect workmanship indispensable for a great work of art is wanting. The poem in its original shape was not popular, and has been completely superseded by the *Rifacimento* of Francesco Berni. See BERNI.

The other works of Boiardo are—1. *Il Timone*, a comedy, Scandiano, 1500, 4to; 2. *Sonnetti e Canzoni*, Reggio, 1499, 4to; 3. *Carmen Bucolicum*, Reggio, 1500, 4to; 4. *Cinque Capitoli in terza rima*, Venice, 1523 or 1533; 5. *Apulejo dell' Asino d'Oro*, Venice, 1516, 1518; 6. *Asino d'Oro de Luciano tradotto in volgare*, Venice, 1523, 8vo; 7. *Erodoto Alicarnasso istorico, tradotto di Greco in Lingua Italiana*, Venice, 1533 and 1538, 8vo; 8. *Rerum Italicarum Scriptores*. (See Panizzi's *Boiardo*, 1830-31.)

BOIELDIEU, FRANÇOIS-ADRIEN, is the chief representative of the national school of comic opera in France, a branch of art in which everything that is most lovable and at the same time most national in the French character has found its full expression. He was born at Rouen in 1775, and received his first musical education from M. Broche, the organist of the cathedral of that city. It is said that, when quite a youth, in order to escape the punishment of a severe master for a slight offence, he went off to Paris on foot, but was discovered and brought back by his parents. He began composing songs and chamber music at a very early age,—his first opera, *La Famille Suisse*, being produced on the stage of Rouen in 1795, where it met with an enthusiastic reception. Not satisfied with his local success he turned his eyes to that loadstar of youthful ambition, Paris. He went to the capital in 1795, full of hope and expectation. The score of his opera was submitted to the leading musicians of the day, such as Cherubini, Méhul, and others, but met with little approbation. Altogether the time was not favourable for the comic muse. The heroic passions roused by the revolutionary events of the preceding years required commensurate efforts of musical art; the grand opera was the order of the day. Boieldieu had to fall back on his talent as a pianoforte-player for a livelihood, and to wait for a chance of higher success in the meantime. This success came at last from a source whence it was little expected, and, perhaps, less desired. Garat, a fashionable singer of the period, admired Boieldieu's touch on the piano, and made him his accompanist. He also sung in the drawing-rooms of the Directoire the charming songs and ballads with which the young composer supplied him but too willingly. In this manner Boieldieu's reputation gradually extended to wider circles. In 1797 his above-mentioned opera appeared for the first time on a Paris stage, and was well received. Several others followed in rapid succession, of which only the last, *Le Calife de Bagdad* (1799), has escaped oblivion. It tends to show Boieldieu's true artistic vocation, that, after the enormous success of

this work, he felt the want of a thorough musical training, and voluntarily descended from the position of a successful *maestro* to that of a humble pupil. He took lessons from Cherubini, and the influence of that great master is distinctly discernible in the higher artistic finish of Boieldieu's later compositions. In 1802 Boieldieu, for the second time in his life, took to sudden flight, on this occasion in order to escape the domestic troubles caused by his marriage with a celebrated ballet-dancer of the Paris Opera. The frightened husband went to Russia, where he was received with open arms by the Emperor Alexander. During his prolonged stay at St Petersburg he composed a number of operas which it is unnecessary to name. He also set to music the choruses of Racine's *Athalie*, one of his few attempts at the tragic style of dramatic writing. In 1811 he returned to his own country, where the following year witnessed the production of one of his finest works, *Jean de Paris*. The charming coquetry of the queen of Navarre, the chivalrous *verse* of the king, the officious pedantry of the seneschal, and the amorous tenderness of the page—all this rendered in the finest touches that music, and only French music, is capable of, will not soon be forgotten. We pass over a number of other operas of lesser value, partly written in collaboration with other composers, and turn at once to the second and greatest masterpiece of Boieldieu's genius, his *Dame Blanche* (1825). The libretto, written by Scribe, was partly suggested by Walter Scott's *Monastery*, and several original Scotch tunes cleverly introduced by the composer add not a little to the melodious charm and local colour of the work. *La Dame Blanche* marks the highest development of the French school of comic opera. Grétry stood at the head of this school; Cherubini with his *Deus Journées* followed in his wake; Boieldieu, greater than both (in this particular branch of art), reached a perfection which was to some extent sustained by the works of Auber. Boieldieu's pupil, Adam, has in his *Derniers Souvenirs d'un Musicien* left a charming sketch of the genesis of Boieldieu's masterpiece. The chief characteristics of his style are an easy flow of graceful melodies, a refined though occasionally somewhat meagre instrumentation, admirable phrasing, and a most distinct enunciation of the words. The outer events of Boieldieu's career may be summed up in few words. For a long time he occupied the position of professor of composition and pianoforte at the Conservatoire; in 1817 he was made a member of the Institute. The *Dame Blanche* was his last opera but one. Soon after its production he was seized with a violent attack of pulmonary disease. To stop the rapid progress of the illness he travelled in Italy and the South of France, but fell a victim to it on October 8, 1834.

BOII, a Celtic people, who at an early date crossed the Alps and established themselves between the Po and the Apennines to the south of the Insubres and Cenomani. On the defeat of their neighbours the Senones by the Romans they joined the Etruscans against the conquerors, and were involved in the disastrous results of the battle at the Vadimonian Lake in 283 B.C. Equally unsuccessful in the following year, they formed a treaty of peace with the Romans, which they kept for a considerable time, till the encroachments of their conquerors led them to engage in the Great Gallic war of 225 B.C. From that period they continued to indulge their hostility on all occasions, and on the outbreak of the Punic wars gave valuable aid to the Carthaginians from time to time. At length their strength was broken by Scipio Nasica in 191 B.C.; a large proportion of their territory was appropriated and secured by the colonies of Bononia, Parma, and Mutina; and before long the whole race seems to have been constrained to recross the Alps. They betook themselves to that

district of country which is still called in consequence Bohemia; but before many centuries they were expelled by other hostile tribes and their separate existence as a people was lost.

BOILEAU-DESPREAU, NICOLAS, was born at Paris on the 1st November 1636. Crône, not far from the capital, has been frequently stated to be his birthplace, but the matter seems to be pretty nearly settled by the researches of M. Labat (*Recherches historiques sur l'Hôtel de la Préfecture de Police*), who has discovered the very house in the Rue de Jérusalem where the poet was born. He was educated at the College of Beauvais, and was at first destined for the legal profession. From this, however, after a short trial, he recoiled in disgust, complaining bitterly of the amount of chicanery which passed under the name of law and justice. To escape such a course of life he began to study for the church, and actually received a priory of a small annual value, but his wishes soon turned in another direction. He gave up his clerical profession, and, his father having left him a small provision sufficient for his wants, thenceforward devoted himself to letters. Such of his early poems as have been preserved hardly contain the promise of what he ultimately became. The first piece in which his peculiar powers were displayed was a satirical poem, *Adieu of a Poet to the City of Paris*, published in 1660. This was quickly followed by eight others, and the number was at a later period increased to twelve. A twofold interest attaches to the satires. In the first place the author skillfully parodies and attacks writers who at the time were placed in the very first rank, such as Chapelain, Cotin, Quinault, and Scudéri; he openly raised the standard of revolt against the older poets. But in the second place he showed, both by precept and practice, what were the poetical capabilities of the French language. Prose, in the hands of such writers as Descartes and Pascal, had proved itself a flexible and powerful instrument of expression, with a distinct mechanism and form. But except with Malherbe, there had been no attempt to fashion French versification according to rule or method. In Boileau for the first time appeared terseness and vigour of expression, with perfect regularity of verse structure. His fame was quickly established; he received a pension, and was made historiographer along with his friend Racine. In 1664 he composed his prose *Dialogue des héros de roman*, which is a refined satire on the elaborate romances of the time. It may be said to have once for all abolished them. From 1669 onwards appeared the *Epistles*, graver in tone than the satires, maturer in thought, more exquisite and polished in style. In 1674 his two master-pieces, *L'Art Poétique* and *Le Lutrin*, were published. The first, in imitation of the *Ars Poetica* of Horace, lays down the code for all future French verse, and may be said to fill in French literature a parallel place to that held by its prototype in Latin. On our own literature the maxims of Boileau, through the translation revised by Dryden, and through the magnificent imitation of them in Pope's *Art of Criticism*, have exercised no slight influence. Boileau does not merely lay down rules for the language of poetry, but analyses carefully the various kinds of verse composition, and enunciates the principles peculiar to each. Of the four books of the *Art Poétique*, the first and last consist of general precepts, inculcating mainly the great rule of *bon sens*; the second treats of the pastoral, the elegy, the ode, the epigram, and satire; and the third of tragic and epic poetry. Though the rules laid down are of value, their tendency is rather to hamper and render too mechanical the efforts of poetry. Boileau himself, though a great critic in verse, cannot be considered a great poet. The *Lutrin*, a mock heroic poem, of which four cantos appeared in 1674

is by French critics considered the best of Boileau's works. It has furnished the model for the *Rape of the Lock*, but the English poem is superior in richness of imagination and subtlety of invention. The fifth and sixth cantos, afterwards added by Boileau, rather detract from the beauty of the poem; the last canto in particular is quite unworthy of his genius. In the same year which saw the *Art Poétique* and the *Lutris* was published his translation of Longinus *On the Sublime*, to which were afterwards added certain critical reflections. His later publications were chiefly occasional poems, in which his better powers did not shine. He died 13th March 1711. Boileau was extremely delicate in youth, and his constitution seems never to have been very strong. He was a man of warm and kindly feelings, honest, outspoken, and benevolent. Many anecdotes are told of his frankness of speech at court, and of his generous actions. He holds a well-defined place in French literature, as the first who reduced its versification to rule and who taught the value of workmanship for its own sake. His influence on English literature, through Pope and his contemporaries, was not less strong, though less durable. Editions of Boileau's works are very numerous. Perhaps the best is that published by Garnier in 1860, *Œuvres complètes*, with copious notes, an essay by Sainte-Beuve, and *Bolavina*.

**BOILER.** See **STEAM ENGINE**.

**BOIS-LE-DUC**, 's **HERTOGENBOSCH**, or 's **BOSCH**, a city of Holland, capital of the province of North Brabant, 28 miles S.S.E. of Utrecht. It stands at the confluence of the Dommel and the Aa, and is strongly fortified, being defended by a citadel and two forts. The city is handsome and well built, and is intersected by several canals. It contains seven churches, among which is that of St John, founded in the beginning of the 14th century, and one of the finest ecclesiastical edifices in Holland. It has also a handsome town-hall, surmounted by a tower containing a fine set of chimes, a court-house, Government buildings (formerly a Jesuit monastery), an episcopal palace, an orphan asylum, a grammar school (once attended by Erasmus), a prison, two hospitals, an arsenal, and barracks. The trade of Bois-le-Duc is very considerable; it has several distilleries, breweries, and glass-works, and manufactures linen, needles, outlery, &c. It is the seat of a vicar-general, and has tribunals of primary instance and commerce. Originally a hunting-lodge of the Brabant dukes, 's Herlogenbosch, or "Duke's Wood," gradually increased, and in 1184 was raised to the rank of a town and surrounded with walls. In 1453 it was greatly enlarged. Successive attempts made by the Netherlands in 1585, 1594, 1601, and 1603 to get possession of the town were futile; but at length, in 1629, it was captured after a five months' siege. In 1794 it was taken by the French, and in 1814 by the Prussians. Population in 1869, 24,395.

**BOISSARD, JEAN JACQUES**, a classical antiquary and Latin poet, was born at Besançon in 1528. He studied at Louvain; but, disgusted by the severity of his master, he secretly left that seminary, and after traversing a great part of Germany reached Italy, where he remained several years, and was often reduced to great straits. His residence in Italy developed in his mind a taste for antiquities, and he soon formed a collection of the most curious monuments of Rome and its vicinity. He then visited the islands of the Archipelago, with the intention of travelling through Greece, but a severe illness obliged him to return to Rome. Here he resumed his favourite pursuits with great ardour, and having completed his collection, returned to his native country; but not being permitted to profess publicly the Protestant religion, which he had embraced some time before, he withdrew to Metz, where he died, October 30, 1602. His works are—

1. *Poemata, Epigrammatum libri tres, Elegia libri tres, Epistolarum libri tres*, Basel, 1574; 2. *Emblemata*, Metz, 1584; 3. *Icones Florum Illustrium*, 1597, sqq.; 4. *Vitis et Icones Bullarum Turcicarum, &c.*, Frankfurt, 1598; 5. *Theatrum Vitis Humanae*, Metz, 1596; 6. *Romanae Urbis Topographia et Antiquitatum, quibus succincta et breviter describuntur omnia quae tum publicae tum privatae videntur admiratione digna, partes VI.*, Frankfurt, 1597-1602, folio, six volumes in three, with plates, and now very rare; 7. *Icones et Vitis Florum Illustrium*, Frankfurt, 1592 to 1599; 8. *Parnassus Biceps*, Frankfurt, 1601; 9. *De Divinatione et Magia Praestigis*, Oppenheim and Hanau, rare and curious; 10. *Habitus Variarum Gentium*, Metz, 1581, ornamented with seventy illuminated figures.

**BOISSONADE, JEAN FRANÇOIS**, French classical scholar, was born at Paris, 12th August 1774. In 1792 he entered the public service during the administration of General Dumouriez. Driven from it in 1795, he was restored by Lucien Bonaparte, during whose time of office he served as secretary to the prefecture of the Upper Marne. He then definitively resigned public employment and devoted himself to the study of Greek, for which he had always a strong inclination. In 1809 he was named professor of Greek at the faculty of letters at Paris, though he did not assume the title till the death of Larcher, who held the chair, in 1812. In 1828 he succeeded Gail in the chair of Greek at the Collège de France. He also held the offices of librarian of the Bibliothèque du Roi, and perpetual secretary of the Academy of Inscriptions. He died 12th September 1857. Boissonade's works consist mainly of editions of several less known classical writers, such as Philostratus, Marinus, Eusebius, Aristonetus. Perhaps his most widely known editions are those of Babrius (1844), and of Tzetzes (1851). The *Anecdota Graeca*, 5 vols. (1829-33), and *Anecdota Nova* (1844) contain many interesting and comparatively unknown writings. Boissonade was a contributor to the *Journal des Débats* and other critical journals, and a selection of his papers has been published by M. Colinclamp, *Critique littéraire sous le premier Empire*, 2 vols., 1863.









